

- | | |
|----------------------------------|------------------------------|
| (D) Montageanleitung | (FR) Notice de montage |
| (NL) Handleiding voor de montage | (CZ) Montážní návod |
| (HU) Szerelési útmutató | (TR) Montaj talimatı |
| (GB) Assembly instructions | (IT) Istruzioni di montaggio |
| (PL) Instrukcja montażu | (SK) Návod na montáž |
| (RO) Instrucțiuni de montaj | (RU) Инструкция по монтажу |

**Service • Assistenza • Dienstverlening • Serwis
Servis • Szerviz • Сервисная служба**

Name • Nom • Nome • Naam •
Nazwa • Jméno • Názov • Név •
Denumire • Isim • Название

Nr. • No. • N° • Номер • С • Sz

Typ • Type • Tip • Tipus • Тип •
Тип

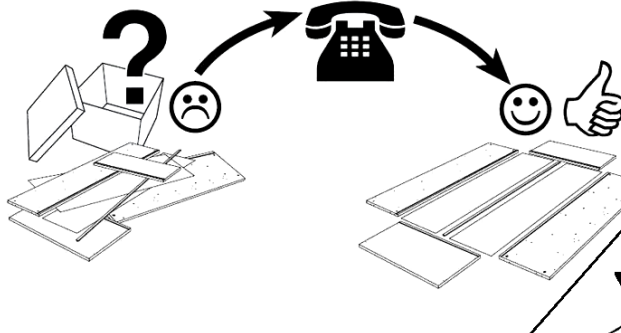
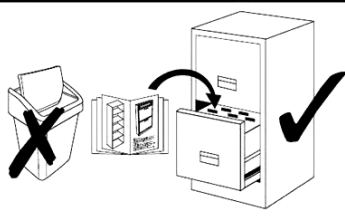
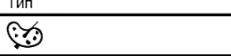

4 ≠ 7

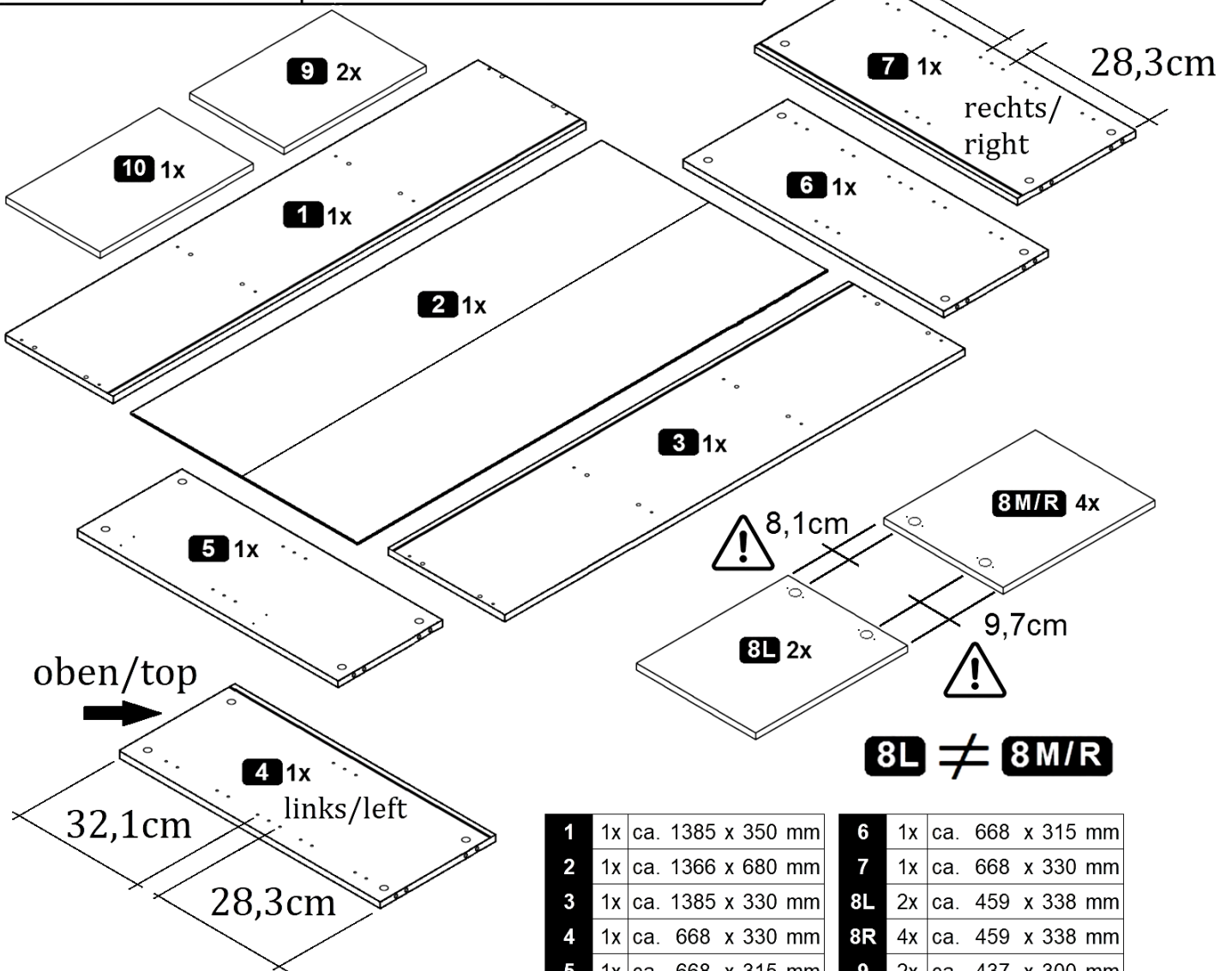

1	1x	ca. 1385 x 350 mm
2	1x	ca. 1366 x 680 mm
3	1x	ca. 1385 x 330 mm
4	1x	ca. 668 x 330 mm
5	1x	ca. 668 x 315 mm

6	1x	ca. 668 x 315 mm
7	1x	ca. 668 x 330 mm
8L	2x	ca. 459 x 338 mm
8R	4x	ca. 459 x 338 mm
9	2x	ca. 437 x 300 mm
10	1x	ca. 450 x 300 mm



A 8,0 x 30 mm 16x	B 16x	C 16x	D 6x	E 3,5 x 9,5 mm 12x	F 6x	G 4,0 x 20 mm 6x
H Ø35 Kr.0 3,5x13 mm 8x	I h=2 12x	J 12x	K 2,7 x 20 mm 8x	L Ø35 Kr.8 3,5x13 mm 4x		

1

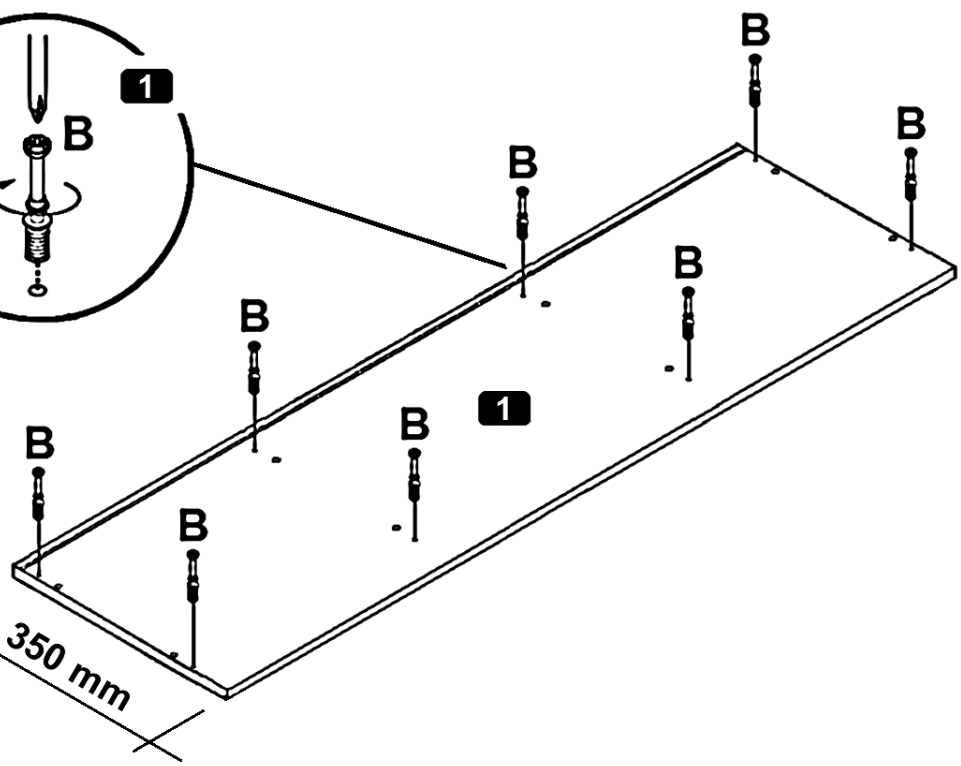
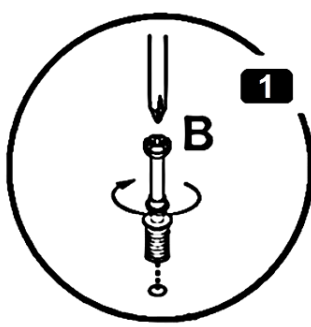
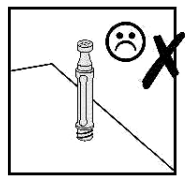
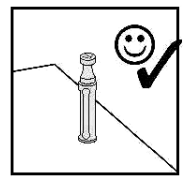
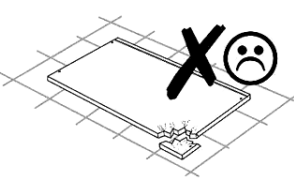
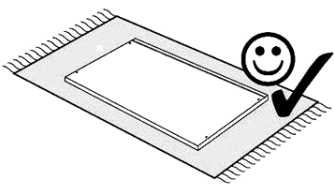
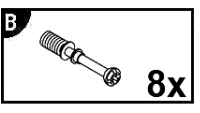

2

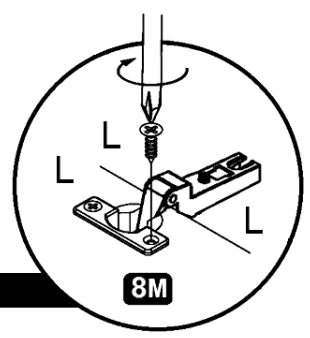
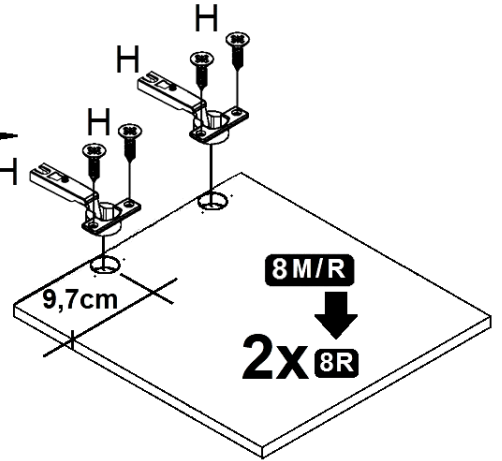
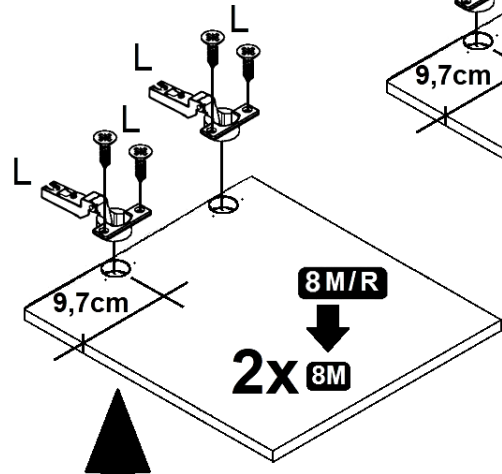
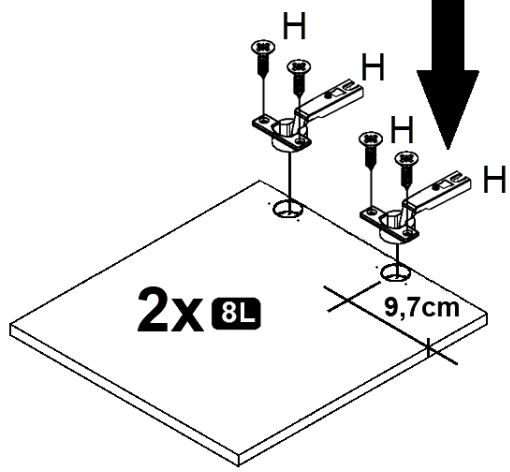
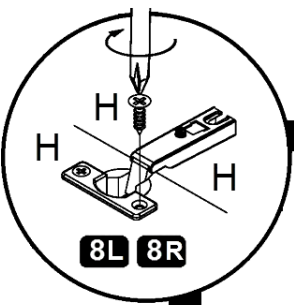
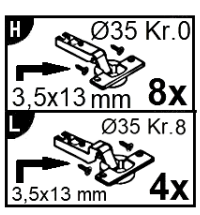

3

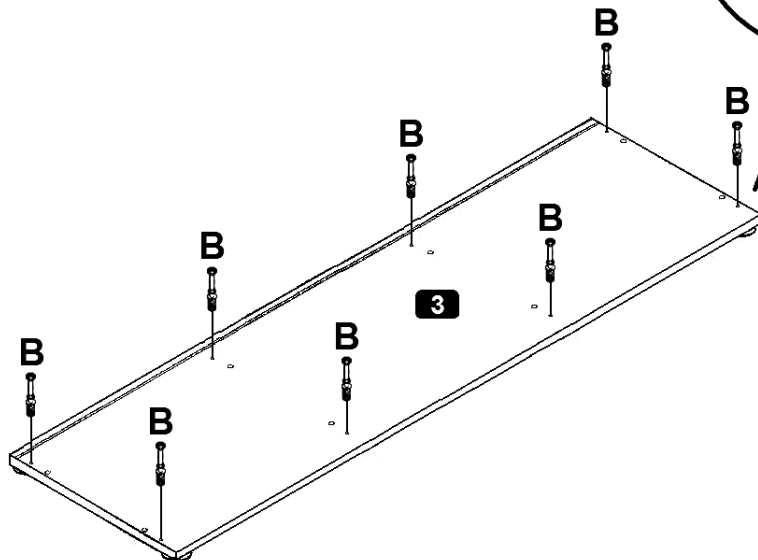
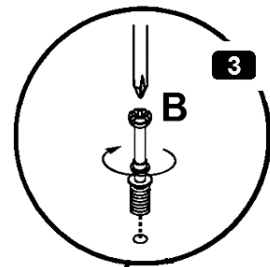
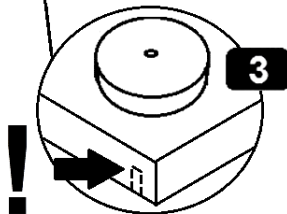
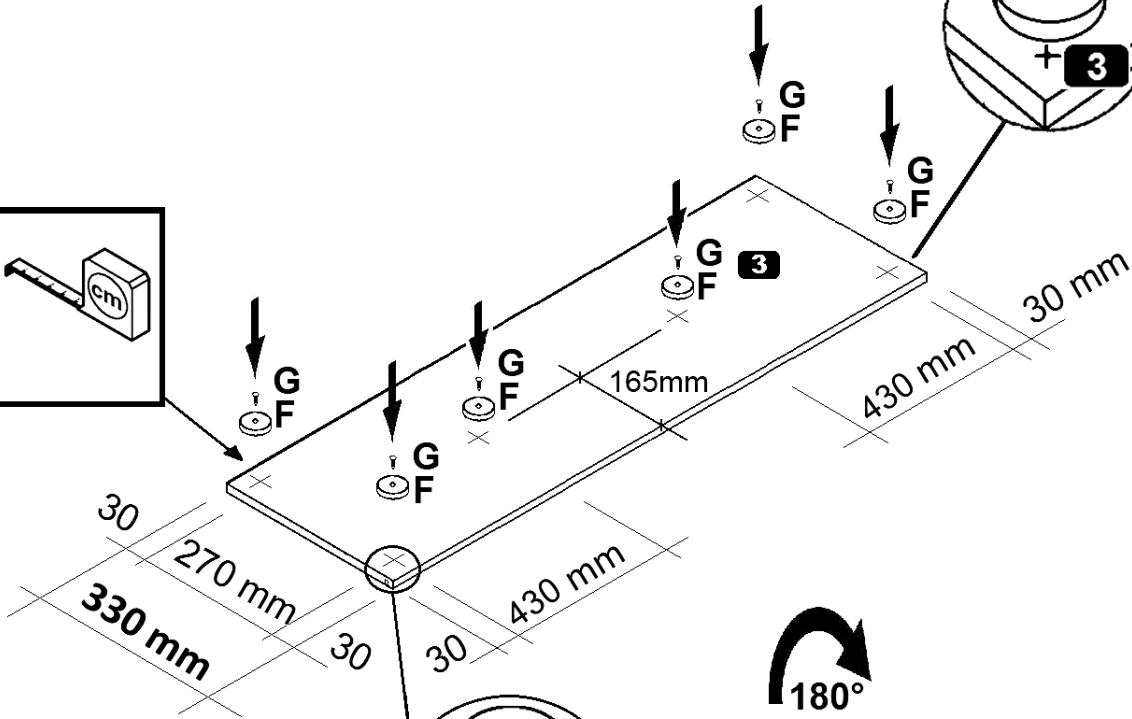
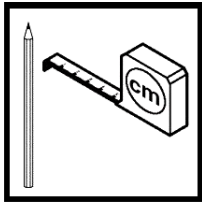
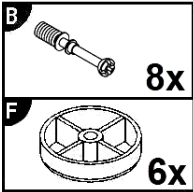
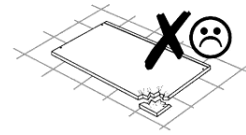
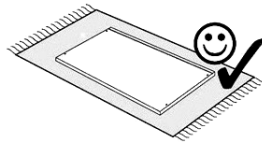
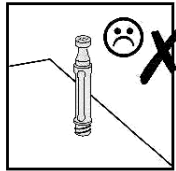
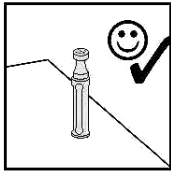

4

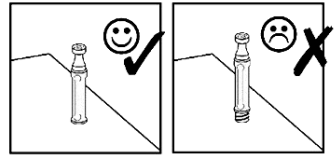

- A** 8,0 x 30 mm **16x**
- C** **16x**
- D** **6x**
- E** 3,5 x 9,5 mm **12x**
- I** h=2 **12x**

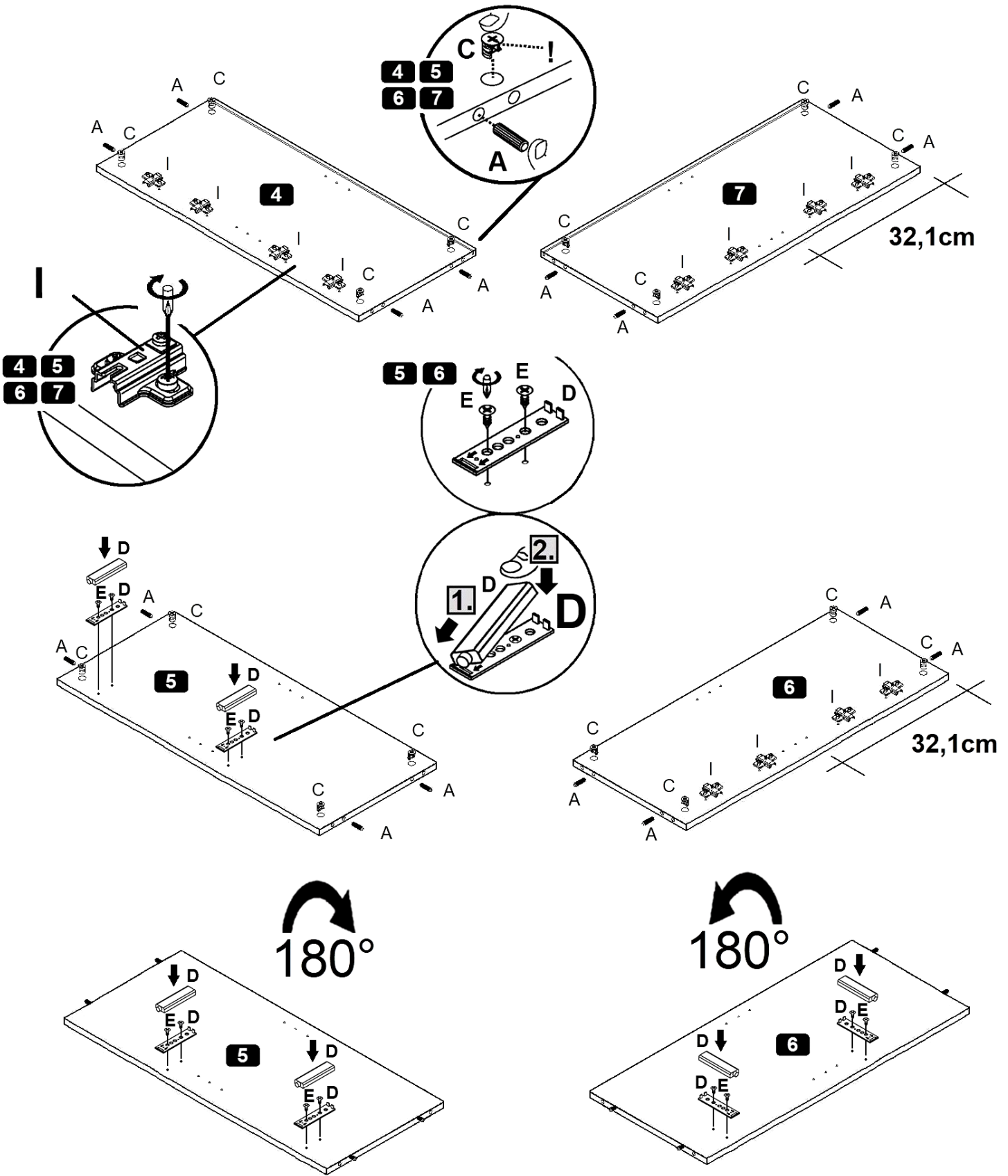

5

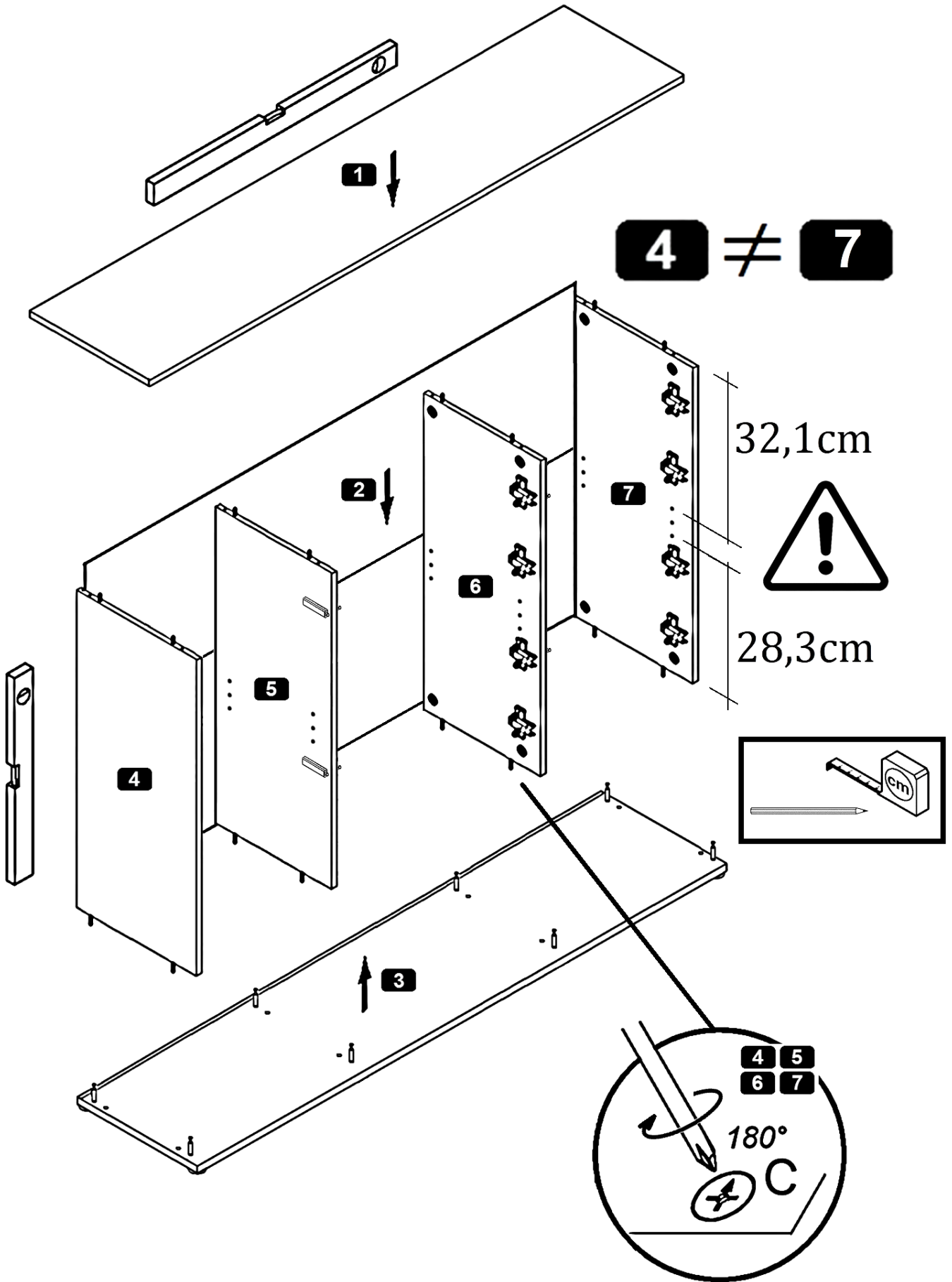

6

K 2,7 x 20 mm
8x

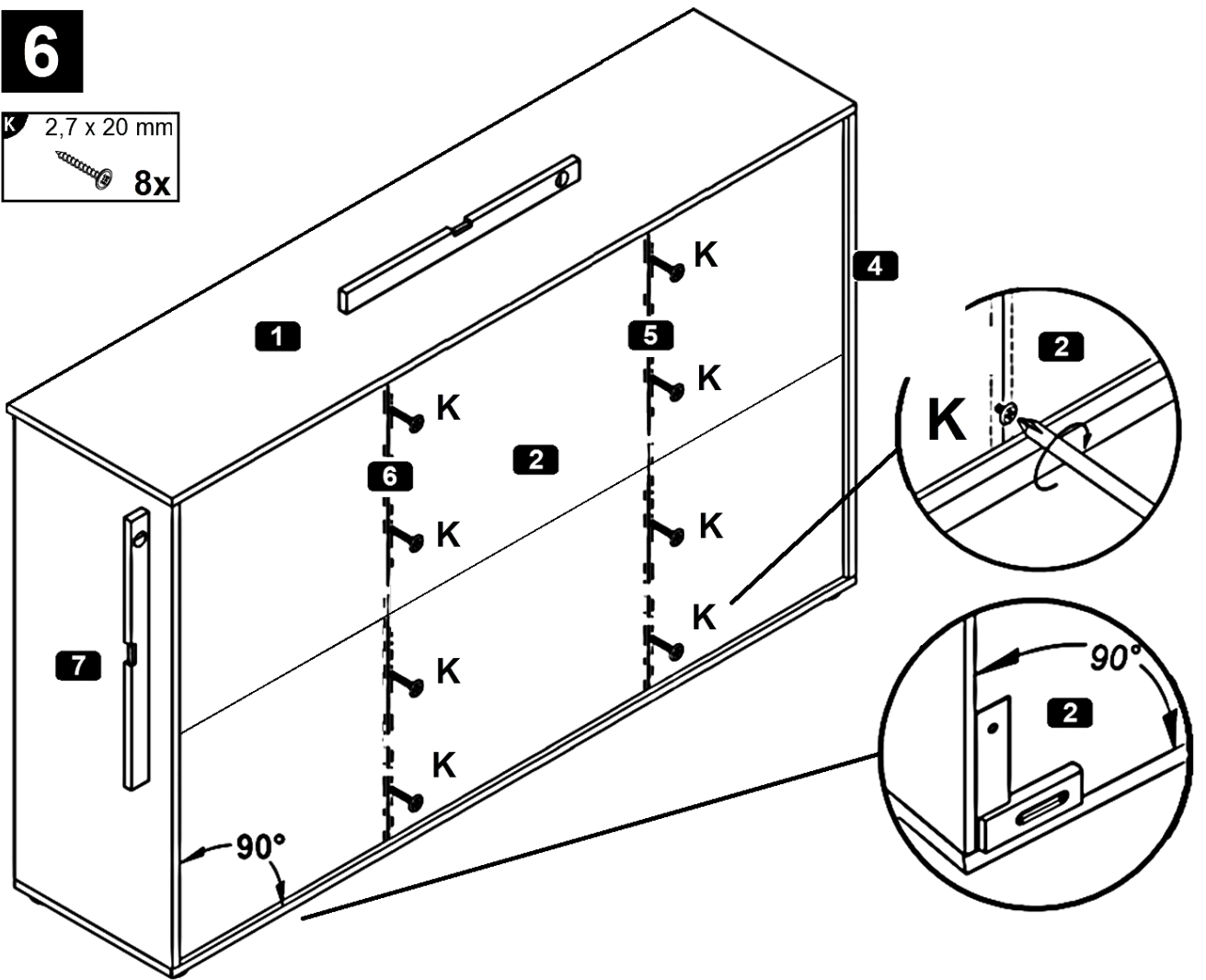

7

J 12x

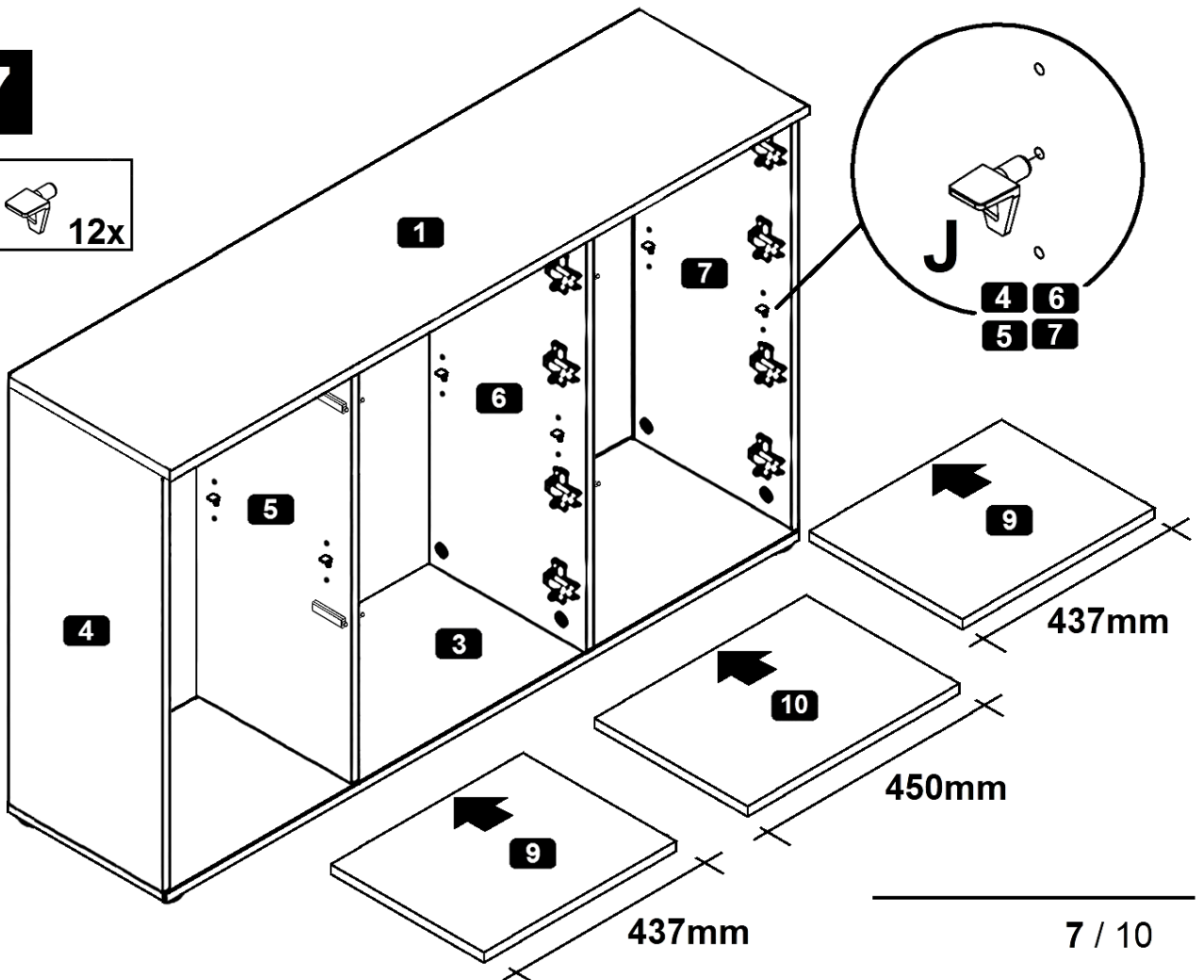

8

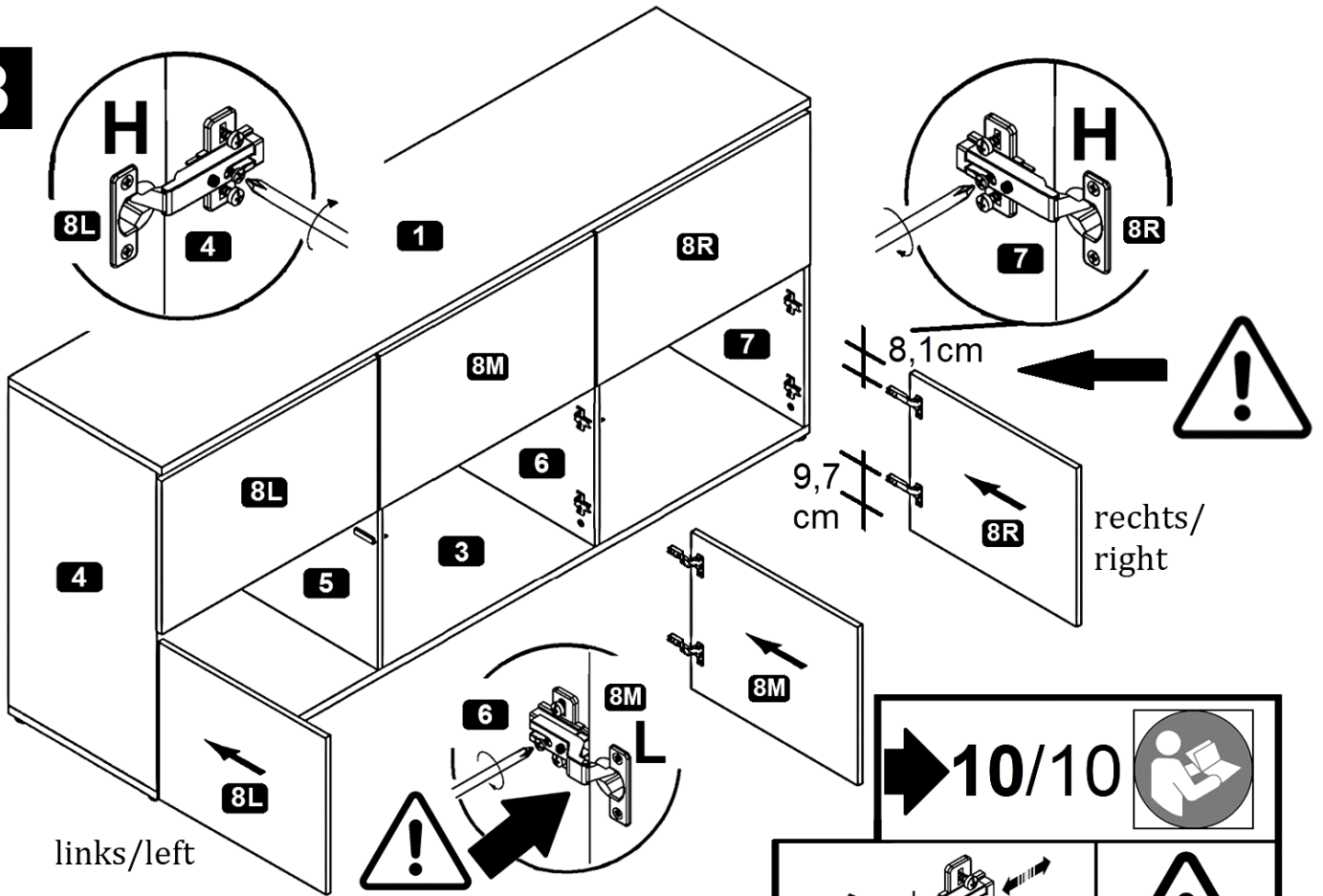

links/left

rechts/
right

➔ 9 / 10

- (D)** Push-To-Open einstellen
- (GB)** Adjusting the Push-To-Open
- (FR)** Régler les Push-To-Open
- (IT)** Sistemare Push-To-Open
- (NL)** Push-To-Open instellen
- (PL)** Nastawić Push-To-Open
- (CZ)** Vyrovnajte Push-To-Open
- (RO)** Nastavenie Push-To-Open
- (HU)** Állítsa be az Push-To-Open
- (SK)** Reglare Push-To-Open
- (TR)** Push-To-Open ayarlanması
- (RU)** Регулировка Push-To-Open

➔ 10/10

- (D)** Türen einstellen (Scharniere justieren)
- (GB)** Adjusting the doors (adjusting the hinges)
- (FR)** Régler les portes (ajuster les charnières)
- (IT)** Sistemare le porte (regolare le cerniere)
- (NL)** Deuren instellen (scharnieren afstellen)
- (PL)** Nastawić drzwi (wyregulować zawiasy)
- (CZ)** Vyrovnajte dvířka (seřid'te závěsy)
- (RO)** Nastavenie dverí (nastavenie závesov)
- (HU)** Állítsa be az ajtókat (állítsa be a zsanérokot)
- (SK)** Reglare uši (ajustare balamale)
- (TR)** Kapıların ayarlanması (menteşelerin seviye ayarı)
- (RU)** Регулировка дверей (регулировка шарнира)

9

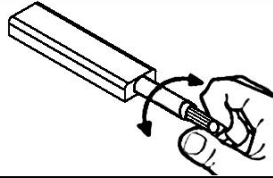

(D) Push-To-Open einstellen

(GB) Adjusting the Push-To-Open

(FR) Régler les Push-To-Open

(IT) Sistemare Push-To-Open

(NL) Push-To-Open instellen

(PL) Nastawić Push-To-Open

(CZ) Vyrovnajte Push-To-Open

(RO) Nastavenie Push-To-Open

(HU) Állítsa be az Push-To-Open

(SK) Reglare Push-To-Open

(TR) Push-To-Open ayarlanması

(RU) Регулировка Push-To-Open

1.

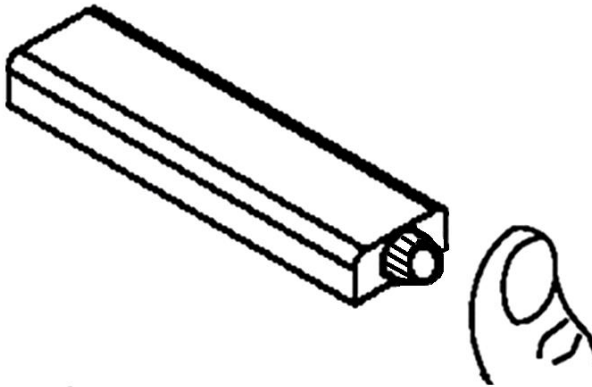

2.

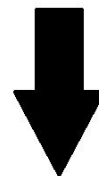
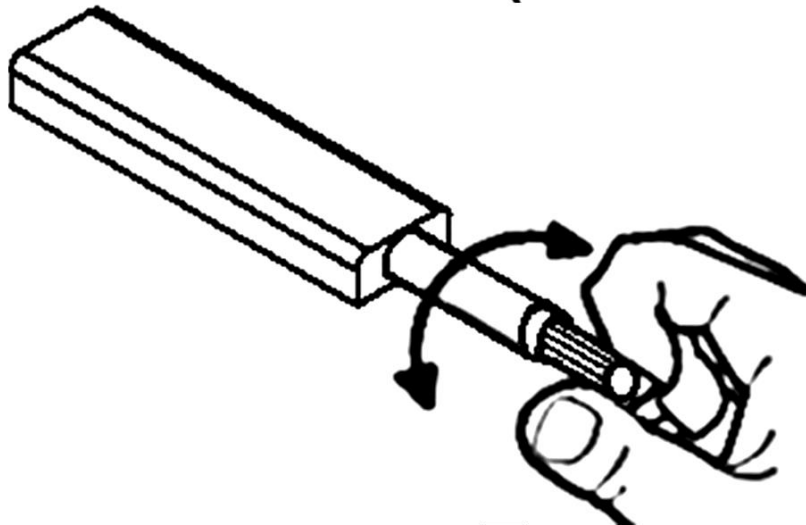

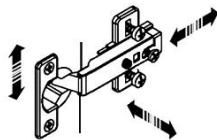

- (D) **Türen einstellen**
(Scharniere justieren)
- (GB) **Adjusting the doors**
(adjusting the hinges)
- (FR) **Régler les portes**
(ajuster les charnières)
- (IT) **Sistemare le porte**
(regolare le cerniere)
- (NL) **Deuren instellen**
(scharnieren afstellen)
- (PL) **Nastawić drzwi**
(wyregulować zawiasy)

- (CZ) **Vyrovnejte dvířka**
(seřid'te závěsy)
- (RO) **Nastavenie dverí**
(nastavenie závesov)
- (HU) **Állítsa be az ajtókat**
(állítsa be a zsanérokot)
- (SK) **Reglare uši**
(ajustare balamale)
- (TR) **Kapıların ayarlanması**
(menteşelerin seviye ayarı)
- (RU) **Регулировка дверей**
(регулировка шарнира)

