

Item number  
48515WG2

item name  
PALAMOS

production week/year  
/2023

factory  
#200

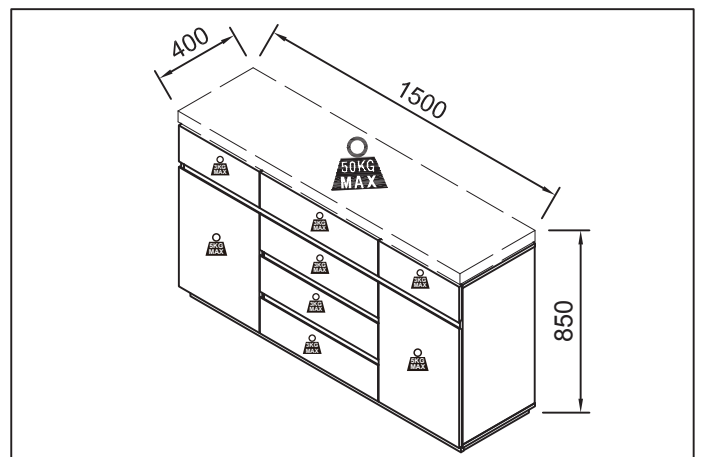
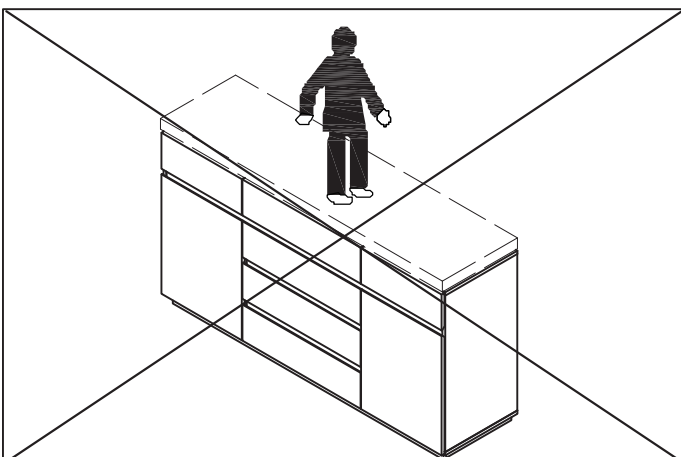
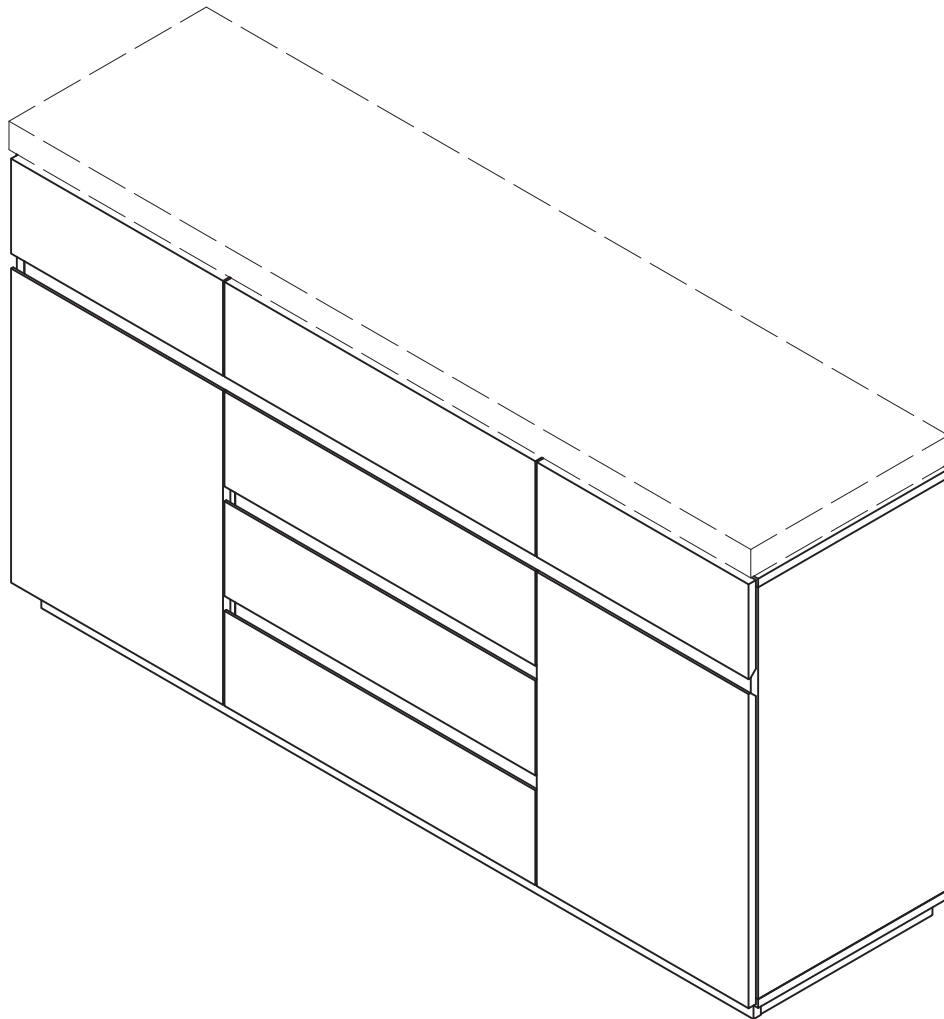

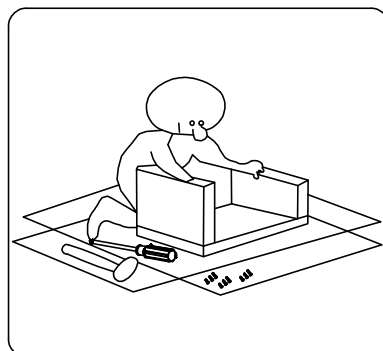
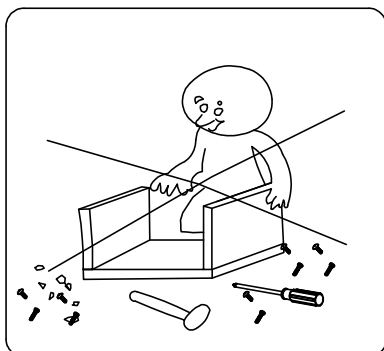
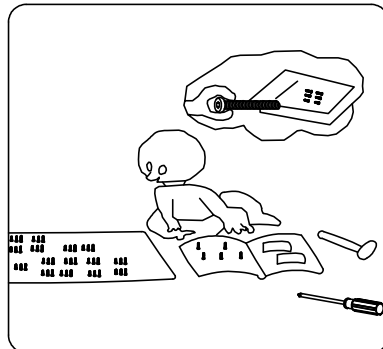
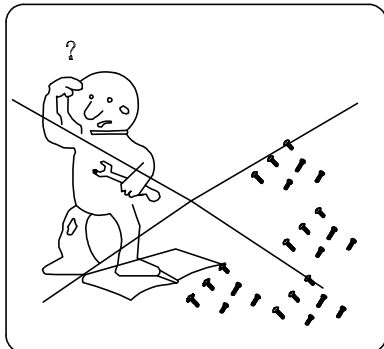
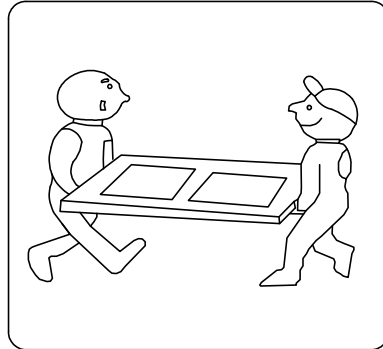
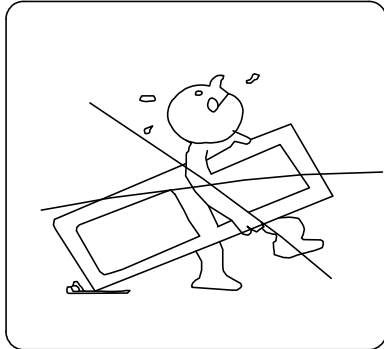
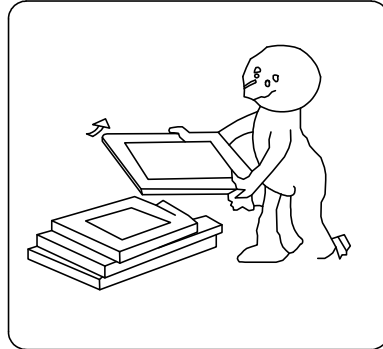
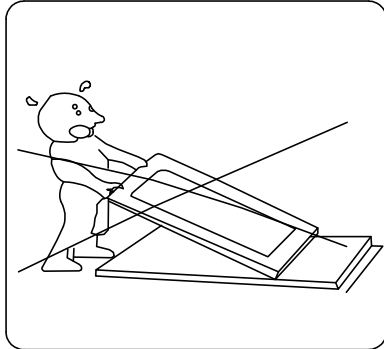
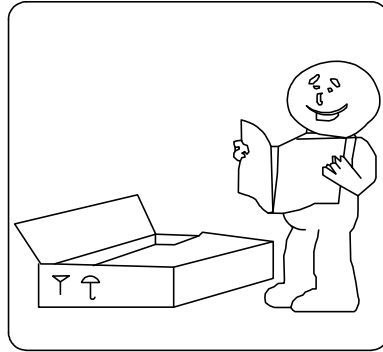
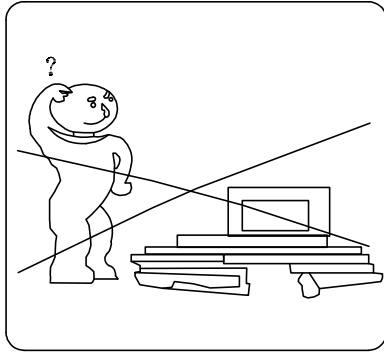

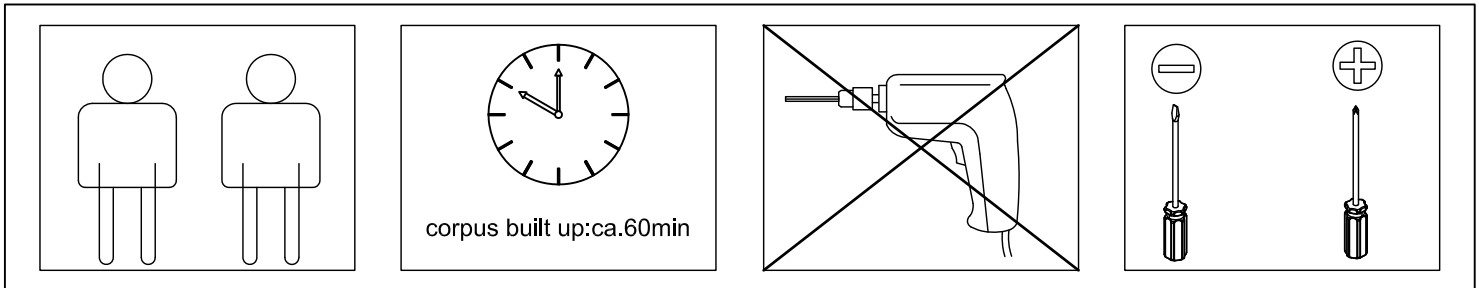
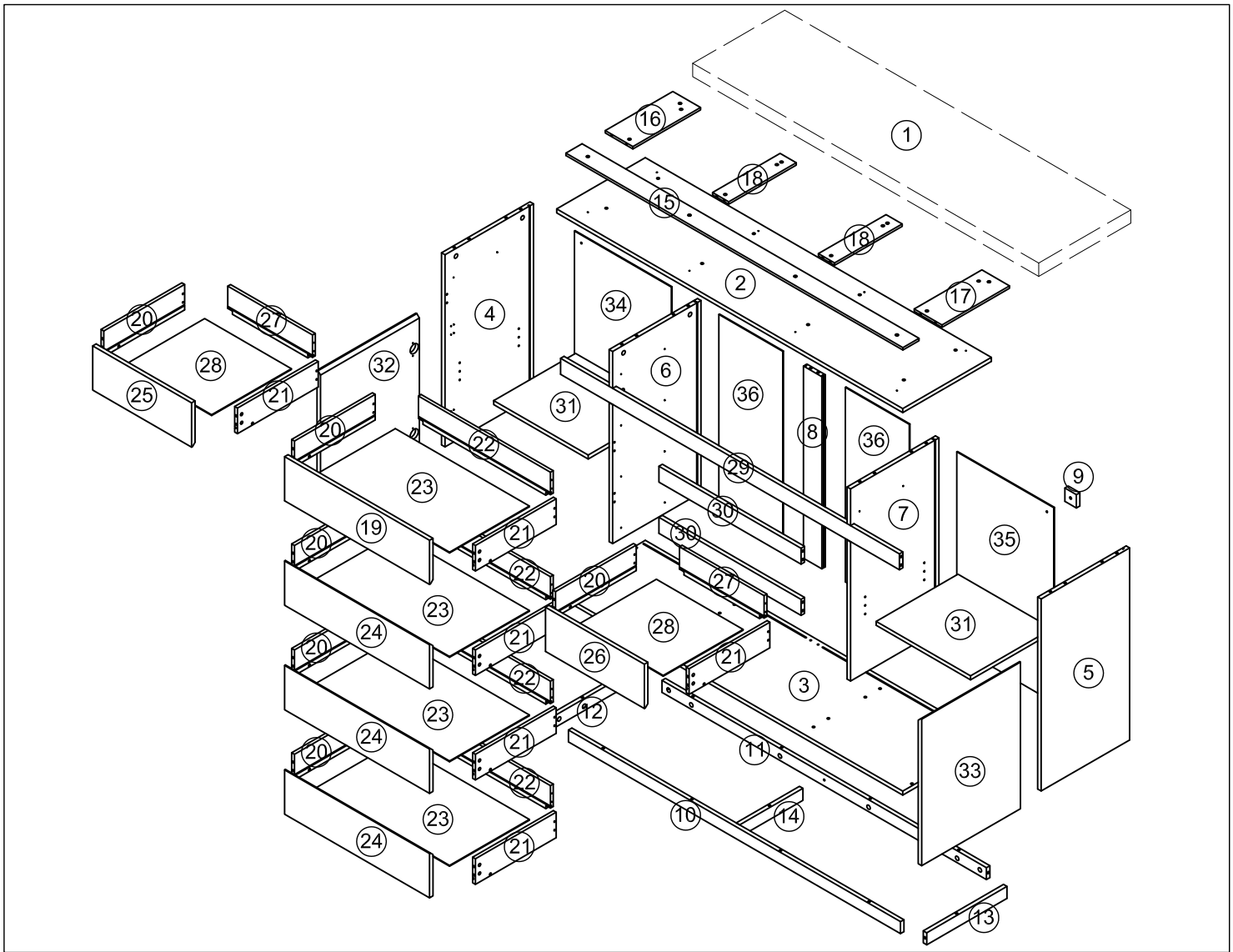

|           |      |                |      |          |      |           |      |           |      |         |      |
|-----------|------|----------------|------|----------|------|-----------|------|-----------|------|---------|------|
| A         | x 16 | B              | x 43 | C        | x 43 | D         | x 16 | E         | x 40 | F       | x 12 |
|           |      |                |      |          |      |           |      |           |      |         |      |
| Ø7.8*30mm |      | M6*36mm        |      | Ø15*12mm |      | 14*14*9mm |      | Ø3.5*12mm |      | M7*50mm |      |
| G         | x 8  | H              | x 8  | I        | x 4  | J         | x 24 | K         | x 1  | L       | x 8  |
|           |      |                |      |          |      |           |      |           |      |         |      |
| M6*38mm   |      | φ13*φ6.5*1.5mm |      | Ø35mm    |      | Ø4*15mm   |      | M4        |      | Ø5*14mm |      |
| M         | x 8  | N              | x 8  | O        | x 24 | P         | x 24 | Q         | x 24 | R       | x 6  |
|           |      |                |      |          |      |           |      |           |      |         |      |
| Ø6*30mm   |      | Ø4*20mm        |      | M6*25mm  |      | Ø10*10mm  |      | Ø4*30mm   |      | 350mm   |      |
| S         | x 6  |                |      |          |      |           |      |           |      |         |      |
|           |      |                |      |          |      |           |      |           |      |         |      |
| 350mm     |      |                |      |          |      |           |      |           |      |         |      |

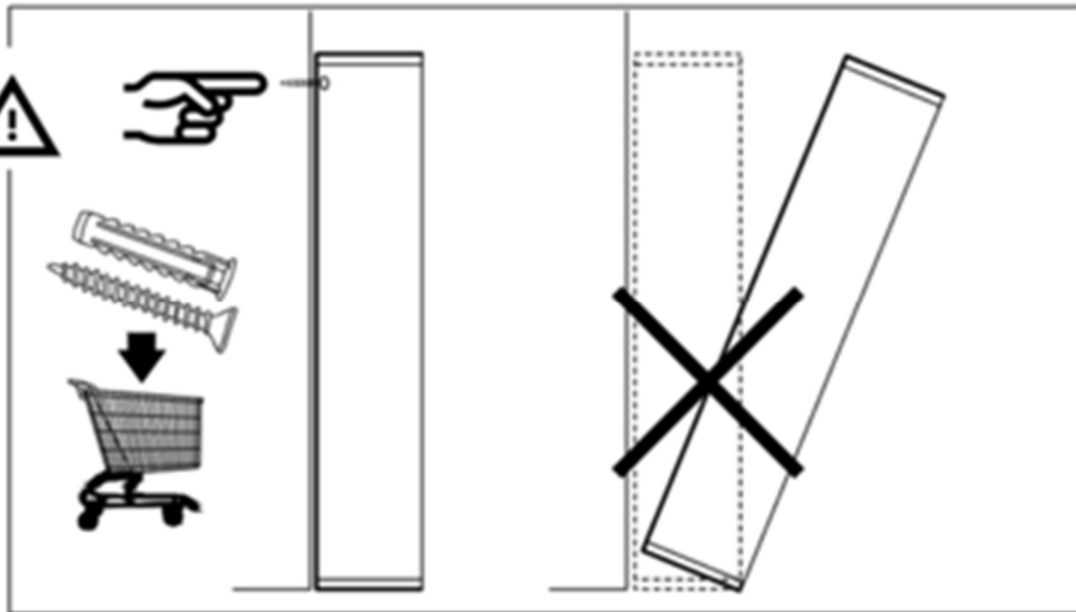

### **Wandbefestigung / wall mounting**

DE German

Aus Sicherheitsgründen muss eine Kippsicherung angebracht werden. Bitte prüfen Sie zuerst die Beschaffenheit der Hauswand. Entsprechend der Beschaffenheit besorgen Sie bitte passende Materialien, wie Wanddübel und Schrauben, in einem Fachmarkt.

GB England

For safety reasons, an anti-tip device must be fitted. Please check the condition of the house wall first. According to the condition, please obtain suitable materials, such as wall plugs and screws, in a specialist store.

FR France

Pour des raisons de sécurité, un dispositif anti-basculement doit être installé. Veuillez d'abord vérifier la qualité du mur de la maison. En fonction de la qualité, veuillez vous procurer le matériel adéquat, comme les chevilles murales et les vis, dans un magasin spécialisé.

IT Italy

Per ragioni di sicurezza, un dispositivo antiribaltamento deve essere montato. Si prega di controllare prima le condizioni del muro della casa. A seconda delle condizioni, procuratevi i materiali adatti, come i tasselli e le viti, da un negozio specializzato.

NL Netherlands

Om veiligheidsredenen moet een anti-kantelinrichting worden aangebracht. Controleer eerst de staat van de huismuur. Afhankelijk van de toestand moet u geschikte materialen, zoals muurpluggen en schroeven, bij een speciaalzaak kopen.

#### DK Denmark

Af sikkerhedshensyn skal der monteres en anti-kipanordning.

Kontroller først husmurenes tilstand. Afhængigt af tilstanden skal du købe passende materialer, f.eks. vægpropper og skruer, i en specialforretning.

#### SE Sweden

Av säkerhetsskäl måste en tipskyddsanordning monteras.

Kontrollera först husväggens skick. Beroende på tillståndet ska du skaffa lämpliga material, t.ex. väggpluggar och skruvar, i en specialaffär.

#### NO Norway

Av sikkerhetsmessige årsaker må det monteres en vippesikring

Vennligst sjekk tilstanden til husveggen først. Avhengig av tilstanden, skaffe egnede materialer, som plugger og skruer, fra en faghandel.

#### FI Finland

Turvallisuussyistä on asennettava kallistumisenestolaite.

Av säkerhetsskäl har vi inte inkluderat något fästmaterial för antilutningsanordningen på husväggen.

Kontrollera först husväggens skick. Beroende på tillståndet ska du skaffa lämpliga material, t.ex. väggpluggar och skruvar, i en specialaffär.

#### ES Spain

Por razones de seguridad, debe instalarse un dispositivo antivuelco.

Por favor, compruebe primero el estado de la pared de la casa. Dependiendo del estado, obtenga los materiales adecuados, como tacos y tornillos, en una tienda especializada.

#### PT Portugal

Por razões de segurança, deve ser instalado um dispositivo antitombamento.

Por favor, verifique primeiro o estado da parede da casa. Dependendo da condição, por favor obter materiais adequados, tais como tampões e parafusos de parede, numa loja especializada.

#### PL Poland

Ze względów bezpieczeństwa należy zamontować urządzenie przeciwwywrotne.

Najpierw należy sprawdzić stan ścian domu. W zależności od stanu należy zaopatrzyć się w odpowiednie materiały, takie jak kołki rozporowe i wkręty, w specjalistycznym sklepie.

#### RU Russia

В целях безопасности необходимо установить устройство против опрокидывания.

Пожалуйста, сначала проверьте состояние стены дома. В зависимости от состояния, пожалуйста, приобретите подходящие материалы, такие как дюбели и шурупы, в специализированном магазине.

#### SK Slovakia

Z bezpečnostných dôvodov sa musí namontovať zariadenie proti prevráteniu. Najprv skontrolujte stav steny domu. V závislosti od stavu si v špecializovanom obchode zaobstarajte vhodné materiály, ako sú hmoždinky a skrutky.

#### CZ Czech Republic

Z bezpečnostných dôvodů je nutné namontovat zařzení proti převrácení. Nejprve zkontrolujte stav stěny domu. V závislosti na stavu si ve specializovaném obchodě opatřete vhodné materiály, jako jsou hmoždinky a šrouby.

#### SL Slovenia

Iz varnostnih razlogov je treba namestiti napravo proti prevračanju. Najprej preverite stanje hišne stene. V specializirani trgovini si glede na stanje priskrbite ustrezne materiale, kot so zidni čepi in vijaki.

#### HU Hungary

Biztonsági okokból fel kell szerelni egy felborulásgátlót. Kérjük, először ellenőrizze a házfal állapotát. Az állapottól függően, kérjük, szerezz be a megfelelő anyagokat, mint például a faldugókat és csavarokat, egy szaküzletben.

#### BG Bulgaria

От съображения за безопасност трябва да се монтира устройство против преобръщане. Първо проверете състоянието на стената на къщата. В зависимост от състоянието, моля, набавете подходящи материали, като дюбели и винтове, от специализиран магазин.

#### RO Romania

Din motive de siguranță, trebuie montat un dispozitiv anti-înclinare. Vă rugăm să verificați mai întâi starea peretelui casei. În funcție de starea în care se află, vă rugăm să vă procurați materiale adecvate, cum ar fi dopuri de perete și șuruburi, de la un magazin specializat.

#### TR Turkey

Güvenlik nedeniyle, devrilme önleyici bir cihaz kurulmalıdır. Lütfen önce evin duvarının durumunu kontrol edin. Duruma bağlı olarak lütfen özel bir mağazadan dübel ve vida gibi uygun malzemeleri temin edin.

#### GR Greece

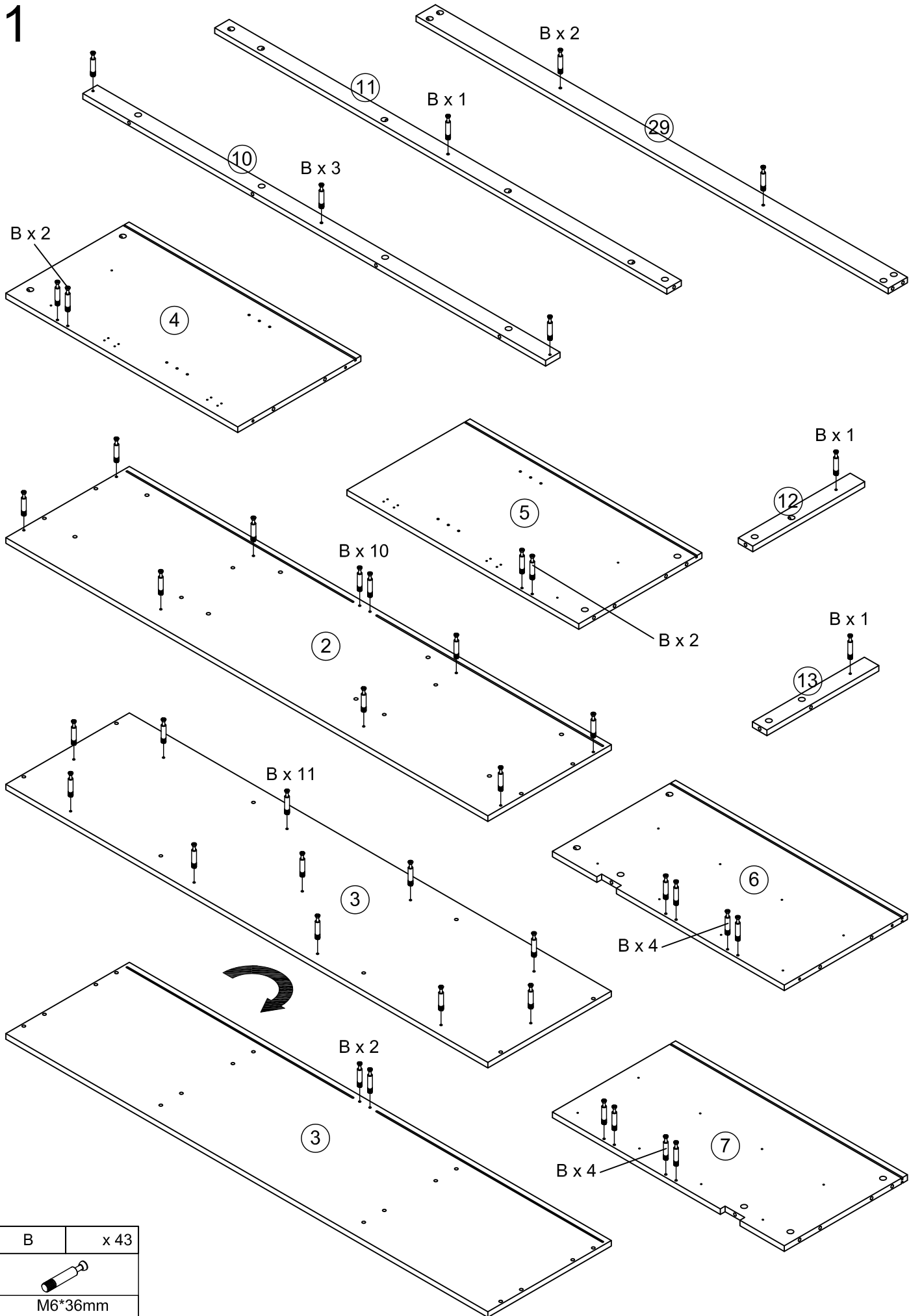

Για λόγους ασφαλείας, πρέπει να τοποθετηθεί μια διάταξη κατά της ανατροπής. Ελέγξτε πρώτα την κατάσταση του τοίχου του σπιτιού. Ανάλογα με την κατάσταση του τοίχου, προμηθευτείτε τα κατάλληλα υλικά, όπως βύσματα και βίδες, από ένα εξειδικευμένο κατάστημα.

1



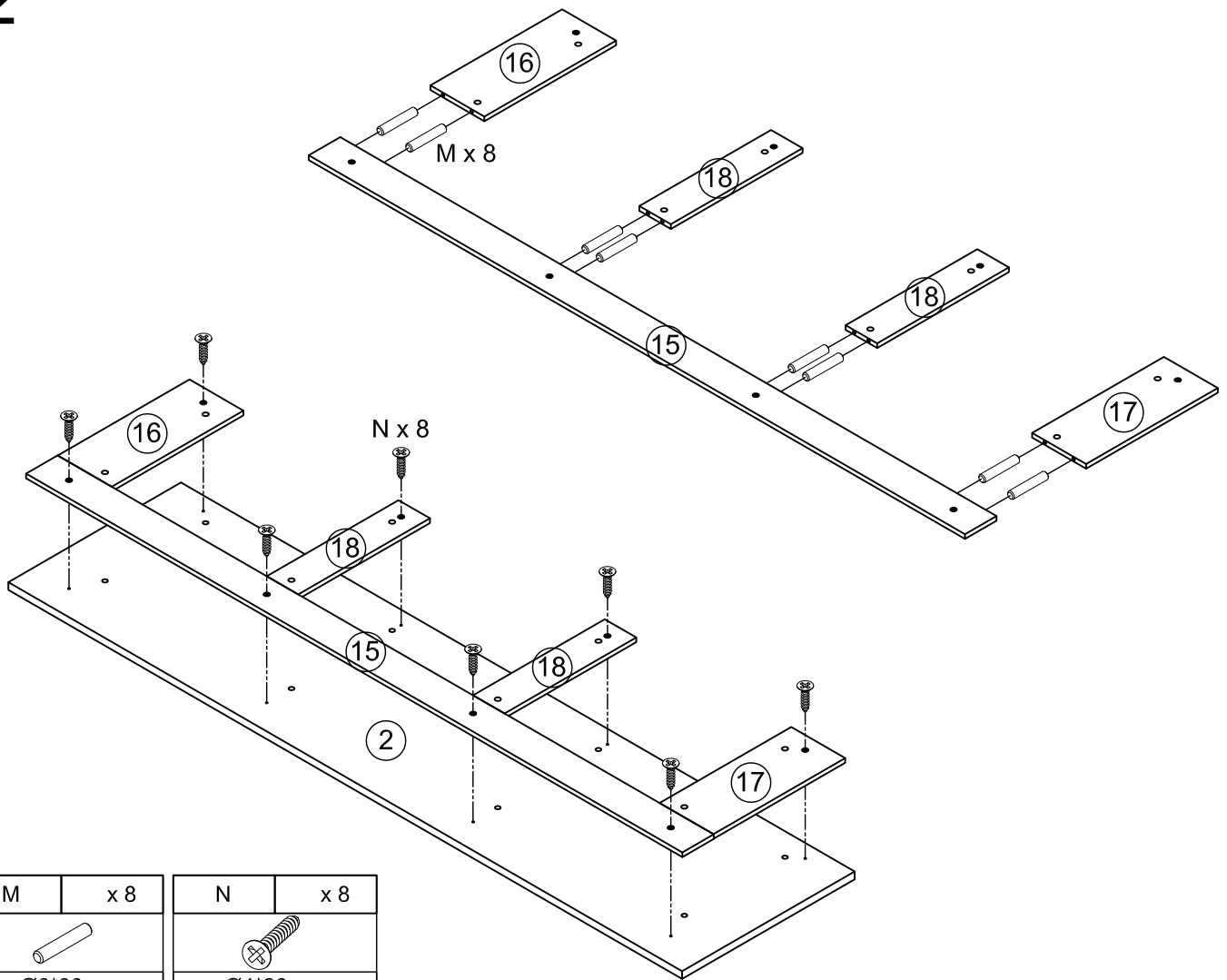



# 2

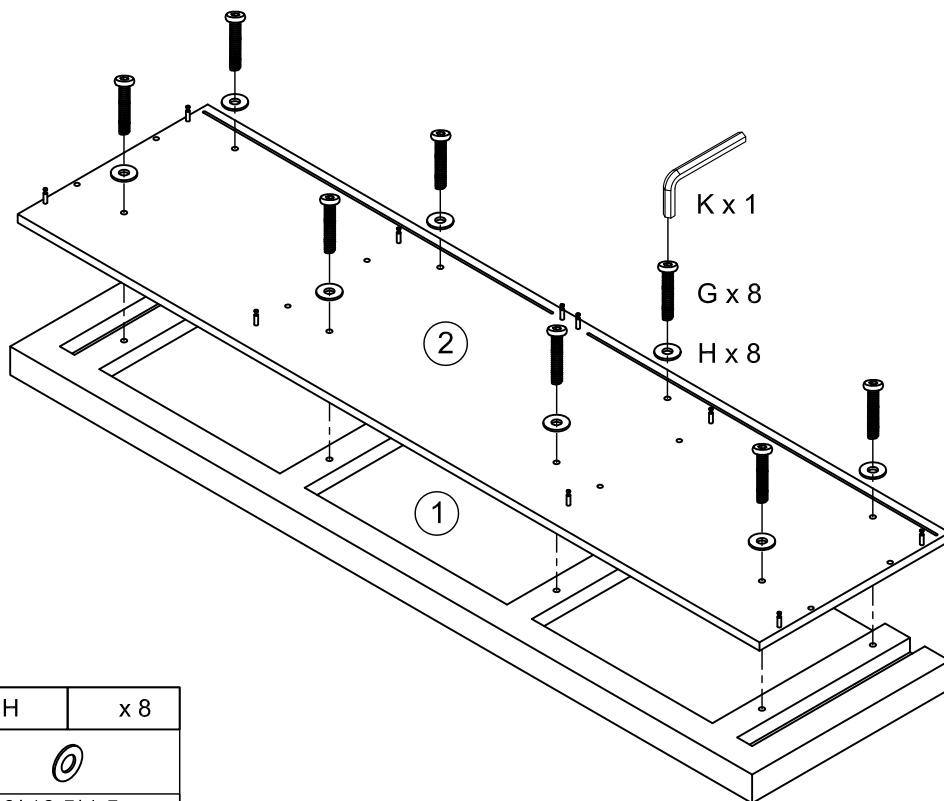

|   |     |   |     |
|---|-----|---|-----|
| M   | x 8 | N   | x 8 |
|  |     |  |     |
| Ø6*30mm   |     | Ø4*20mm   |     |

# 3



|   |     |   |     |   |     |
|---|-----|---|-----|---|-----|
| K   | x 1 | G   | x 8 | H   | x 8 |
|  |     |  |     |  |     |
| M4  |     | M6*35mm   |     | Ø13*Ø6.5*1.5mm  |     |



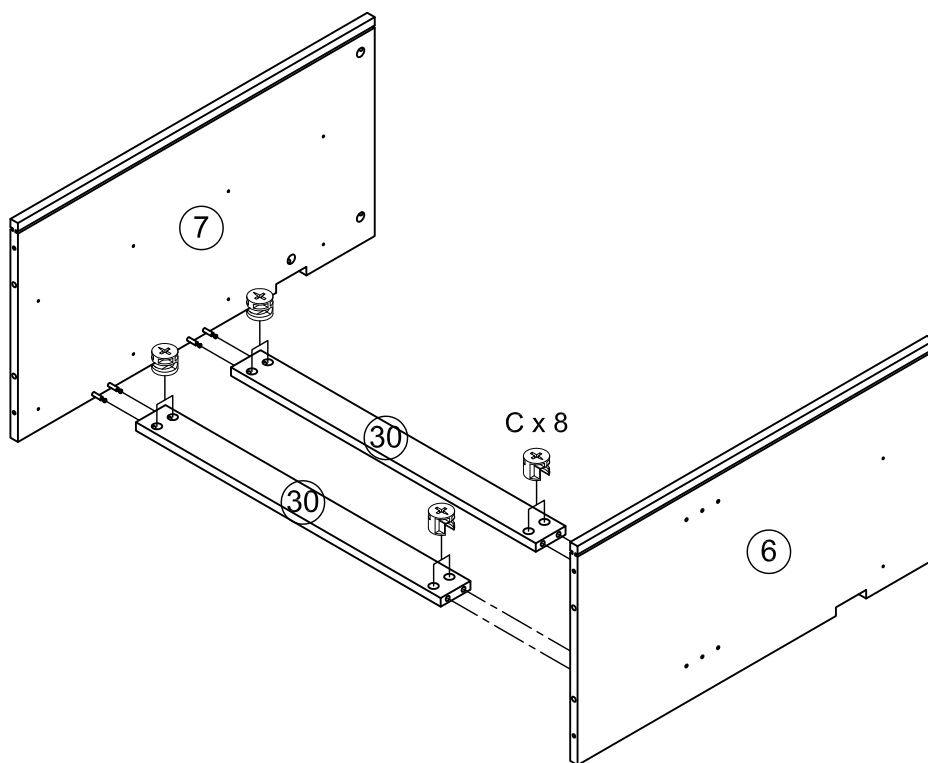

4



|   |     |
|---|-----|
| C   | x 8 |
|  |     |
| Ø15*12mm  |     |

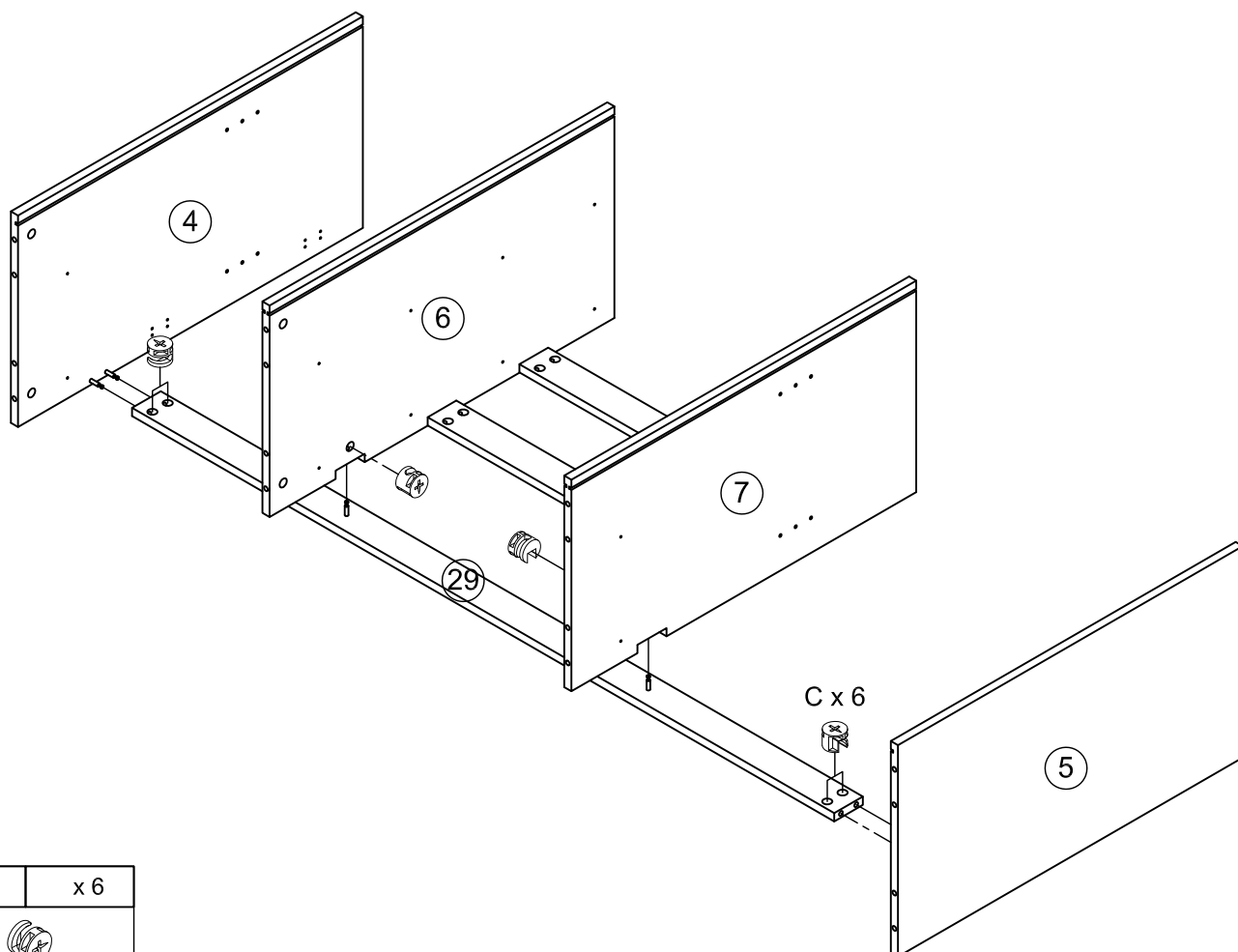

5

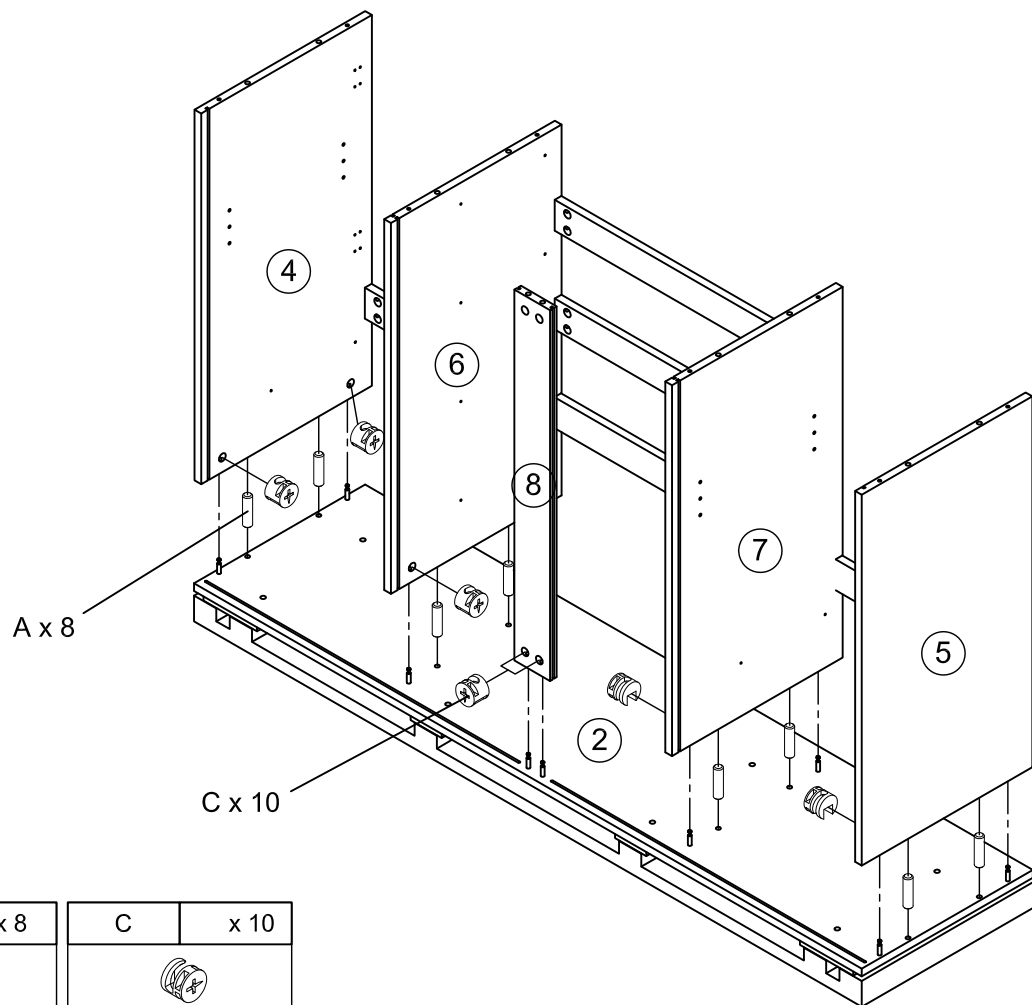

|   |     |
|---|-----|
| C   | x 6 |
|  |     |
| Ø15*12mm  |     |

# 6





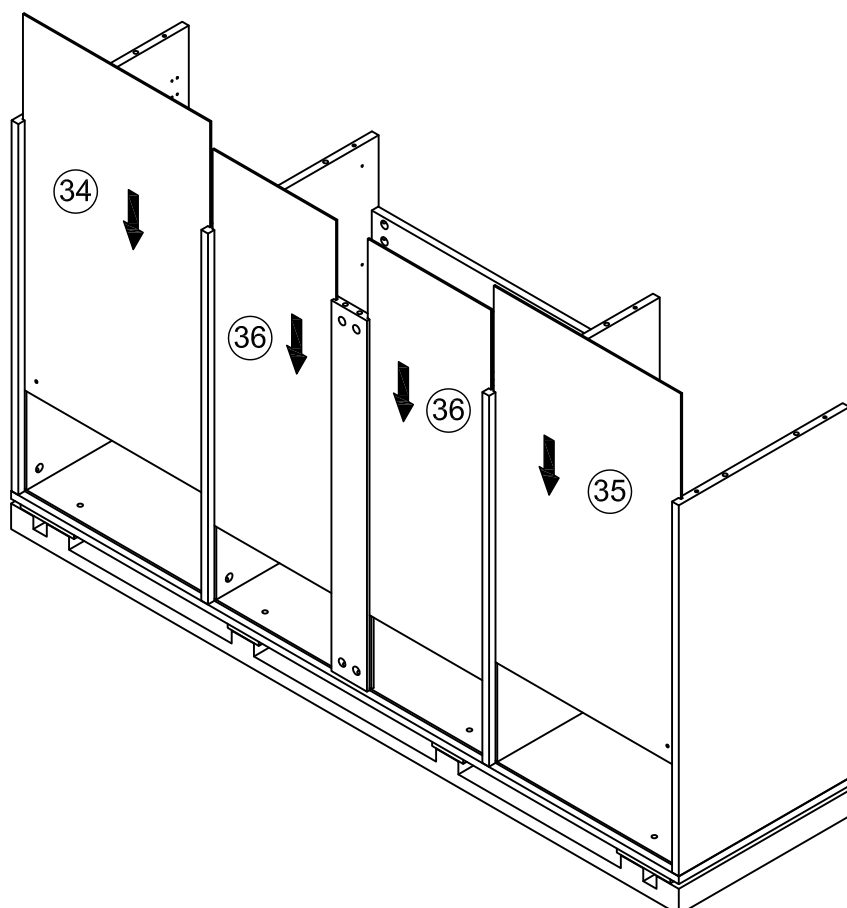

|   |     |   |      |
|---|-----|---|------|
| A   | x 8 | C   | x 10 |
|  |     |  |      |
| Ø7.8*30mm   |     | Ø15*12mm  |      |

# 7

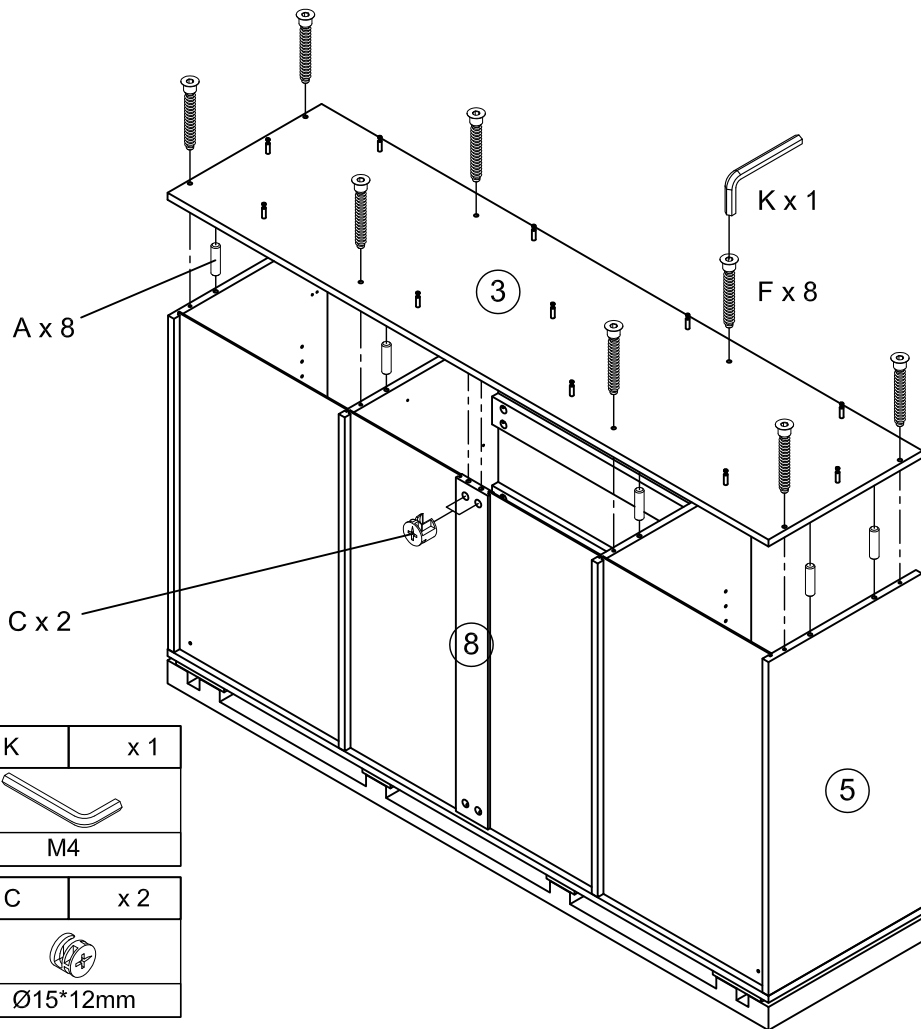



# 8

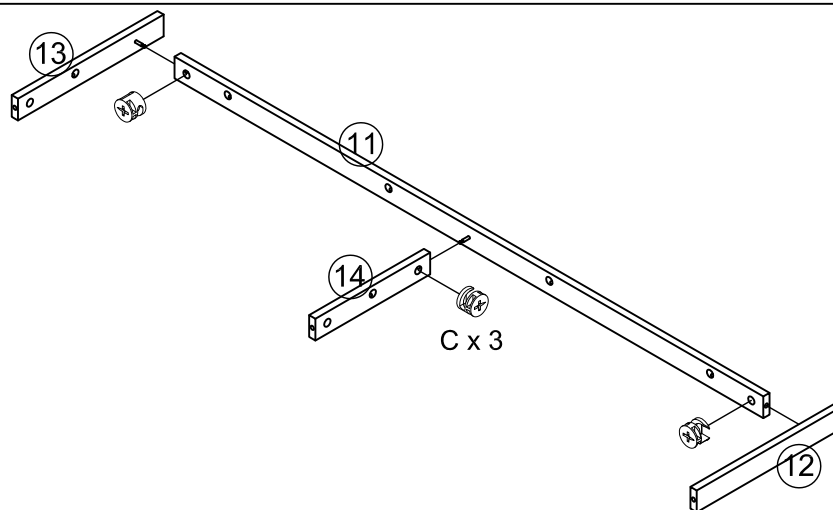

|   |     |   |     |
|---|-----|---|-----|
| F   | x 8 | K   | x 1 |
|    |     |    |     |
| M7*50mm   |     | M4  |     |
| A   | x 8 | C   | x 2 |
|  |     |  |     |
| Ø7.8*30mm   |     | Ø15*12mm  |     |

# 9



|   |     |
|---|-----|
| C   | x 3 |
|  |     |
| Ø15*12mm  |     |

# 10

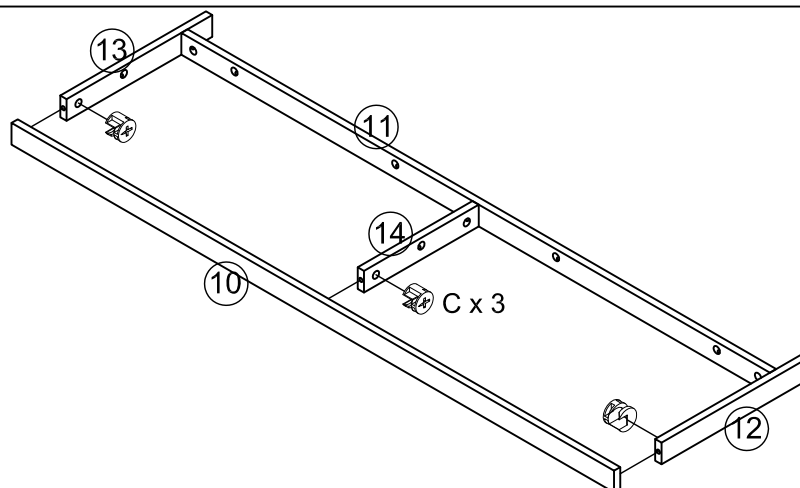

|   |     |
|---|-----|
| C   | x 3 |
|  |     |
| Ø15*12mm  |     |

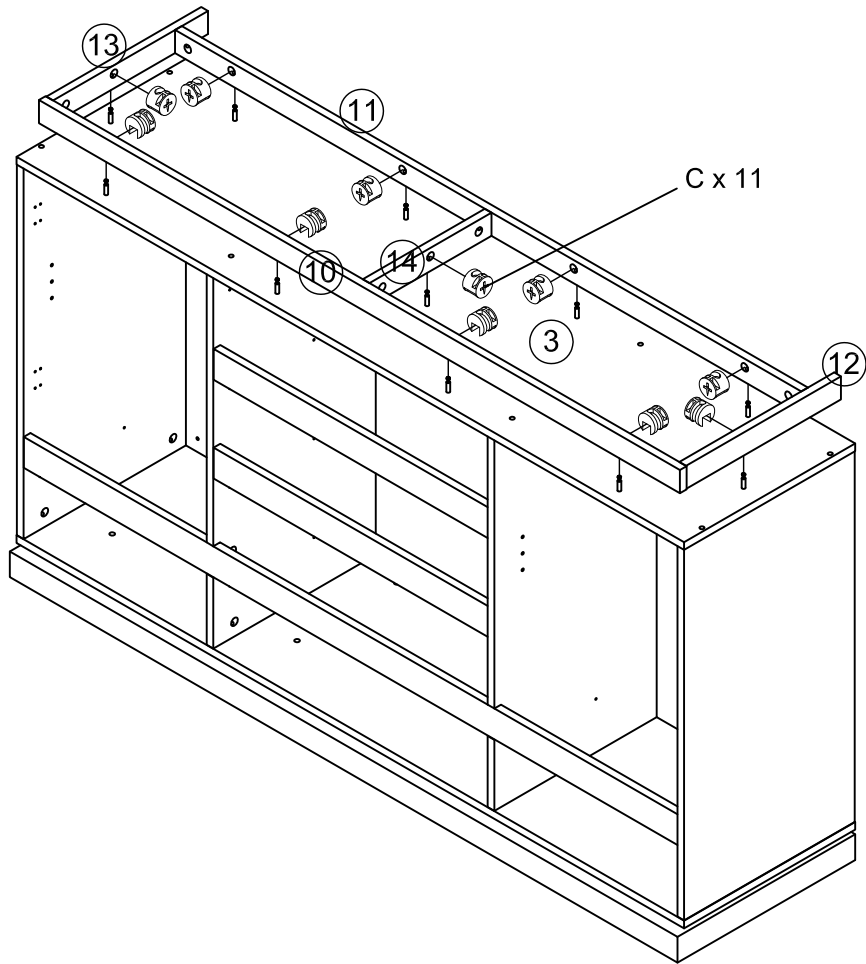

# 11

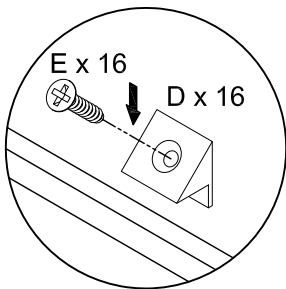
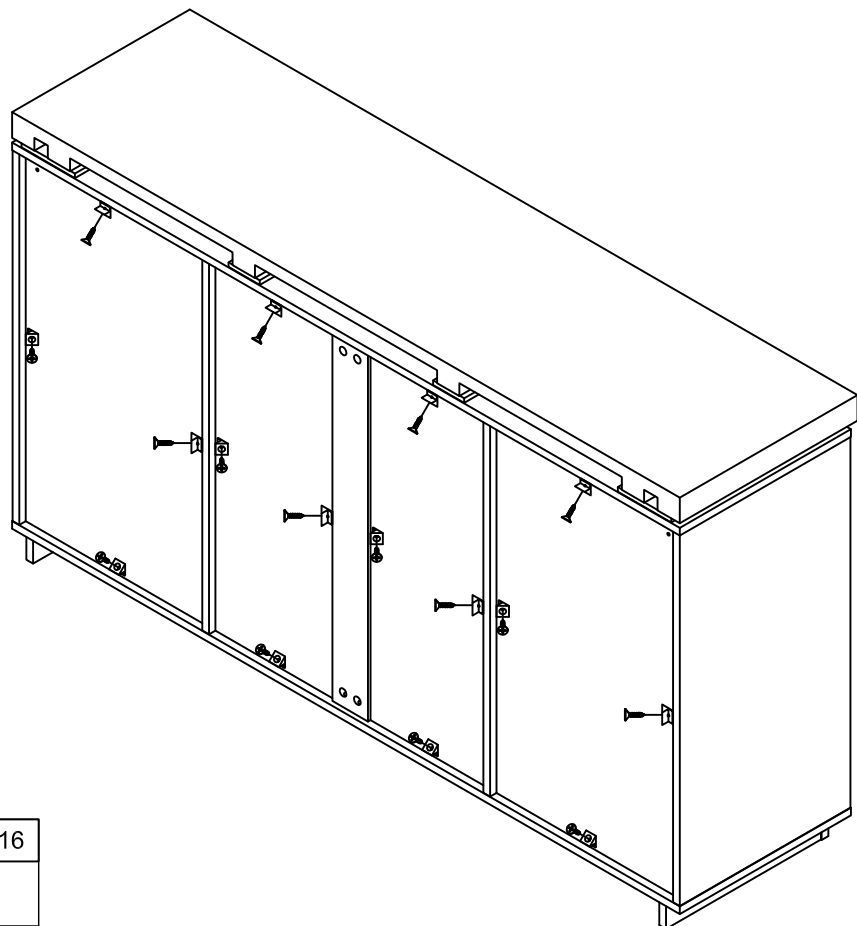

|   |      |
|---|------|
| C   | x 11 |
|  |      |
| $\text{\O}15*12\text{mm}$   |      |

# 12



|   |      |   |      |
|---|------|---|------|
| E   | x 16 | D   | x 16 |
|  |      |  |      |
| $\text{\O}3.5*12\text{mm}$  |      | $14*14*9\text{mm}$  |      |

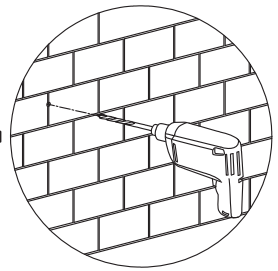
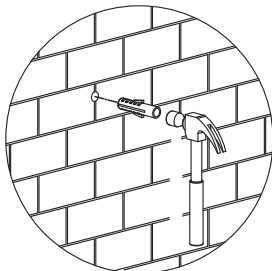
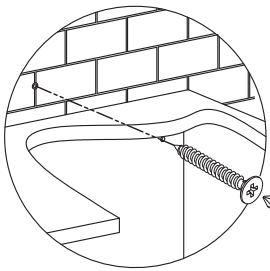
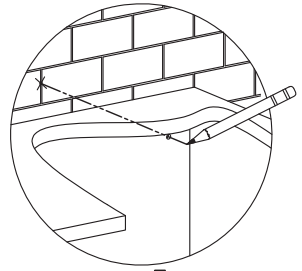
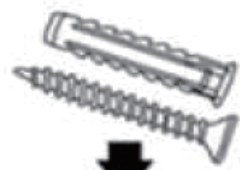
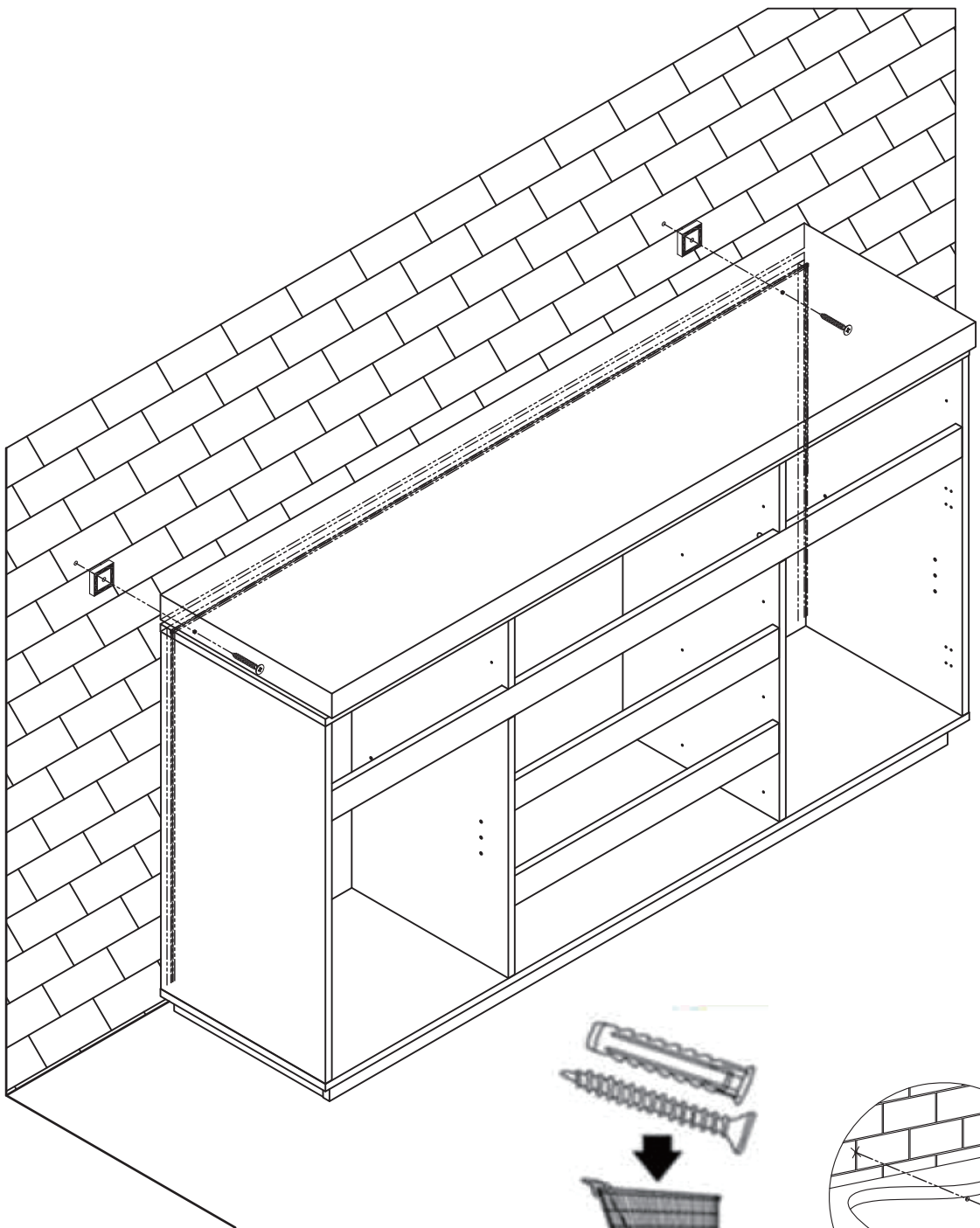

# 14

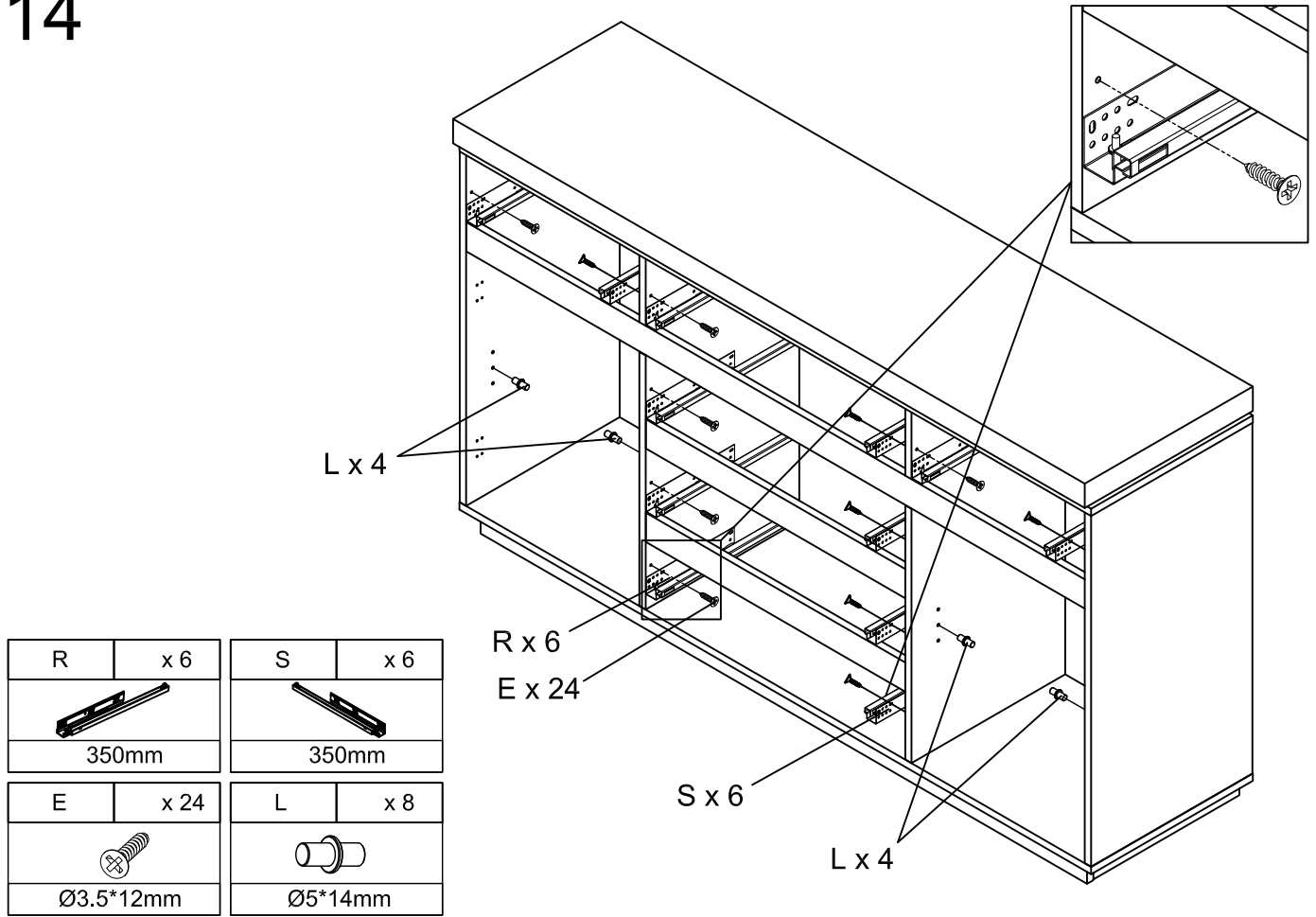

# 15

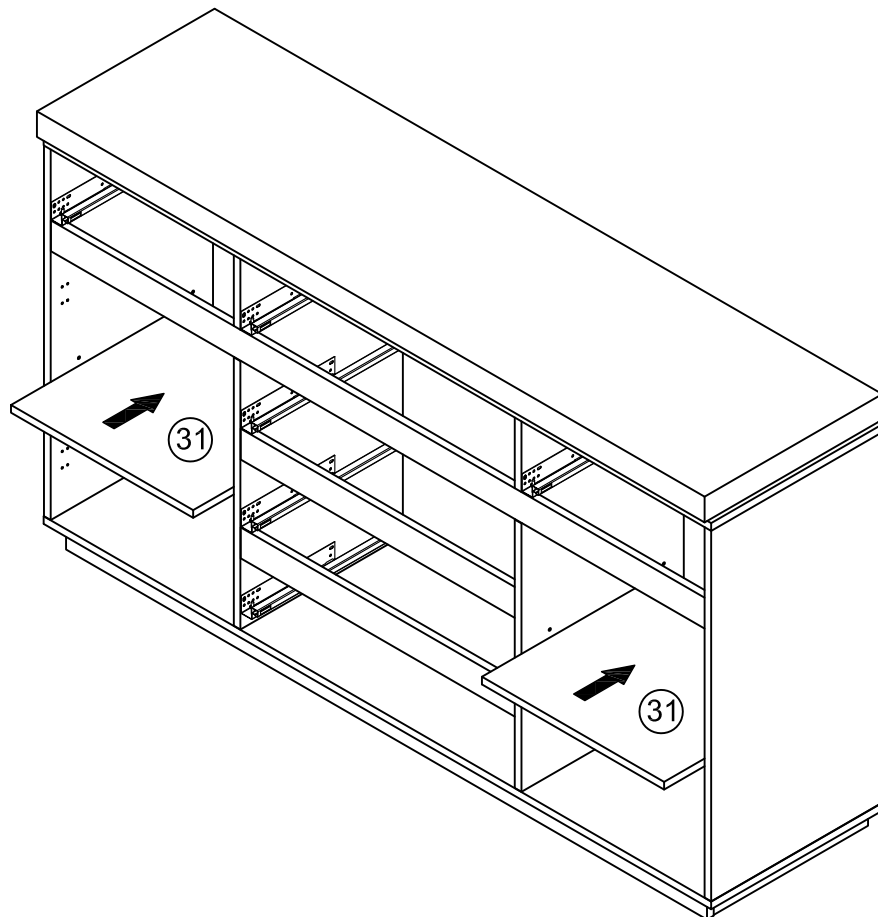

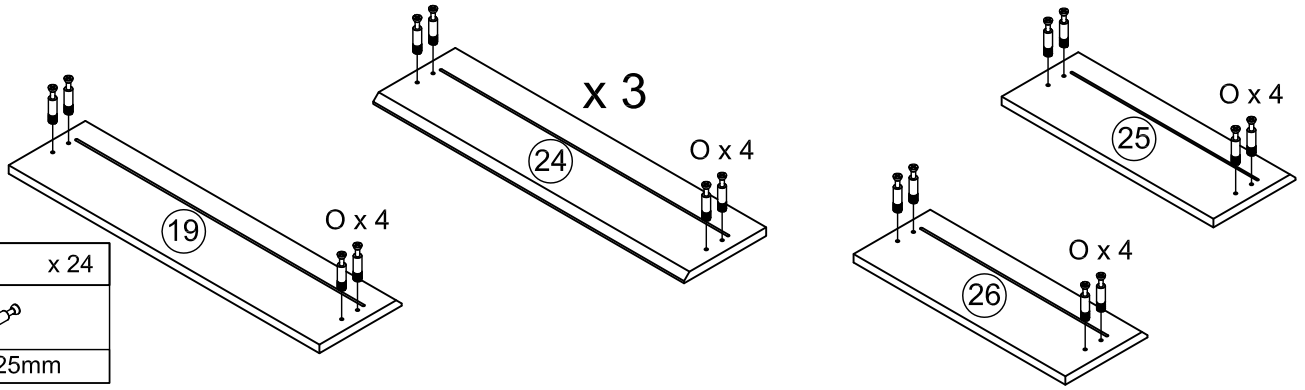

# 16

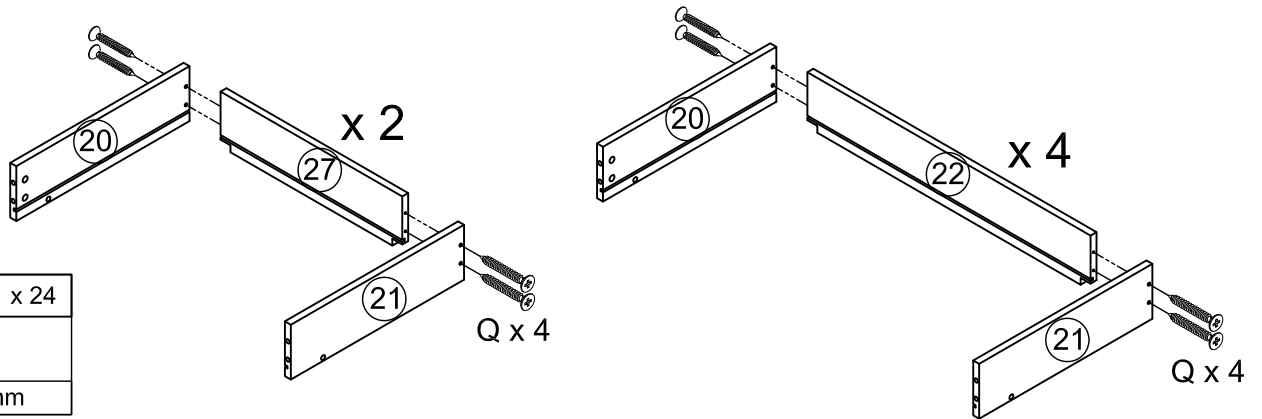

|   |      |
|---|------|
| O   | x 24 |
|  |      |
| M6*25mm   |      |

# 17



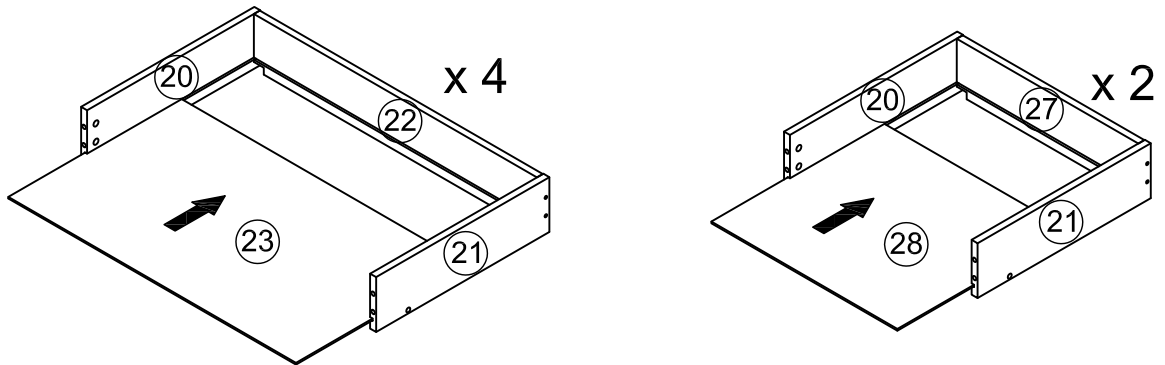

|   |      |
|---|------|
| Q   | x 24 |
|  |      |
| Ø4*30mm   |      |

# 18

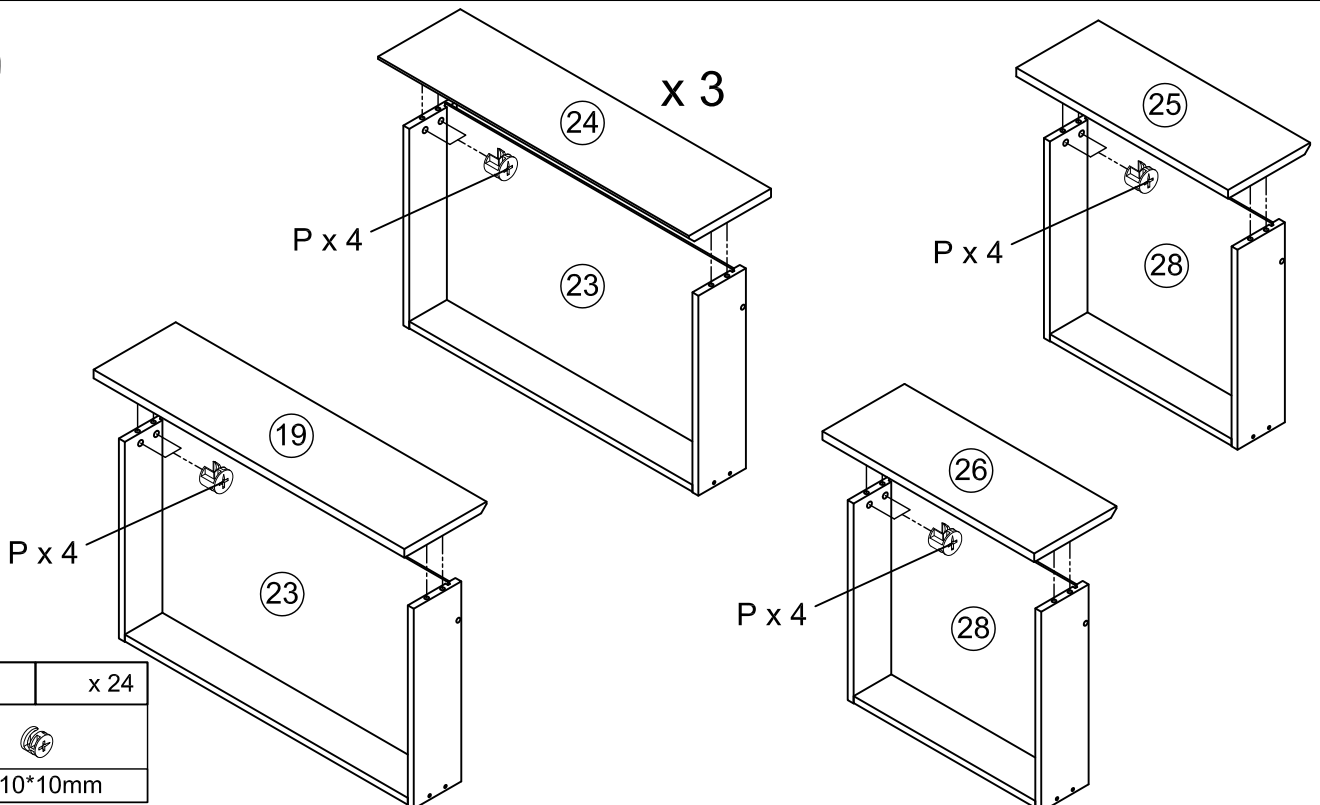

# 19



|   |      |
|---|------|
| P   | x 24 |
|  |      |
| Ø10*10mm  |      |

# 20

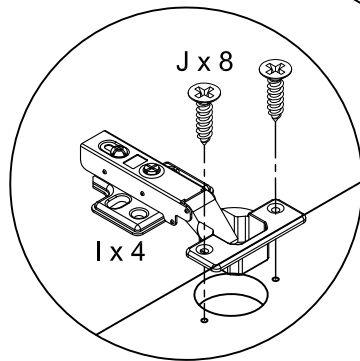
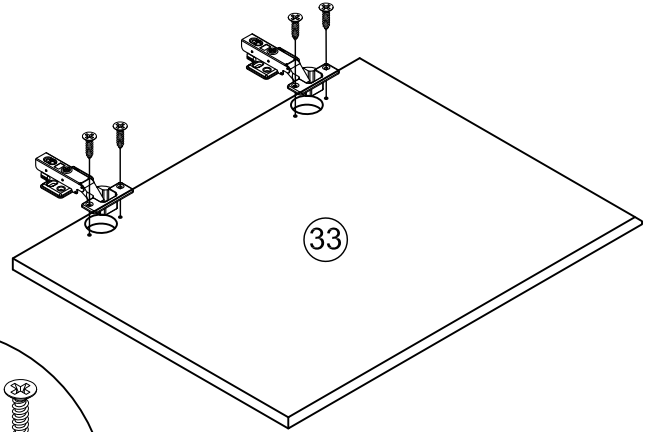
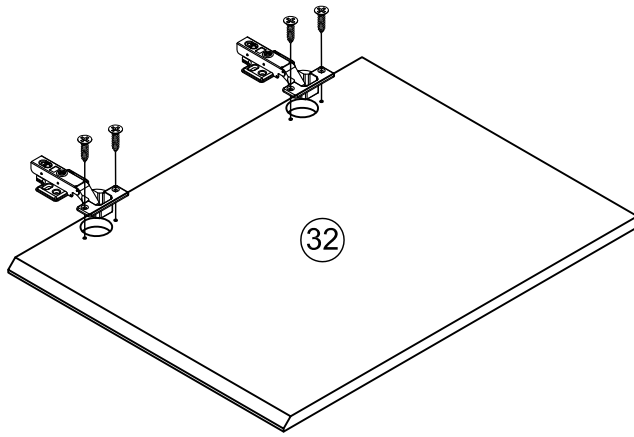

|       |     |         |     |
|-------|-----|---------|-----|
| I     | x 4 | J       | x 8 |
|       |     |         |     |
| Ø35mm |     | Ø4*15mm |     |

# 21

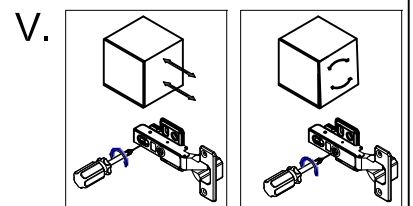
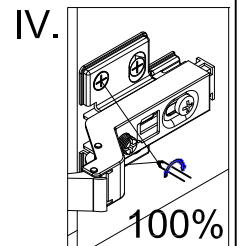
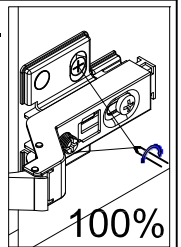
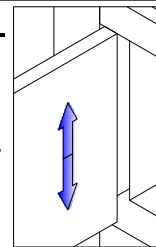
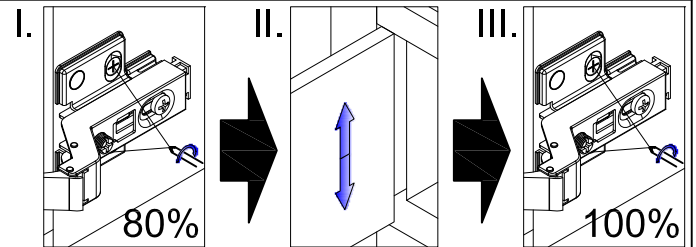
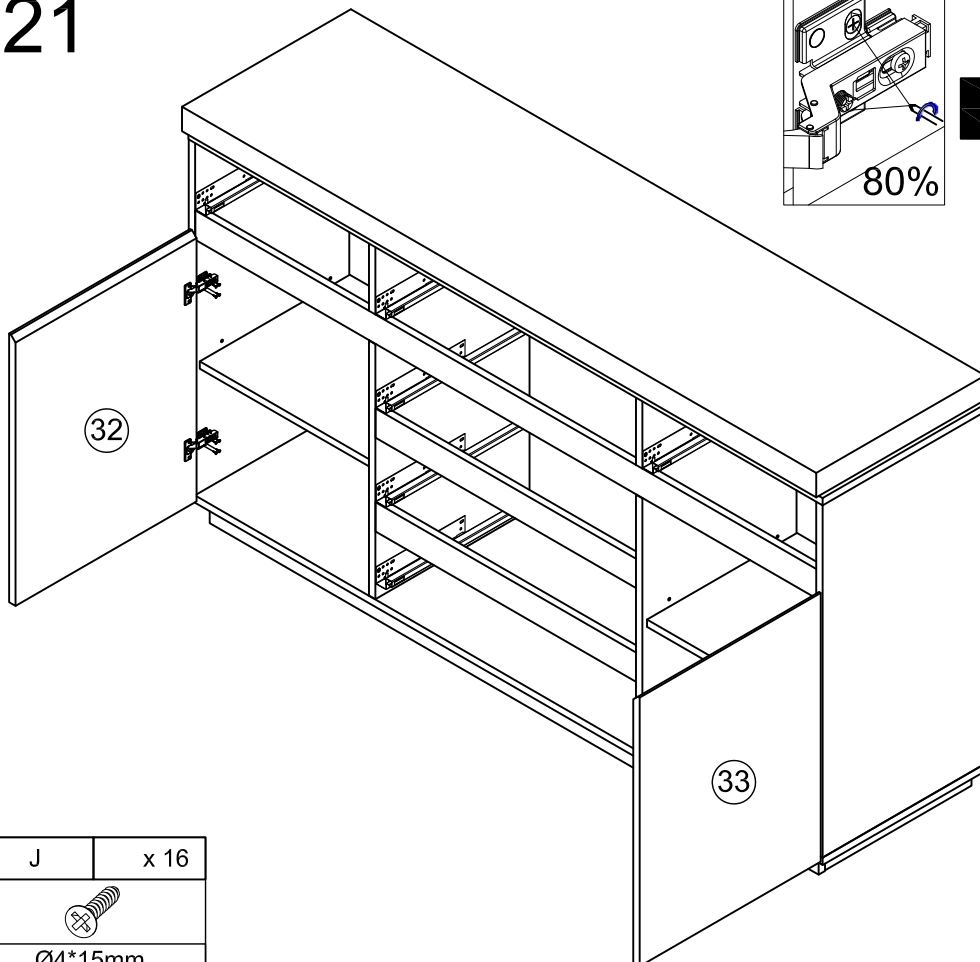

|         |      |
|---------|------|
| J       | x 16 |
|         |      |
| Ø4*15mm |      |



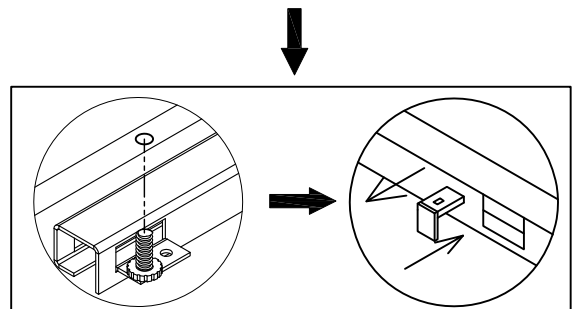
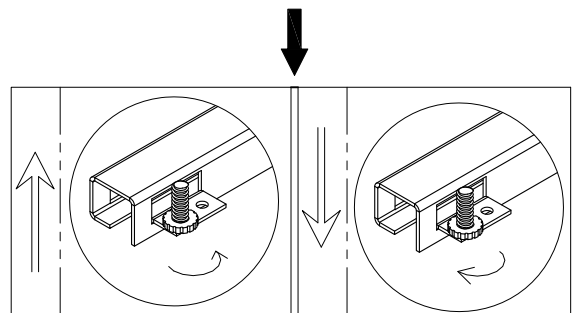
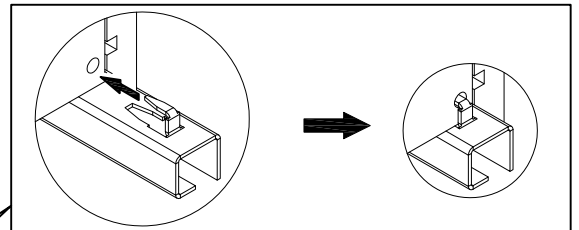
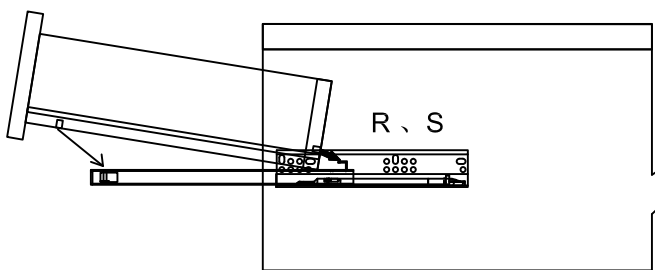
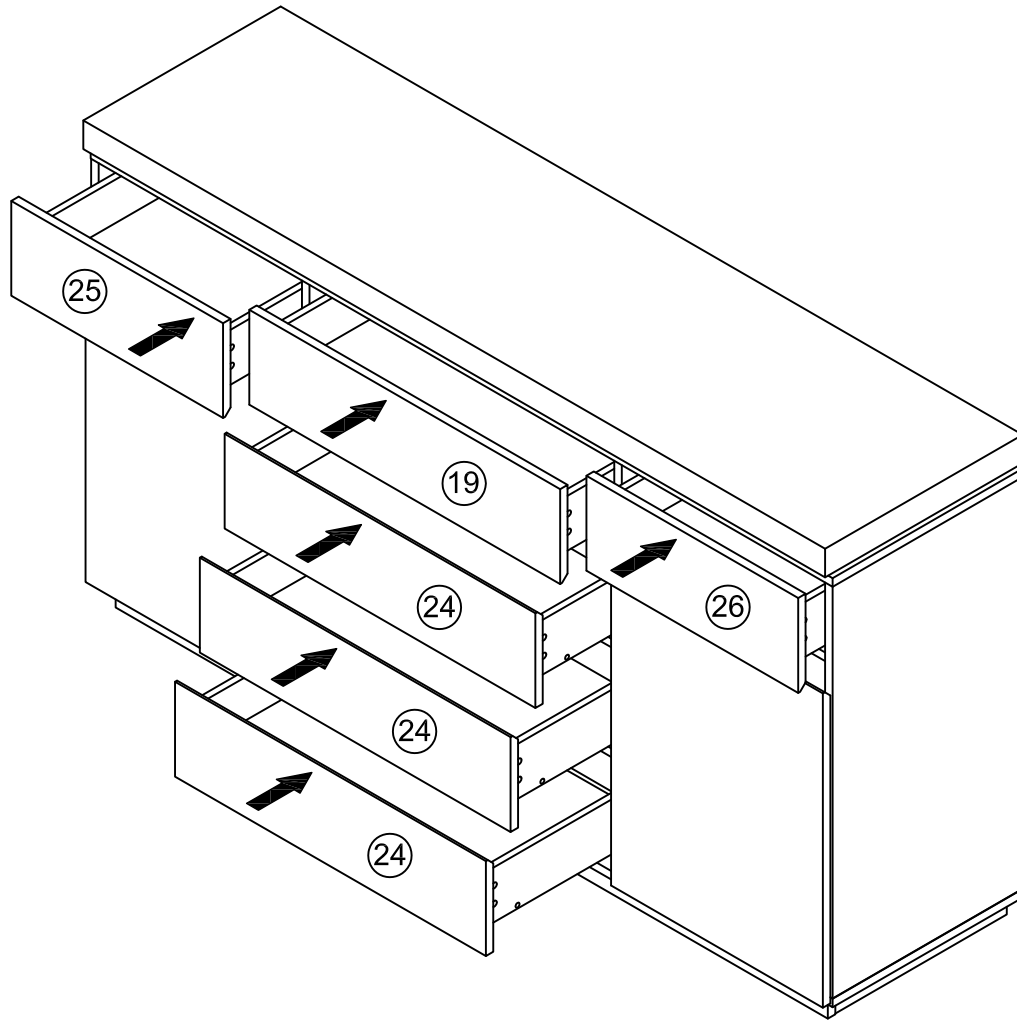



## English

Spare parts orders

Should any parts be missing or damaged, please do not forget to indicate the part designation in your order. To ensure quick processing, please send our customer service a copy of the second page on which you mark the part in question with a cross.

Safety instructions

- Packaging material such as plastic bags does not belong in children's hands. Keep the packaging material out of the reach of children.
  - The best way to care for your furniture is to use a soft, lint-free cloth or a leather cloth.
- Wipe the surface with a damp cloth.
- Do not use any microfibre cloths, dirt erasers or aggressive chemical substances.

## Deutsch

Ersatzteilbestellung

Sollten Teile fehlen oder beschädigt sein, bitte bei der Bestellung unbedingt die Teilebezeichnung angeben. Für eine schnelle Abwicklung senden Sie bitte eine Kopie der zweiten Seite an unseren Kundendienst, auf der Sie das reklamierte Teil ankreuzen.

Sicherheitshinweise

- Verpackungsmaterial wie z.B. Folienbeutel gehören nicht in Kinderhände. Bewahren Sie das Verpackungsmaterial für Kinder unerreichbar auf.
- Verwenden Sie zur Pflege Ihres Möbels am besten ein weiches, nicht fußelndes Tuch oder ein Ledertuch. Wischen Sie die Oberfläche leicht feucht ab.
- Verwenden Sie keine Microfasertücher, Schmutzradierer und keine scharfen chemischen Substanzen

## Svenska

Beställning av reservdelar

Om delar saknas eller är skadade ska alltid beteckningarna av reservdelarna anges vid beställningarna. För att kunna hantera ärendet snabbt, vänligen skicka en kopia av den andra sidan, där

du har kryssat för den reklamerade delen, till vår kundtjänst.

Säkerhetsanvisningar

- Förpackningsmaterial som t.ex. foliepåsar ska hållas bort från barn. Förvara förpackningsmaterialet oåtkomligt för barn.
  - Använd helst en mjuk och luddfri trasa eller en lädertrasa för skötseln av dina möbler.
- Torka av ytan med en lätt fuktig trasa.
- Använd inga mikrofiberdukar, skursvampar eller starka kemiska ämnen.

## FRANÇAIS

Commande de pièces de rechange

Si des pièces sont manquantes ou endommagées, veuillez impérativement indiquer la dénomination des pièces lors de la commande. Afin d'assurer un traitement rapide de votre commande, veuillez envoyer une copie de la page 2 à notre service client en cochant la pièce faisant l'objet de la réclamation.

Consignes de sécurité

- Ne pas laisser les matériaux d'emballage comme les sachets en film flexible à la portée des enfants. Veuillez conserver les matériaux d'emballage hors de la portée des enfants.
- Utilisez un chiffon doux non pelucheux ou une peau de chamois pour l'entretien de vos meubles. Essuyez la surface avec un chiffon/une peau de chamois légèrement humide.
- Ne pas utiliser de chiffons en microfibras, de gomme nettoyante ni de produits chimiques agressifs.

## Nederlands

Bestellen van vervangingsonderdelen

Indien onderdelen ontbreken of beschadigd zijn, gelieve bij de bestelling absoluut de naam van de onderdelen op te geven. Gelieve voor een snelle afhandeling een kopie van de tweede bladzijde naar onze klantendienst te sturen, waarop u het onderdeel aankruist waarmee een probleem is.

Veiligheidsinstructies

- Verpakkingsmateriaal, zoals bv. foliezakjes, hoort niet in kinderhanden.

Bewaar het verpakkingsmateriaal buiten bereik van kinderen.

- Gebruik voor het onderhoud van uw meubelstuk bij voorkeur een zachte, pluivrije doek of een zeemleer. Wrijf het oppervlak lichtelijk vochtig af.
- Gebruik geen microvezeldoeken, speciale reinigingssponzen of scherpe chemische substanties.

## ESPAÑOL

Pedido de piezas de repuesto

En el caso de que alguna pieza presente fallos o esté dañada, es imprescindible indicar en el pedido la denominación de la misma. Para que la tramitación del pedido sea rápida, envíe por favor una copia de la segunda página donde ha marcado la pieza a reclamar a nuestro servicio de atención al cliente.

Instrucciones de seguridad

- Los materiales de embalaje como p. ej. las bolsas de plástico no son juguetes. Mantenga los materiales de embalaje fuera del alcance de los niños.
- Utilice preferentemente para el cuidado de sus muebles un paño suave y que no deje pelusas o un paño de cuero. Limpie la superficie con el paño ligeramente humedecido.
- No utilice paños de microfibra, quitamanchas o sustancias químicas abrasivas.



## Dansk

Reservedelsbestilling

Såfremt dele mangler eller er beskadigede, bedes De angive delbetegnelsen ved bestillingen. For en hurtig behandling bedes De sende en kopi af side 2 til vores kundeservice, hvorpå De har afkrydset den reklamerede del.

Sikkerhedshenvisninger

- Emballagemateriale som f.eks. folieposer må ikke komme i hænderne på børn. Emballagemateriale bør opbevares utilgængeligt for børn.
- Til pleje af møblet bør De helst anvende en blød, ikke-fnuggende klud eller et vaskeskind.

Overfladen tørrer let fugtigt af.

- Anvend ikke mikrofiberklude, snavsfjerner eller stærke, kemiske stoffer.

## Hrvatski

Naručivanje rezervnih dijelova

Ako dijelovi nedostaju ili su oštećeni, kod naručivanja obavezno navedite oznaku dijela. Za brzu obradu pošaljite kopiju druge stranice našoj Službi za korisnike na kojoj je križićem označen reklamirani dio.

Sigurnosne upute

- Ambalažni materijal (vrećica od folije) mora se držati podalje od djece. Stoga ga držite izvan dohvata djece.
- Za čišćenje namještaja upotrijebite mekanu krpicu koja ne ostavlja dlačice ili kožnatu krpicu.

Obrišite površinu malo navlaženom krpom.

- Nemojte koristiti krpe s mikrovlaknima, uklanjaju prljavštine i druge kemijski agresivne tvari.

## Italiano

Ordine di pezzi di ricambio

Qualora manchino, o siano danneggiati, dei pezzi, specificare il nome del pezzo all'ordine. Per un rapido svolgimento, si prega di inviare una copia della seconda pagina al nostro Servizio Clienti, barrando il pezzo in questione.

Avvertenze di sicurezza

- Tenere il materiale di imballaggio, quale per esempio sacchetti di plastica, fuori dalla portata dei bambini. Conservare il materiale di imballaggio fuori dalla portata dei bambini.
- Per pulire il mobile, utilizzare un panno che non lascia pelucchi o un panno in pelle.

Asciugare la superficie con un panno leggermente inumidito.

⊠ Non usare panni in microfibra, gomme per lo sporco, o sostanze chimiche aggressive.

## Polski

Zamówienie na części zamienne

W przypadku braku części lub ich uszkodzeń w zamówieniu proszę koniecznie podać oznaczenie części. W celu szybkiej realizacji reklamacji proszę przesłać do działu obsługi klienta kopię drugiej strony z zakreśloną reklamowaną częścią.

Wskazówki dotyczące bezpieczeństwa

- Materiałów opakowaniowych, np. worków foliowych, nie wolno dawać dzieciom. Materiały opakowaniowe należy trzymać w miejscu niedostępnym dla dzieci.
- Do pielęgnacji mebla najlepiej używać miękkiej, niepylącej ściereczki lub irchy.

Wycierać powierzchnię lekko zwilżoną ściereczką.

- Nie stosować ściereczek z mikrofibry, gąbek do czyszczenia brudu ani silnie działających substancji chemicznych.

## Slovensky

Objednávania náhradných dielov

Ak by diely chýbali alebo boli poškodené, pri objednávaní bezpodmienečne uvedte označenie dielu. Pre rýchlejšie vybavenie pošlite kópiu druhej strany nášmu zákazníkemu servisu, na ktorej reklamovaný diel označíte križikom.

Bezpečnostné pokyny

- Obalový materiál, ako napr. fóliové vrecká, nepatrí do rúk deťom. Obalový materiál uschovajte mimo dosahu detí.
- Na ošetrovanie nábytku použite najlepšie mäkkú handru, ktorá nepúšťa vlákna, alebo koženú utierku.

Povrch utrite jemne navlhčenou handrou.

- Nepoužívajte utierky z mikrovlákná, čistiace gummy a agresívne chemické látky.

## SLOVENŠČINA

Naročilo nadomestnih delov

Če deli manjkajo ali so poškodovani, ob naročilu nujno navedite tudi opis dela. Za hitro obdelavo zahtevka naši službi za stranke pošljite kopijo druge strani, na kateri označite reklamirani del.

Varnostni napotki

- Embalažni material, kot so plastične vrečke, ne spadajo v roke otrok. Embalažni material shranjujte zunaj dosega otrok.
- Za nego svojega pohištva uporabite mehko krpo, ki se ne kosmati, ali usnjeno krpo.

Površine obrišite z rahlo navlaženo krpom.

- Ne uporabljajte krp iz mikrovlaknen, čistilnih radirk in močnih kemičnih sredstev.