

Assembling Instruction

P1

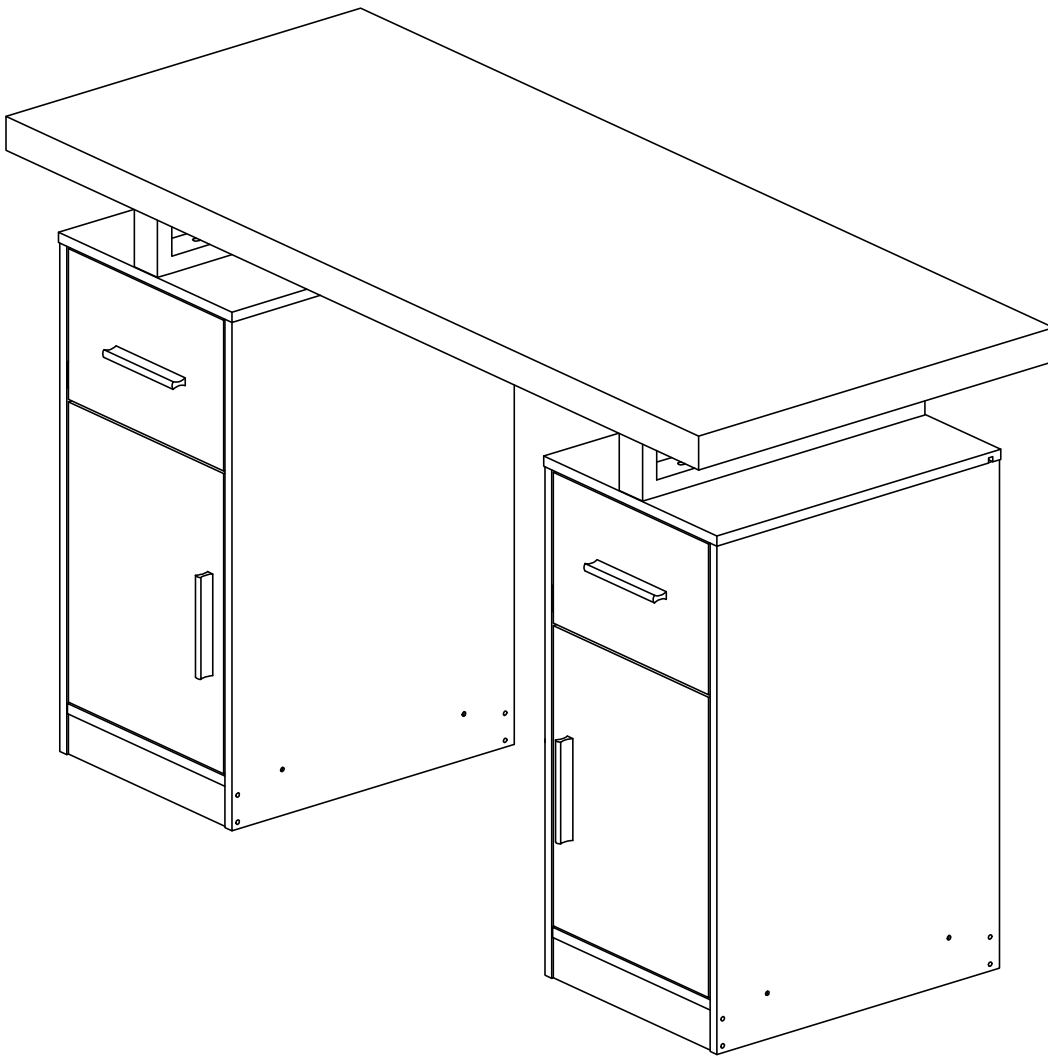

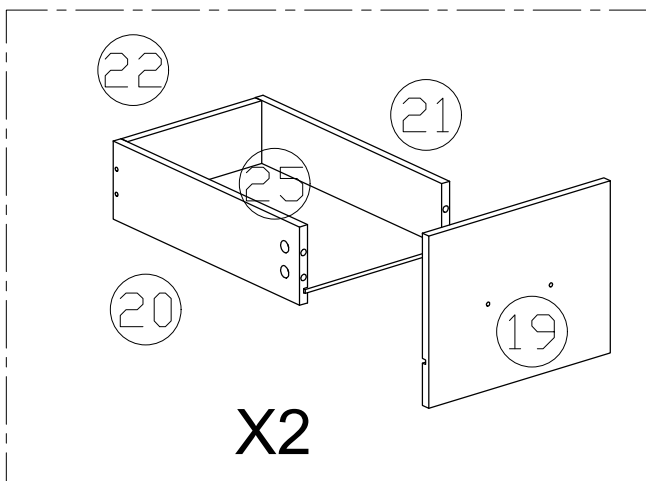

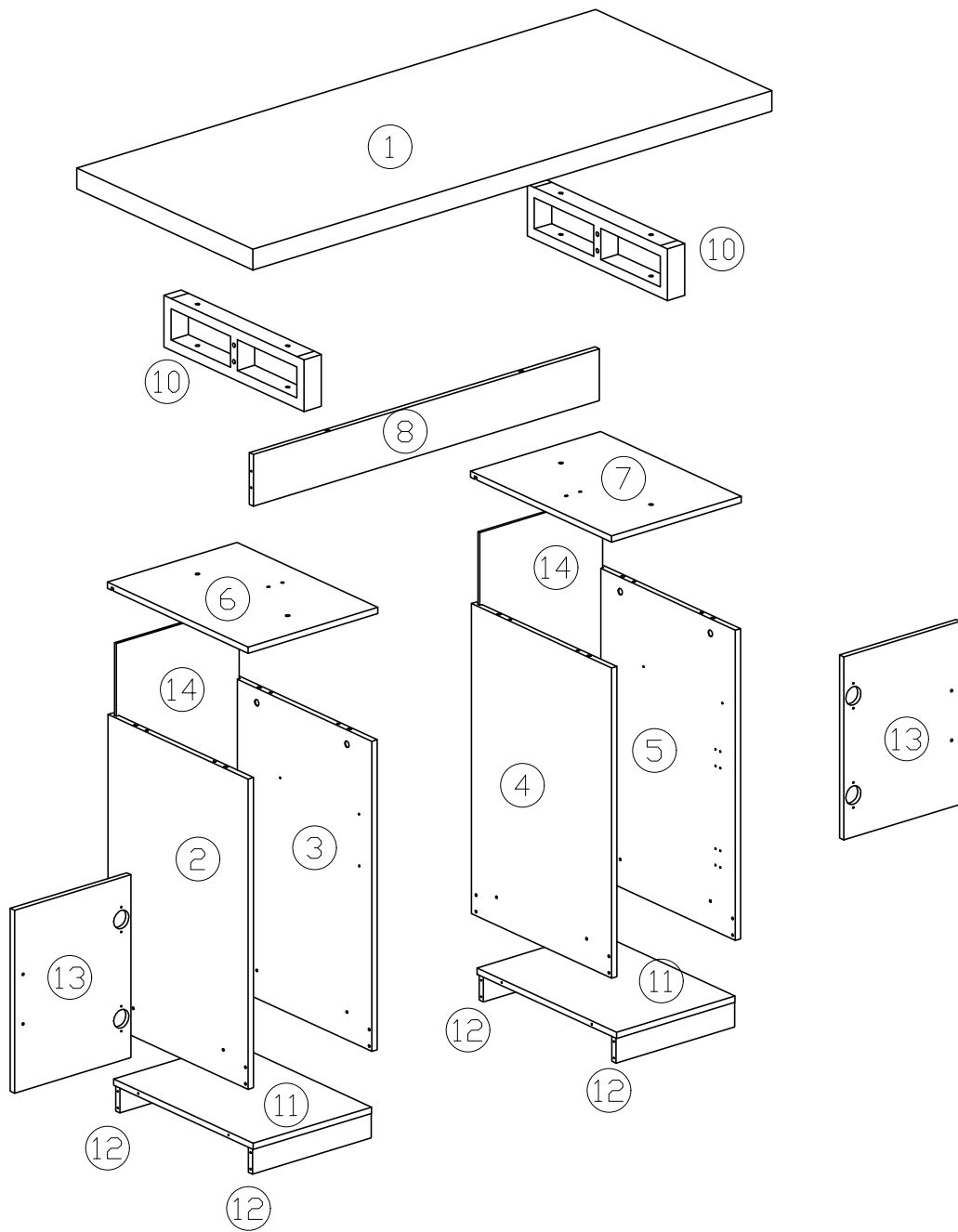



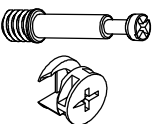

Attention: Do not tighten screws until all of them are in right positions



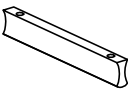

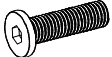

Assembling Instruction

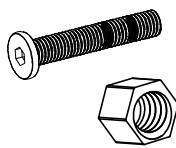
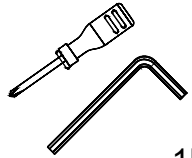
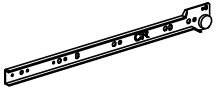
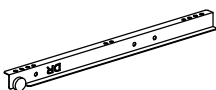
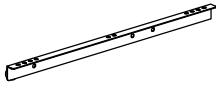
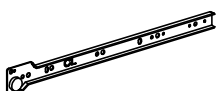
P3

A  18PCS	B  M4*30 36PCS	C  M4*12 40PCS	D  Ø6*30 8PCS
E  4PCS	F  8PCS	G  M6*30 4PCS	H  4PCS
J  M5*60 4PCS	K  2PCS	P  M6*40 4PCS	 1PCS
CR  2PCS	DR  2PCS	DL  2PCS	CL  2PCS

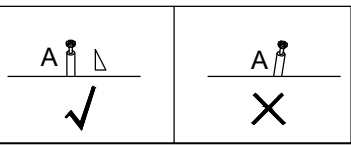
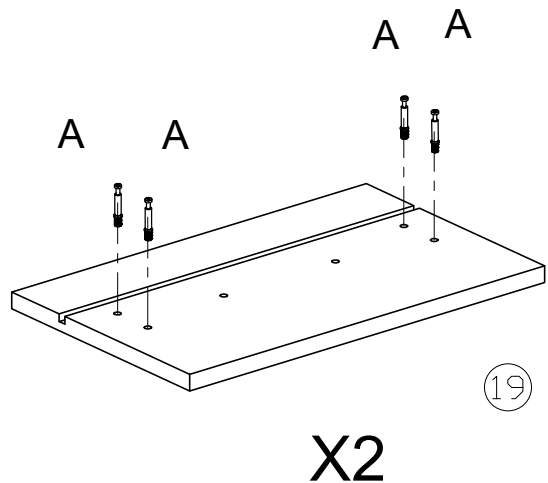
1



A		8
---	---	---

Assembling Instruction

P4

2

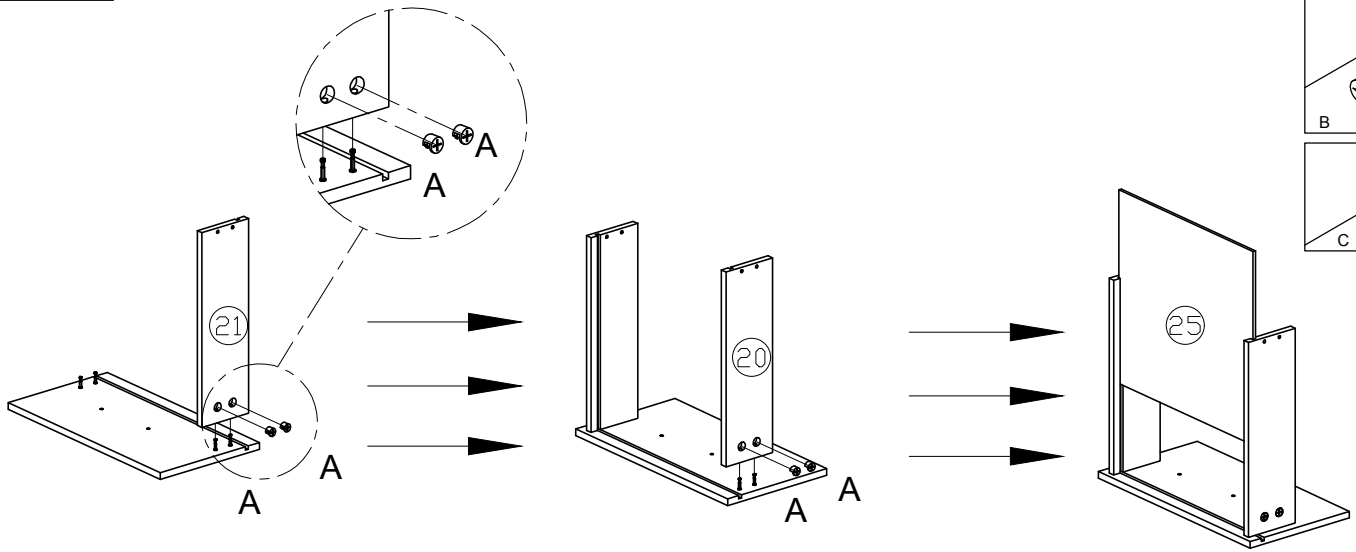

X2

A		8
---	--	---

3

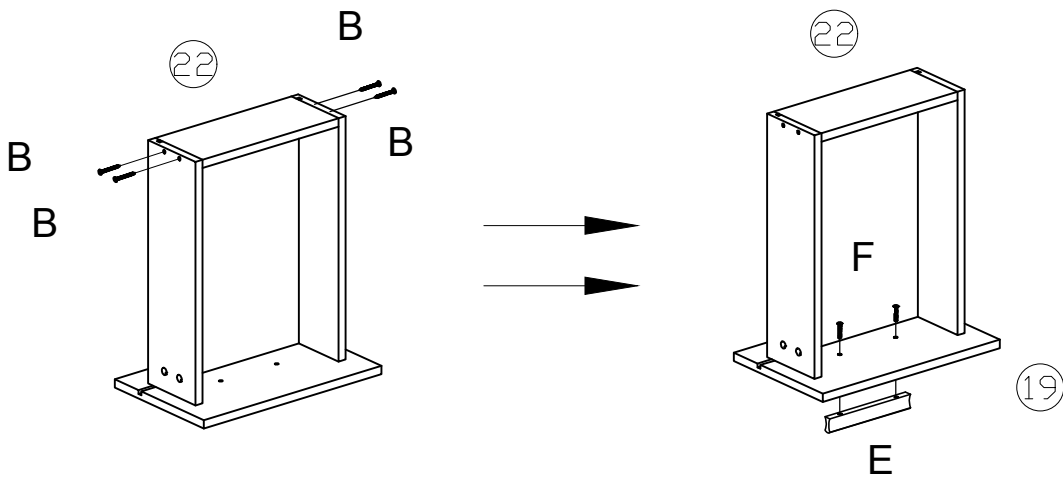



X2

E		2
F		4
B		8

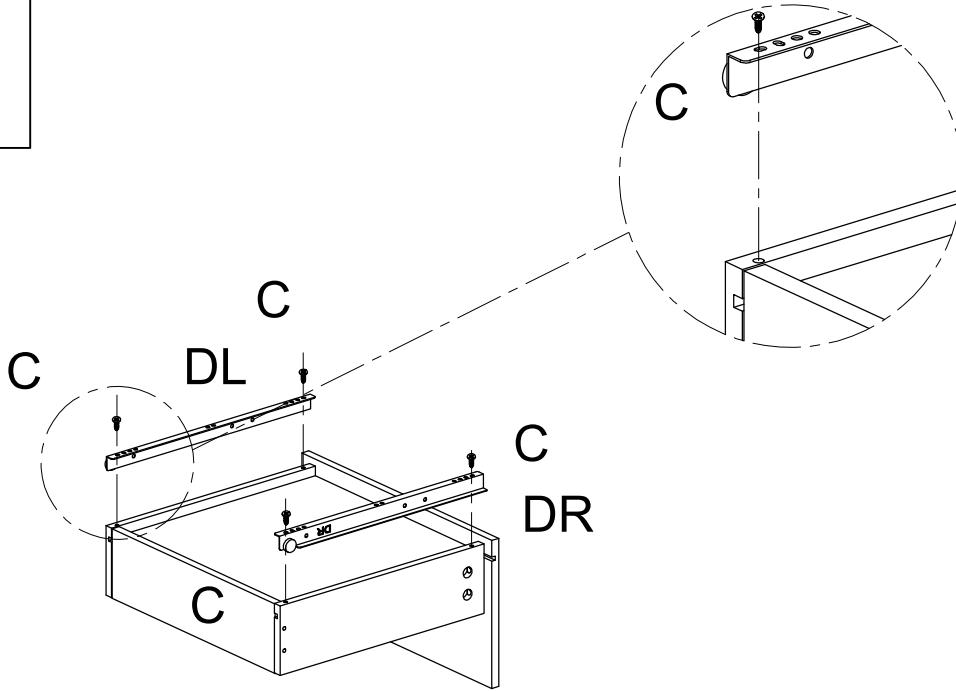
4



X2

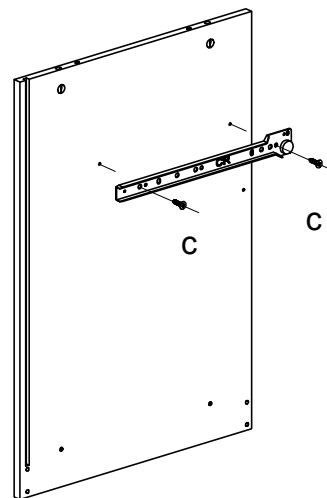
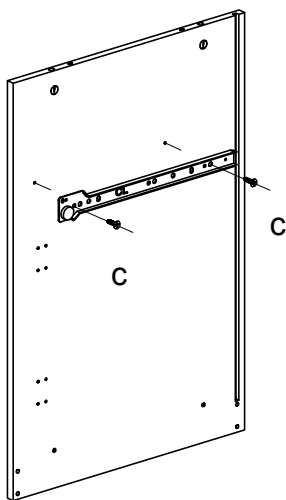
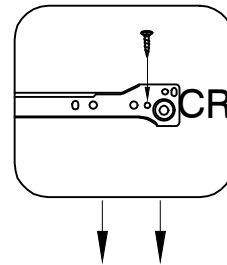
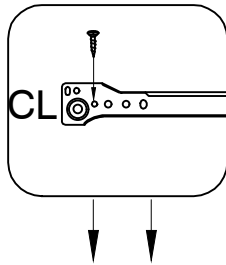

DL		2
DR		2
C		8

5



②

③



CR		1
CL		1
c		4

Assembling Instruction

P6

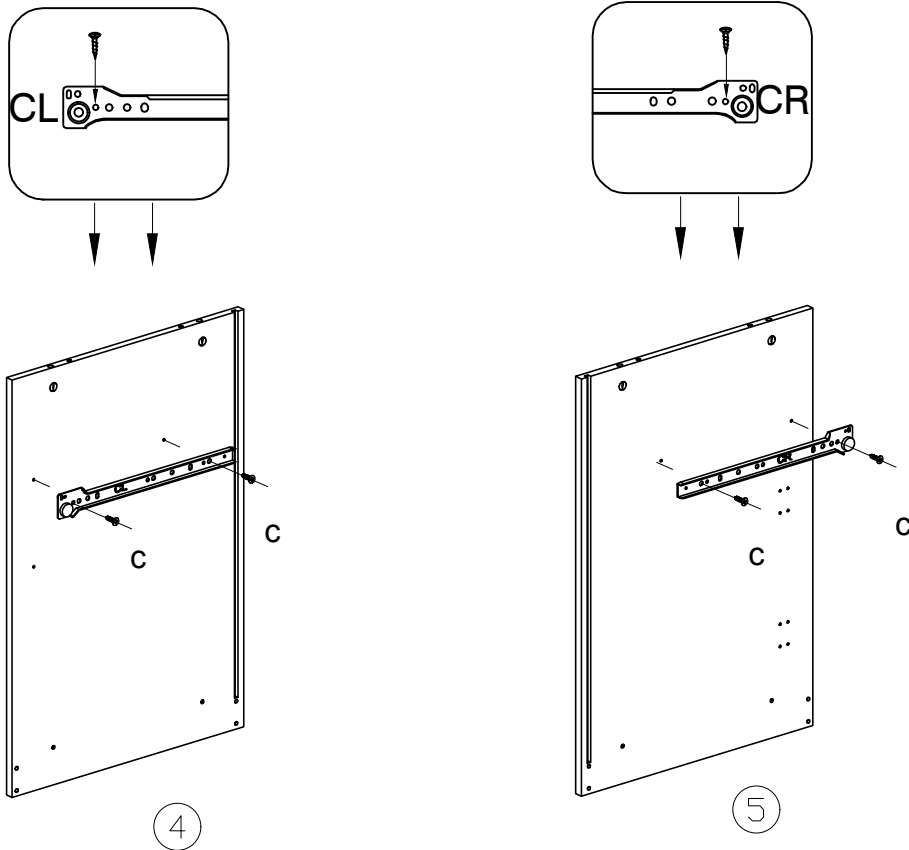
6



CR		1
CL		1
c		4

7

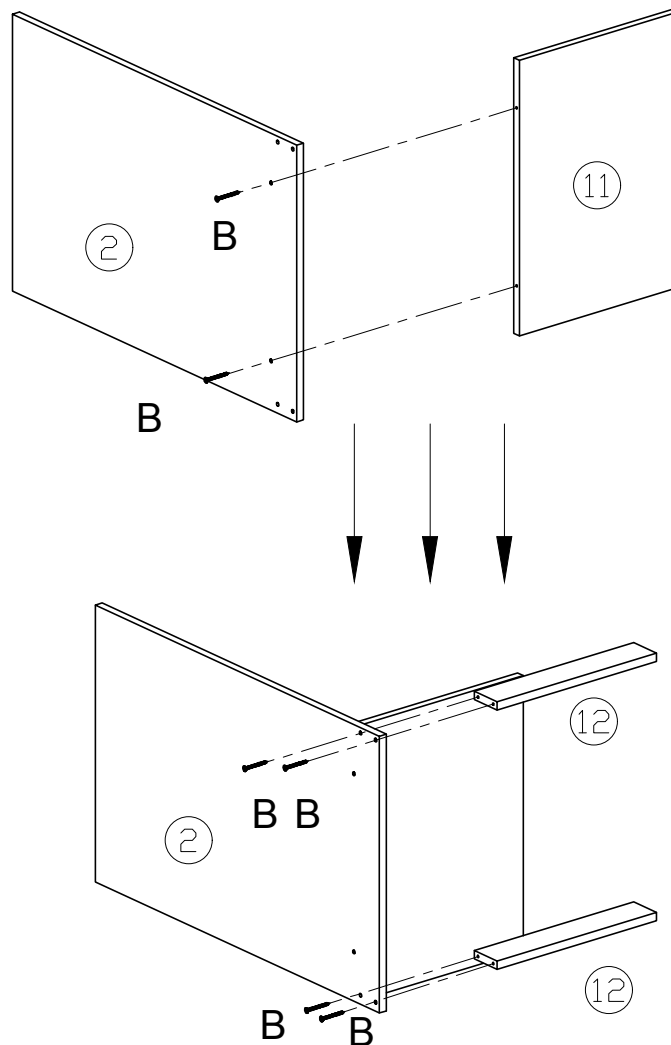

B		6
---	---	---

8

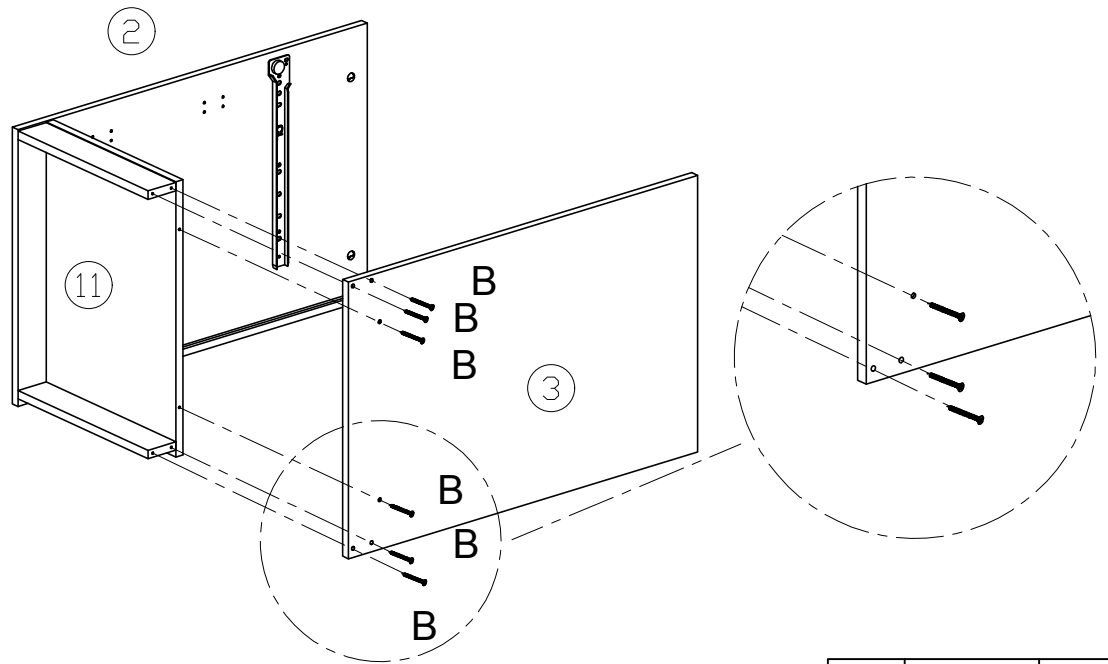

B		6
---	---	---

9

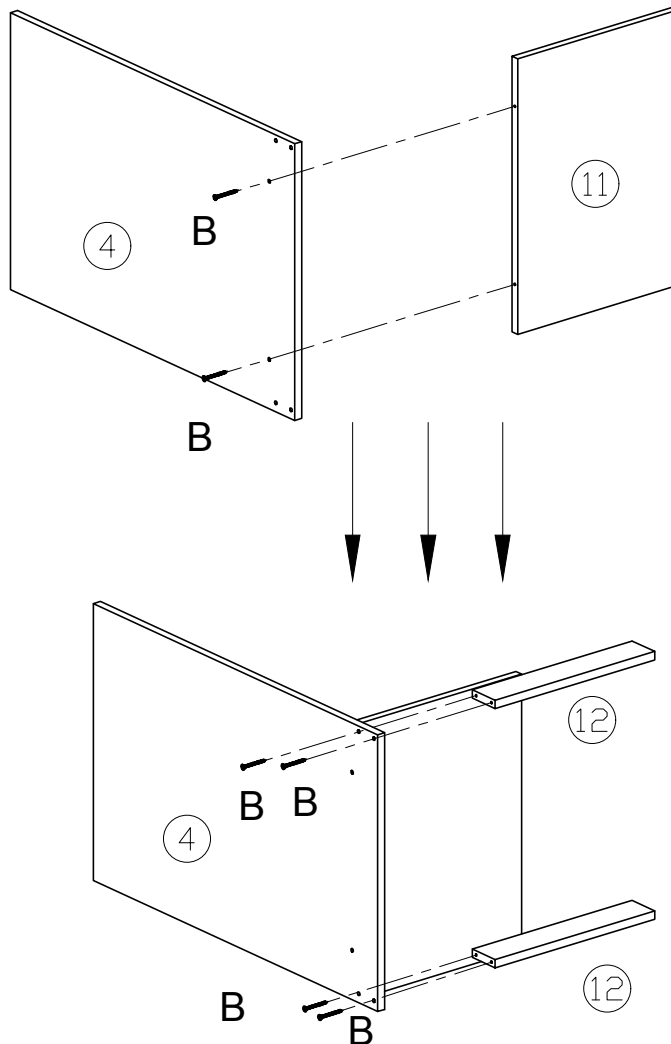

B		6
---	---	---

10

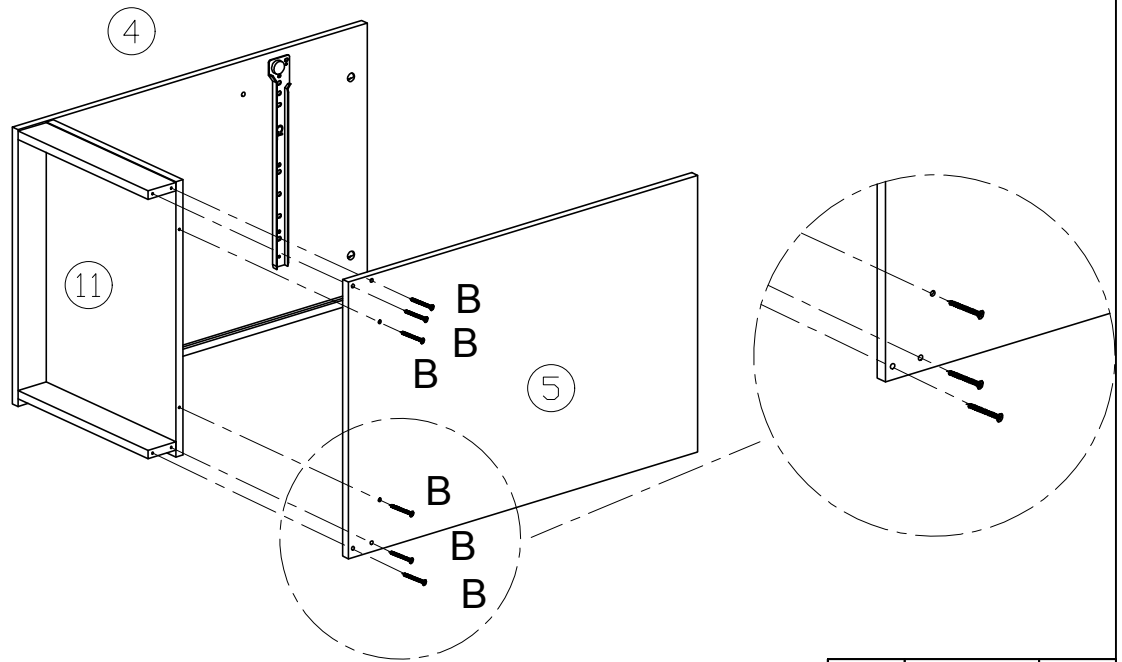

B		6
---	---	---

11

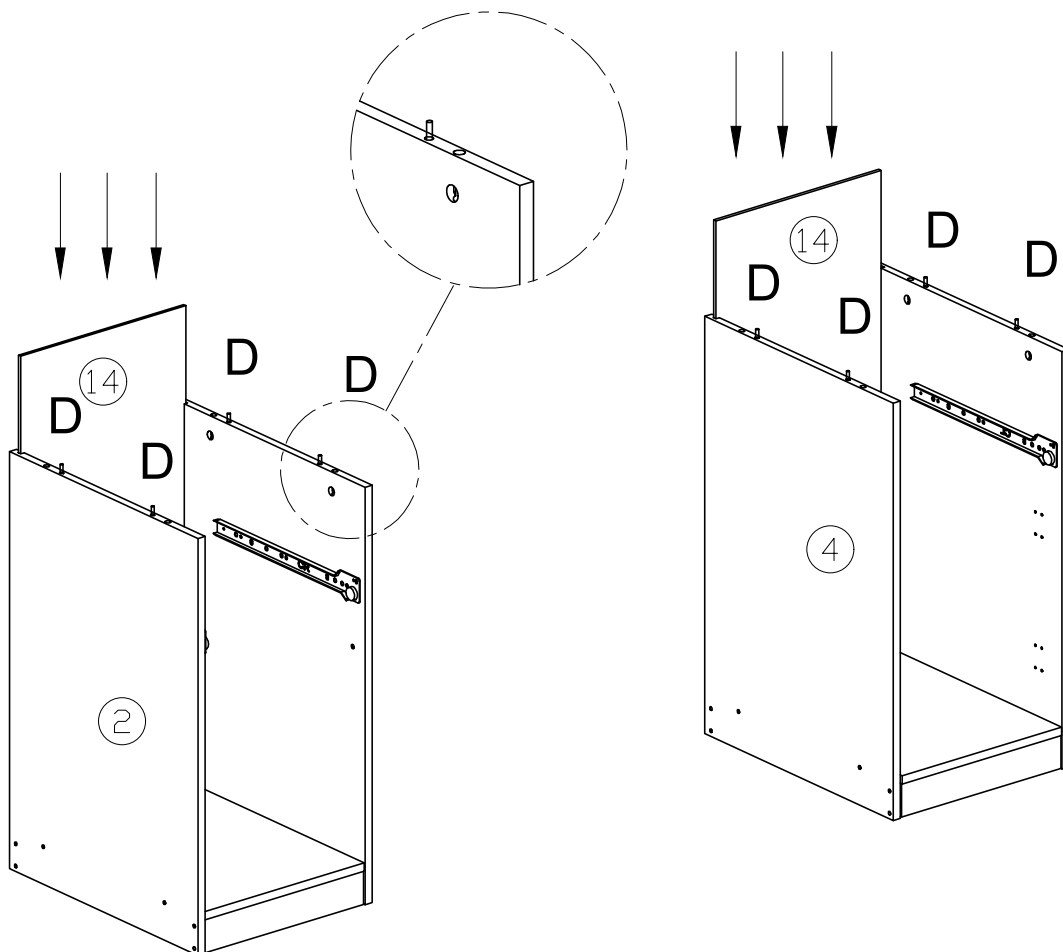

D		8
---	---	---

12

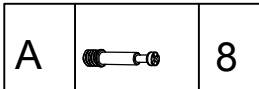
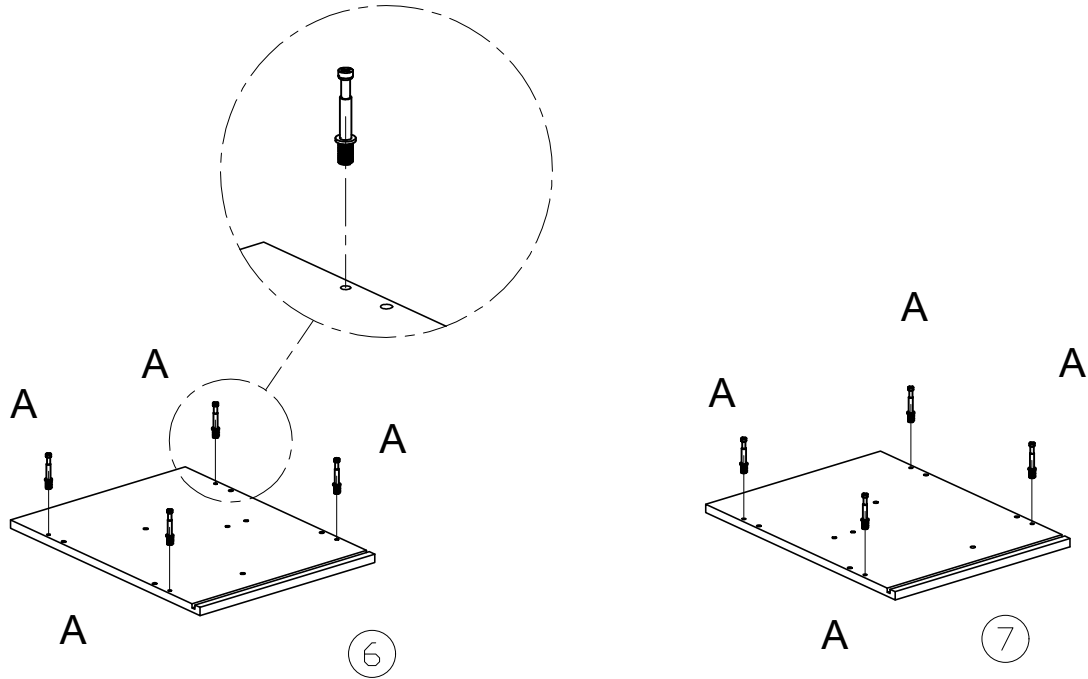

13

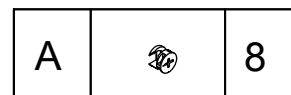
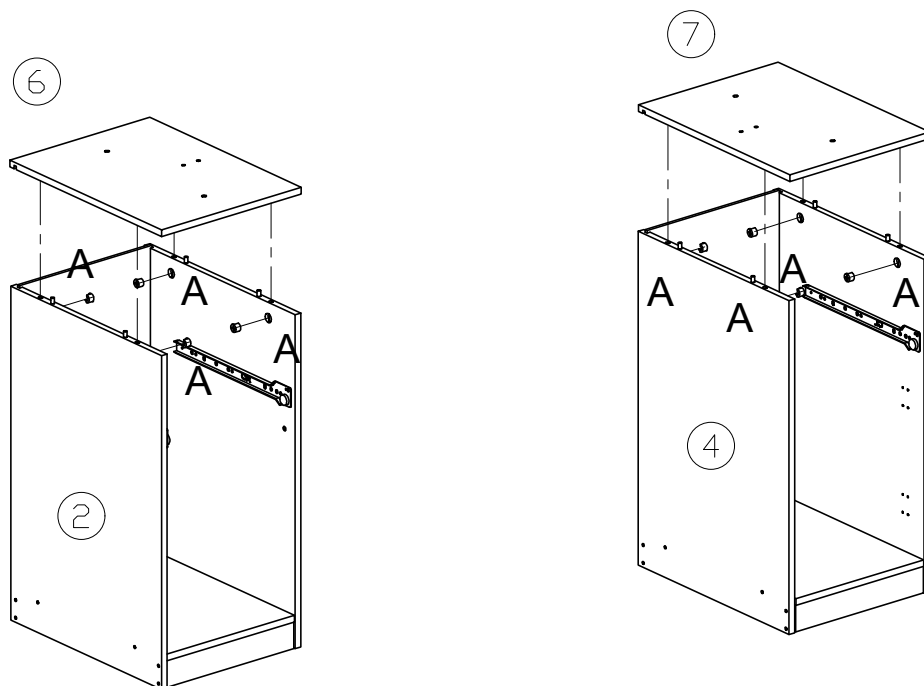

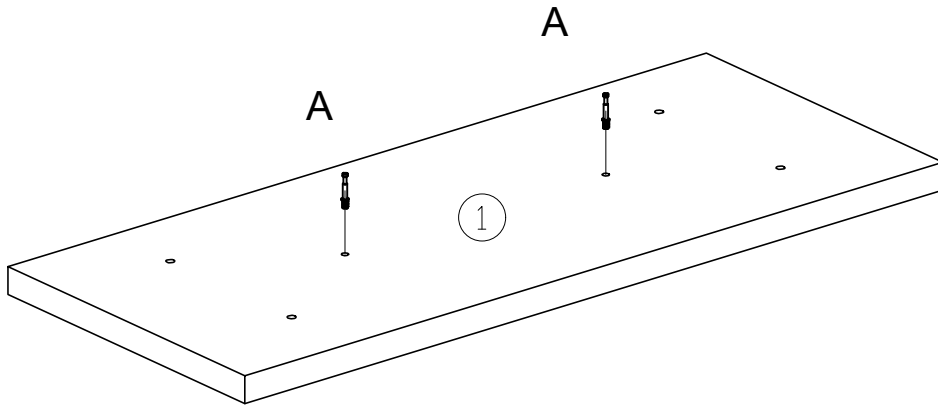

14



A		2
---	---	---

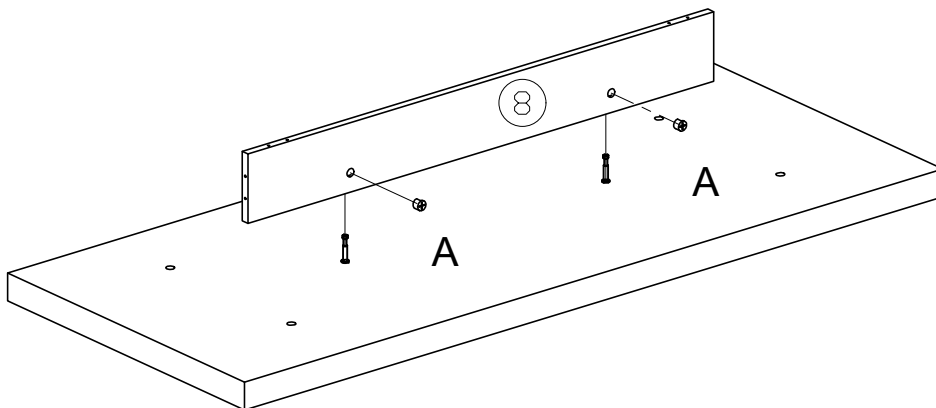

15



A		2
---	---	---

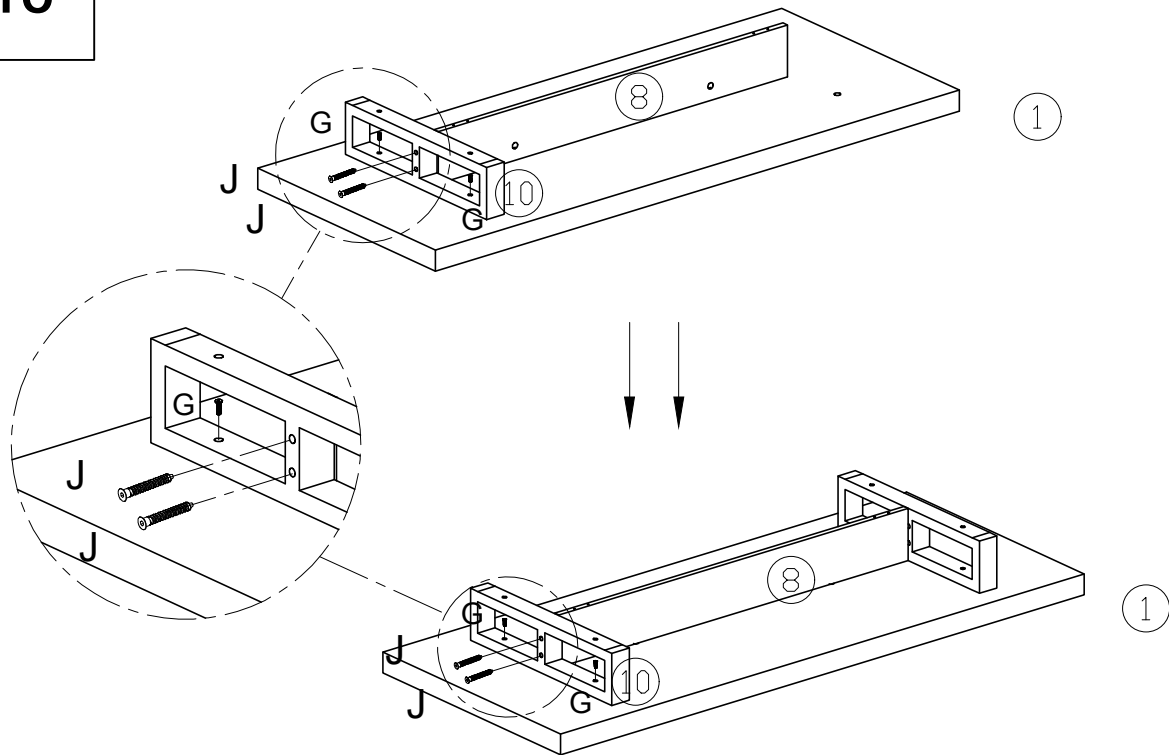

16

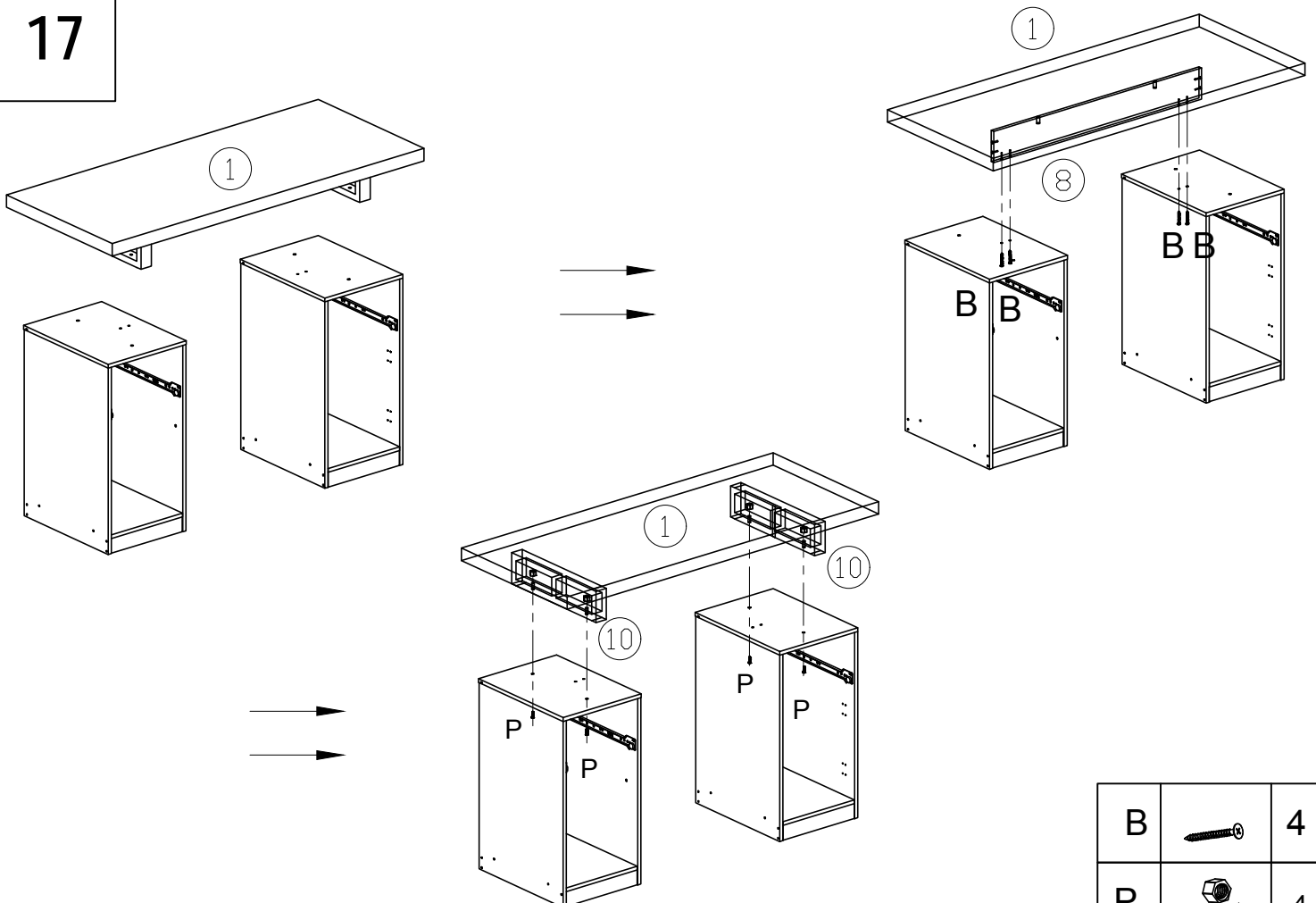

J		4
G		4

17



B		4
P		4

Schematic diagram of regulating cabinet door

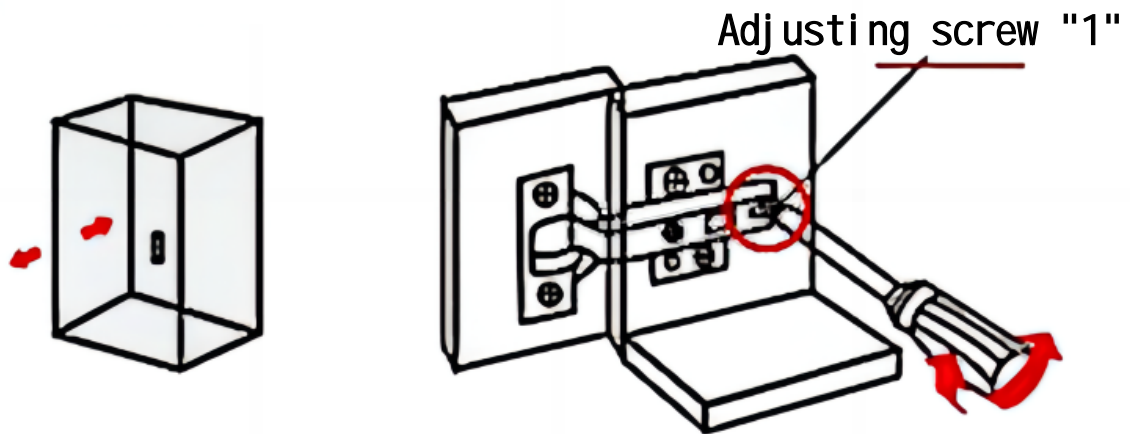

Front and rear adjustment of cabinet door:

Adjusting screw "1" can change the gap between the door panel and the cabinet body

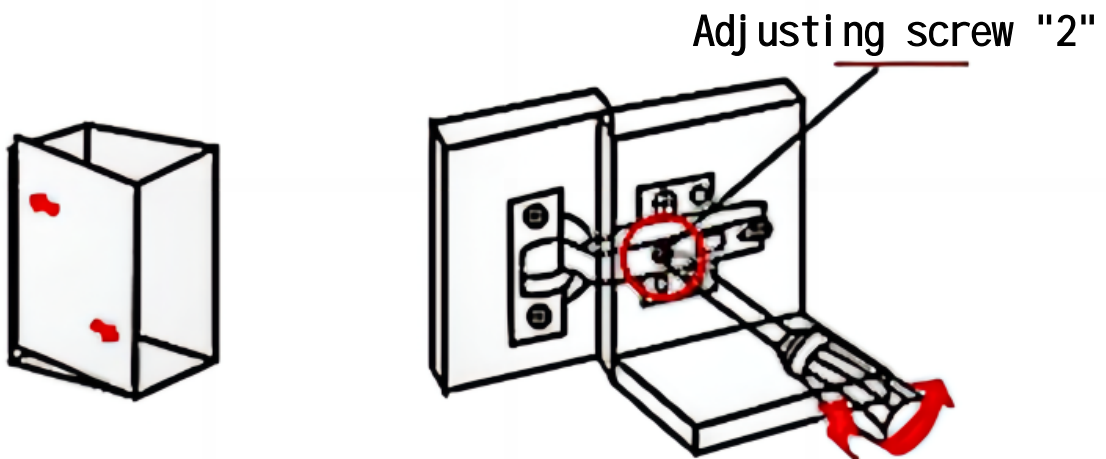

Cabinet door left and right adjustment:

Adjusting screw "2" can change the coverage of the door panel relative to the side panel of the cabinet

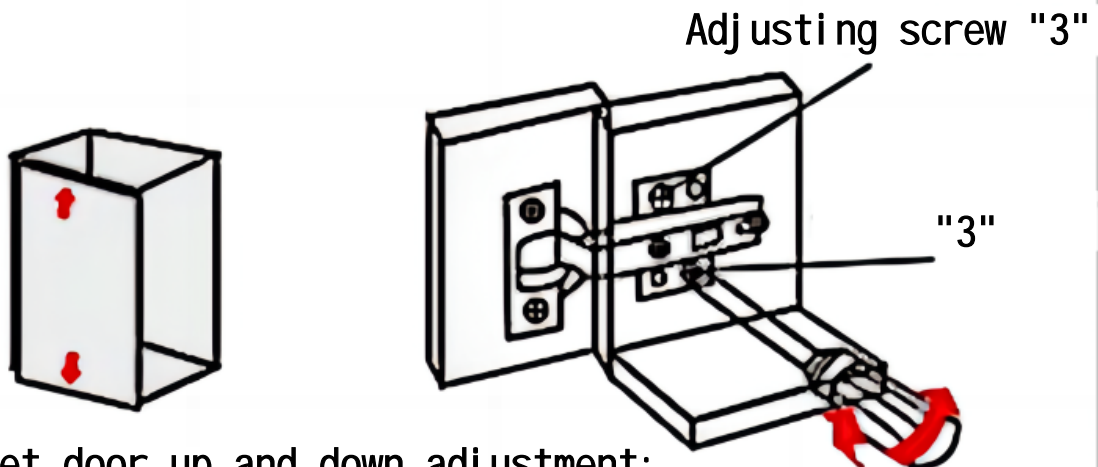

Cabinet door up and down adjustment:

Adjusting screw "3" can correct the upper and lower gaps of the door panel

18

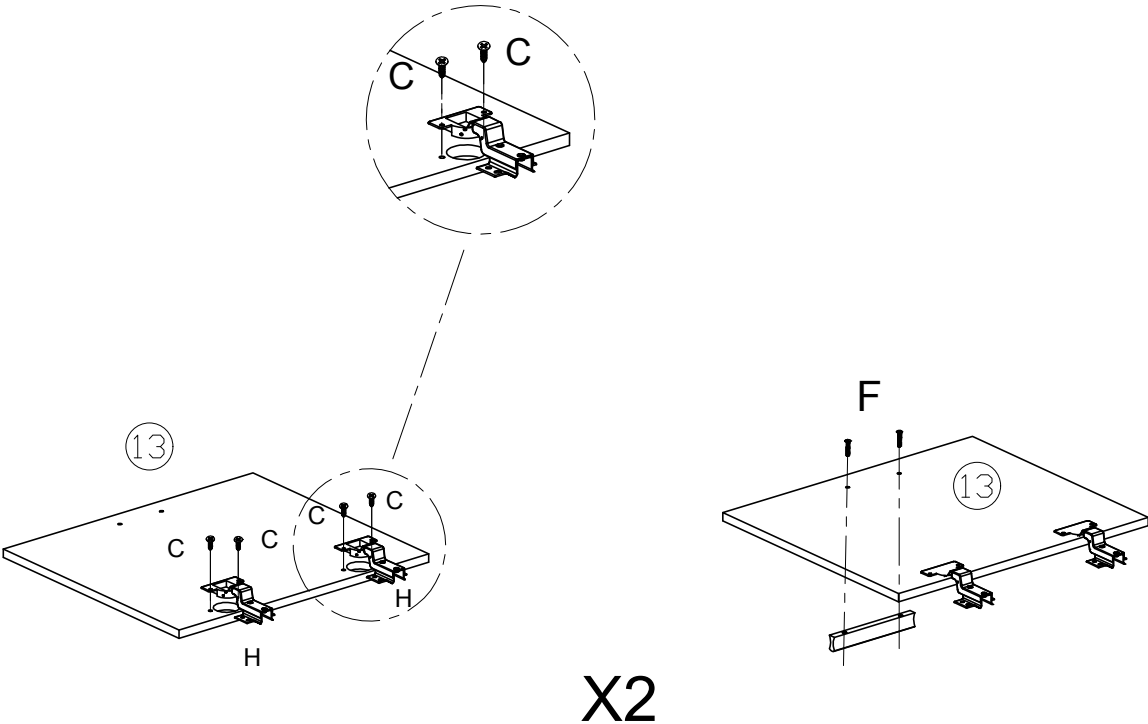

H		4
E		2
F		4
C		8

19

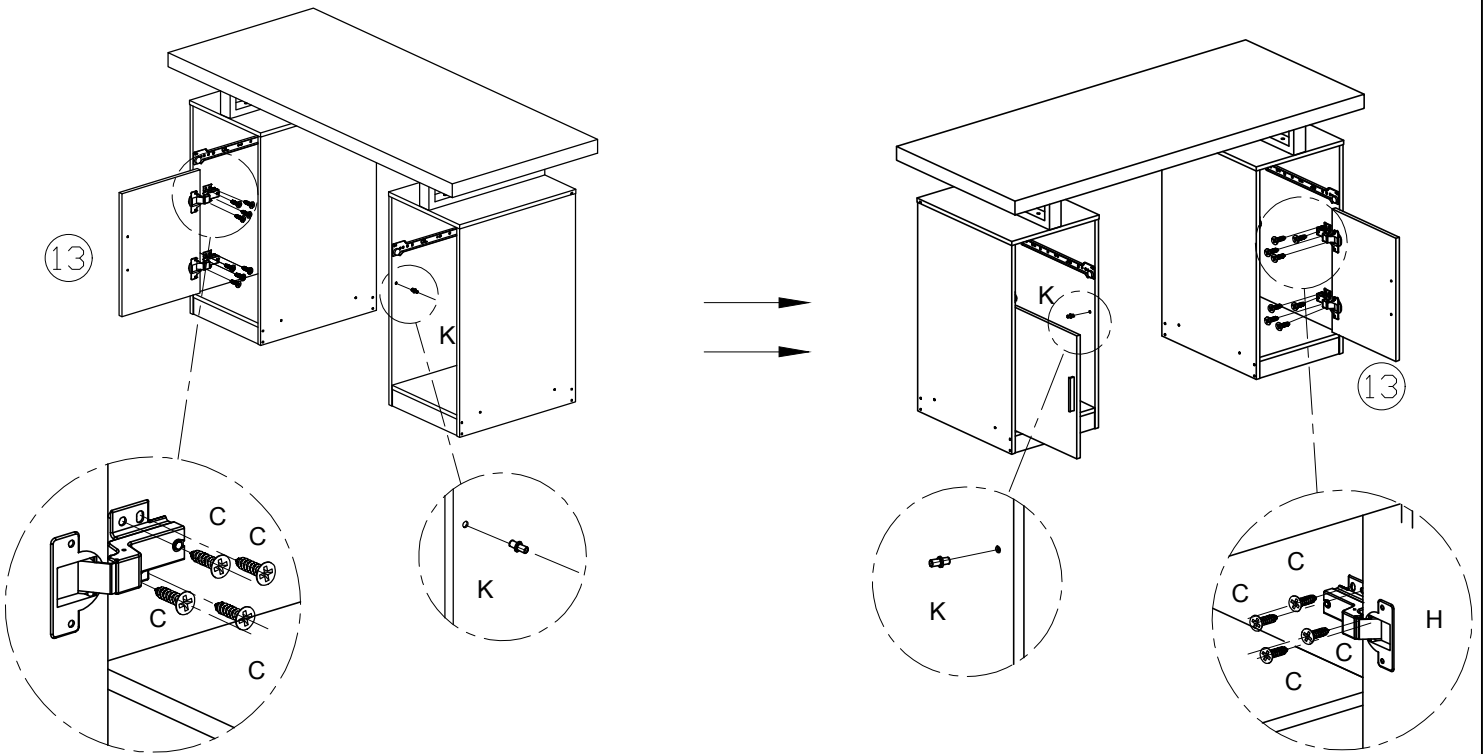

K		2
C		16

20

