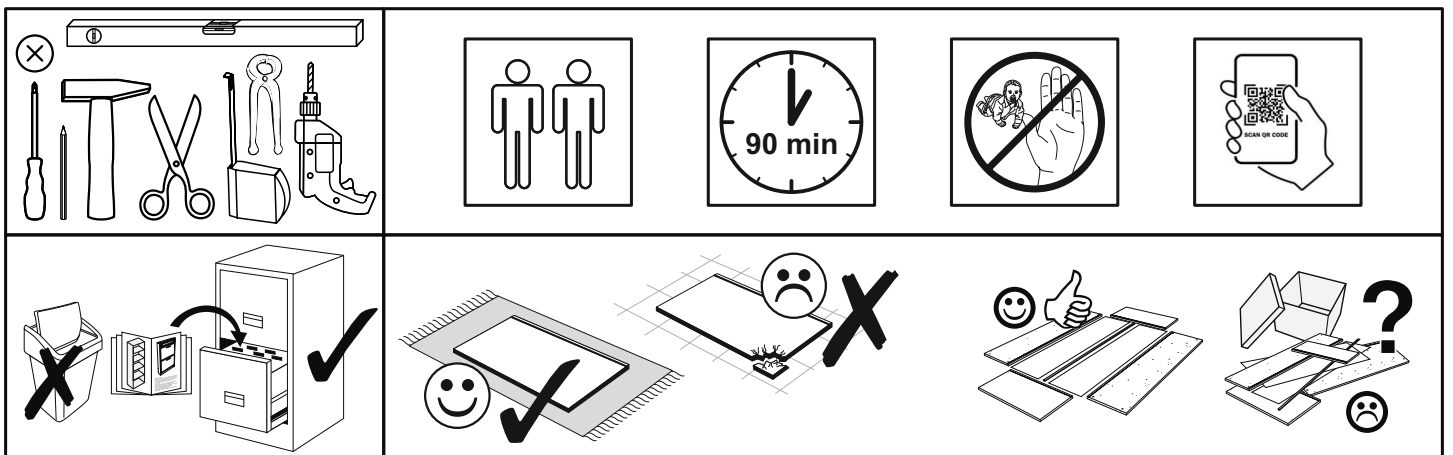

Artikel.-Nr.:

**0811-KO\_23**

Montageanleitung.-Nr.:

**MA1-00454**

SCAN ME

Das Ersatzteil-Anforderungsformular finden Sie auf  
 The replacement parts requisition form you find on  
<https://www.maeusbacher.de/ersatzteile/>

### BT1-00230 Colli 1/2

B03-43		B03-11		B03-07	
4x		4x		2x	

### BT1-00549 Colli 1/2

B05-185		B06-535		B05-20	
4x		5x		16x	ø20mm

### BT1-00005 Colli 1/2

B02-173		B01-123		
4x		8x		4,0x15

### BT1-00548 Colli 1/2

B02-10		B02-20		B02-65	
36x	ø15x12mm	20x		8x	
B01-10		B02-103		B05-20	
4x	6,3x50	24x	8x30	4x	ø20mm
B02-160		B01-200		B01-30	
4x		12x	6,3x13	42x	3x16
B01-80		B01-90		B01-122	
8x	3,5x13	4x	3,5x20	6x	4,0x13
B01-327		B08-80			
10x	M4x19	1x			

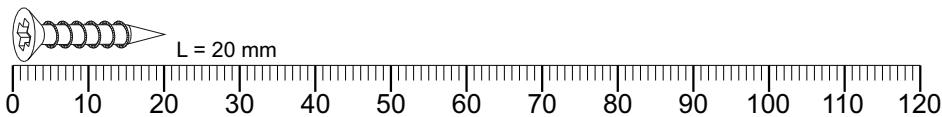

SCAN ME

### Colli 1/2

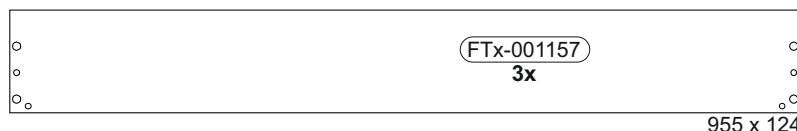
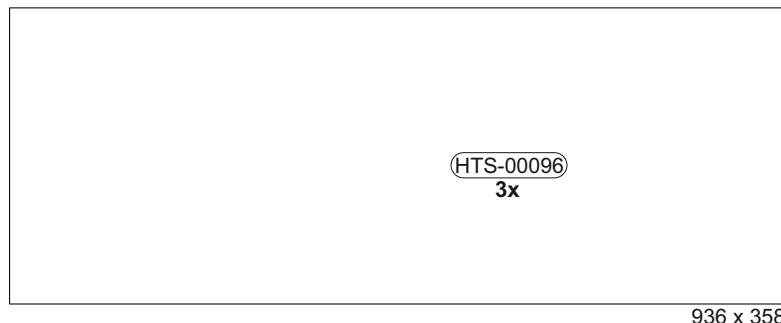
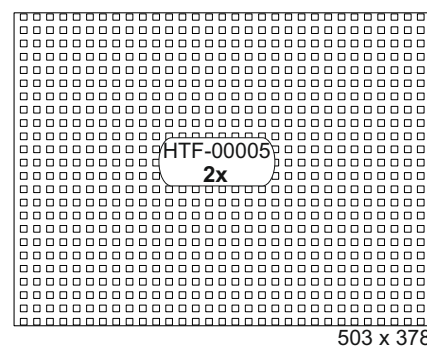
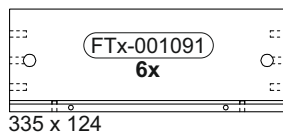
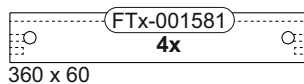
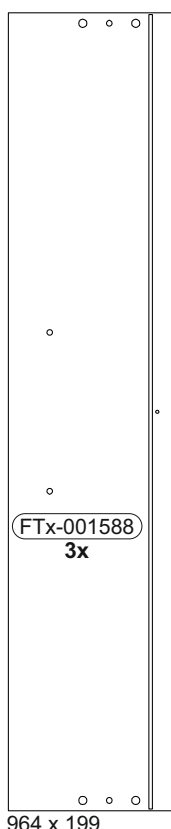
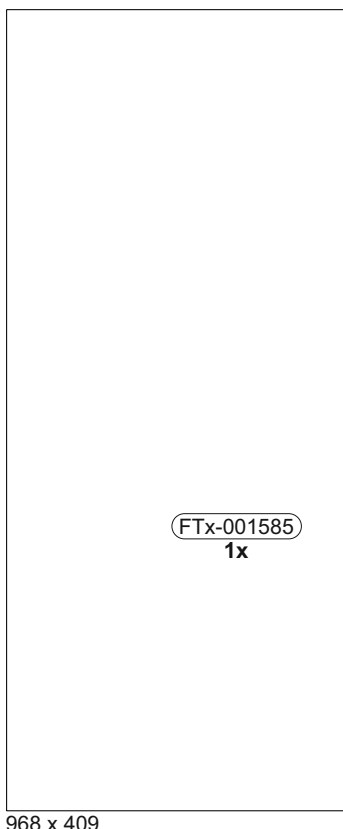
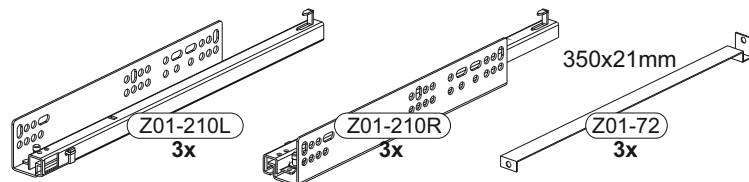
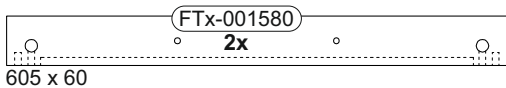
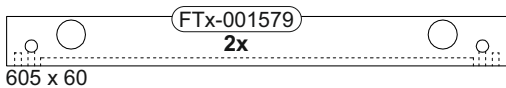

# Colli 2/2

Z02-500  
3x

500 x 50

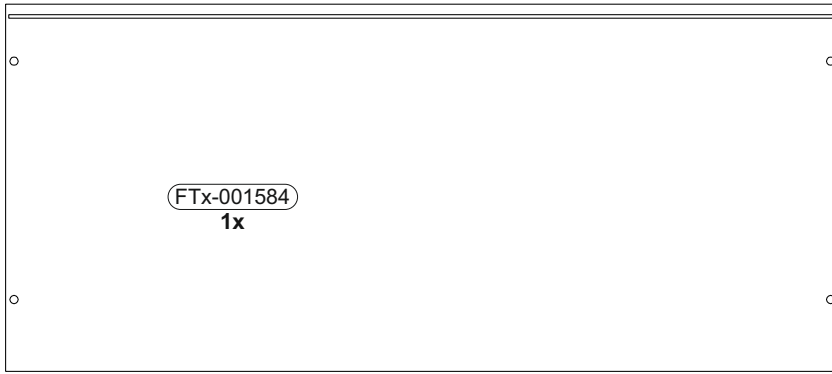

1007 x 444

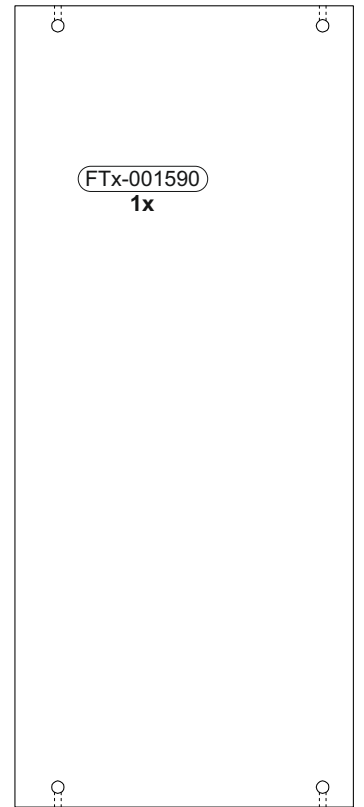

968 x 409

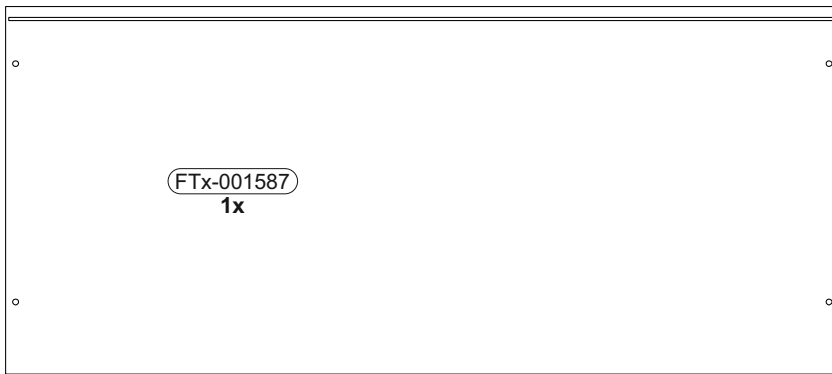

1007 x 444

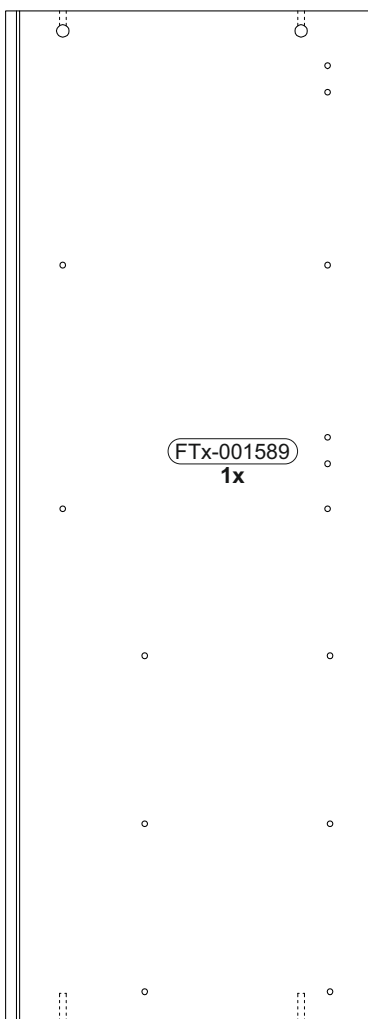

1007 x 444

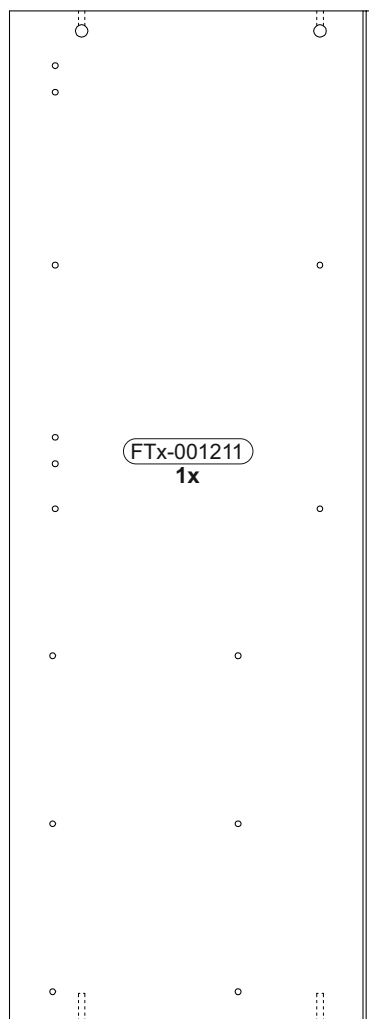

1007 x 444

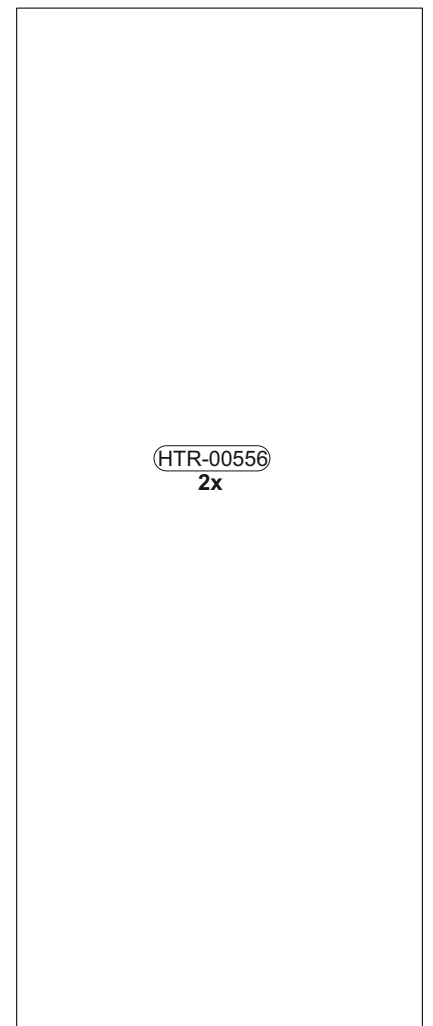

1234 x 490

1

	B02-10		B02-20		B02-103		B01-122		B01-30	
	12x	ø15x12mm	12x	24x	8x30	6x	4,0x13	27x	3x16	
							B06-535		B01-327	
							3x	6x	M4x19	

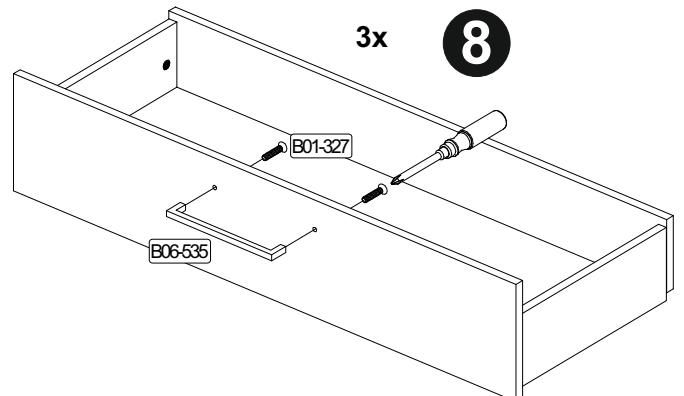
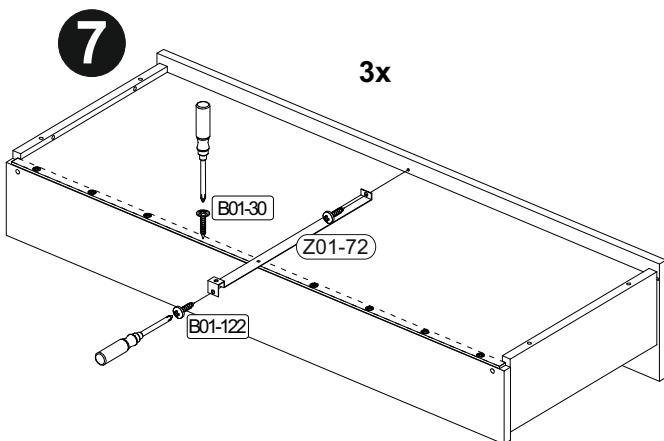
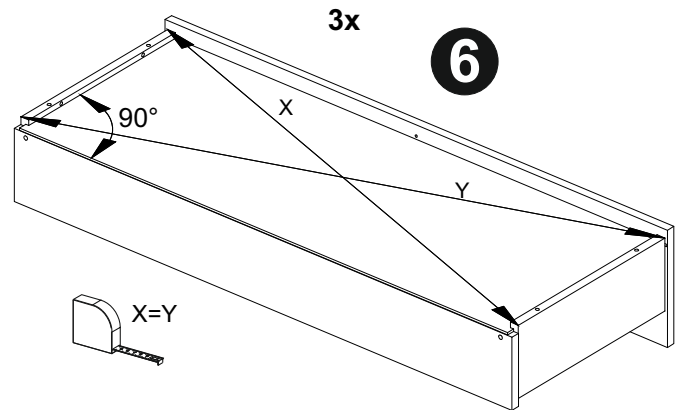
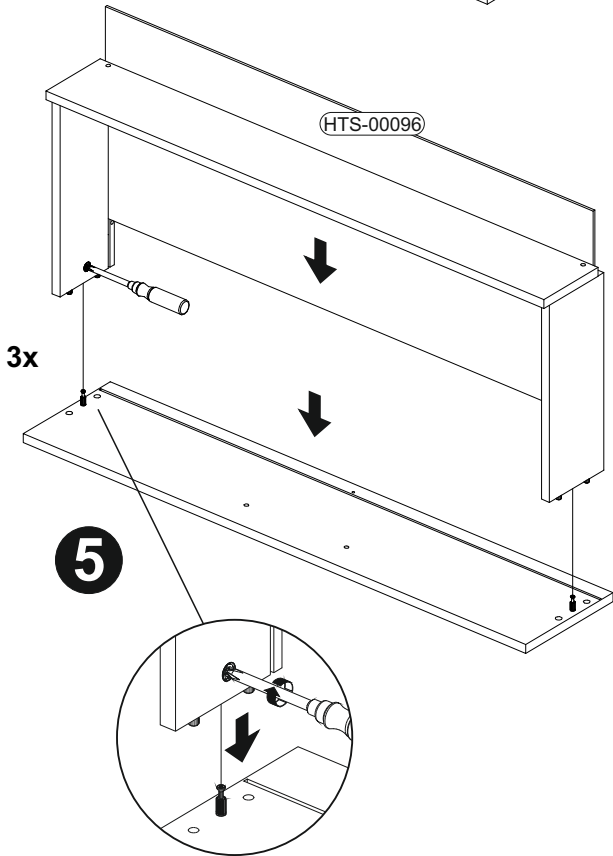
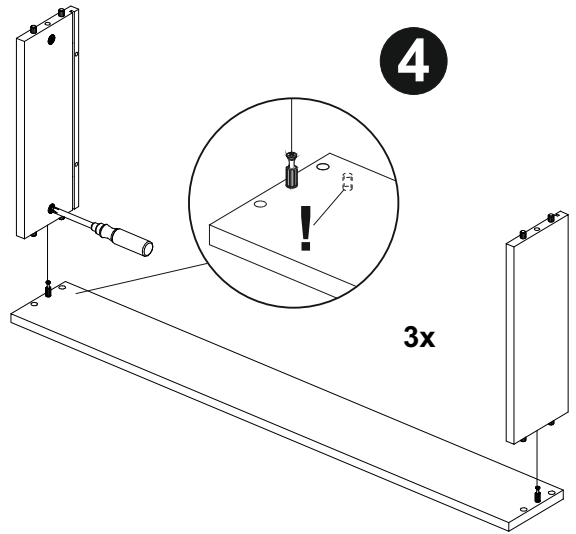
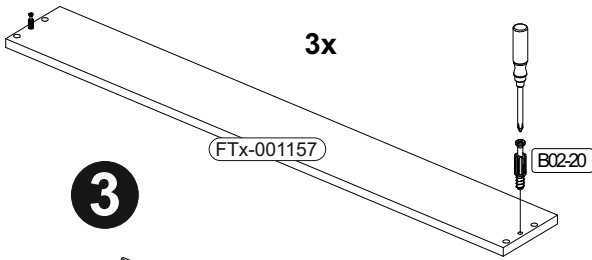
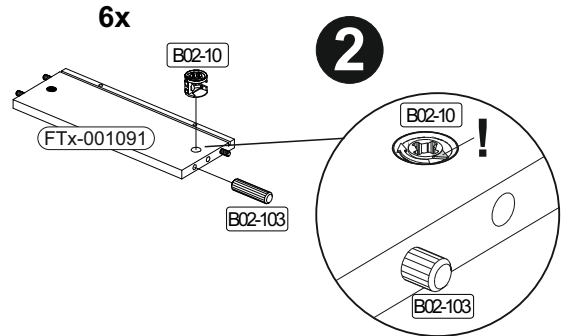
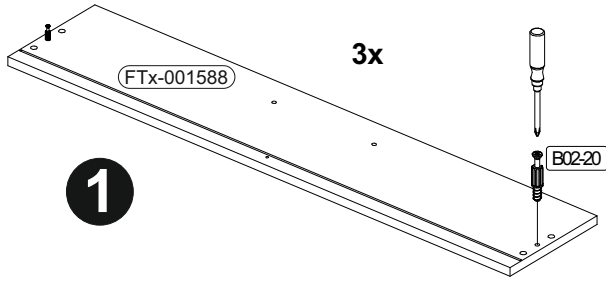

2

	4x	4x	4x	12x	4x					
	ø15x12mm									

1

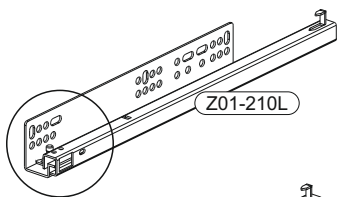

Z01-210L

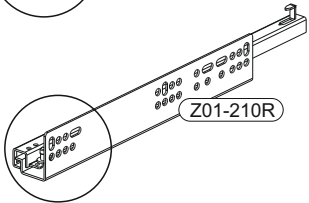

Z01-210R

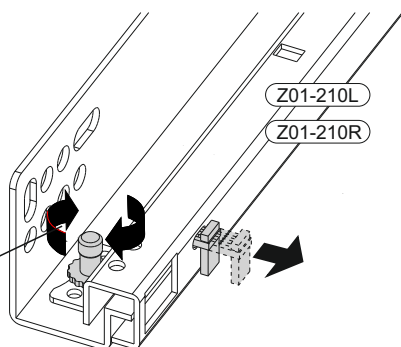
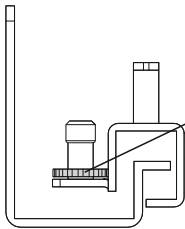
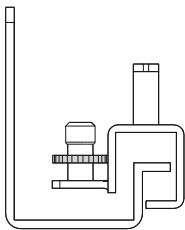

Z01-210L

Z01-210R

2

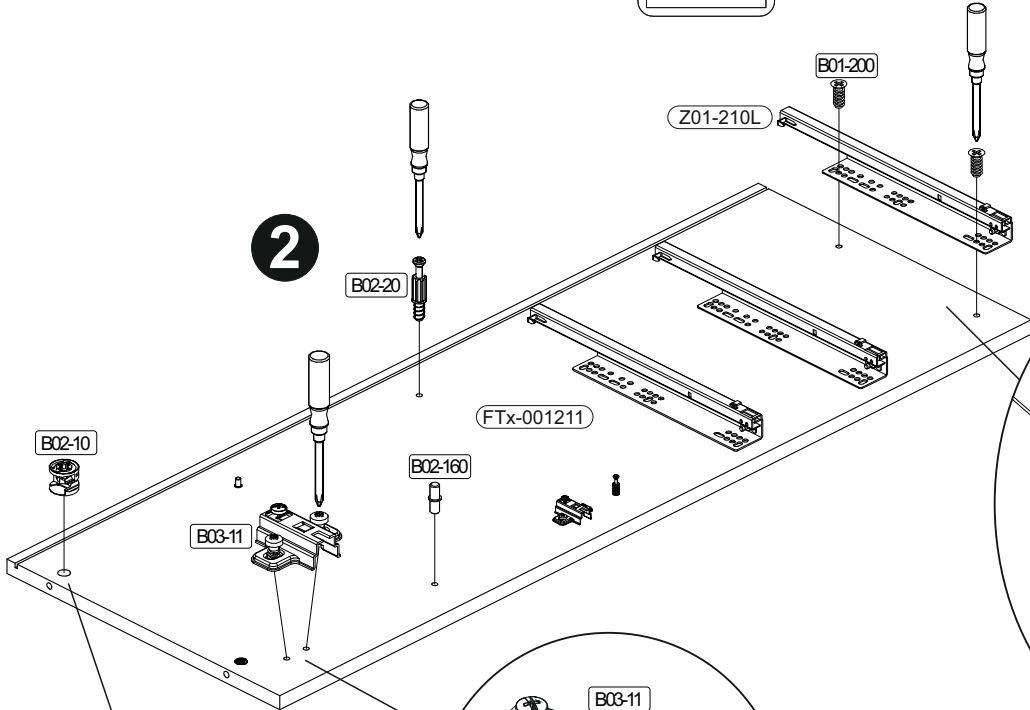

B02-10

B02-20

B01-200

Z01-210L

FTx-001211

B02-160

B03-11

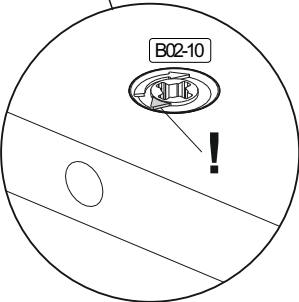

B02-10

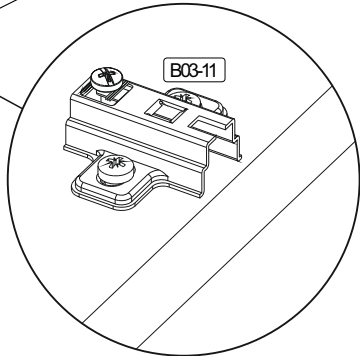

B03-11

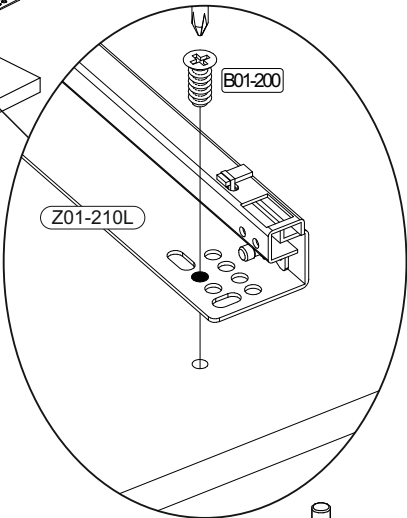

B01-200

Z01-210L

3

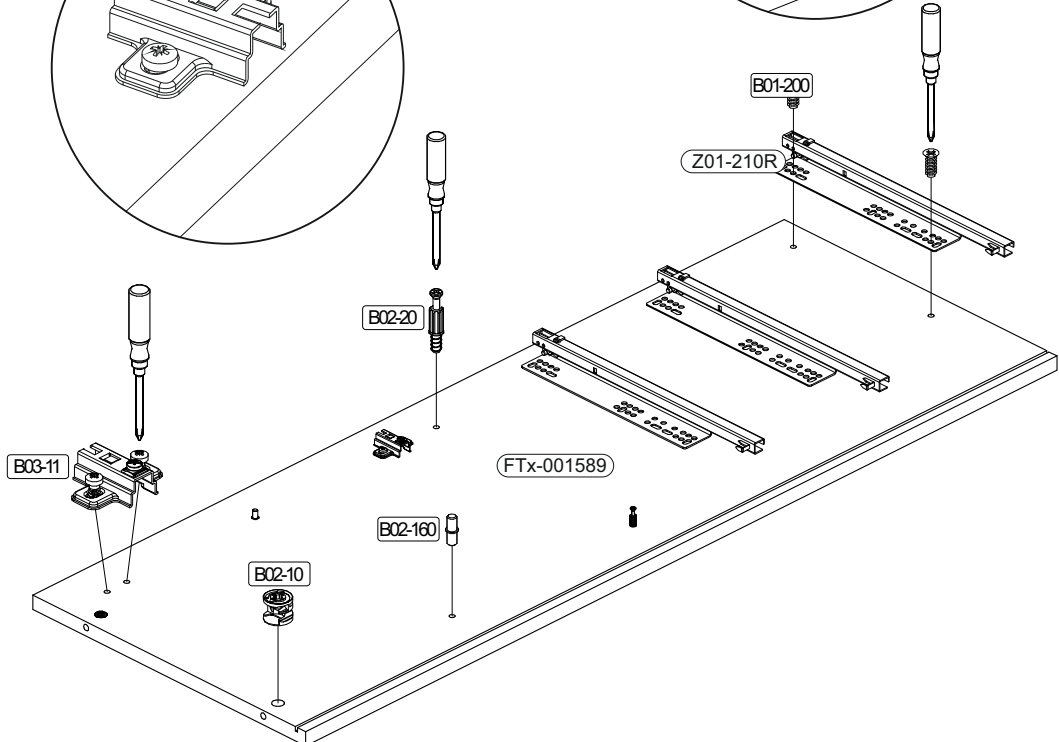

B02-20

B01-200

Z01-210R

FTx-001589

B02-160

B02-10

B03-11

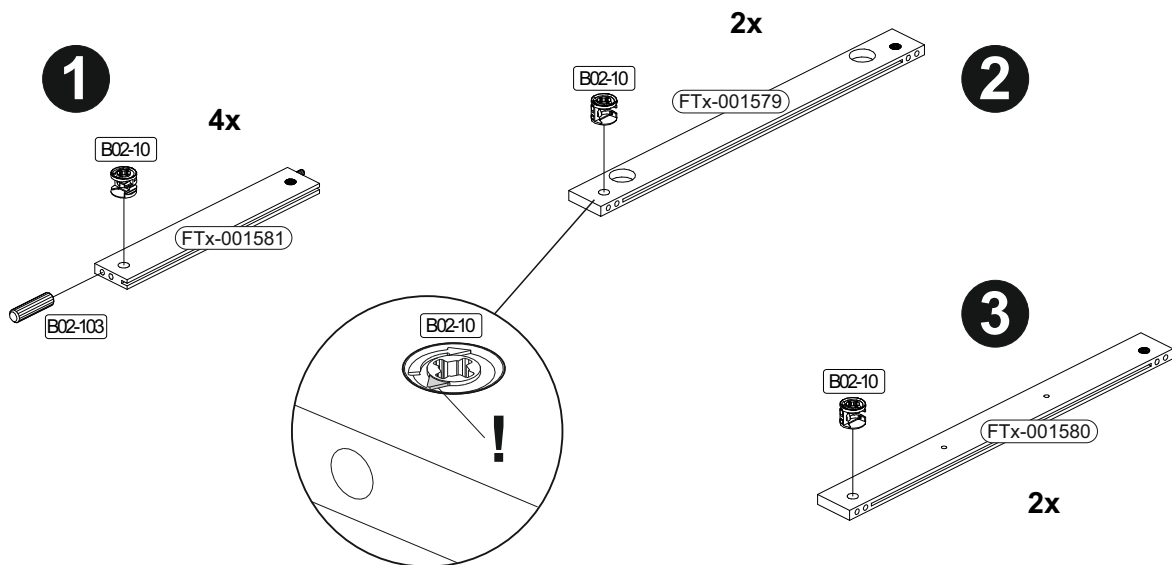
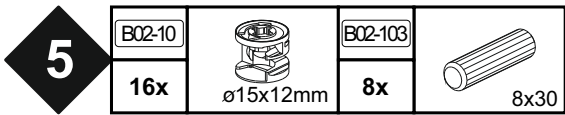
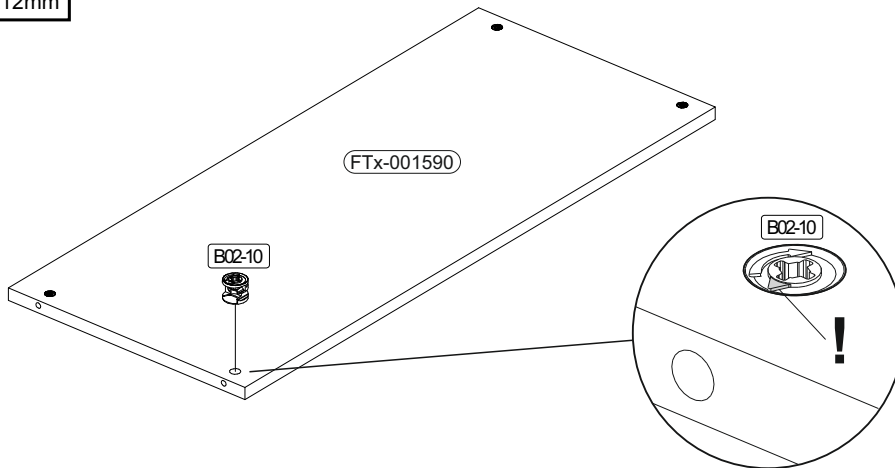
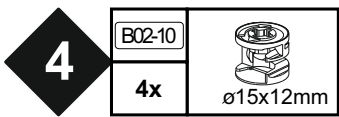
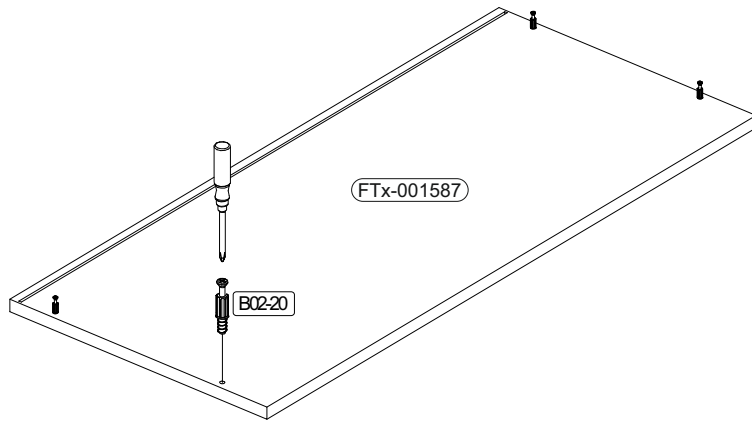
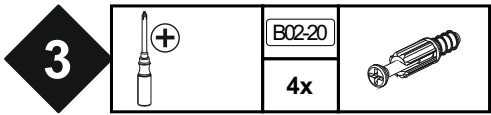

6

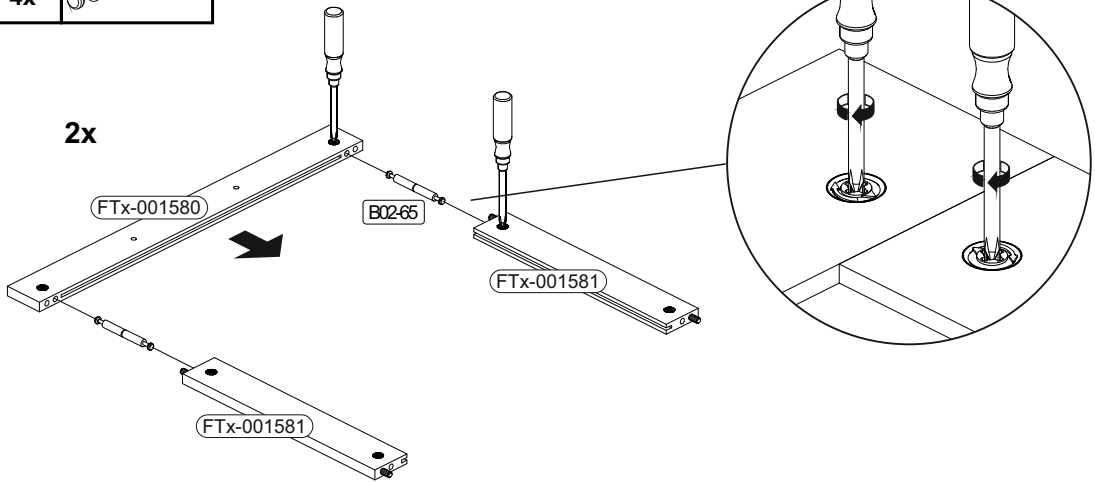
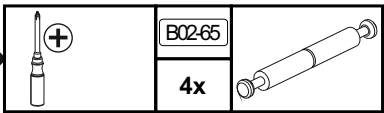

7

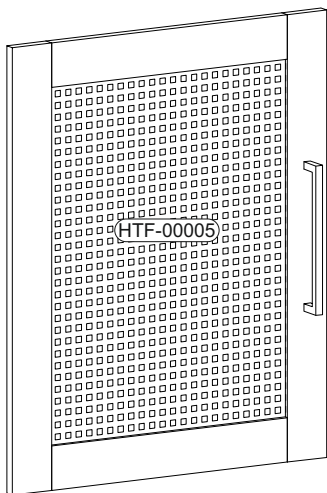
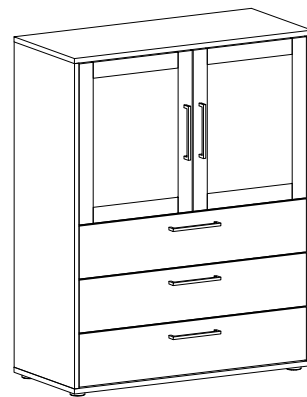
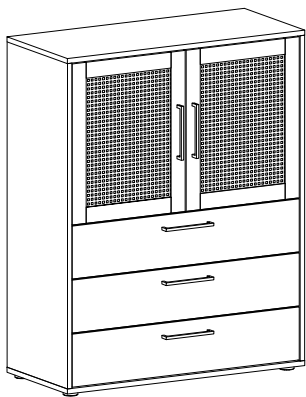

???

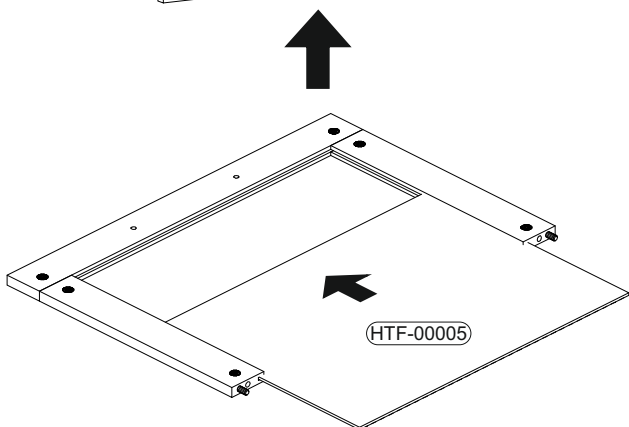
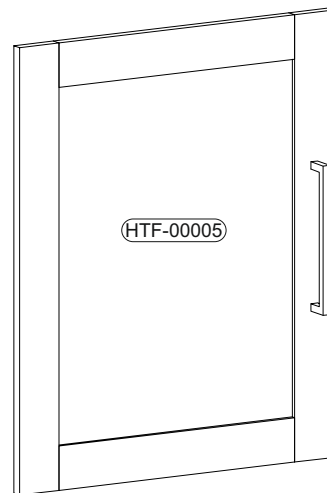

2x

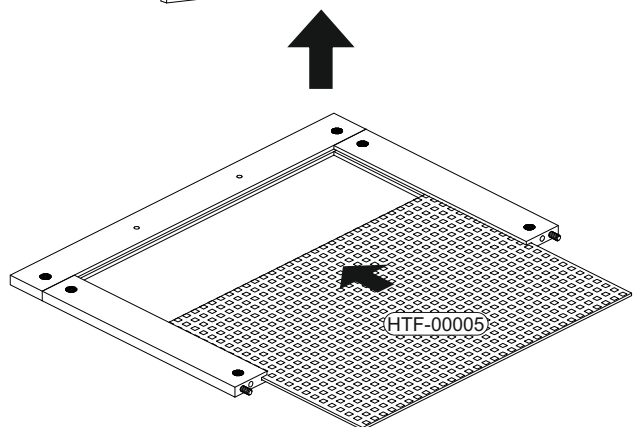

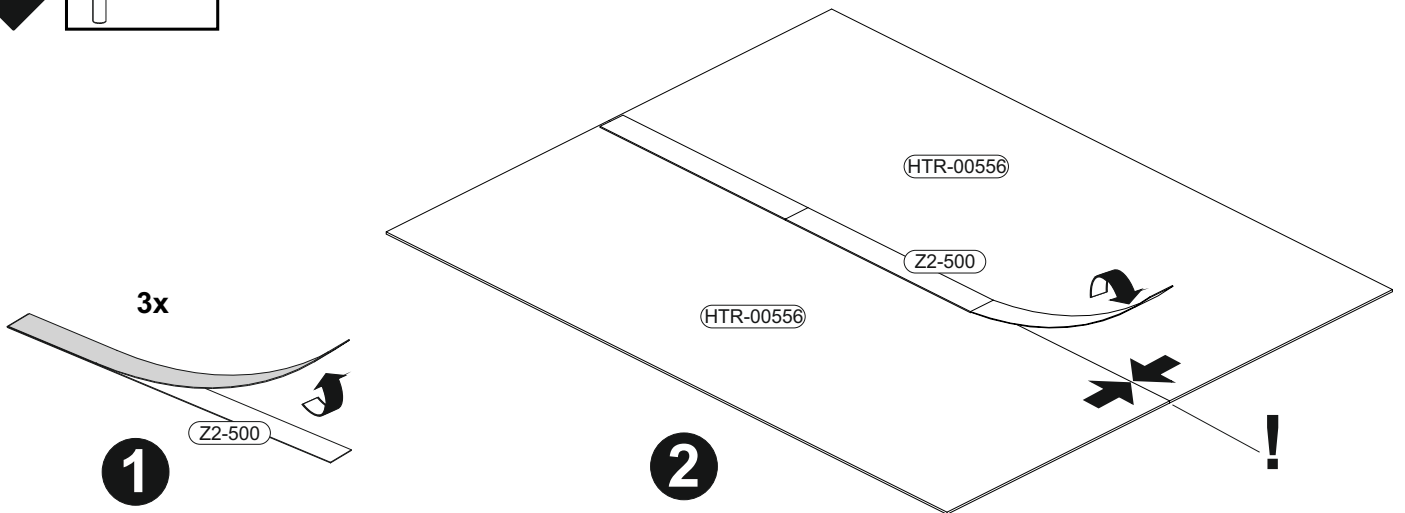
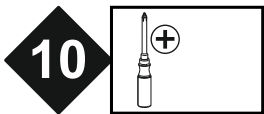
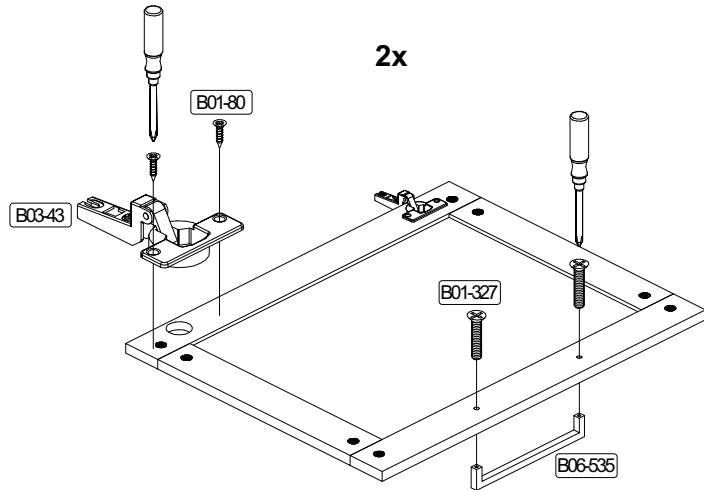
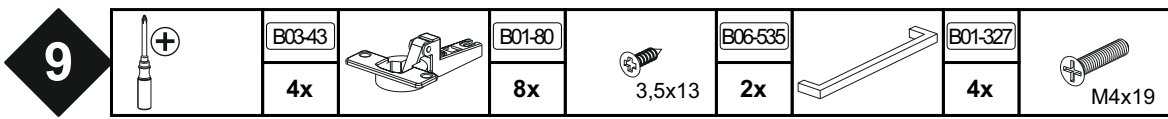
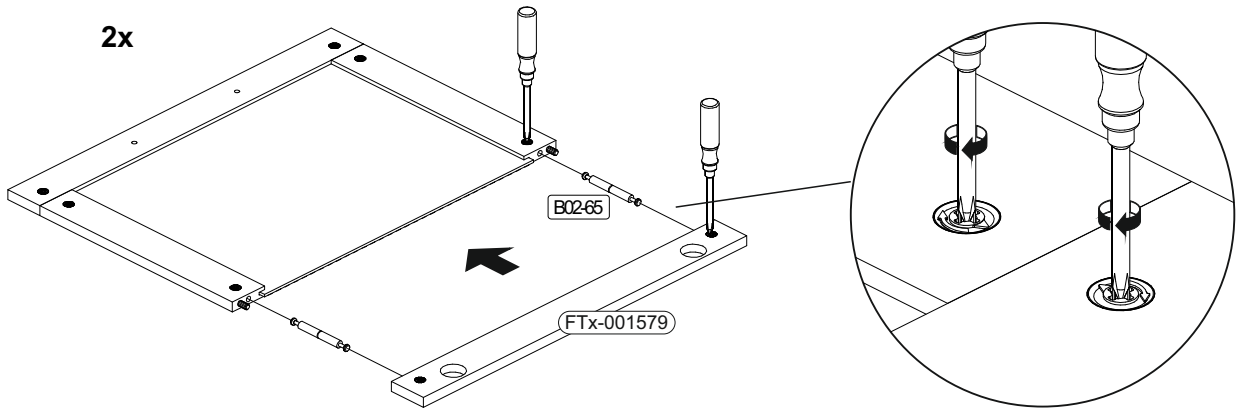
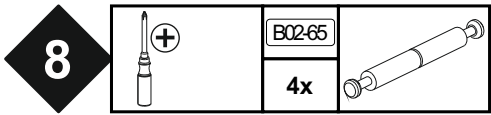



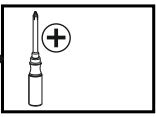

**11** 

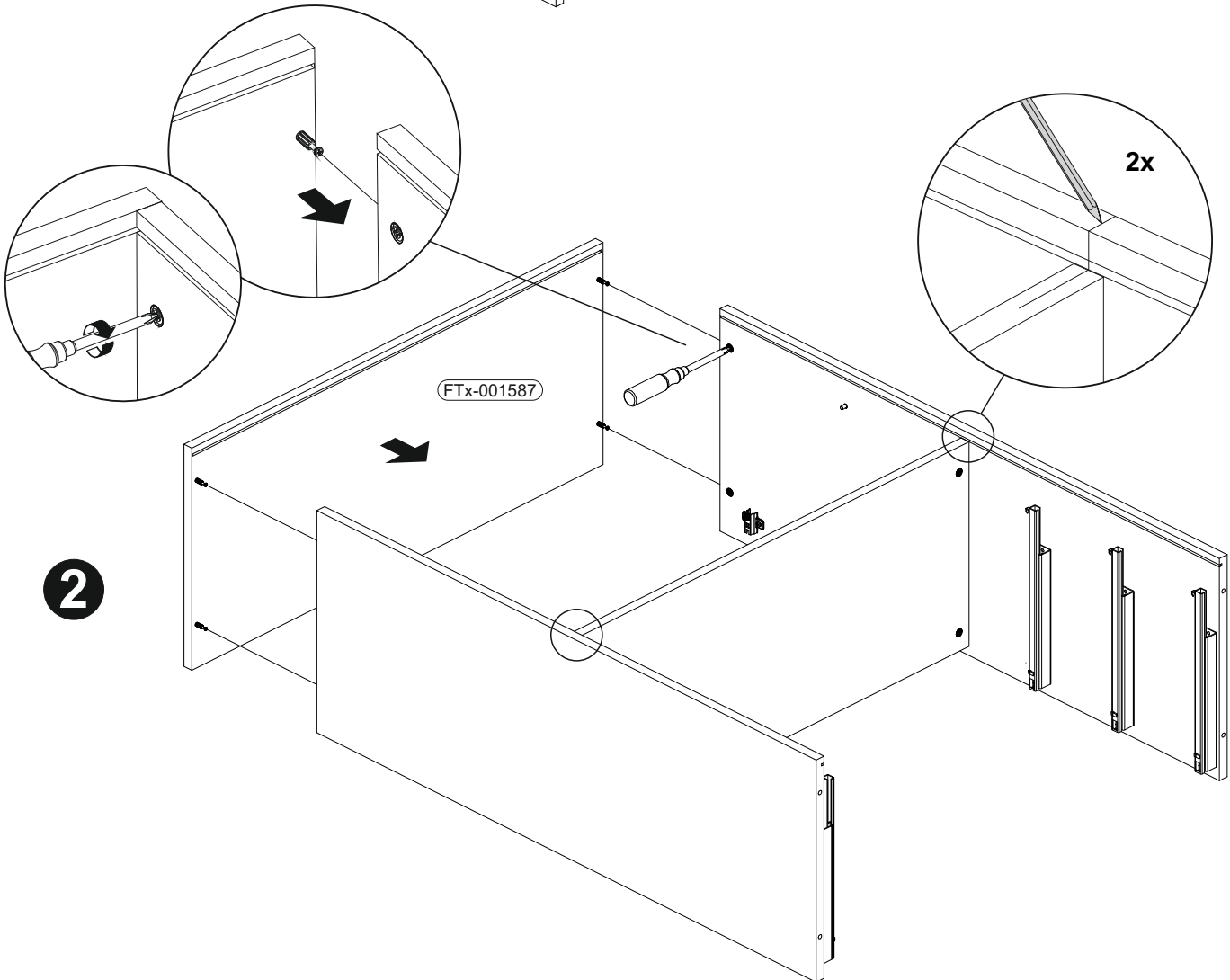
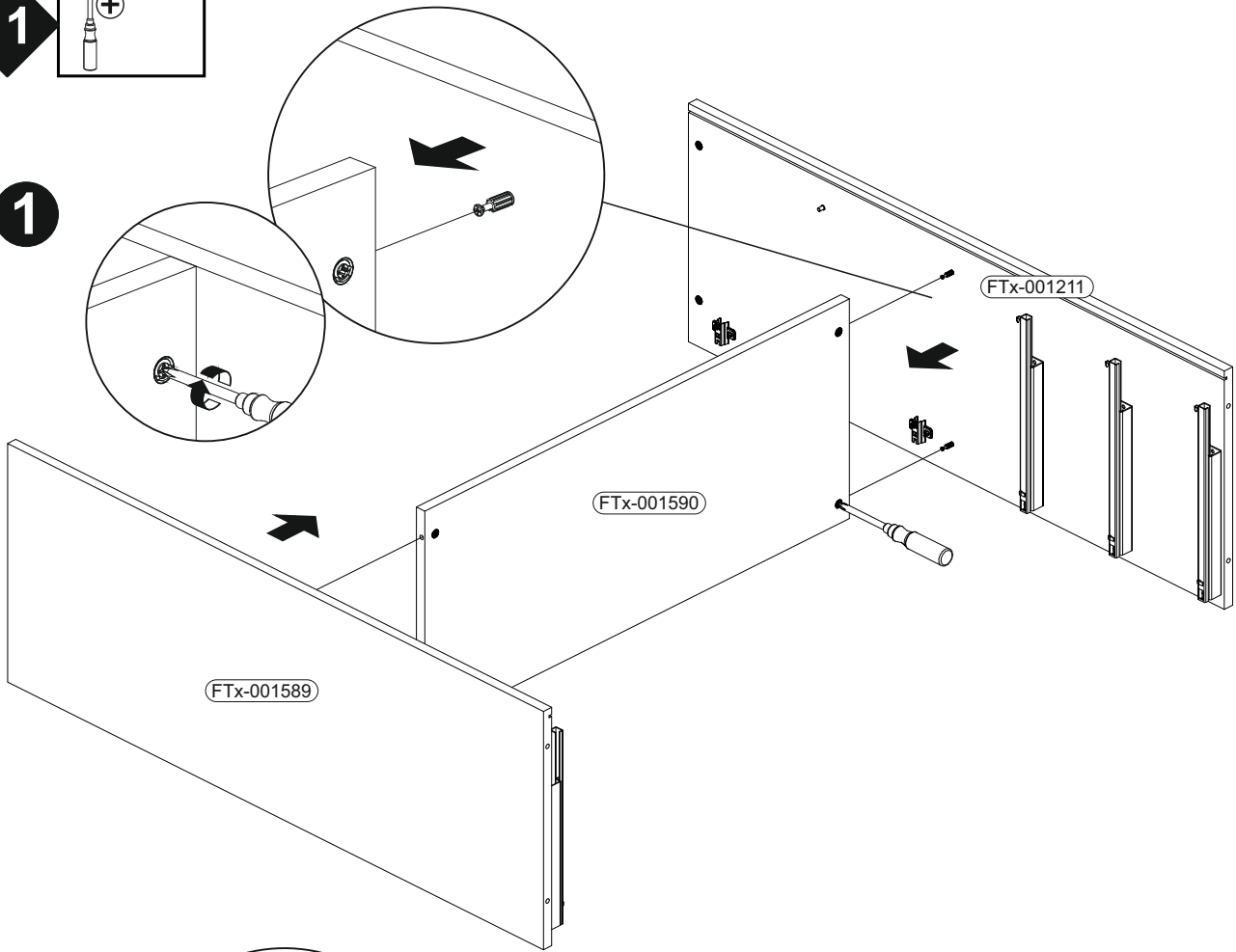
**1**







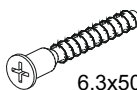

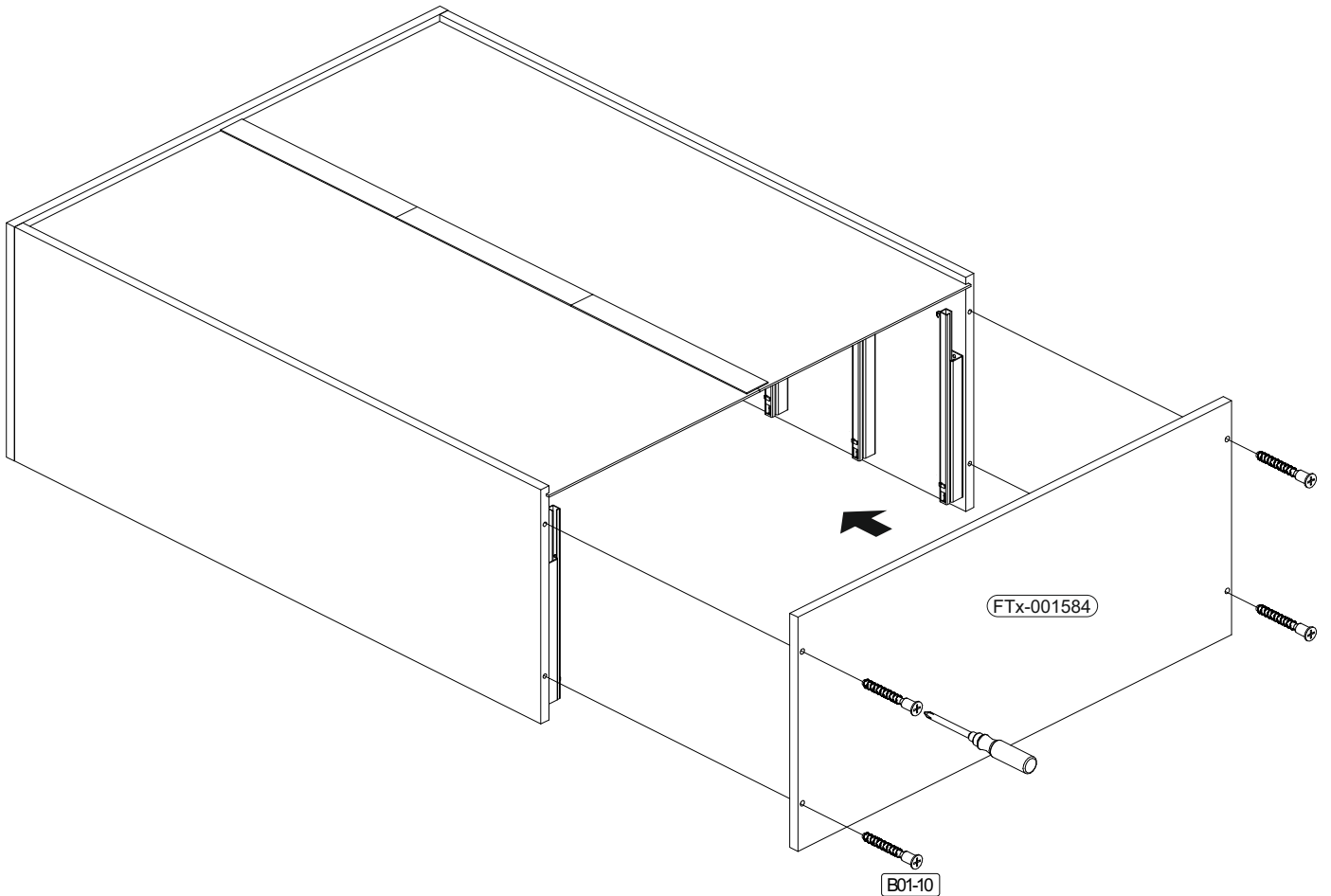
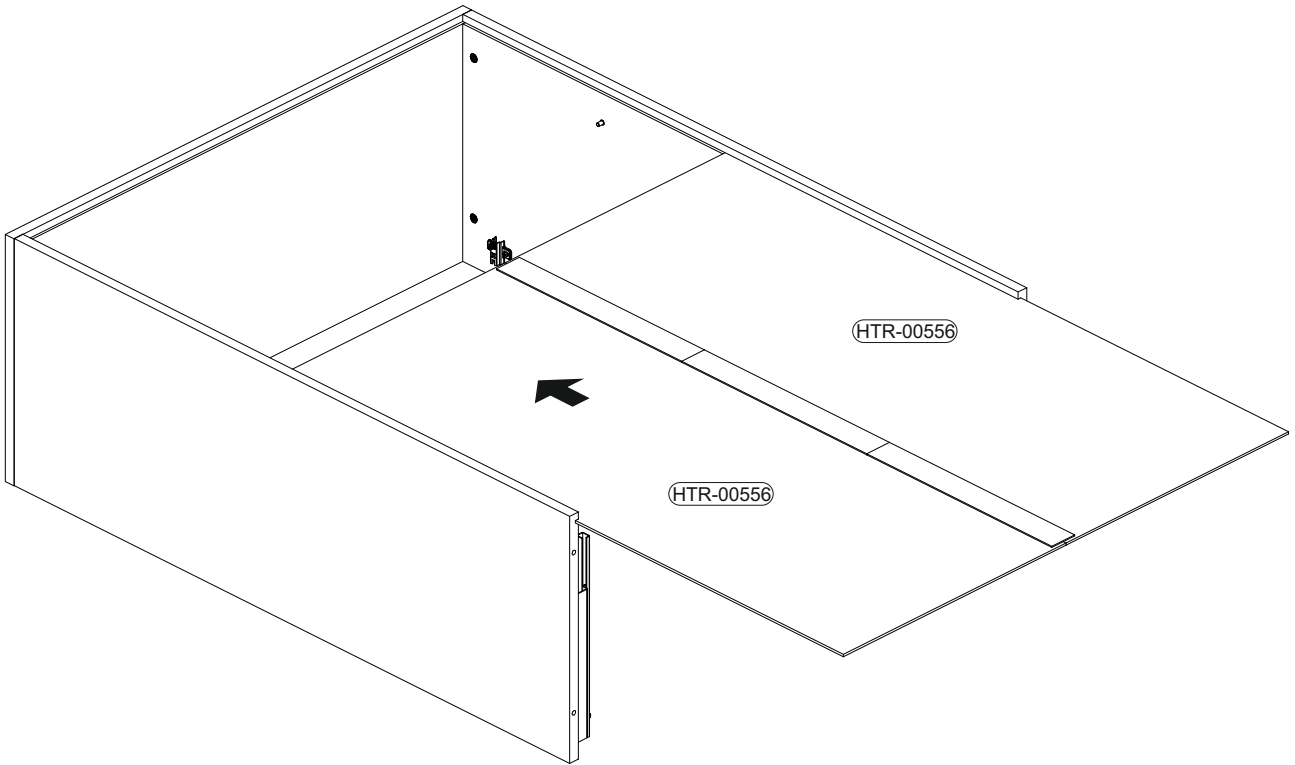
**2**

12

		B01-10	
4x			6,3x50



13

	<b>B01-90</b>		<b>B05-185</b>		<b>B01-30</b>		<b>B02-173</b>		<b>B01-123</b>	
	4x	3,5x20	4x		15x	3x16	4x		8x	4,0x15

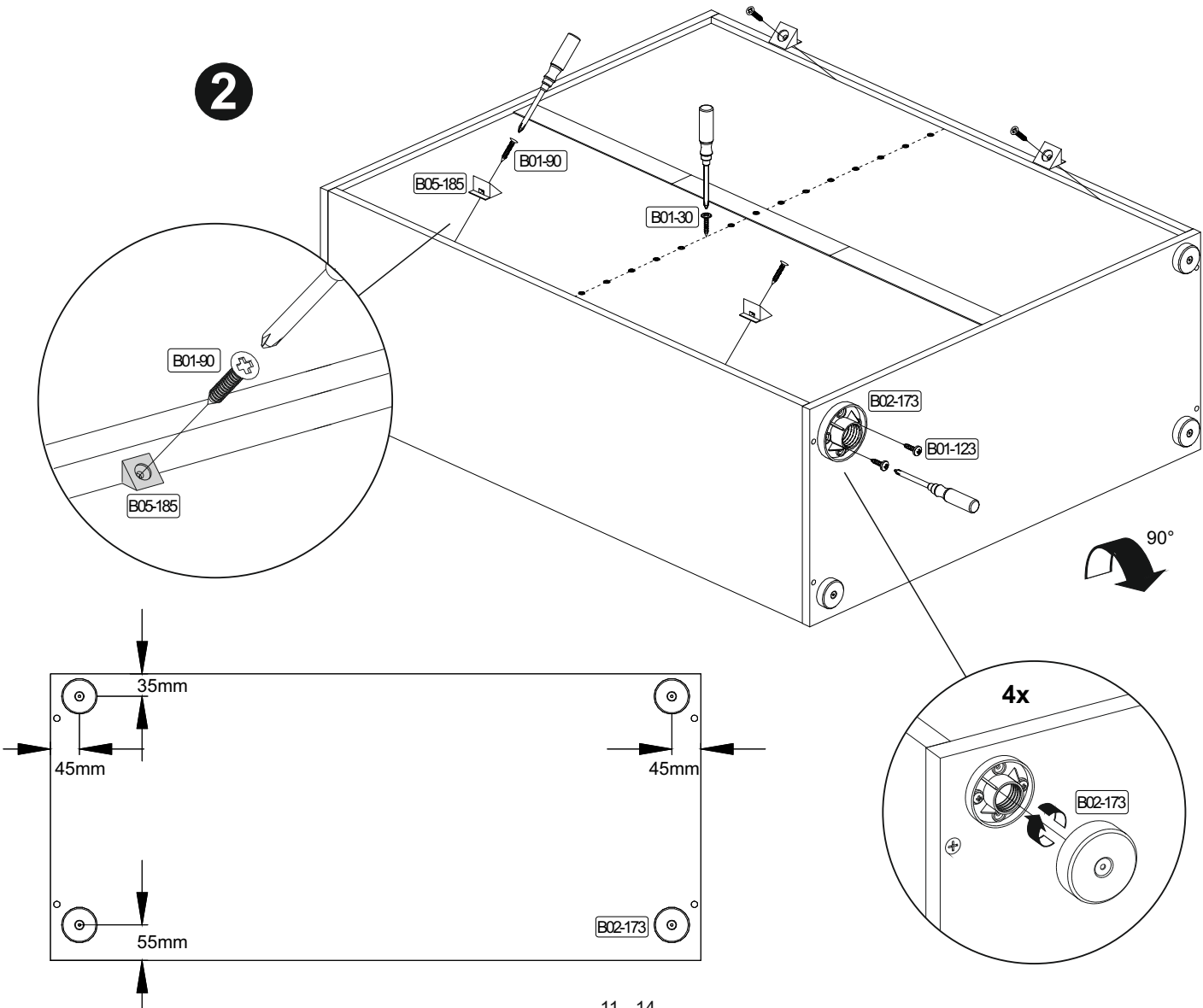
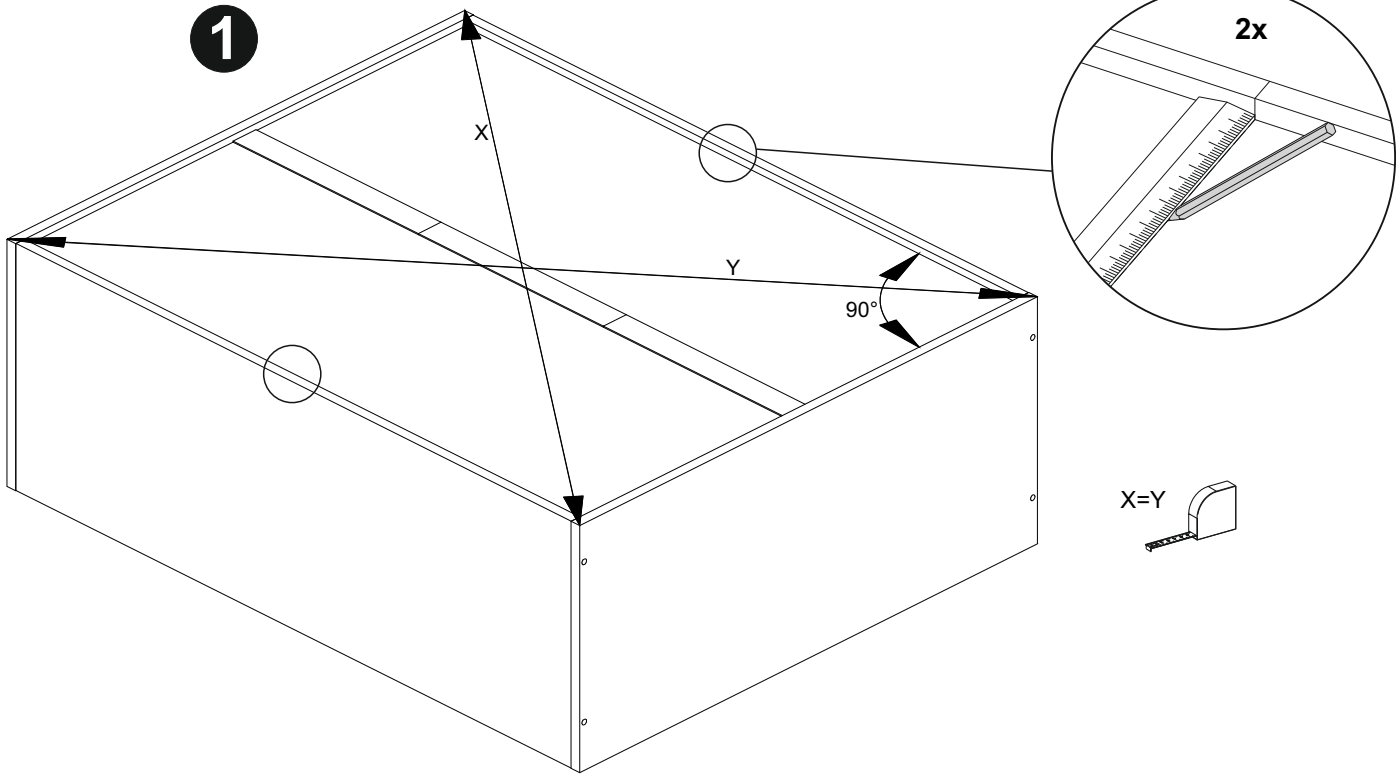

14

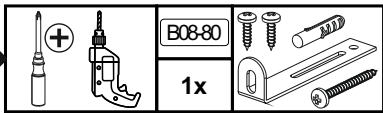

1

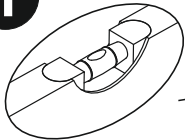

SCAN ME

2

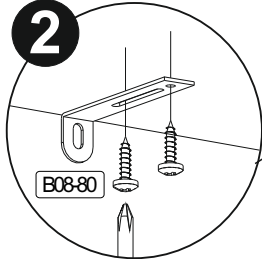

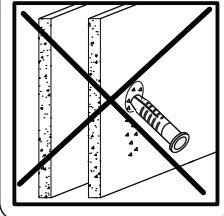
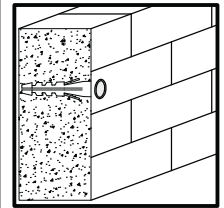
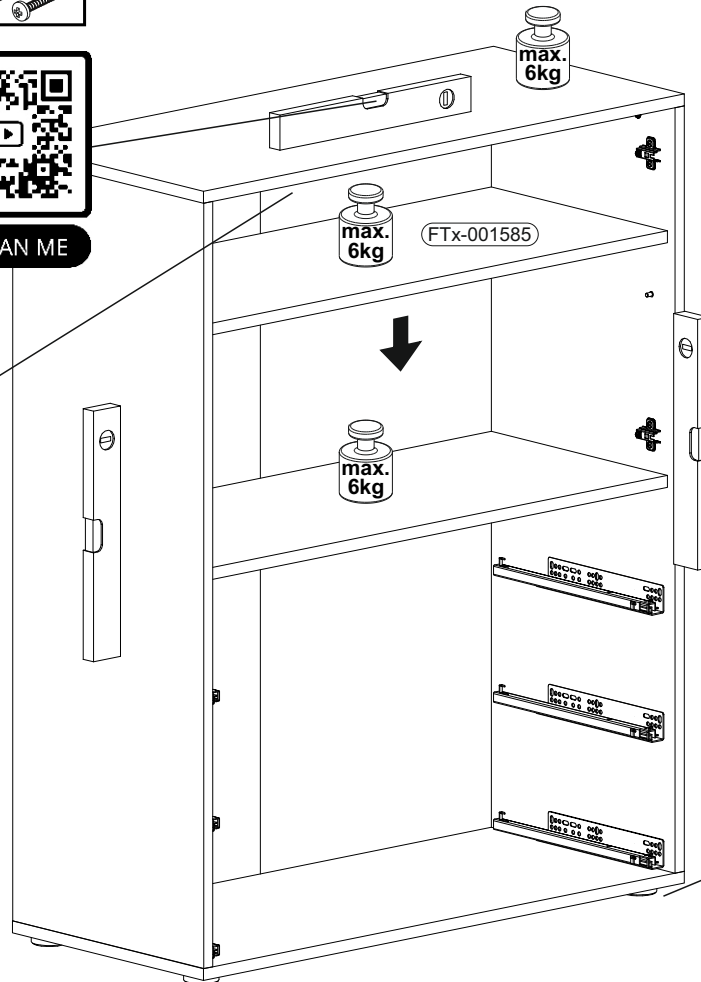
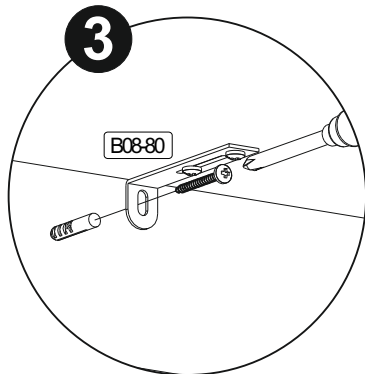

3



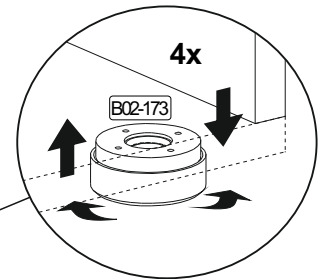

4x



 <b>Achtung • Attention • Attenzione • Opgelet • Uwaga • Pozor • Figyelem • Atenție • Dikkat • Внимание • Fara • Vaara • Fare • Peligro</b> 	
<b>(D)</b>	Wandbefestigung dient als Kippschutz - unbedingt anbringen! Bei einigen Wandtypen kann ein Spezialdübel erforderlich sein!
<b>(GB)</b>	The wall fastening serves to prevent tipping - be absolutely sure to mount it! For certain wall types, a special wall plug may be necessary!
<b>(FR)</b>	La fixation murale sert de protection contre le basculement – à installer impérativement ! Pour certains types de murs il faut des chevilles spéciales !
<b>(TR)</b>	Duvardaki sabitleme, devrilmeye karşı bir emniyet tedbiridir ve mutlaka monte edilmelidir! Bazı duvar tiplerinde bunun için özel bir dübel gerekli olabilir!
<b>(IT)</b>	Il fissaggio alla parete serve da protezione anti-ribaltamento – attaccarla assolutamente! Per alcune strutture di parete può essere necessario un tassello speciale!
<b>(NL)</b>	Bevestiging aan de muur dient als kantelbescherming – zeker en vast bevestigen! Bij enkele muurtypes is een speciale plug misschien vereist!
<b>(RU)</b>	Обязательно установите крепление на стене во избежание опрокидывания! Для некоторых типов стен может потребоваться специальный дюбель!
<b>(CZ)</b>	Montáž na stěnu slouží jako ochrana proti převrnutí – bezpodmínečně umístěte! U některých typů stěn může být zapotřebí speciální hmoždinka!
<b>(HU)</b>	A terméket a falhoz kel rögzíténi, különben az felborulhat! Egyes faltípusoknál speciális tiplit kell használni!
<b>(RO)</b>	Sistemul de fixare la perete servește ca protecție la răsturnare - de montat obligatoriu! Pentru unele tipuri de pereți este posibil să fie necesar un diblu special!
<b>(PL)</b>	Mocowanie do ściany jest jednocześnie zabezpieczeniem przed przewróceniem – koniecznie zamontować! Do niektórych rodzajów ścian koniecznie zastosować specjalne kołki mocujące.
<b>(SWE)</b>	Väggmontering fungerar som anti-lutningskydd - det är viktigt att fästa det! En speciell plugg kan behövas för vissa väggtyper!
<b>(FIN)</b>	Seinäkiinnitys toimii kaatumista estävänä suojana - se on ehdottomasti kiinnitettävä! Joihinkin seinätyypeihin voidaan tarvita erityistappi!
<b>(NOR)</b>	Veggmontering fungerer som anti-vippebeskyttelse - det er viktig å feste det! En spesiell dyvel kan være nødvendig for noen veggtyper!
<b>(DAN)</b>	Vægmontering fungerer som anti-vip beskyttelse - det er vigtigt at fastgøre det! En speciel dyvel kan være påkrævet til nogle vægtyper!
<b>(SK)</b>	Upevnenie na stenu slúži ako ochrana proti prevráteniu – bezpodmienečne použite! Pre niektoré druhy stien môže byť potrebná špeciálna hmoždinka!
<b>(ES)</b>	El montaje en la pared sirve como protección antivuelco: ¡es imprescindible fijarlo! ¡Es posible que se requiera una espiga especial para algunos tipos de paredes!

15

	B05-20	
	12x	ø20mm

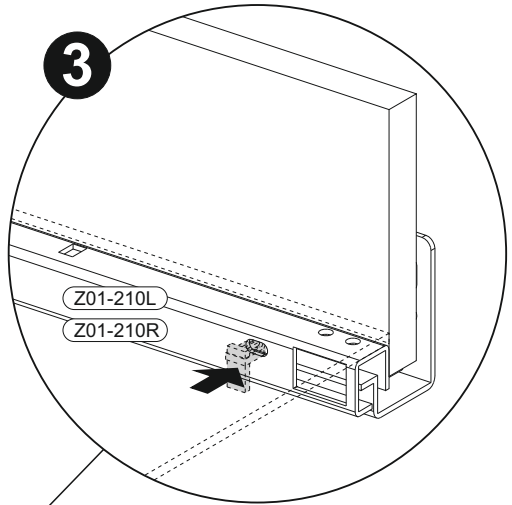
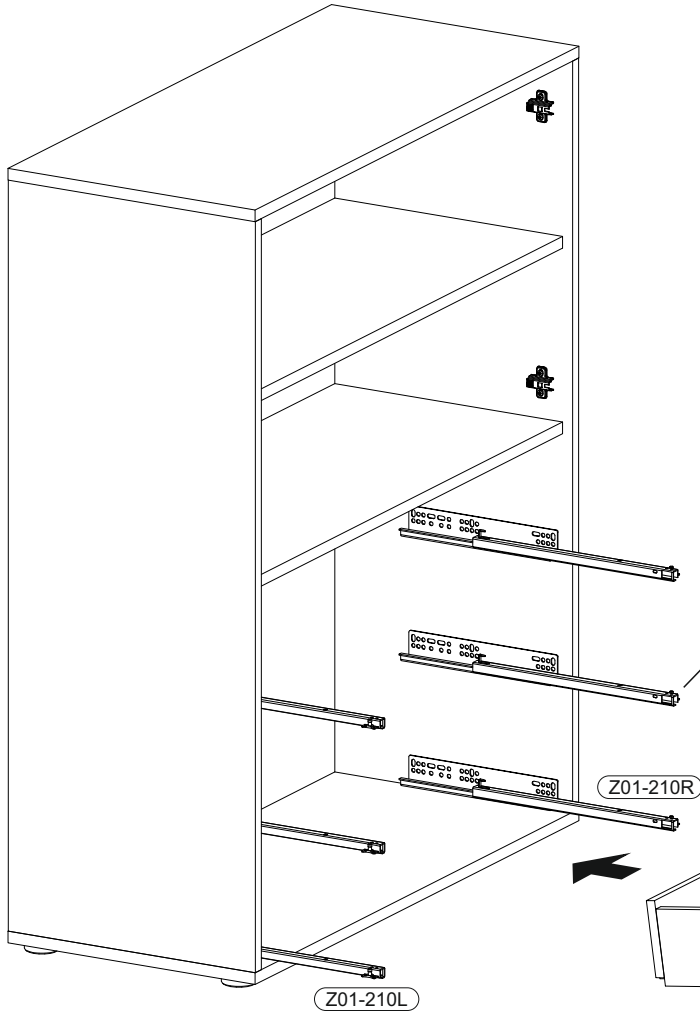
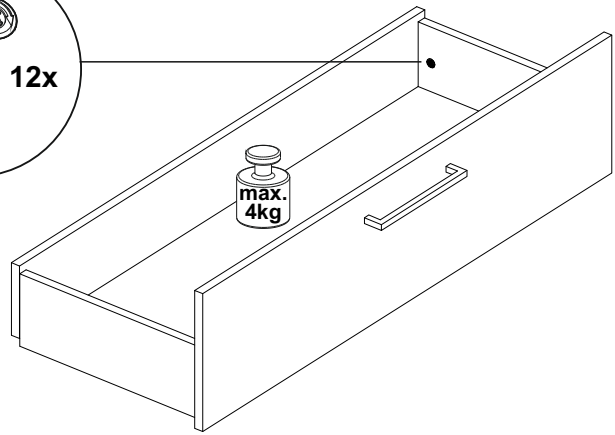
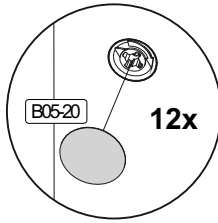

1

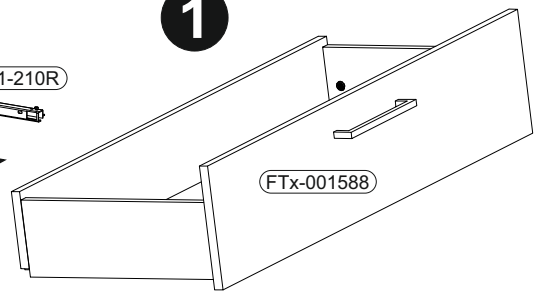

2

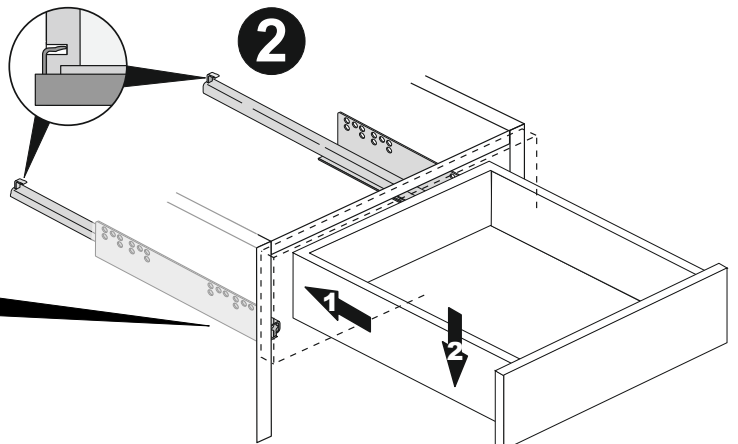

SCAN ME

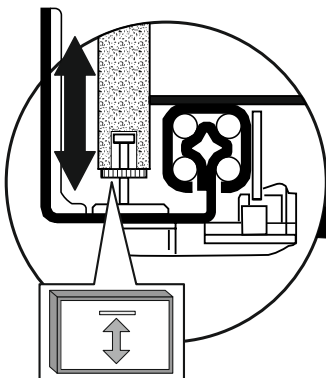

16

	B05-20		B03-07	
	16x	ø20mm	2x	

3

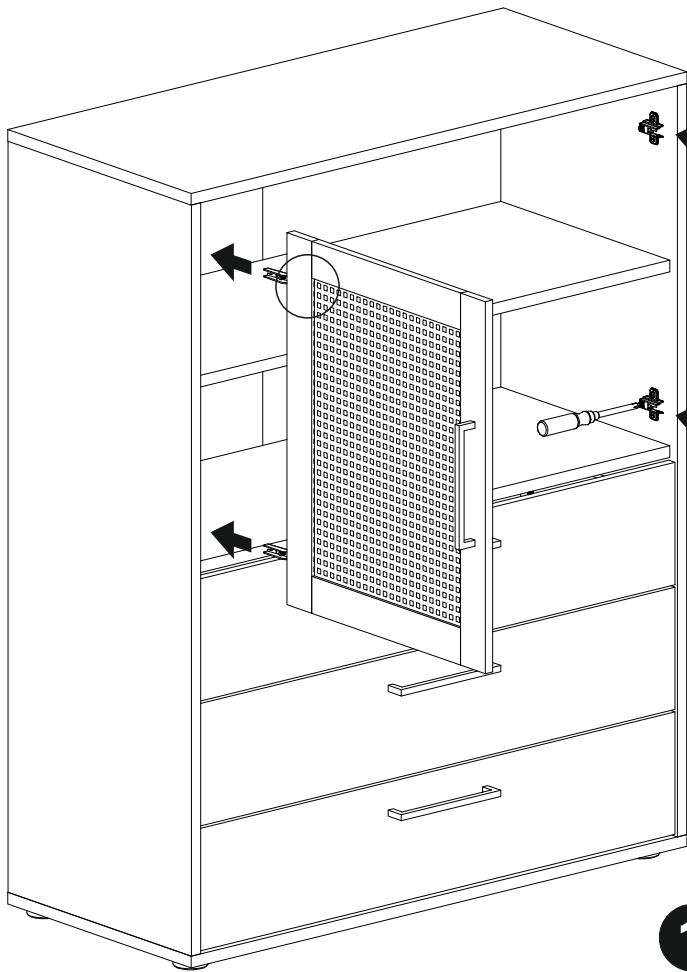
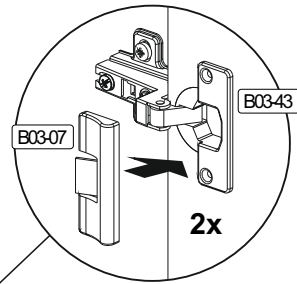
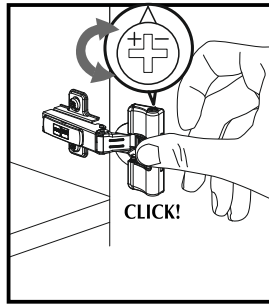
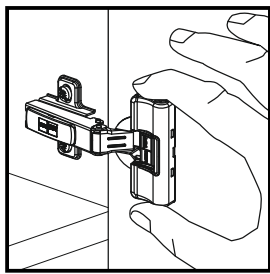
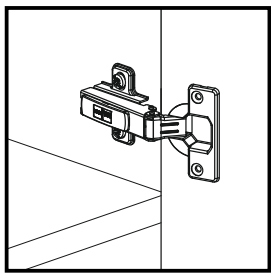

1

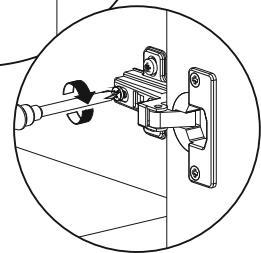
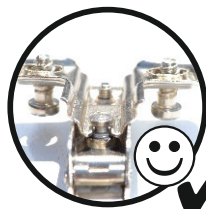
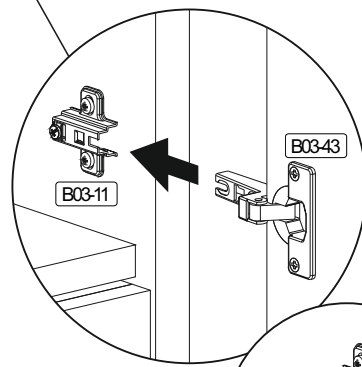
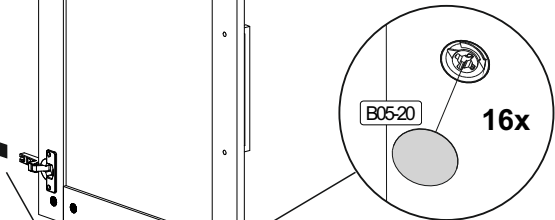

2



SCAN ME

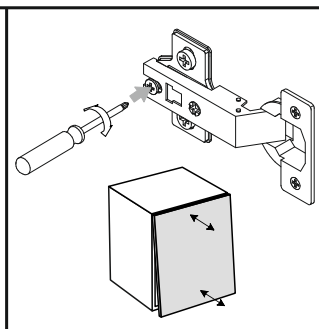
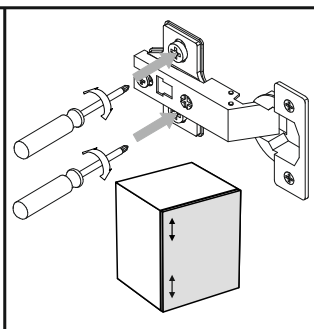
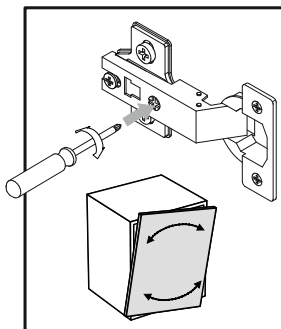

REPC-Nr.:

Service • Assistenza • Dienstverlening • Serwis  
Servis • Szerviz • Сервисная служба

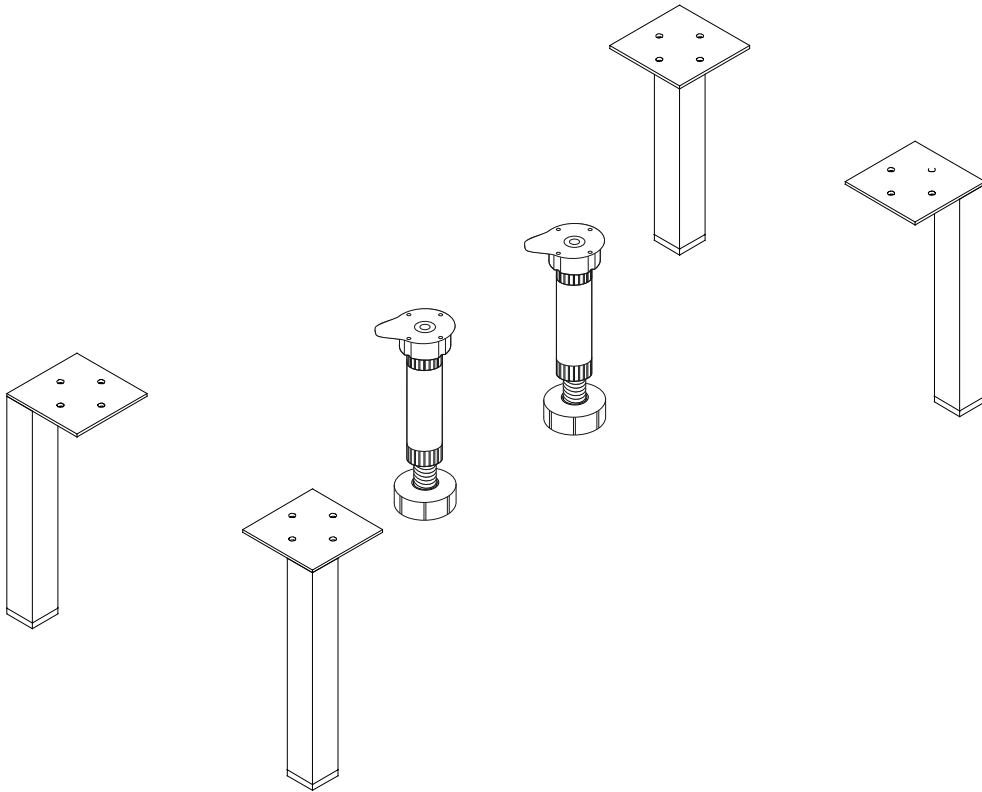

Artikel.-Nr.:

**0800-4er Füße Quadrat**

Montageanleitung.-Nr.:

**MA1-00207**

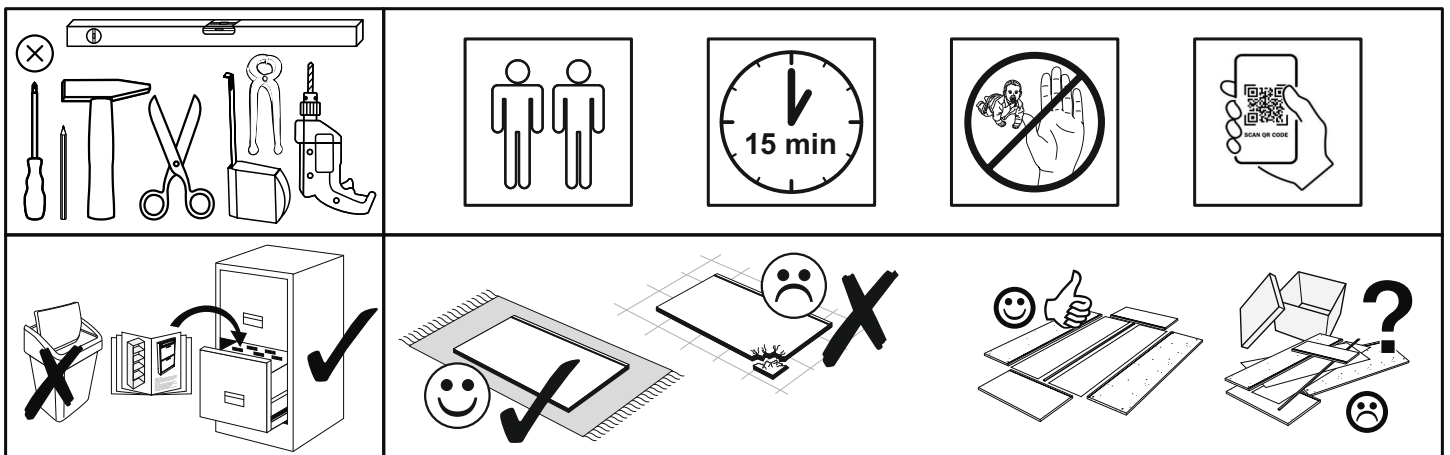

SCAN ME

Das Ersatzteil-Anforderungsformular finden Sie auf  
The replacement parts requisition form you find on  
<https://www.maeusbacher.de/ersatzteile/>

B01-90	
24x	3,5x20

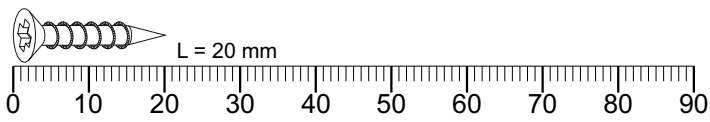

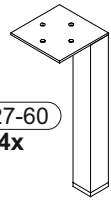
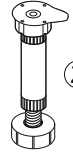
	
Z27-60 4x	Z03-100 2x
150x20x20mm	136-170mm

**1**

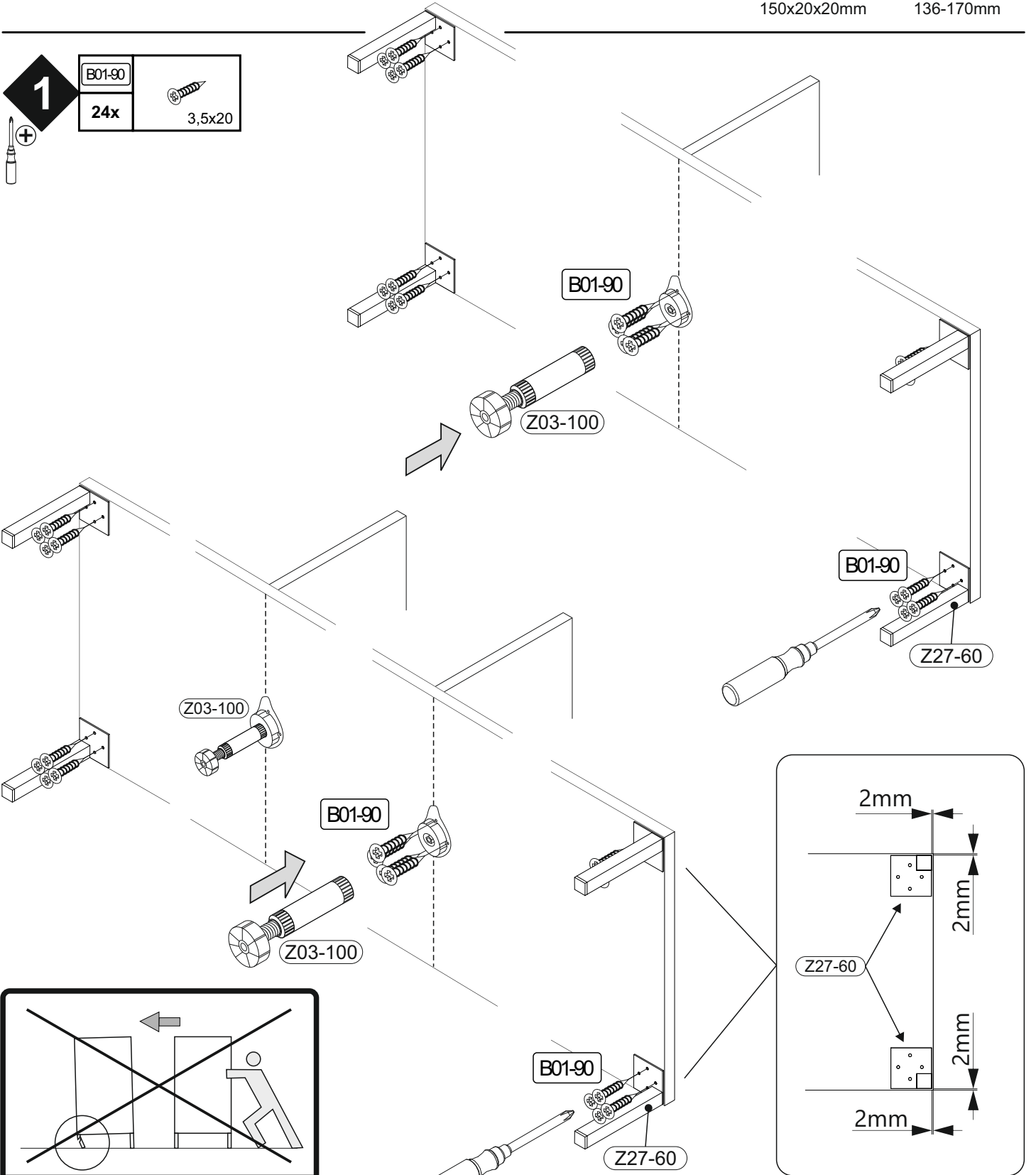
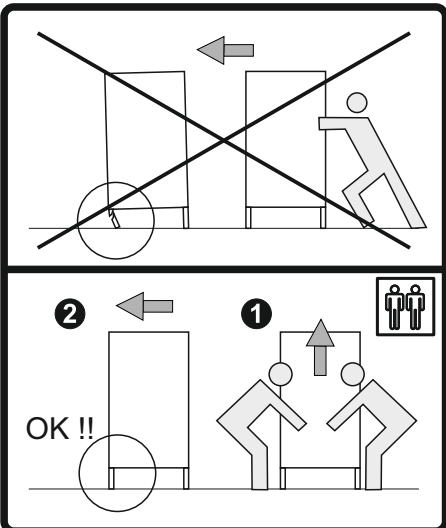

B01-90	
24x	3,5x20

The safety diagram shows two scenarios. The top scenario, marked with a large 'X', shows a person leaning against a rail that is not properly secured, which is unsafe. The bottom scenario, marked 'OK !!', shows a person leaning against a rail that is properly secured, which is safe. The diagram also includes a warning icon of two people.