

**clickat**  
by feandrea

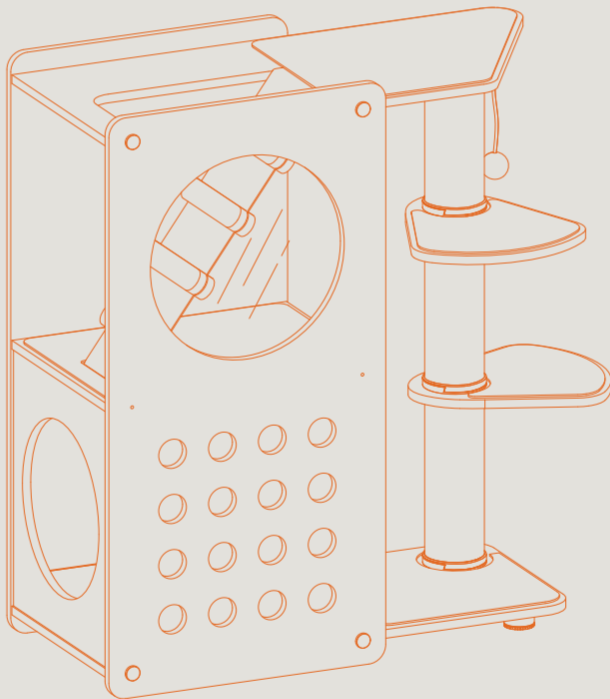

**Cat Tree**



---

EN

## General Guidelines

Read the following instructions carefully and use the product accordingly.

Keep this manual and hand it over when you transfer the product.

This summary may not include every detail of all variations and considered steps. Contact us if further information and help are needed.

---

DE

## Einleitung

Bitte lesen Sie die folgende Anleitung aufmerksam durch und verwenden Sie das Produkt sachgemäß.

Bewahren Sie diese Anleitung gut auf und händigen Sie sie bei Weitergabe des Produkts an Dritte ebenfalls mit aus.

Aus Gründen der Übersicht können nicht alle Details zu allen Varianten und denkbaren Montagen beschrieben werden. Wenn Sie weitere Informationen und Hilfe benötigen, kontaktieren Sie uns bitte.

---

FR

## Introduction

Lisez attentivement ces instructions et utilisez votre produit d'après ce mode d'emploi.

Conservez ces instructions. Si vous souhaitez offrir ce produit à un tiers, joignez obligatoirement ce mode d'emploi.

Pour des raisons de clarté, les détails concernant chaque variante ou montage envisageable ne peuvent être tous décrits. Si vous souhaitez obtenir plus d'informations ou si vous rencontrez certains problèmes non traités de manière détaillée dans ces instructions, veuillez nous contacter.

---

IT

## Linee Guida Generali

Si prega di leggere attentamente le seguenti istruzioni e usare il prodotto in modo opportuno.

Si prega di conservare questo manuale e consegnarlo quando il prodotto cambia proprietario.

Questo riassunto potrebbe non includere ogni dettaglio di tutte le variazioni e le fasi considerate. Contattaci se hai bisogno di ulteriori informazioni e assistenza.

---

ES

## Acerca del manual

Por favor, lea detenidamente las instrucciones y respete los debidos usos del producto.

Por favor, conserve bien este manual y en caso de cesión, no omita entregarlo junto al producto.

Este manual podría no incluir todos los detalles de cada paso del montaje. Si necesita ayuda o información adicional, póngase en contacto con nosotros.

---

**NL**

## Algemene Richtlijnen

Gelieve de handleiding na te lezen en het product volgens de beschrijving te gebruiken.

Gelieve de handleiding bij te houden en bij verkoop mee te geven aan de nieuwe gebruiker.

Deze samenvatting bevat mogelijk niet alle variaties en stappen. Gelieve contact met ons op te nemen indien u meer informatie of hulp nodig hebt.

---

**SE**

## Allmänna riktlinjer

Var god läs följande instruktioner noggrant och använd produkten därefter.

Var god behåll den här manualen och överlämna den när du överför produkten.

Denna sammanfattning kanske inte innehåller alla detaljer i alla variationer och övervägda steg. Kontakta oss om ytterligare information och hjälp behövs.

---

**PL**

## Ogólne Porady

Proszę uważnie przeczytać niniejsze instrukcje oraz odpowiednio używać produkt.

Proszę zachować instrukcję oraz przekazać razem z produktem podczas transferu zmiany własności.

Podsumowanie to może nie zawierać wszystkich detali każdej z wersji oraz uwzględnionych kroków. Skontaktuj się z nami jeśli potrzebujesz więcej informacji albo pomocy.

---

**TR**

## Genel kurallar

Lütfen aşağıdaki talimatları dikkatlice okuyun ve ürünü belirttiği şekilde kullanın.

Lütfen bu kılavuza saklayın ve ürünü teslim ederken karşı tarafa verin.

Bu özet, tüm varyasyonları ve dikkate alınan adımları bütünüyle içermeyebilir. Ek bilgi veya yardım gerekirse lütfen bizimle iletişime geçin.

---

**JP**

## 序言

ご使用前に取扱説明書をよくお読みになり、内容を理解された上で、ご使用くださいますようお願い致します。

この商品を第三者に貸し出す際に、本取扱説明書を共に貸し出し、よく読んでから使用するようご指導ください。

さらに詳しい情報やサポートが必要な場合は、弊社までお気軽にお問い合わせください。

**A5** x1

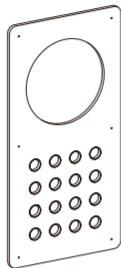

**B5** x1

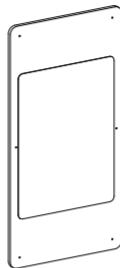

**C5** x1

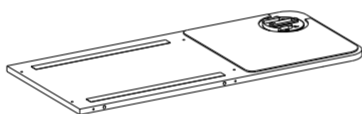

**D5** x1

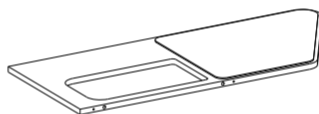

**E5** x1



**F5** x1

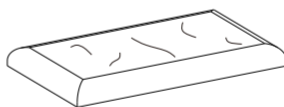

**G5** x2



**H5** x1



**J5** x3



**K5** x1

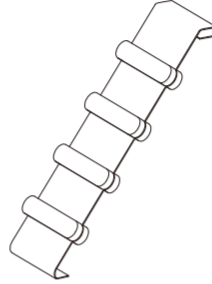

**L5** x1

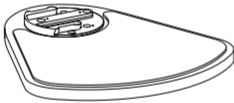

**M5** x1

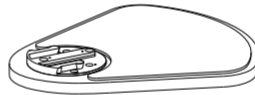

**N5** x1





Hardware (Included)

Zubehörteile (im Lieferumfang enthalten)

Quincaillerie (incluse)

1 x 20

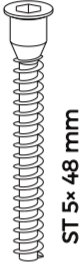

2 x 12



3 x 4

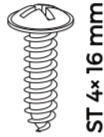

4 x 2



5 x 2



6 x 8



7 x 1



Note: During assembly, please ensure you use the hardware we have provided.

Hinweis: Bitte stellen Sie sicher, dass Sie bei der Montage die von uns bereitgestellten Zubehörteile verwenden.

Remarque: Pour le montage, veuillez utiliser la quincaillerie fournie.

### Tools Required (Not Included)

Erforderliche Werkzeuge (nicht im Lieferumfang enthalten)

Outils nécessaires (non inclus)

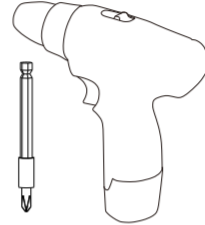
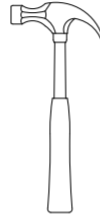
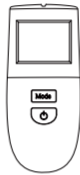

**Note:** During assembly, please ensure you use an electric screwdriver and an extended driver bit to make the installation easy.

**Hinweise:** Bitte verwenden Sie während der Montage einen Akkuschauber und ein verlängertes Schrauber-Bit, um die Montage zu erleichtern.

**Remarque:** Pour le montage, utilisez un tournevis électrique et un embout de vissage long pour plus de facilité.

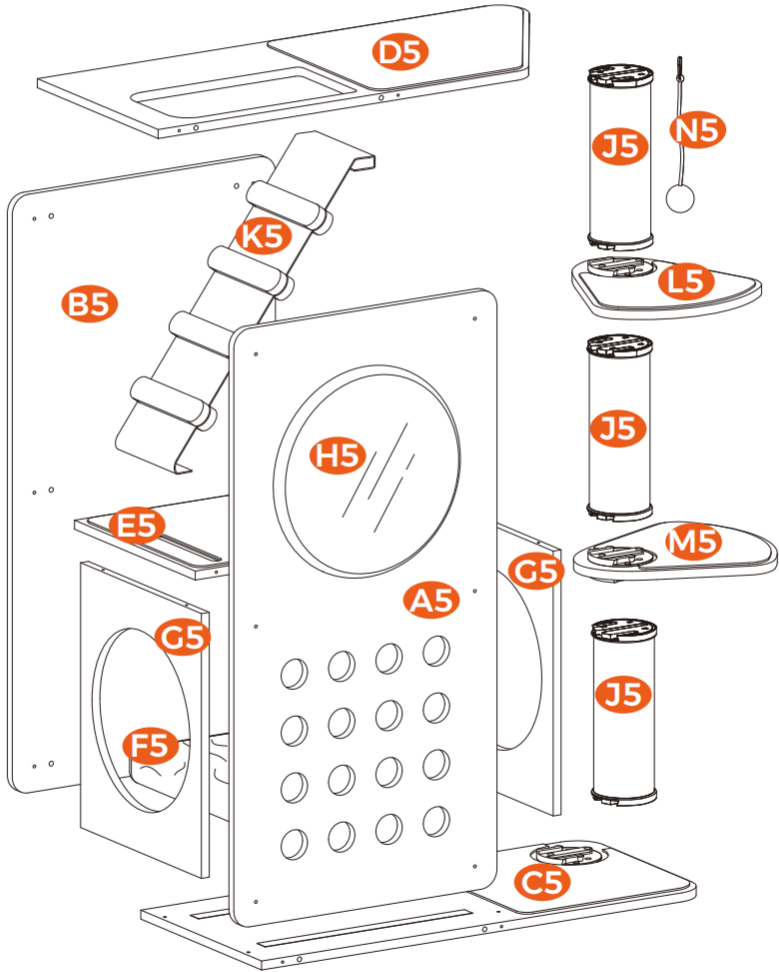



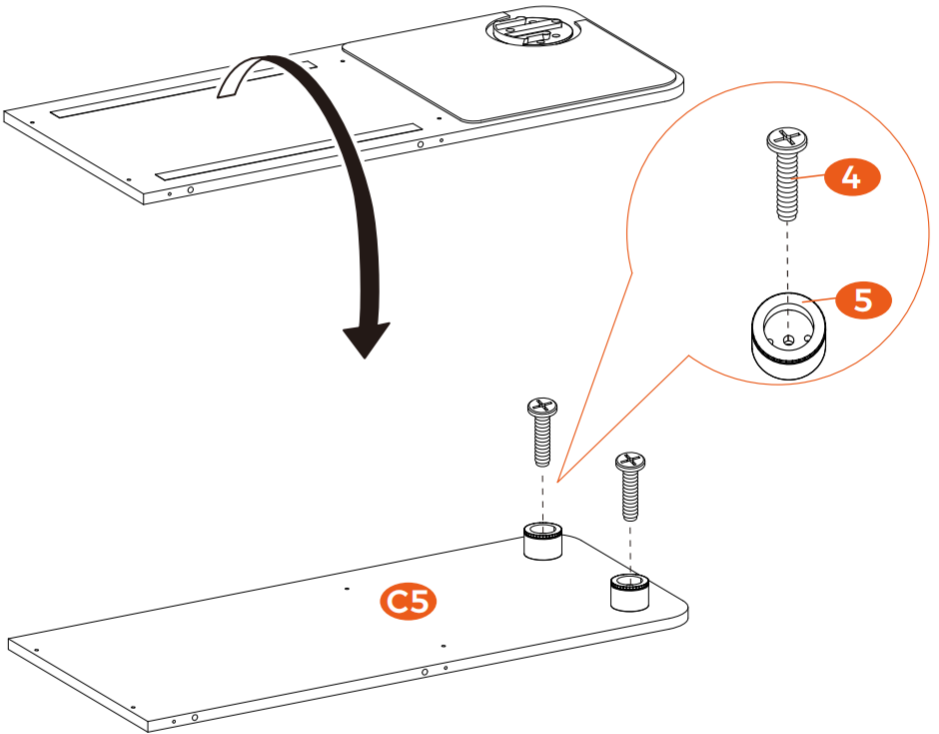

1

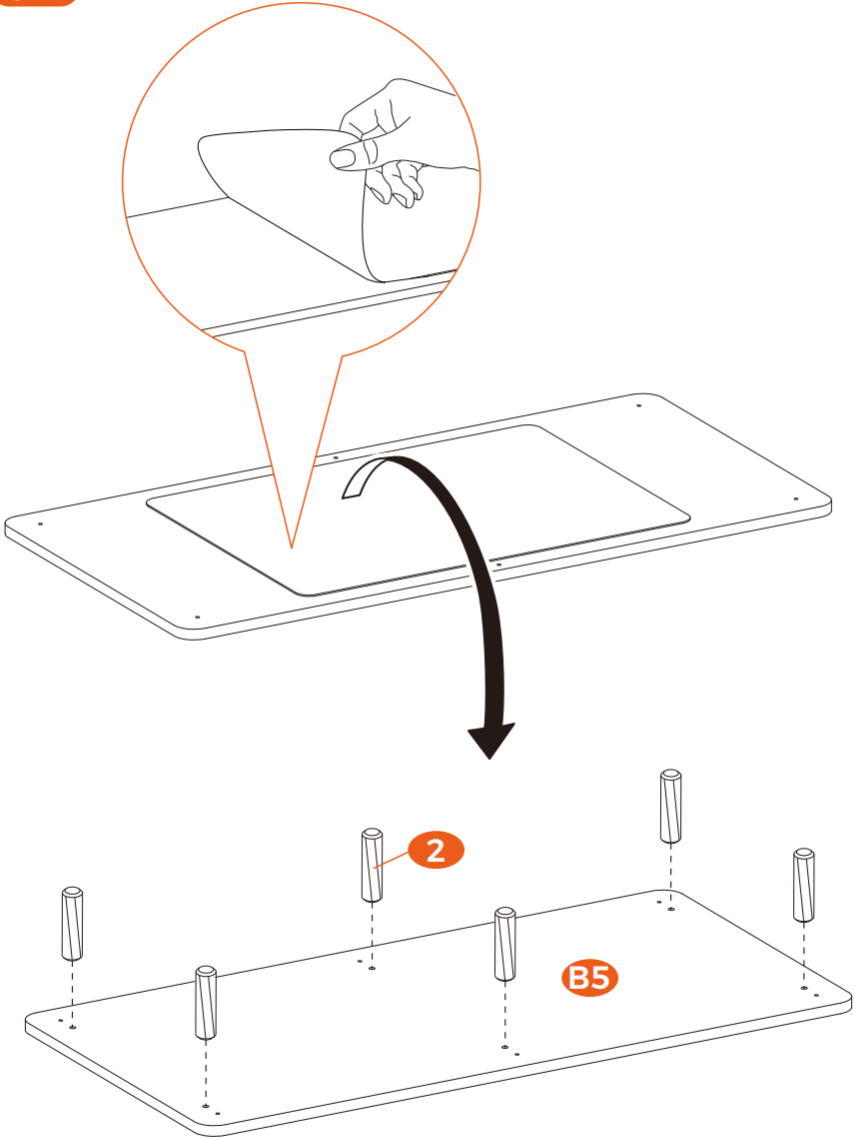

2



2 |  | x 6

3

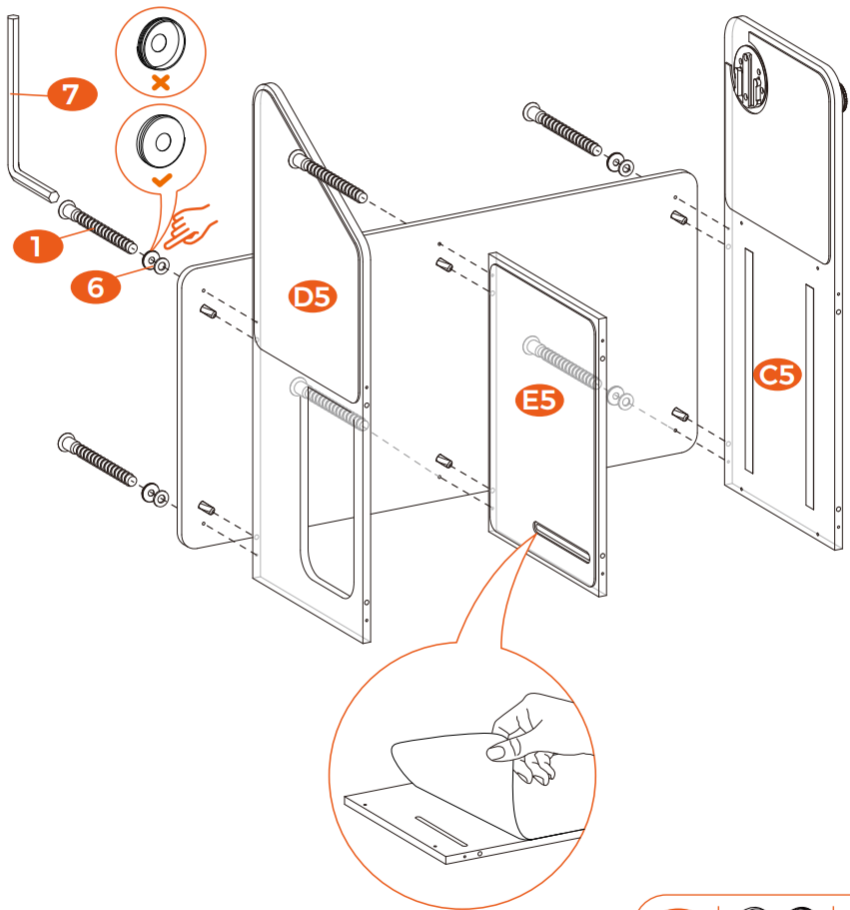

6		× 4
---	--	-----

1		× 6
---	--	-----

4

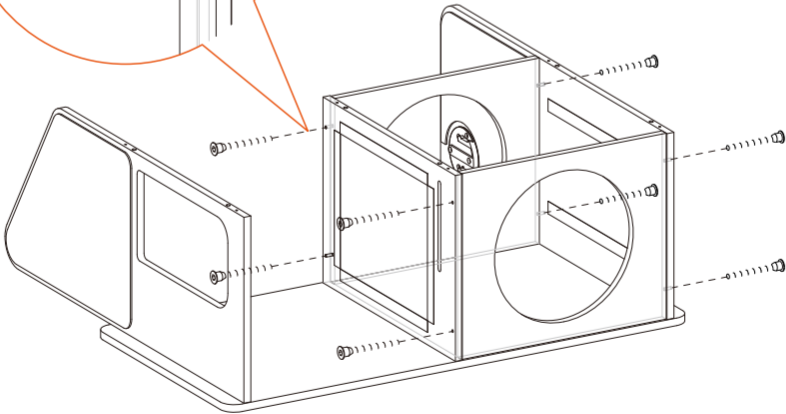
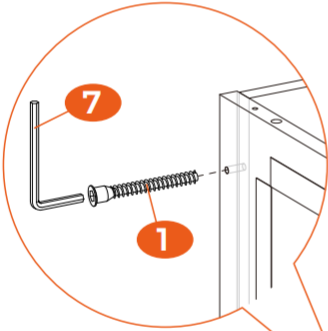
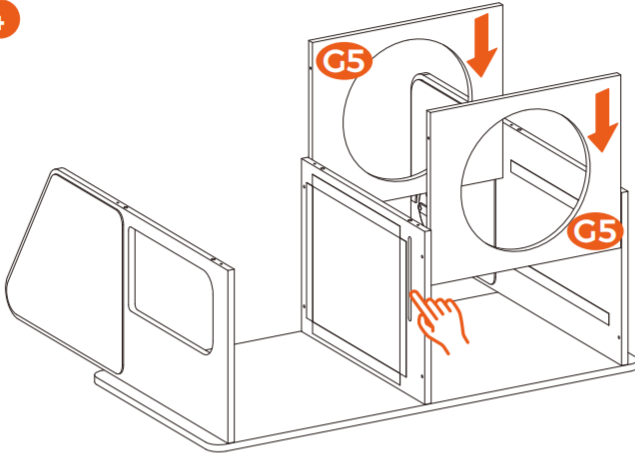

1  × 8

5

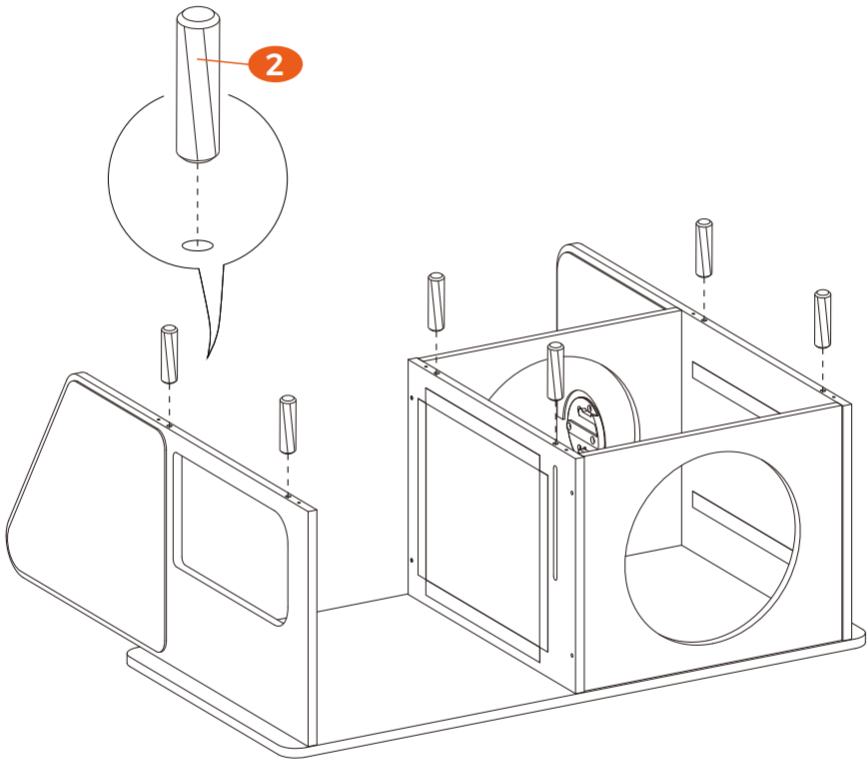

2  x 6

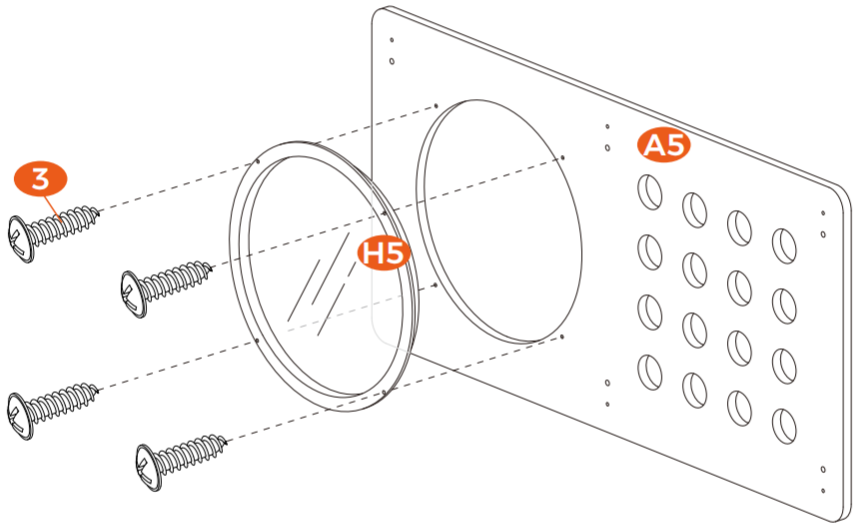

7

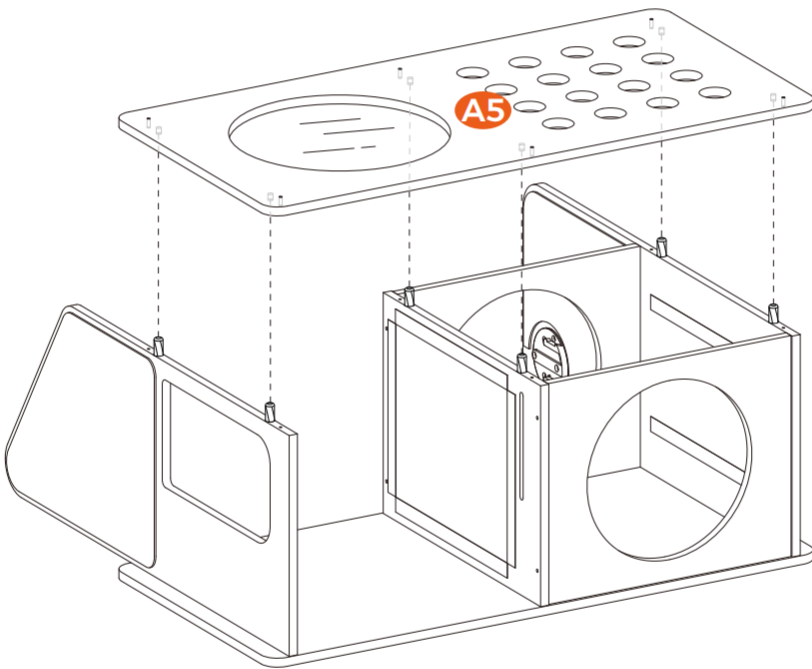

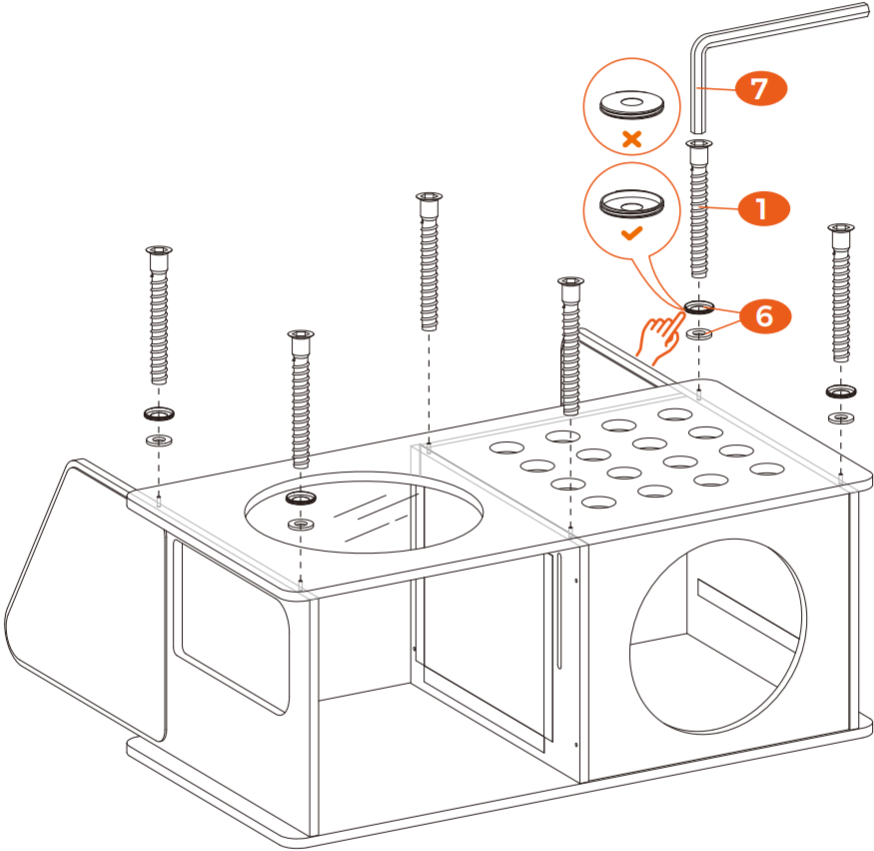

6 |  × 4

1 |  × 6



9

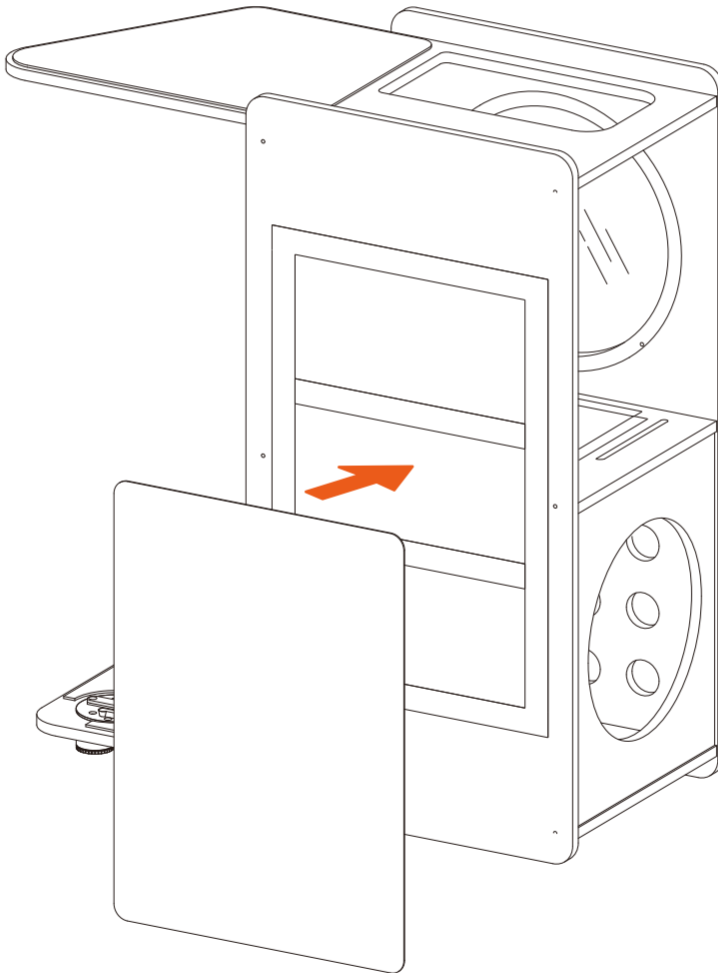

10

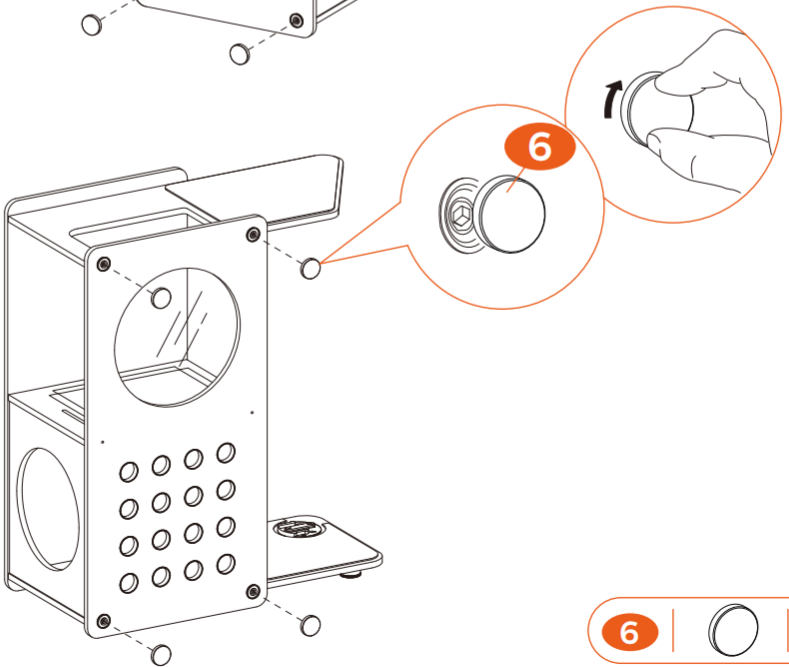
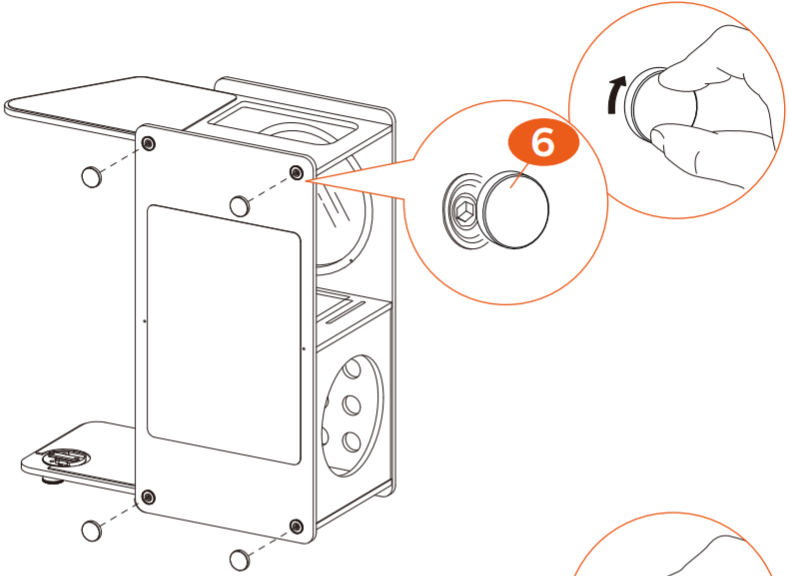

6 |  | x 8

11

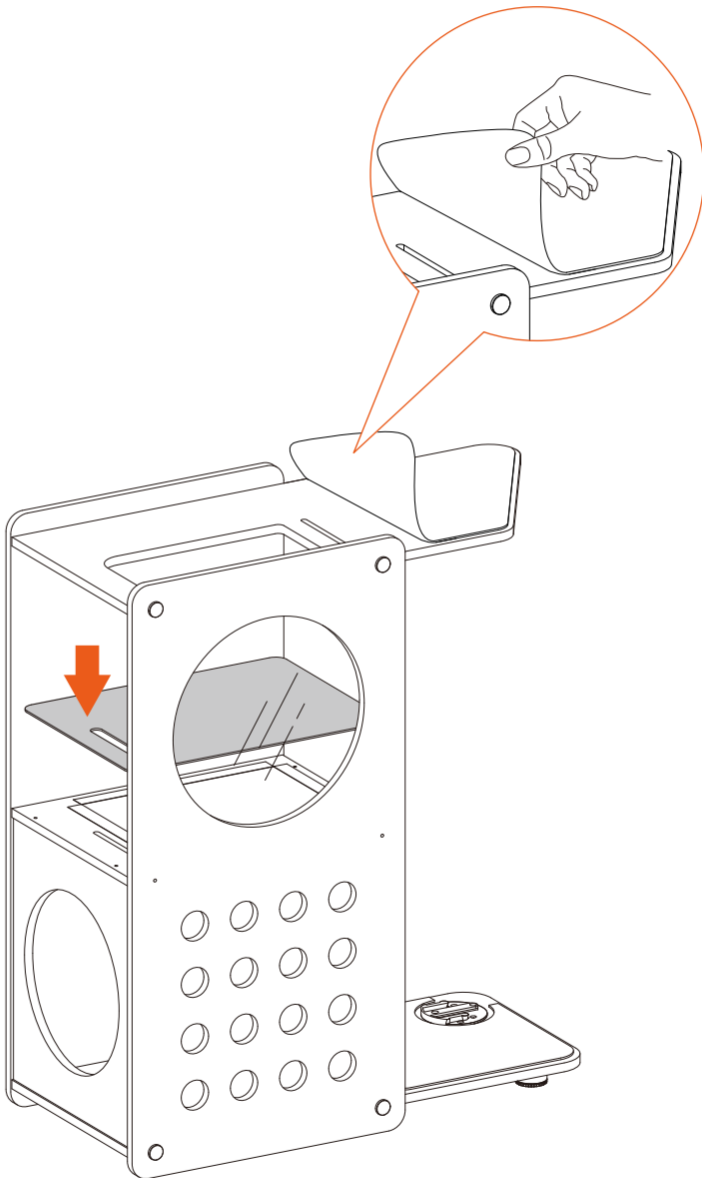

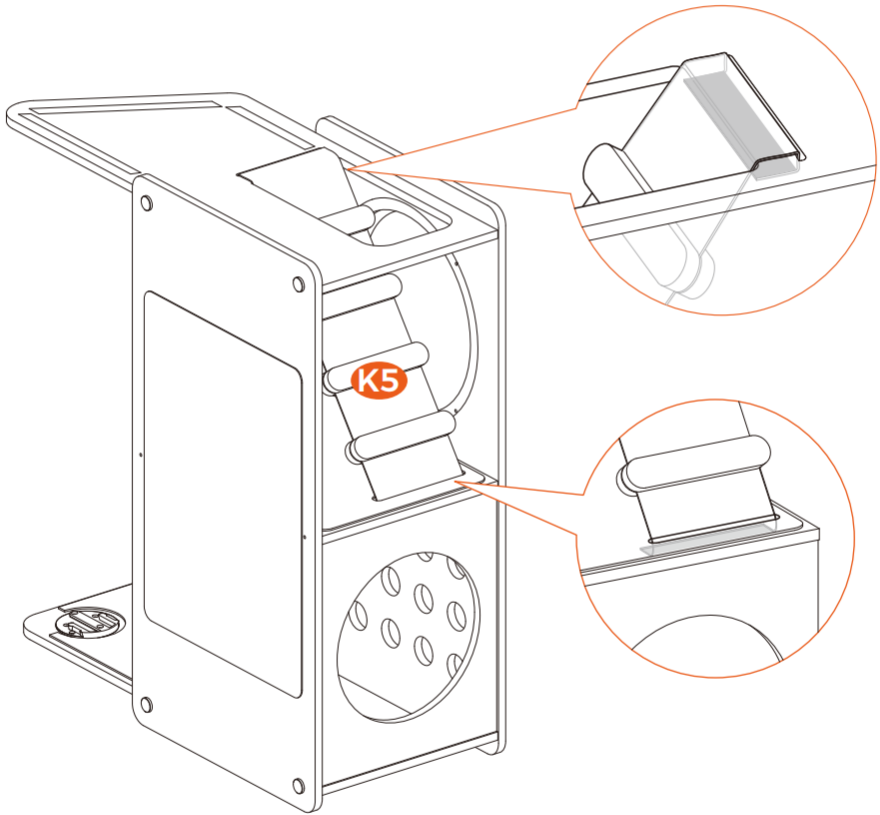

13

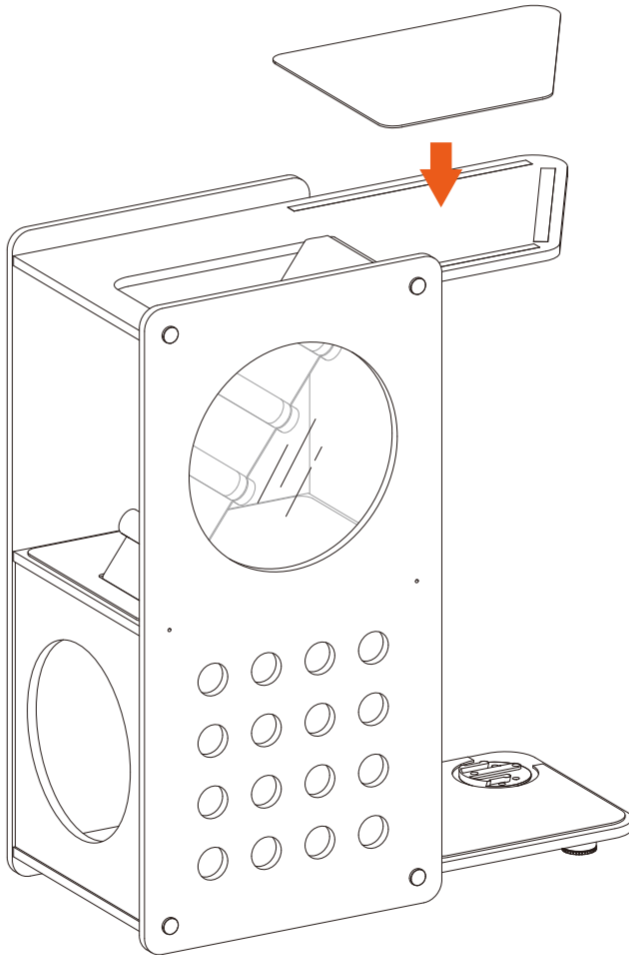

14

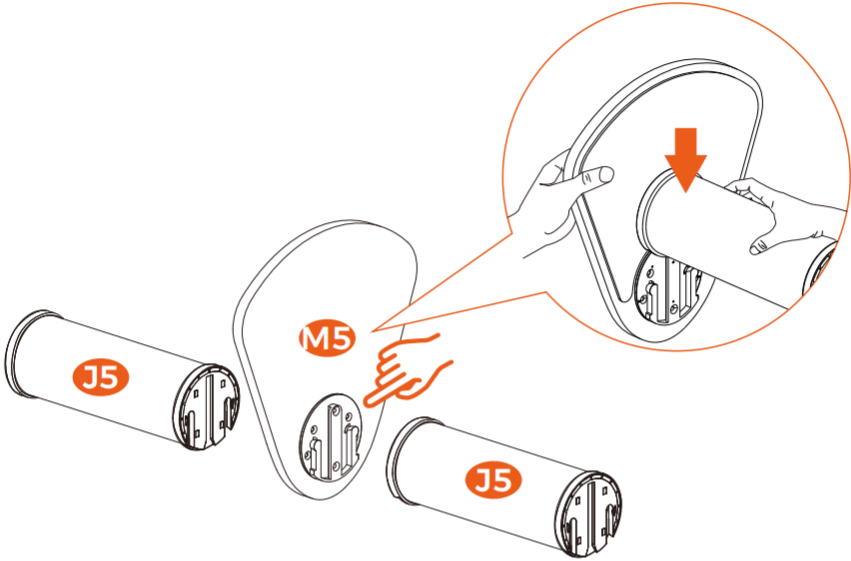

15

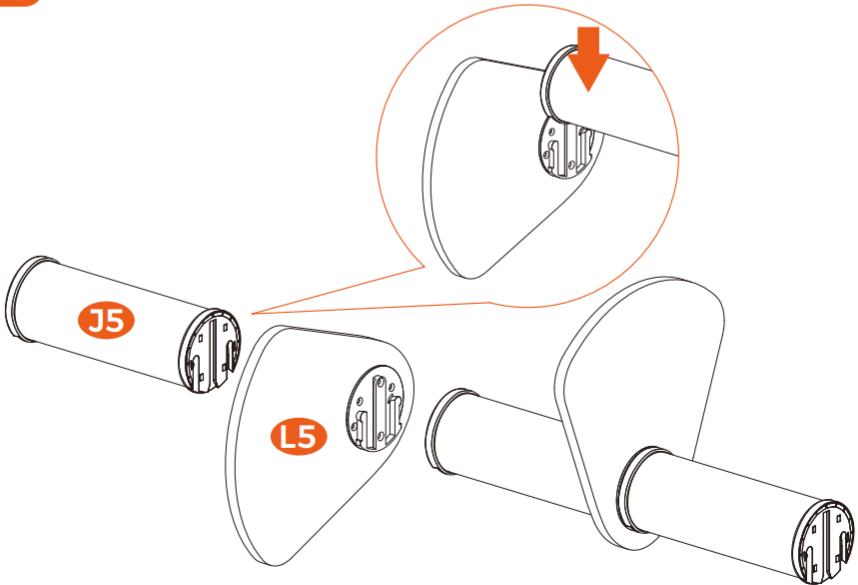

16

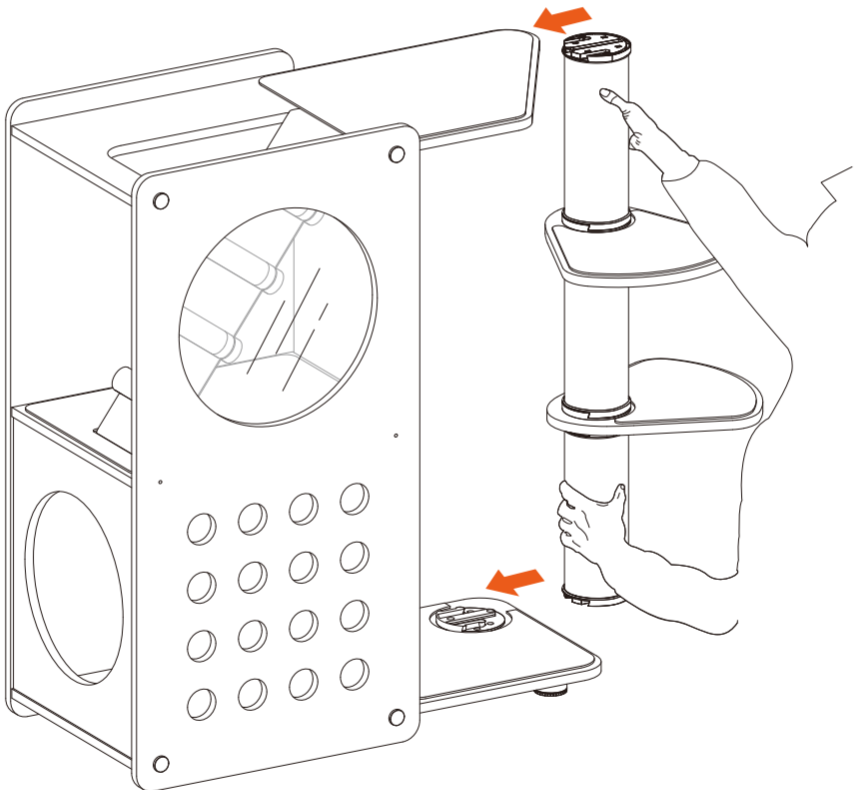

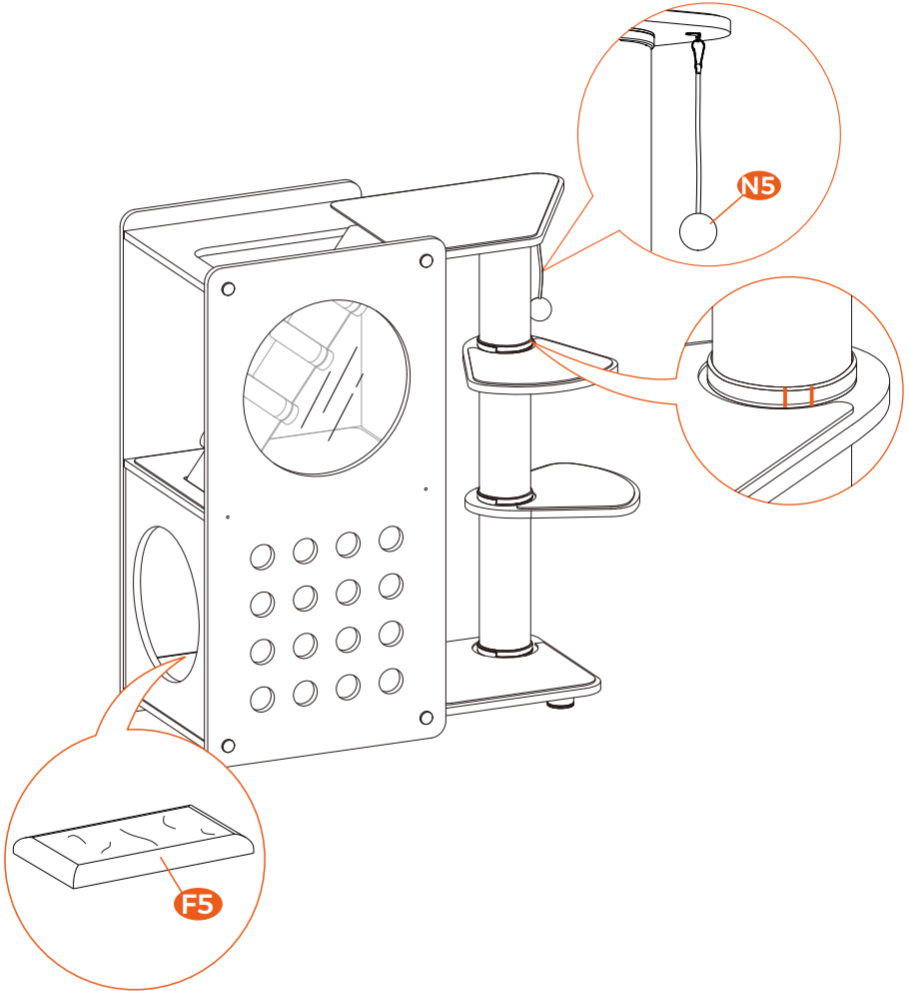



- Combination
- Kombination
- Combinaison

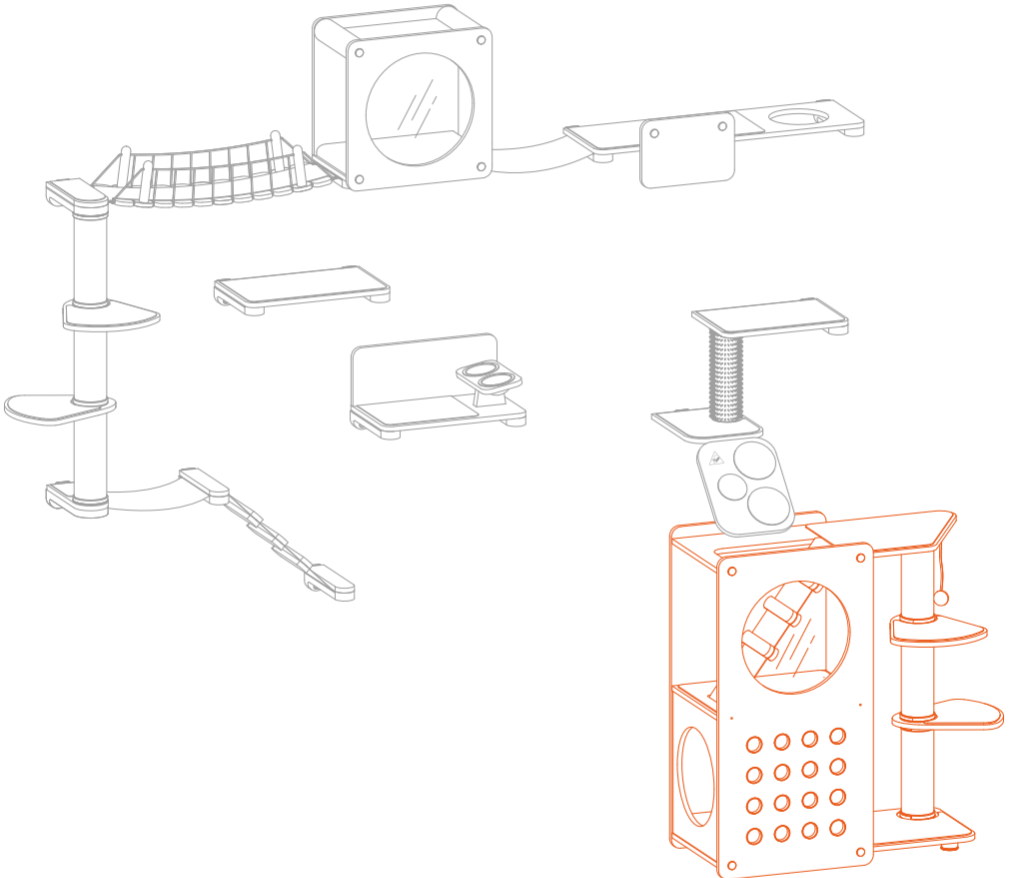

## Disassembly Tips:

- Follow the directions indicated in the diagram, and gently tap the top and bottom ends of the scratching post with moderate force.
- Continue to tap evenly until the scratching post loosens from the bases, and then slide it out.

## Tipps zum Abbau:

- Befolgen Sie die Anweisungen in der Abbildung und klopfen Sie vorsichtig mit mäßigem Kraftaufwand auf das obere und untere Ende der Kratzsäule.
- Klopfen Sie gleichmäßig weiter, bis sich die Kratzsäule von den Basen des Produktes löst, und ziehen Sie sie anschließend heraus.

## Conseils pour le démontage :

- Suivez les instructions indiquées dans le diagramme et tapez doucement sur les extrémités supérieure et inférieure du griffoir avec une force modérée.
- Continuez à taper uniformément jusqu'à ce que le poteau se détache des bases, puis faites-le glisser pour le retirer.

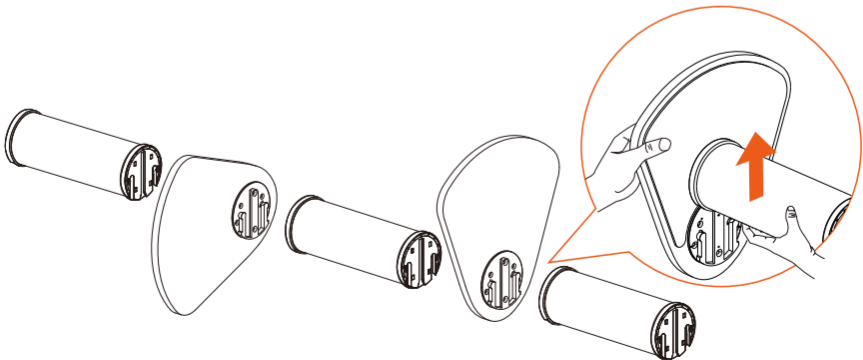
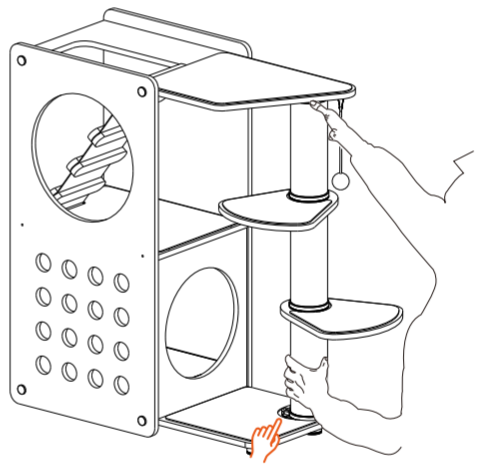
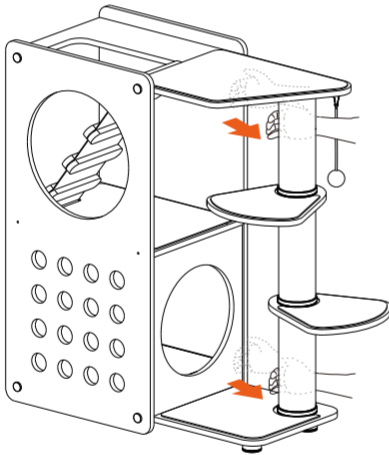

- Cleaning
- Reinigung
- Nettoyage

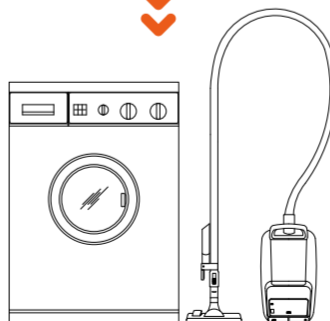
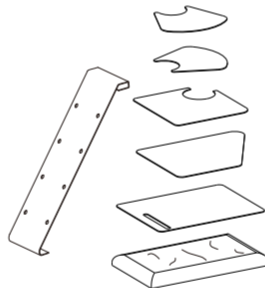
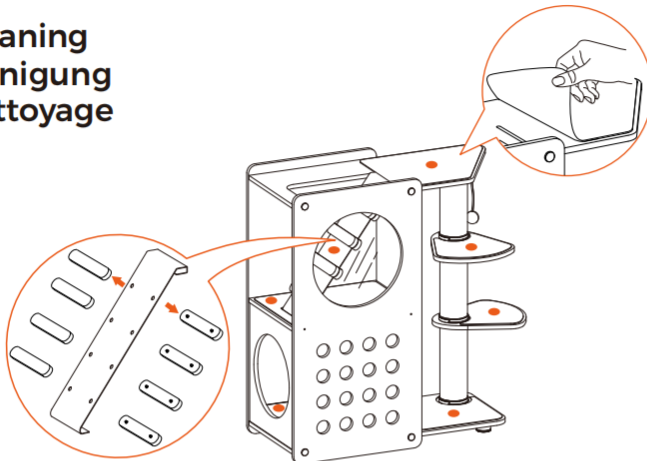



- Replacement
- Ersatzteile
- Remplacement

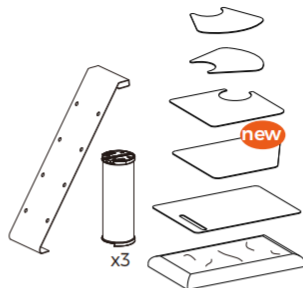
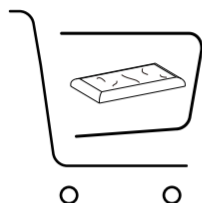

Note: These parts are consumable. It is recommended to replace them every 3 to 6 months. If damaged, you can purchase spare parts separately.

Hinweis: Diese Teile sind Verschleißteile. Es wird empfohlen, sie alle 3 bis 6 Monate auszutauschen. Bei Beschädigungen können Sie Ersatzteile separat bestellen.

Remarque: Ces pièces sont des consommables. Il est recommandé de les remplacer tous les 3 à 6 mois. Si elles sont abîmées, vous pouvez acheter des pièces de rechange séparément.

## Care & Maintenance

### Cotton-Linen Fabrics & Felt Pads:

- Use a lint roller weekly to remove fur, dirt, and fluff.
- Machine wash on a gentle cycle in water below 40°C; hang to dry.

### Panel Surfaces:

- Wipe down with a cloth dampened in a diluted soap/water mixture.

### Scratching Post Segments:

- Not washable. Remove and replace them when they become worn out.

## Pflege und Wartung

### Baumwoll-Leinen-Gewebe & Filz pads:

- Verwenden Sie wöchentlich eine Fusselrolle, um Haare, Schmutz und Fusseln zu entfernen.
- Maschinenwäsche im Schonwaschgang bei einer Temperatur unter 40°C; zum Trocknen aufhängen.

### Oberfläche der Platten:

- Mit einem Tuch, das mit einer verdünnten Mischung aus Wasser mit Seife angefeuchtet wird, abwischen.

### Abschnitte der Kratzsäule:

- Nicht waschbar. Entfernen und ersetzen Sie diese, wenn sie abgenutzt sind.

## Entretien et maintenance

### Tissus coton-lin et tampons en feutre :

- Passez dessus un rouleau à peluches chaque semaine pour enlever les poils, la saleté et les peluches.
- Lavez-les en machine sur cycle délicat à une température inférieure à 40 °C ; suspendez-les pour sécher.

### Surfaces des panneaux :

- Essuyez-les avec un chiffon imbibé d'un mélange d'eau et de savon dilué.

### Segments du griffon :

- Ne sont pas lavables. Les retirer et les remplacer lorsqu'ils sont usés.

# Take It Easy, Make It Fancy

