

Installationsanleitung/Installation Instruction/Instruction d'installation  
Istruzioni di installazione/Instrucciones de instalación  
**BARCOUNTER- N620P206331/N620P206332**

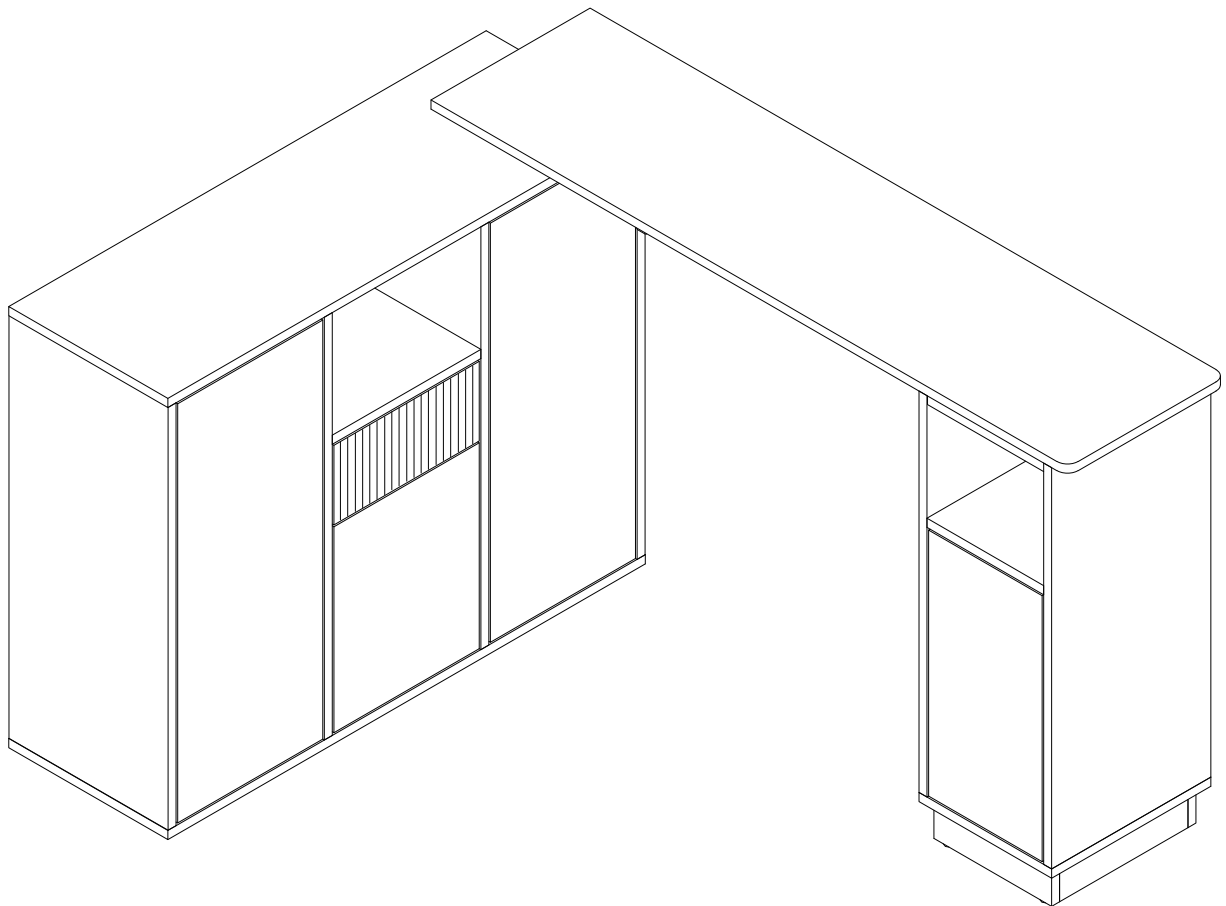

DE: Unser Produkt wird Ihnen in 2 Paketen geliefert. Die Lieferzeiten dieser 2 Pakete können abweichen, bitte haben Sie etwas Geduld und vielen Dank für Ihr Verständnis.

UK: Our product will be delivered to you in 2 packages. The delivery times of these 2 packages may differ, please be patient and thank you for your understanding.

FR: Notre produit vous sera livré en 2 colis. Les délais de livraison de ces 2 colis peuvent différer, soyez patient et merci pour votre compréhension.

IT: Il nostro prodotto verrà consegnato in 2 pacchi. I tempi di consegna di questi 2 pacchi possono variare; vi preghiamo di avere un po' di pazienza e vi ringraziamo per la vostra comprensione.

ES: Nuestro producto se entregará en 2 paquetes. Los tiempos de entrega de estos 2 paquetes pueden variar; por favor, tenga un poco de paciencia y gracias por su comprensión.

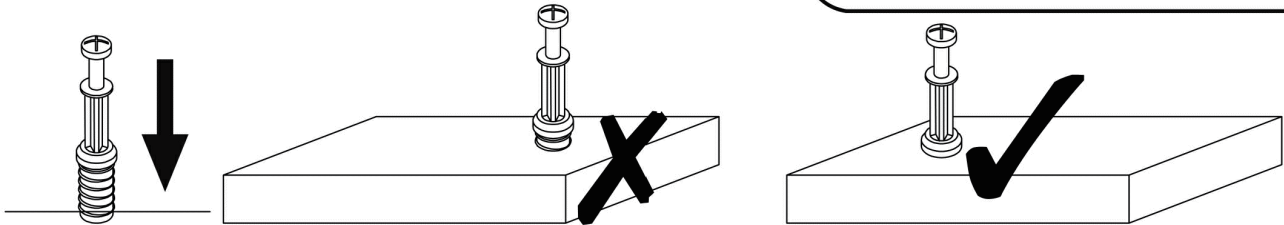

**EN\_QUICKFIT:** Tighten quickfit until shoulder is flush with panel. Do not overtighten or undertighten.

**FR\_RACCORD RAPIDE:** Faites serrer le raccord rapide jusqu'à ce que l'épaulement soit parfaitement encastré dans le panneau. Il ne faut ni trop serrer ni insuffisamment serrer.

**ES\_QUICKFIT:** Apriete quickfit hasta que el hombro se descargue con el panel. NO lo sobreapriete ni lo apriete poco.

**DE\_QUICKFIT:** Ziehen Sie den Quickfit fest, bis die Schulter mit der Platte bündig ist. Bitte nicht zu fest oder zu schwach anziehen.

**IT\_MONTAGGIO RAPIDO:** Stringere il montaggio rapido fino a quando la spalla è a filo con il pannello, non stringere troppo o troppo poco.

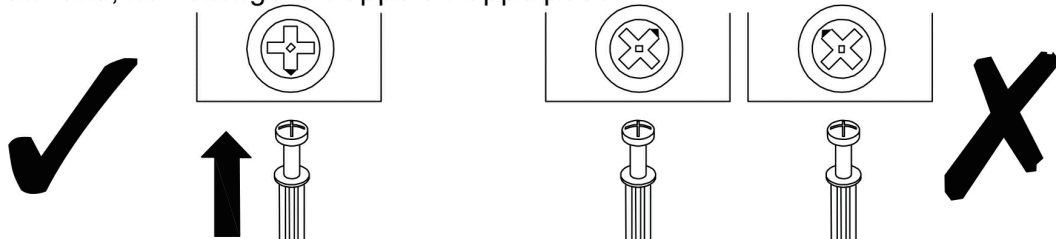

**EN\_CAM LOCK:** When fitting cam lock, ensure starting position is correct before you insert connecting quickfit.

**FR\_SERRURE BATTEUSE:** Avant d'insérer la serrure batteuse, veillez à la bonne orientation avant d'insérer le raccord rapide.

**ES\_CIERRE DE LA CÁMARA:** Cuando instale el cierre de la cámara, asegúrese de que la posición de inicio es correcta antes de que inserte el quickfit conector.

**DE\_CAM-LOCK:** Achten Sie bei der Montage des Cam-Locks auf die richtige Ausgangsposition, bevor Sie den Quickfit einsetzen.

**IT\_BLOCCAGGIO A CAMMA:** Quando si monta il bloccaggio a camma, assicurarsi che la posizione iniziale sia corretta prima di inserire il montaggio rapido di collegamento.

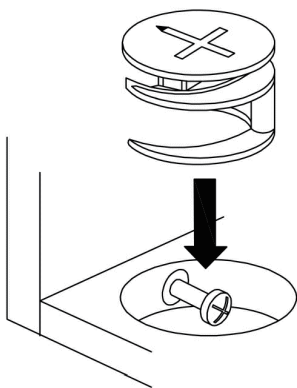

**EN\_Quickfit head** should be in the centre of the cam lock when the two panels are joined.

Cam lock should be inserted before quickfit.

**FR\_**Lorsque les deux panneaux sont assemblés, la tête du raccord rapide doit reposer au centre de la serrure batteuse.

Il faut insérer la serrure batteuse avant le raccord rapide.

**ES\_**El cabezal del quickfit debe estar en el centro del cierre de la cámara cuando se unan los dos paneles.

Se debe insertar el cierre de la cámara antes que el quickfit.

**DE\_**Der Quickfit-Kopf sollte sich in der Mitte des Cam-Locks befinden, wenn die beiden Platten zusammengefügt sind.

Der Cam-Lock sollte vor dem Quickfit eingesetzt werden.

**IT\_**La testa del montaggio rapido deve trovarsi al centro del bloccaggio a camma quando i due pannelli sono uniti.

Il Bloccaggio a Camma deve essere inserito prima del montaggio rapido.

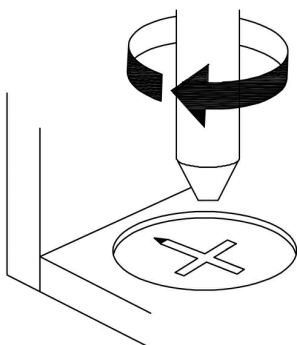

**EN\_**Turn cam lock clockwise to tighten.

**FR\_**Faites tourner la serrure batteuse dans le sens des aiguilles d'une montre pour la resserrer.

**ES\_**Gire el cierre de la cámara en sentido horario para apretarlo.

**DE\_**Drehen Sie den Cam-Lock im Uhrzeigersinn, um ihn festzuziehen.

**IT\_**Ruotare il bloccaggio a camma in senso orario per stringere.

Warnung
1. Die maximale Tragfähigkeit der Produktoberplatte beträgt 60 kg. Überlastung vermeiden.
2. Bitte Kinder nicht auf das Möbel klettern lassen, da dies zu Umkippen und schweren Verletzungen führen kann.
3. Zur Sicherheit bitte die Anweisungen korrekt befolgen und gegebenenfalls professionelle Hilfe in Anspruch nehmen.
4. Das Möbel nicht in der Nähe von Hitzequellen oder heißen Gegenständen platzieren, um Brandgefahr zu vermeiden.
5. Das Möbel nicht in feuchten Umgebungen aufstellen, um Schäden am Material zu vermeiden.
6. Regelmäßige Überprüfung aller Verbindungsstücke und Befestigungen, um sicherzustellen, dass sie fest sitzen und unerwartete Unfälle zu verhindern.
7. Das Produkt ist mit einem Kippschutz ausgestattet, um Verletzungen durch Umkippen zu verhindern.

Warning
1 The maximum load-bearing capacity of the product top panel is 60 kg. Do not overload.
2 Please do not allow children to climb on furniture, as this may result in tipping and serious injuries.
3 For safety, please follow the instructions correctly and seek professional assistance if necessary.
4 Do not place furniture near heat sources or hot items to avoid the risk of fire.
5 Do not place furniture in damp environments to prevent material damage.
6 Regularly check all fittings and fastenings to ensure they are secure and to prevent accidents.
7 This product comes with an anti-tip device to prevent injuries from tipping.

Avertissement
1 La capacité de charge maximale du plateau supérieur du produit est de 60 kg. Ne pas surcharger.
2 Veuillez ne pas laisser les enfants grimper sur les meubles, car cela peut entraîner un basculement et des blessures
3 Pour des raisons de sécurité, veuillez suivre correctement les instructions et demander de l'aide professionnelle si nécessaire.
4 Ne pas placer les meubles près de sources de chaleur ou d'objets chauds pour éviter tout risque d'incendie.
5 Ne pas placer les meubles dans des environnements humides pour éviter les dommages matériels.
6 Vérifiez régulièrement tous les raccords et fixations pour vous assurer qu'ils sont bien serrés et pour éviter les accidents.
7 Ce produit est équipé d'un dispositif anti-basculement pour éviter les blessures en cas de basculement.

Avviso
1 La capacità massima di carico del piano superiore del prodotto è di 60 kg. Non sovraccaricare.
2 Si prega di non permettere ai bambini di arrampicarsi sui mobili, poiché ciò potrebbe causare il ribaltamento e gravi lesioni.
3 Per motivi di sicurezza, seguire correttamente le istruzioni e richiedere assistenza professionale se necessario.
4 Non posizionare i mobili vicino a fonti di calore o oggetti caldi per evitare il rischio di incendio.
5 Non posizionare i mobili in ambienti umidi per evitare danni al materiale.
6 Controllare regolarmente tutti i raccordi e i fissaggi per assicurarsi che siano saldi e per evitare incidenti.
7 Questo prodotto è dotato di un dispositivo anti-ribaltamento per evitare lesioni dovute al ribaltamento.

Aviso
1 La capacidad máxima de carga del panel superior del producto es de 60 kg. No sobrecargar.
2 Por favor, no permita que los niños trepen sobre los muebles, ya que esto podría provocar que se vuelquen y causar lesiones graves.
3 Por seguridad, siga correctamente las instrucciones y solicite ayuda profesional si es necesario.
4 No coloque los muebles cerca de fuentes de calor o objetos calientes para evitar el riesgo de incendio.
5 No coloque los muebles en entornos húmedos para evitar daños en el material.
6 Revise regularmente todas las conexiones y sujeciones para asegurarse de que estén firmes y para evitar accidentes.
7 Este producto viene con un dispositivo antivuelco para evitar lesiones por vuelco.

## •Components - fittings

Please check you have all the panels listed below.

Note: The quantitie below are the correct amount to complete the assembly. In some cases more fittings may be supplied than are required.

## •Komponenten Verschraubungen

Bitte überprüfen Sie, ob Sie alle unten aufgeführten Panels haben.

Hinweis: Die folgende Menge ist die richtige Menge, um die Montage abzuschließen. In einigen Fällen können mehr Armaturen geliefert werden, als erforderlich.

## •Composants - accessoires

Veuillez vérifier que vous possédez tous les panneaux énumérés ci - dessous.

Remarque: les quantités ci - dessous sont les quantités correspondantes nécessaires pour terminer l'assemblage. Dans certains cas, plus d'accessoires que nécessaire peuvent être fournis.

N620P206331- Box:1/2

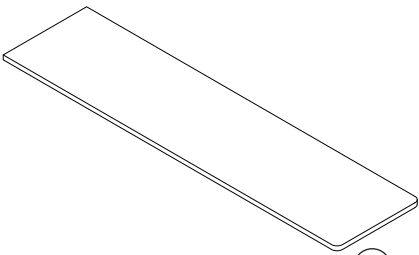
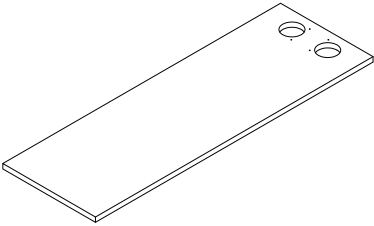
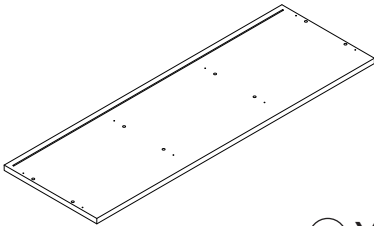
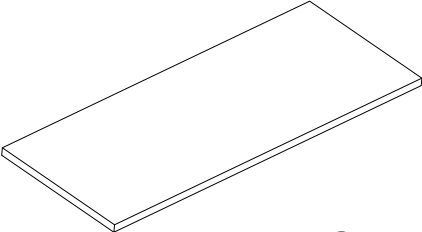
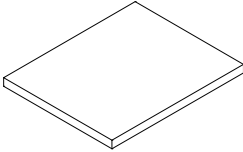
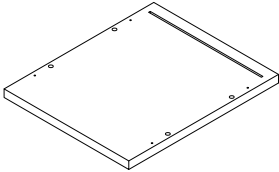
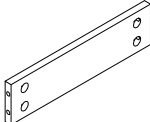
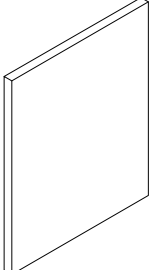
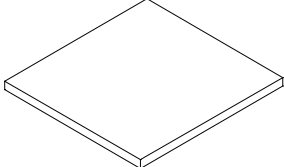
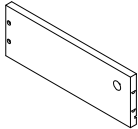
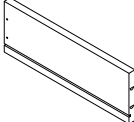
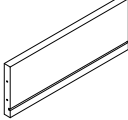
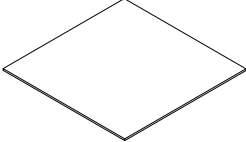
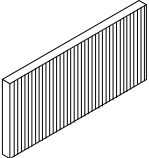
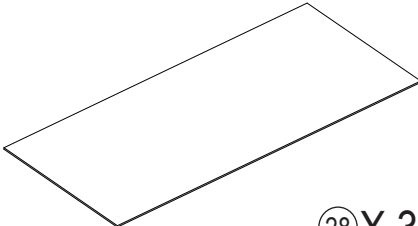
 ① X 1	 ② X 1	 ③ X 1
 ⑧ X 2	 ⑬ X 1	 ⑭ X 1
 ⑮ X 2	 ⑲ X 1	 ⑳ X 2
 ㉒ X 1	 ㉓ X 1	 ㉔ X 1
 ㉕ X 1	 ㉖ X 1	 ㉘ X 3

N620P206332 - Box:2/2

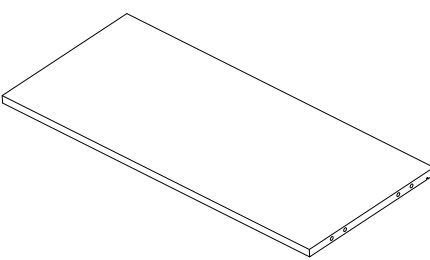
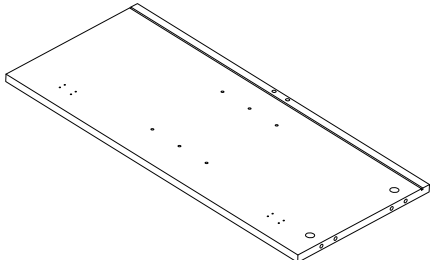
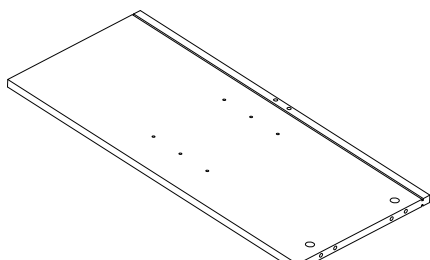
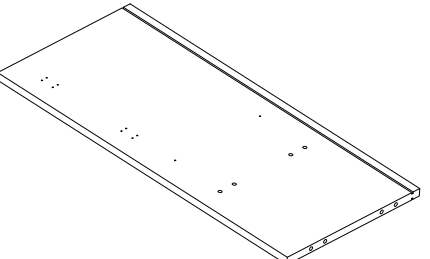
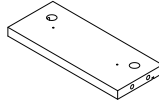
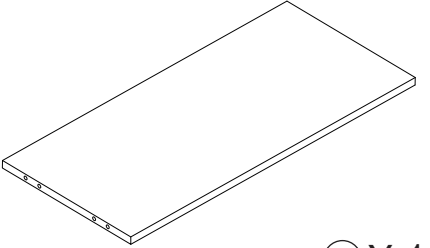
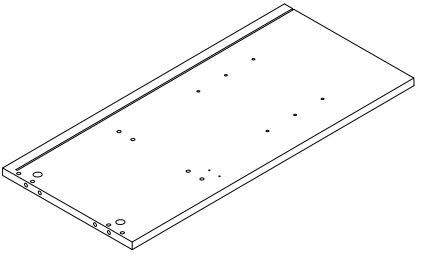
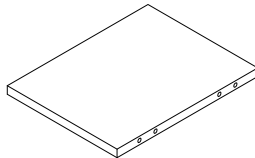
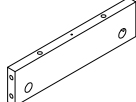
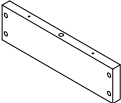
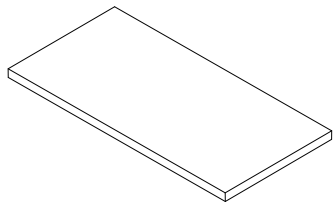
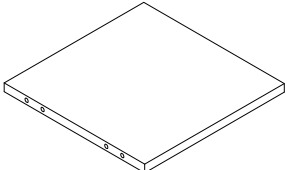
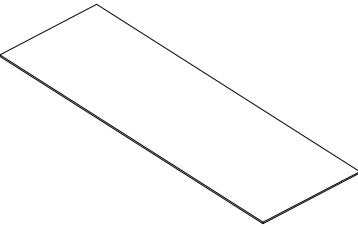
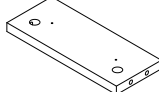
 <p>④ X 1</p>	 <p>⑤ X 1</p>	 <p>⑥ X 1</p>
 <p>⑦ X 1</p>	 <p>⑨ X 1</p>	 <p>⑩ X 1</p>
 <p>⑪ X 1</p>	 <p>⑫ X 1</p>	 <p>⑯ X 2</p>
 <p>⑰ X 2</p>	 <p>⑱ X 1</p>	 <p>⑳ X 1</p>
 <p>㉑ X 1</p>	 <p>㉒ X 1</p>	

## ·Components - fittings

Please check you have all the panels listed below.

Note: The quantitie below are the correct amount to complete the assembly. In some cases more fittings may be supplied than are required.

## ·Komponenten Verschraubungen

Bitte überprüfen Sie, ob Sie alle unten aufgeführten Panels haben.









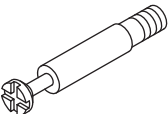

Hinweis: Die folgende Menge ist die richtige Menge, um die Montage abzuschließen. In einigen Fällen können mehr Armaturen geliefert werden, als erforderlich.

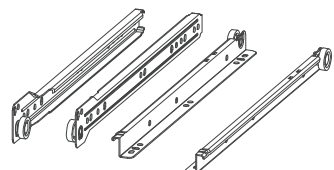

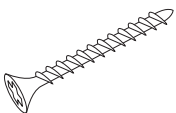
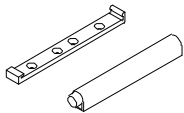
## ·Composants - accessoires

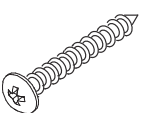
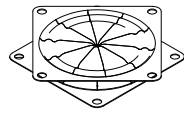
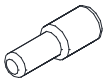
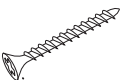
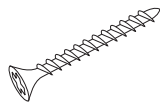
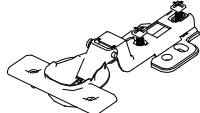
Veillez vérifier que vous possédez tous les panneaux énumérés ci - dessous.

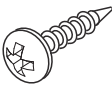
Remarque: les quantités ci - dessous sont les quantités correspondantes nécessaires pour terminer l'assemblage. Dans certains cas, plus d'accessoires que nécessaire peuvent être fournis.

Hardware-Liste :Box:1

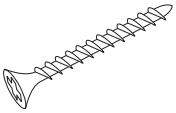
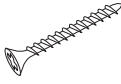
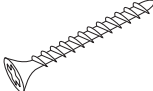
 M6x35mm	 Φ15x9mm	 Φ6x30mm	
<b>A x 38pcs</b>	<b>B x 38pcs</b>	<b>C x 48pcs</b>	<b>D x 1 pcs</b>
 M3.5x12mm	 M4x35mm		
<b>E x 8pcs</b>	<b>F x 12pcs</b>	<b>G x 5pcs</b>	<b>H x 10pcs</b>
 M4x50mm			 M4x25mm
<b>I x 6 pcs</b>	<b>J x 1pc</b>	<b>K x 12pcs</b>	<b>L x 4pcs</b>
 M4x30mm		 M4x14mm	 M4x14mm
<b>M x 4 pcs</b>	<b>Nx 8pcs</b>	<b>O x 48pcs</b>	<b>P x 8pcs</b>
 M3x12mm			
<b>Q x 10pcs</b>			

 M3.5x12mm	 M4x35mm	 M4x25mm	 M4x30mm
<b>E x 8pcs</b>	<b>F x 12pcs</b>	<b>L x 4pcs</b>	<b>M x 4 pcs</b>
 M4x14mm	 M3x12mm		
<b>O x 48pcs</b>	<b>Q x 10pcs</b>		

DE:Bitte beachten Sie, dass die Formen der Schrauben E und F und L und M und O und Q ähnlich sind. Bitte installieren Sie entsprechend der Anleitung und unterscheiden Sie sie! Sie sie!

UK:Please note that the shapes of screws E and F and L and M and O and Q are similar. please install according to the instructions and distinguish them!

FR:Notez que les vis E et F et L et M et O et Q ont des formes similaires. Veuillez les installer en suivant les instructions pour les séparer!

IT: Si prega di notare che le forme delle viti A, B e C sono simili. Si prega di installarle seguendo le istruzioni e di distinguerle!

ES: Por favor, tenga en cuenta que las formas de los tornillos A, B y C son similares. Por favor, instálelos de acuerdo con las instrucciones y distíngalos.

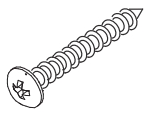
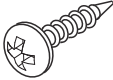
 M4x50mm	 M4x14mm
<b>I x 6 pcs</b>	<b>P x 8pcs</b>

DE:Bitte beachten Sie, dass die Formen der Schrauben E und F und L und M und O und Q ähnlich sind. Bitte installieren Sie entsprechend der Anleitung und unterscheiden Sie sie! Sie sie!

UK:Please note that the shapes of screws E and F and L and M and O and Q are similar. please install according to the instructions and distinguish them!

FR:Notez que les vis E et F et L et M et O et Q ont des formes similaires. Veuillez les installer en suivant les instructions pour les séparer!

IT: Si prega di notare che le forme delle viti A, B e C sono simili. Si prega di installarle seguendo le istruzioni e di distinguerle!

ES: Por favor, tenga en cuenta que las formas de los tornillos A, B y C son similares. Por favor, instálelos de acuerdo con las instrucciones y distíngalos.

# Installationsanleitung/Installation Instruction/Instruction d'installation Istruzioni di installazione/Instrucciones de instalación

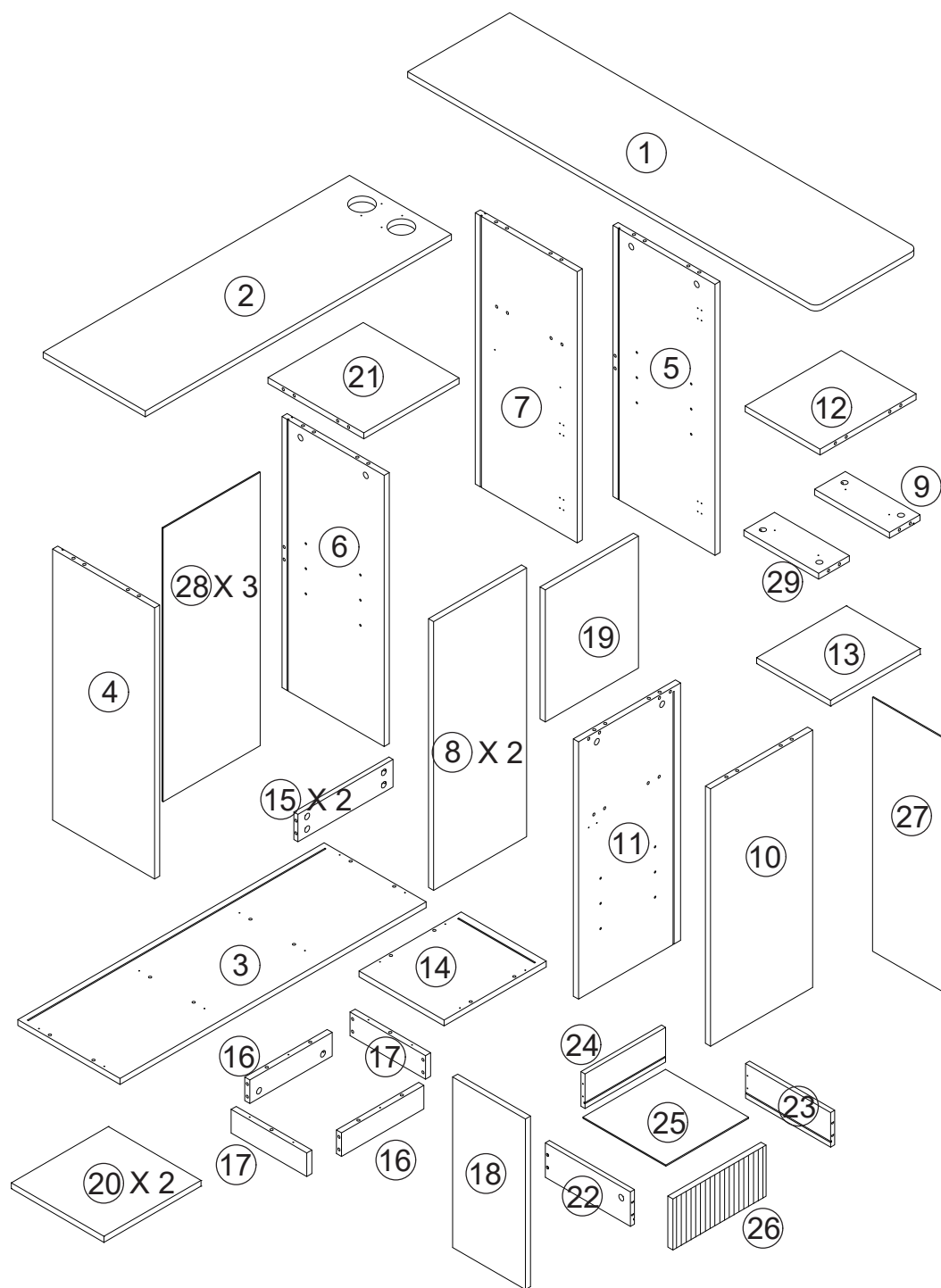

<b>Importeur</b>	Decobus Handel GmbH		
<b>Adresse</b>	Innungsstraße 9, 21244 Buchholz, Deutschland		
<b>URL</b>	<a href="https://www.decobusgroup.de">https://www.decobusgroup.de</a>		
<b>Hersteller</b>	FUJIAN YILUSHUN HOME PRODUCTS CO., LTD		
<b>Adresse</b>	INSIDE OF FUZHOU XINGANG RONGMEI STORAGE CO.,LTD,JIANGYIN INDUSTRIAL CONCENTRATION ZONE,FUQING CITY,FUZHOU,FUJIAN SHENG,CHINA		
<b>Email/URL</b>	admin@fjyilushun.com		
<table border="1"> <tr> <td><b>EC</b></td> <td><b>REP</b></td> </tr> </table>	<b>EC</b>	<b>REP</b>	Decobus Handel GmbH
	<b>EC</b>	<b>REP</b>	
Innungsstraße 9, 21244 Buchholz, Deutschland <a href="https://www.decobusgroup.de">https://www.decobusgroup.de</a>			



# Installationsanleitung/Installation Instruction/Instruction d'installation Istruzioni di installazione/Instrucciones de instalación

## STEP 1/SCHRITT 1/Étapes 1/Passo 1/Paso 1

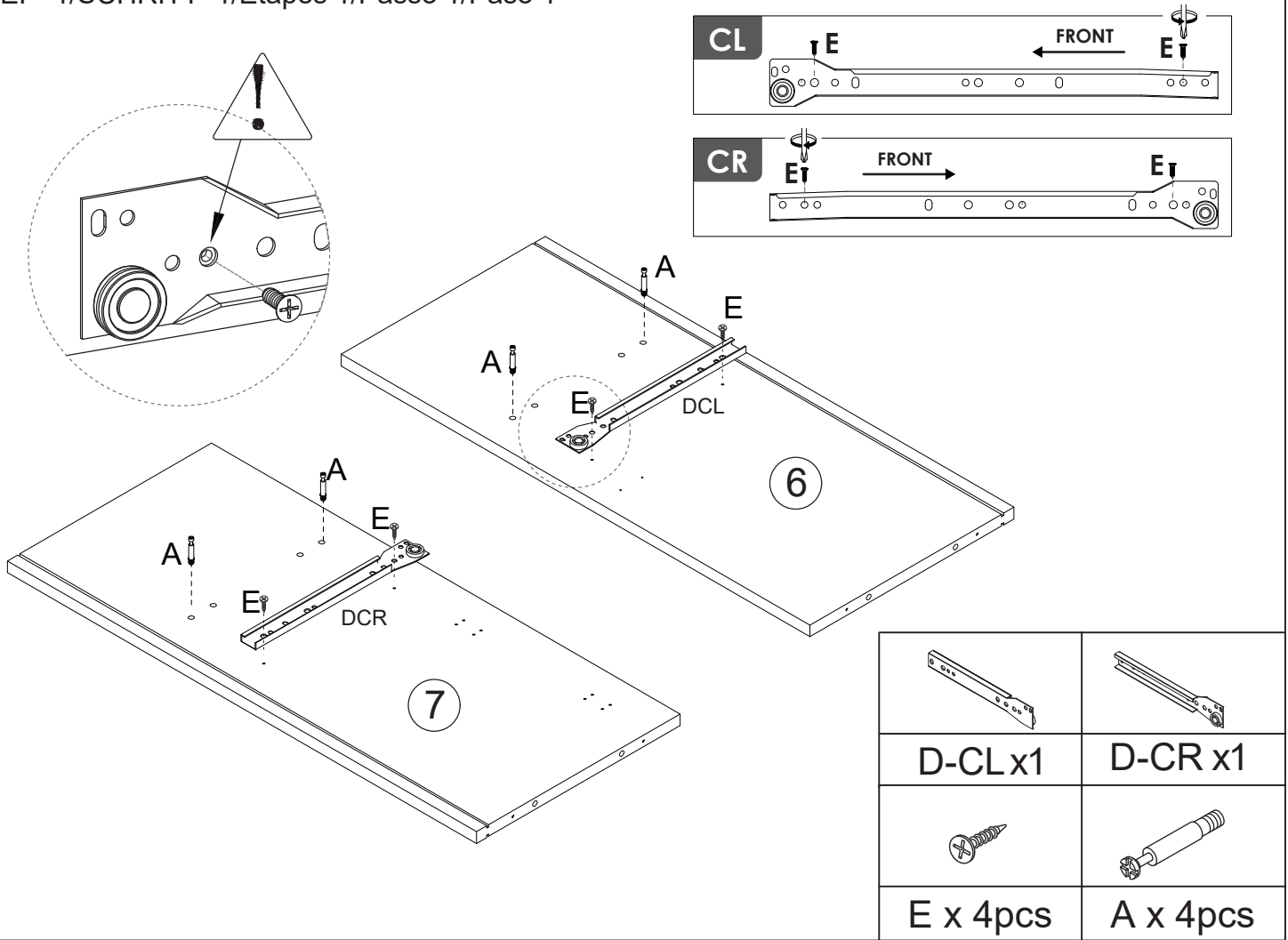

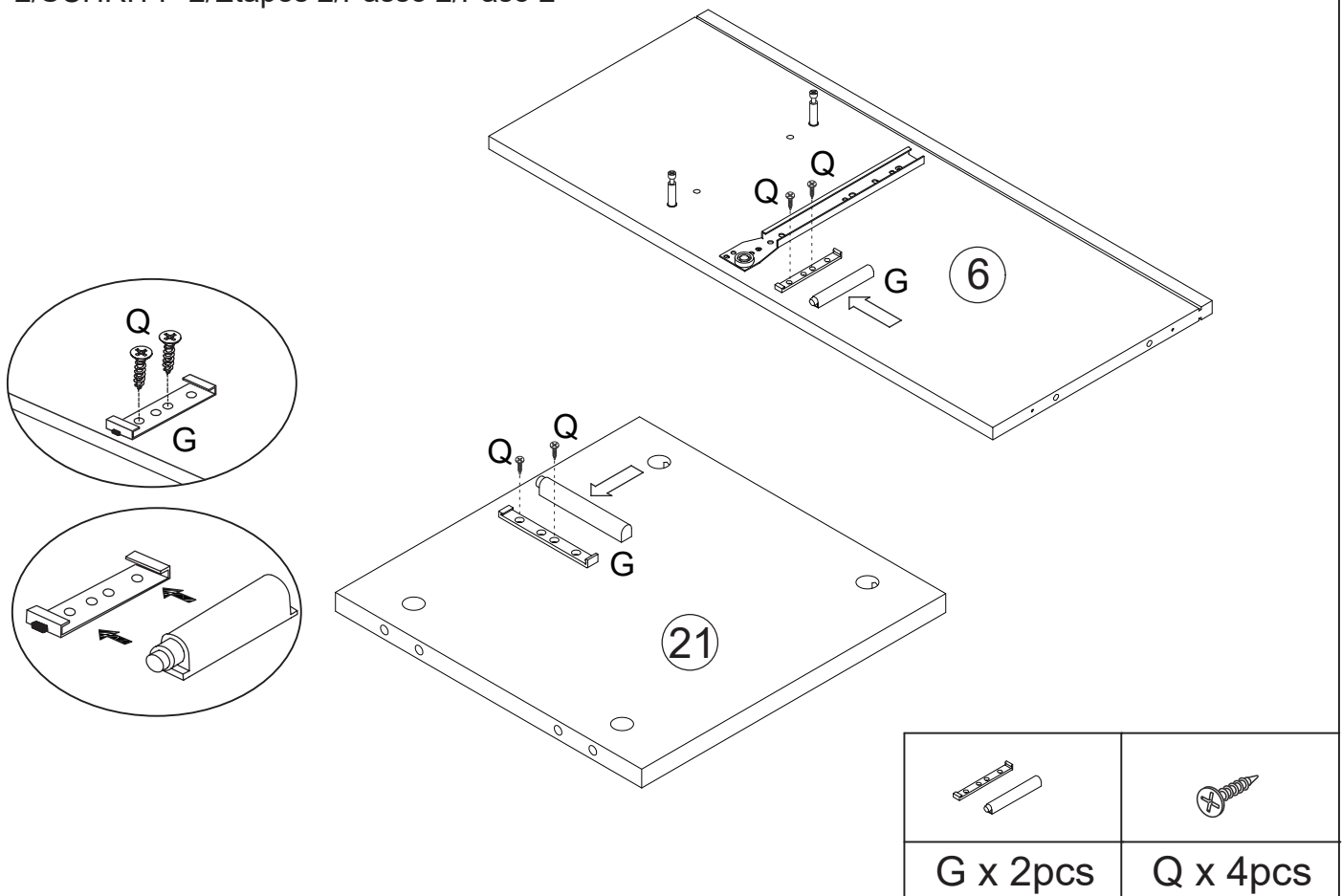

## STEP 2/SCHRITT 2/Étapes 2/Passo 2/Paso 2

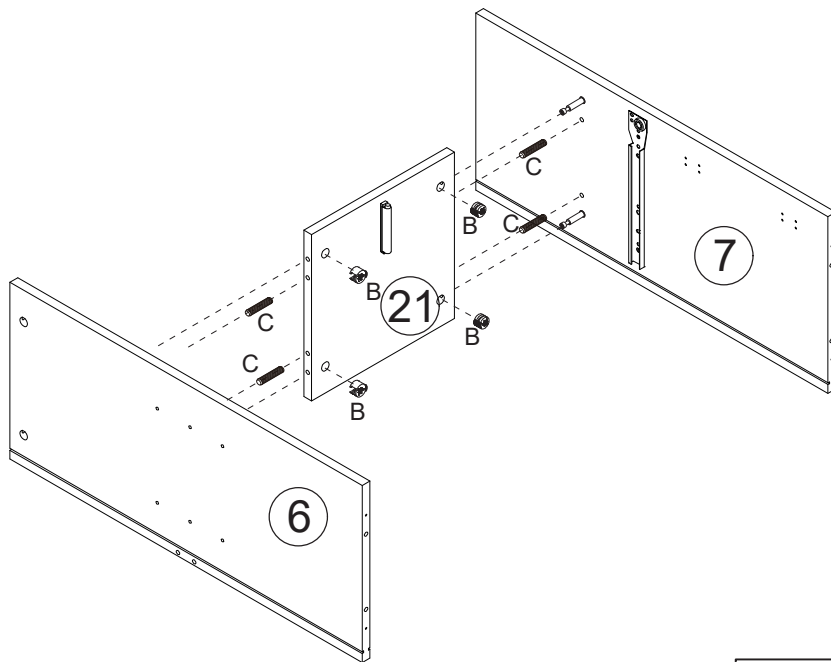

# Installationsanleitung/Installation Instruction/Instruction d'installation Istruzioni di installazione/Instrucciones de instalación

STEP 3/SCHRITT 3/Étapes 3/Passo 3/Paso 3



	
B x 4pcs	C x 4pcs

STEP 4/SCHRITT 4/Étapes 4/Passo 4/Paso 4

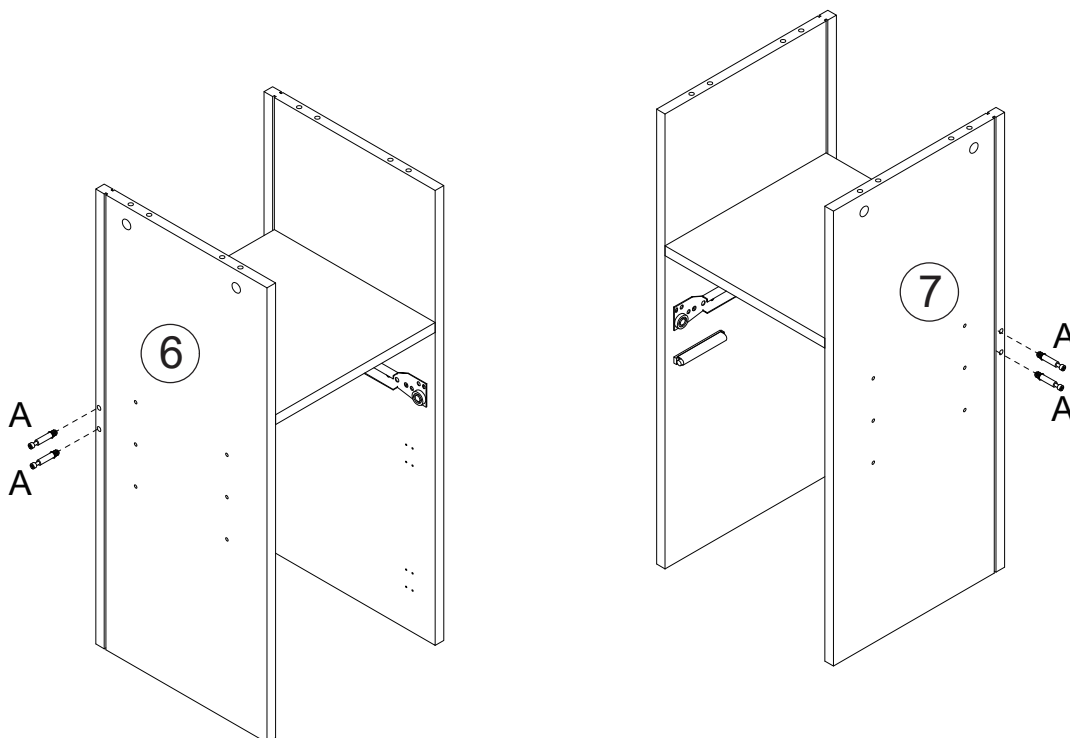

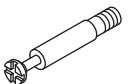
A x 4pcs

# Installationsanleitung/Installation Instruction/Instruction d'installation Istruzioni di installazione/Instrucciones de instalación

STEP 5/SCHRITT 5/Étapes 5/Passo 5/Paso 5

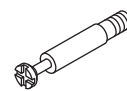
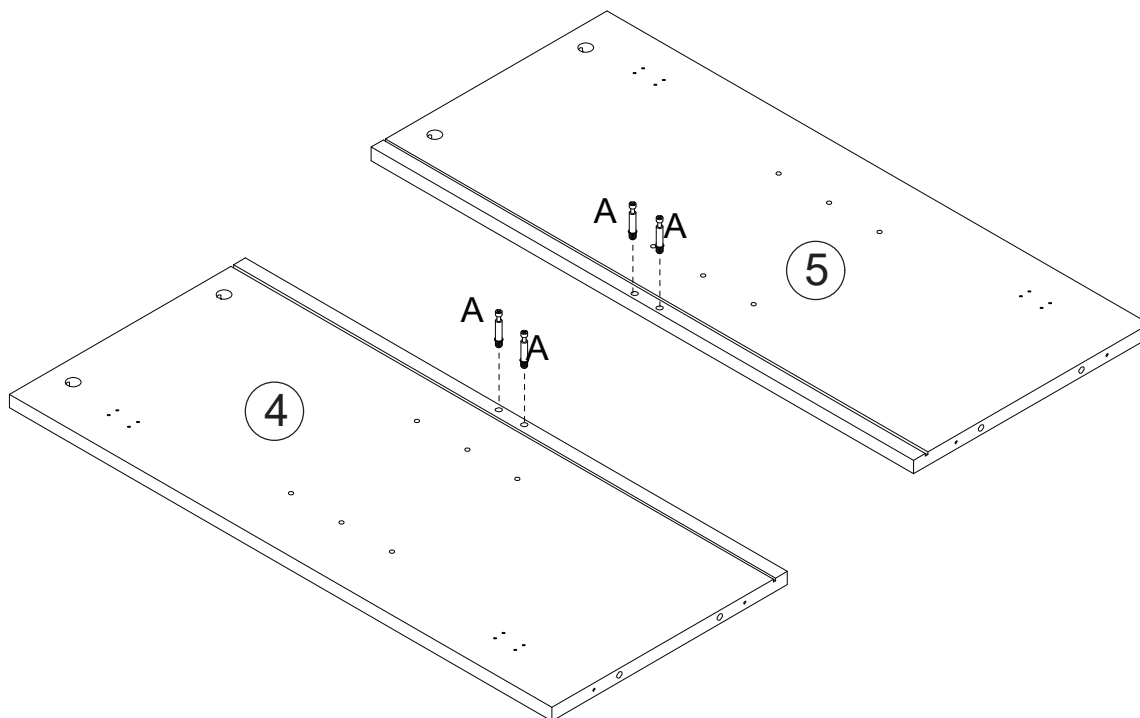

A x4pcs

STEP 6/SCHRITT 6/Étapes 6/Passo 6/Paso 6

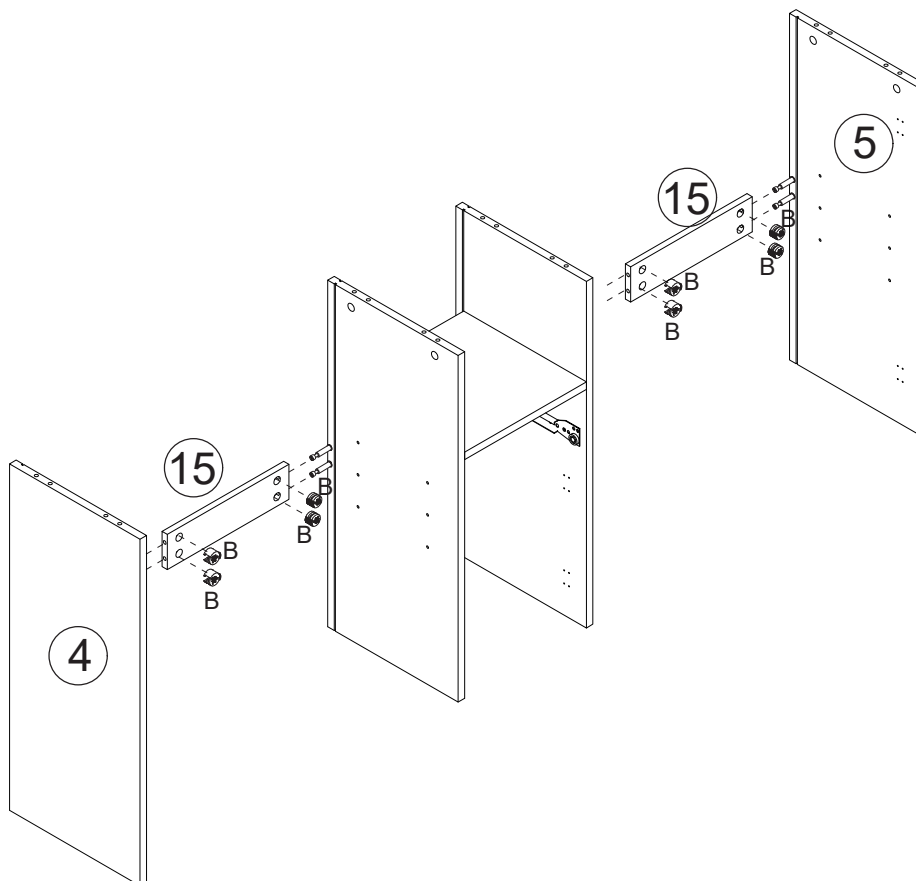



B x8pcs

# Installationsanleitung/Installation Instruction/Instruction d'installation Istruzioni di installazione/Instrucciones de instalación

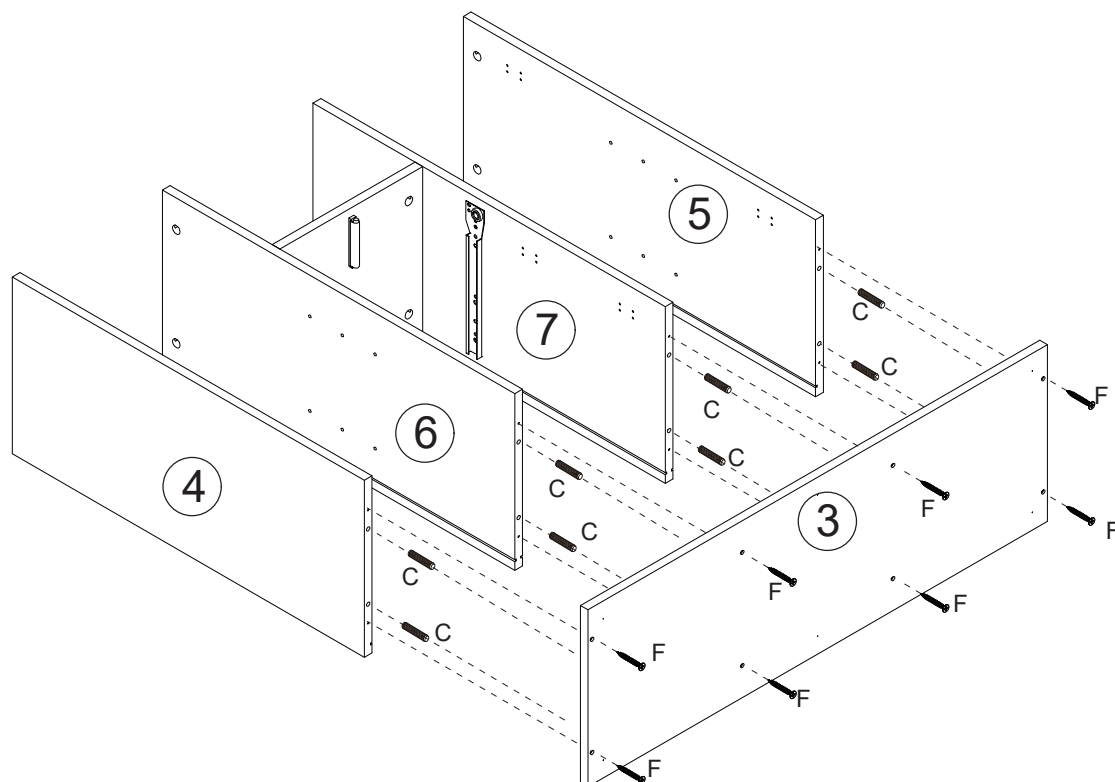
STEP 7/SCHRITT 7/Étapes 7/Passo 7/Paso 7

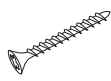

	
F x8pcs	C x8pcs

STEP 8/SCHRITT 8/Étapes 8/Passo 8/Paso 8

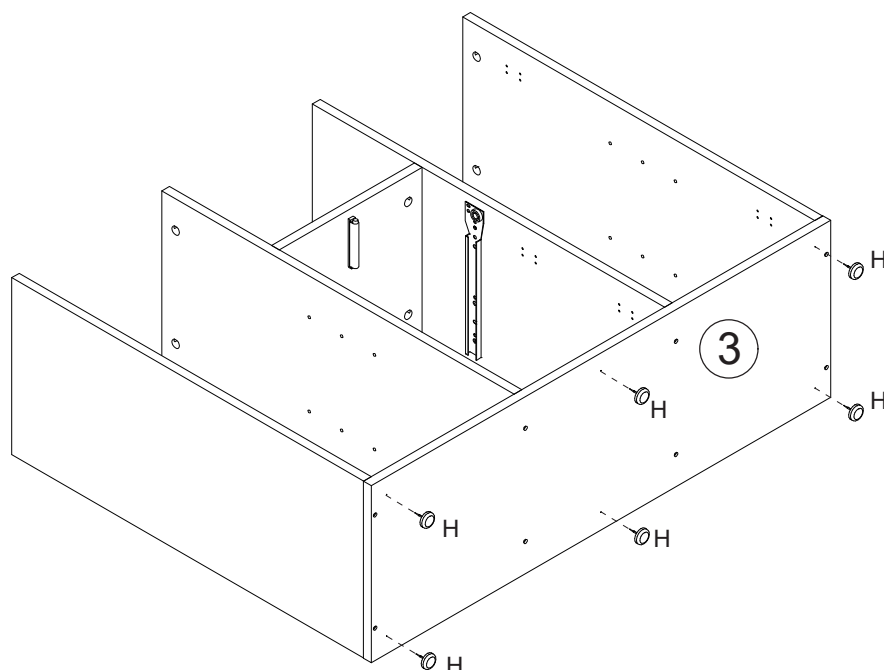



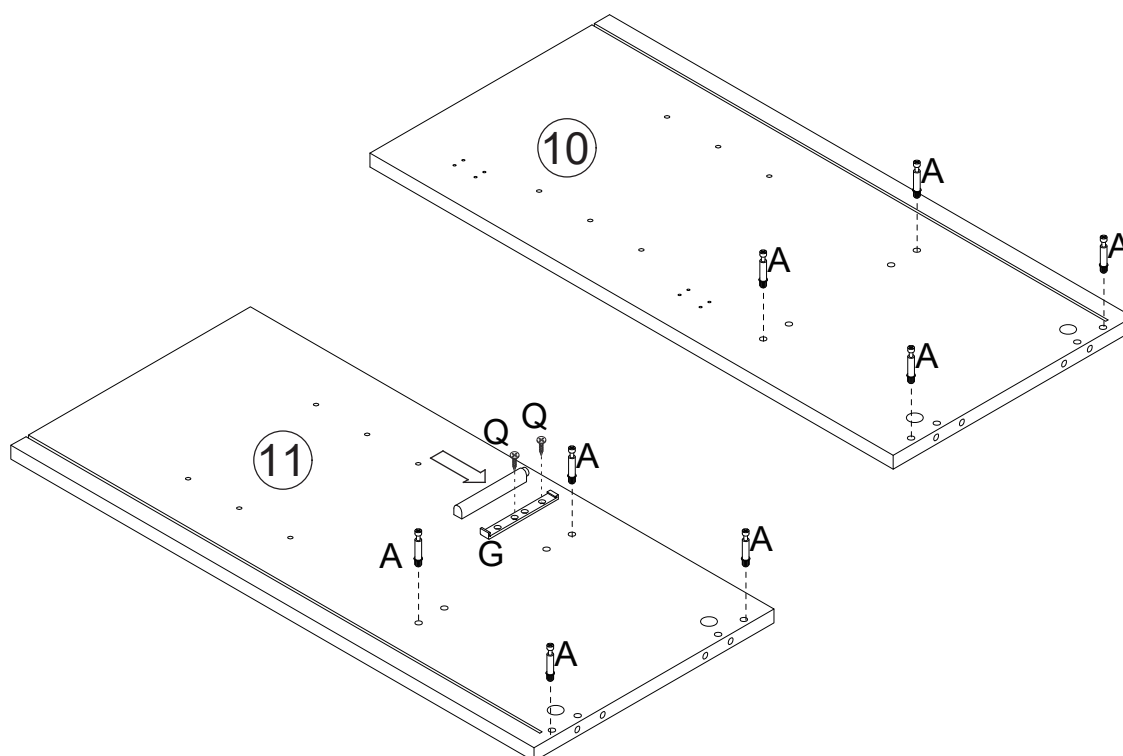

H x6pcs

# Installationsanleitung/Installation Instruction/Instruction d'installation Istruzioni di installazione/Instrucciones de instalación

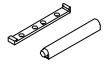

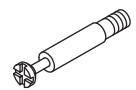
STEP 9/SCHRITT 9/Étapes 9/Passo 9/Paso 9

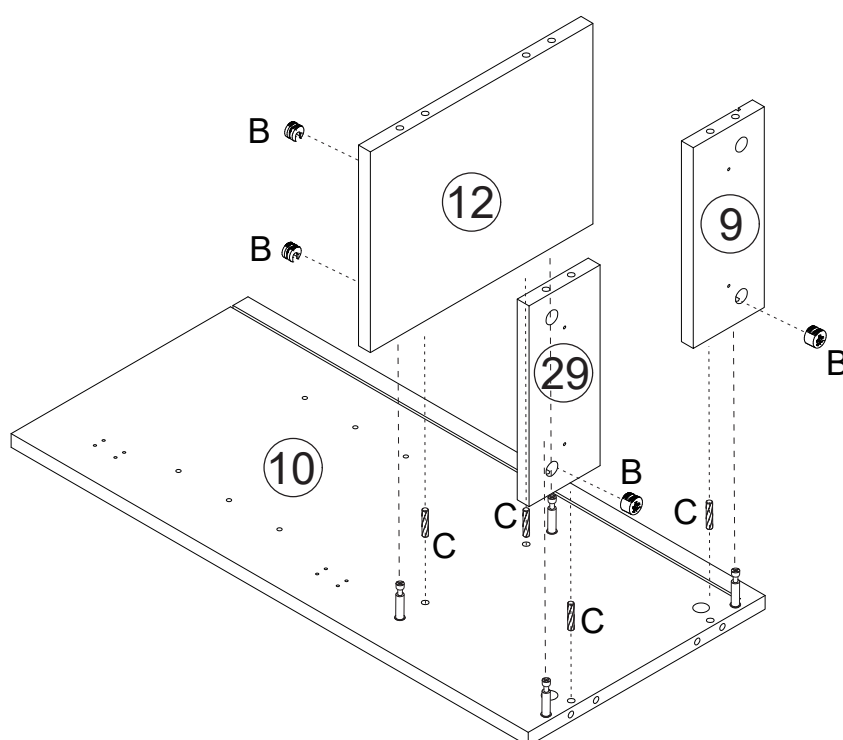

		
G x 1pc	Q x 2pcs	A x 8pcs

STEP 10/SCHRITT 10/Étapes 10/Passo 10/Paso 10





	
B x 4pcs	C x 4pcs

# Installationsanleitung/Installation Instruction/Instruction d'installation Istruzioni di installazione/Instrucciones de instalación

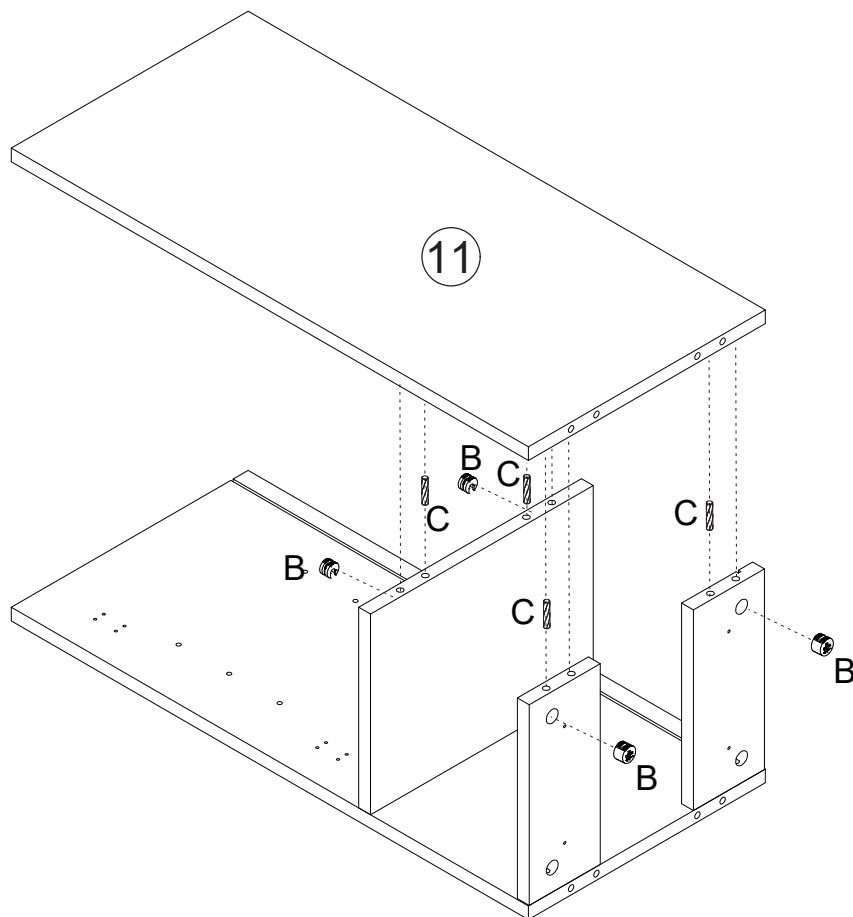

STEP 11/SCHRITT 11/Étapes 11/Passo 11/Paso 11

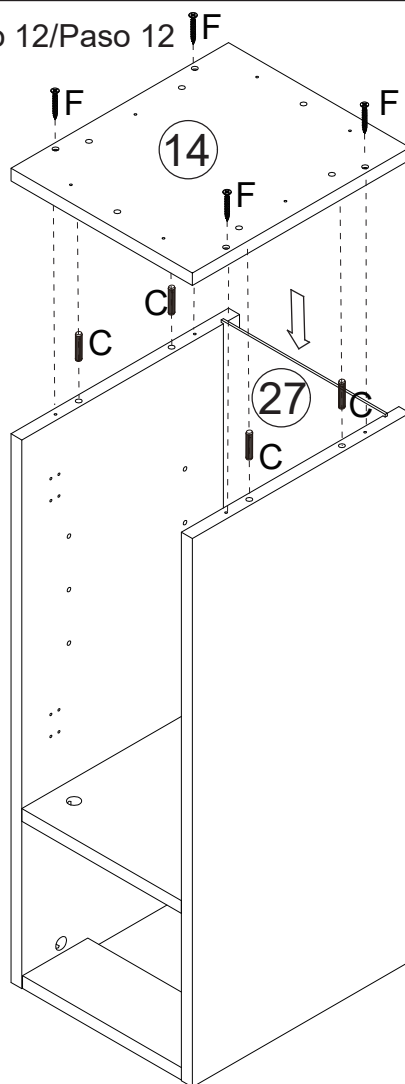

	
B x4pcs	C x4pcs

STEP 12/SCHRITT 12/Étapes 12/Passo 12/Paso 12

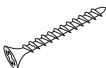



	
F x4pcs	C x4pcs

# Installationsanleitung/Installation Instruction/Instruction d'installation Istruzioni di installazione/Instrucciones de instalación

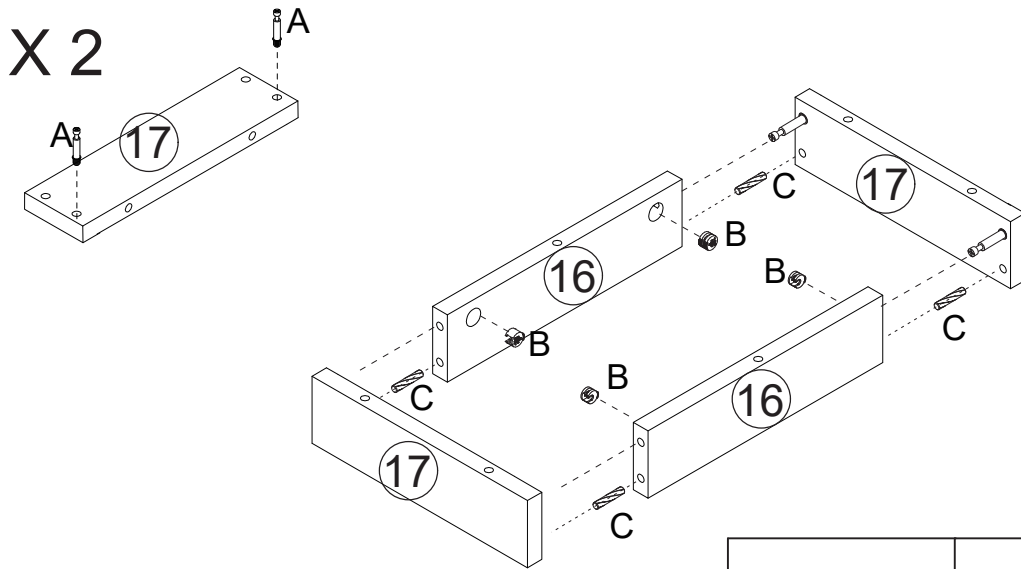

STEP 13/SCHRITT 13/Étapes 13/Passo 13/Paso 13

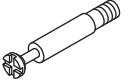

		
B x4pcs	C x4pcs	A x 4pcs

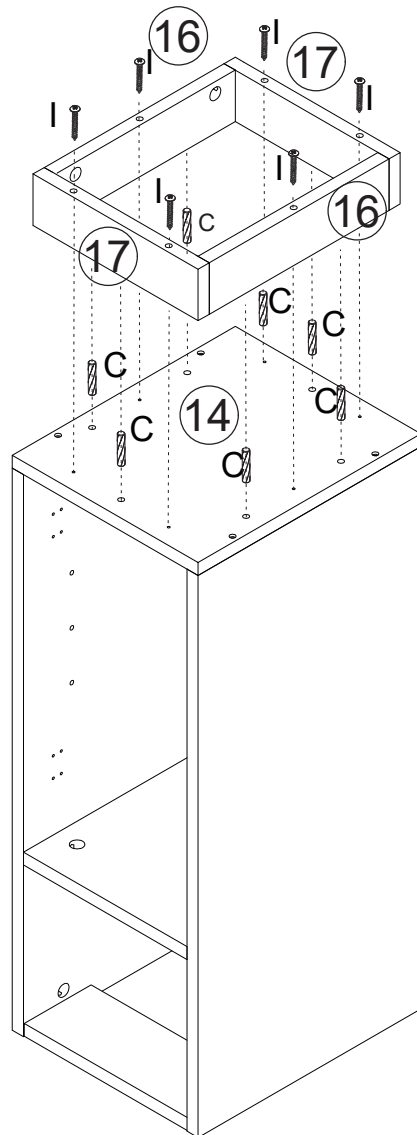
STEP 14/SCHRITT 14/Étapes 14/Passo 14/Paso 14



	
C x6pcs	I x6pcs

# Installationsanleitung/Installation Instruction/Instruction d'installation Istruzioni di installazione/Instrucciones de instalación

STEP 15/SCHRITT 15/Étapes 15/Passo 15/Paso 15

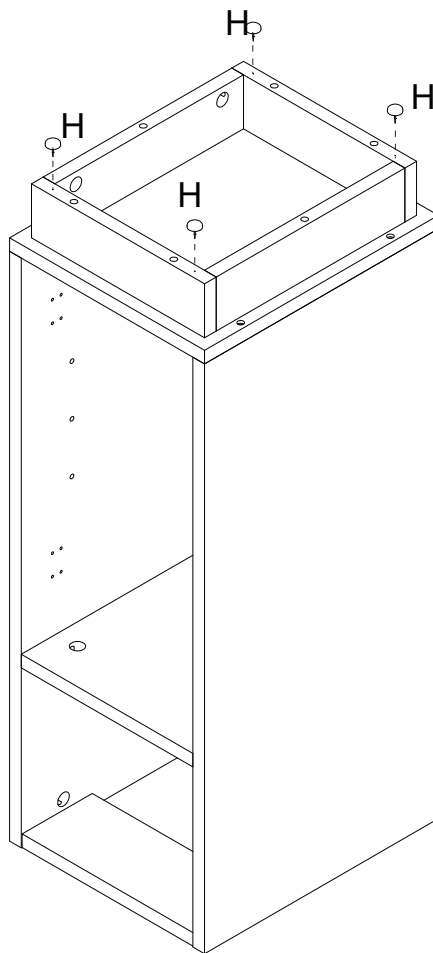

H x4pcs

STEP 16/SCHRITT 16/Étapes 16/Passo 16/Paso 16

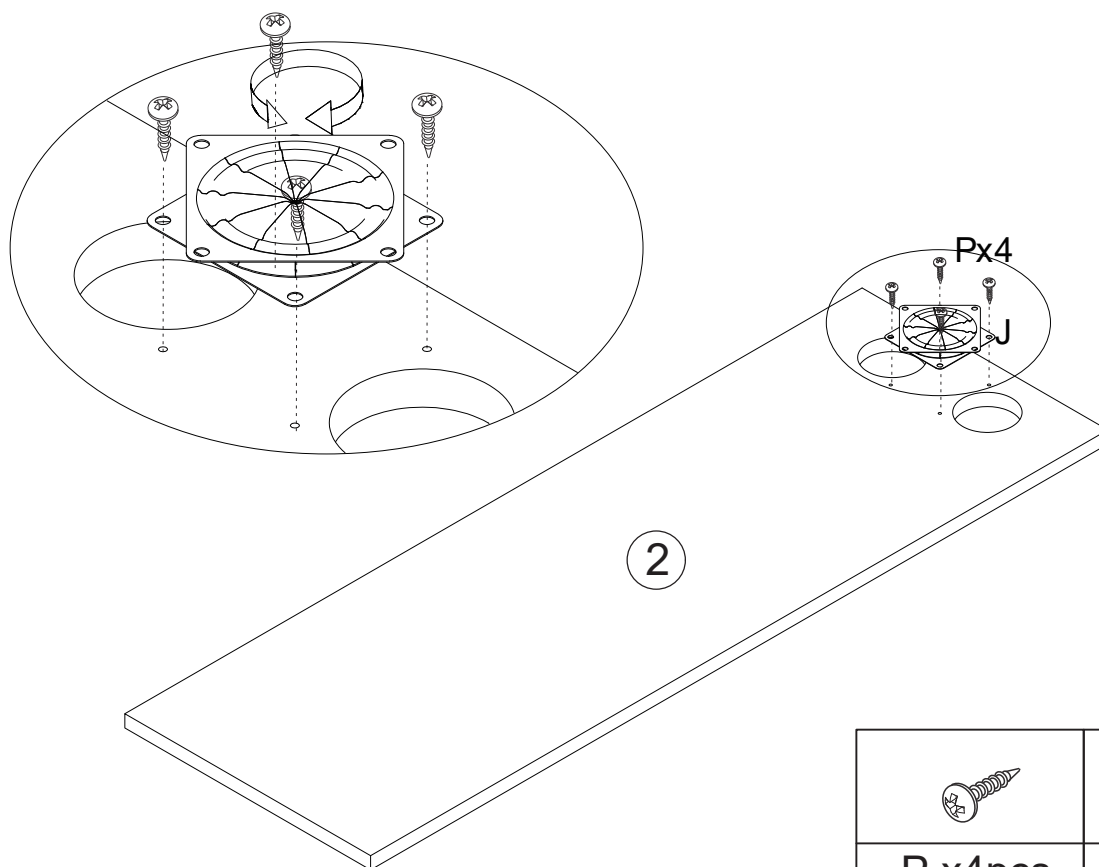

P x4pcs

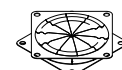

J x1pc



# Installationsanleitung/Installation Instruction/Instruction d'installation Istruzioni di installazione/Instrucciones de instalación

STEP 17/SCHRITT 17/Étapes 17/Passo 17/Paso 17

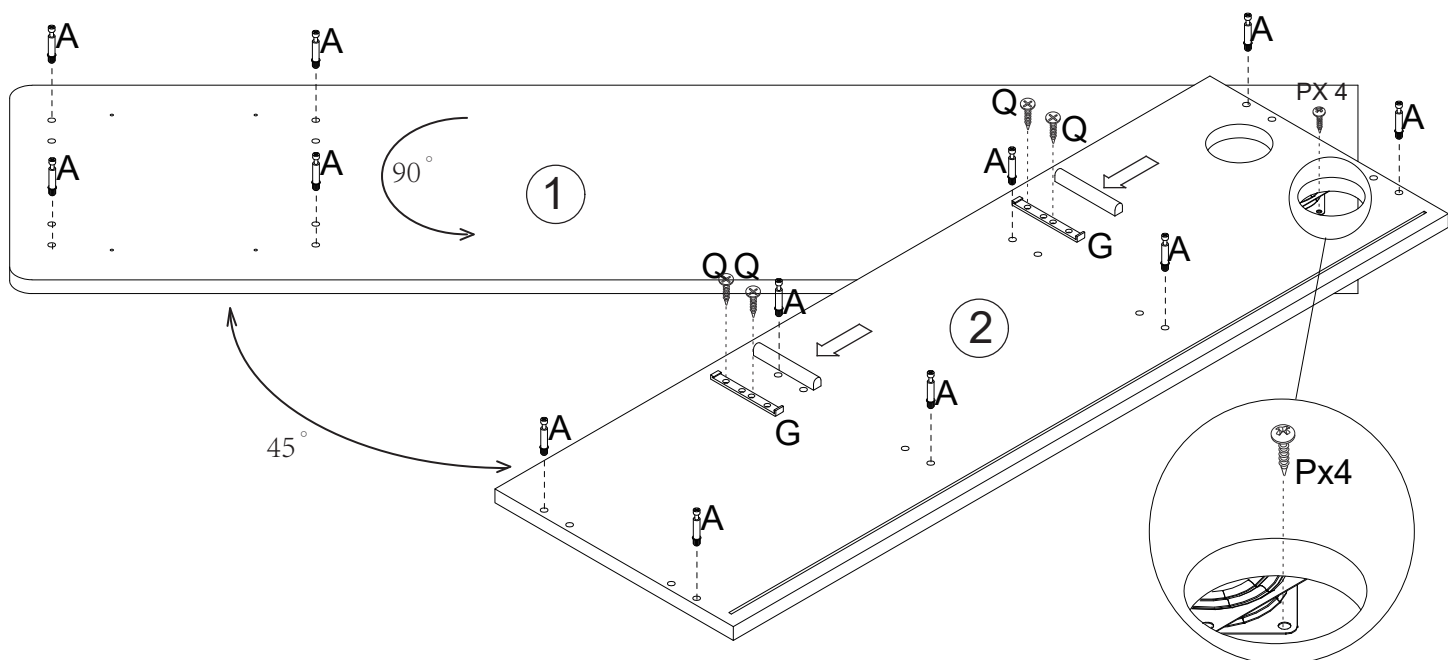

P x 4pcs	G x 2pcs	Q x 4pcs	A x 12pcs

STEP 18/SCHRITT 18/Étapes 18  
Passo 18/Paso 18

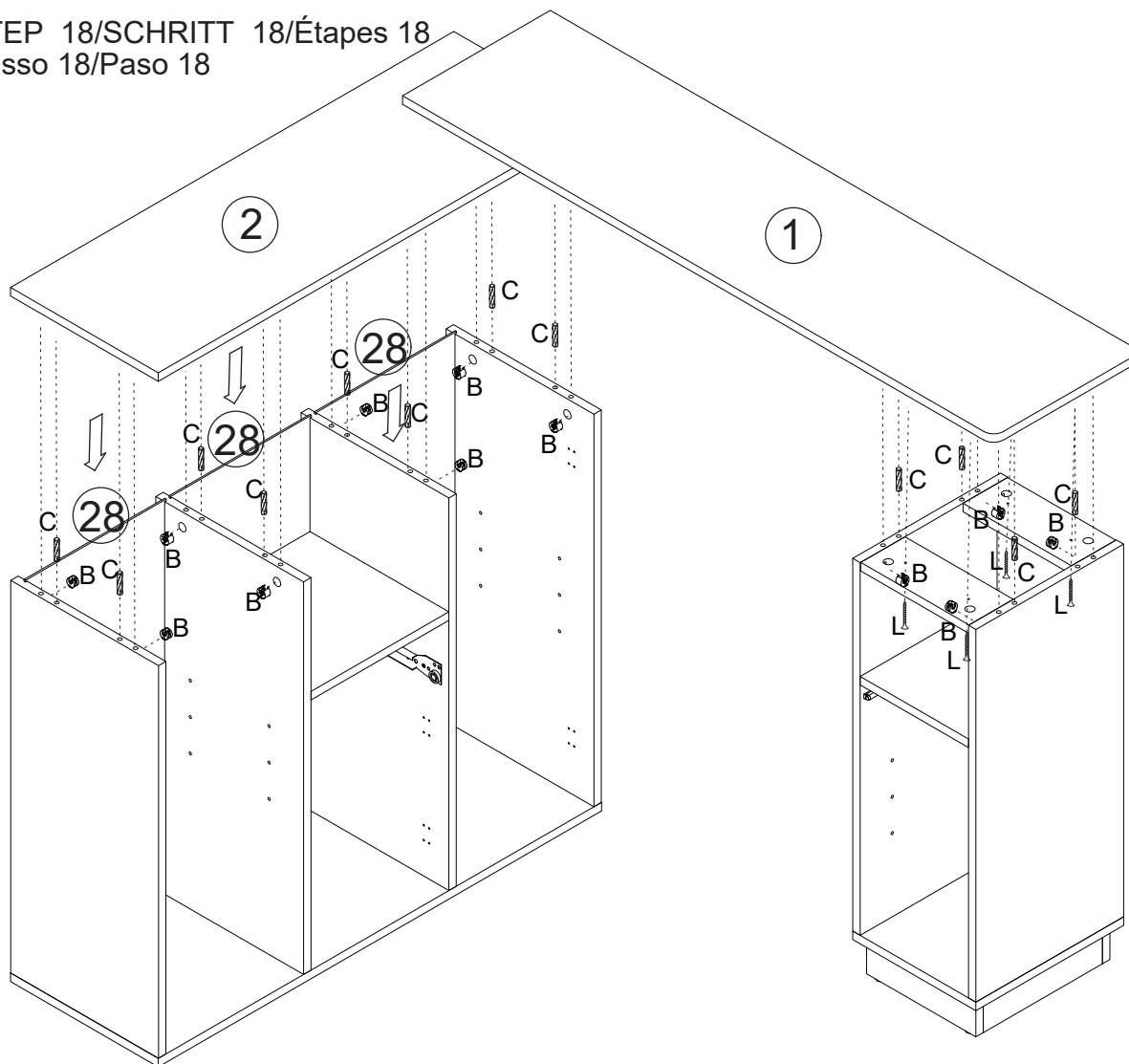

C x 12pcs
B x 12pcs
L x 4pcs

# Installationsanleitung/Installation Instruction/Instruction d'installation Istruzioni di installazione/Instrucciones de instalación

STEP 19/SCHRITT 19/Étapes 19/Passo 19/Paso 19

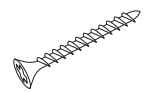
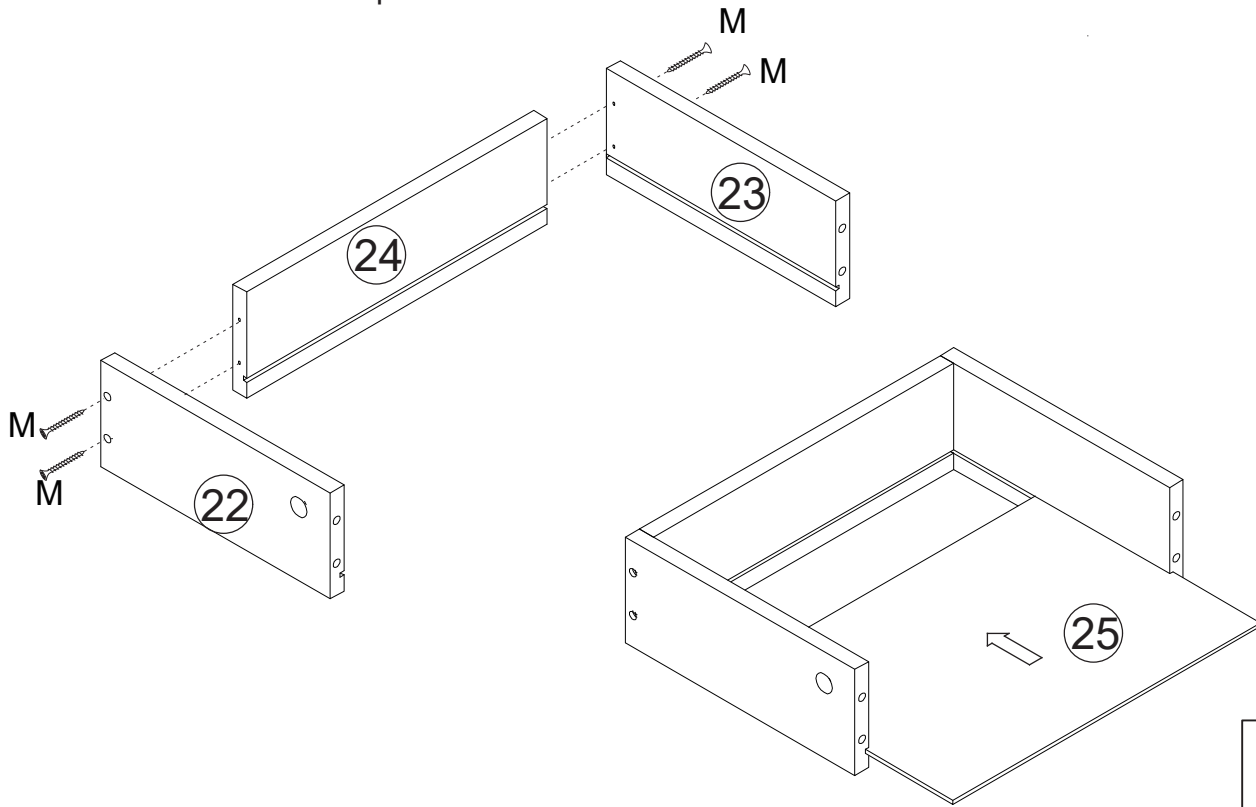

M x4pcs

STEP 20/SCHRITT 20/Étapes 20/Passo 20/Paso 20

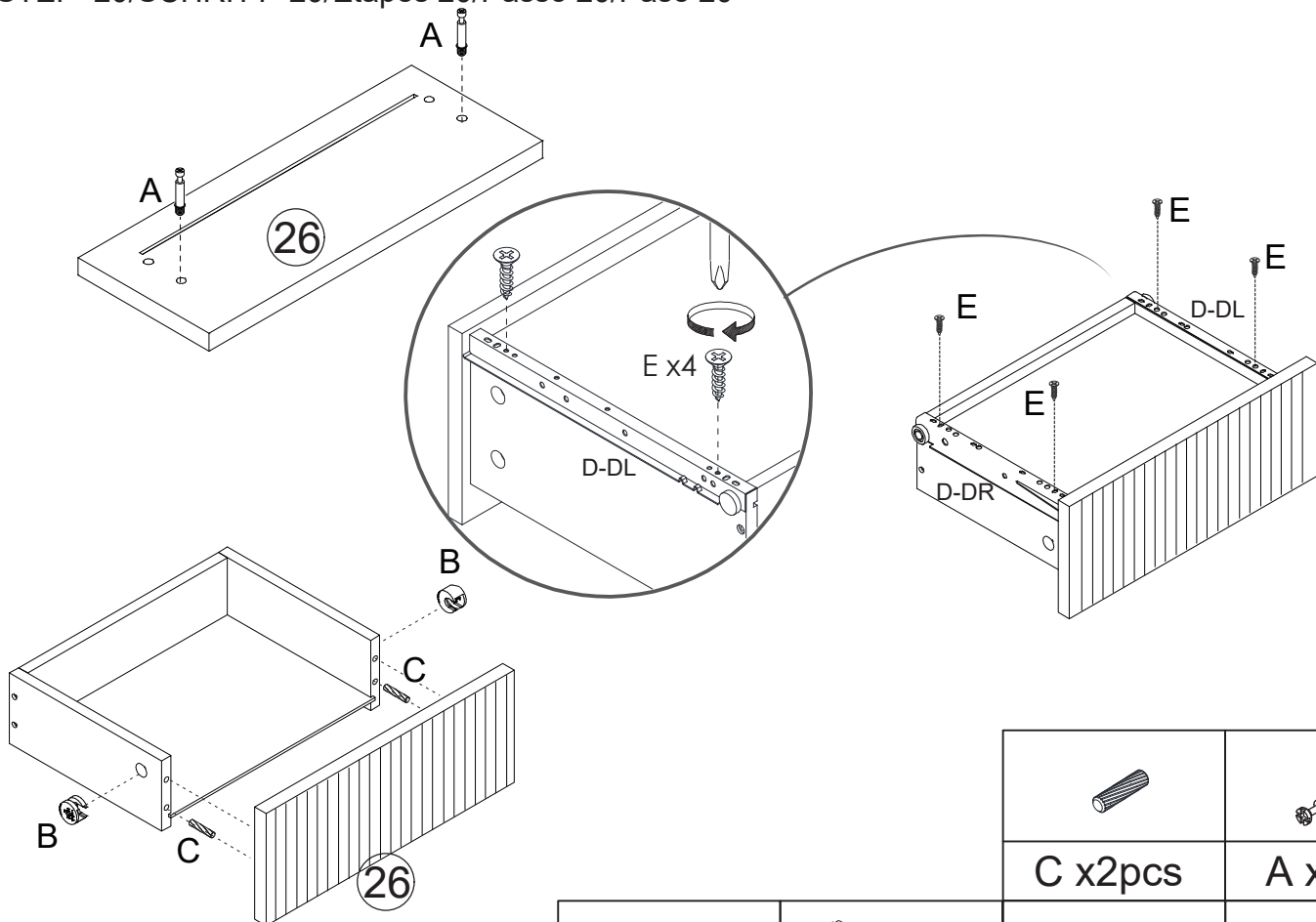

C x2pcs

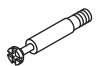

A x2pcs

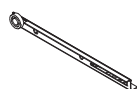

D-DL x1pc

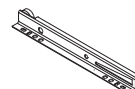

D-DR x1pc



B x2pcs



E x4pcs

# Installationsanleitung/Installation Instruction/Instruction d'installation Istruzioni di installazione/Instrucciones de instalación

STEP 21/SCHRITT 21/Étapes 21/Passo 21/Paso 21

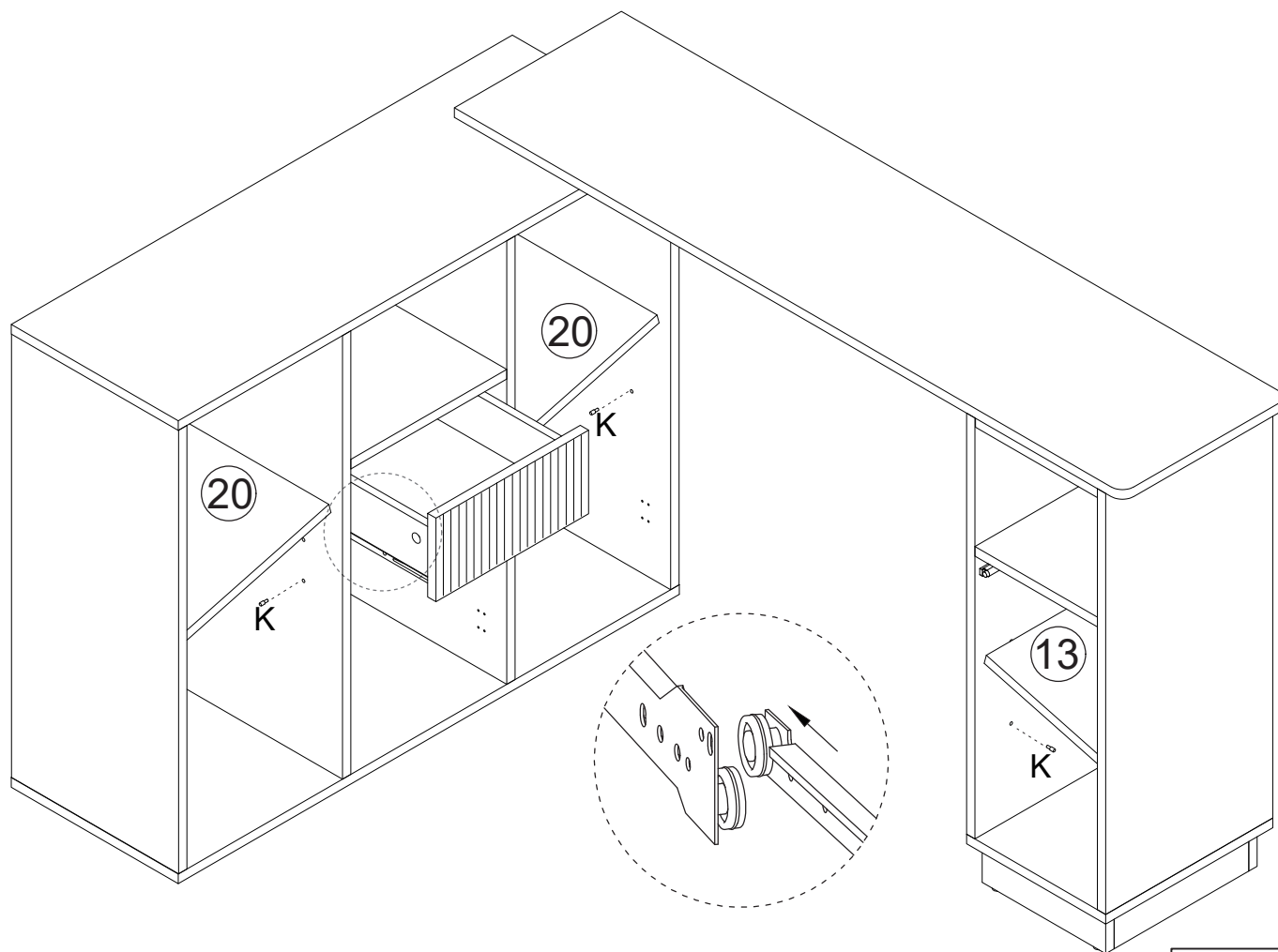

K x12pcs

STEP 22/SCHRITT 22/Étapes 22/Passo 22/Paso 22

X 2

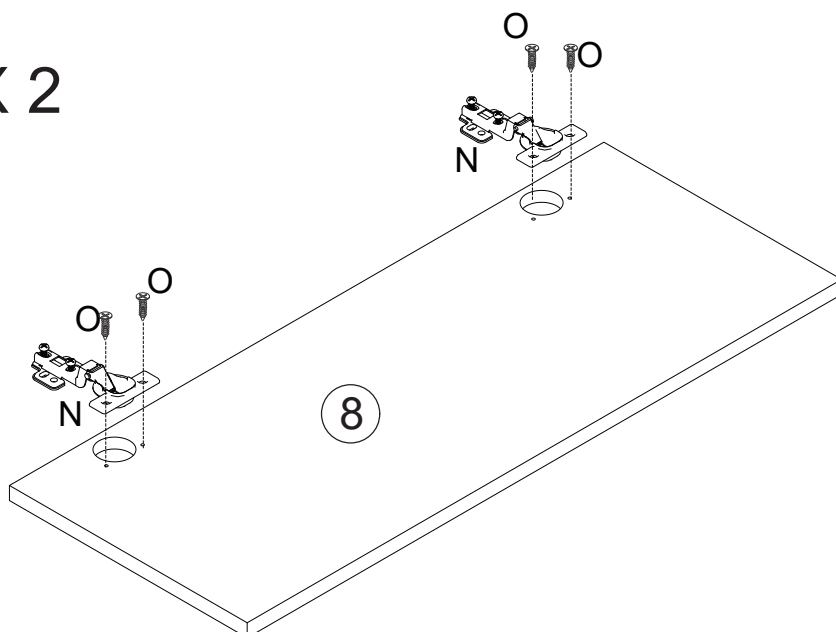

N x4pcs





O x8pcs

# Installationsanleitung/Installation Instruction/Instruction d'installation Istruzioni di installazione/Instrucciones de instalación

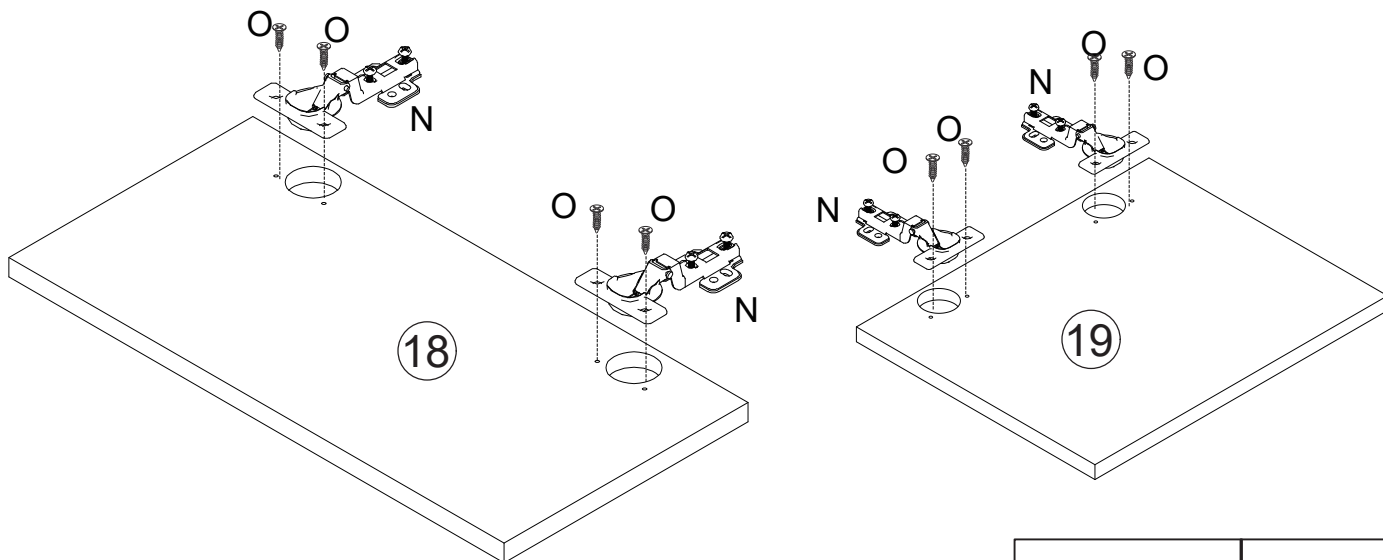
STEP 23/SCHRITT 23/Étapes 23/Passo 23/Paso 23

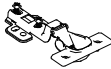

	
N x4pcs	O x8pcs

STEP 24/SCHRITT 24/Étapes 24/Passo 24/Paso 24

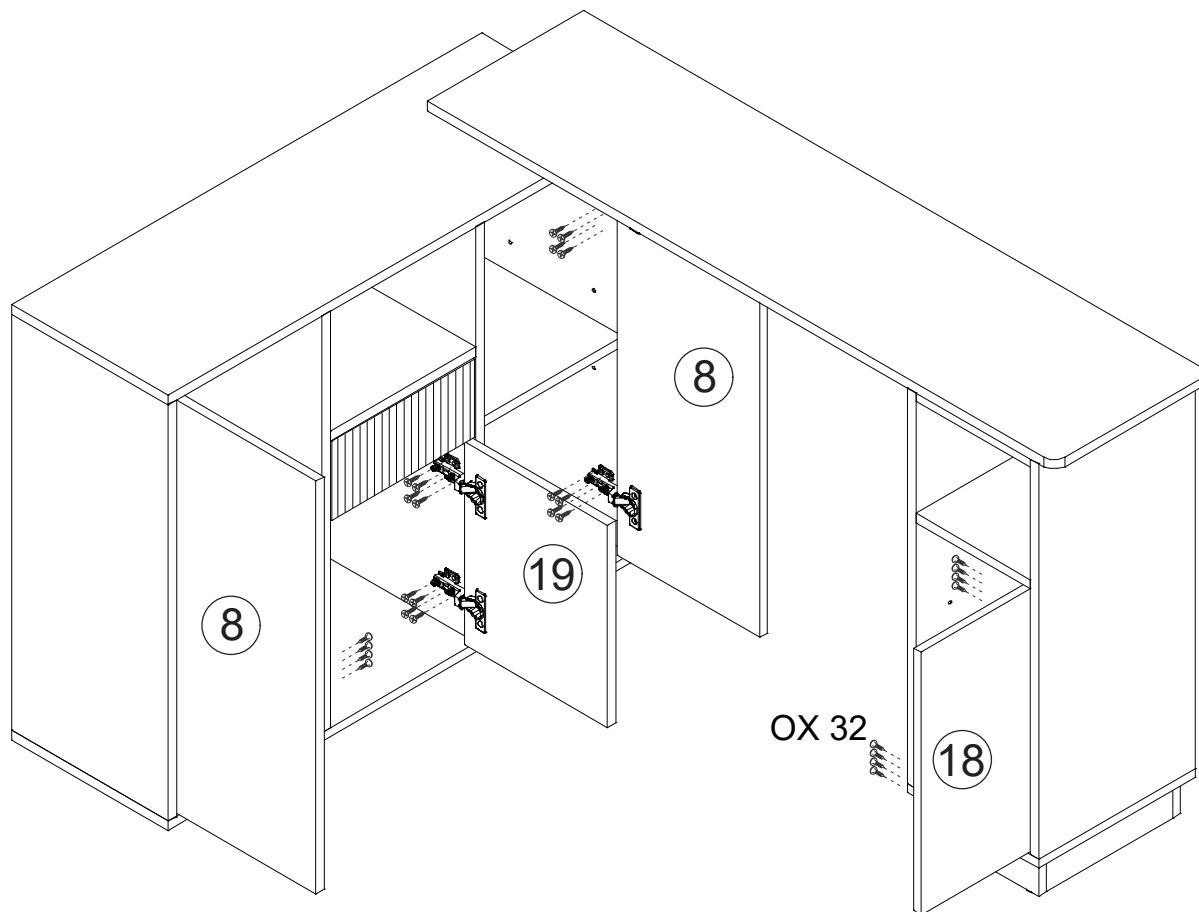

O x32pcs

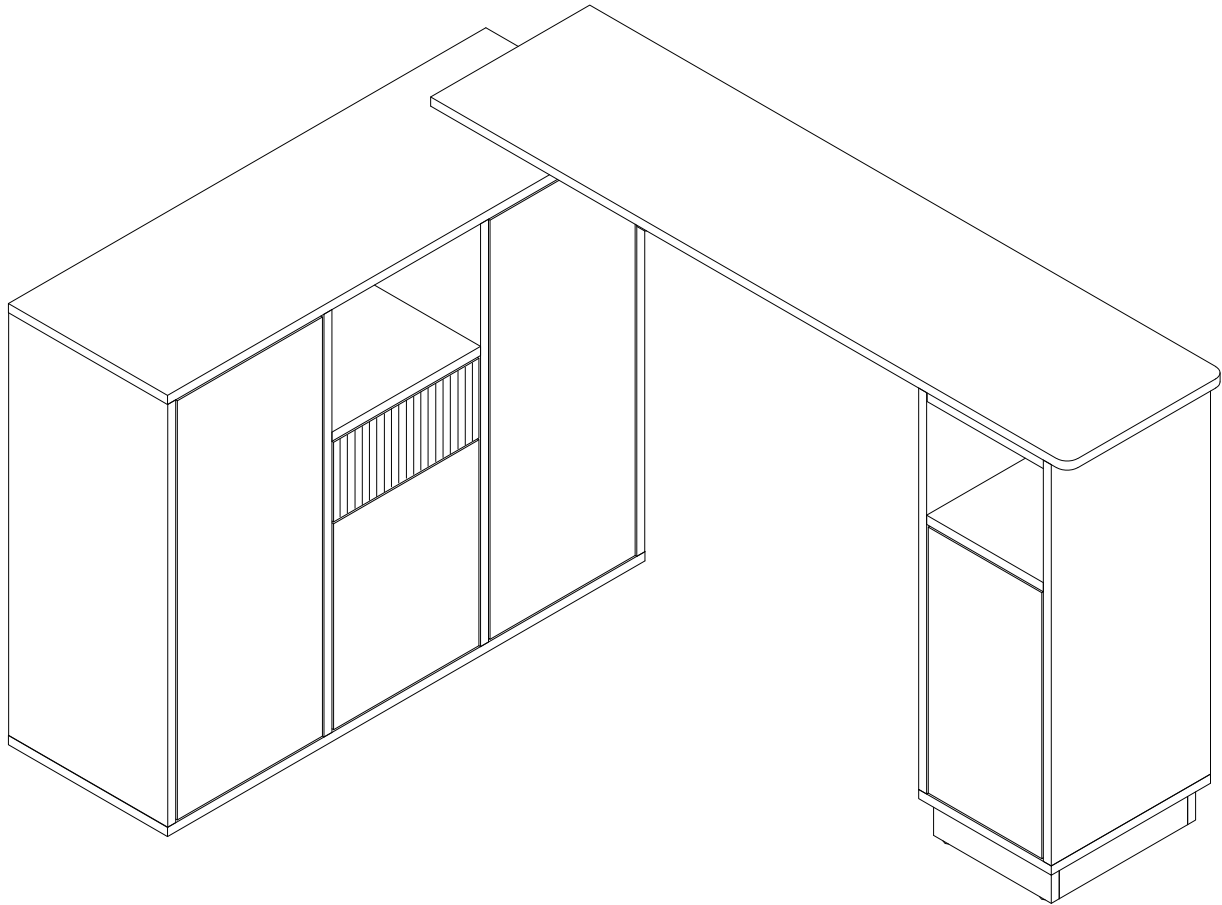

- When the hinges are installed, you can refer to the pictures to adjust crevice of the doors till it's perfect:
- Wenn die Scharniere installiert sind, können Sie sich die Bilder ansehen, um den Spalt der Türen anzupassen, bis es perfekt ist:
- Lorsque la charnière est installée, vous pouvez vous référer à l'image pour ajuster la fente de la porte jusqu'à ce qu'elle soit parfaite:

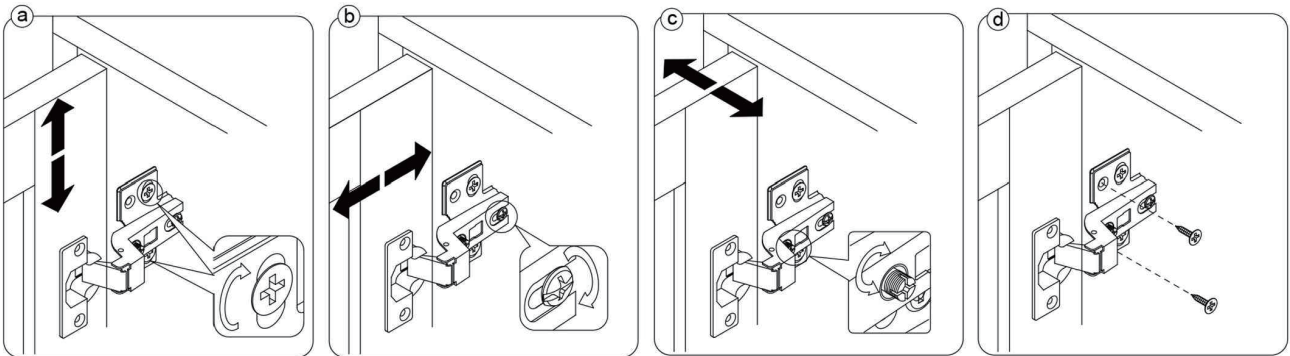

1. To adjust the doors up and down, please refer to step (a)
  2. To adjust the distance between the doors and side panels, please refer to step(b)
  3. To adjust the gap between two doors, please refer to step (c)
  4. After the adjustment finished, please tight the screws, refer to step(d)
1. Um die Türen nach oben und unten einzustellen, siehe Schritt (a)
  2. Um den Abstand zwischen den Türen und den Seitenwänden einzustellen, lesen Sie bitte Schritt(b)
  3. Um den Abstand zwischen zwei Türen einzustellen, siehe Schritt (c)
  4. Nachdem die Einstellung beendet ist, ziehen Sie bitte die Schrauben fest, siehe Schritt(d)
1. Pour régler les portes de haut en bas, reportez - vous à l'étape (A)
  2. Pour régler la distance entre la porte et le panneau latéral, reportez - vous à l'étape b)
  3. Pour régler l'écart entre les deux portes, reportez - vous à l'étape (c)
  4. Une fois le réglage terminé, serrez les vis, voir étape (d)

DE:Vor dem Einbau die Schrauben in die Löcher stecken und festziehen, aber nicht bis 100%, 70% bis 80% anziehen reicht aus. Schließlich, nachdem alle Schrauben installiert sind, ziehen Sie alle Schrauben auf 100%.

Wenn Sie auf diese Probleme stoßen, wie z. B. Fehlausrichtung der Löcher oder Unfähigkeit, bestimmte Teile zu installieren, überprüfen Sie bitte, ob die Schrauben korrekt verwendet werden und passen Sie die Dichtigkeit der Schrauben an.

UK:Before installation, insert the screws into the holes and tighten them, but do not tighten them to 100%, 70% to 80% is sufficient. Finally, after all screws are installed, tighten all screws to 100%.If you encounter these issues, such as if the holes cannot be aligned or some parts cannot be installed, please check if the screws are used correctly and adjust the tightness of the screws.

FR:Insérer la vis dans le trou avant la fin de l'assemblage, serrer la vis, mais ne pas serrer à 100%, 70% ~ 80% est correct. Enfin, une fois que toutes les vis sont bien serrées, toutes les vis sont serrées à 100%.

Si vous rencontrez ces problèmes, par exemple si les trous ne sont pas alignés ou si certaines pièces ne peuvent pas être montées, vérifiez que les vis sont utilisées correctement et Ajustez leur serrage.

IT: Prima dell'installazione, inserire le viti nei fori e stringerle, ma non al 100%, è sufficiente stringerle al 70% - 80%. Infine, dopo aver installato tutte le viti, stringere tutte le viti al 100%. Se riscontri problemi come disallineamenti dei fori o difficoltà nell'installare alcuni componenti, verifica che le viti siano utilizzate correttamente e regola la tensione delle viti.

ES: Antes de la instalación, coloque los tornillos en los agujeros y apriéte los, pero no al 100%; apretar al 70% - 80% es suficiente. Finalmente, después de haber instalado todos los tornillos, apriete todos los tornillos al 100%. Si se encuentra con problemas como desalineación de los agujeros o dificultad para instalar ciertas piezas, verifique que los tornillos se estén utilizando correcta