

Installationsanleitung Installation Instruction Instruction d'installation

Artikelnummer: **WF532102**

(Numéro d'article) **WF532103**

WF532104

UK:Our product will be delivered to you in 3 packages. The delivery times of these 3 packages may differ, please be patient and thank you for your understanding.

DE:Unser Produkt wird Ihnen in 3 Paketen geliefert. Die Lieferzeiten dieser 3 Pakete können abweichen, bitte haben Sie etwas Geduld und vielen Dank für Ihr Verständnis.

FR:Notre produit vous sera livré en 3 colis. Les délais de livraison de ces 3 colis peuvent différer, soyez patient et merci pour votre compréhension.

SINGLE BUNK BED FULL 200

140 x 200 CM

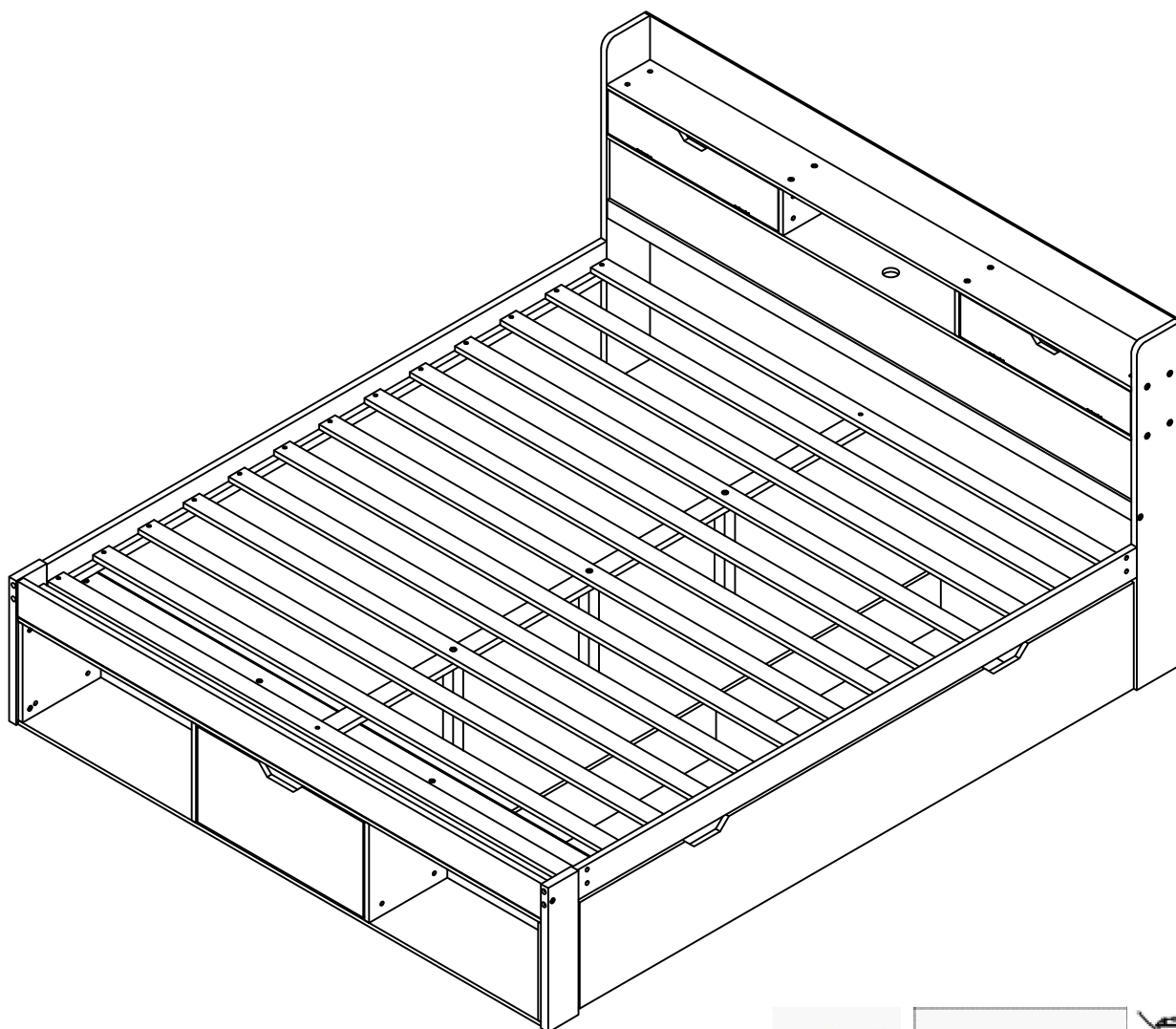

! SAFETY WARNINGS !

1. Please read the instructions fully before assembly. These instructions include important information which could ensure correct assembly. We have been working on providing high quality products for you. However, in the rare instance that your product is defective, missing parts or there are some issues, please don't hesitate to contact our customer service to submit parts requirements, assembly suggestion, or warranty claims, and we will give the best solution as soon as possible. If necessary, we need you to provide some more clear pictures of the issue.
2. Before installation, insert the screws into the holes and tighten them, but do not tighten them to 100%, 70% to 80% is sufficient. Finally, after all screws are installed, tighten all screws to 100%. If you encounter these issues, such as if the holes cannot be aligned or some parts cannot be installed, please check if the screws are used correctly and adjust the tightness of the screws.
3. 2 people are recommended to finish.

! SICHERHEITSWARNUNGEN !

1. Bitte lesen Sie die Anleitung vor der Montage vollständig durch. Diese Anleitung enthält wichtige Informationen, die eine korrekte Montage gewährleisten können. Wir haben daran gearbeitet, qualitativ hochwertige Produkte für Sie bereitzustellen. Sollte es jedoch in dem seltenen Fall vorkommen, dass Ihr Produkt defekt ist, Teile fehlen oder es Probleme gibt, zögern Sie bitte nicht, unseren Kundendienst zu kontaktieren, um Teileanforderungen, Montagevorschläge oder Garantieansprüche einzureichen. Wir werden Ihnen dann die beste Lösung anbieten schnellstmöglich. Bei Bedarf benötigen wir von Ihnen einige klarere Bilder des Problems.
2. Vor dem Einbau die Schrauben in die Löcher stecken und festziehen, aber nicht bis 100%, 70% bis 80% anziehen reicht aus. Schließlich, nachdem alle Schrauben installiert sind, ziehen Sie alle Schrauben auf 100%. Wenn Sie auf diese Probleme stoßen, wie z. B. Fehlausrichtung der Löcher oder Unfähigkeit, bestimmte Teile zu installieren, überprüfen Sie bitte, ob die Schrauben korrekt verwendet werden und passen Sie die Dichtigkeit der Schrauben an.
3. Für die Fertigstellung werden 2 Personen empfohlen

! AVERTISSEMENTS DE SÉCURITÉ !

1. Veuillez lire entièrement les instructions avant l'assemblage. Ces instructions contiennent des informations importantes qui pourraient garantir un assemblage correct. Nous avons travaillé pour vous fournir des produits de haute qualité. Cependant, dans les rares cas où votre produit est défectueux, qu'il manque des pièces ou qu'il y a des problèmes, n'hésitez pas à contacter notre service client pour soumettre des exigences en matière de pièces, des suggestions d'assemblage ou des réclamations au titre de la garantie, et nous vous proposerons la meilleure solution. dès que possible. Si nécessaire, nous avons besoin que vous fournissiez des images plus claires du problème.
2. Insérer la vis dans le trou avant la fin de l'assemblage, serrer la vis, mais ne pas serrer à 100%, 70% ~ 80% est correct. Enfin, une fois que toutes les vis sont bien serrées, toutes les vis sont serrées à 100%. Si vous rencontrez ces problèmes, par exemple si les trous ne sont pas alignés ou si certaines pièces ne peuvent pas être montées, vérifiez que les vis sont utilisées correctement et Ajustez leur serrage.
3. 2 personnes sont recommandées pour terminer

English **IMPORTANT ! KEEP FOR FUTURE REFERENCE : READ CAREFULLY**

- To be assembled by an adult. Assembly must be checked by an adult before use
- WARNING ! Keep all screws, small parts and plastic bags out of the reach of children
- Properly identify all parts before assembling
- Never use your item if any of its parts are broken or missing
- Should any problems arise, please contact our After Sales Service
- Manufacturer's instructions shall be followed at all times
- Care: Clean with a soft, dry cloth. In case of larger stains, carefully rub with a slightly damp, non-abrasive sponge
- Avoid the risk of fire by not placing furniture near sources of ignition or hot items
- Do not jump on the bed

Deutsch **WICHTIG ! ZUM SPÄTEREN NACHSCHLAGEN AUFBEWAHREN: SORGFÄLTIG LESEN**

- Muss von einem Erwachsenen zusammengebaut werden. Der Zusammenbau muss vor dem Gebrauch von einem Erwachsenen überprüft werden
- WARNUNG! Bewahren Sie alle Schrauben, Kleinteile und Plastikbeutel außerhalb der Reichweite von Kindern auf
- Kennzeichnen Sie vor dem Zusammenbau alle Teile richtig
- Benutzen Sie Ihren Artikel niemals, wenn Teile gebrochen sind oder fehlen
- Sollten Probleme auftreten, wenden Sie sich bitte an unseren Kundendienst
- Die Anweisungen des Herstellers sind stets zu befolgen
- Pflege: Mit einem weichen, trockenen Tuch reinigen. Bei größeren Flecken vorsichtig mit einem leicht feuchten, nicht scheuernden Schwamm abreiben. nicht scheuernden Schwamm
- Vermeiden Sie die Gefahr eines Brandes, indem Sie die Möbel nicht in der Nähe von Zündquellen oder heißen Gegenständen aufstellen
- Nicht auf das Bett springen

Français **IMPORTANT ! CONSERVER POUR RÉFÉRENCE ULTÉRIEURE : LIRE ATTENTIVEMENT**

- Le montage doit être effectué par un adulte. Le montage doit être vérifié par un adulte avant Utilisation
- ATTENTION ! Tenir les vis, les petites pièces et les sachets en plastique hors de portée des enfants
- Identifiez correctement toutes les pièces avant de les assembler
- N'utilisez jamais votre article si l'une de ses pièces est cassée ou manquante
- En cas de problème, veuillez contacter notre service après-vente
- Les instructions du fabricant doivent être respectées à tout moment
- Entretien : nettoyer avec un chiffon doux et sec. En cas de taches plus importantes, frotter soigneusement avec une éponge non abrasive légèrement humide. légèrement humide et non Abrasive
- Évitez les risques d'incendie en ne plaçant pas les meubles à proximité de sources d'inflammation ou d'objets chauds
- Ne pas sauter sur le lit

Italiano | **IMPORTANTE! CONSERVARE PER RIFERIMENTO FUTURO: LEGGERE ATTENTAMENTE**

- Deve essere assemblato da un adulto. L'assemblaggio deve essere controllato da un adulto prima dell'uso
- **ATTENZIONE!** Tenere tutte le viti, le piccole parti e i sacchetti di plastica fuori dalla portata dei bambini
- Identificare correttamente tutte le parti prima dell'assemblaggio
- Non utilizzare mai l'articolo se alcune parti sono rotte o mancanti
- In caso di problemi, si prega di contattare il nostro Servizio Post Vendita
- Le istruzioni del produttore devono essere sempre seguite
- Cura: Pulire con un panno morbido e asciutto. In caso di macchie più estese, strofinare accuratamente con una spugna leggermente umida e nonspugna leggermente umida e non abrasiva
- Evitare il rischio di incendio, non collocando i mobili vicino a fonti di accensione o a oggetti caldi
- Non saltare sul letto

Español | **¡IMPORTANTE ! CONSÉRVELO PARA FUTURAS CONSULTAS: LEA ATENTAMENTE**

- Debe ser montado por un adulto. El montaje debe ser comprobado por un adulto antes del uso
- **ADVERTENCIA** Mantenga todos los tornillos, piezas pequeñas y bolsas de plástico fuera del alcance de los niños.
- Identifique correctamente todas las piezas antes de montarlas
- Nunca utilice su artículo si alguna de sus piezas está rota o falta
- Si surge algún problema, póngase en contacto con nuestro Servicio Postventa
- Las instrucciones del fabricante deben seguirse en todo momento
- Cuidado: Limpiar con un paño suave y seco. En caso de manchas más grandes, frote cuidadosamente con una esponja no abrasiva ligeramente humedecida.
- Evite el riesgo de incendio no colocando los muebles cerca de fuentes de ignición u objetos calientes.
- No saltar sobre la cama.

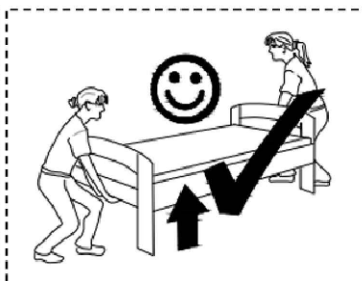
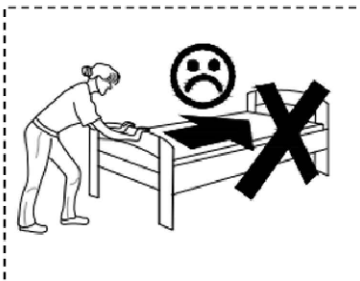



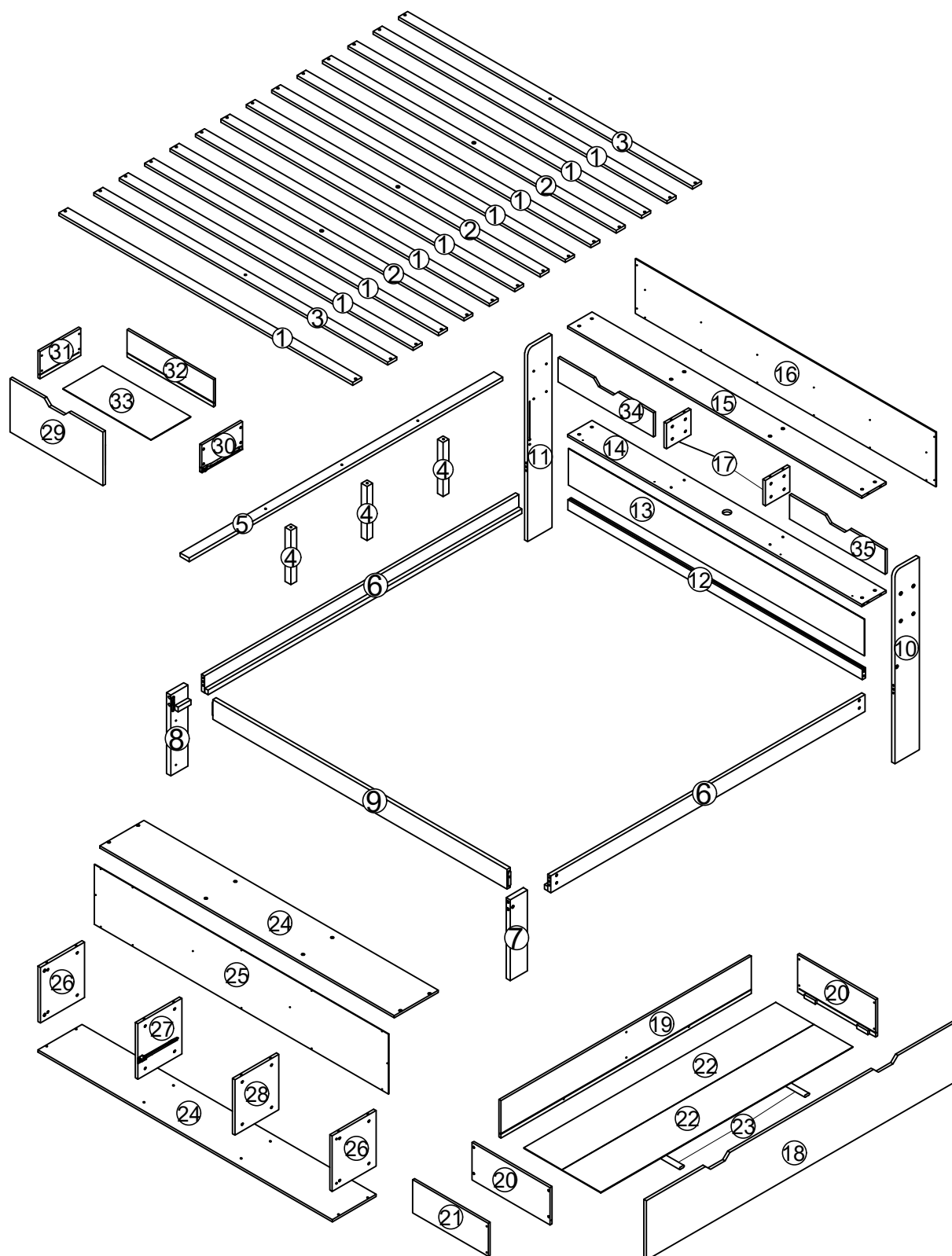

Stückliste /Liste bloquée



WF532102

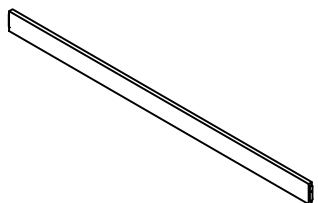

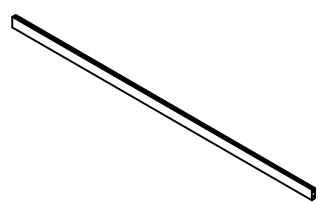
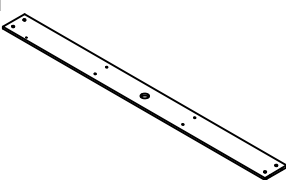
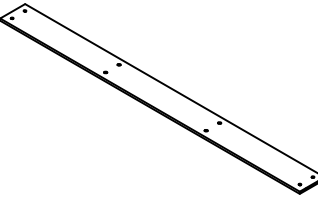
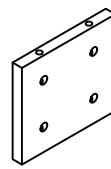
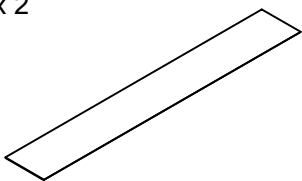
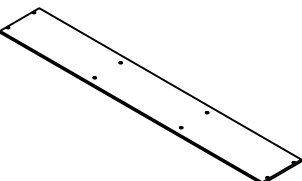
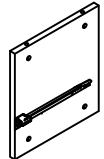
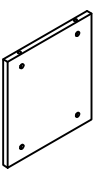
**(Stückliste Und Hardware-Liste/
Liste du matériel)**

<p>⑦ x 1</p> 	<p>⑧ x 1</p> 	<p>⑨ x 1</p> 
<p>⑩ x 1</p> 	<p>⑪ x 1</p> 	<p>⑫ x 1</p> 
<p>⑭ x 1</p> 	<p>⑮ x 1</p> 	<p>⑰ x 2</p> 
<p>⑳ x 2</p> 	<p>㉔ x 2</p> 	<p>㉗ x 1</p> 
<p>㉘ x 1</p> 		

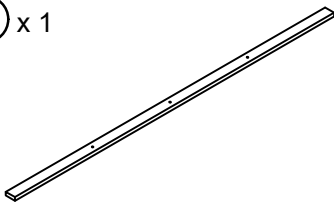
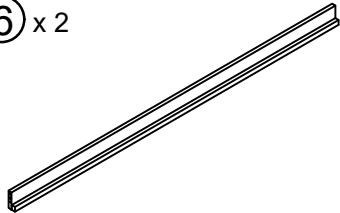
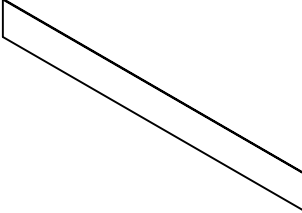
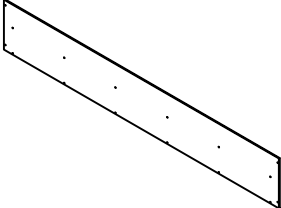
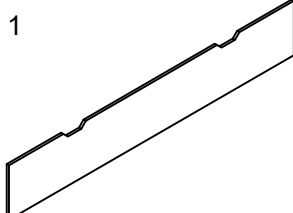
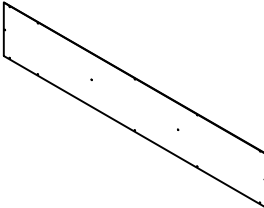
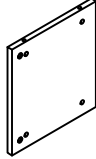
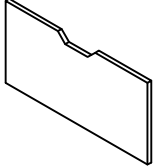
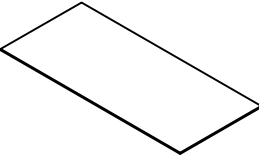
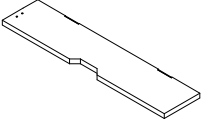
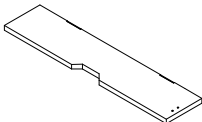
WF532103

⑤ x 1 	⑥ x 2 	⑬ x 1 
⑯ x 1 	⑱ x 1 	⑳ x 1 
㉔ x 2 	㉗ x 1 	㉙ x 1 
㉛ x 1 	㉝ x 1 	

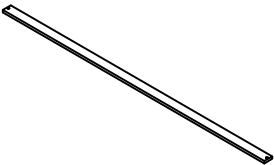
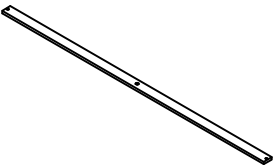
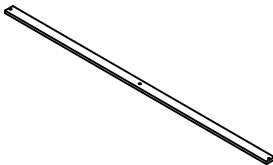
WF532104

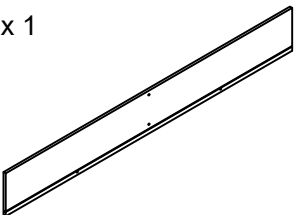
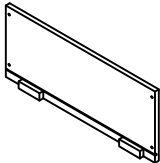
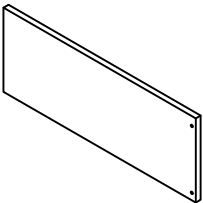
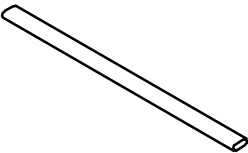
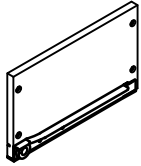
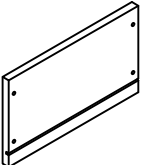
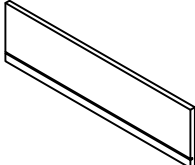

<p>① x 9</p> 	<p>② x 3</p> 	<p>③ x 2</p> 
<p>④ x 3</p> 	<p>⑱ x 1</p> 	<p>⑳ x 2</p> 
<p>㉑ x 1</p> 	<p>㉓ x 2</p> 	<p>㉓ x 1</p> 
<p>㉔ x 1</p> 	<p>㉕ x 1</p> 	

WF532102

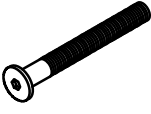
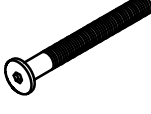
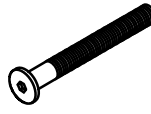

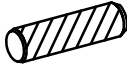

(Stückliste Und Hardware-Liste/ Liste du matériel)

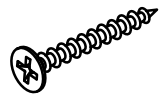
<p>(A)</p>  <p>M6 x 120mm = 8 PCS</p>	<p>(B)</p>  <p>M6 x 60mm = 36 PCS</p>	<p>(C)</p>  <p>M6 x 50mm = 3 PCS</p>
--	--	---

DK: Bitte beachten Sie, dass die Formen der Schrauben (A) und (B) und (C) ähnlich sind. Bitte installieren Sie entsprechend der Anleitung und unterscheiden Sie sie!
UK: Please no trhat the shapes of screw (A) and (B) and (C) are similar. Please are install arccoding to the instructions and distinguish them!
FK: Notez que les vis (A) und (B) und (C) ont des formens similaires. Veuillez installer en suivant les instructions pour les se'parer!

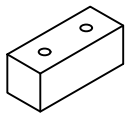
<p>(D)</p>  <p>M6 x 13 mm = 44 PCS</p>	<p>(E)</p>  <p>Ø10 x 40 mm = 6 PCS</p>	
<p>(F)</p>  <p>M4 x 15 mm = 32 PCS</p>	<p>(G)</p>  <p>M3 x 10 mm = 20 PCS</p>	<p>(H)</p>  <p>M4 x 30 mm = 56 PCS</p>

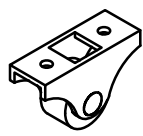
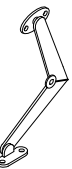
DK: Bitte beachten Sie, dass die Formen der Schrauben (F) und (G) und (H) ähnlich sind. Bitte installieren Sie entsprechend der Anleitung und unterscheiden Sie sie!
UK: Please no trhat the shapes of screw (F) and (G) and (H) are similar. Please are install arccoding to the instructions and distinguish them!
FK: Notez que les vis (F) und (G) und (H) ont des formens similaires. Veuillez installer en suivant les instructions pour les se'parer!

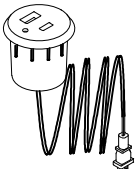
<p>(I)</p>  <p>50x20x20 mm = 2 PCS</p>	<p>(J)</p>  <p>Ø6x30mm = 4 PCS</p>	<p>(K)</p>  <p>(H=28mm) = 4 PCS</p>
<p>(L)</p>  <p>132 mm = 1 PC (left)</p>	<p>(M)</p>  <p>132 mm = 1 PC (right)</p>	<p>(N)</p>  <p>Usb Power = 1 PC</p>

<p>(O)</p>  <p>1 PC</p>
--

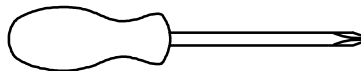

Assembly Tools Required (Not Included)

Wichtiger Hinweis:

Bestatigen Sie bitte alle Komponenten und Schrauben vor der Montage. Bitte wenden Sie sich an uns, falls einige Teile oder Schrauben im Paket fehlt sind.

Outils d'assemblage requis (non inclus)

Signification du Wichtiger :

Bestatigen Sie bitte alle Komponenten and Schrauben vor der Montage. Bitte wenden Sie sich an us, Falls einige Teile ou Schrauben im paket fehlt sind.

Schritt 1:
Step 1:

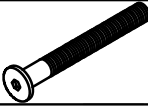
B		M6x 60	8 pcs
D		M6x13	8 pcs

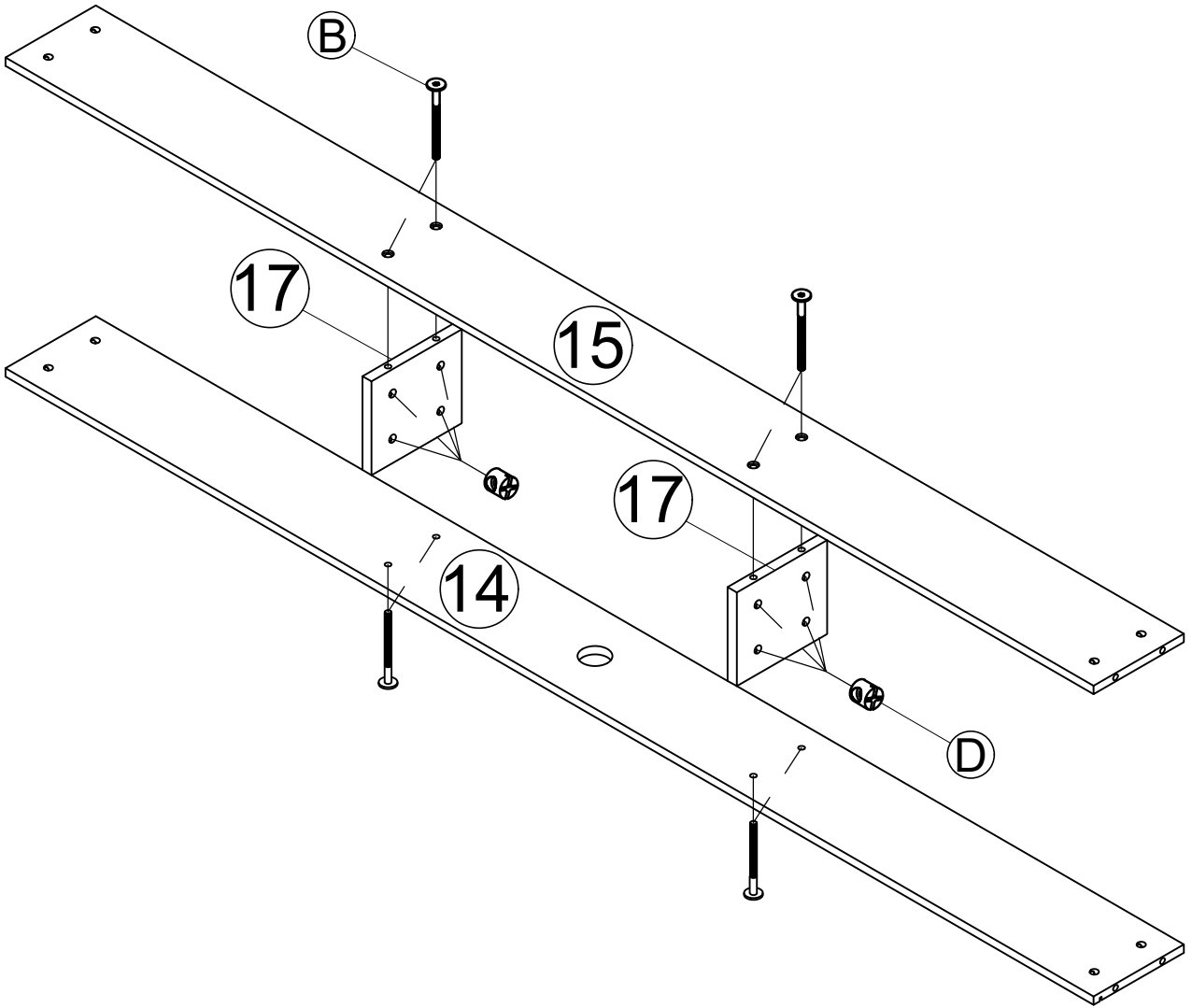

Schritt 2:

Step 2:

B		M6x 60	10 pcs
D		M6x13	10 pcs
E		Ø10 x 40	2 pcs

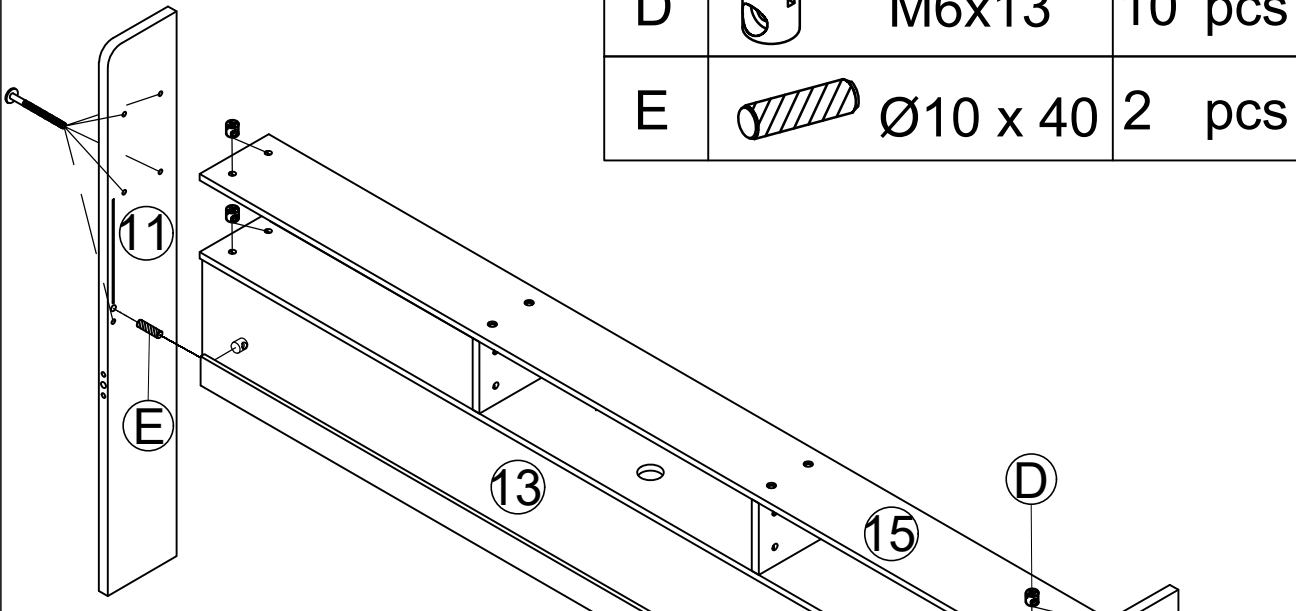

Schritt 3:

Step 3:

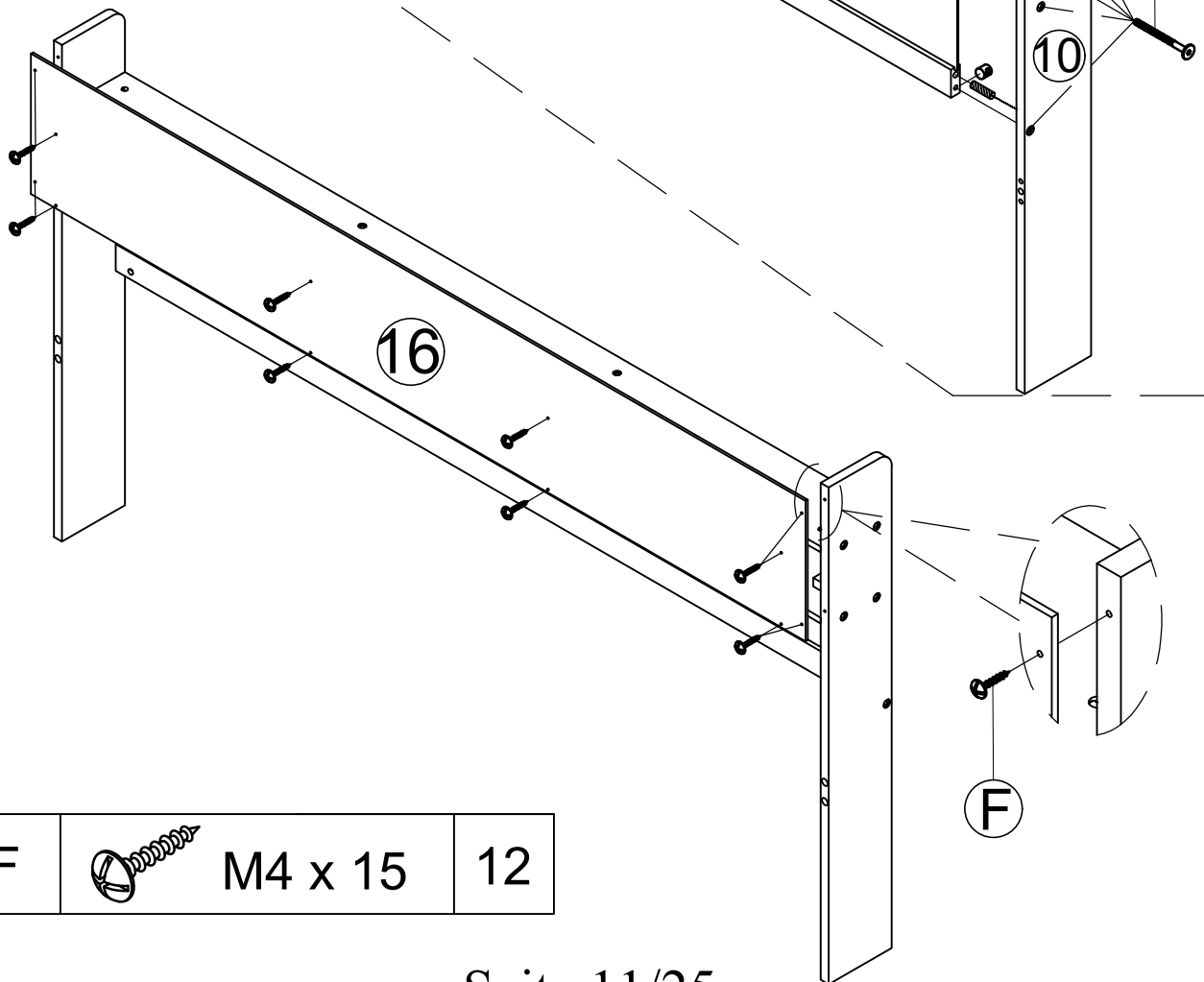

F

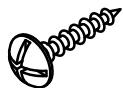





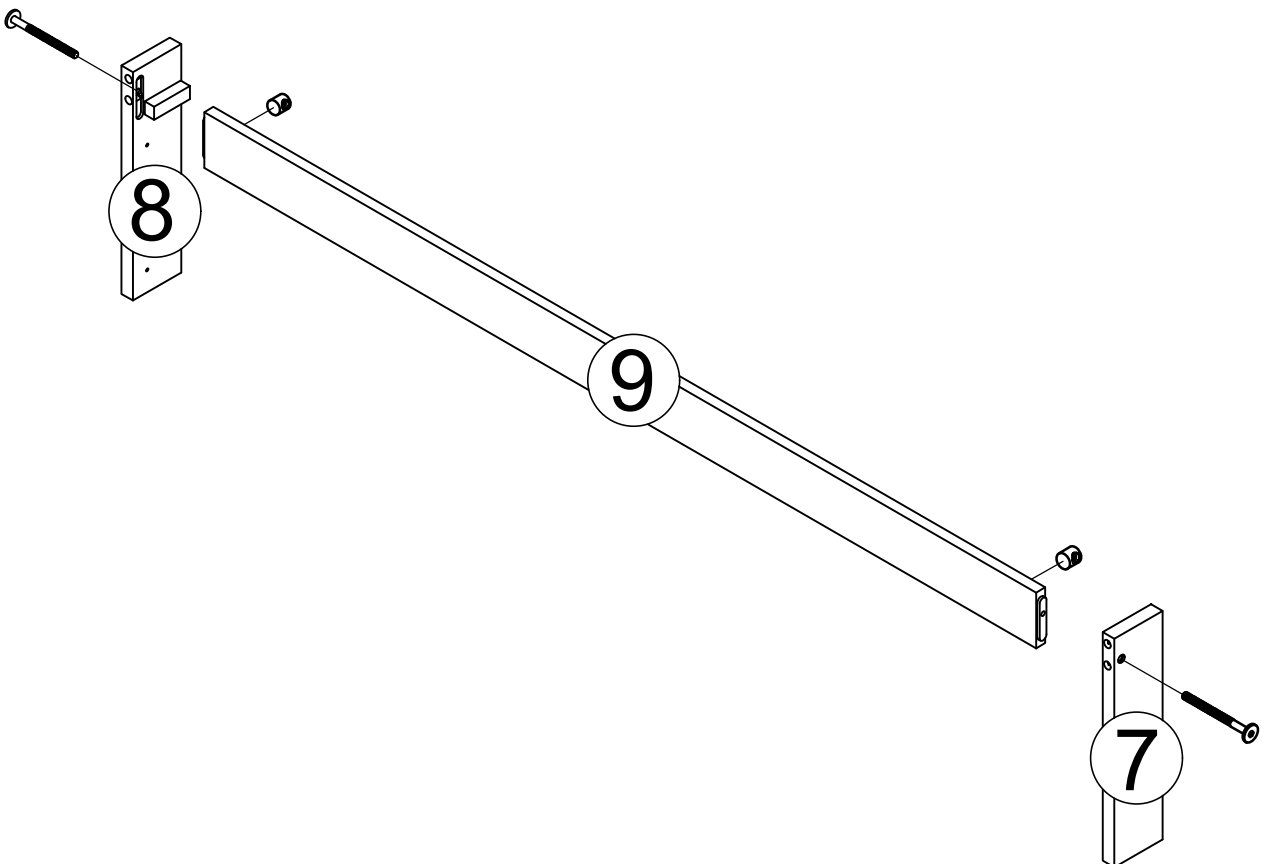
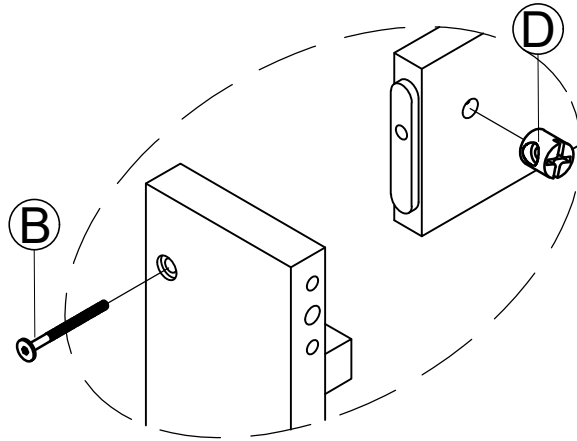

M4 x 15

12

Schritt 4:
Step 4:

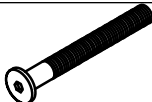
B		M6x 60	2 pcs
D		M6x13	2 pcs





H	 M4 x 30	4 pcs	A	 M6x120	8 pcs
I	 50x20x20	2 pcs	D	 M6x 13	8 pcs
			E	 Ø10 x 40	4 pcs

Schritt 5:

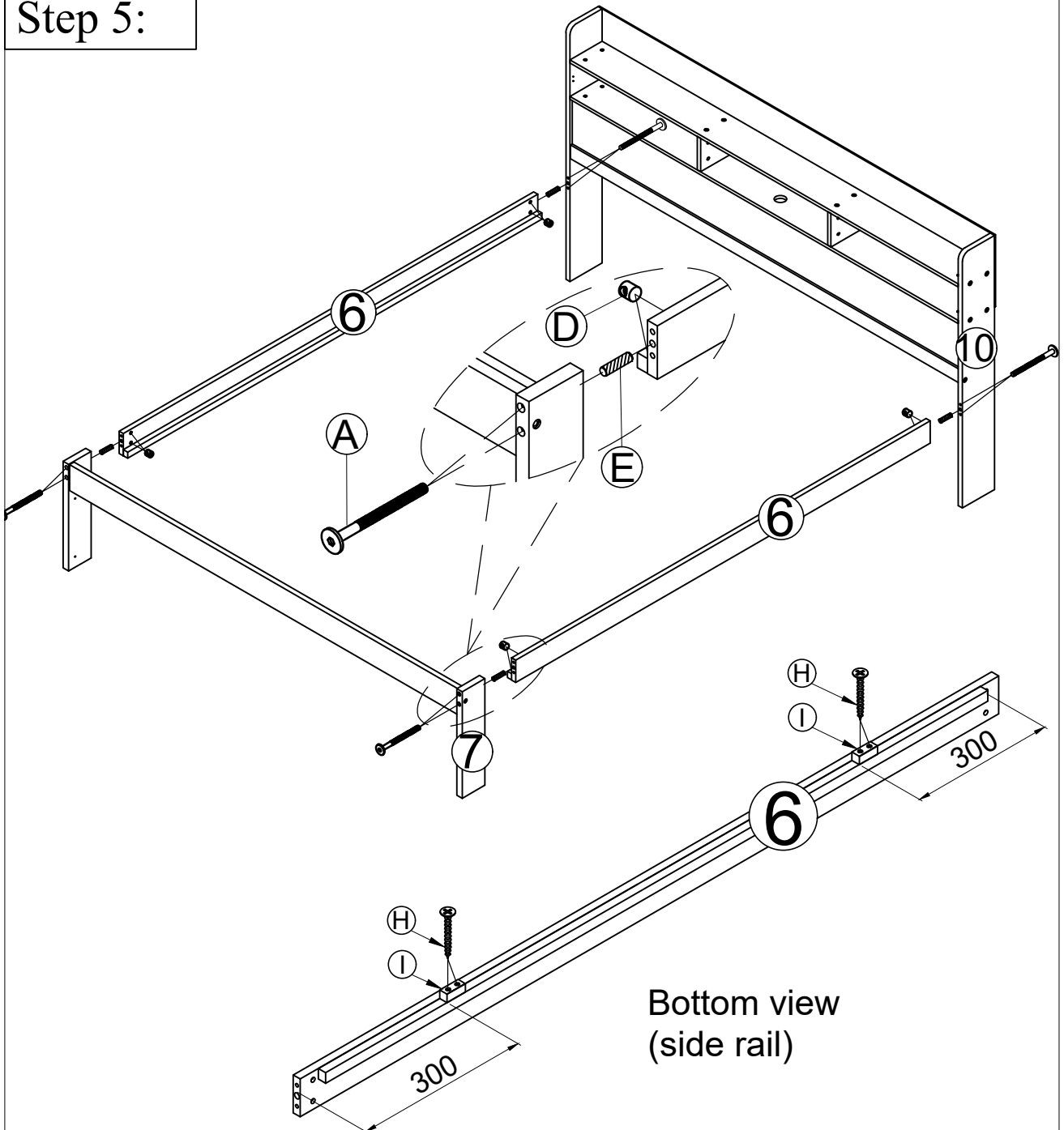
Step 5:

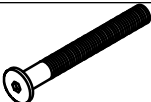

Schritt 6:
Step 6:

B		M6x 60	16 pcs
D		M6x13	16 pcs

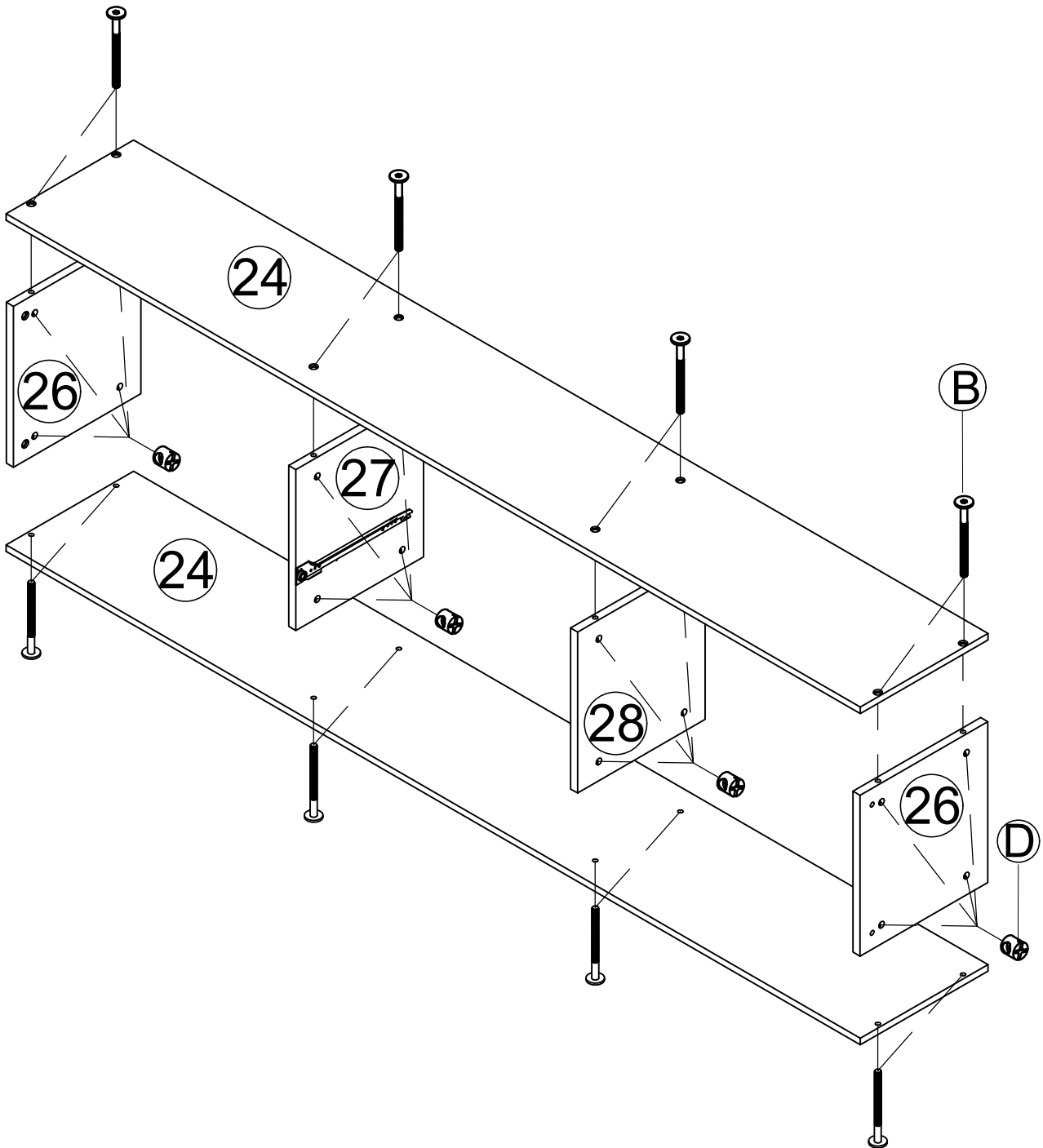

Schritt 7:

Step 7:

F



M4 x 15

12 pcs

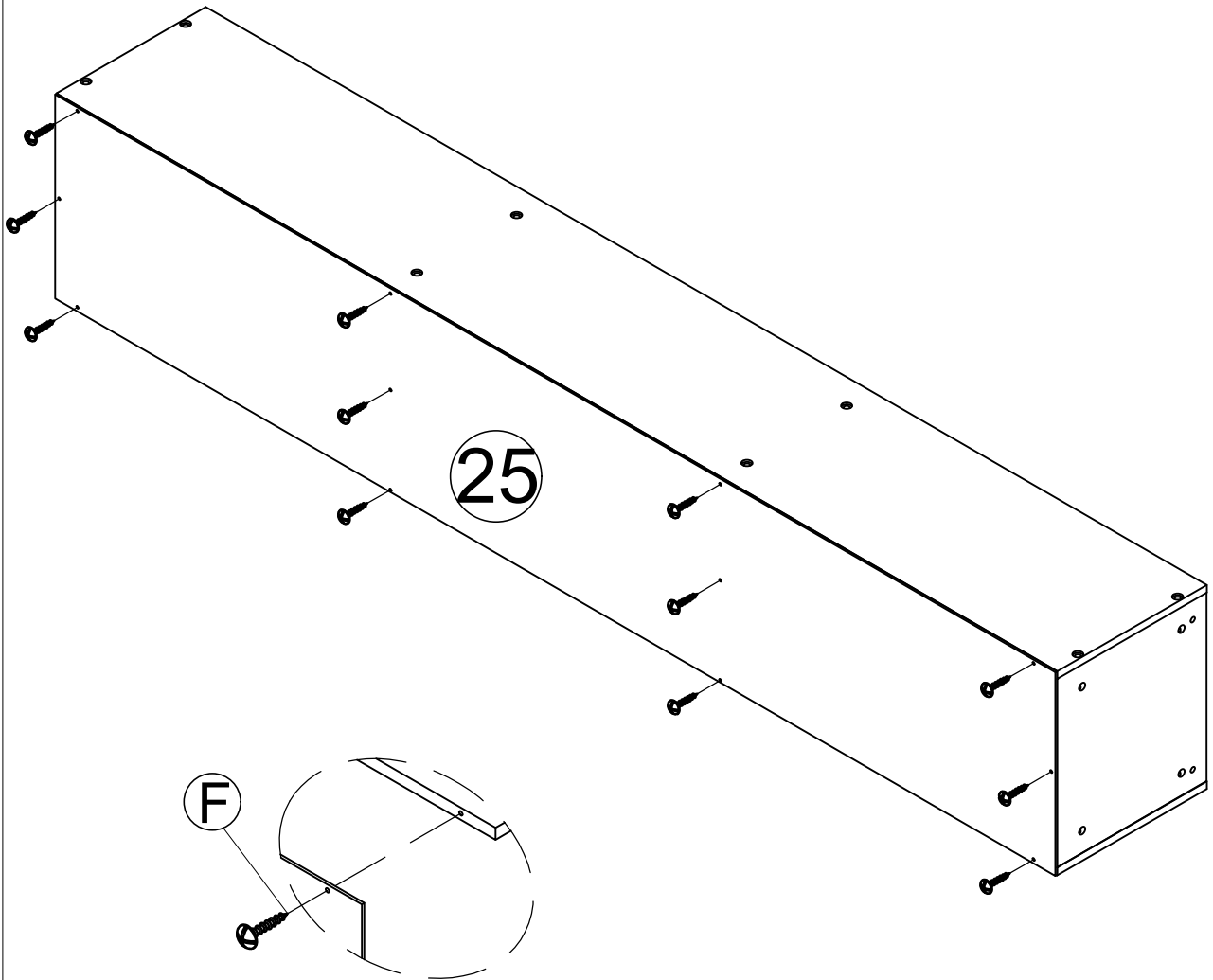

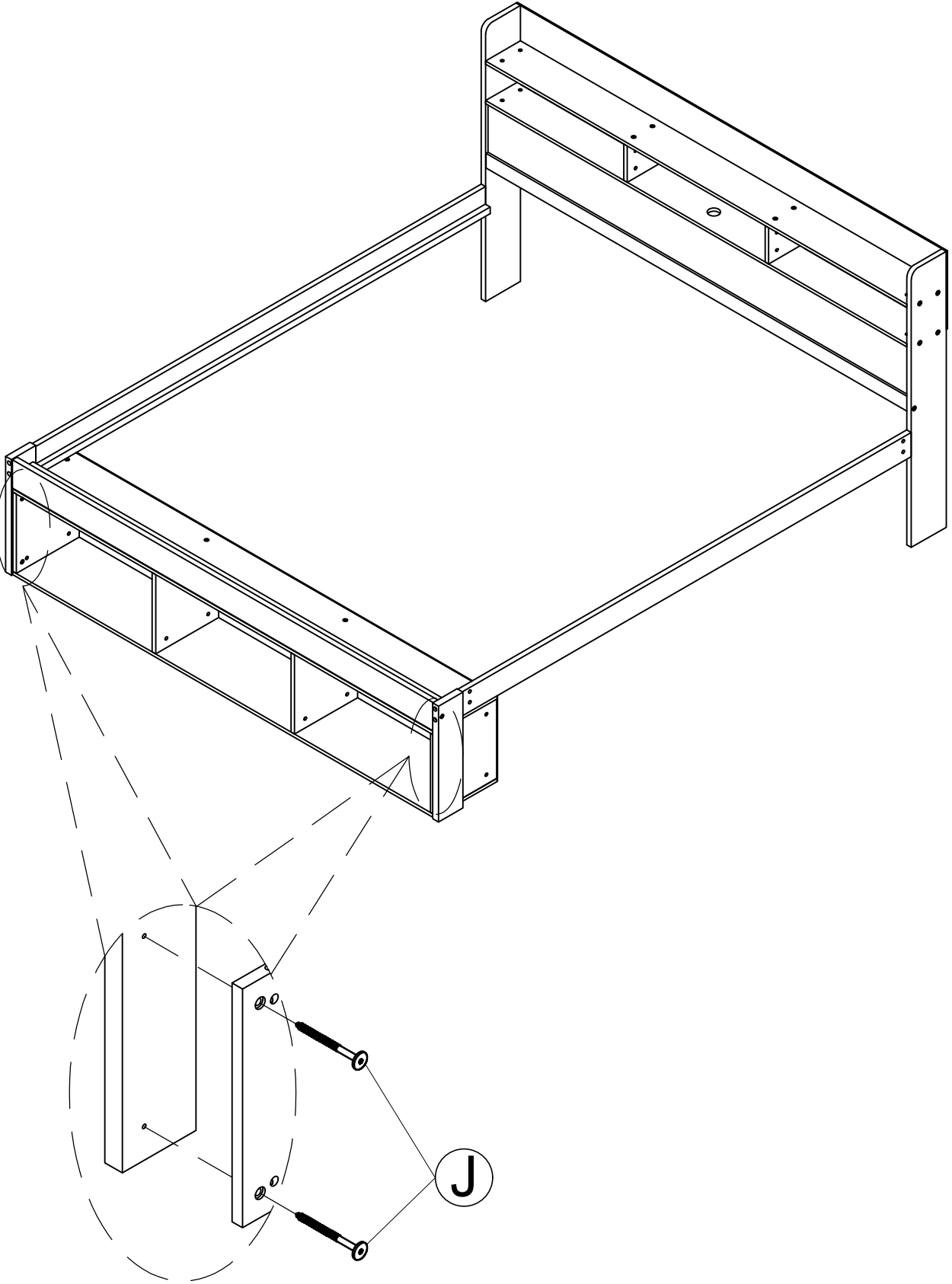

Schritt 8:
Step 8:

J		Ø6x30	4 pcs
---	---	-------	-------



Schritt 9:
Step 9:

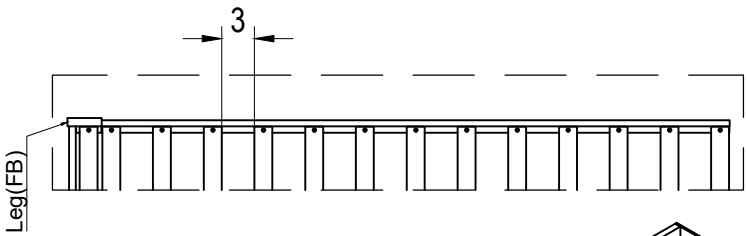
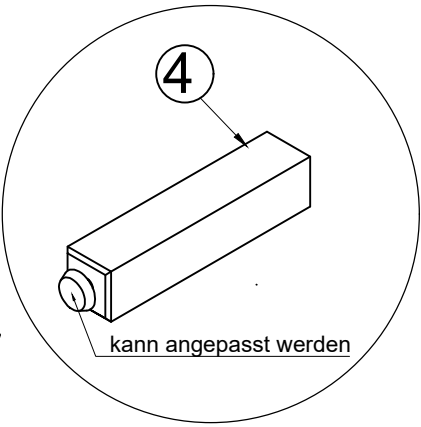
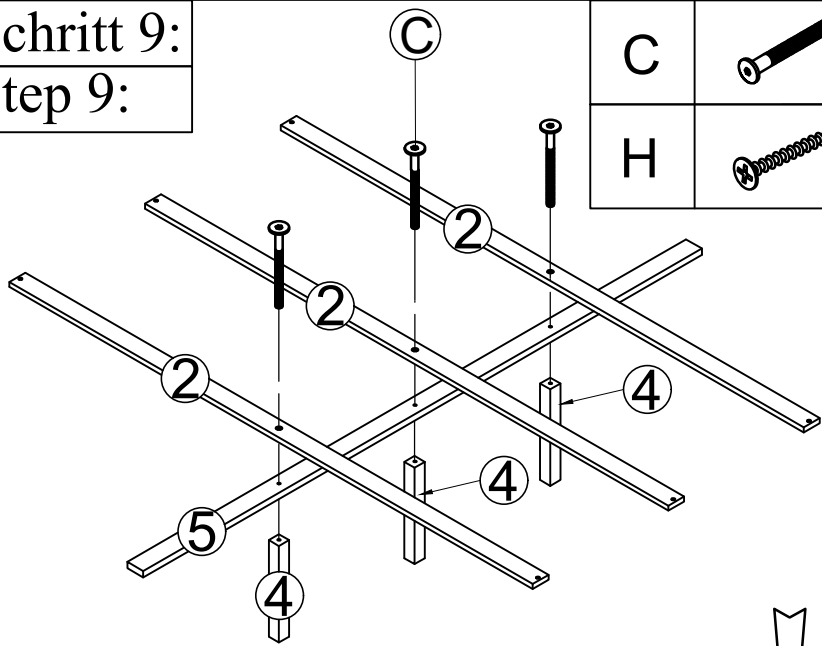

C		M6x50	3 pcs
H		M4x30	30 pcs

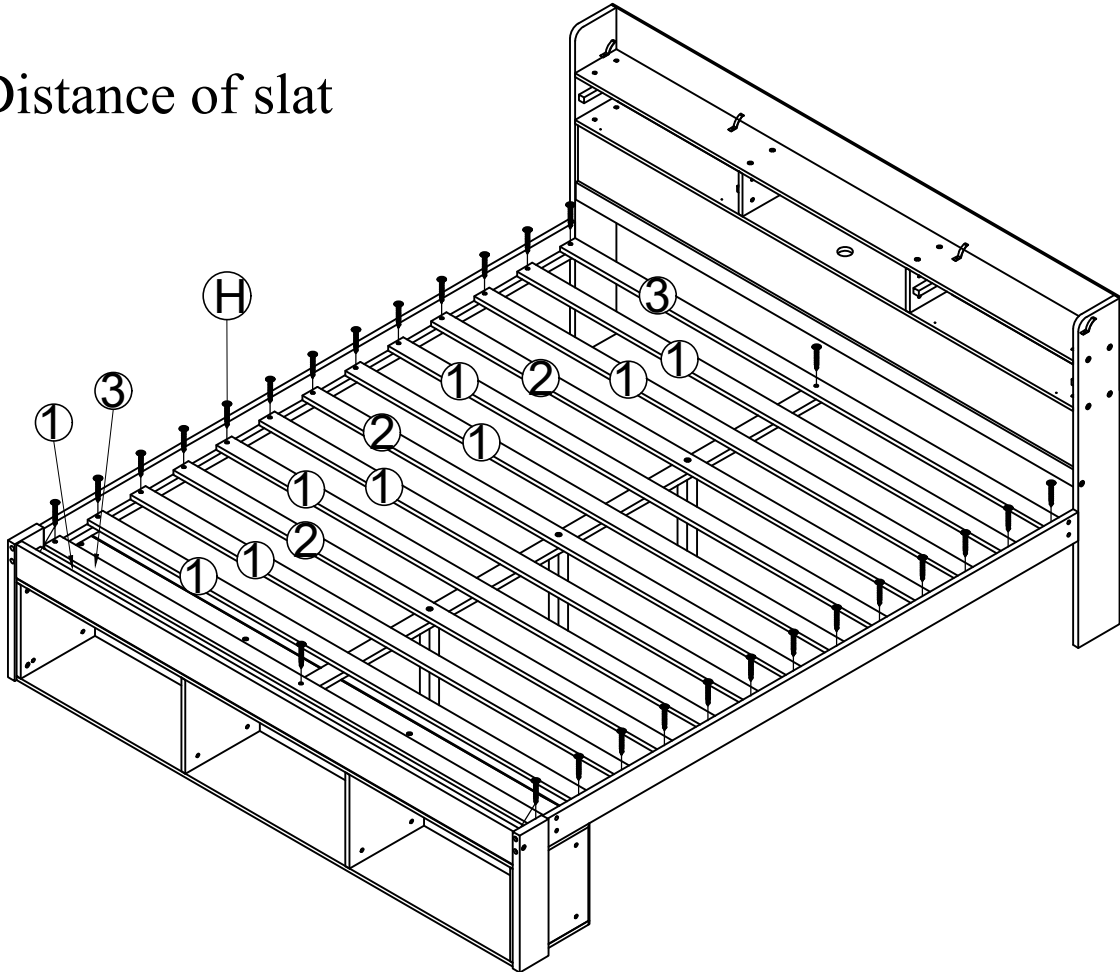

Distance of slat



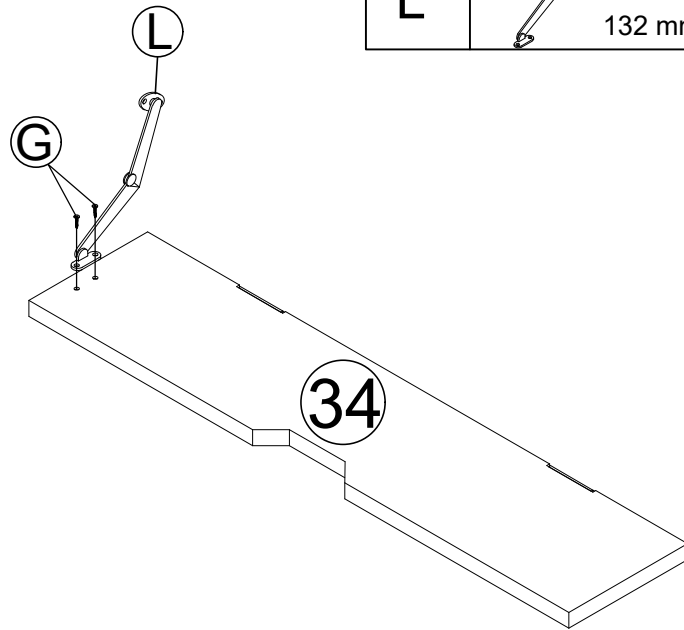

Schritt 10-1:
Step 10-1:

G	 M3 x 10	2 pcs
L	 132 mm(left)	1 pc



Schritt 10-2:
Step 10-2:

G	 M3 x 10	2 pcs
M	 132 mm(right)	1 pc

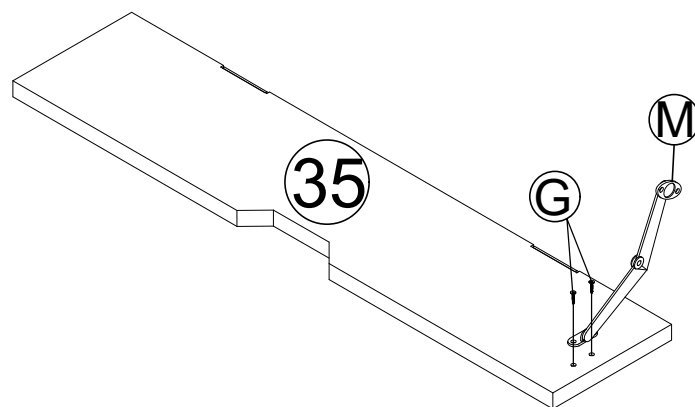

Schritt 11:
Step 11:

G  M3 x 10 12 pcs

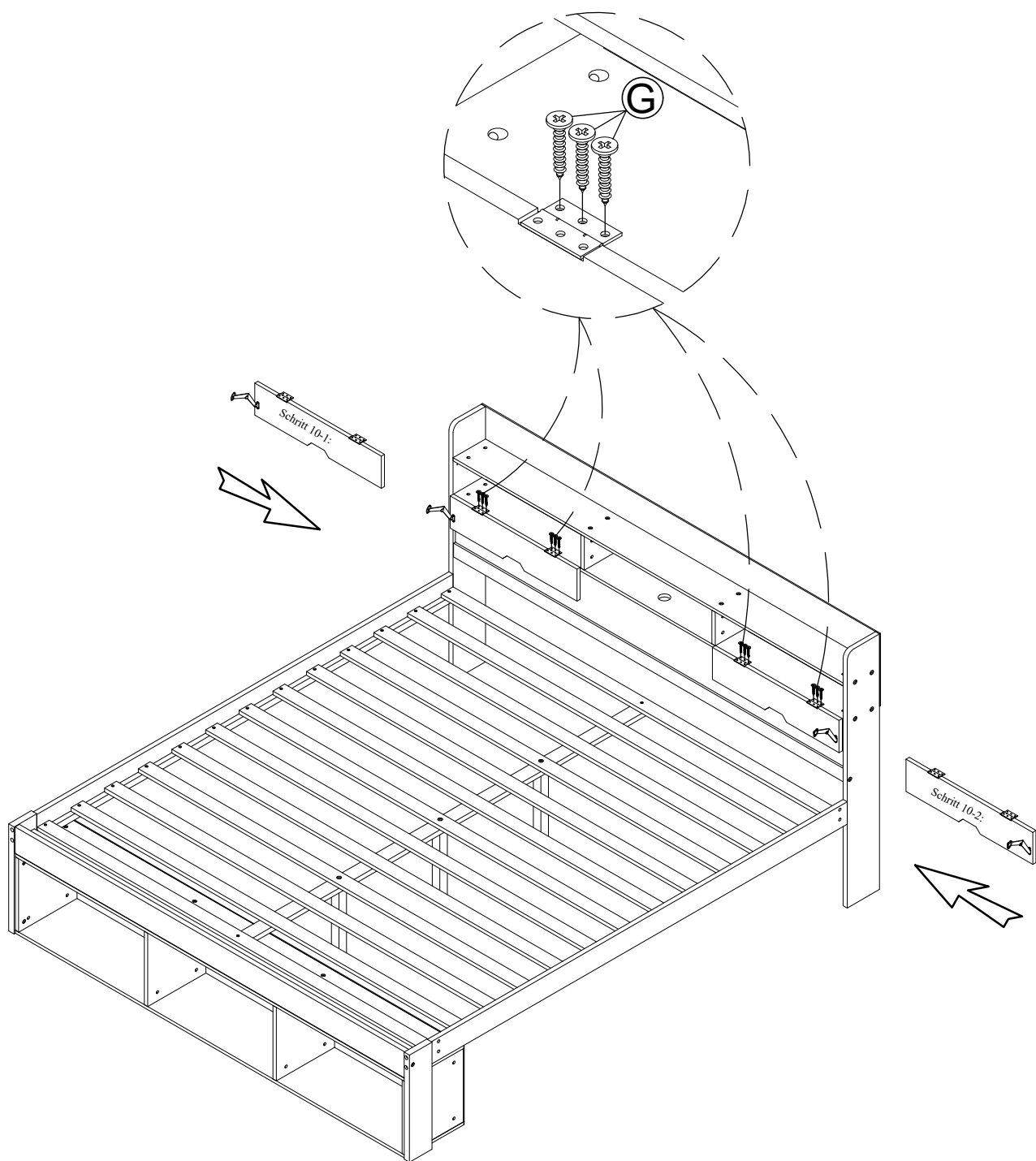

Schritt 12:

Step 12:

G



M3 x 10

4

pcs

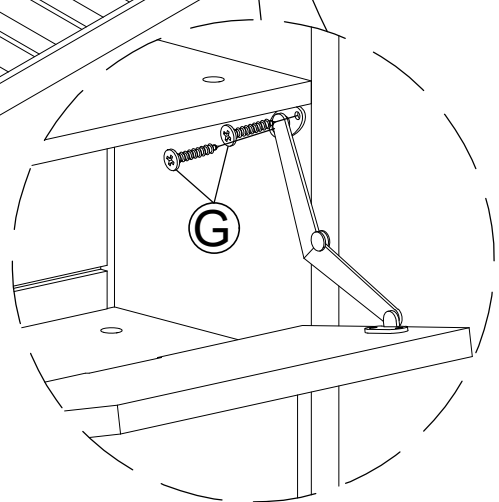
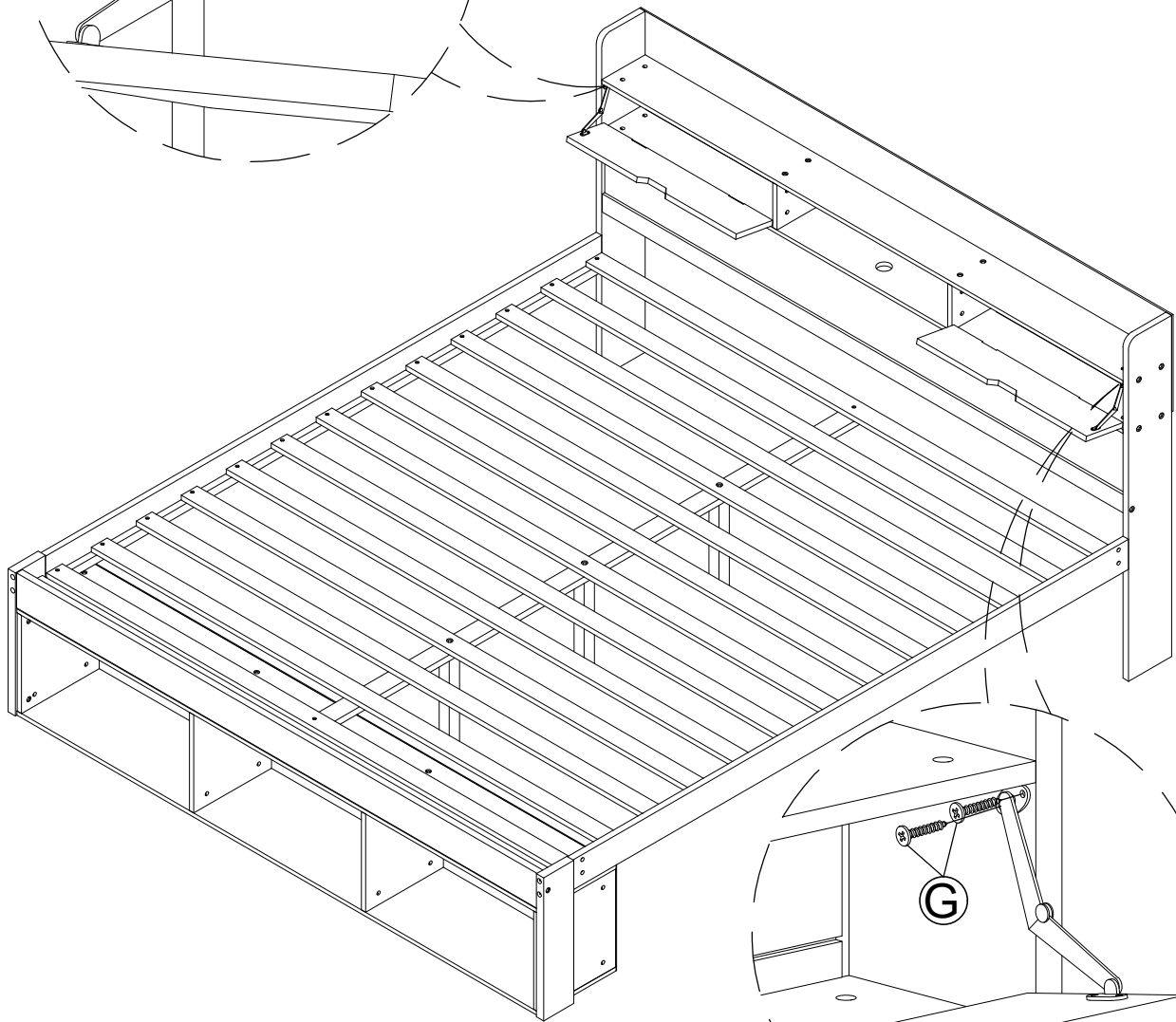
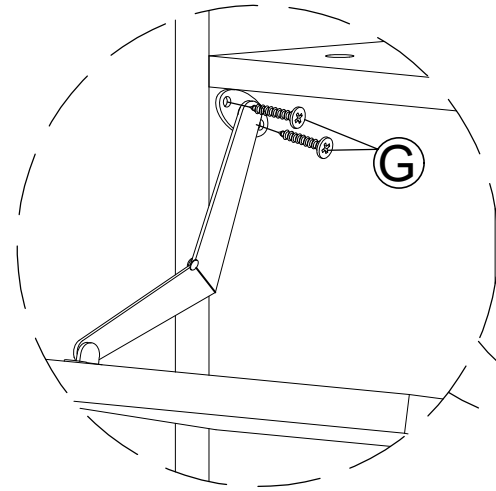

Schritt 13-1:
Step 13-1:

H		M4 x 30	4	pcs
---	--	---------	---	-----

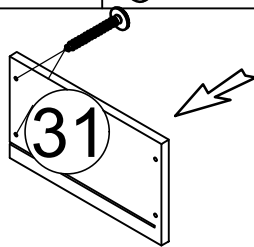
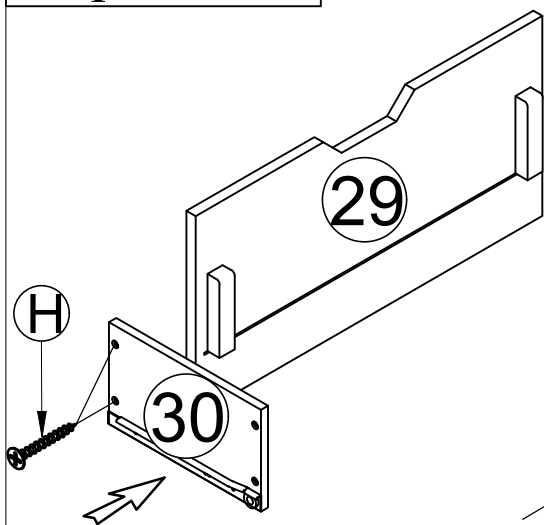

Schritt 13-2:
Step 13-2:

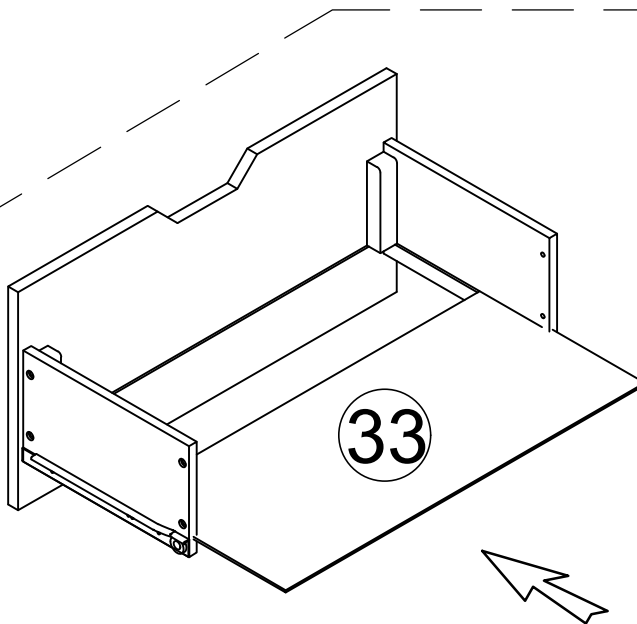

Schritt 13-3:
Step 13-3:

H		M4 x 30	4
---	--	---------	---

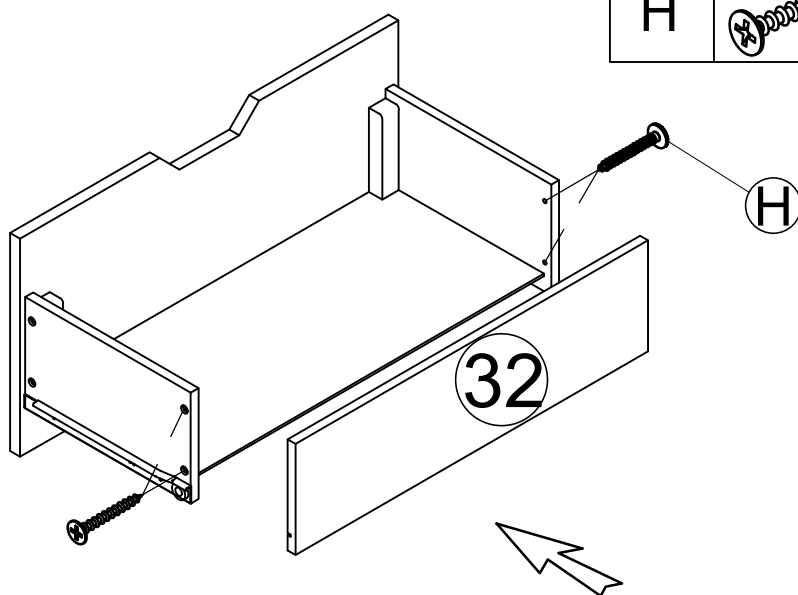

Schritt 14-1:

Step 14-1:

H



M4 x 30

4 pcs

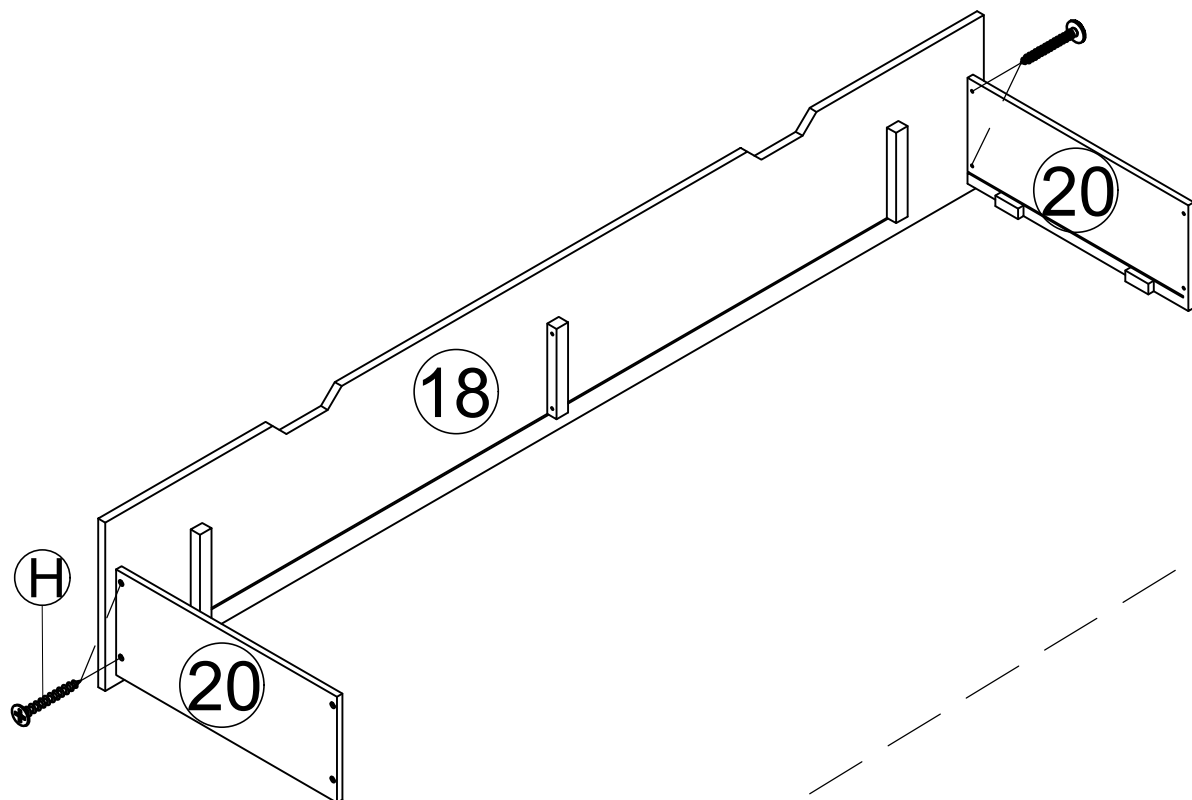

Schritt 14-2:

Step 14-2:

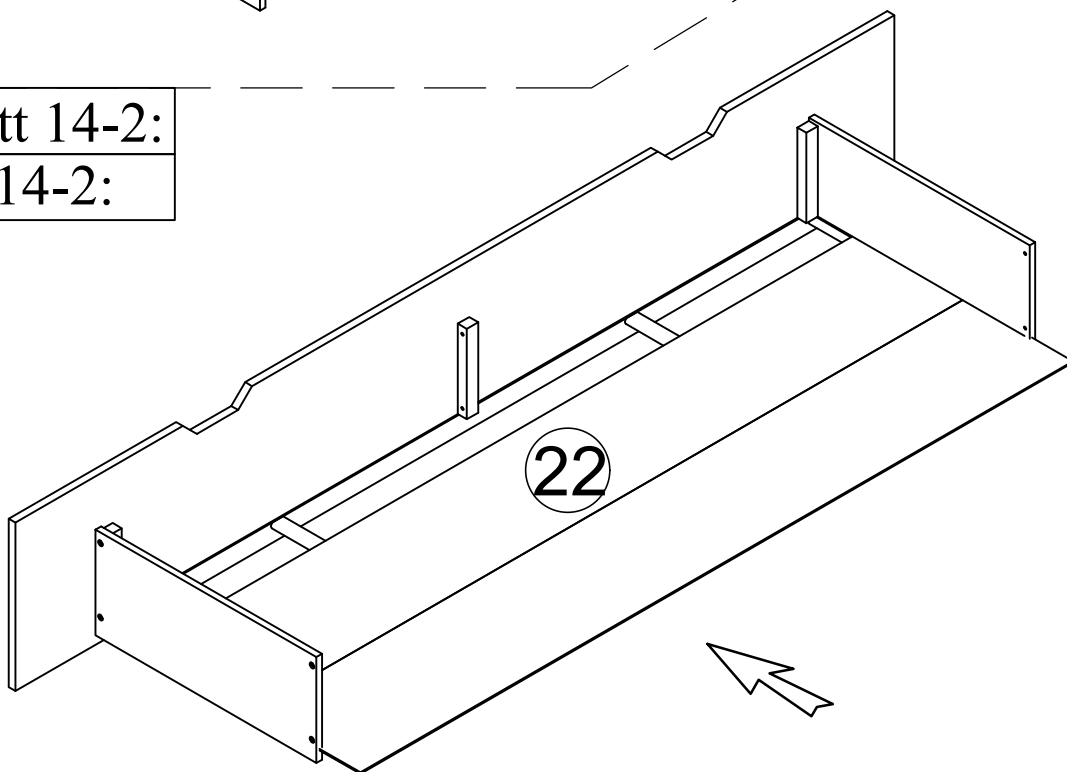

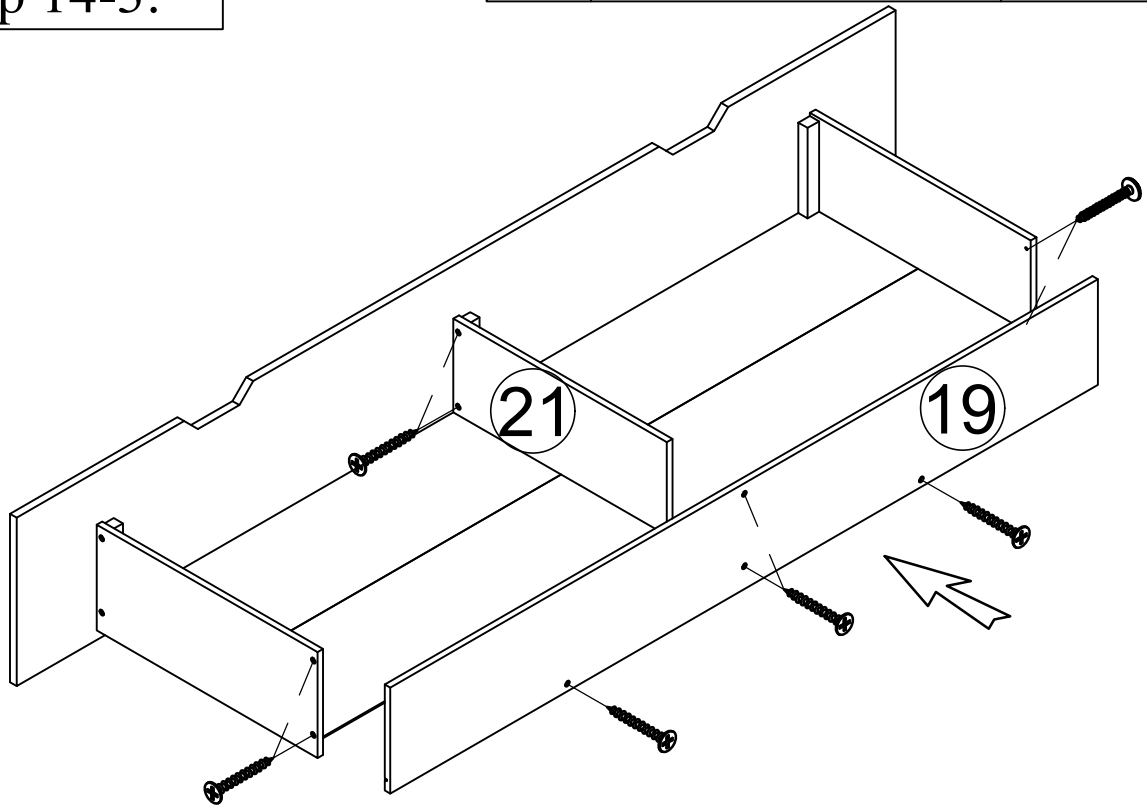

Schritt 14-3:
Step 14-3:

H		M4 x 30	10 pcs
---	---	---------	--------



Schritt 14-4:
Step 14-4:

K		H=28	4
F		M4 x 15	8

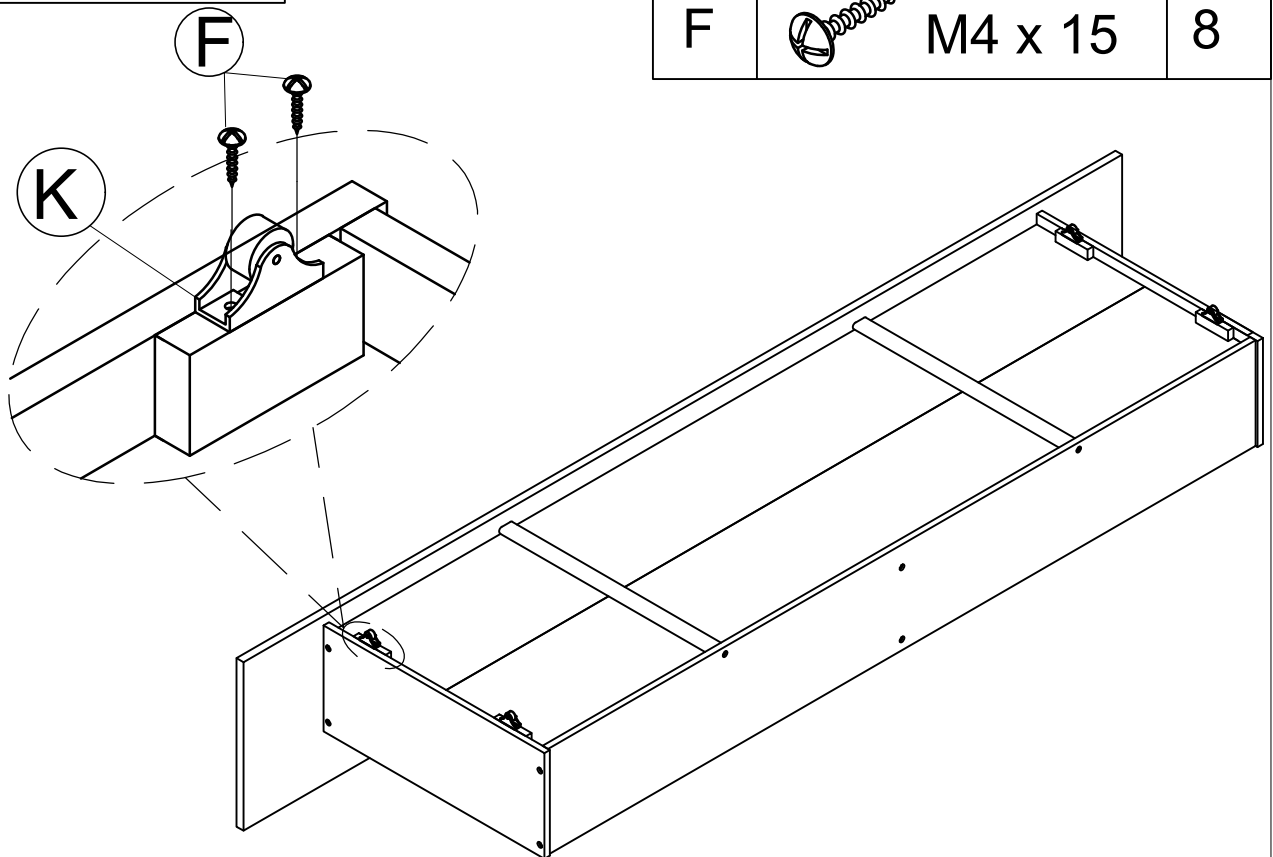

Schritt 15:

Step 15:

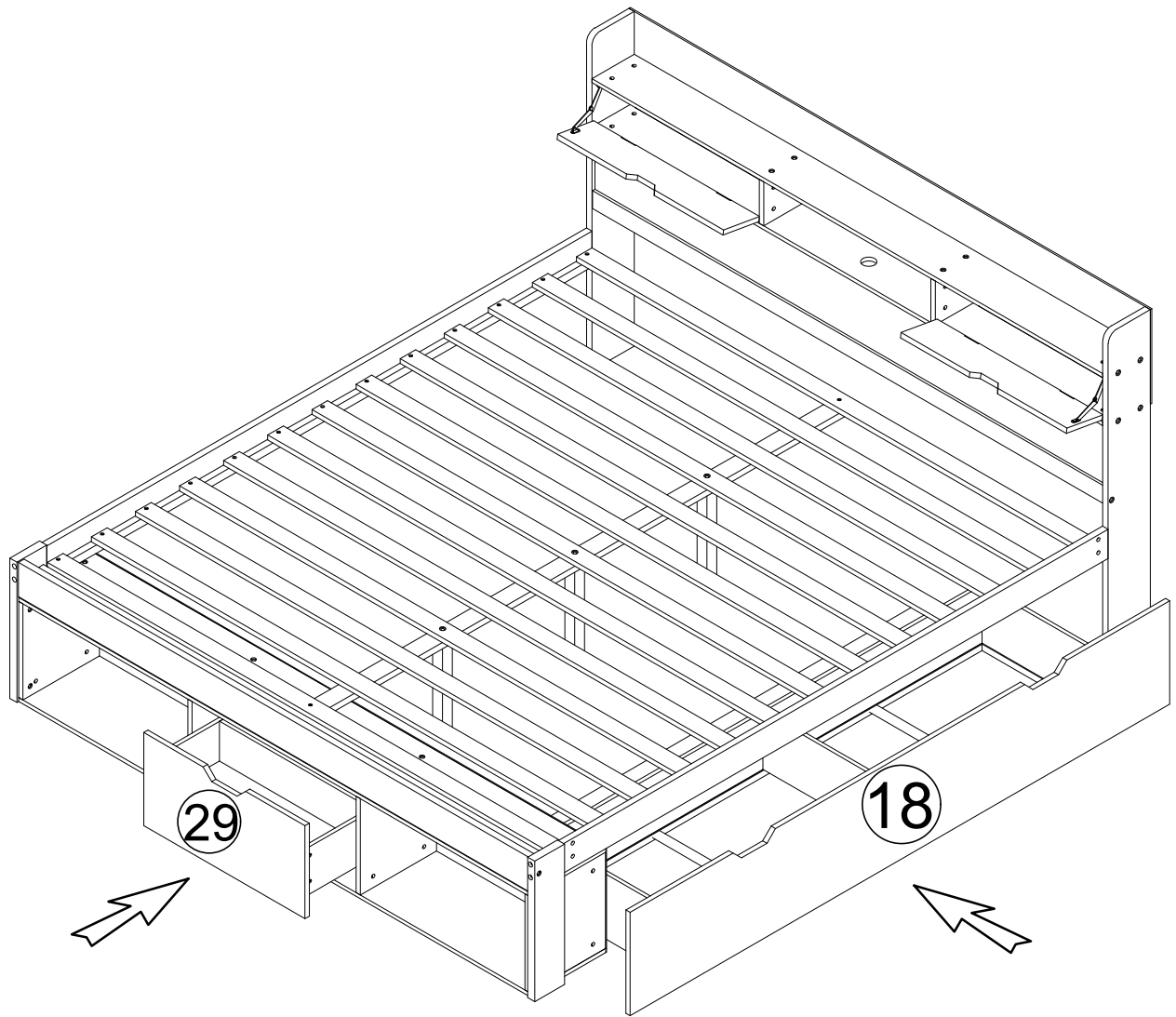

Schritt 16:

Step 16:

N



Usb Power

1 pc

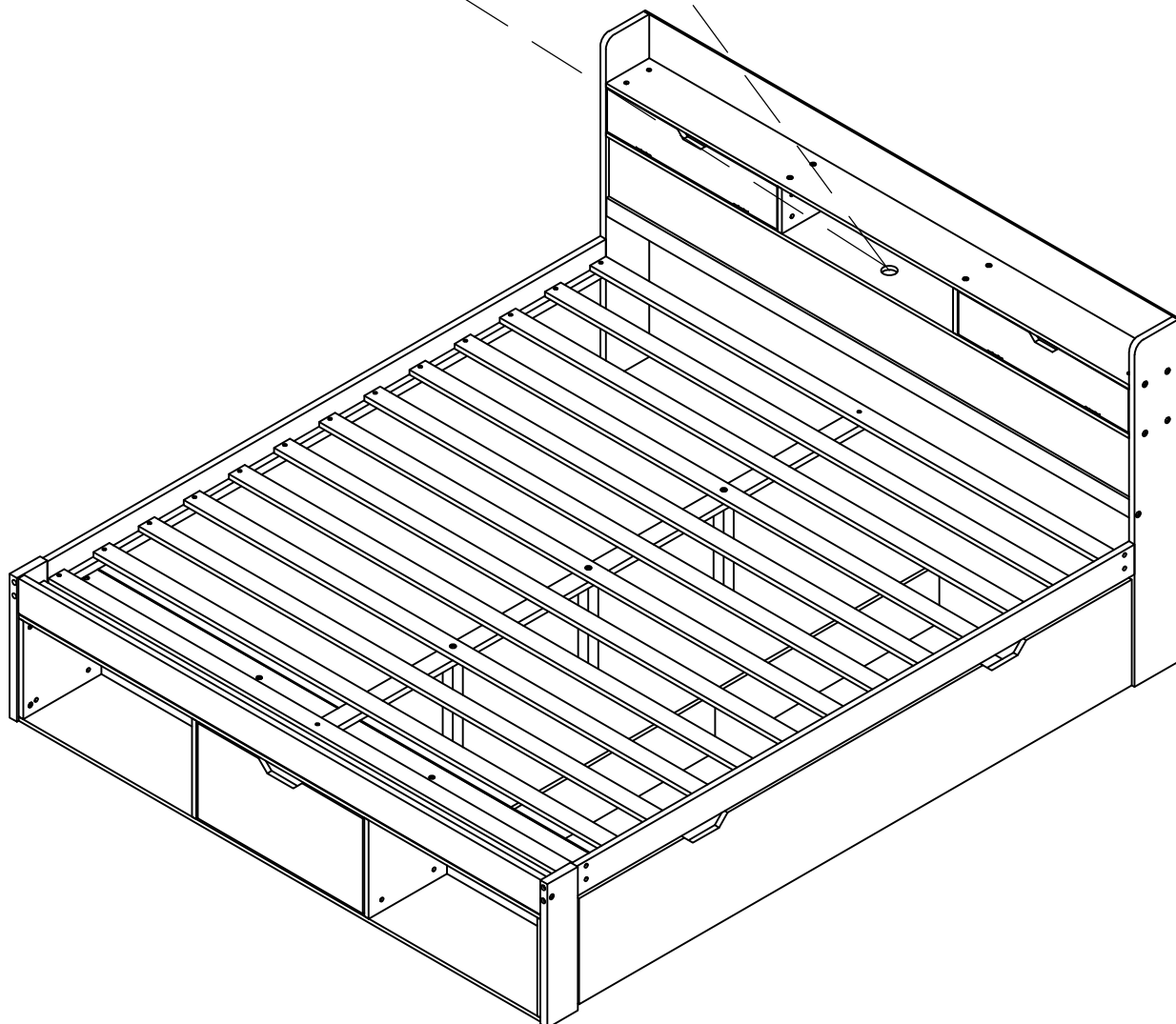
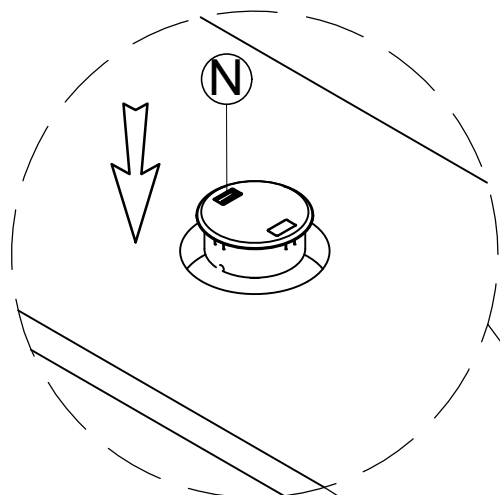



CERTIFICATE OF CONFORMITY

Electromagnetic Compatibility (EMC) Directive 2014/30/EU

This Certificate of Conformity is hereby issued to the product designated below:

Certificate No...... : 23EP08001E01

Report No...... : EP2308001E01

Date Issue...... : 2023-08-23

Applicant's name..... : DA TANG LIGHT TECHNOLOGY CO.,LTD

Address..... : No.688, KP4, AnFu Electronic Industrial, Shun's County Binh Duong

Manufacturer's name..... : DA TANG LIGHT TECHNOLOGY CO.,LTD

Address..... : No.688, KP4, AnFu Electronic Industrial, Shun's County Binh Duong

Product Description..... : Socket

Model(s)/Type References : DT-XXXX(The 1st "X" represents the switch, 0-1, the 2nd "X" represents the number of sockets 1-4, the 3th "X" represents the number of USB 1-3 (1 is double A, 2 is A+C,3 is double C), and the 4th "X" represents the wireless charge 0-1)

Parameters..... : See attachment for details

Standard(s)..... : EN 55032:2015+A11:2020+A1:2020
EN 55035:2017+A11:2020
EN IEC 61000-3-2:2019+A1:2021
EN 61000-3-3:2013+A1:2019+A2:2021

On the basis of the referenced test report(s), sample(s) tested of the above product have been found to comply with the standards harmonized with the directives listed on this verification at the time the tests were carried out. Other standards and Directives may be relevant to the product. This verification is part of the full test report(s) and should be read in conjunction with it(them).

Once compliance with all product relevant CE mark directives are verified, including any relevant e.g. risk assessment and production control, the manufacturer may indicate compliance by signing a Declaration of Conformity themselves and applying the mark to products identical to the tested sample(s).

Approved By

Eric Liu

Director of engineering department

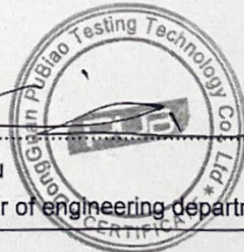

Dongguan Pubiao Testing Technology Co., Ltd

No. 3, 1/F., Building A, No.30, Minghua Road, Juzhou, Shijie, Dongguan, Guangdong, China

Tel: +86 769 81813516 E-mail: service@pubiaotest.com Web: www.pubiaotest.com



CERTIFICATE OF CONFORMITY

Electromagnetic Compatibility (EMC) Directive 2014/30/EU

Appendix of Certificate No.: 23EP08001E01

Parameters:

Input: 220-250Vac, 50Hz, 10A

Output: AC socket: 2500W max

1)For USBA+Type-C output:

Type-C: 5VDC3A/9VDC2.22A/12VDC1.67A

USBA:5VDC3A/9VDC2A/12VDC1.5A

Type-C&USB: 5VDC/3A

Wireless:15W max

2)For double C output:

Type-C1: 5VDC3A/9VDC2.22A/12VDC1.67A

Type-C2:5VDC3A/9VDC2A/12VDC1.5A

Type-C1&Type-C2: 5VDC/3A

Wireless:15W max

3)For double A output:

USBA1:5VDC 2.1A

USBA2:5VDC 2.1A

USBA1&USBA2:5VDC/2.1A

Wireless:15W max



Dongguan Pubiao Testing Technology Co., Ltd

No. 3, 1/F., Building A, No.30, Minghua Road, Juzhou, Shijie, Dongguan, Guangdong, China

Tel: +86 769 81813516 E-mail: service@pubiaotest.com Web: www.pubiaotest.com