

# MONTAGEANLEITUNG

WF310429AAB WF310430AAB  
WF310429AAG WF310430AAG

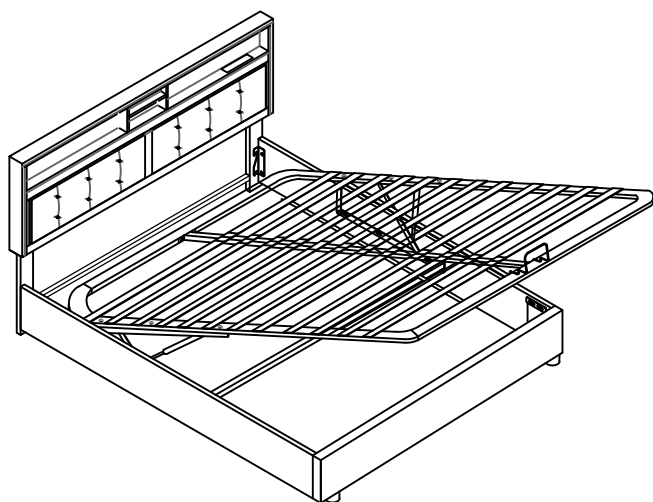

Please check that you have all the parts listed before you start assembling, if you do find that something is missing, do not continue assembly, please contact us immediately.

NOTE: Please do not completely tighten all the hardware until the entire assembly is complete!

Bitte überprüfen Sie, ob alle Teile mitgeliefert sind, bevor Sie mit der Montage beginnen. Wenn Sie festlegen, dass etwas fehlt, setzen Sie die Montage nicht fort. Bitte kontaktieren Sie uns sofort.

Achtung: Bitte ziehen Sie nicht alle Schrauben fest, bevor die Montage abgeschlossen ist!

**D** Gebrauchsanweisung

**NL** Gebruiksrichtlijnen

**IT** Istruzioni per l'uso

**CZ** Pokyny k použití

**HU** Használati útmutató

**PT** Instruções de utilização

**SK** Pokyny k použitiu

**GB** Instructions for use

**FR** Instructions d'utilisation

**PL** Instrukcja obsługi

**ES** Instrucciones de empleo

**RO** Instrucțiuni de folosire

**RU** Инструкция по монтажу

**TR** Kullanım talimatları

This set will be shipped by 2 boxes and they may arrive on different days. If both packages arrived but parts missing, please contact customer service.

Dieses Set ist in 2 Boxen enthalten. Wenn Sie keine vollen 2 Boxen erhalten, wenden Sie sich bitte an unseren Kundenservice

Cet ensemble sera expédié en 2 colis et ils peuvent arriver les jours différents. Si les deux colis sont arrivés mais des pièces sont manquantes, veuillez contacter le service client.

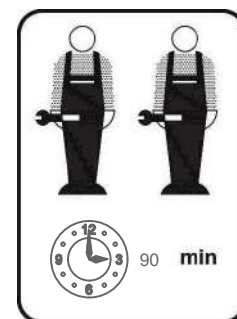

**FR - Notice de montage / EN - Assembly instructions / PT - Instruções de montagem /  
ES - Prospecto de montaje / DE - Montageanleitung / IT - Istruzioni di montaggio /  
NL - Montagehandleiding**

**FR - IMPORTANT! CONSERVER POUR CONSULTATION ULTERIEURE: LIRE ATTENTIVEMENT**

- A monter par un adulte. Un adulte doit vérifier le bon assemblage avant l'emploi
- ATTENTION! tenir les vis et petits éléments et sachets hors de portée des enfants
- Bien identifier les éléments avant de commencer le montage
- Ne pas utiliser votre article lorsque l'un de ses éléments est cassé ou manquant
- En cas de problème contactez notre service après-vente
- Toujours suivre les instructions du fabricant
- Entretien: nettoyer avec un chiffon doux et sec. En cas de taches plus grosses, frottez soigneusement avec une éponge légèrement humide et non abrasive
- Ne pas sauter sur le lit

**EN - IMPORTANT! KEEP FOR FUTURE REFERENCE: READ CAREFULLY**

- To be assembled by an adult. Assembly must be checked by an adult before use
- WARNING! keep all screws, small parts and plastic bags out of the reach of children
- Properly identify all parts before assembling
- Never use your item if any of its parts are broken or missing
- Should any problems arise, please contact our After Sales Service
- Manufacturer's instructions shall be followed at all times
- Care: clean with a soft, dry cloth. In case of larger stains, carefully rub with a slightly damp, non-abrasive sponge
- Do not jump on the bed

**PT - IMPORTANTE! GARDE PARA CONSULTA POSTERIOR: LER ESTAS INSTRUÇÕES CUIDADOSAMENTE**

- A ser montado por um adulto. Um adulto deve verificar a boa montagem antes da utilização
- Atenção! mantenha os parafusos, acessórios pequenos e saco de plástico fora do alcance das crianças
- Identifique bem os acessórios antes de começar a montagem
- Não utilizar o artigo se um dos elementos está em falta ou danificado
- Para qualquer esclarecimento, contacte os nossos serviços através do telefone
- As instruções do fabricante devem ser sempre cumpridas
- Manutenção: limpe com um pano macio e seco. Em caso de manchas maiores, esfregue cuidadosamente com uma esponja ligeiramente húmida e não abrasiva
- Não salte na cama

**ES - IMPORTANTE! CONSERVAR PARA FUTURAS CONSULTAS: LEER DETENIDAMENTE**

- A montar por un adulto. Un adulto debe comprobar el buen montaje antes de la utilización
- ¡ADVERTENCIA! mantener los tornillos, los pequeños elementos y bolsitas fuera del alcance de los niños
- Identificar debidamente los elementos antes de empezar el montaje
- No utilizar este artículo si uno de los elementos falta o esta roto
- Si tiene problemas, contactar nuestro servicio postventa
- Deben seguirse siempre las instrucciones del fabricante Cuidados: limpiar con un paño suave y seco. En caso de manchas grandes, frotar con cuidado utilizando una esponja húmeda no abrasiva
- No saltar sobre la cama

**DE - WICHTIG! FÜR SPÄTERE BEZUGNAHME AUFBEWAHREN: SORGFÄLTIG LESEN**

- Von einem Erwachsenen zu montieren. Die korrekte Montage muss vor Gebrauch von einem Erwachsenen geprüft werden
- Achtung! die Schrauben und kleinen Teile ausserhalb der Reichweite von Kindern lagern
- Vor Montagebeginn alle Teile identifizieren
- Ihren Artikel nicht benutzen, wenn eines seiner Bestandteile beschädigt ist oder fehlt
- Im Problemfall Ihren Kundendienst anrufen
- Stets die Herstelleranweisungen beachten
- Wartung: Mit einem weichen, trockenen Tuch reinigen. Bei größeren Flecken vorsichtig mit einem leicht feuchten, nicht scheuernden Schwamm abreiben
- Nicht auf dem Bett springen

**IT - IMPORTANTE! CONSERVARE QUESTE INFORMAZIONI PER ULTERIORI CONSULTAZIONI: LEGGI ATTENTAMENTE**

- Il montaggio deve essere eseguito da un adulto. Un adulto dovrà verificare il corretto montaggio prima dell'uso
- ATTENZIONE! tenere le viti ed i componenti di piccole dimensioni lontano dalla portata dei bambini
- Controllare i pezzi prima del montaggio
- L'articolo non deve essere utilizzato in caso di elementi mancanti o danneggiati
- In caso di necessità contattare il nostro servizio post-vendita
- Seguire sempre le istruzioni del costruttore
- Manutenzione: pulire con un panno morbido e asciutto. Per le macchine più grandi, strofinare accuratamente con una spugna leggermente umida e non abrasiva
- Non saltare sul letto

**NL - BELANGRIJK! BEWAAR VOOR LATERE RAADPLEGING: LEES AANDACHTIG**



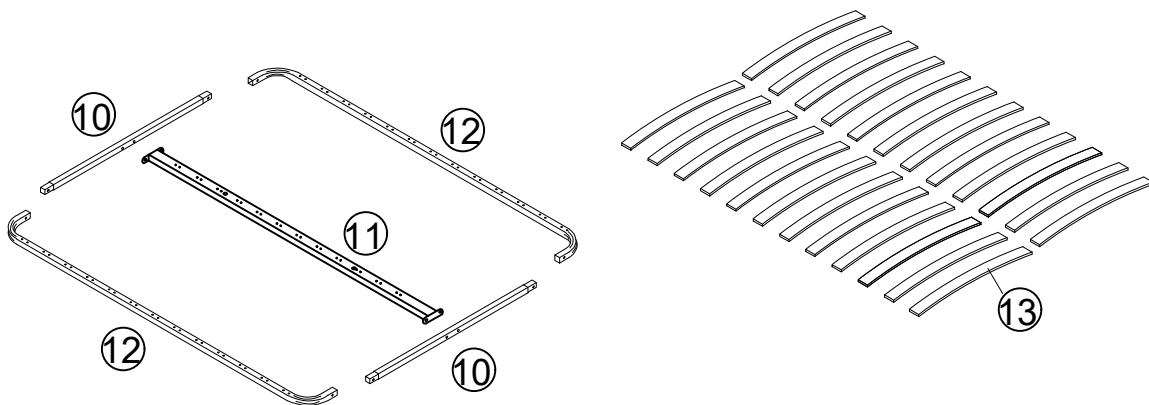
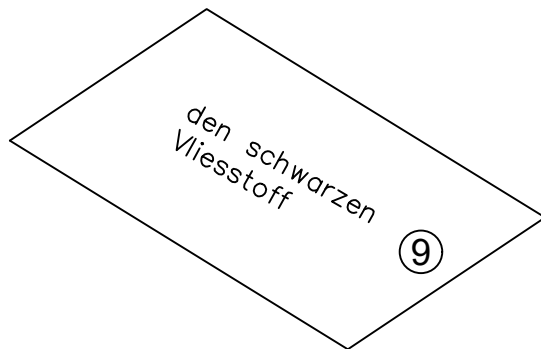
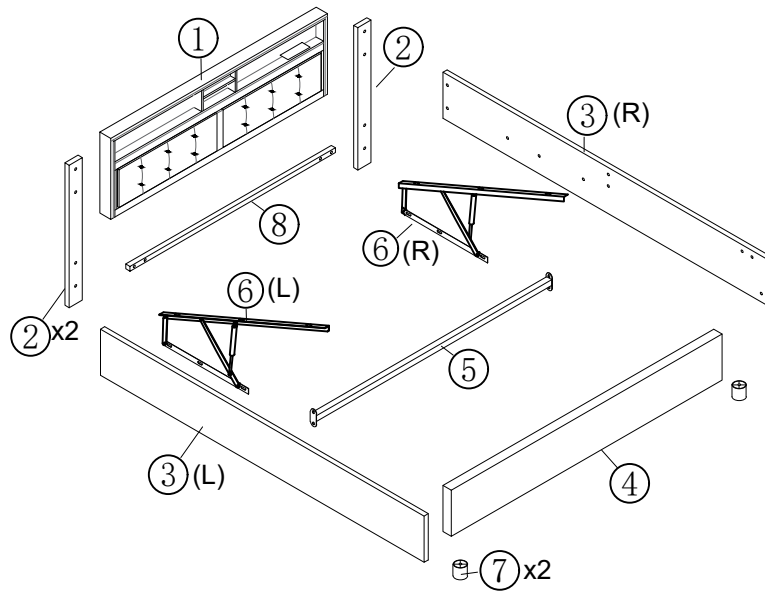

- Moet door een volwassene worden gemonteerd. Voor gebruik moet een volwassene controleren dat het product goed in elkaar is gezet
- WAARSCHUWING! schroeven en kleine elementen en zakjes buiten bereik van kinderen houden
- De elementen goed identificeren alvorens met de montage te beginnen
- Uw artikel niet gebruiken wanneer een van de onderdelen kapot is of ontbreekt
- Neem bij problemen contact op met onze klantenservice
- Volg altijd de instructies van de fabrikant
- Onderhoud: maak schoon met een zachte en droge doek. In geval van grotere vlekken, veeg voorzichtig schoon met een licht bevochtigde en niet-schurende spons
- Niet springen op het bed

# Stückliste



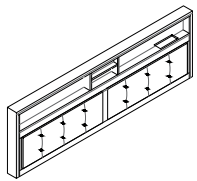

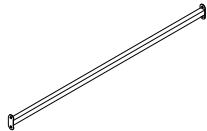
## Part List-Stückliste

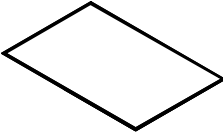
### WF310429AAB / WF310429AAG

<p>①x1</p> 	<p>②x2</p> 	<p>⑤x1</p> 
<p>⑥x2</p> 	<p>⑨x1</p> 	



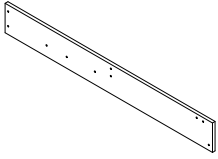
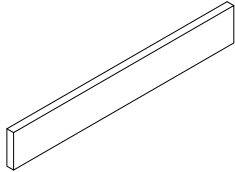

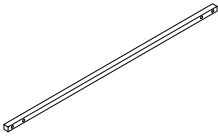
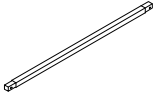
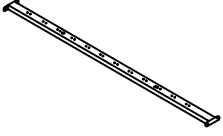
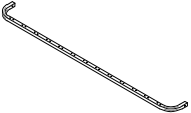
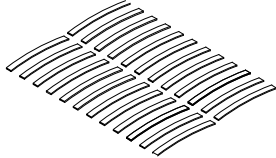



## Part List-Stückliste

### WF310430AAB / WF310430AAG

<p>③x2</p> 	<p>④x1</p> 	<p>⑦x2</p> 
<p>⑧x1</p> 	<p>⑩x2</p> 	<p>⑪x1</p> 
<p>⑫x2</p> 	<p>⑬x24</p> 	

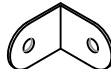
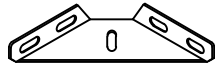
# Hardware List- Hardware-Liste

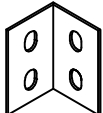
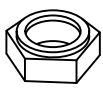
WF310430AAB / WF310430AAG

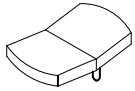
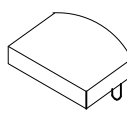
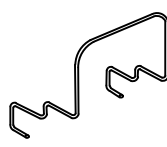
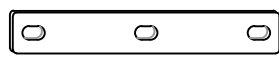
<p>A x1</p> 	<p>B x18</p>  <p>M8x45mm</p>	<p>C x2</p> 
<p>D x38</p>  <p>M8x18mm</p>	<p>E x2</p> 	<p>F x2</p> 
<p>G x2</p>  <p>M4x50mm</p>	<p>H x1</p> 	<p>I x4</p> 
<p>J x1</p> 	<p>K x14</p> 	<p>L x12</p> 
<p>M x24</p> 	<p>N x1</p> 	<p>O x2</p> 

## Step 1

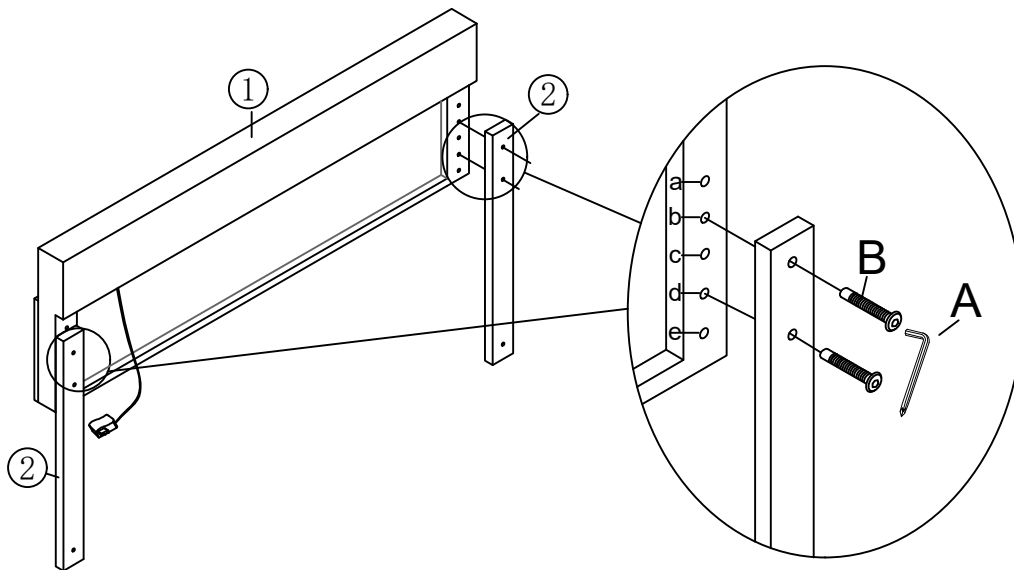

Headboard height is Adjustable  
 Kopfteil ist Höhe-einstellbar  
 La hauteur de la tête de lit est réglable

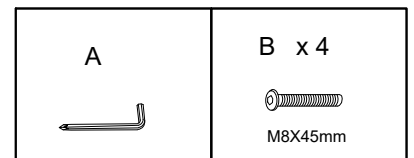

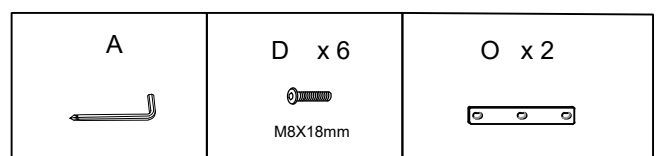
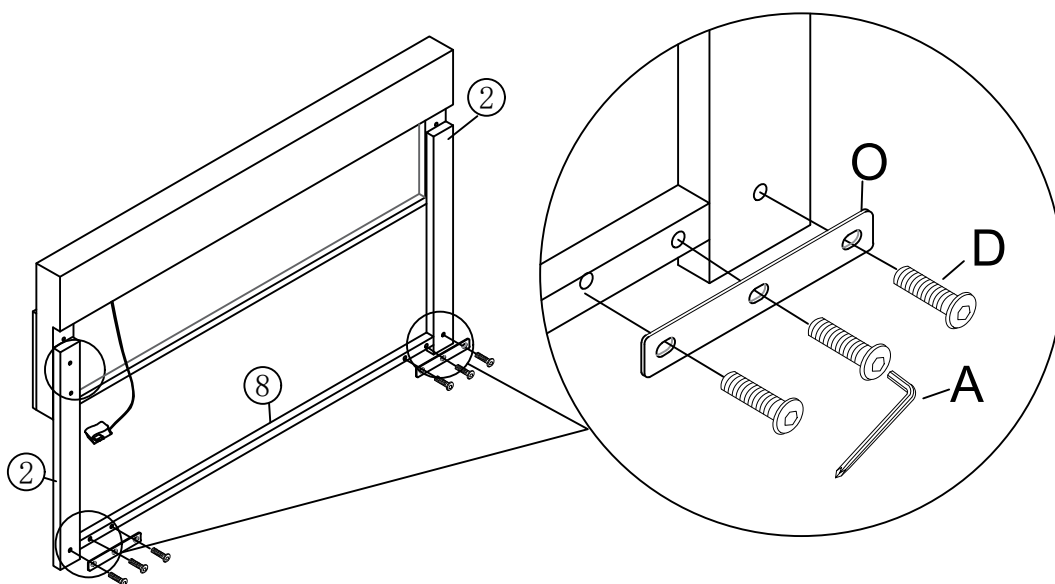

## Step 2



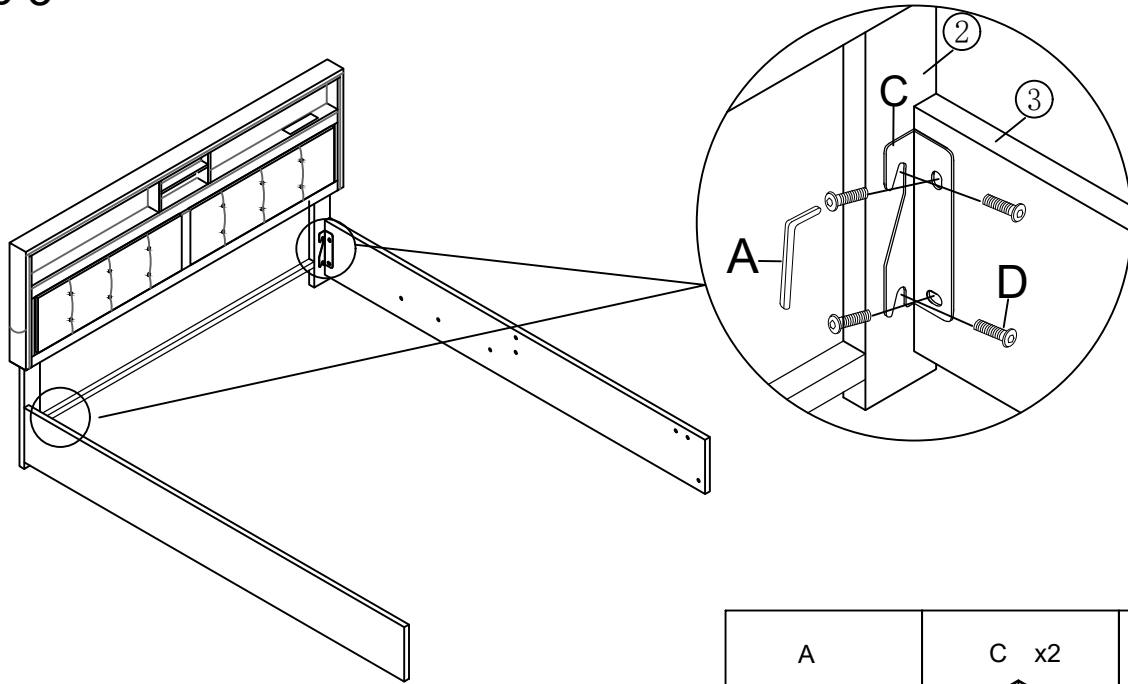



### Step 3

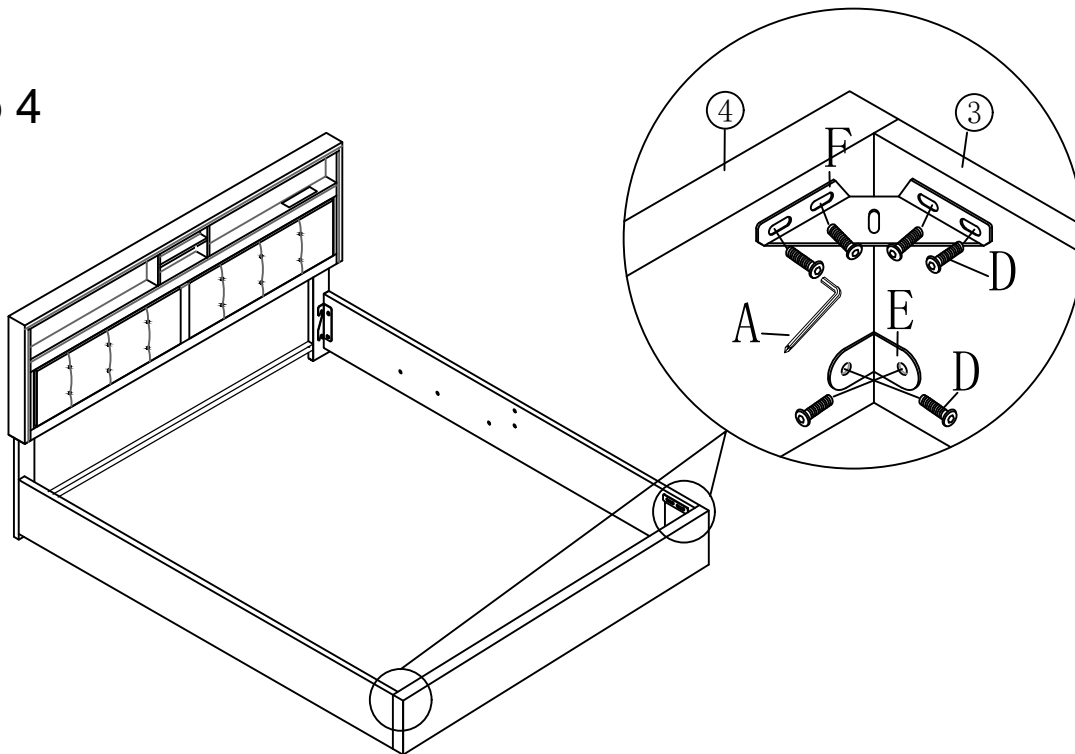

A	C x2	D x 8
		
		M8X18mm

### Step 4

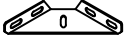

A	D x 12	E x 2	F x 2
			
	M8X18mm		

# Step 5

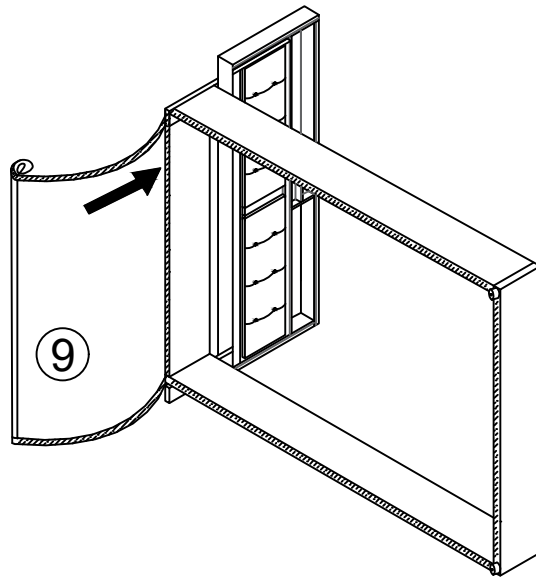

# Step 6

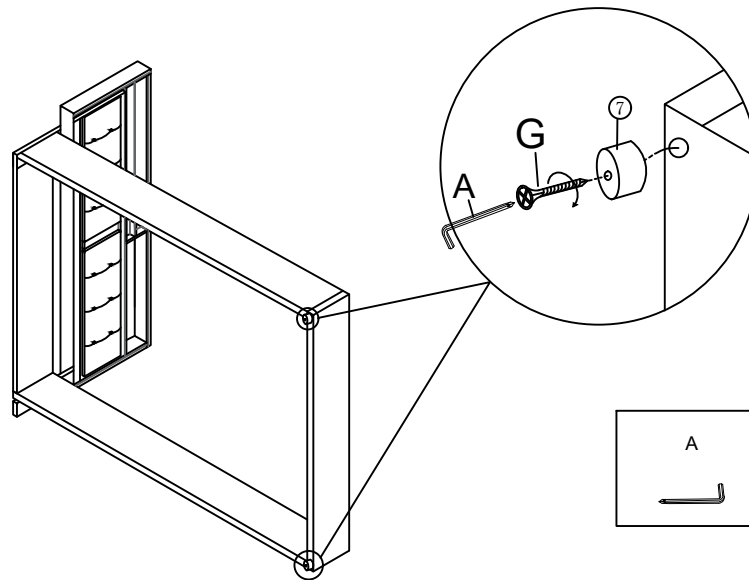

# Step 7

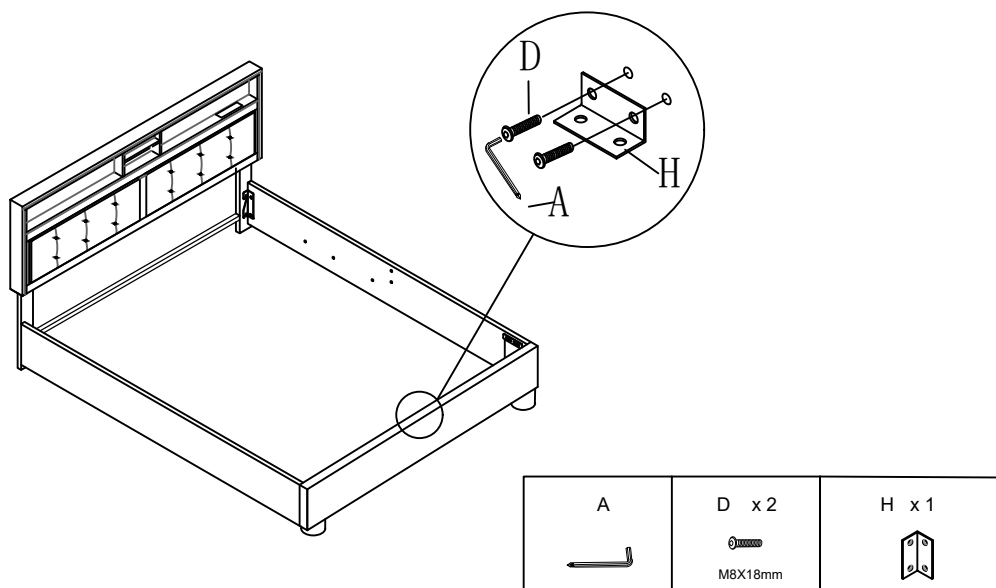



## Step 8

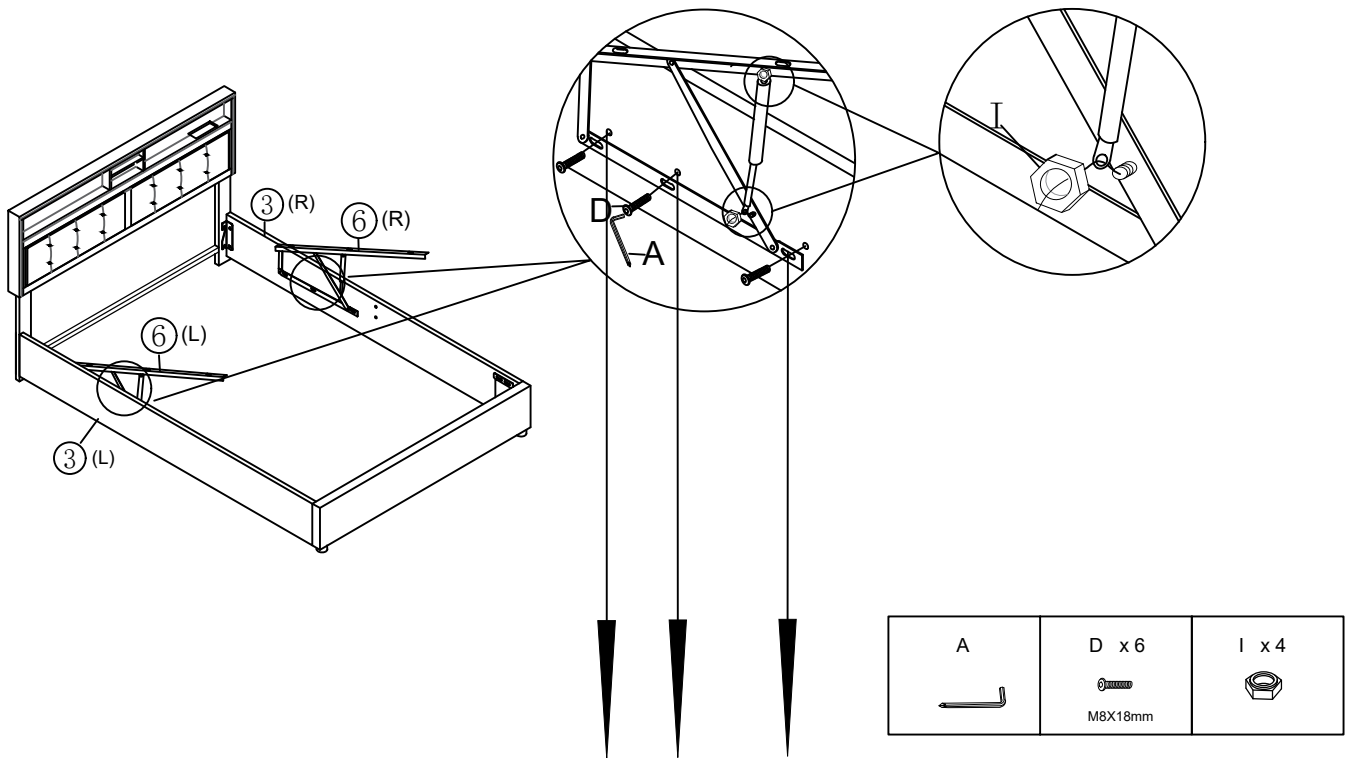

Please note that the hole position here is oval, and the screw can be adjusted back and forth. Please ensure that the position of the left and right bedside hydraulic rods is roughly always.

Please don't install one screw at the front of the hole and the other at the back of the hole, as this will affect the movement of the slat frame.

Bitte beachten Sie, dass die Lochposition hier oval ist und die Schraube hin und her verstellbar ist. Bitte achten Sie darauf, dass die Position der linken und rechten bettseitigen Hydraulikstangen immer ungefähr ist.

Bitte montieren Sie nicht eine Schraube vorne am Loch und die andere hinten am Loch, da dies die Bewegung des Lattenrostes beeinträchtigt.



Veuillez noter que la position du trou ici est ovale et que la vis peut être ajustée d'avant en arrière. Veuillez vous assurer que la position des tiges hydrauliques de chevet gauche et droite est à peu près toujours. Veuillez ne pas installer une vis à l'avant du trou et l'autre à l'arrière du trou, car cela affectera le mouvement du cadre de lattes.

Veuillez noter que la position du trou ici est ovale et que la vis peut être ajustée d'avant en arrière. Veuillez noter que la position des tiges hydrauliques de chevet gauche et droite est toujours approximative.

Veuillez ne pas installer une vis à l'avant du trou et l'autre à l'arrière du trou, car cela affectera le mouvement du sommier.

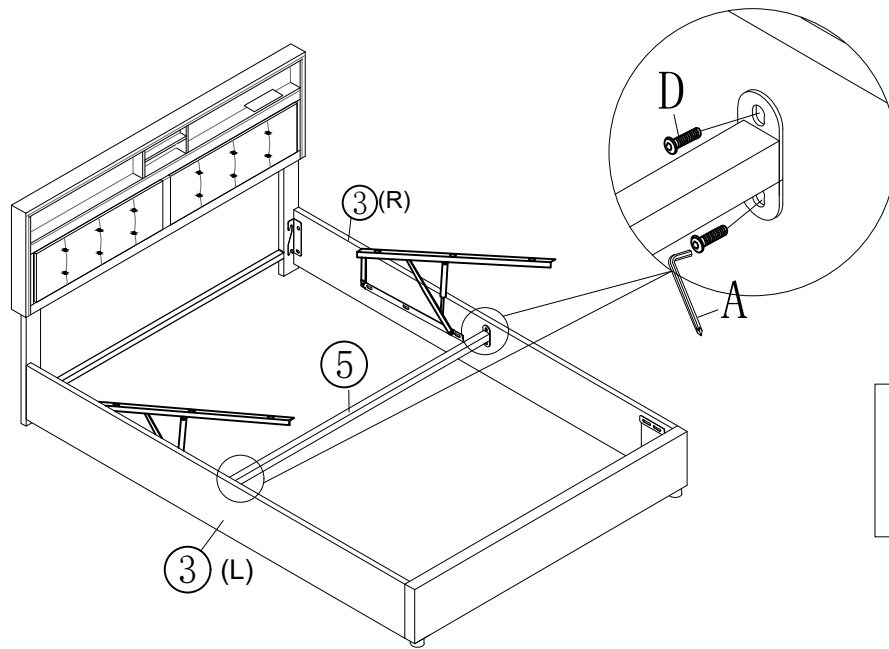



# Step 9

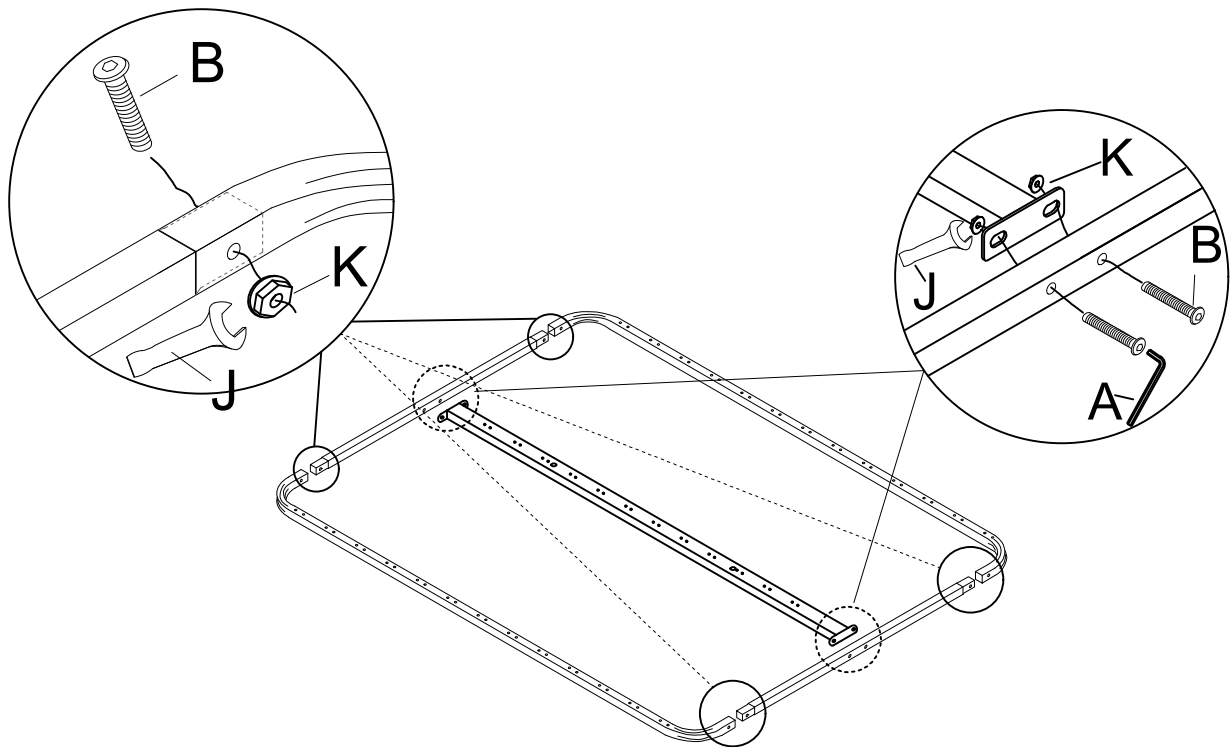

A	D x 4
	 M8X18mm

# Step 10



A	B x 8	K x 8	J x 1
	 M8X45mm		

## Step 11

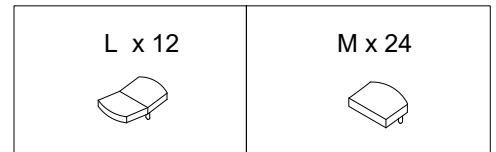
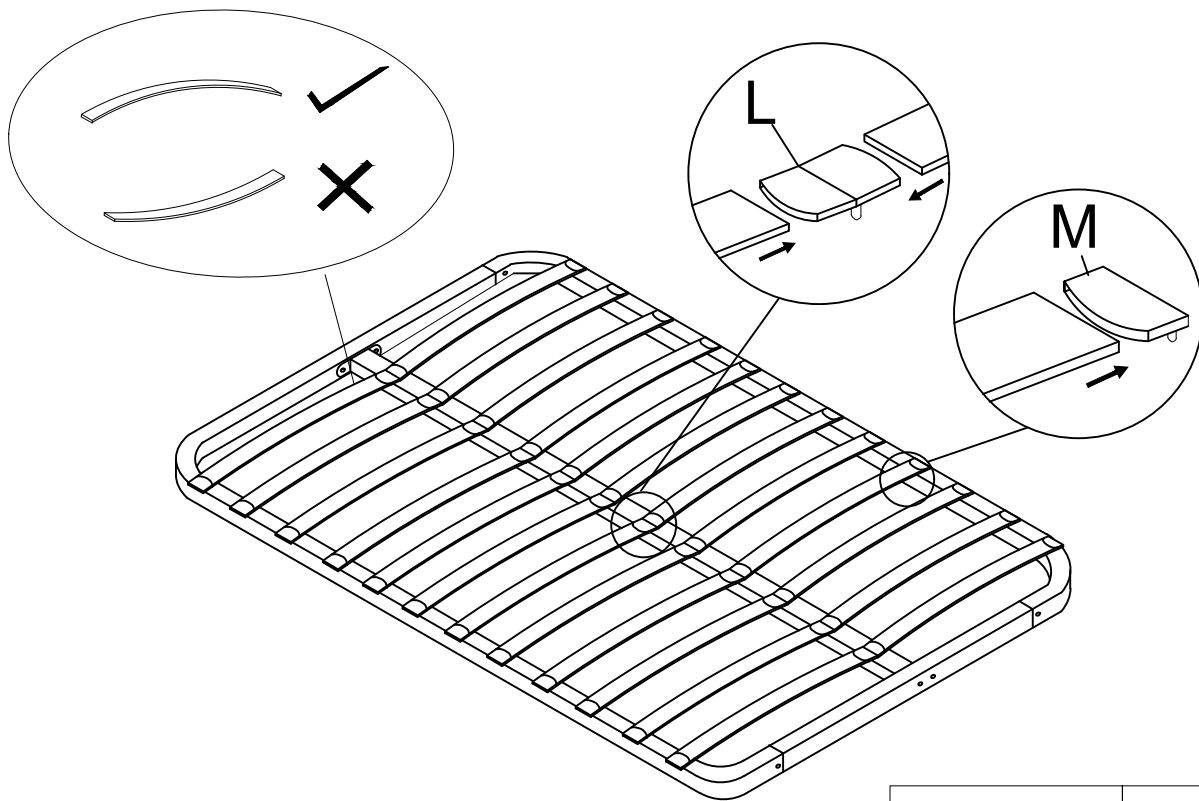

## Step 12

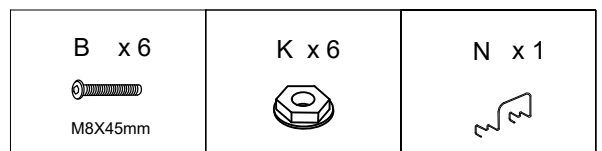
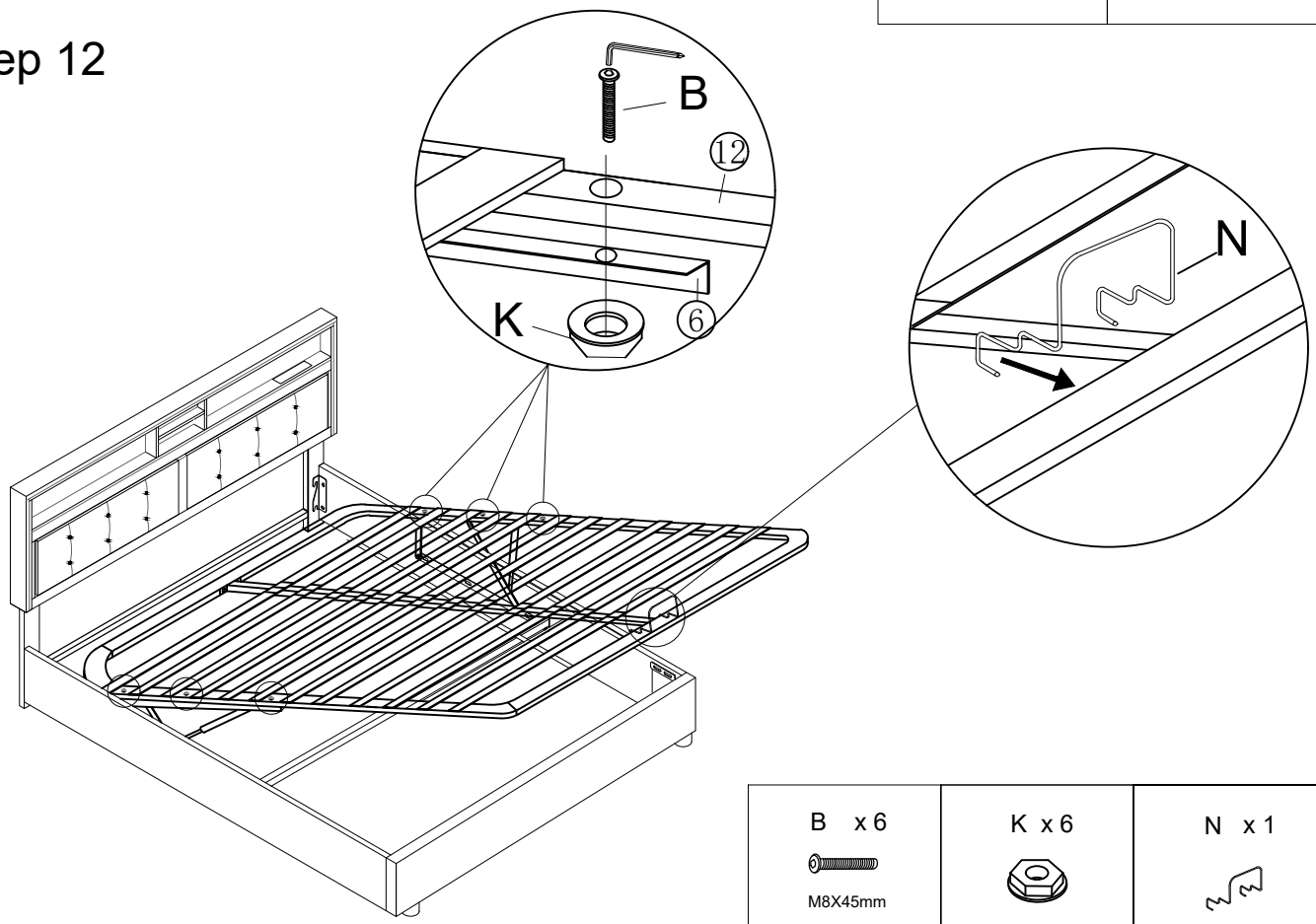

# Step 13

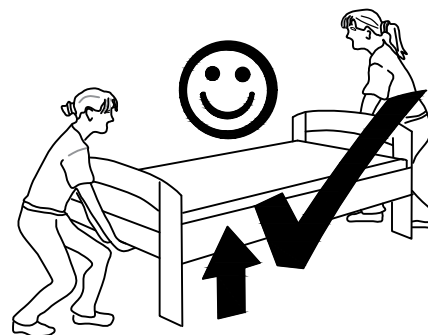
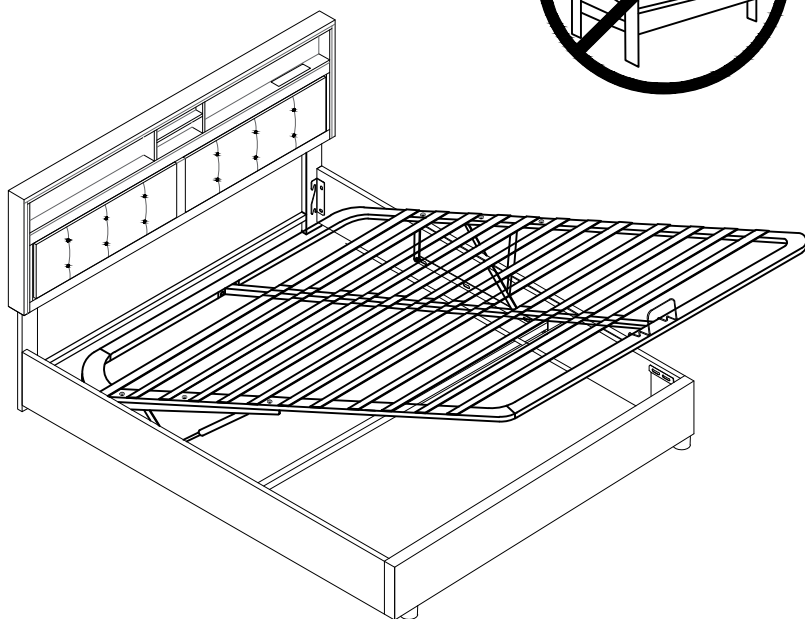
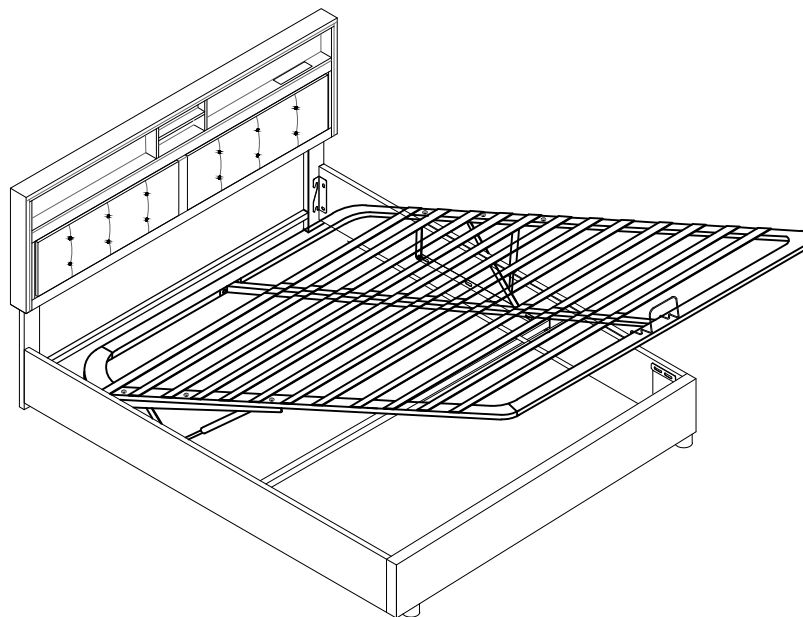

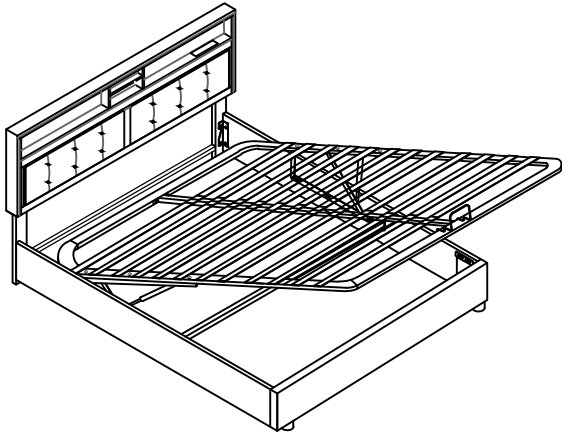

#### WHY WON'T MY HYDRAULIC BED STAY DOWN?

1. In fact, nine times out of ten the reason why hydraulic won't close is because you need to put your mattress on top of the bed. Yep, it really is that easy. This is because the hydraulic pistons need the weight of the mattress to provide enough pressure to close your bed.
2. However, what if you've put your mattress on your bed and you're one of the unlucky ones who finds that their hydraulic bed still won't stay down? As previously mentioned, they require pressure in order to close. However, occasionally as well as placing the mattress on the bed you will initially have to apply some physical force yourself to close the bed. Don't worry you won't break it! ! ! !

#### WARUM BLEIBT MEIN HYDRAULISCHES BETT NICHT UNTEN?

1. In neun von zehn Fällen liegt der Grund dafür, dass sich die Hydraulik nicht schließen lässt, darin, dass Sie Ihre Matratze oben auf das Bett legen müssen. Ja, es ist wirklich so einfach. Das liegt daran, dass die Hydraulikkolben das Gewicht der Matratze benötigen, um genügend Druck zum Schließen des Bettes zu erzeugen.
2. Was aber, wenn Sie Ihre Matratze auf Ihr Bett gelegt haben und zu den Unglücklichen gehören, die feststellen, dass ihr hydraulisches Bett trotzdem nicht unten bleibt? Wie bereits erwähnt, muss man Druck ausüben, um sie zu schließen. Gelegentlich müssen Sie jedoch nicht nur die Matratze auf das Bett legen, sondern zunächst selbst etwas Kraft aufwenden, um das Bett zu schließen. Keine Sorge, Sie werden es nicht kaputt machen! ! ! !

#### Pourquoi mon lit hydraulique ne peut pas être abaissé

1. En fait, huit sur dix Les raisons pour lesquelles les unités hydrauliques ne peuvent pas être fermées sont Parce que vous devez mettre un matelas Dans le lit. Oui, en effet Si simple. C'est parce que Piston hydraulique requis Le matelas fournit suffisamment La pression de fermer votre lit.
2. Cependant, si vous mettez Matelas sur votre lit, vous êtes un Les malheureux ont découvert Leur lit hydraulique ne sera toujours pas Allongé? Comme mentionné précédemment, ils ont besoin de Pour fermer. Cependant Occasionnellement et placement Matelas sur le lit Certaines forces physiques doivent être appliquées Fermez le lit vous - même. Ne pas Peur de ne pas le casse! ! ! !

## IMPORTANT NOTICE

### OTTOMAN OPERATING INSTRUCTIONS

Once your bed frame is completely assembled, the slat unit will not operate correctly unless a mattress is placed on the slat frame. Position the mattress on the slat frame whilst it is in the closed position.

PLEASE NOTE - It takes a lot of force to make the initial movement of the ottoman. This is a design feature of the product so that it does not fall shut - the nearer to being closed the ottoman is, the easier it is to move. When the ottoman is almost shut, it will close completely under its own weight.

When lowering the slat unit for the first time, take care to make sure it does not rub unevenly on the inside face of the side rails. If it does, the bed has been assembled slightly out of square. This can be rectified by moving the foot end of the bed slightly to the left or right whilst leaving the head end stationary.

### PISTONS

The pistons used in the construction of this product are extremely strong and cannot be operated by hand when taken off the ottoman. All pistons are tested for correct pressure and operation before being attached to the slat unit.

Initially it might appear that the pistons are very stiff when opening and closing the ottoman.

### THIS IS PERFECTLY NORMAL

When fully assembled and the mattress is in position, please raise and lower the ottoman 4/5 times to ensure the gas piston are fully lubricated.

