

welltime

Art. Nr. 9841 1021

HN303-TSC

L

R

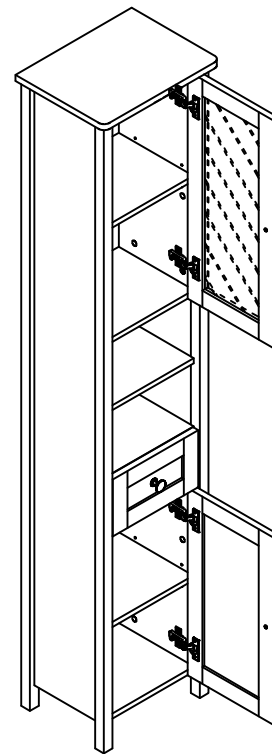
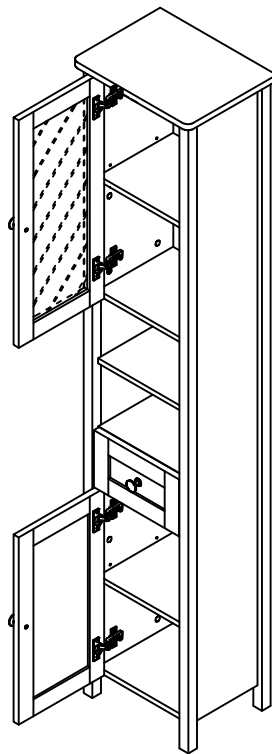

- | | |
|---|-------------------------------------|
| (D) Montageanleitung | (GB) Assembly instructions |
| (FR) Notice de montage | (IT) Istruzioni di montaggio |
| (NL) Handleiding voor de montage | (PL) Instrukcja montazu |
| (CZ) Montážní návod | (SK) Návod na montáž |
| (HU) Szerelési útmutató | (RO) Instrukțiuni de montaj |
| (TR) Montaj talimati | (RU) Инструкция по монтажу |

Ausgabe:20220909

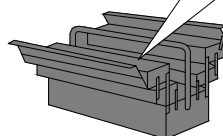
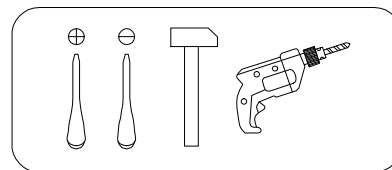
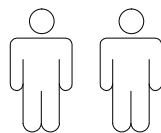

**Sicherheitshinweise • Safety instructions • Consignes de sécurité •
 Norme di sicurezza • Veiligheidsinstructies • Wskazówki bezpieczeństwa •
 Bezpečnostní pokyny • Bezpečnostné pokyny • Biztonságtechnikai
 tudnivalók • Instrucțiuni referitoare la siguranță • Güvenlik uyarıları •**

1	D	Beschädigungsgefahr! Gehen Sie bei der Montage des Artikels sorgfältig vor und halten Sie sich an die Montageanleitung. Der Artikel darf nur von fachkundigen Personen montiert werden.
	GB	Risks of damage! When assembling the product, please proceed with caution and comply with the assembly instructions. The product may only be assembled by persons with the necessary knowledge and competence.
	FR	Risque d'endommagement ! Lors du montage de l'article, procédez avec minutie et respecter les indications de la notice de montage. L'article ne pourra être monté que par des personnes spécialisées.
	IT	Pericolo di danneggiamenti! Assemblando l'articolo procedere con prudenza ed attenersi alle istruzioni di montaggio. L'articolo può essere assemblato solo da persone esperte.
	NL	Risico op beschadiging! Ga bij de montage van het artikel zorgvuldig te werk en houd u aan de handleiding voor de montage. Het artikel mag alleen worden gemonteerd door vaklui.
	PL	Niebezpieczeństwo uszkodzenia! Podczas montażu proszę postępować z należytą uwagą i zgodnie z instrukcją montażu. Artykuł może być montowany tylko przez osoby z odpowiednimi kwalifikacjami.
	CZ	Nebezpečí poškození! Při montáži výrobku postupujte pečlivě a dodržujte pokyny uvedené v montážním návodu. Montáž výrobku smí provádět pouze odborníci.
	SK	Nebezpečenstvo poškodenia! Pri montáži výrobku postupujte obozretne a dodržujte návod na montáž. Montáž výrobku smie vykonať len odborník.
	HU	Sérülésveszély! A termék összeszerelésekor körültekintően járjon el, és tartsa magát a szerelési útmutatóban foglaltakhoz. A terméket csak műszaki területen jártas személy szerelheti össze.
	RO	Pericol de deteriorare! Procedați cu atenție la montarea produsului și respectați instrucțiunile de montaj. Produsul se montează numai de către personal competent.
	TR	Hasar oluşması tehlikesi! Montaj esnasında büyük bir itinayla çalışınız, ürünü dikkatlice çalışınız ve mutlaka montaj talimatına uyunuz. Ürün sadece bu konuda uzman bir kişi tarafından monte edilmelidir.
RU	Опасность повреждения! При монтаже изделия будьте внимательны и соблюдайте инструкции по монтажу. Изделие разрешается устанавливать только квалифицированному персоналу.	
2	D	Das beigefügte Wandbefestigungsmaterial (Dübel und Schrauben) eignet sich nur für festes Mauerwerk (z.B. Beton- oder Ziegelwände). Für andere Wandaufbauten sind eventuell Spezialdübel und andere Schrauben notwendig. Ziehen Sie gegebenenfalls eine Fachkraft zurate.
	GB	The enclosed wall mounting materials (dowels and screws) are only suitable for solid masonry (e. g. concrete or brick walls). Special dowels and other screws may be necessary for other wall constructions. If necessary, please consult a qualified professional.
	FR	Le matériel de fixation murale fourni (chevilles et vis) convient uniquement à des murs solides (p. ex. murs en béton ou en briques). Pour les autres constructions de murs, il faut éventuellement des chevilles spéciales et d'autres vis. Faites-vous conseiller par un spécialiste.
	IT	I materiali di fissaggio allegati (tasselli e viti) sono adatti solo ai muri compatti (ad es. di calcestruzzo o mattoni). Per altri tipi di pareti è probabile che occorran tasselli speciali e altre tipologie di viti. Richiedere eventualmente il consiglio di un esperto.
	NL	Het bijgeleverde bevestigingsmateriaal (pluggen en schroeven) is geschikt voor vaste muren (bijv. betonnen of bakstenen muren). Voor andere muurconstructies zijn eventueel speciale pluggen en andere schroeven noodzakelijk. Consulteer eventueel een vakman.
	PL	Załączony zestaw montażowy do zamocowania artykułu do ściany (kołki, wkręty, haki itp.), przeznaczony jest wyłącznie do montażu artykułu na ścianach wykonanych z cegły lub betonu. Przy montażu artykułu na ścianie wykonanej z innych materiałów, należy zastosować odpowiednie do niej zamocowania. W razie wątpliwości prosimy zasięgnąć porady fachowca.

	CZ	Příložený materiál pro montáž na stěnu (hmoždinky a šrouby) je vhodný jen pro pevné zdivo (např. betonové nebo cihlové stěny). Pro jiné skladby stěn budou případně nutné speciální hmoždinky a jiné šrouby. Poradte se případně s odborníkem.
	SK	Priložený materiál pre upevnenie na stenu (hmoždinky a skrutky) je vhodný len pre pevné murivo (napr. betónové alebo tehlové steny). Pre iné steny sú potrebné príp. špeciálne hmoždinky a iné skrutky. V prípade potreby sa poradte s odborníkom.
	HU	A mellékelt fali rögzítőkészlet (tiplí és csavarok) csak tömött falazatban (pl. betonfalban, téglafalban) használható. Más faltípusokhoz speciális tiplire és csavarra lesz szükség. Szükség esetén kérje ki egy szakember véleményét.
	RO	Materialul furnizat pentru montajul de perete (dibluri și șuruburi) este adecvat numai pentru zidărie solidă (de exemplu pereți din beton sau din cărămidă). Pentru alte structuri de pereți, este posibil să fie necesare dibluri speciale, precum și alte șuruburi. Dacă este necesar, consultați un specialist.
	TR	Teslimat kapsamındaki duvar tipi sabitleme materyali (dübel ve vidalar) sadece beton ve tuğla duvarları gibi sağlam duvar yapıları için uygundur. Başka duvar yapıları için özel dübeller veya başka vidalar gerekli olabilir. Gerekirse bir uzmandan yardım alınız.
	RU	Входящий в комплект поставки материал для крепления на стене (дюбели и болты) предназначен только для прочных каменных стен (например, бетонных или кирпичных). Для других типов стен используйте по мере необходимости специальные дюбели и другие болты. По мере необходимости обратитесь за помощью к специалистам.
3	D	Verwenden Sie den Artikel nur in geschlossenen Räumen.
	GB	Only use the product in indoor spaces.
	FR	Utilisez l'article uniquement dans des locaux fermés.
	IT	Utilizzare l'articolo sono in locali al chiuso.
	NL	Gebruik het artikel alleen in gesloten ruimten.
	PL	Produkt należy użytkować wyłącznie w pomieszczeniach zamkniętych.
	CZ	Používejte výrobek jen v uzavřených prostorech.
	SK	Používajte výrobok len v uzavretých miestnostiach.
	HU	Az árut kizárólag fedett helyiségben használja.
	RO	Utilizați produsul numai în spații închise.
	TR	Ürünü sadece kapalı mekanlarda kullanınız.
	RU	Используйте изделие только в закрытых помещениях.
4	D	Schützen Sie Ihre Möbel generell vor Wasser (z.B. beim Wischen oder Blumen gießen). Die Feuchtigkeit kann in das Möbelstück eindringen und es beschädigen
	GB	In general, keep water away from your furniture (e. g. when mopping or watering plants). The moisture may penetrate the furniture and damage it.
	FR	Protégez vos meubles contre l'eau (p. ex. lorsque vous lavez ou arrosez des fleurs). L'humidité peut pénétrer dans le meuble et l'endommager.
	IT	Proteggere in ogni caso i mobili dall'acqua (ad es. pulendo con panni umidi o innaffiando i fiori). L'umidità potrebbe penetrare nel mobile e danneggiarlo.
	NL	Bescherm uw meubelen doorgaans tegen water (bijv. bij het dweilen of als u de bloemen water geeft). De vochtigheid kan in het meubelstuk dringen en het beschadigen.
	PL	Należy generalnie unikać kontaktu mebla z wodą (np. podczas czyszczenia lub podlewania kwiatów). Wilgoć może wnikać w mebel i uszkodzić go.
	CZ	Chraňte váš nábytek před vodou (např. při utírání prachu nebo zalévání květin). Vlhkost může do nábytku proniknout a poškodit ho.
	SK	Chráňte váš nábytok celkovo pred vodou (napr. pri utieraní alebo polievaní kvetín). Vlhkosť môže vniknúť do nábytku a poškodiť ho.
	HU	Védje a bútort a víz ellen (pl. a letörlések során, ill. a növények öntözésekor). A nedvesség behatolhat a bútortba és azt tönkre teheti.
	RO	Protejați întotdeauna mobilierul contra apei (de exemplu la ștergere sau la udarea florilor). Mobilierul poate fi astfel expus umidității și se poate deteriora.
	TR	Genelde mobilyalarınızı sudan koruyunuz (örneğin, yerleri paspaslarken veya çiçekleri sularken). Nem, mobilya parçasına nüfuz edebilir ve zarar verebilir.
	RU	Предохраняйте мебель от попадания воды (например, при вытирании или поливке цветов). Не допускайте попадания влаги на мебель, чтобы предотвратить ее повреждение.

0
10
20
30
40
50
60
70
80
90
100
110
120
130
140
150
160
170
180
190
200

Service • Assistenza • Dienstverlening • Serwis
Servis • Szerviz • Сервисная служба

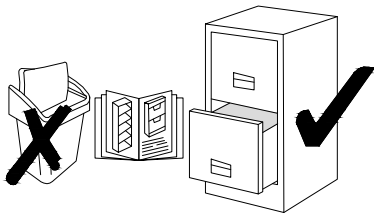
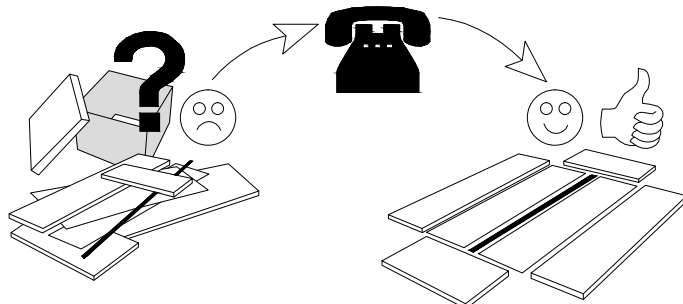
Name • Nom • Nome • Naam Nazwa • Jméno • Názov • Név Denumire • Isim • Название	Aalborg
Nr. • No. • N° • Номер • Č. • Sz	9841 1021
Typ • Type • Тір • Тип	
	
	

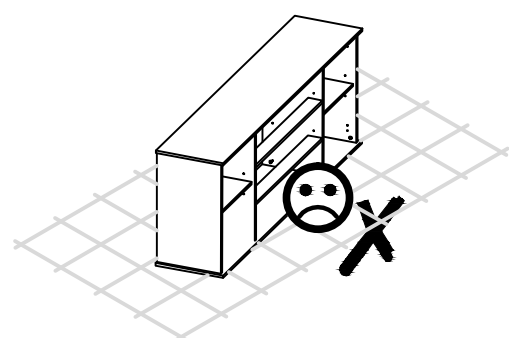
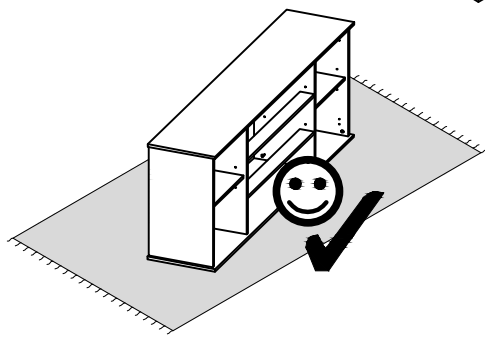
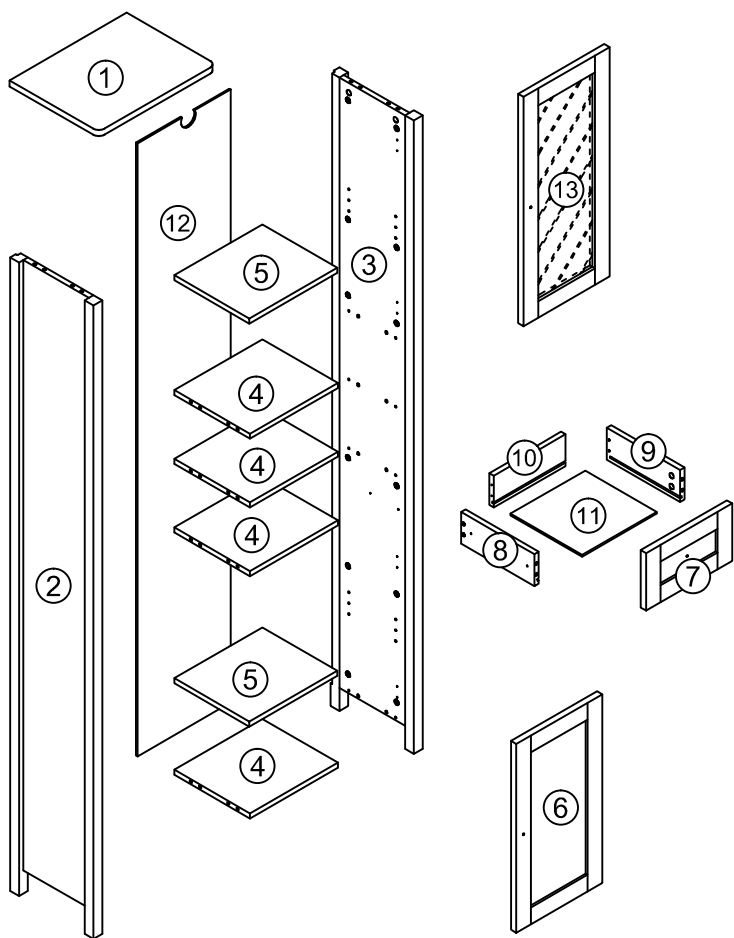



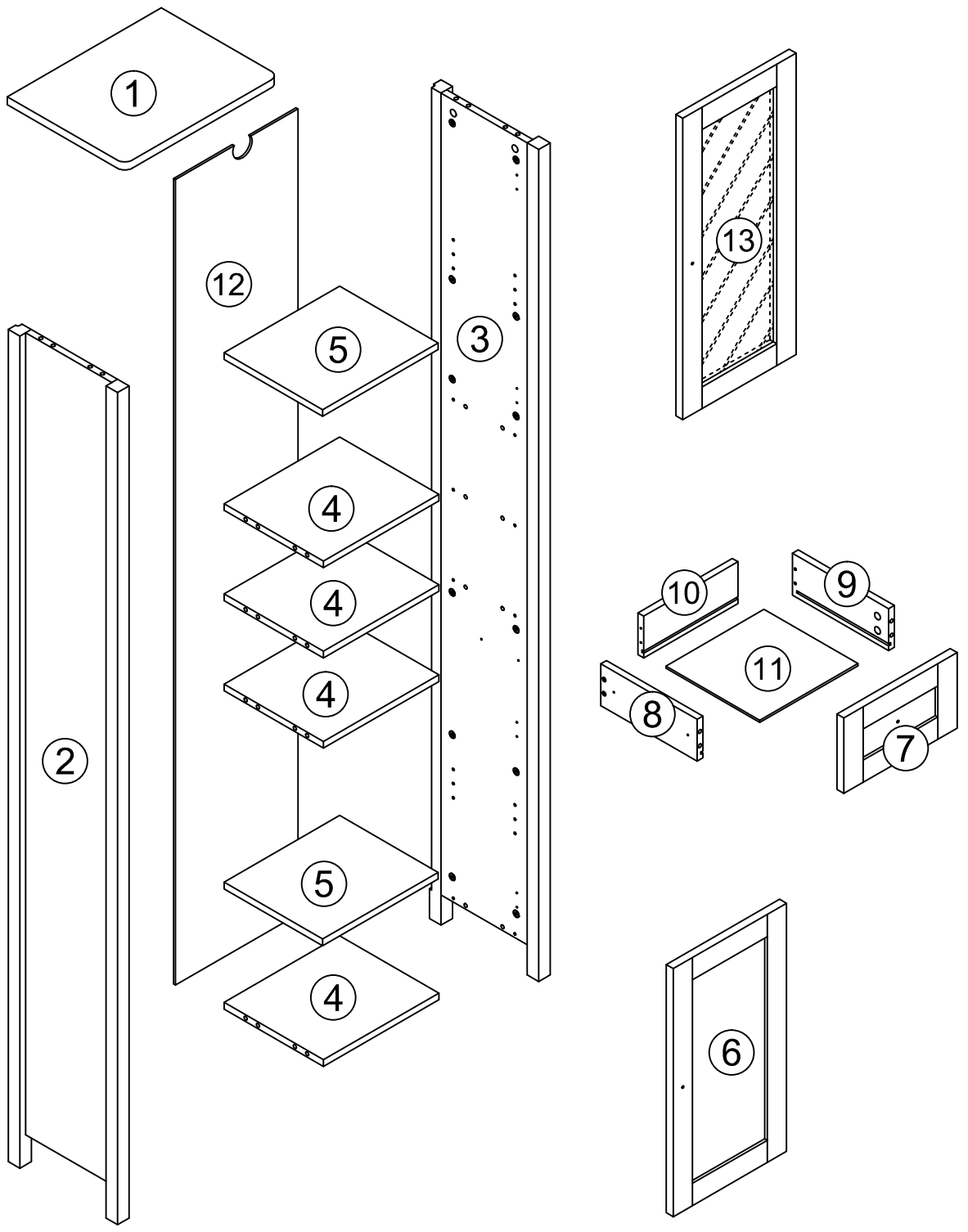













0
10
20
30
40
50
60
70
80
90
100
110
120
130
140
150
160
170
180
190
200



0
10
20
30
40
50
60
70
80
90
100
110
120
130
140
150
160
170
180
190
200

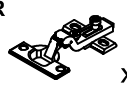



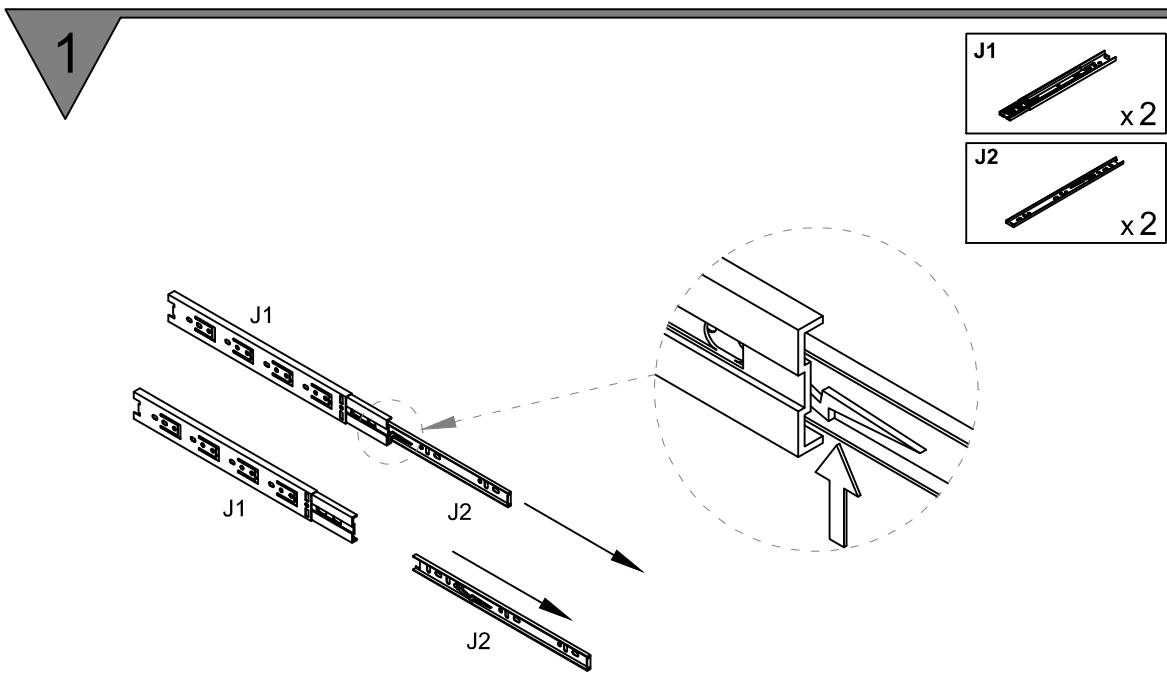

N	Size/MaB(mm)	Qty	√	N	Size/MaB(mm)	Qty	√
1	400x305x18	1		7	294x170x18	1	
2	1872x284x30	1		8	250x94x15	1	
3	1872x284x30	1		9	250x94x15	1	
4	300x258x15	4		10	245x93x15	1	
5	299x256x15	2		11	255x244x5	1	
6	558x294x18	1		12	1812x318x5	1	
				13	679x294x18	1	

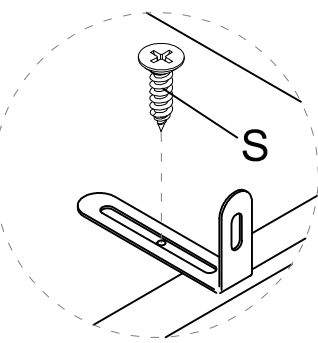
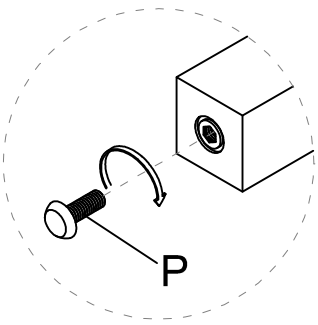
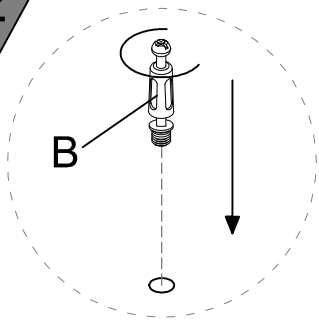
A  15 x 12 x 24	B  7 x 35 x 24	C  8 x 30 x 20	D  3.5 x 14 x 10	E  x 3
F  4 x 10 x 1	G  4 x 22 x 2	H  x 8	J  L250 x 1	K  4 x 40 x 5
L  x 1	M  20 x 0.5 x 48	N  x 1	P  6 x 20 x 4	Q  x 34
R  x 4	S  4x16 x 17			



2



B	7 x 35
	x 20
D	3.5 x 14
	x 6
J1	
	x 2
N	
	x 1
P	6 x 20
	x 4
S	4 x 16
	x 1

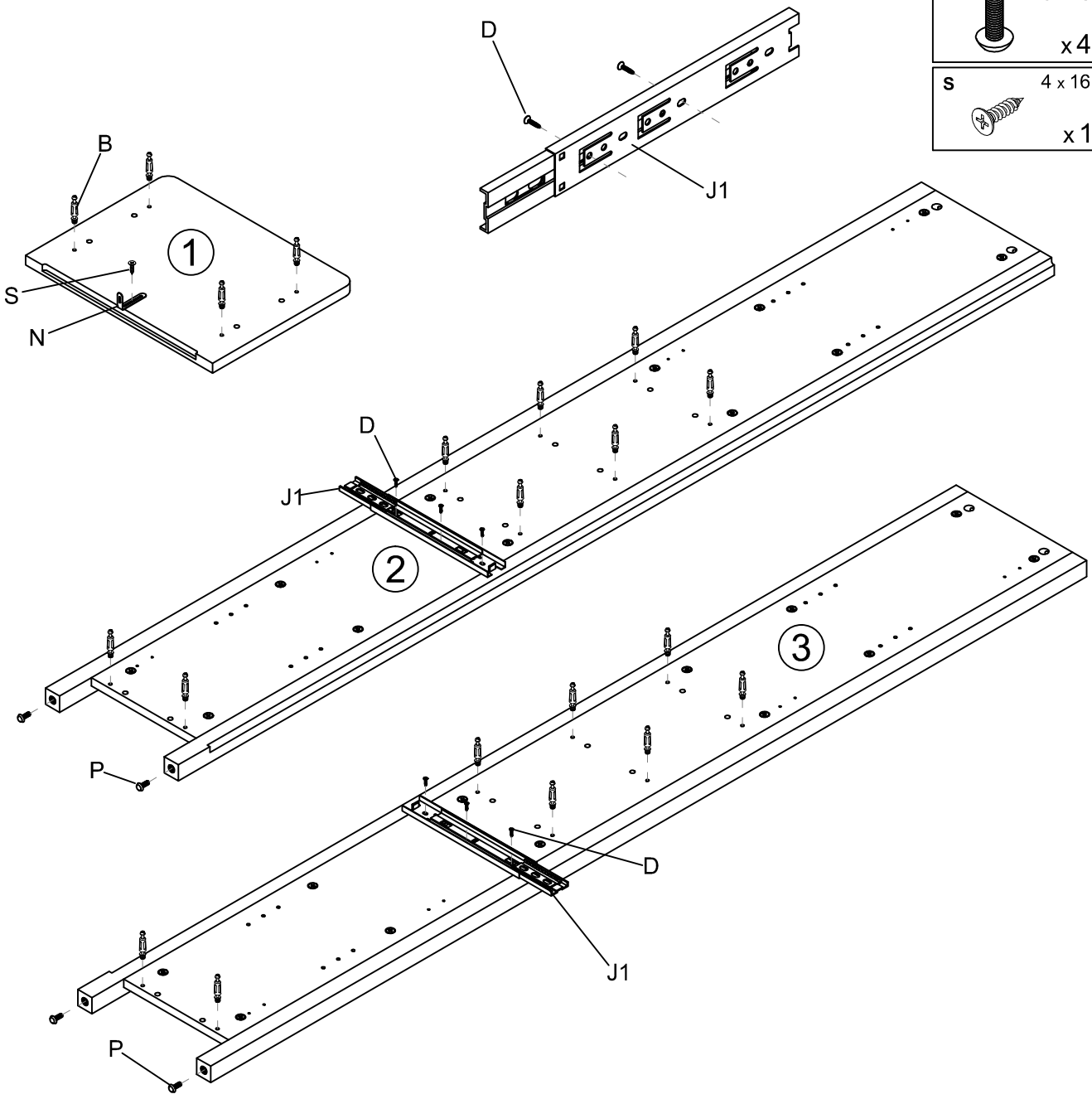

3

A 15 x 12
x 24

C 8 x 30
x 20

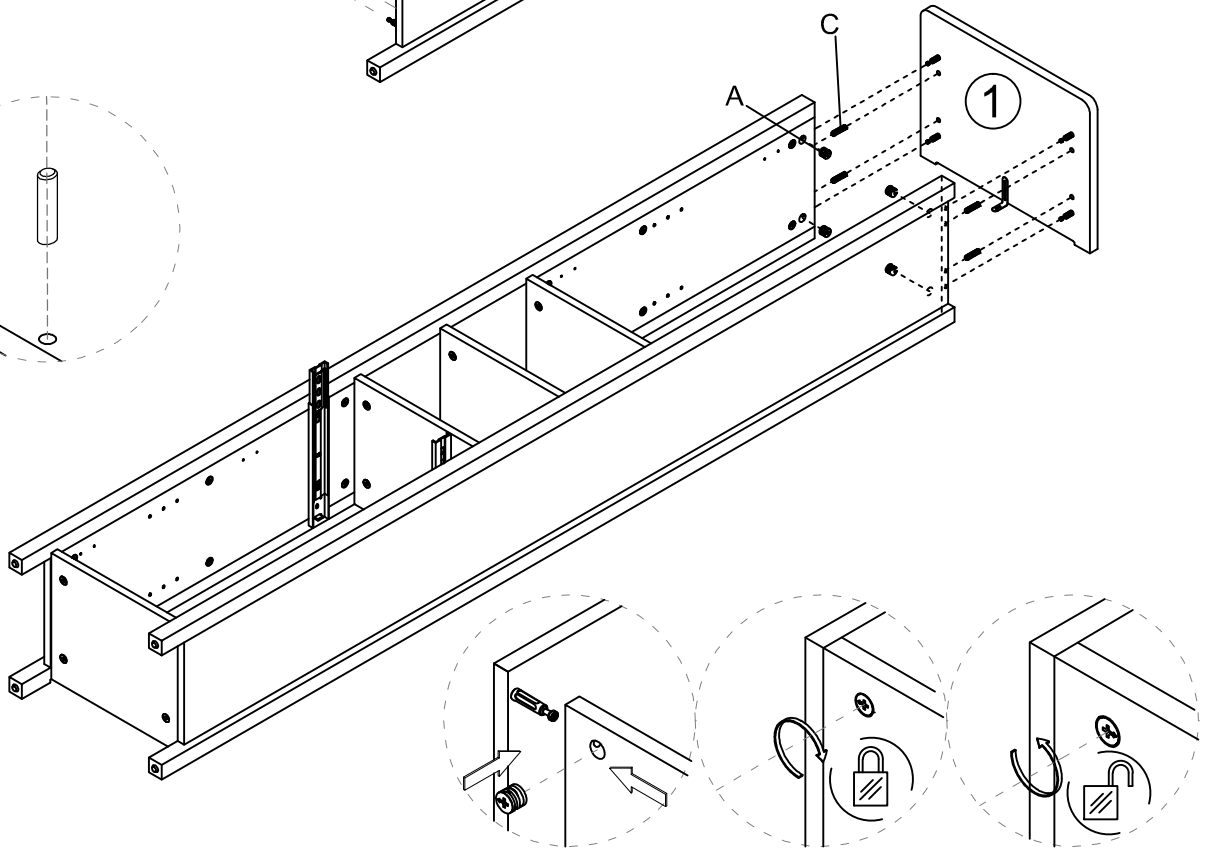
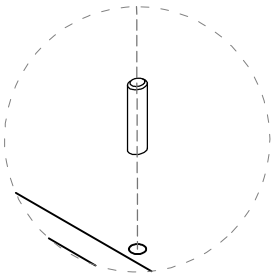
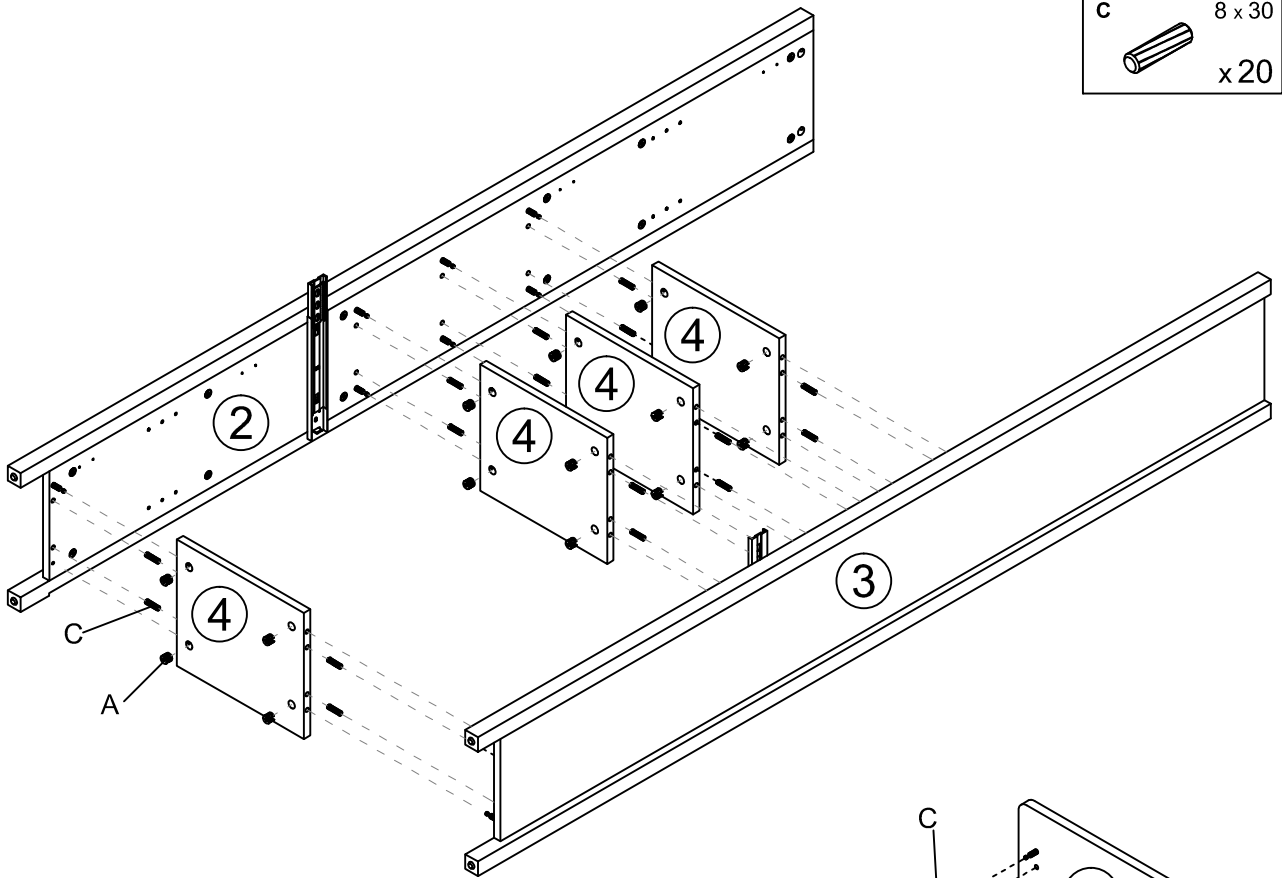

4

K 4 x 40
x 1

L
x 1

Q
x 34

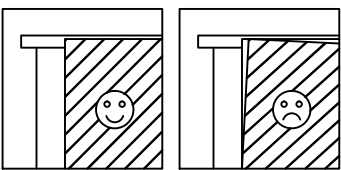
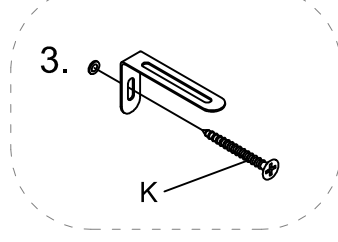
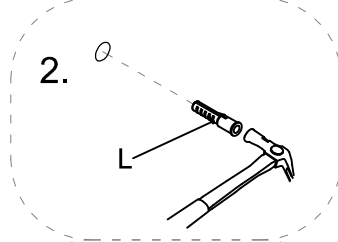
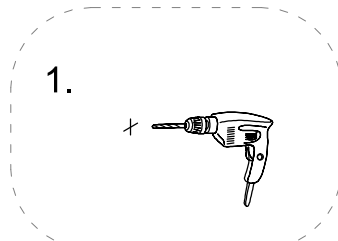
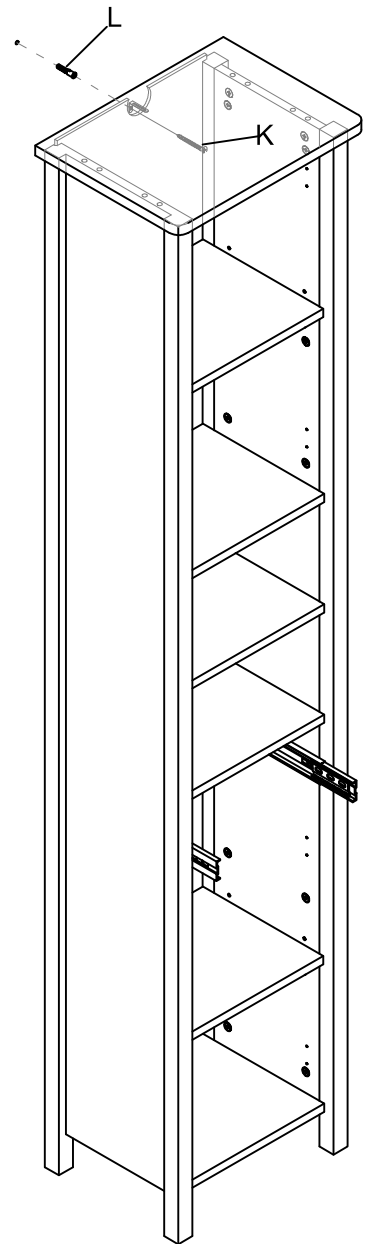
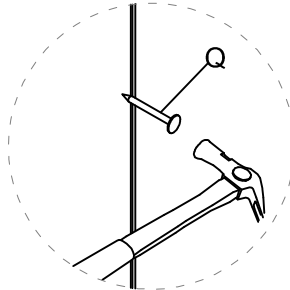
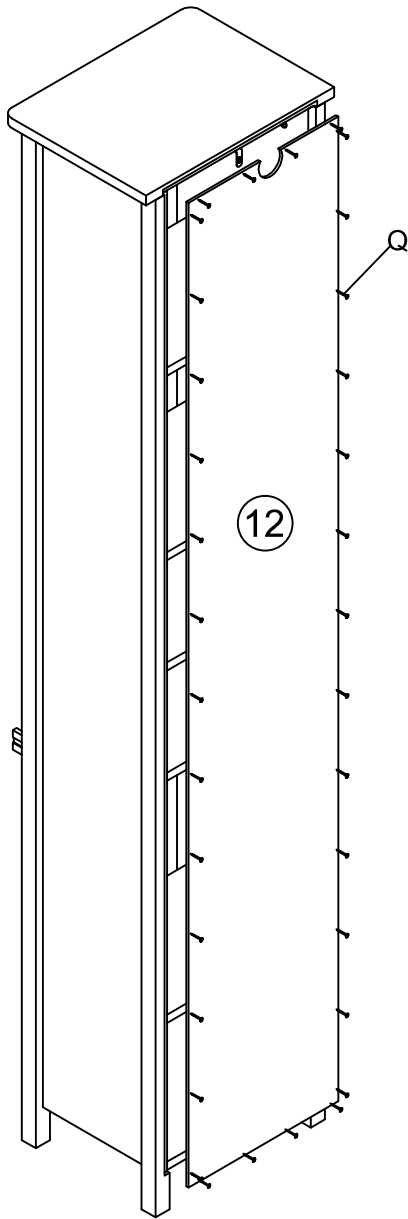

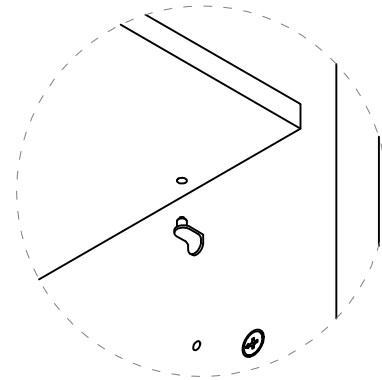
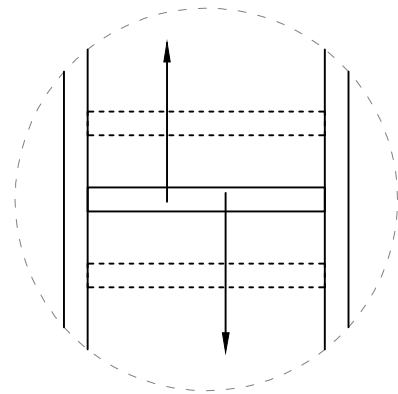
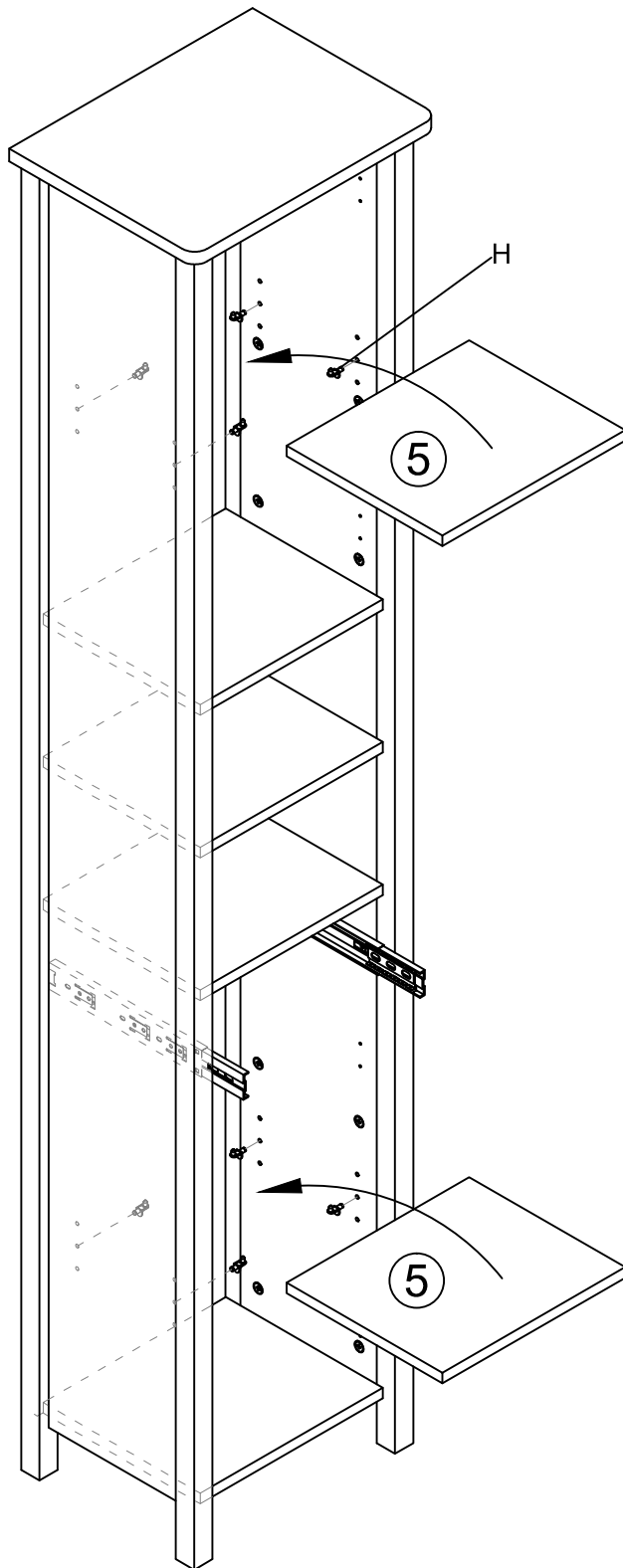

5

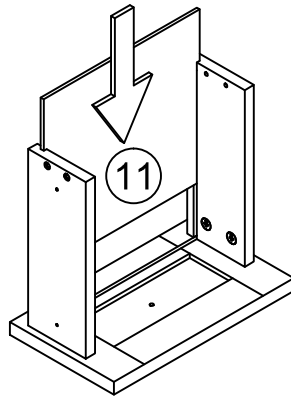
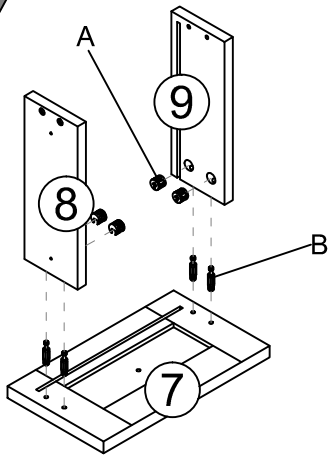

6





A 15 x 12
 x 4

B 7 x 35
 x 4

D 3.5 x 14
 x 4

E
 x 1

F 4 x 10
 x 1

J2 L250
 x 2

K 4 x 40
 x 4

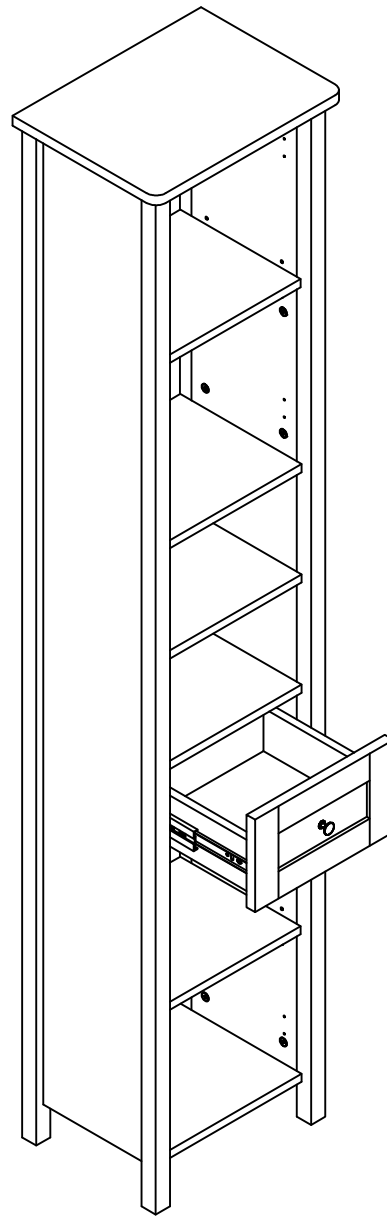
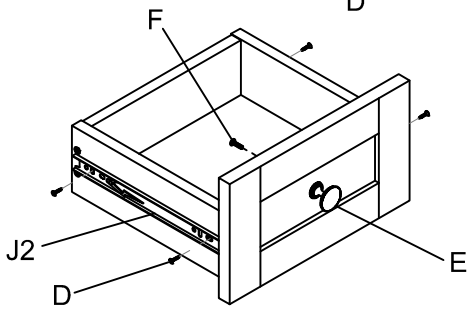
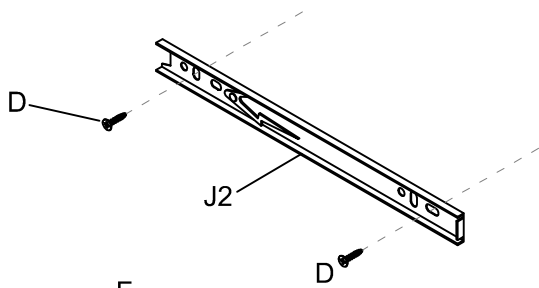
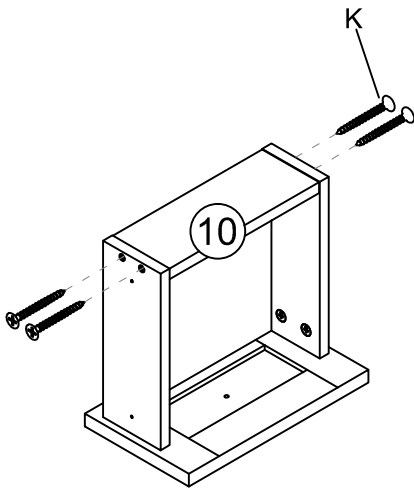

7

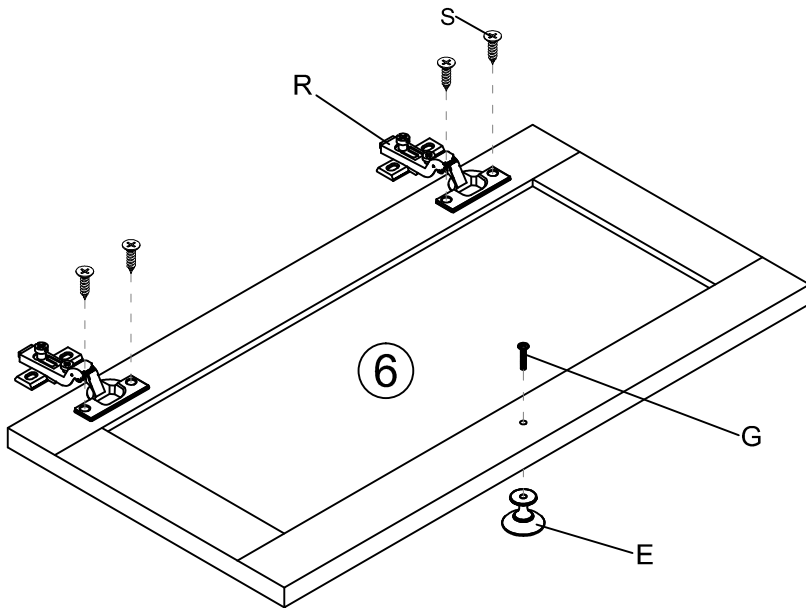
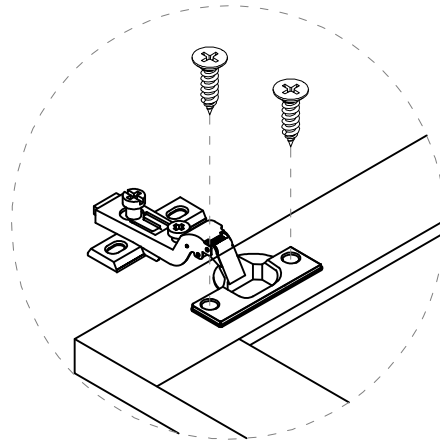
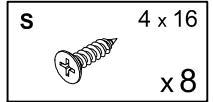
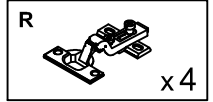
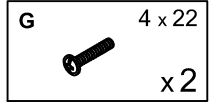
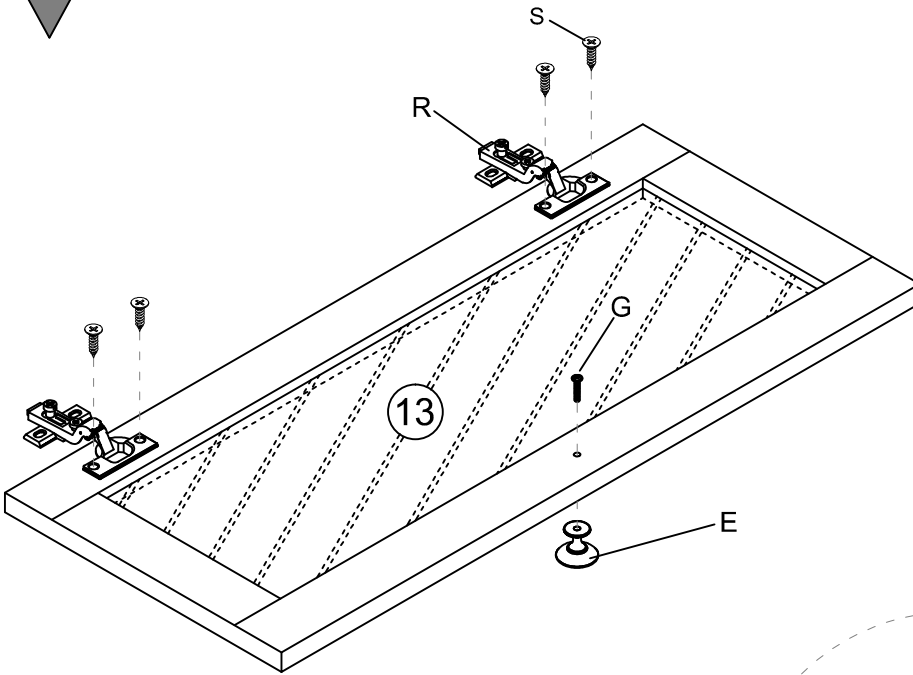

8

L

R

S 4 x 16
x 8

M 20 x 0.5
x 48

