

TURIN ZB 210

84/005/.../...



„MEBLE-OKMED” DEMKO - SPÓŁKA JAWNA
ul. Kolejowa 13, 14-500 Braniewo, POLSKA
(+48) 55 243 27 26

SERIA: .../...

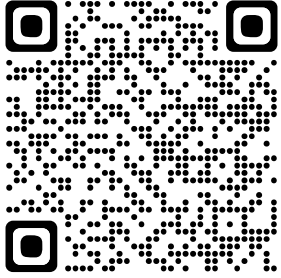
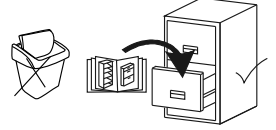

TURIN ZB 210
ZP:/..

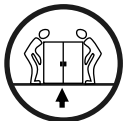
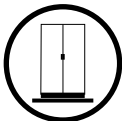
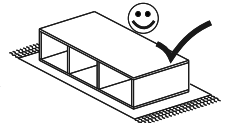
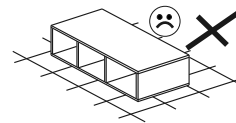
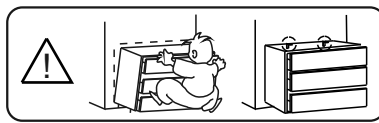
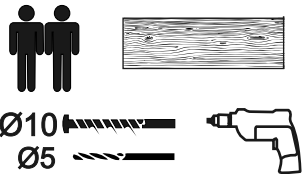
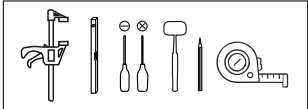
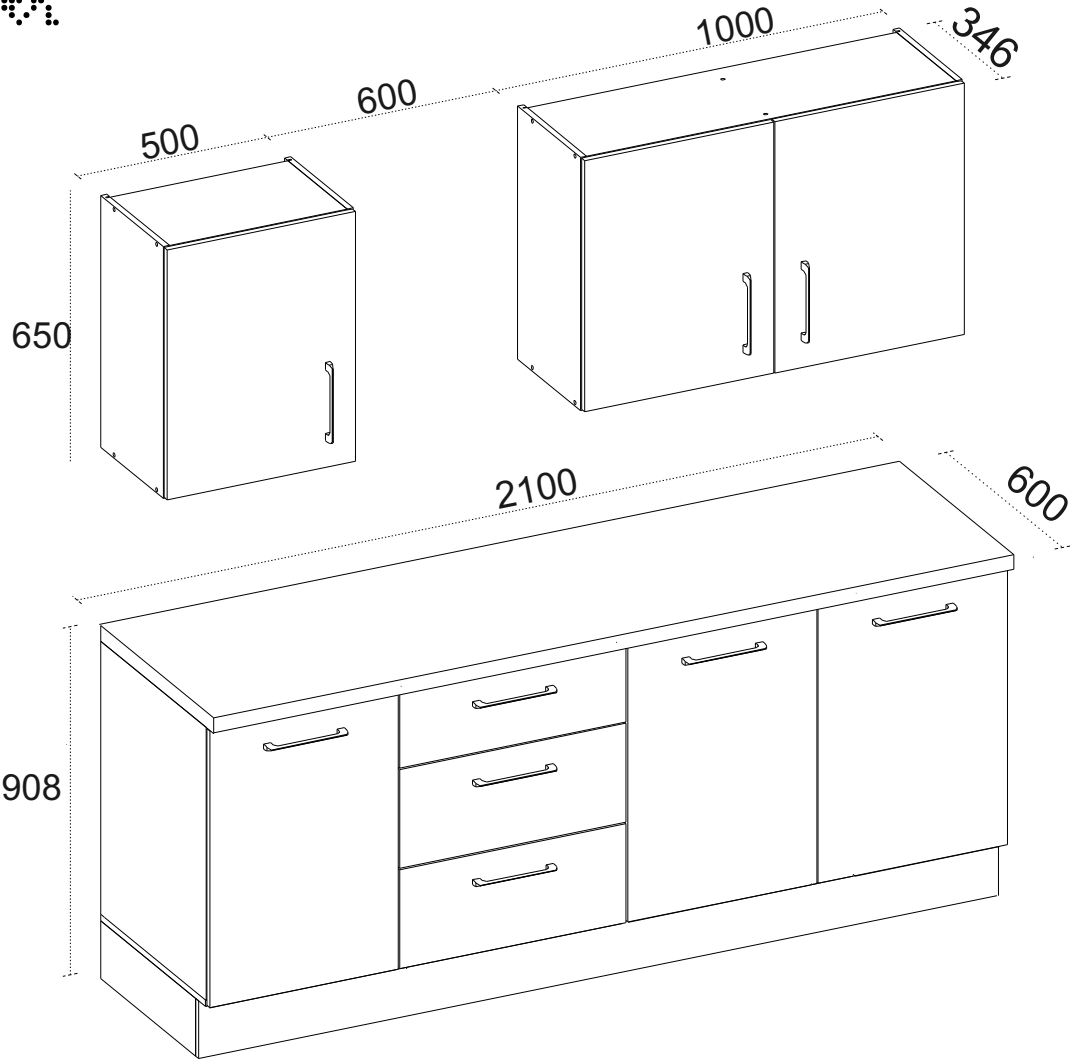

COLLI 1/6

3-6

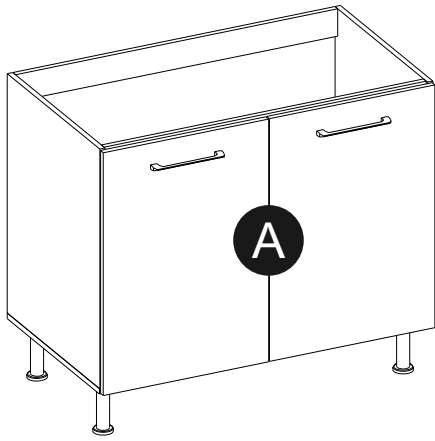

COLLI 2/6

7-19

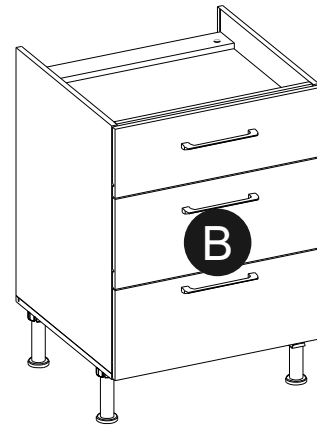

COLLI 3/6

20-25

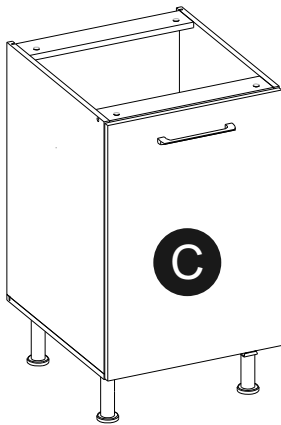

COLLI 4/6

26-31

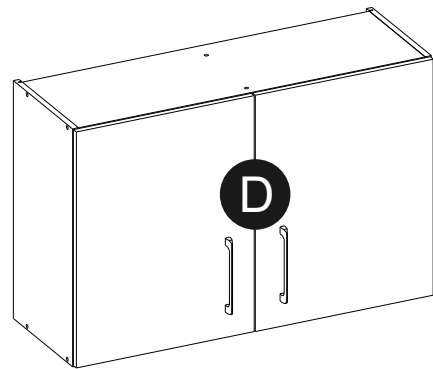

COLLI 5/6

32-37

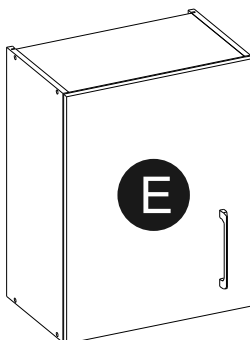

COLLI 6/6

38-35

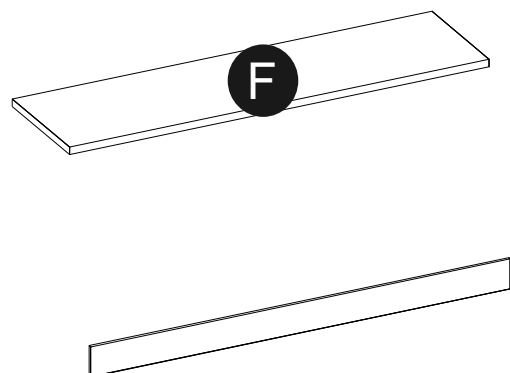

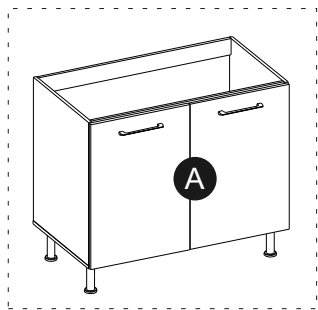

N	L [mm]	W [mm]	T [mm]	Q	COLLI
1	713	496	16	2	COLLI_1/6
2	704	555	16	1	COLLI_1/6
3	704	555	16	1	COLLI_1/6
4	1000	555	16	1	COLLI_1/6
5	967	80	16	1	COLLI_1/6
6	967	80	16	1	COLLI_1/6

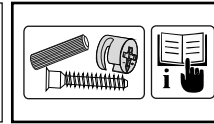
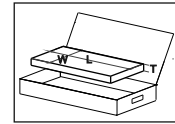

COLLI_1/6

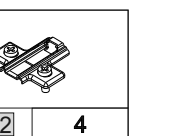
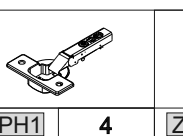
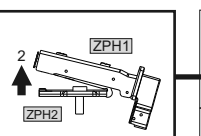
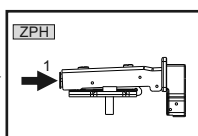
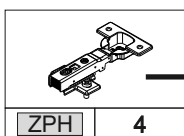
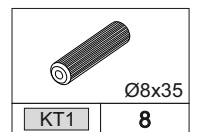
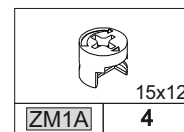
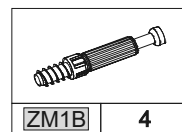
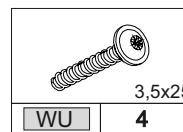
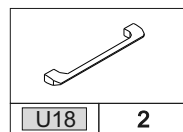
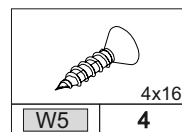
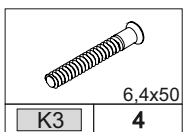
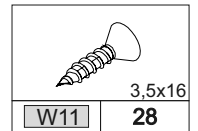
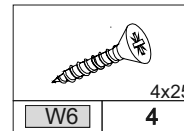
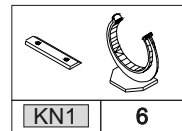
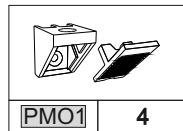
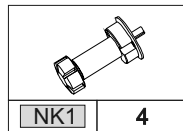
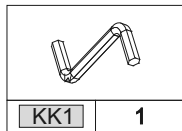
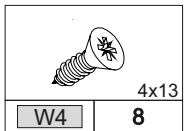
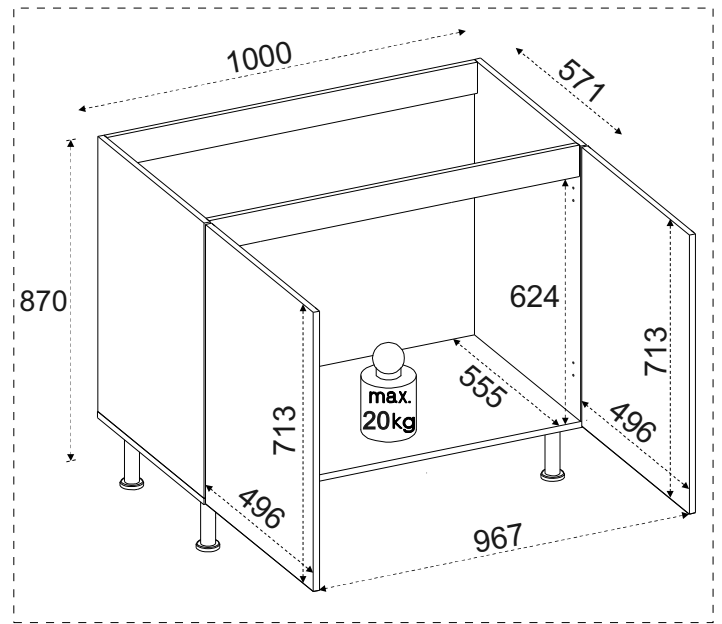
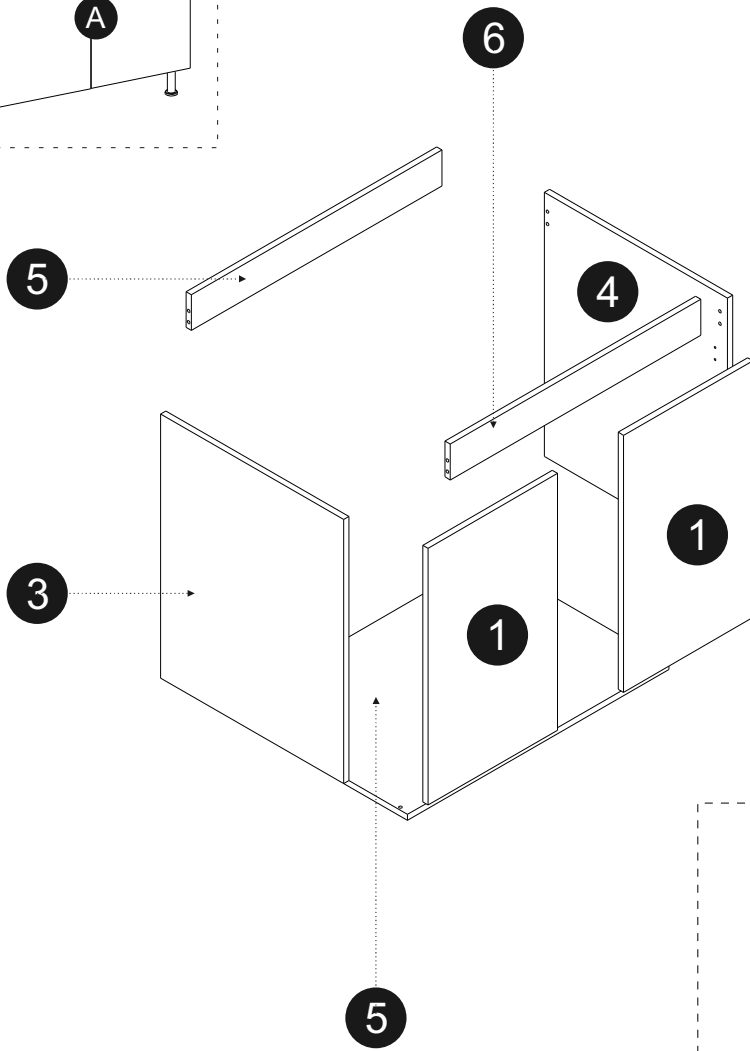

01

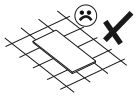

Ø8x35



KT1

8

ZPH2

4



15x12

ZM1A

4



ZM1B

4

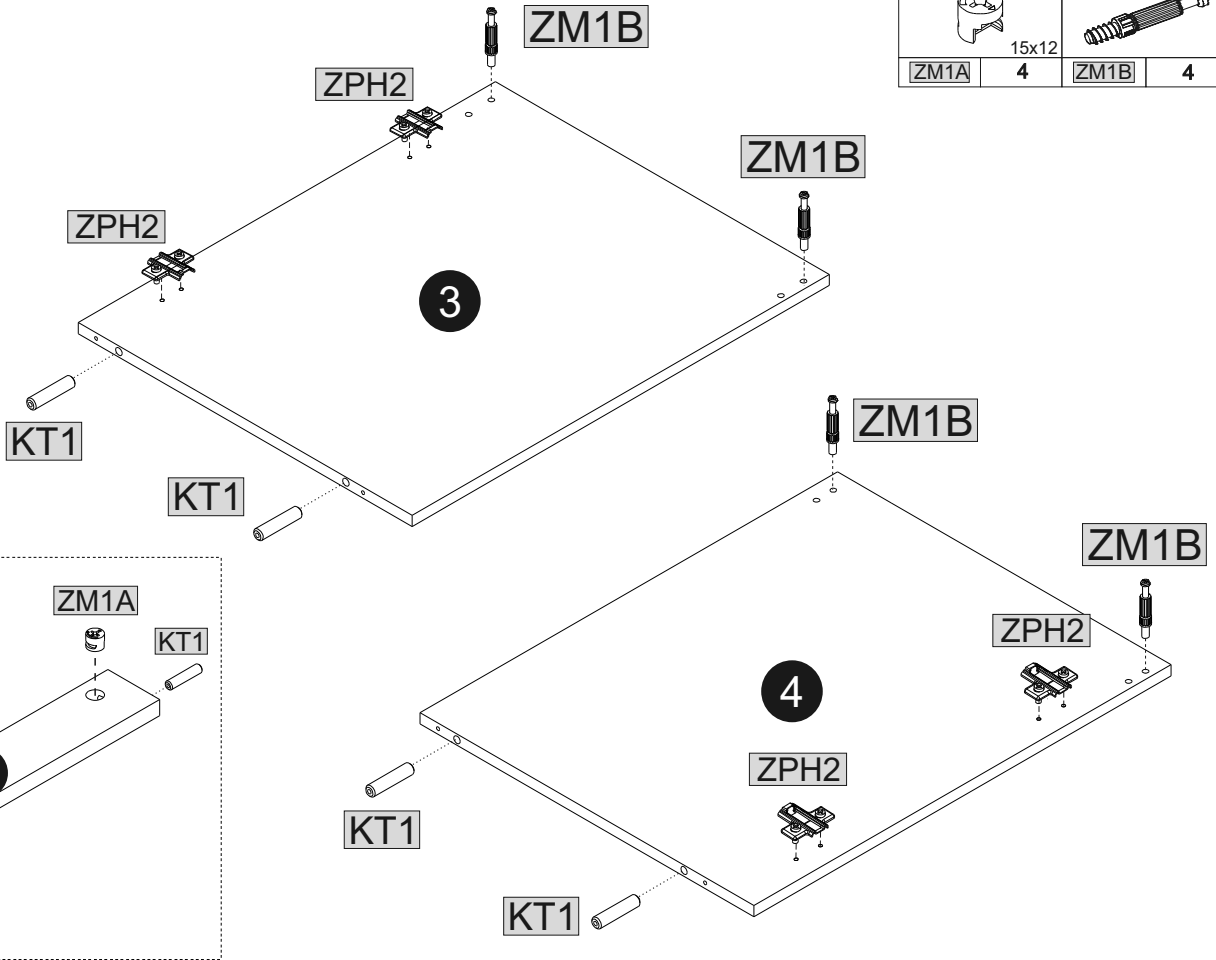
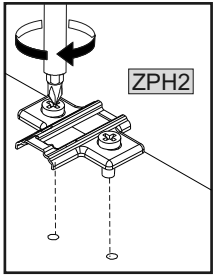

2X

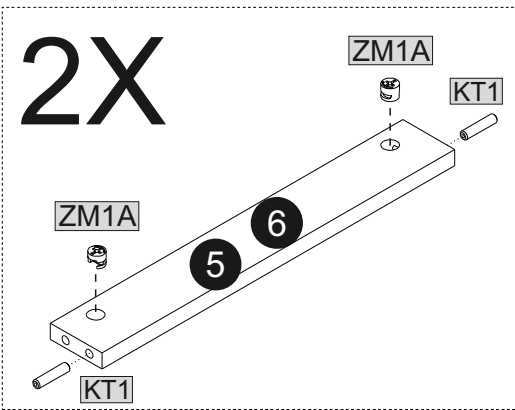

02

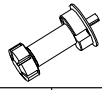
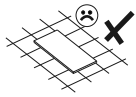
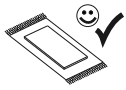

NK1

4

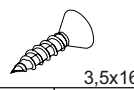

3,5x16

W11

16

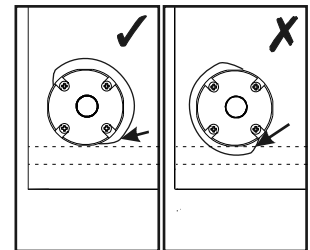
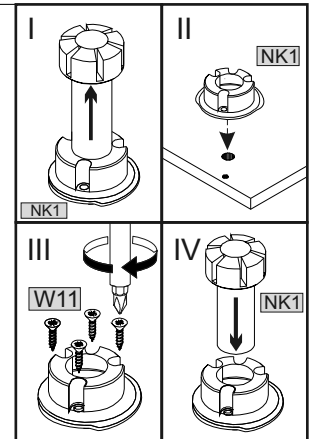
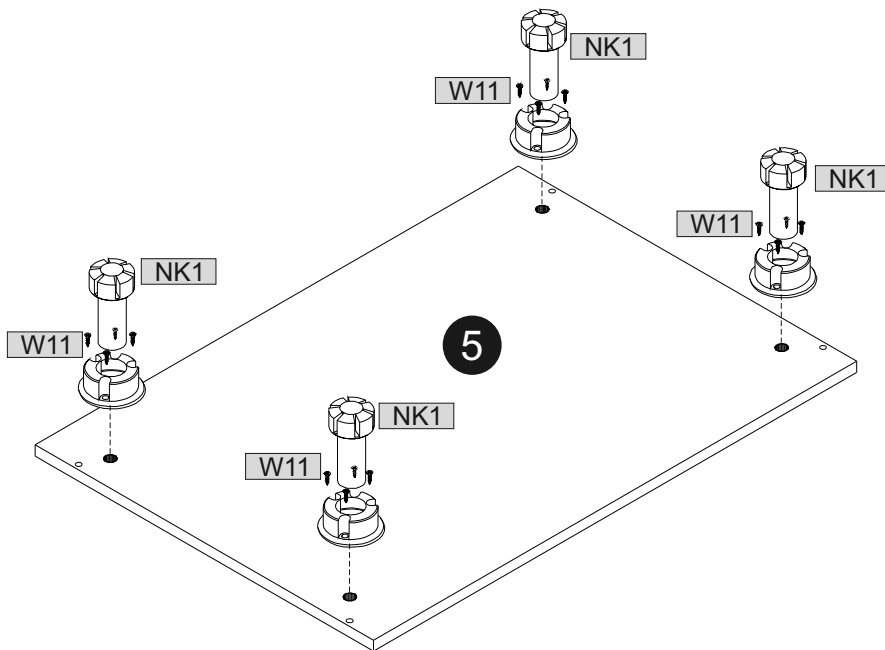
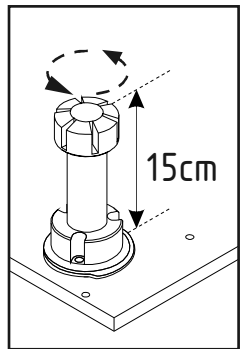

03

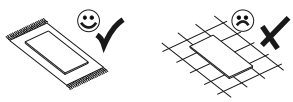

6,4x50

K3	4
----	---



KK1	1
-----	---

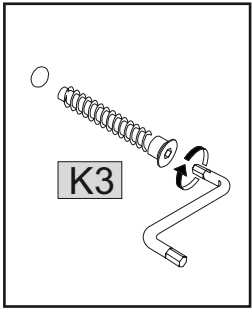
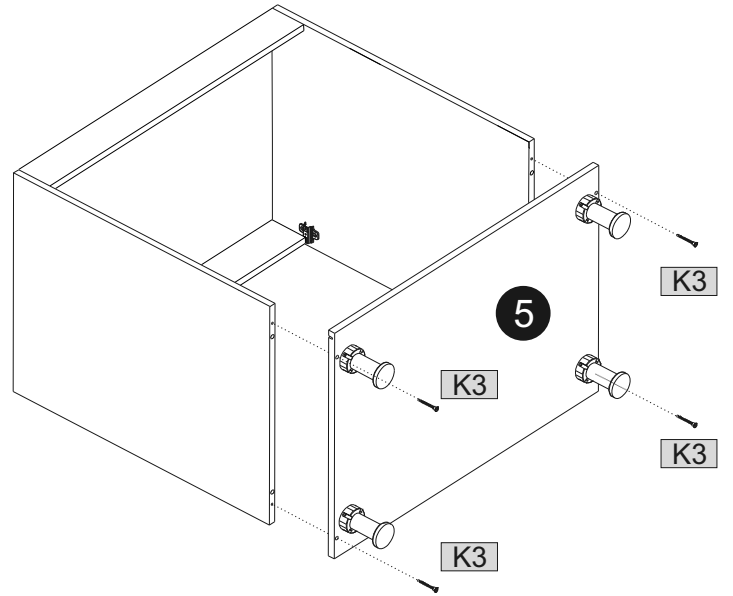
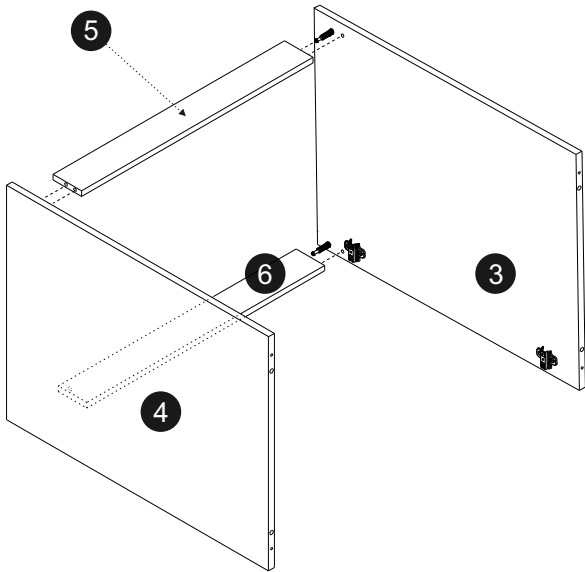

K3

04

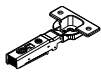





ZPH1	4
------	---

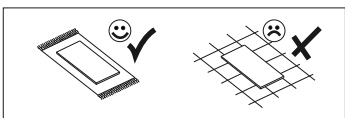
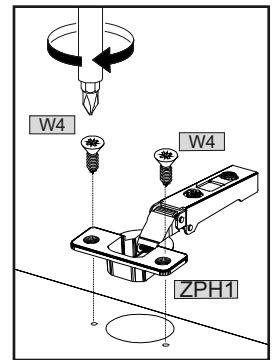
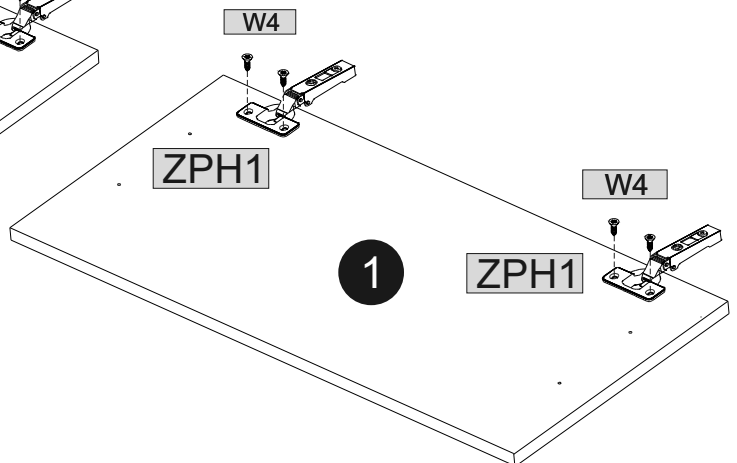
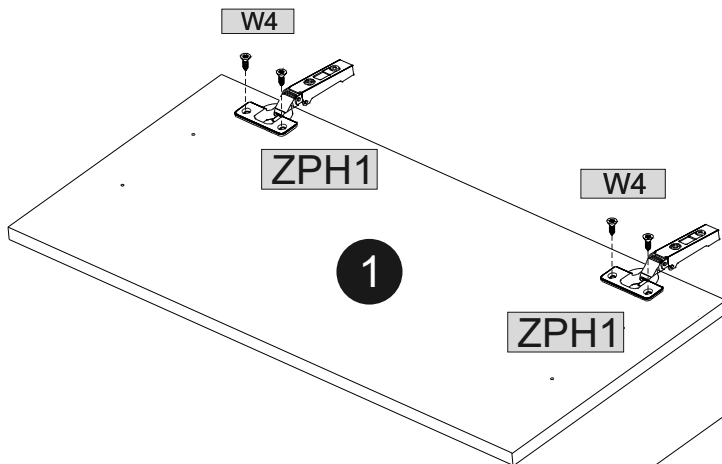

4x13

W4	8
----	---



	4x16						3.5x25
W5	4	PMO1	4	U18	2	WU	4

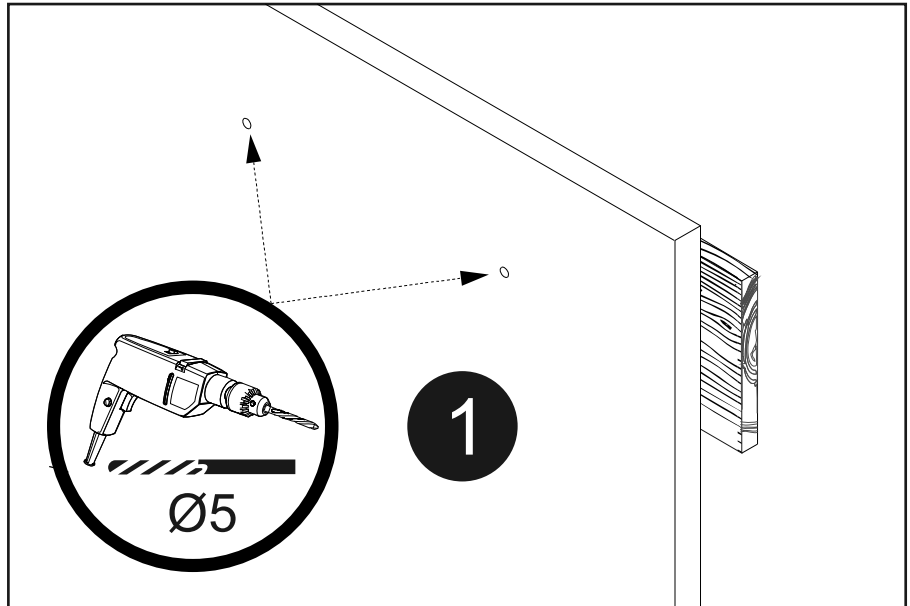
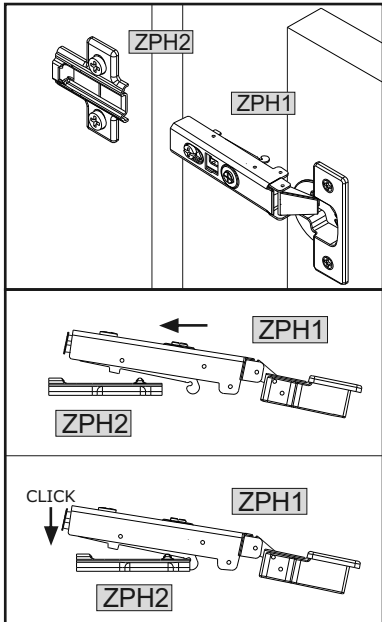
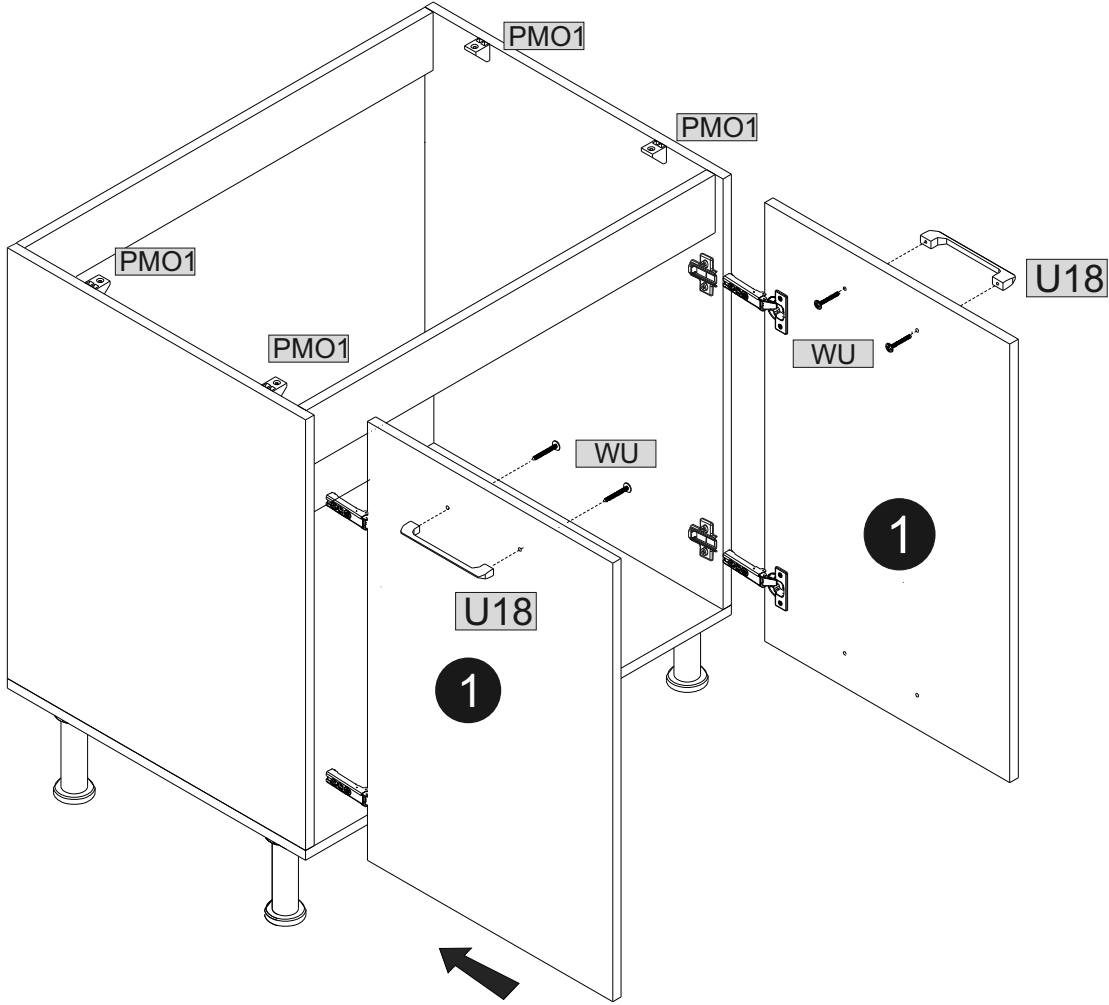
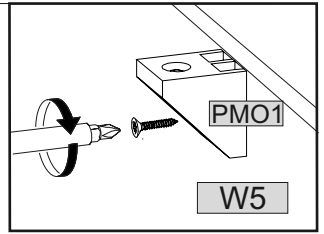

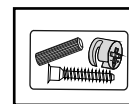
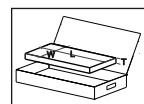
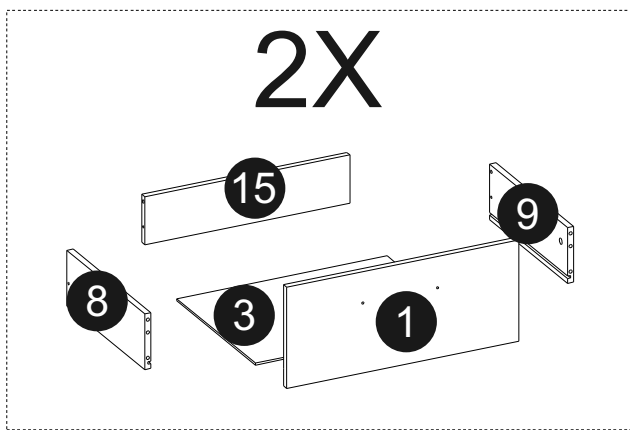
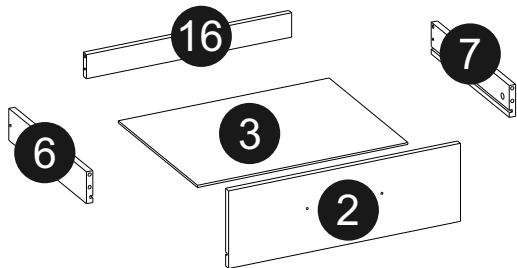
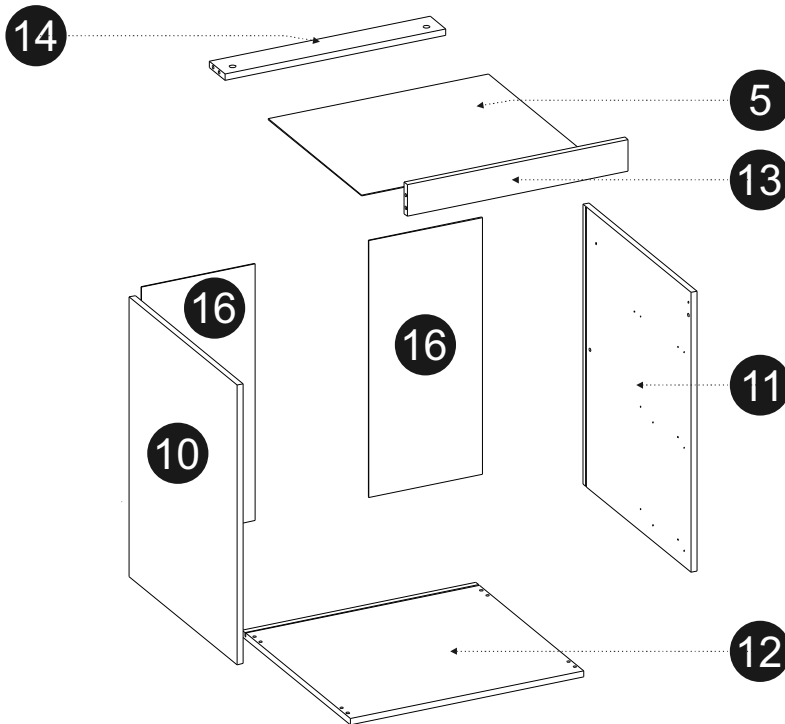
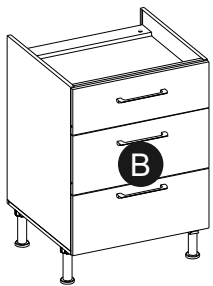

COLLI_2/8

N	L [mm]	W [mm]	T [mm]	Q	COLLI
1	255	596	16	2	COLLI_2/8
2	196	596	16	1	COLLI_2/8
3	541	405	5	3	COLLI_2/8
4	646	292	3	2	COLLI_2/8
5	565	480	2	1	COLLI_2/8
6	400	80	16	1	COLLI_2/8
7	400	80	16	1	COLLI_2/8
8	400	140	16	2	COLLI_2/8
9	400	140	16	2	COLLI_2/8
10	704	555	16	1	COLLI_2/8
11	704	555	16	1	COLLI_2/8
12	600	555	16	1	COLLI_2/8
13	567	80	16	1	COLLI_2/8
14	567	80	16	1	COLLI_2/8
15	527	121	16	2	COLLI_2/8
16	527	61	16	1	COLLI_2/8

U18 3	WU 6	W5 4	KN1 2
W2 6	LI 1	WDS3 3	PMO1 4
KK1 1	S1 12	W7 4	KT1 24
W1 38	NK1 4	ZS1 6	ZM1A 10
W11 47	KM1 6	ZM1B 10	ZM1 6
PQFR 3	PQFL 3	K3 4	

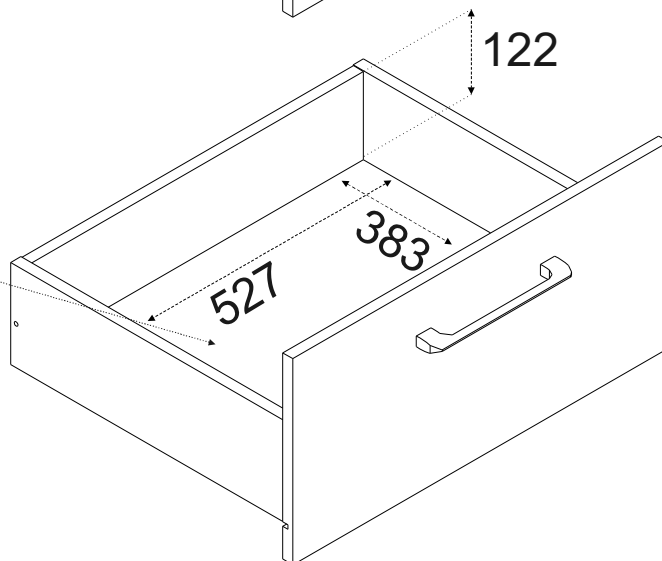
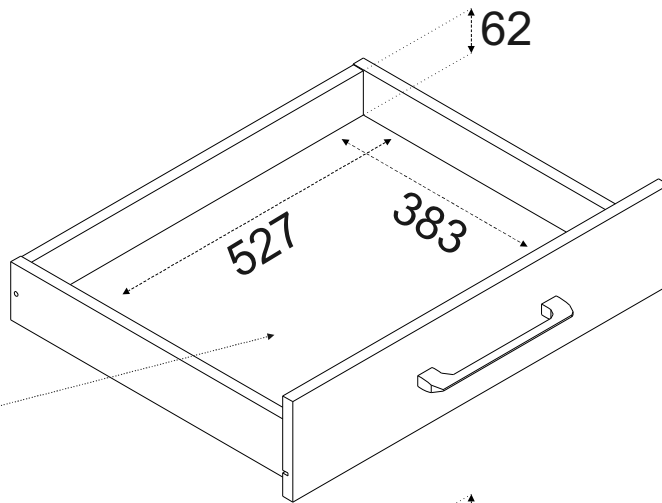
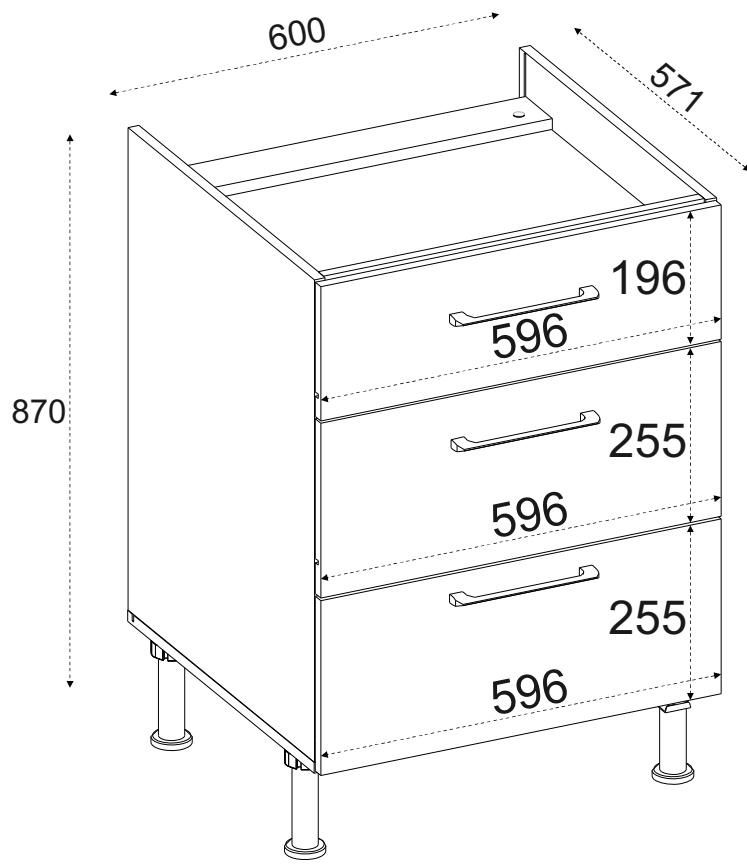

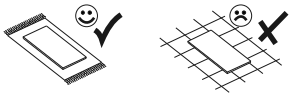

	L-400		L-400
PQFL	3	PQFR	3
	3,5x16		4
W11	24	ZM1B	4
KT1	4		

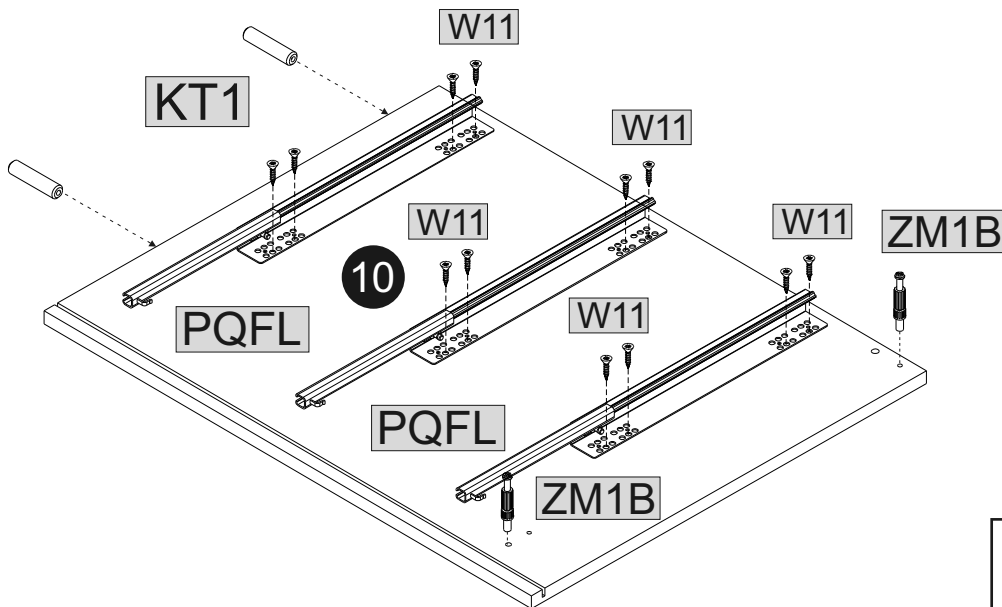
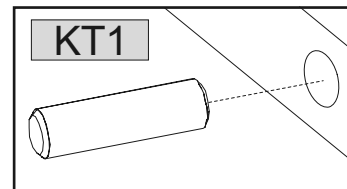
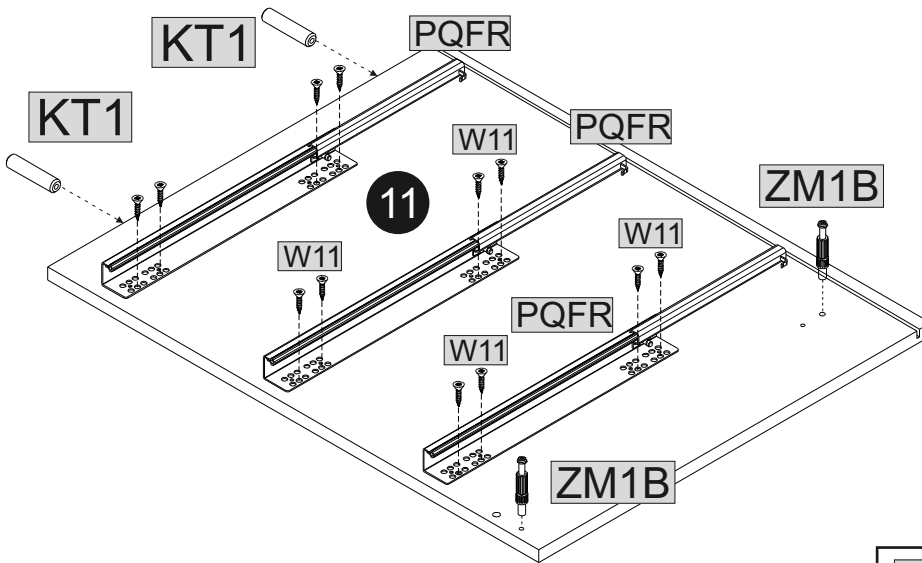

PQ3 & PQ4

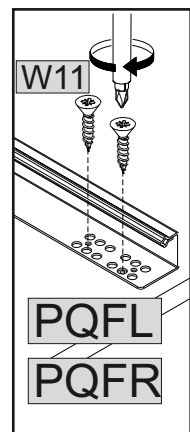
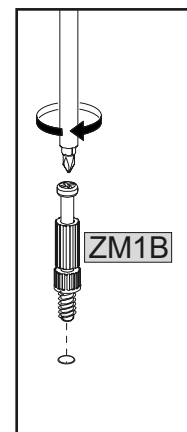
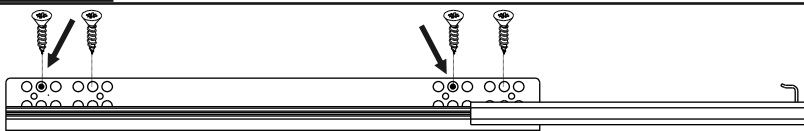

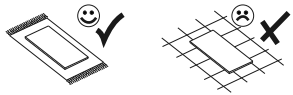

Ø8x35



15x12

KT1

4

ZM1A

4

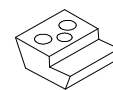

ZS1

3



3x20

W2

3

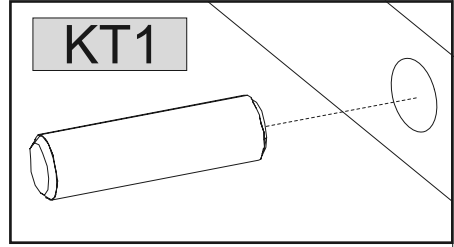
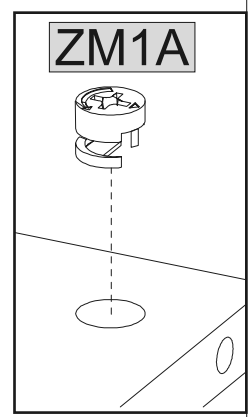
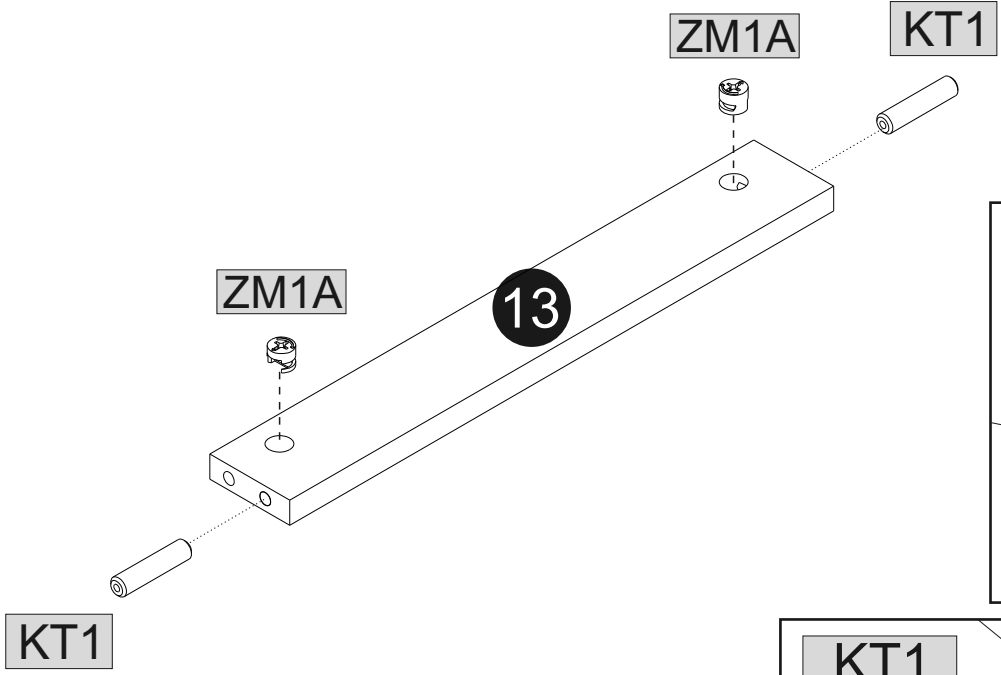
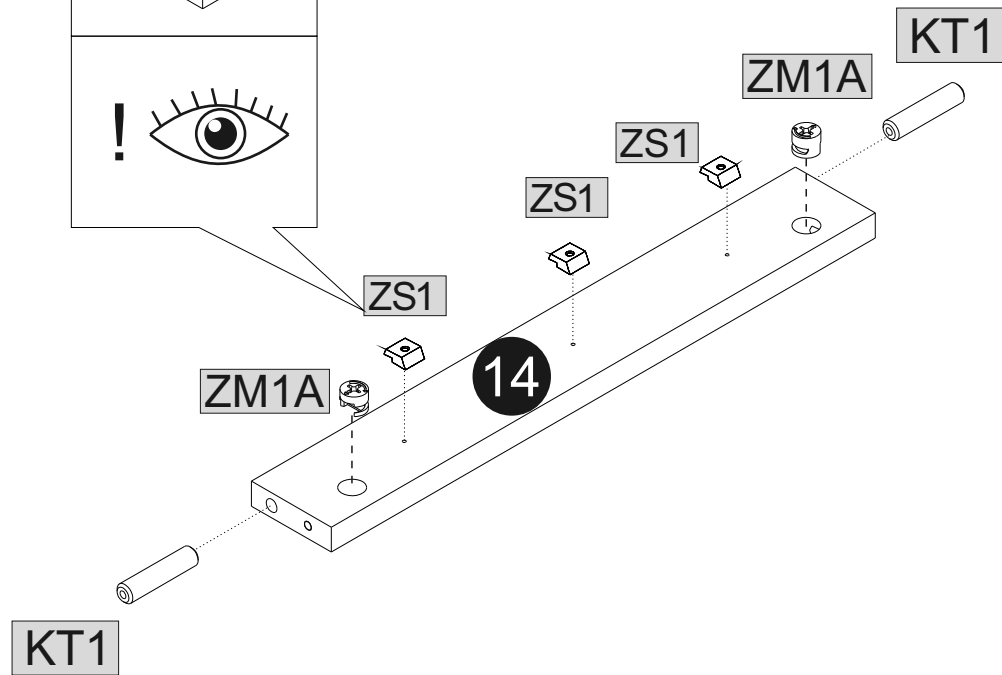
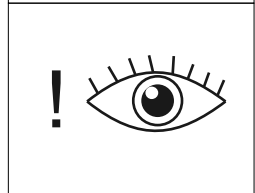
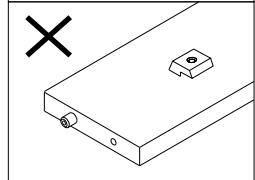
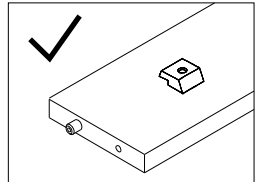

03



3,5x16

NK1

4

W11

16

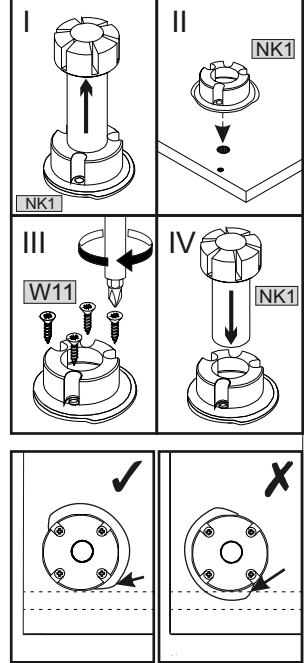
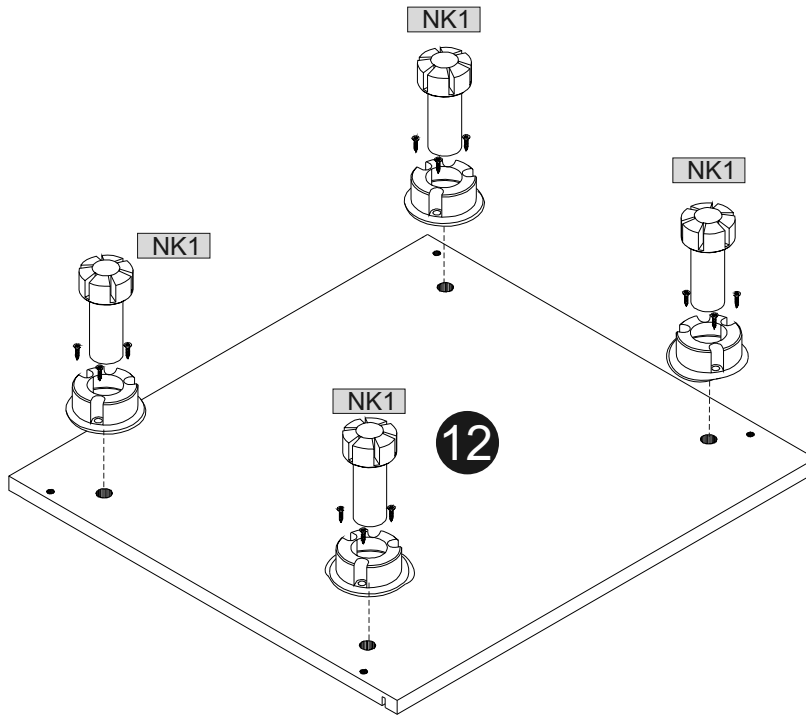
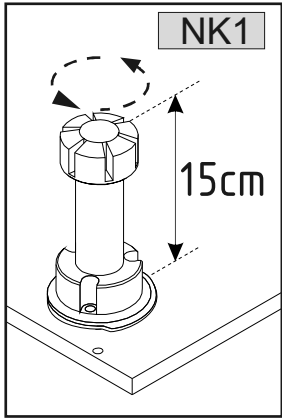

04

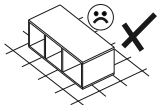
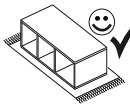

KK1

1

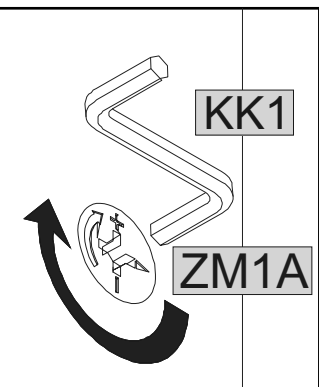
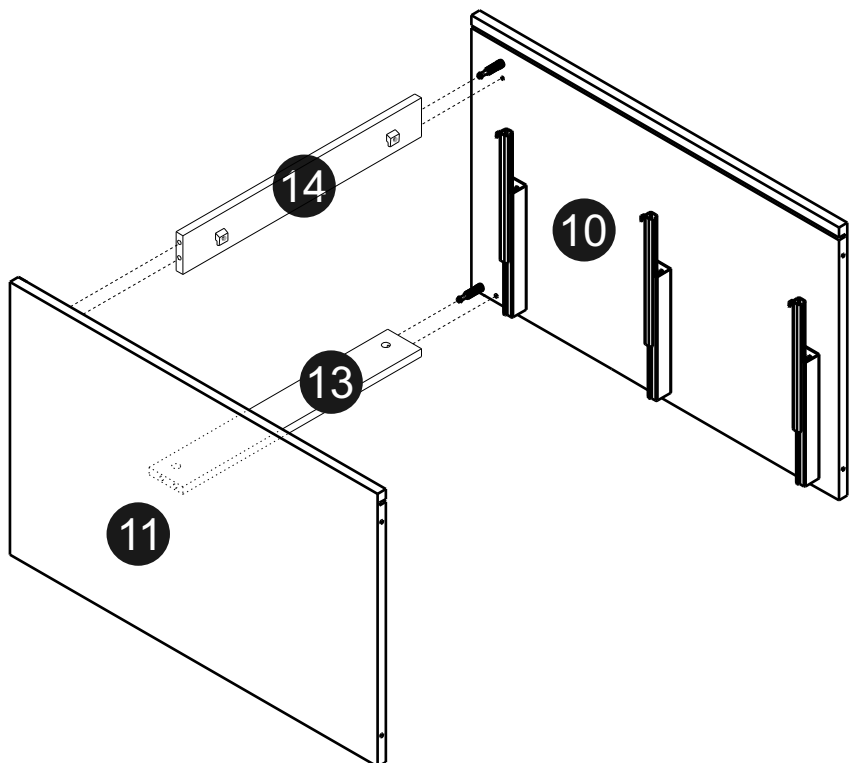

05

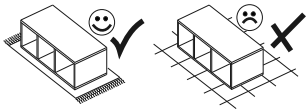

6,4x50			
K3	4	KK1	1

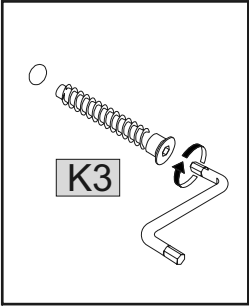
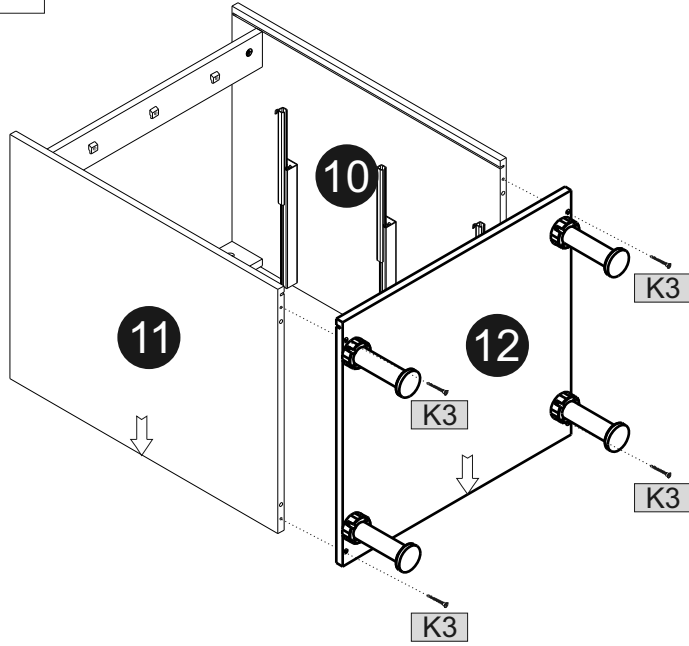

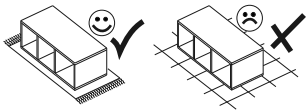

06

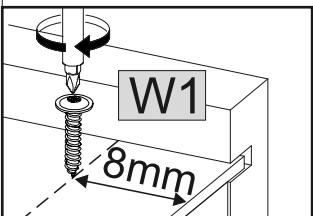
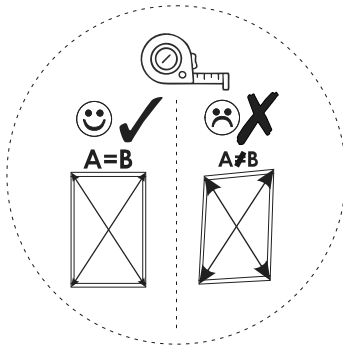
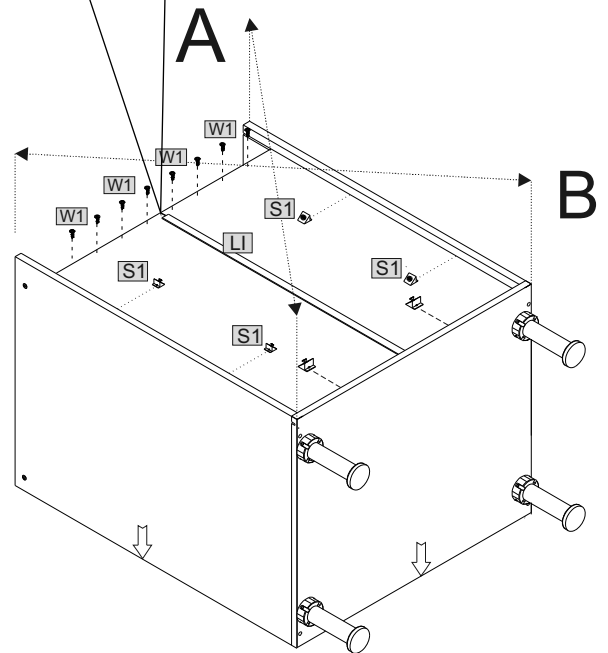
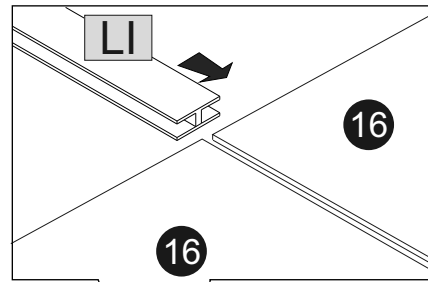
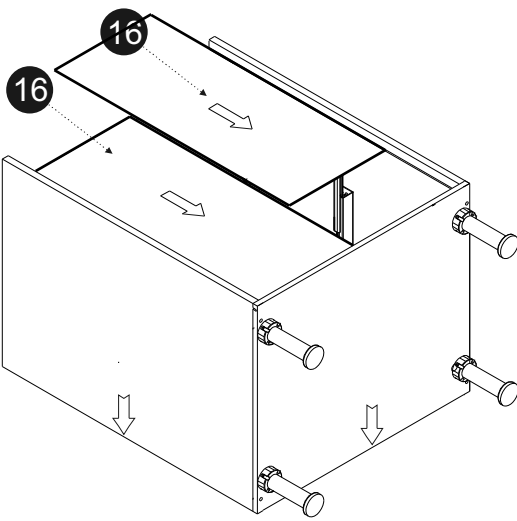

3x16			
W1	8		
S1	6		
LI	1		

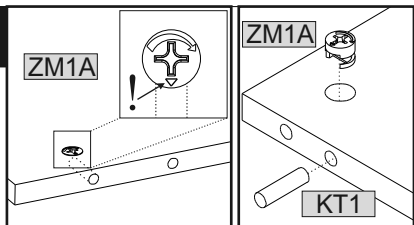



	Ø8x40
KT1	16
	
ZM1A	6

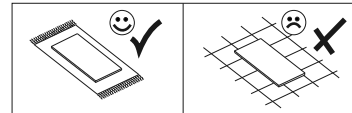
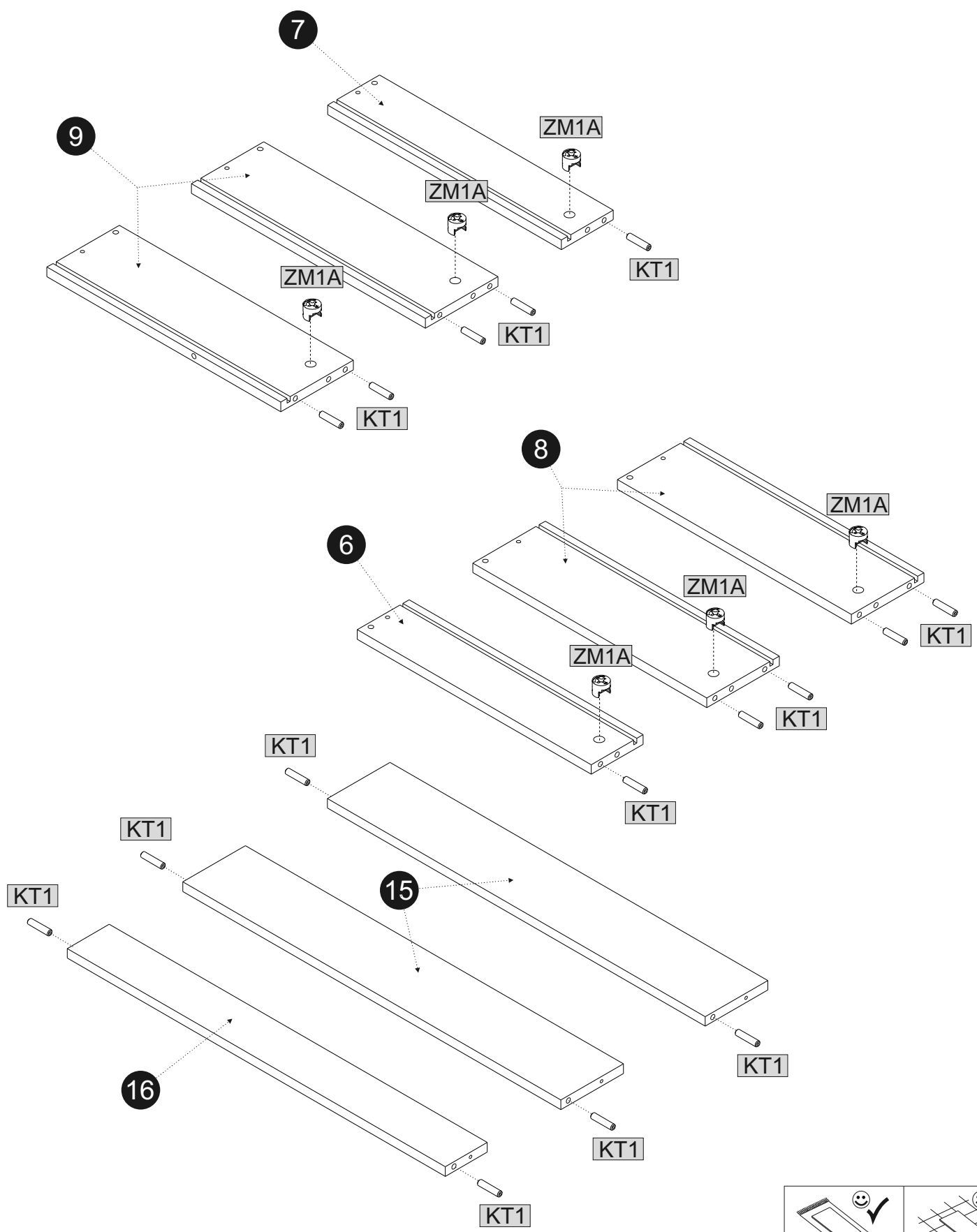

08

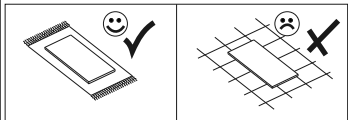
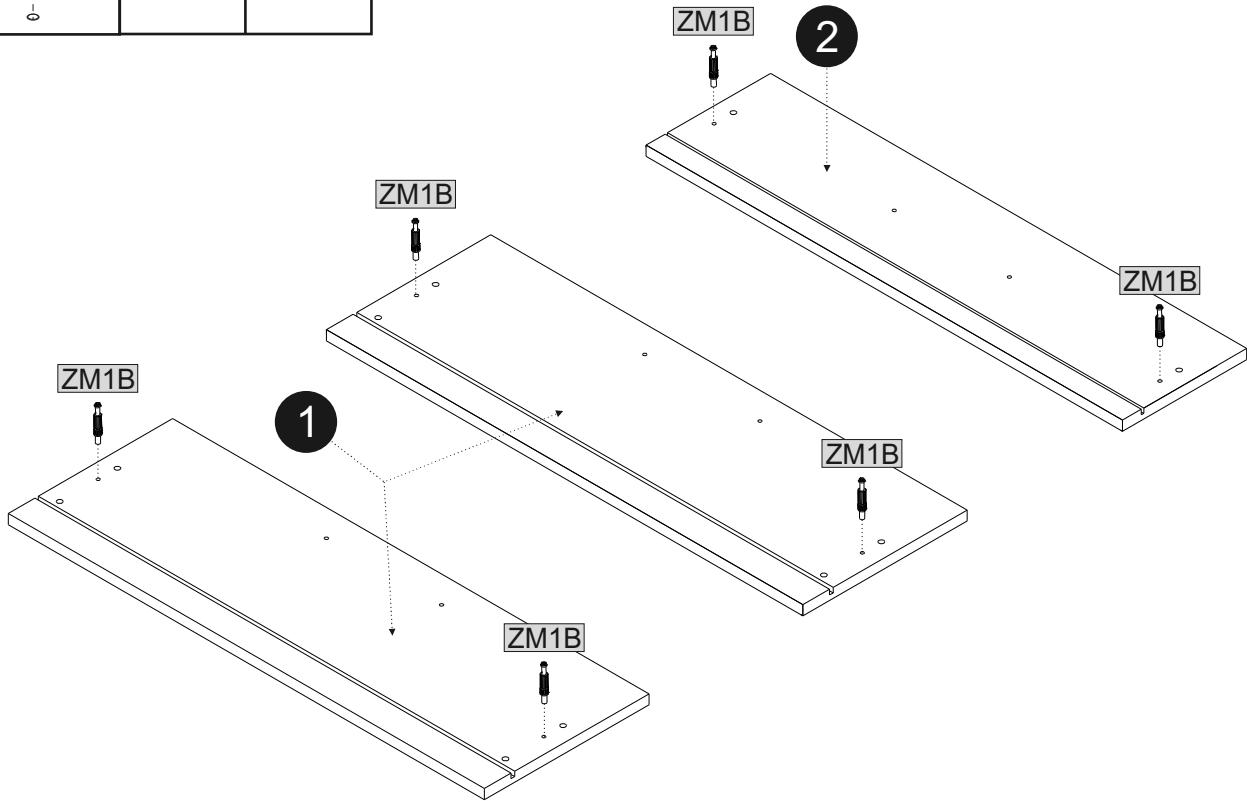
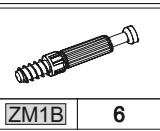
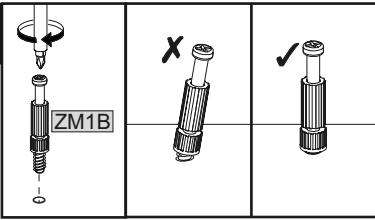

09

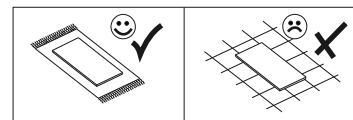
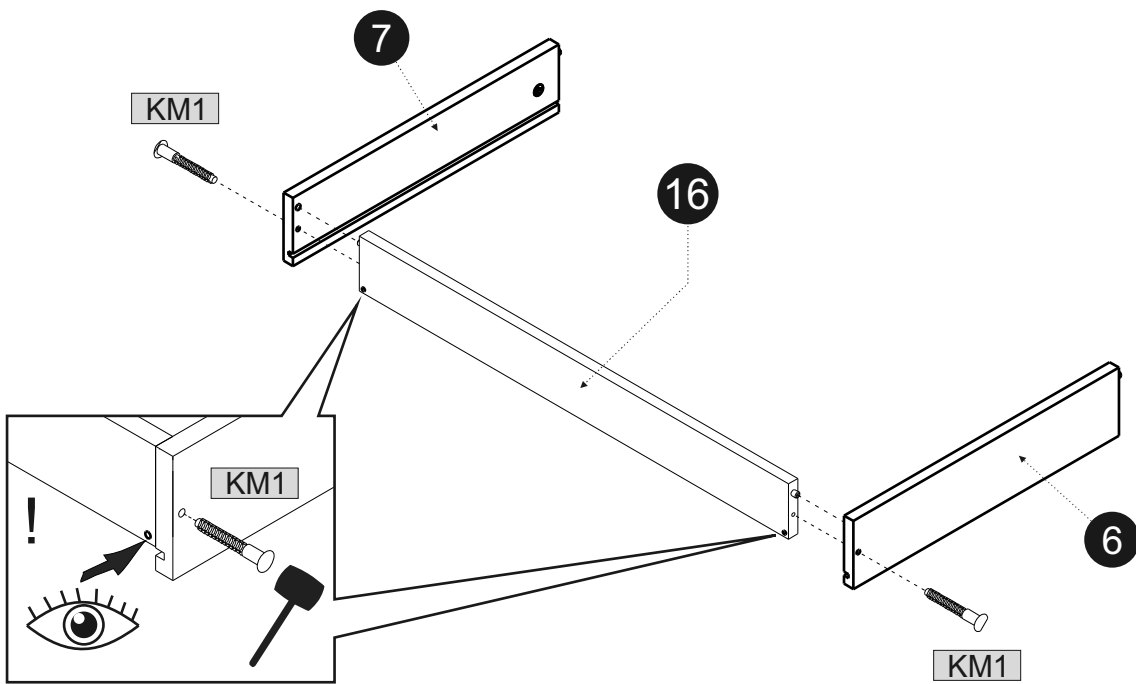
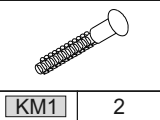



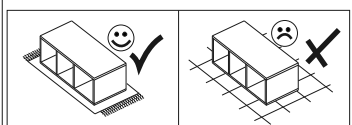
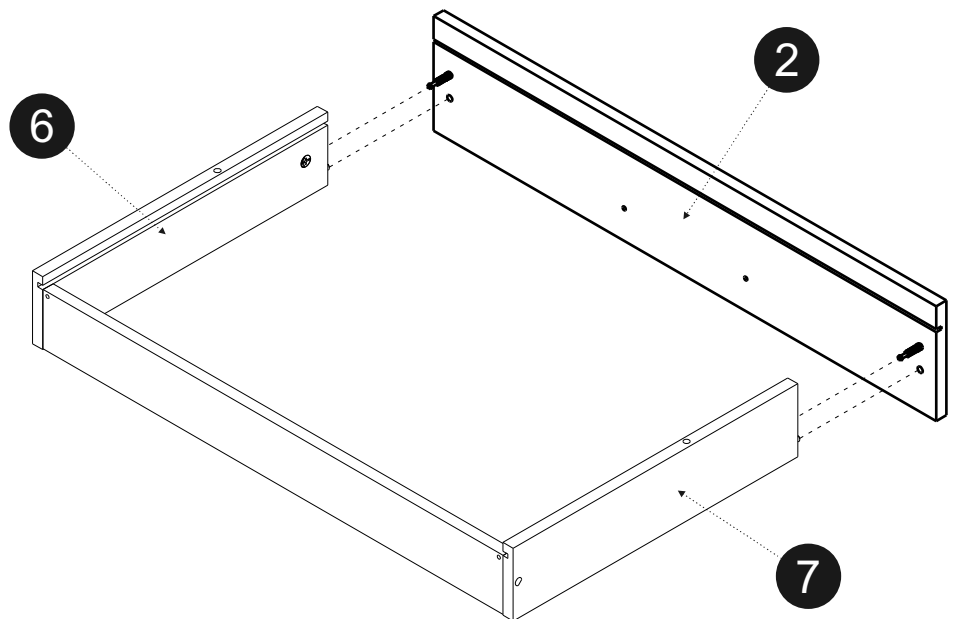
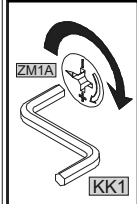
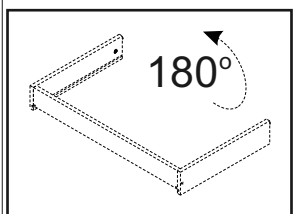

10

	1
--	---



11

	3,5x16						3x16
W11	1	WDS3	1	S1	2	W1	8

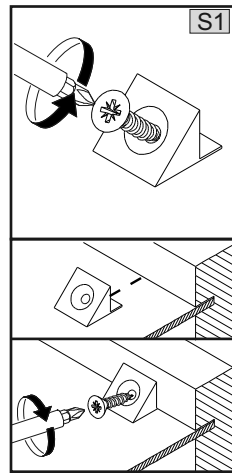
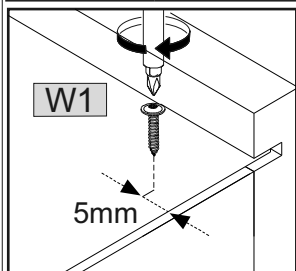
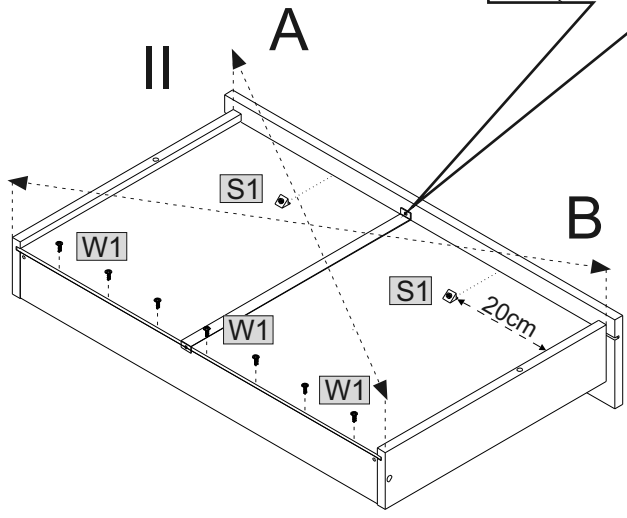
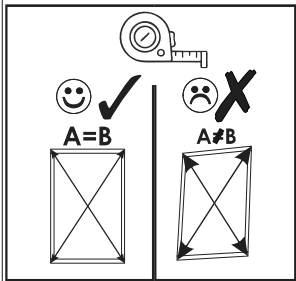
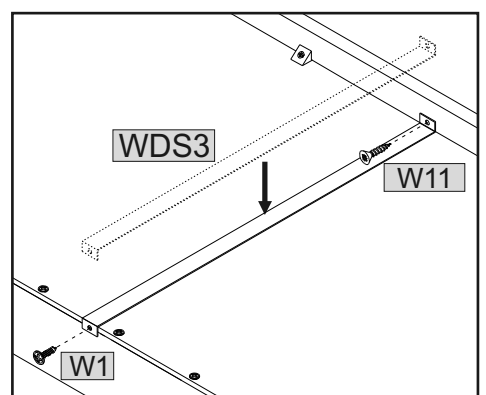
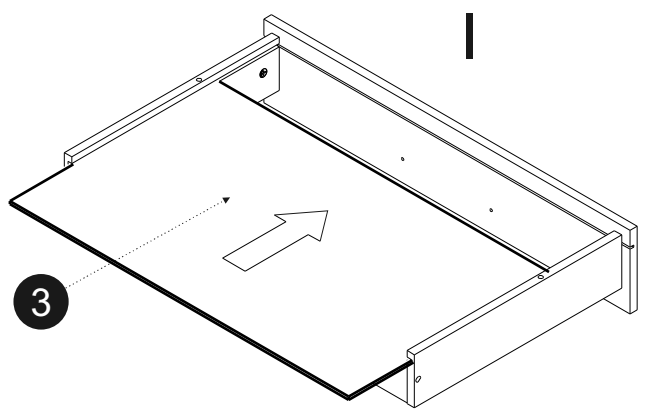

12

2x

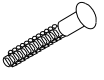
	
KM1	2

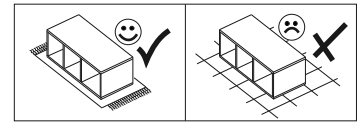
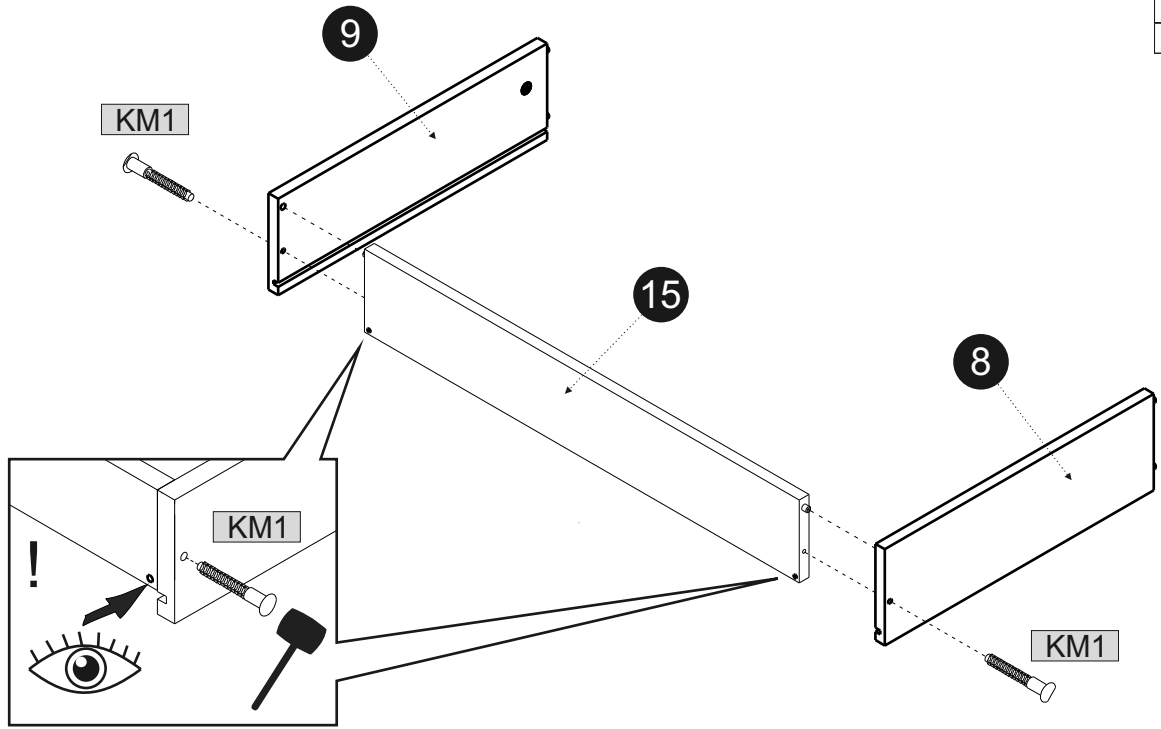

13

2x

	
KK1	1

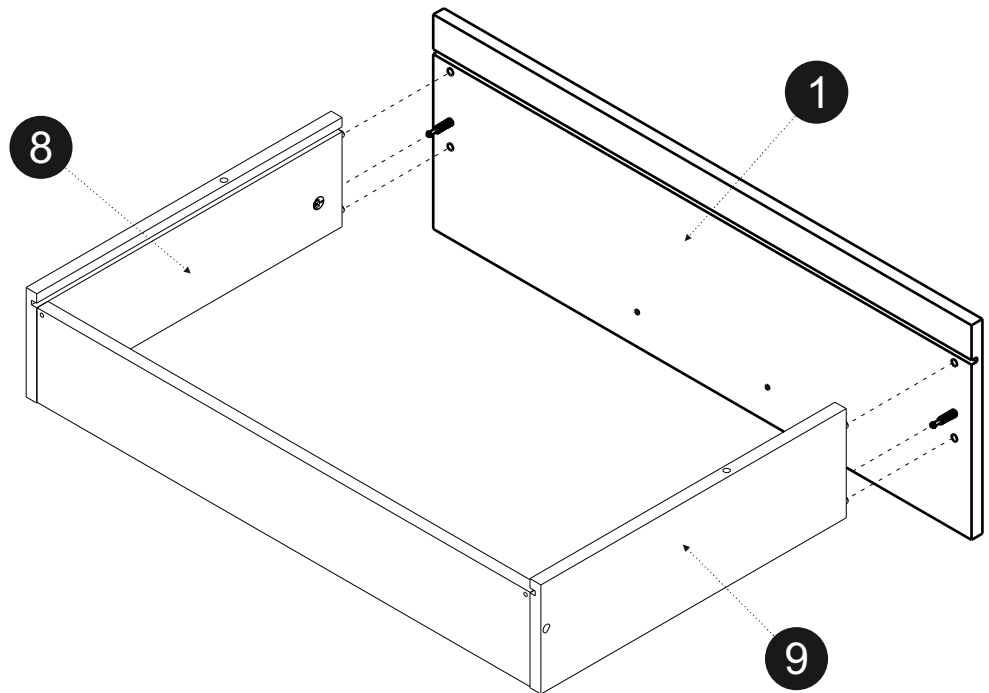
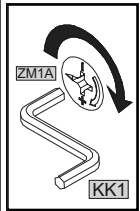
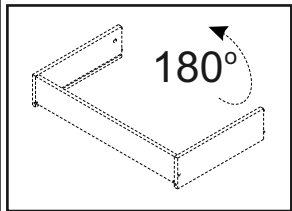



14

2x

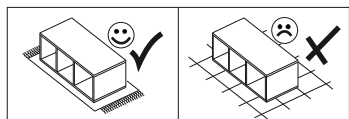
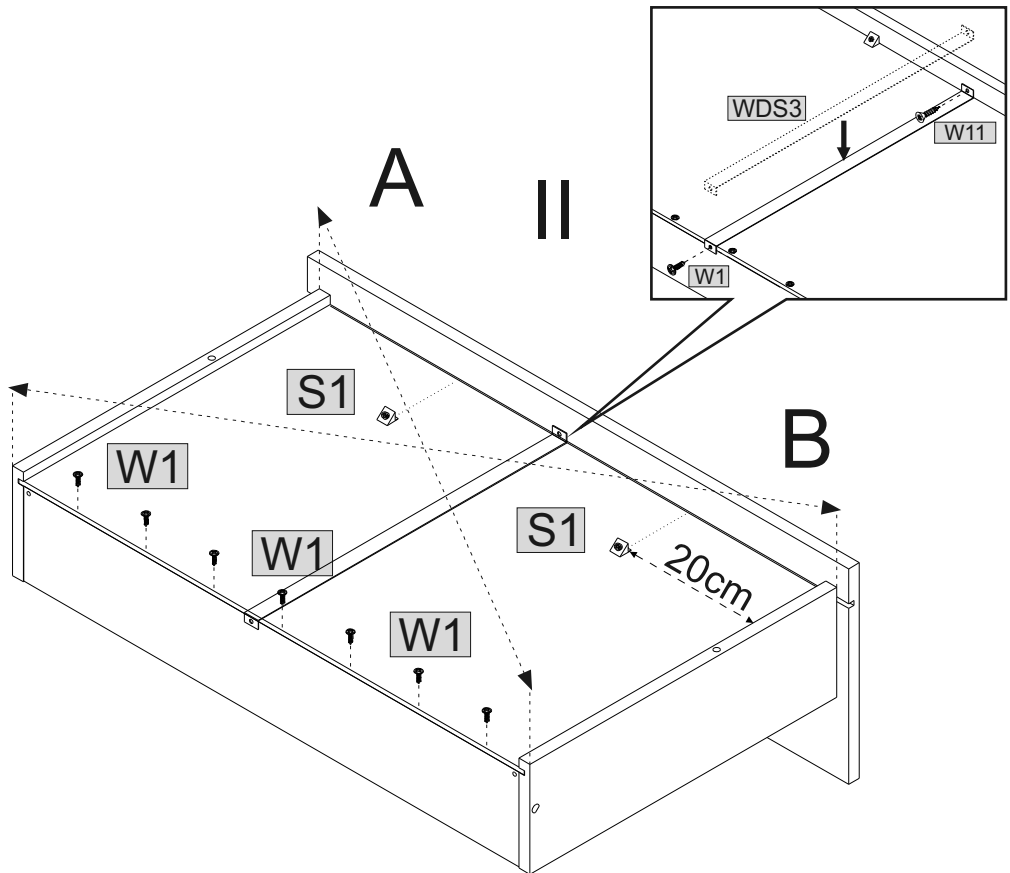
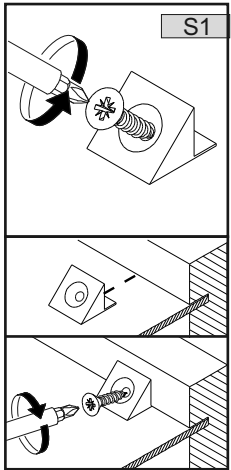
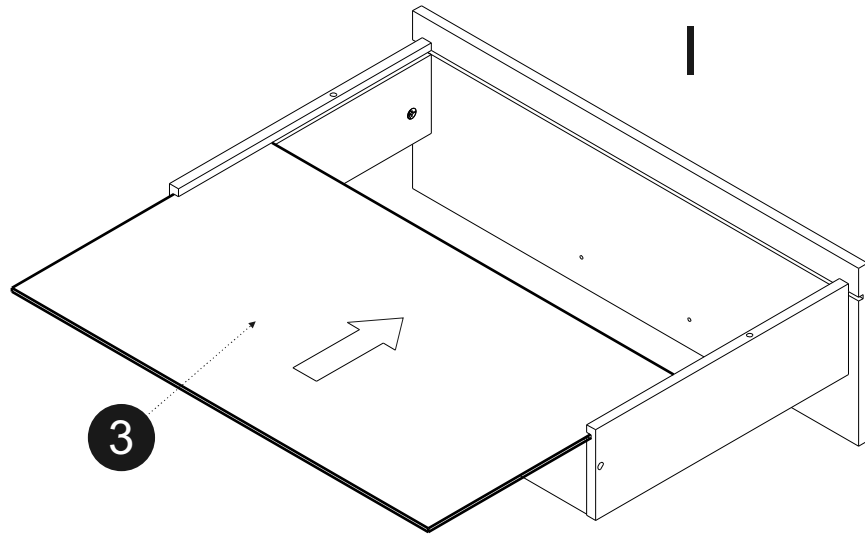
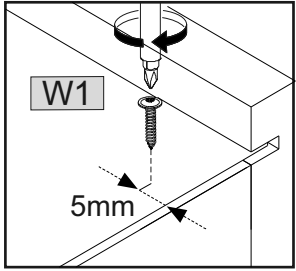
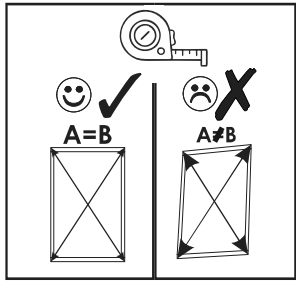
	3,5x16				3x16		
W11	1	WDS3	1	W1	8	S1	2





15

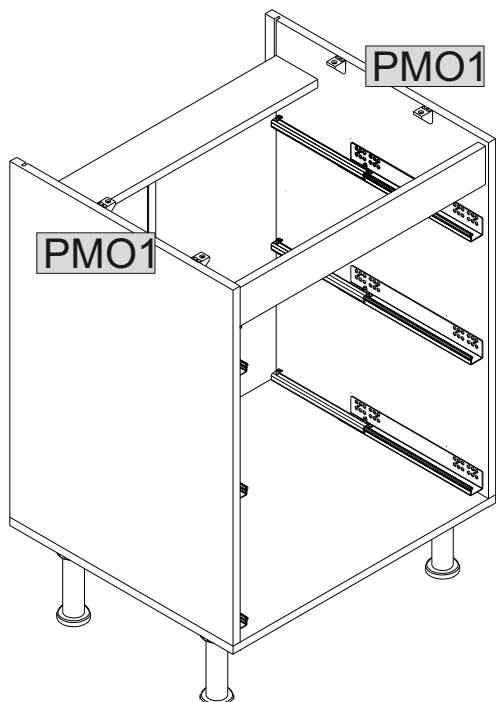
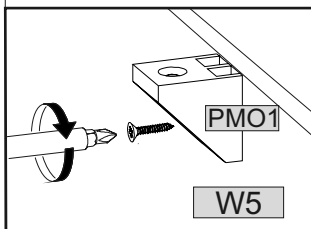



	4x16		
W5	4	PMO1	4

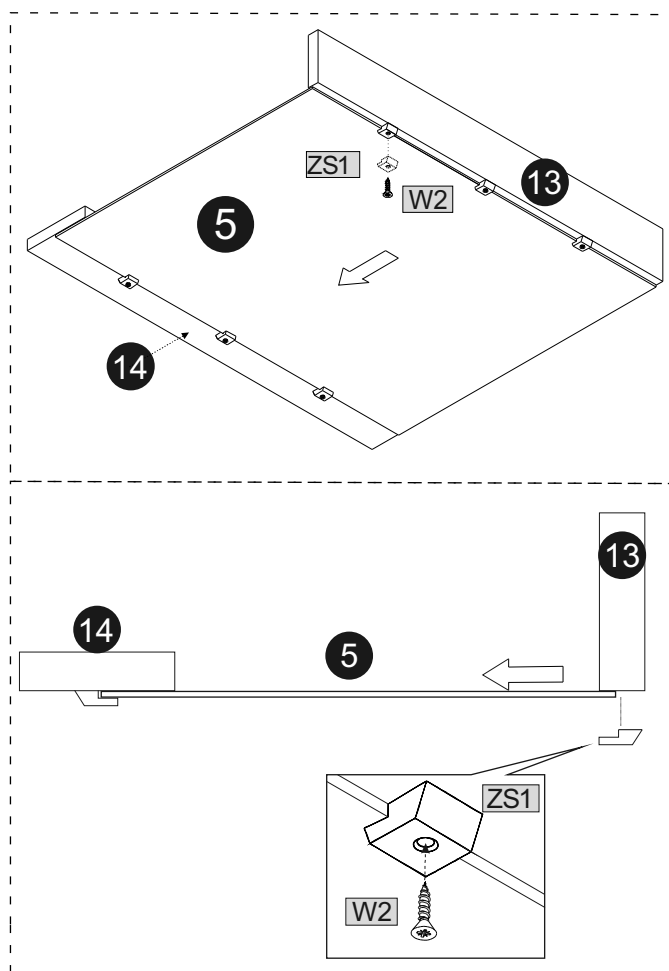
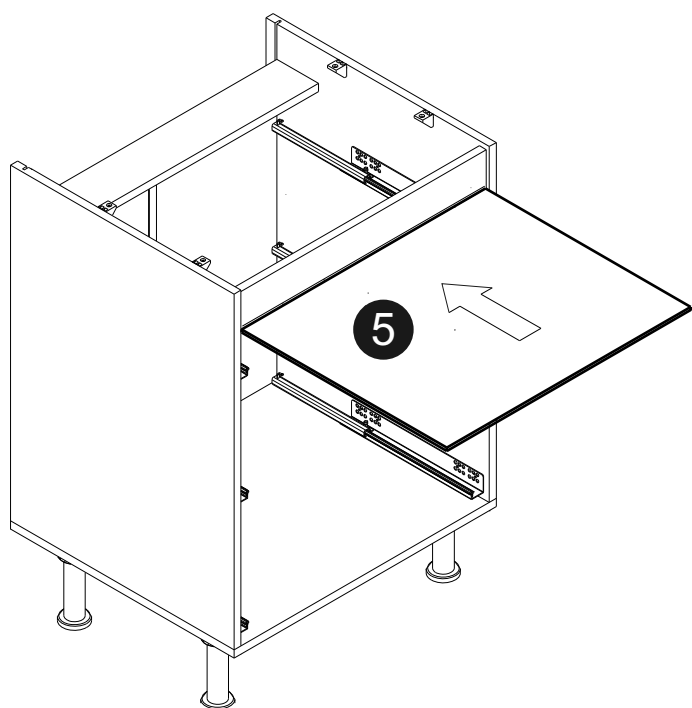

16

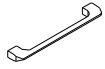
	3x20		
W2	3	ZS1	3



							
U18	3	WU	6	W1	6	ZM1	6

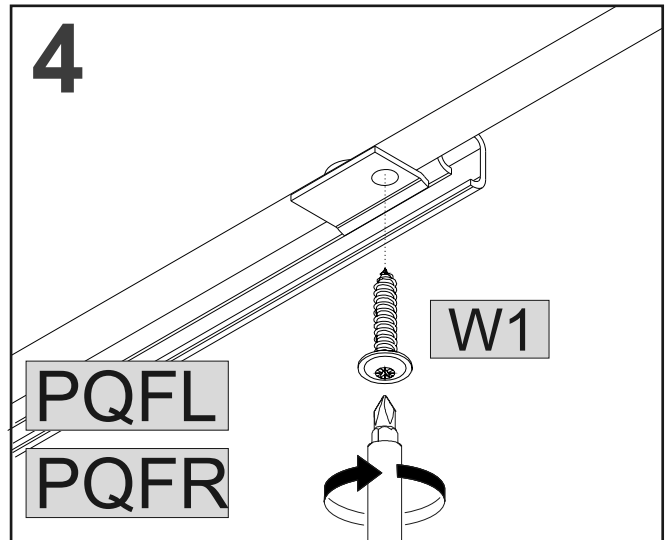
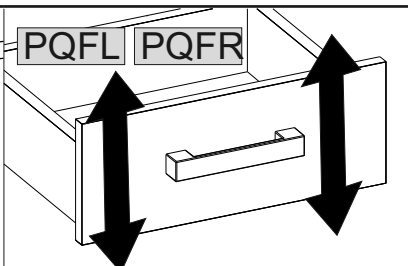
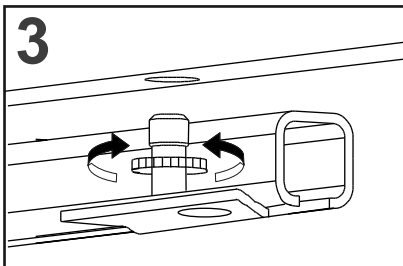
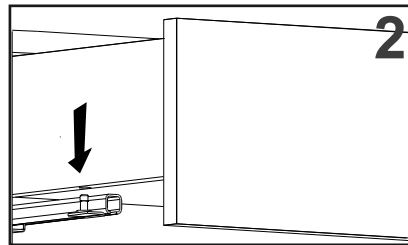
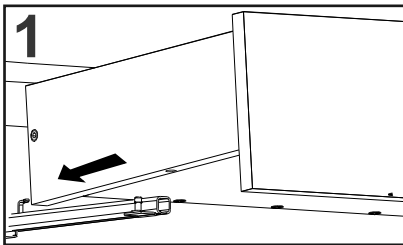
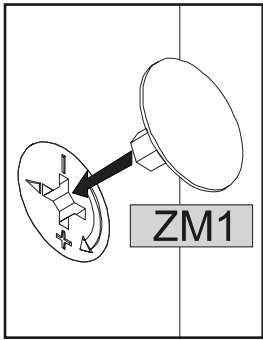
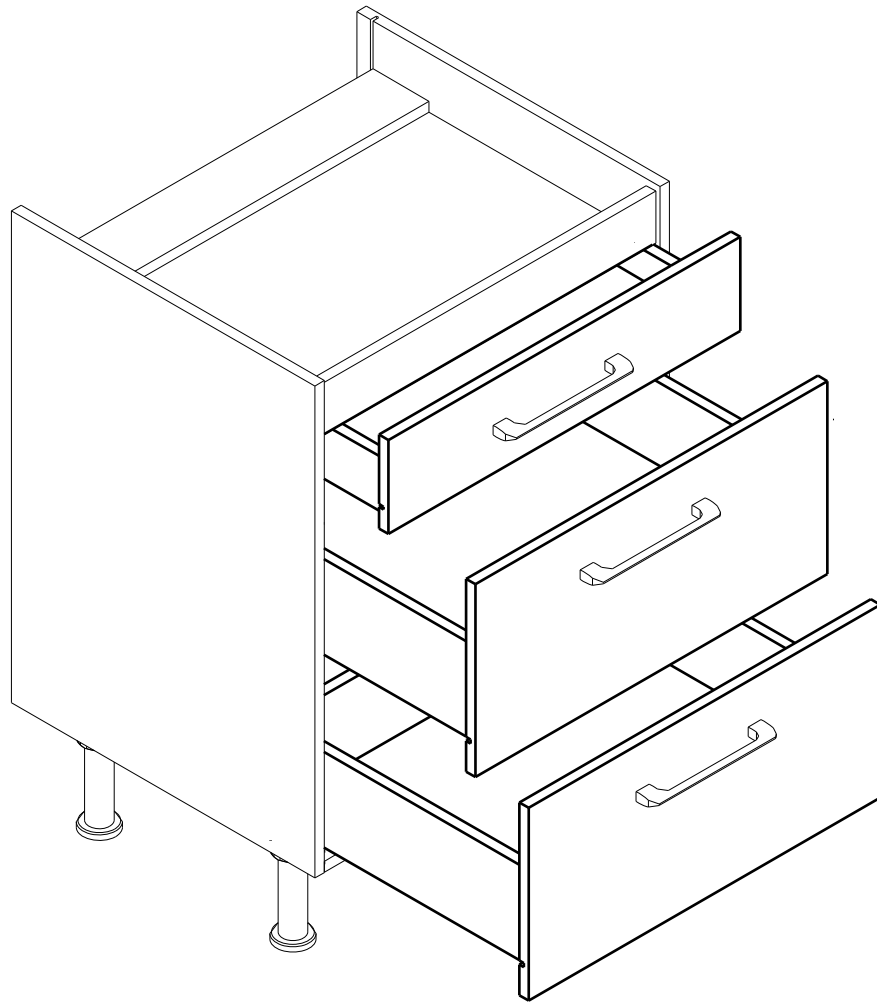

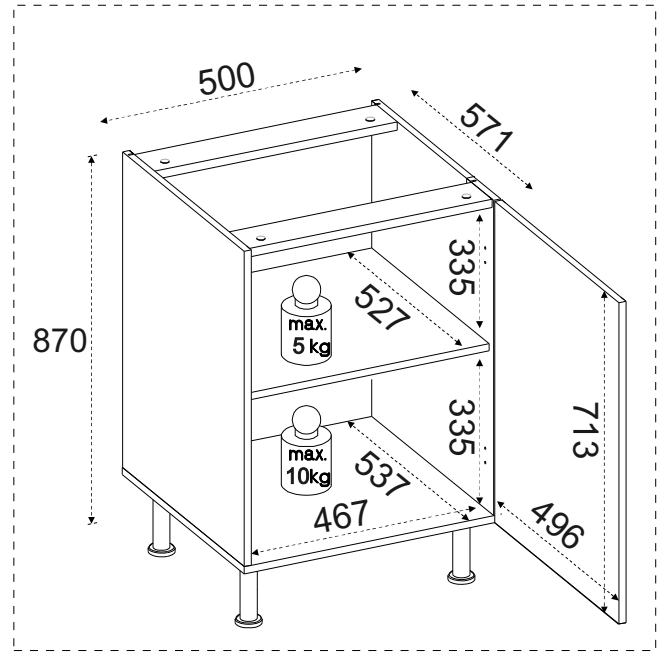
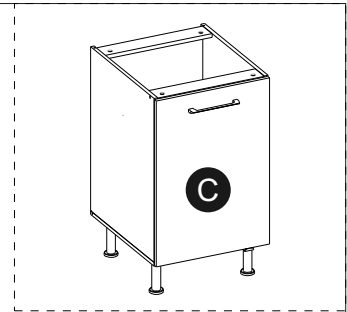
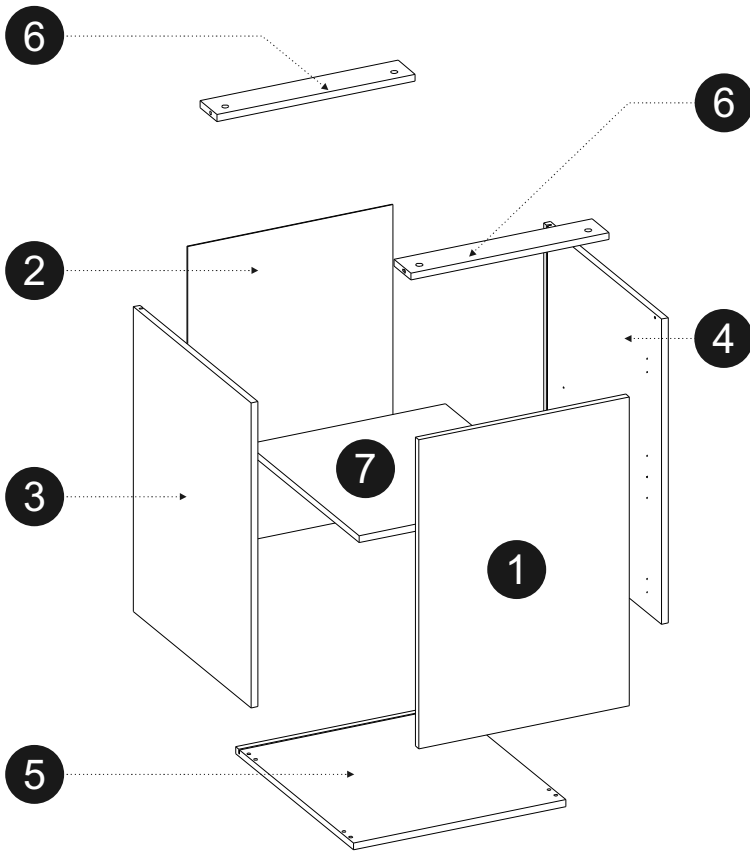

3,5x25	4x13	3x16	3,5x16
WU 2	W4 4	W1 5	W11 20
6,4x50	15x12	Ø8x35	U18
K3 4	ZM1A 4	KT1 4	U18 1
S1 5	KK1 1	NK1 4	
PP 4	KN1 2		

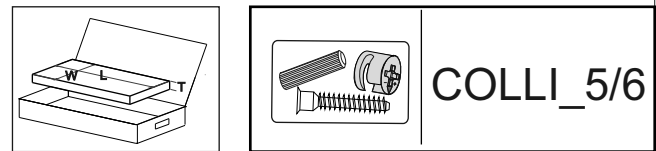

N	L [mm]	W [mm]	T [mm]	Q	COLLI
1	713	496	16	1	COLLI_5/6
2	708	484	3	1	COLLI_5/6
3	704	555	16	1	COLLI_5/6
4	704	555	16	1	COLLI_5/6
5	500	555	16	1	COLLI_5/6
6	467	80	16	2	COLLI_5/6
7	467	527	16	1	COLLI_5/6

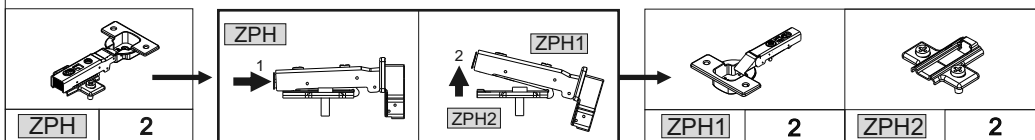

01

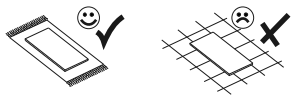

L/P
!

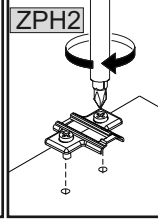
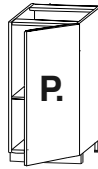
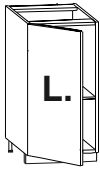

PP

4



ZPH2

2



Ø8x35

KT1

4



15x12

ZM1A

4

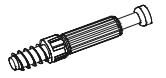

ZM1B

4

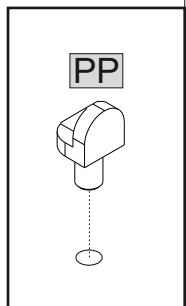
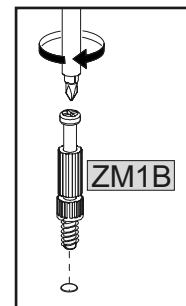
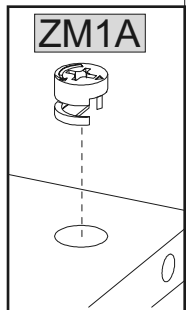
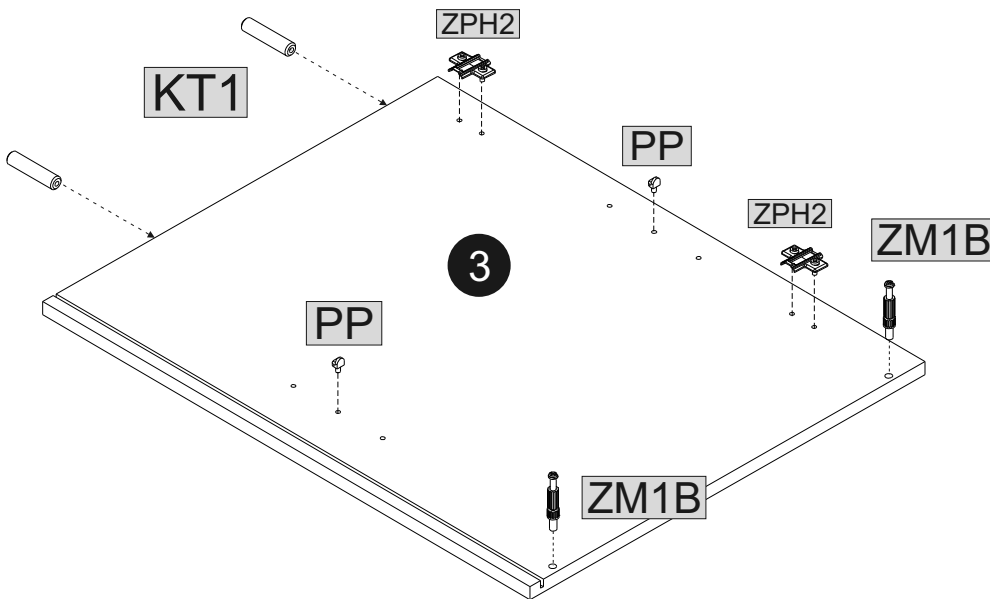
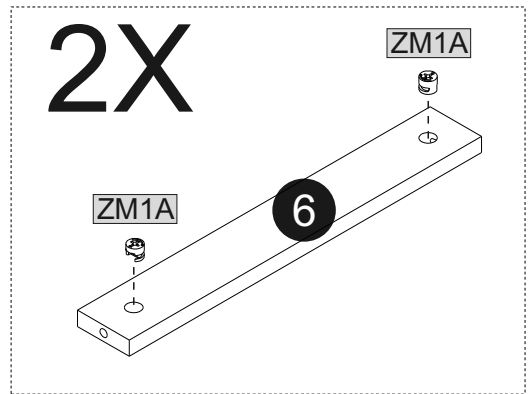
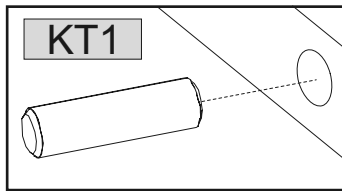
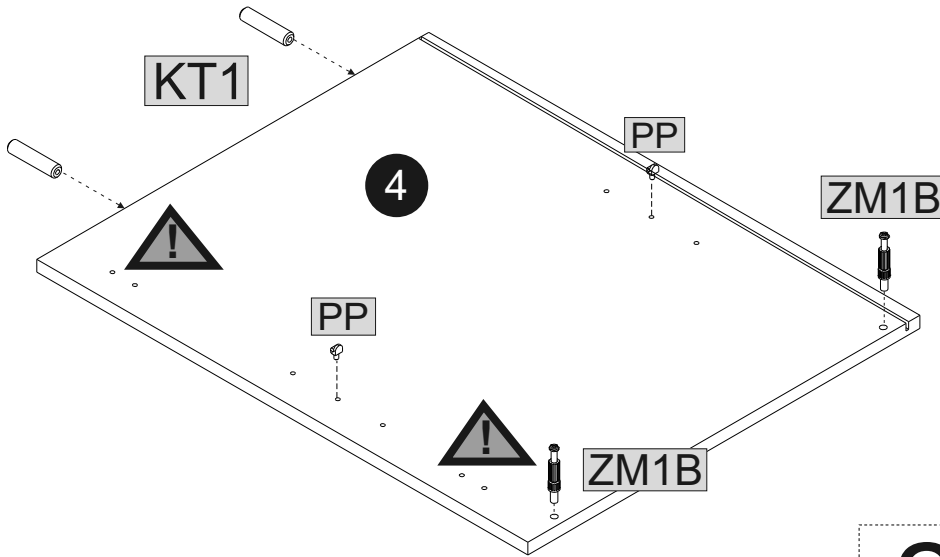

02

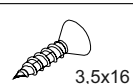
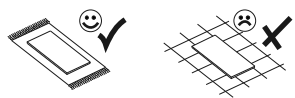

NK1

4

W11

16

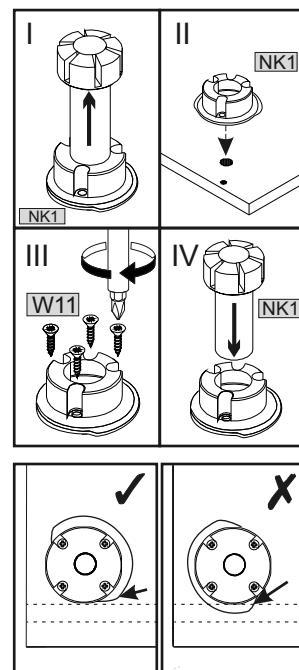
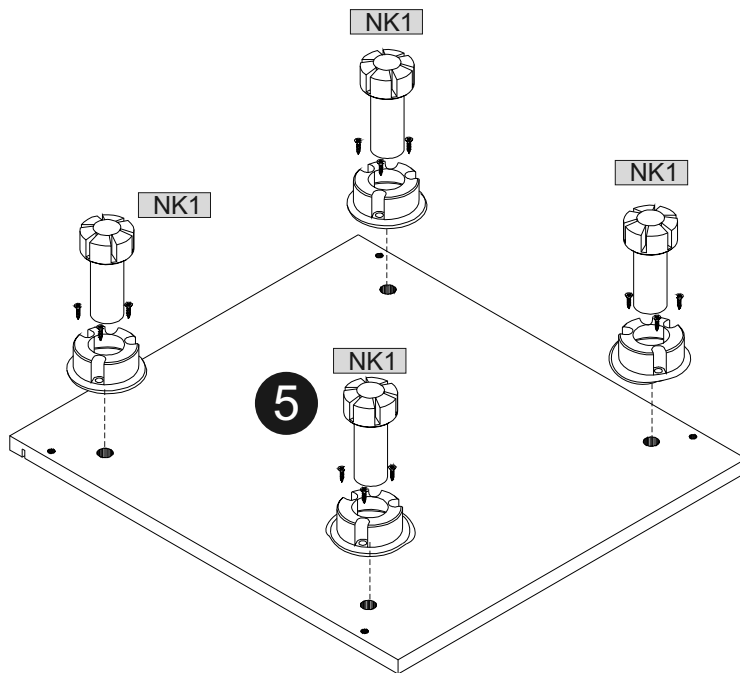
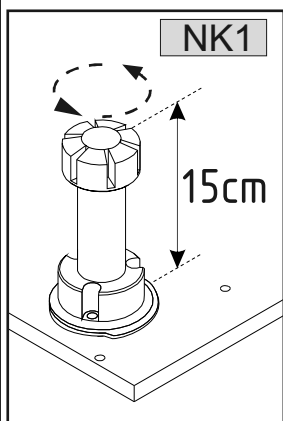

03

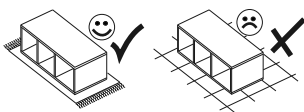

KK1

1

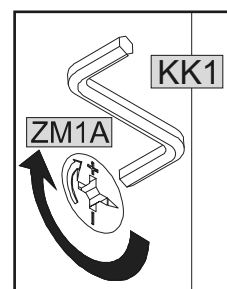
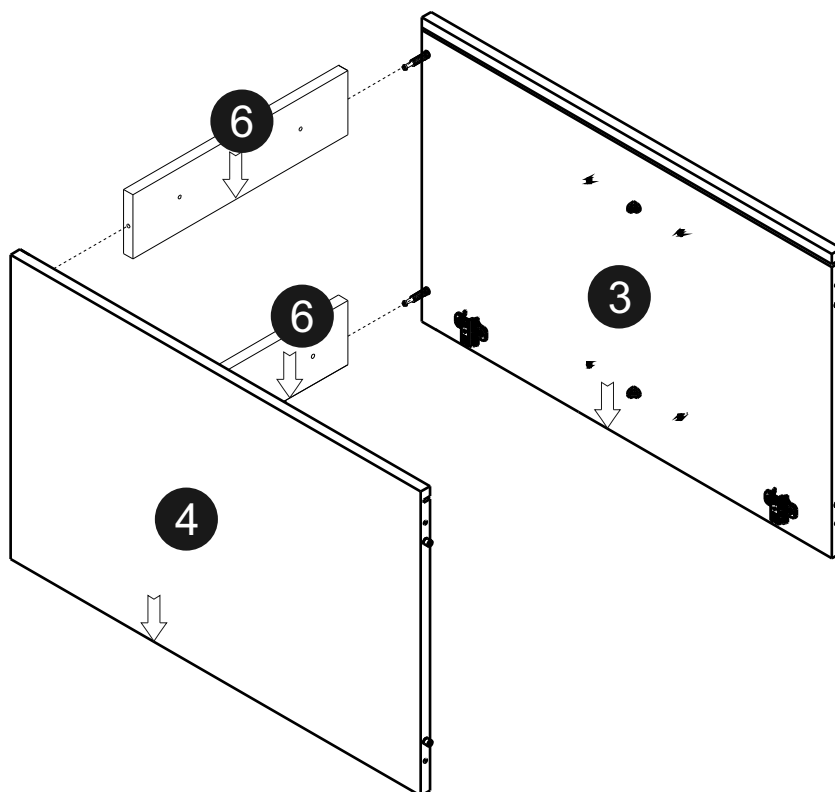

04

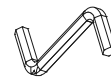
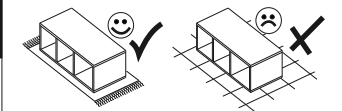

KK1 1



6,4x50

K3 4

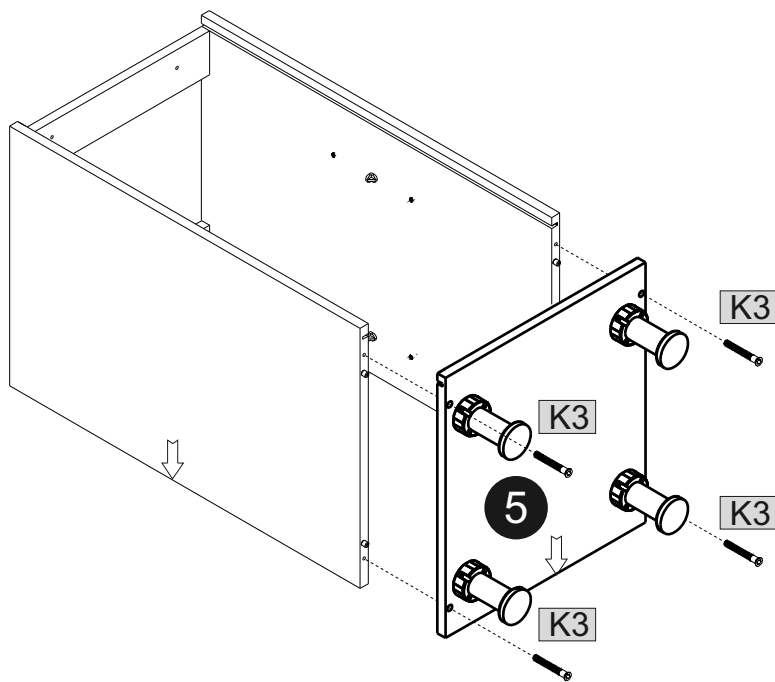
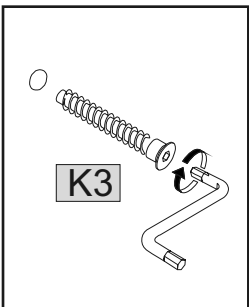

05

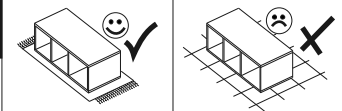

S1 5



3x16

W1 5

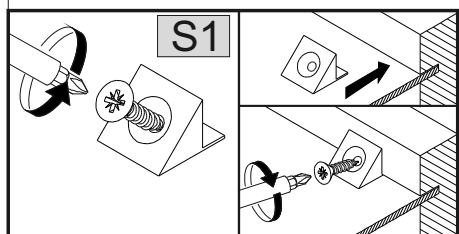
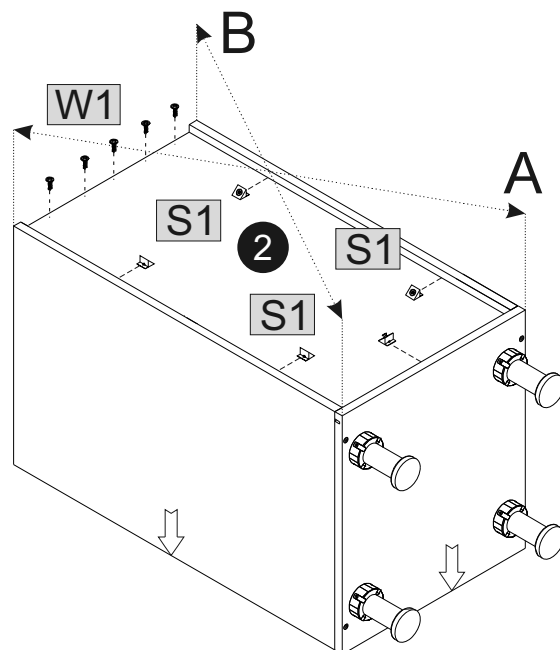
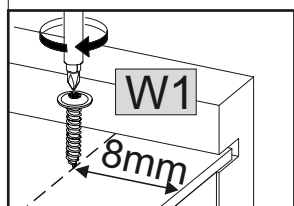
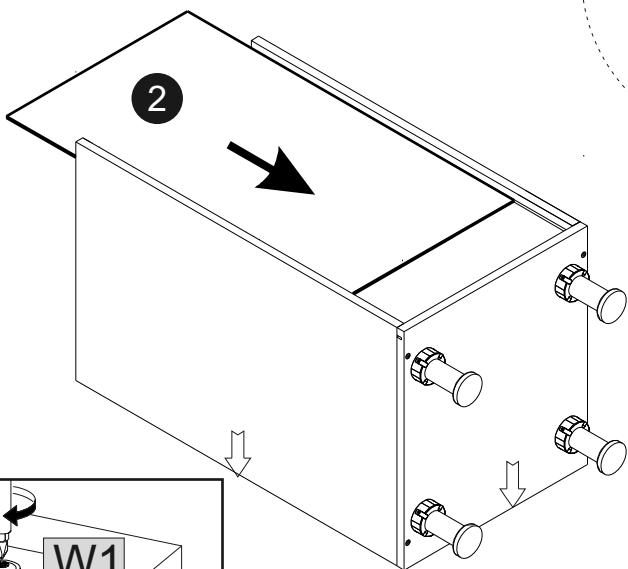
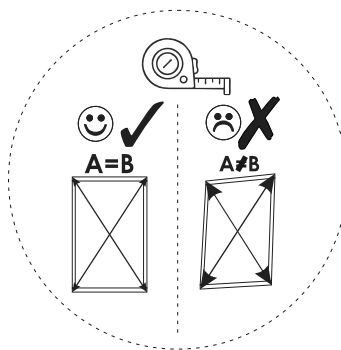

06

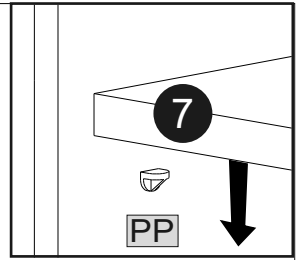
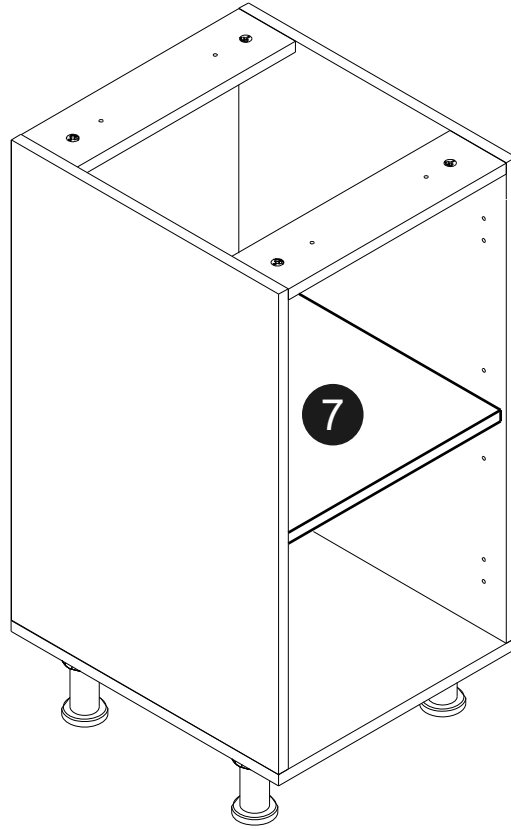

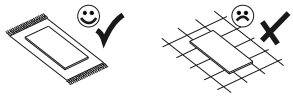

07

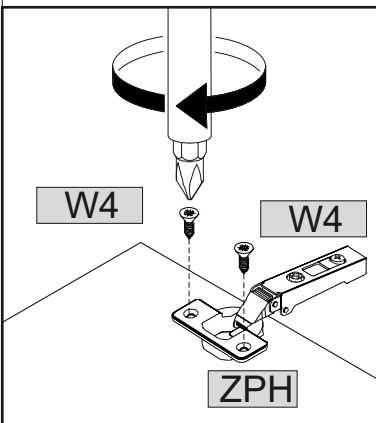
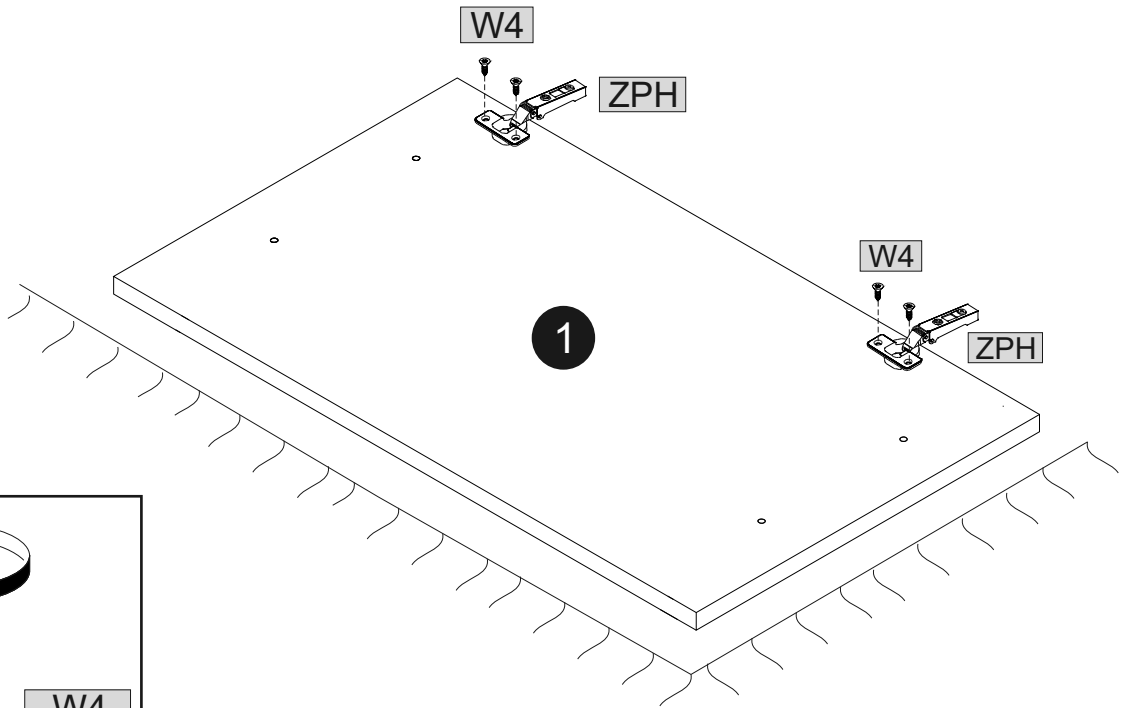

	2		4x13
ZPH1	2	W4	4



			3,5x25
U18	1	WU	2

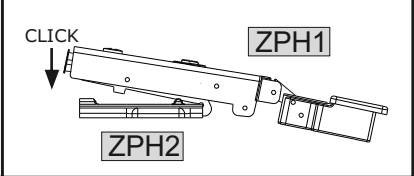
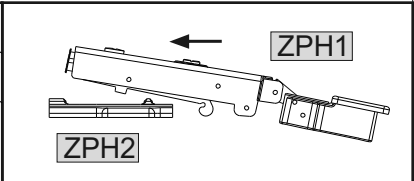
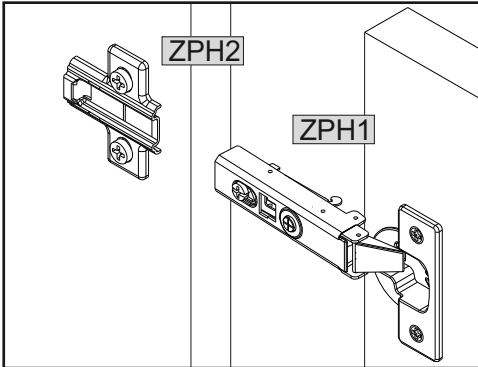
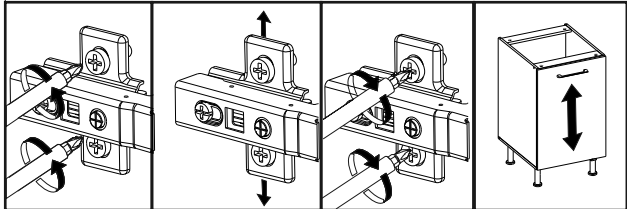
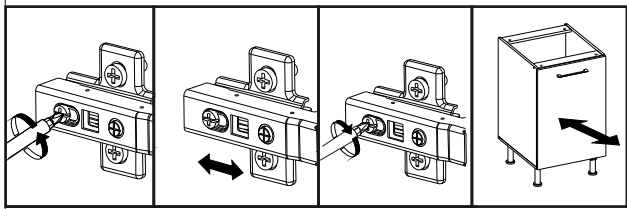
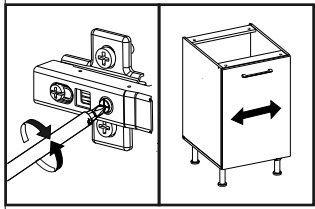
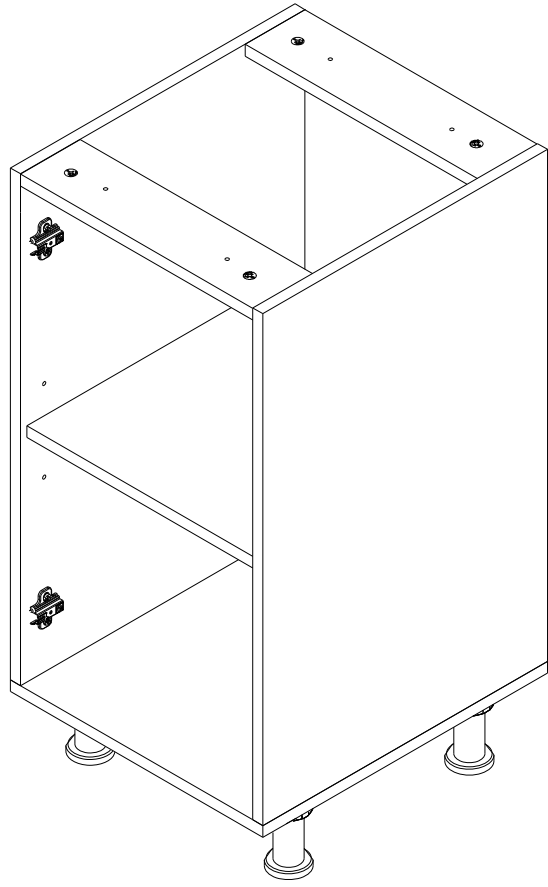
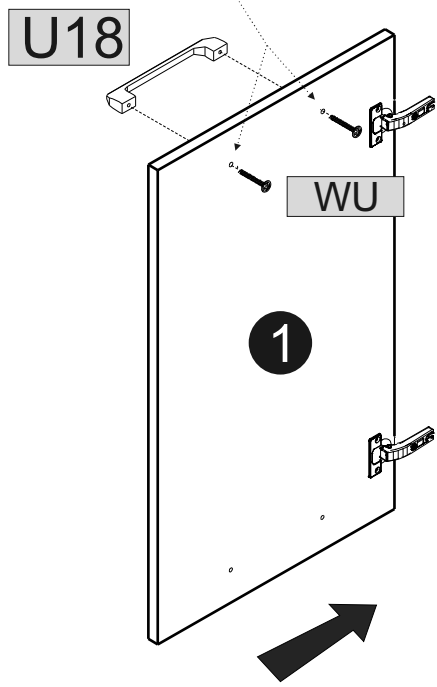
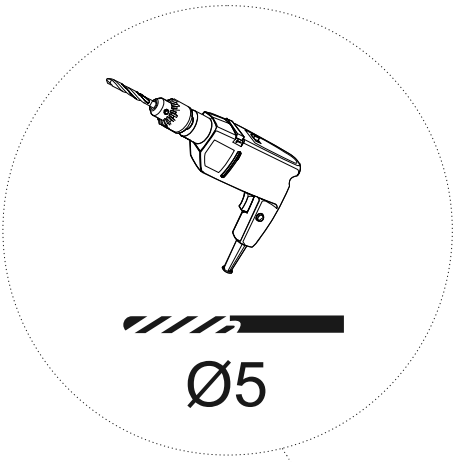

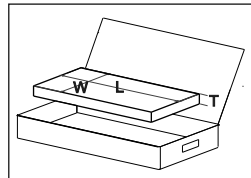
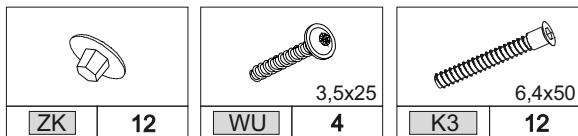
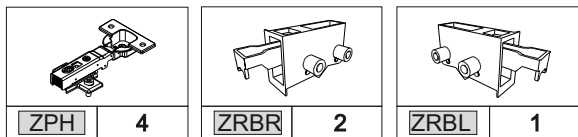
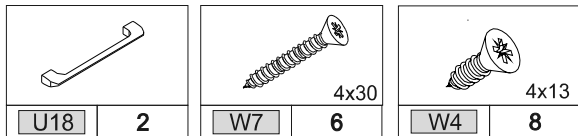
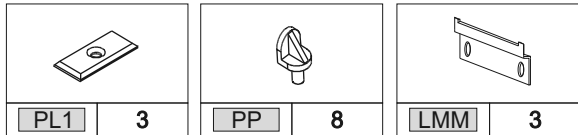
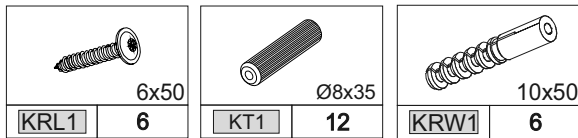
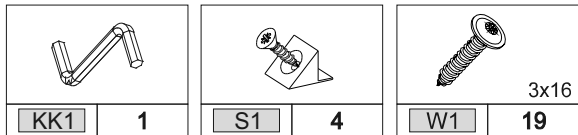
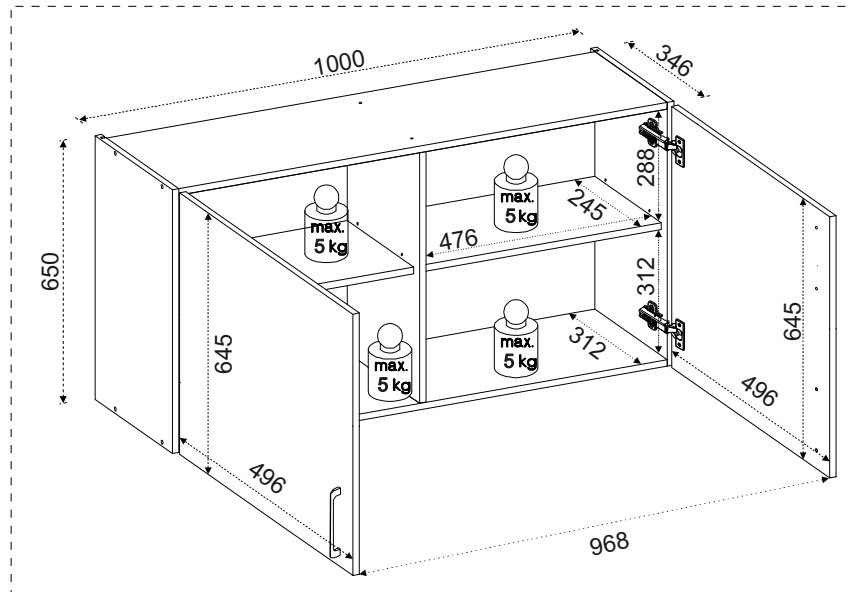
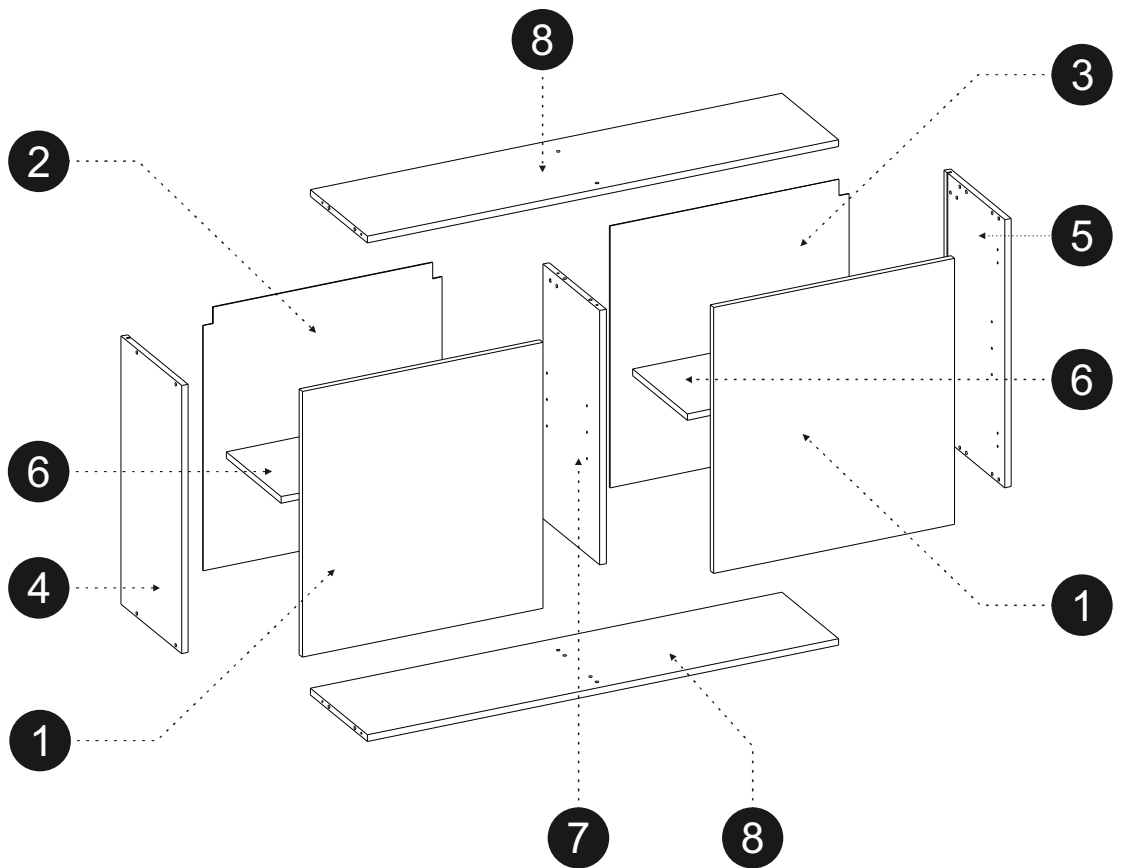
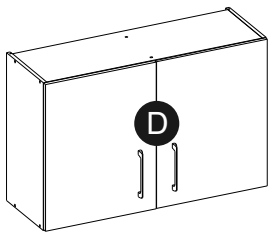

N	L [mm]	W [mm]	T [mm]	Q	COLLI
1	645	496	16	2	COLLI_4/6
2	646	492	3	1	COLLI_4/6
3	646	492	3	1	COLLI_4/6
4	650	330	16	1	COLLI_4/6
5	650	330	16	1	COLLI_4/6
6	476	245	16	2	COLLI_4/6
7	617	312	16	1	COLLI_4/6
8	968	312	16	2	COLLI_4/6

01

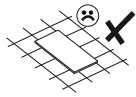
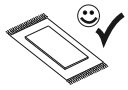

	2		1		6		12
				4x30		Ø8x40	

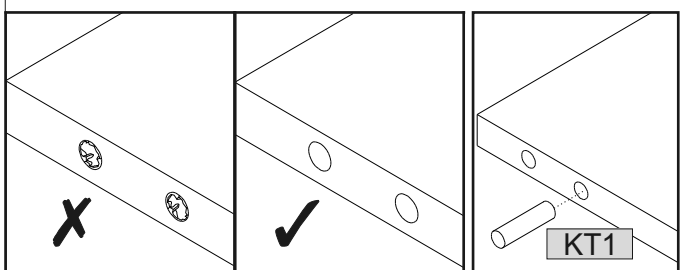
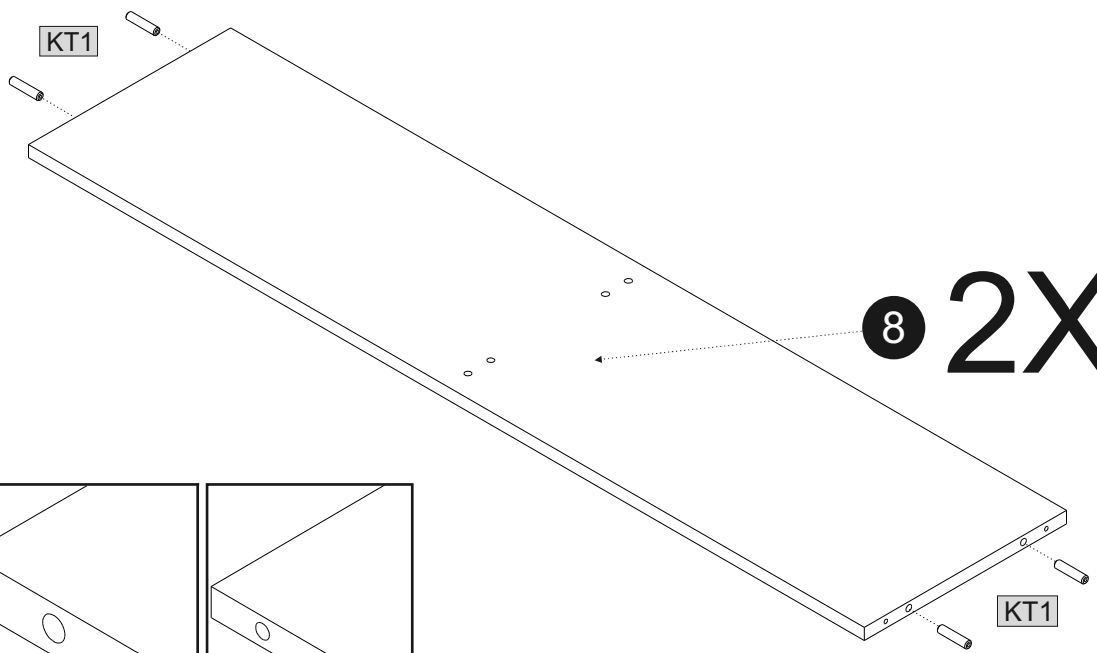
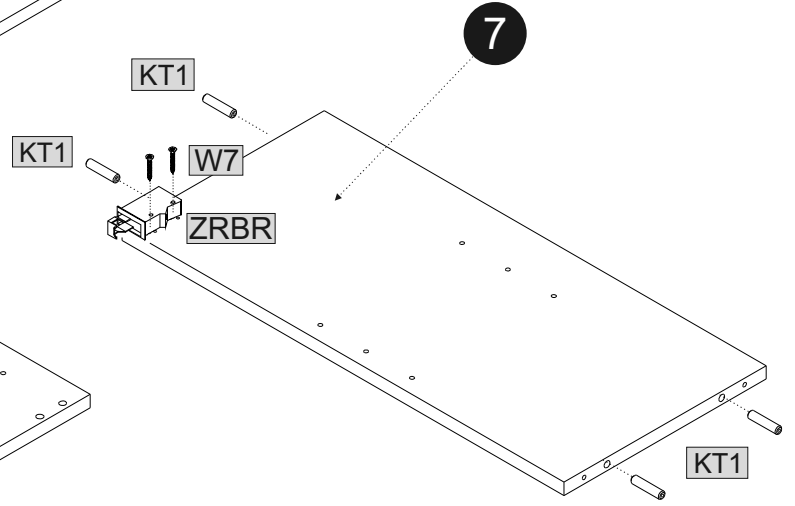
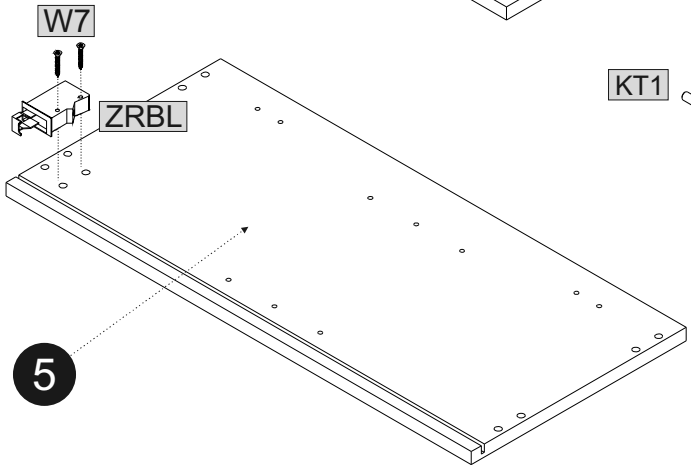
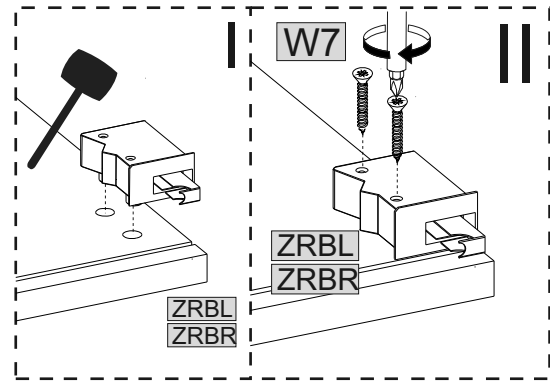
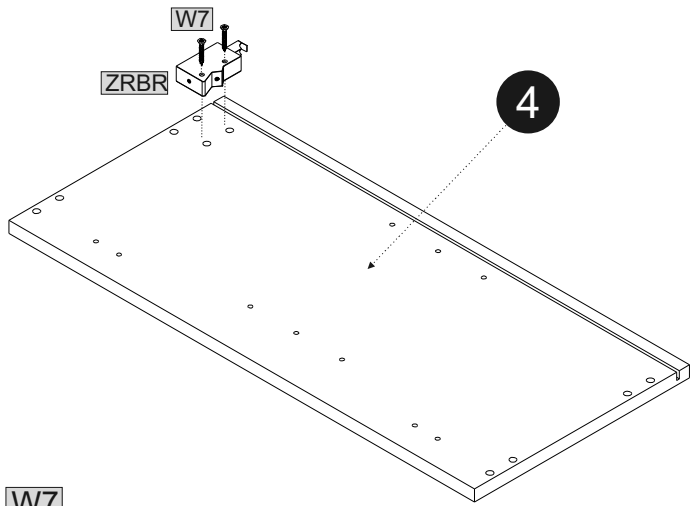

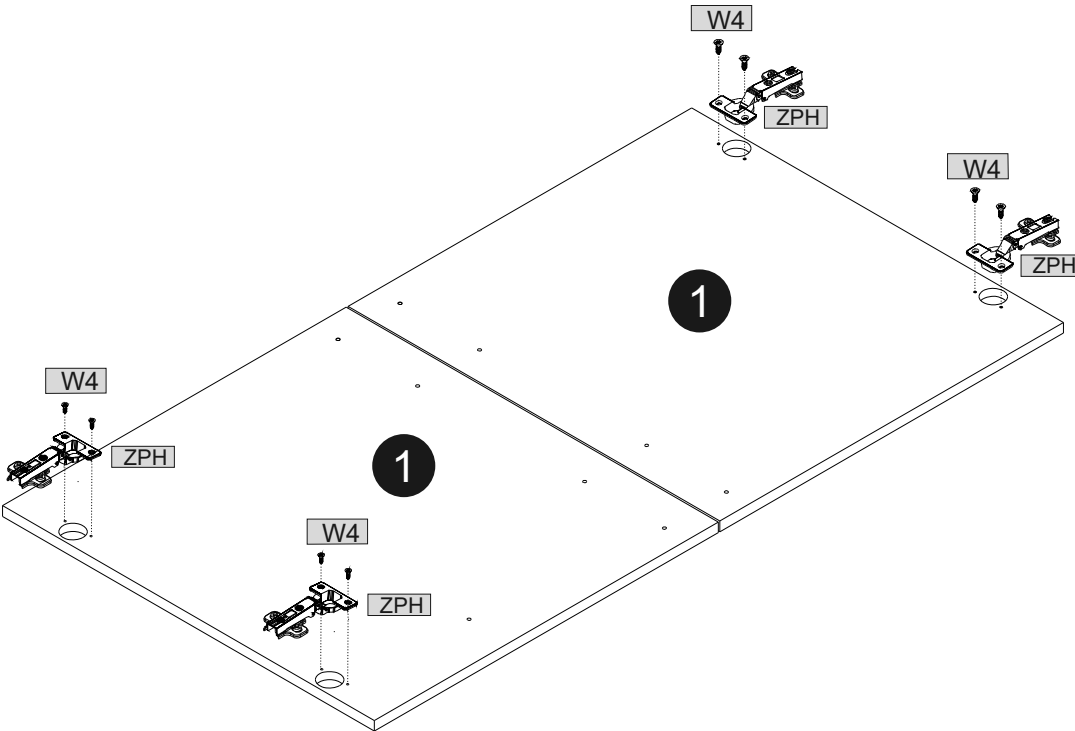
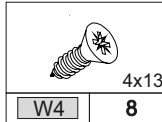
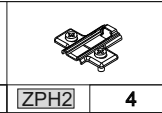
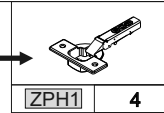
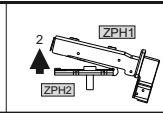
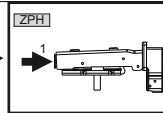
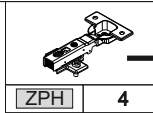
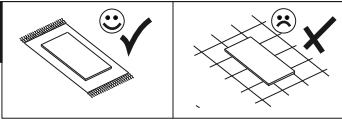

02

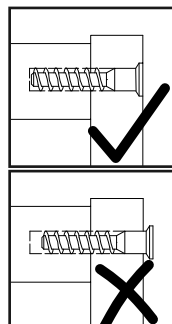
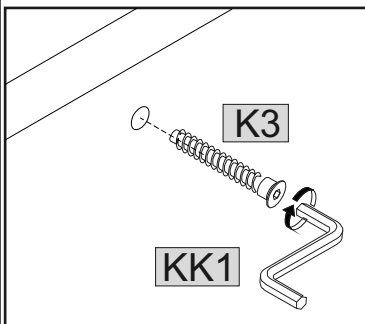
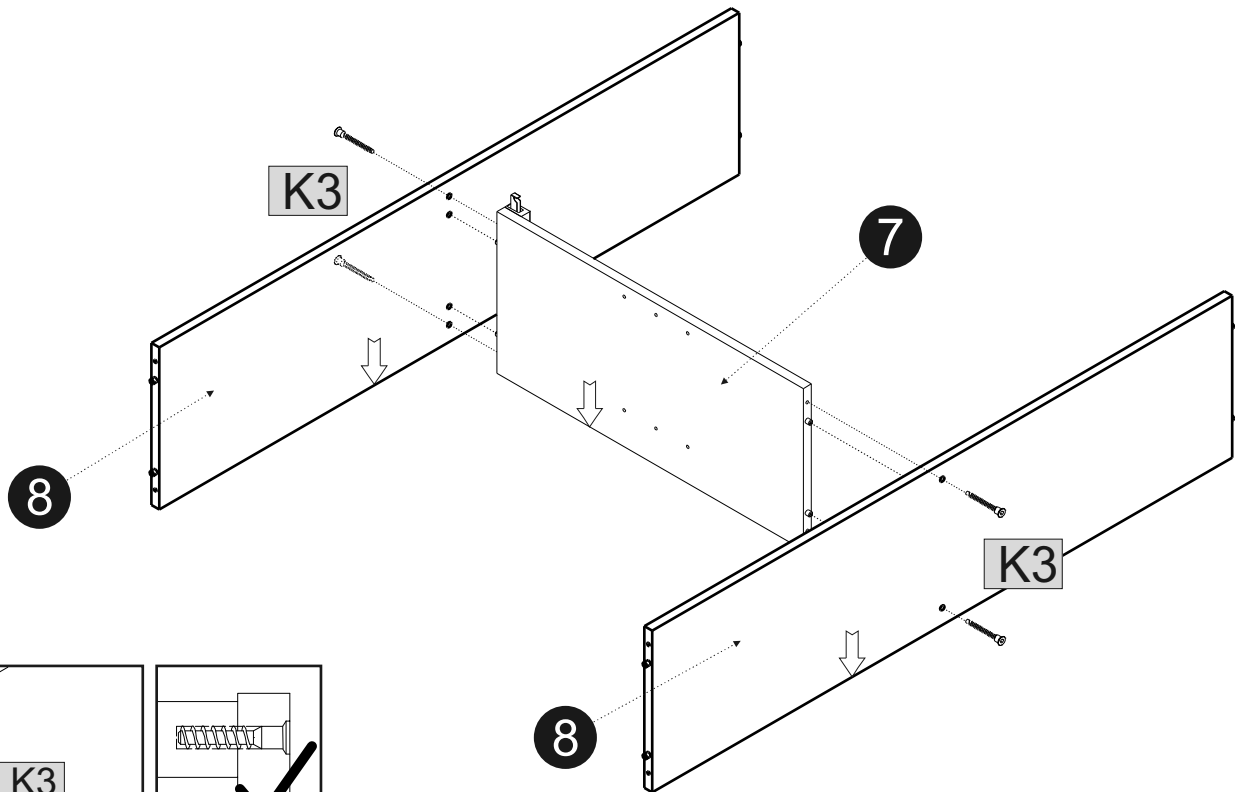
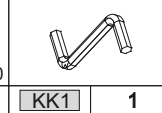
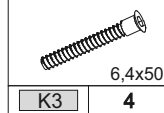
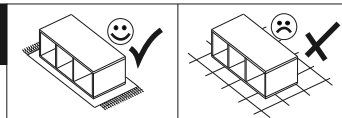

03

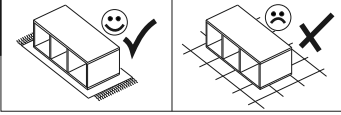

04

	6,4x50		
K3	8	KK1	1

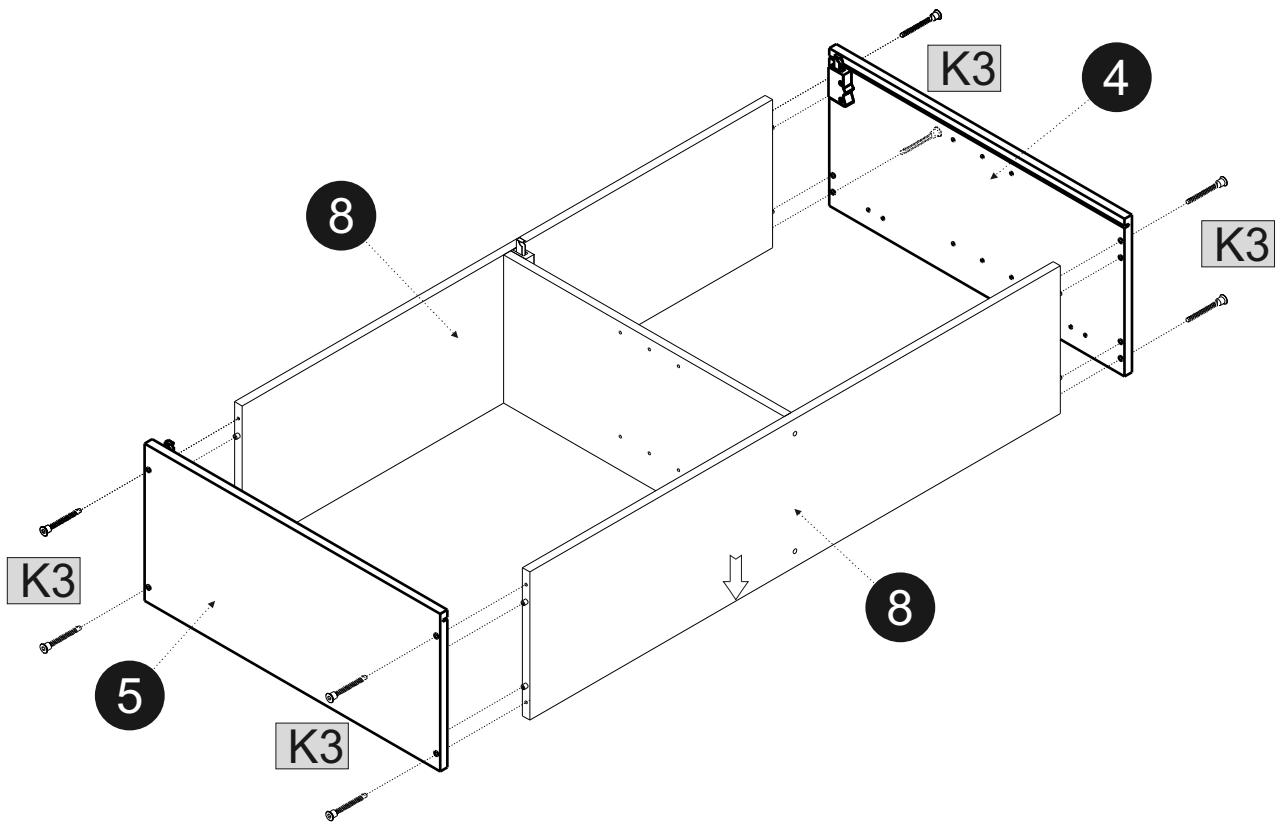
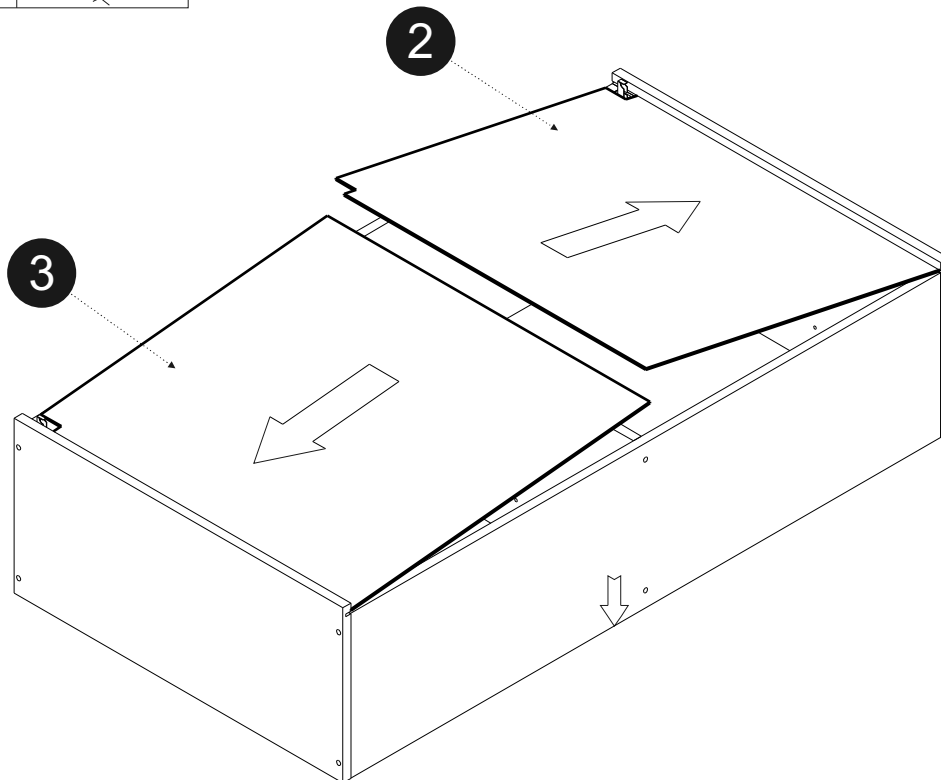
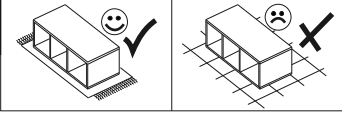
**05**

06

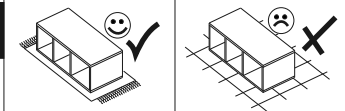

			3x16		
S1	4	W1	19	PL1	3

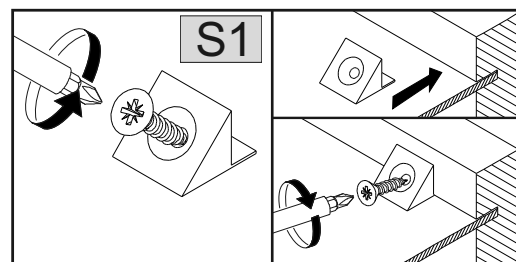
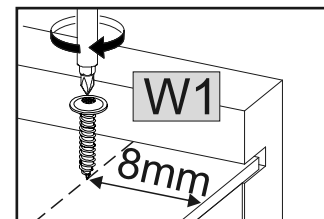
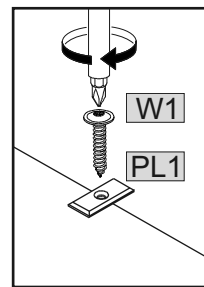
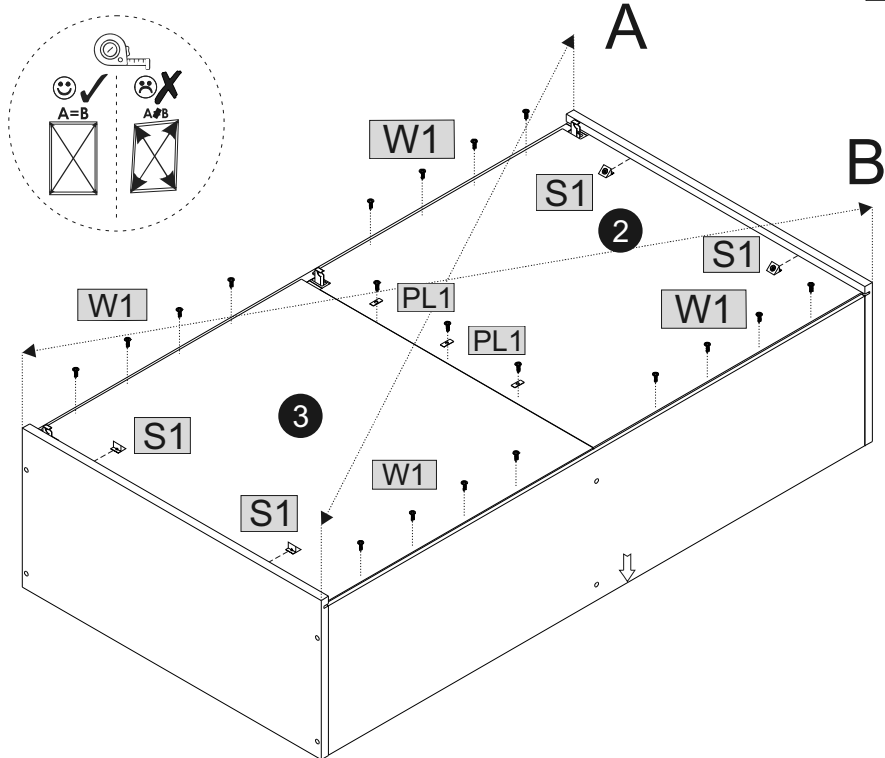

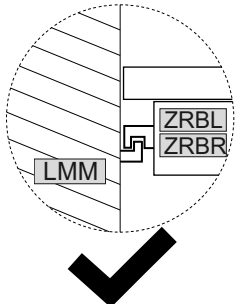
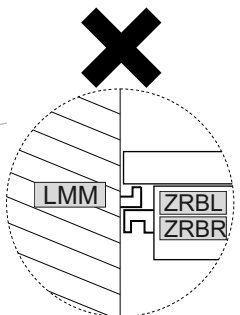
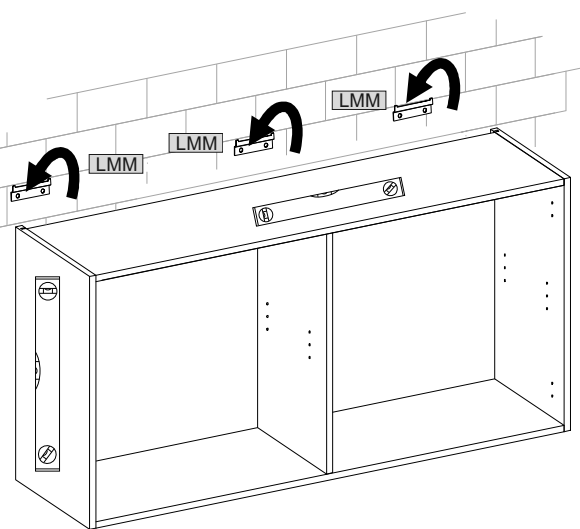
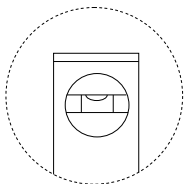
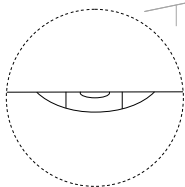
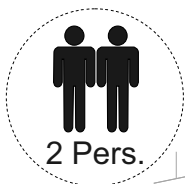
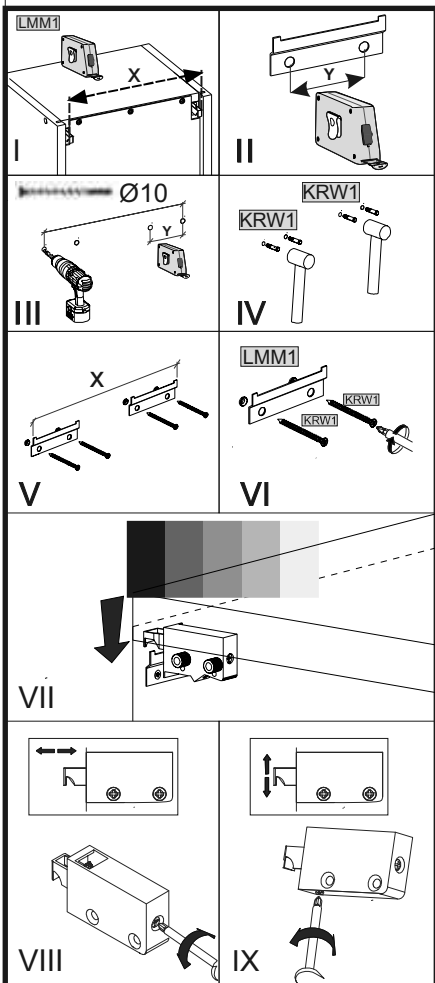

07

			10x50		6x50
LMM1	3	KRW1	6	KRL1	6



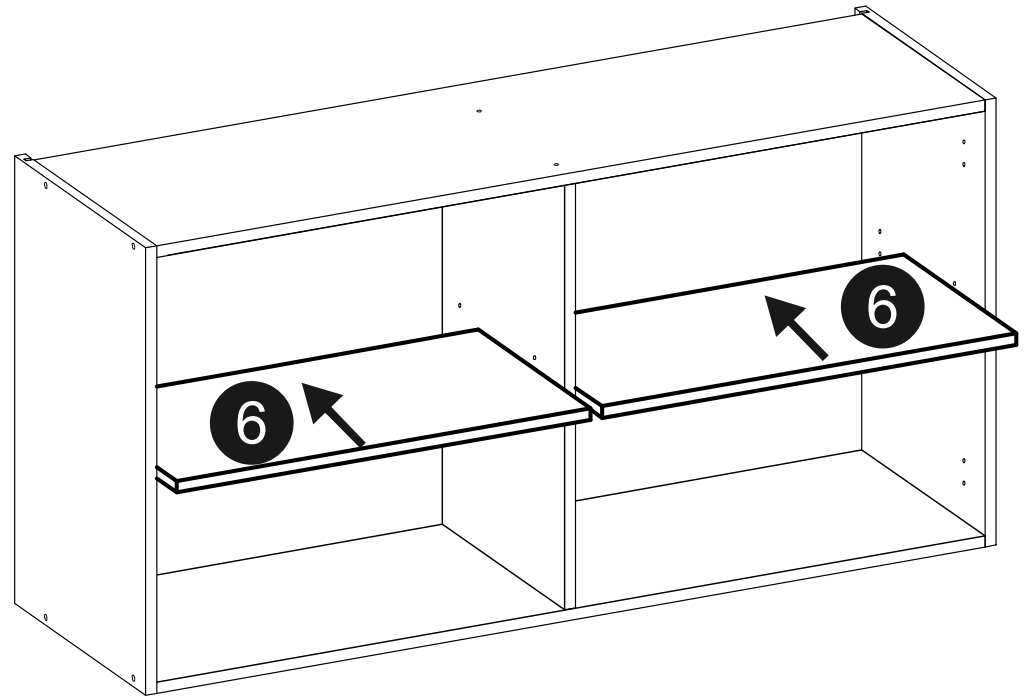
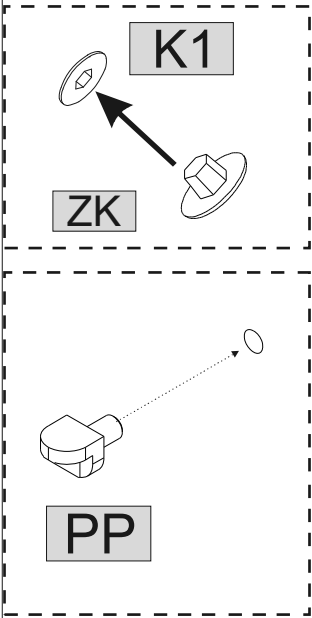

08

			
PP	8	ZK	12

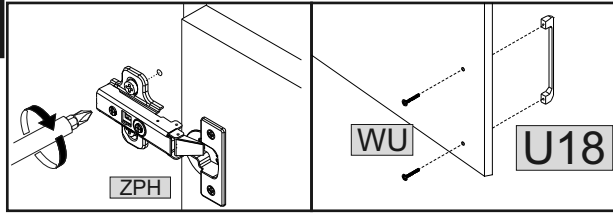

09

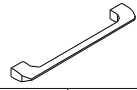

			
WU	4	U18	2

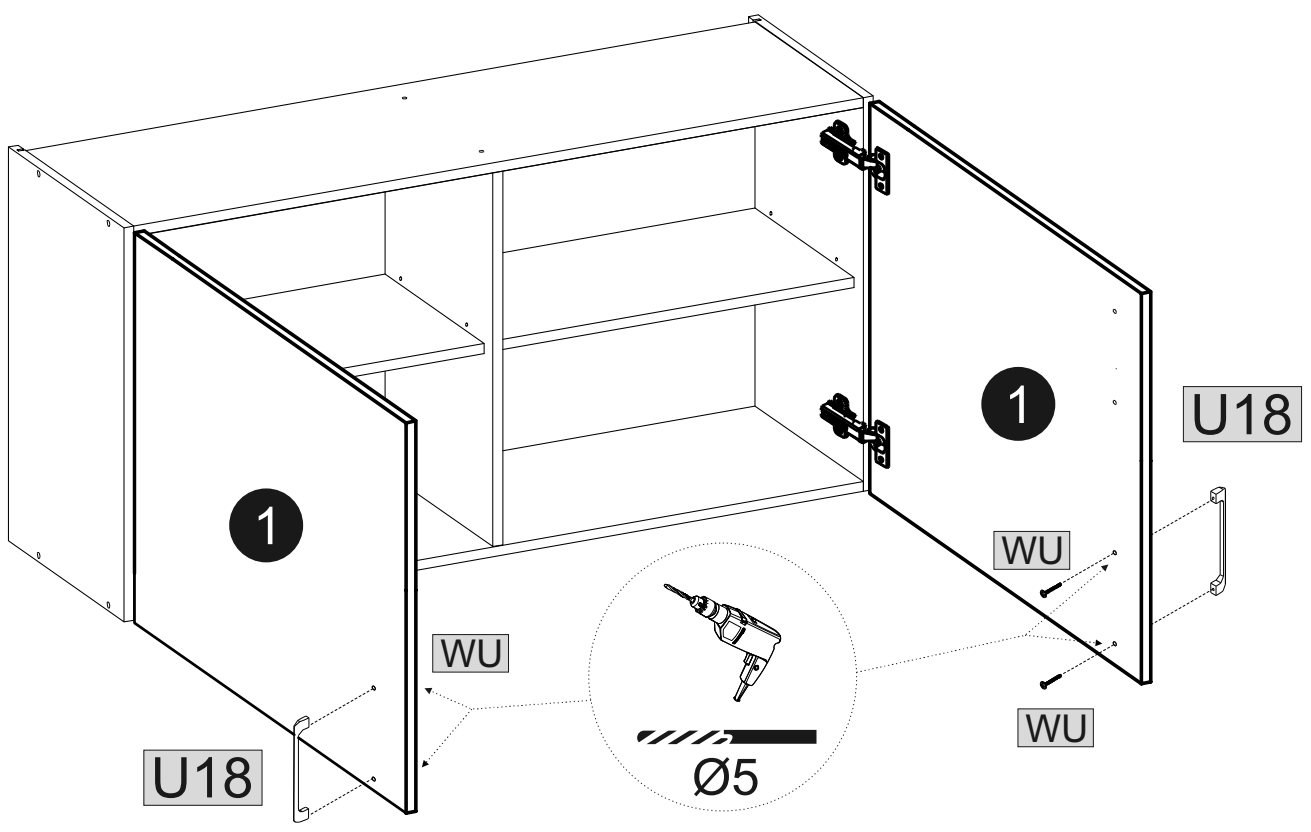

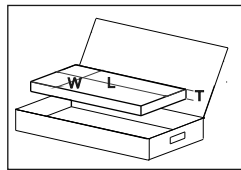
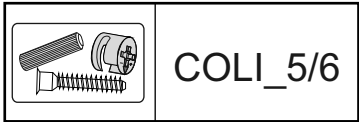
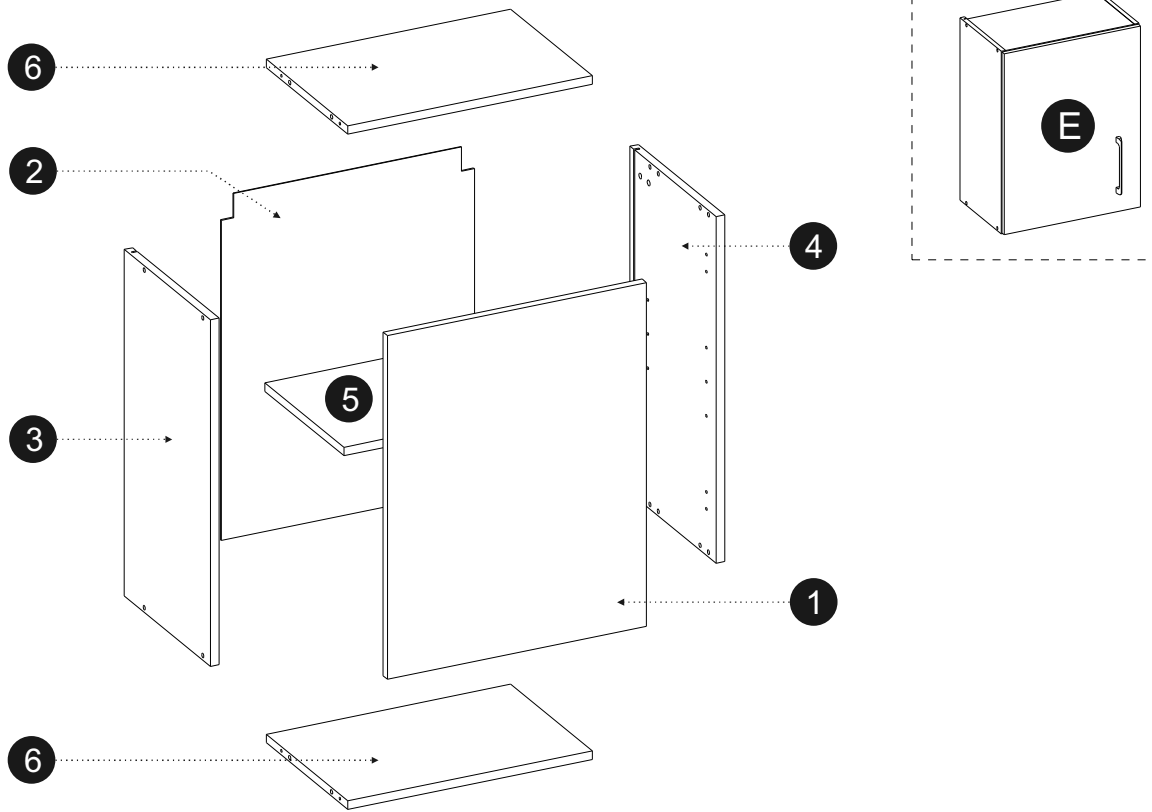

N	L [mm]	W [mm]	T [mm]	Q	COLLI
1	645	496	16	1	COLLI_5/6
2	646	485	3	1	COLLI_5/6
3	650	330	16	1	COLLI_5/6
4	650	330	16	1	COLLI_5/6
5	468	245	16	1	COLLI_5/6
6	468	312	16	2	COLLI_5/6

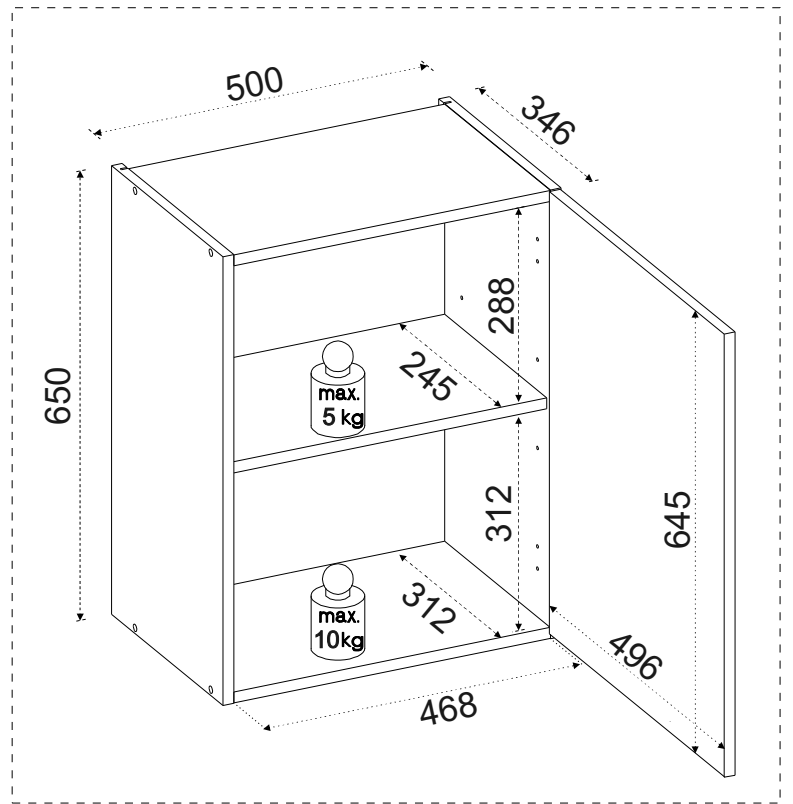

WU 2	W7 4	W4 4	W1 8	U18 1	KRL1 4	KRW1 4	KT1 8	ZK 8
K3 8	ZPH 2	ZRBL 1	ZRBR 1	S1 4	PP 4	LMM 2	KK1 1	

01

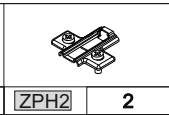
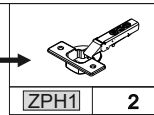
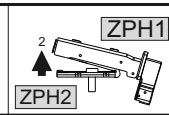
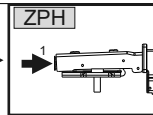
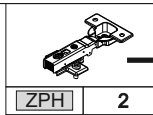
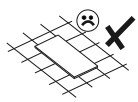
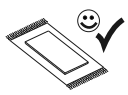

ZPH 2

ZPH1

ZPH2

ZPH1 2

ZPH2 2

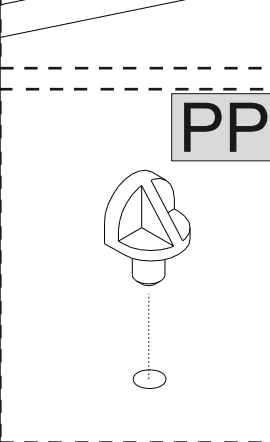
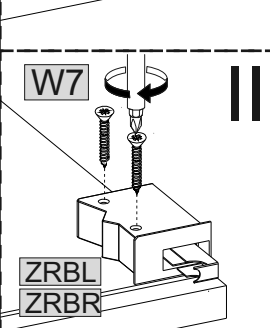
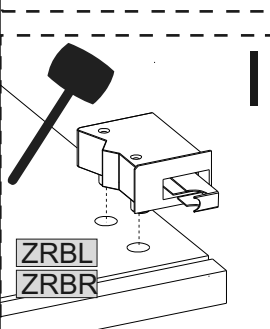
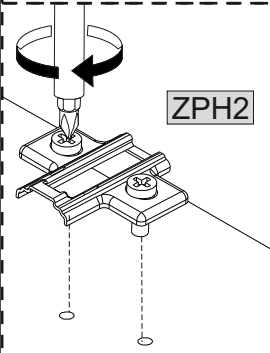
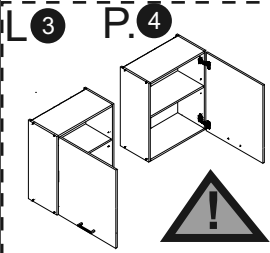

	4x30		
W7	4	PP	4
ZRBR	1	ZRBL	1

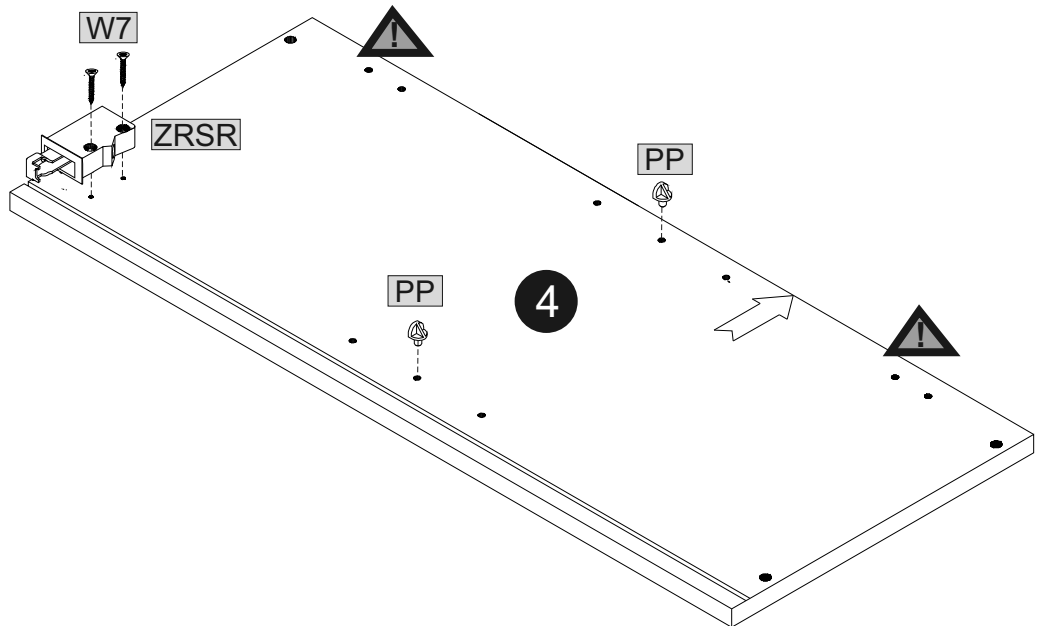
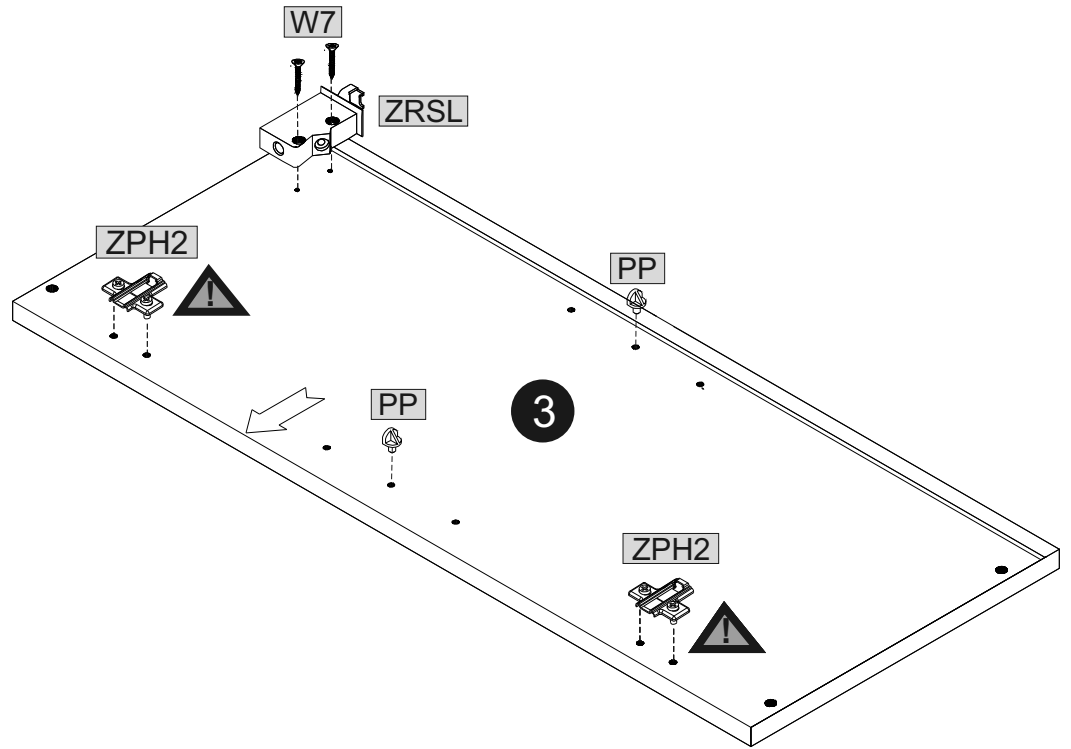

02

X2

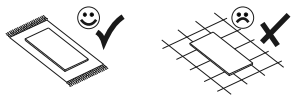

Ø8x40

KT1

4

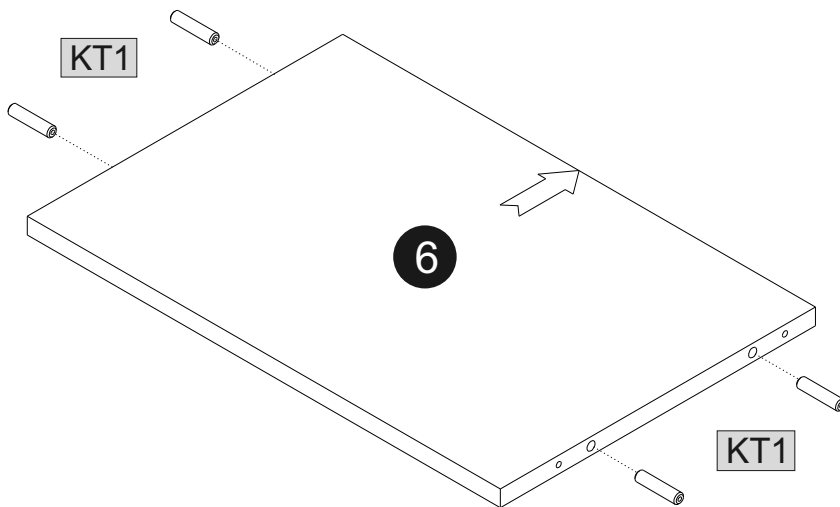

03

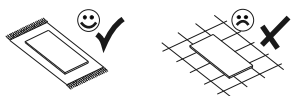

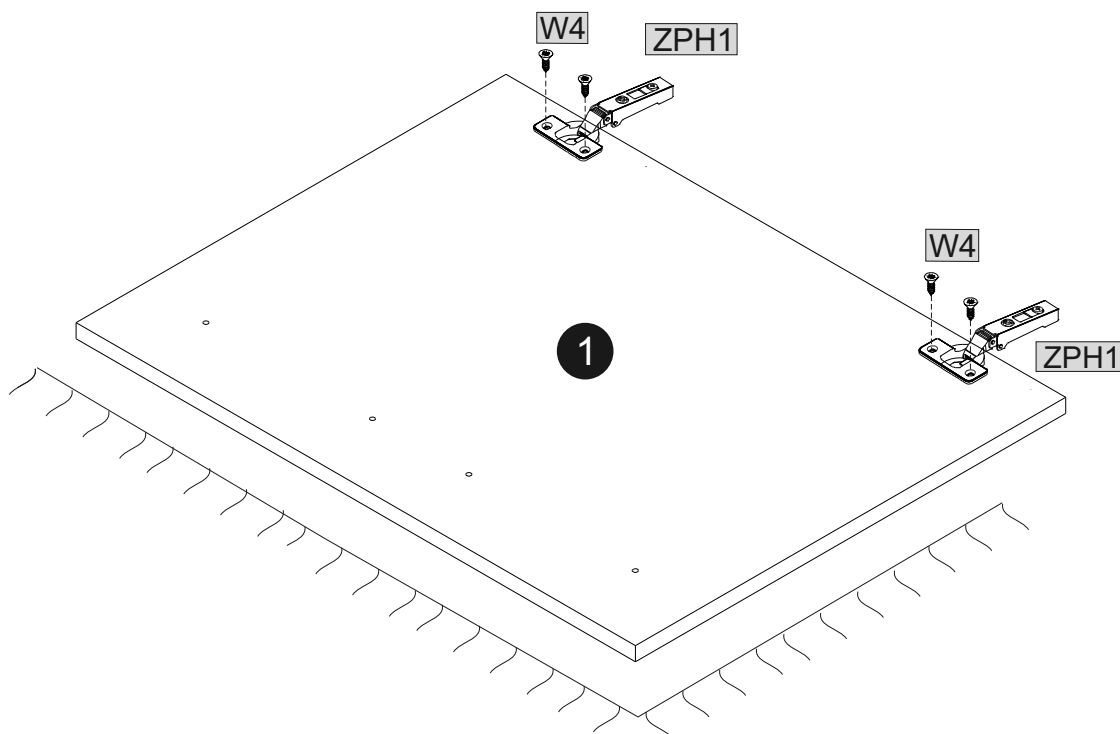
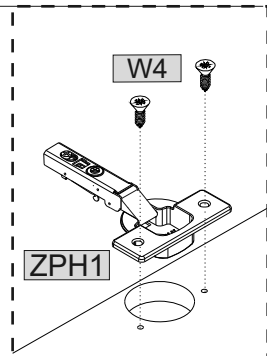

	2		4x13	4
ZPH1	2	W4		4

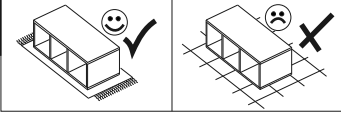

	4		1		2		4		4
ZPH1	4	ZPH1		ZPH1		ZPH1	4	ZPH2	4

04

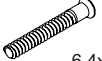

			6,4x50
KK1	1	K3	4

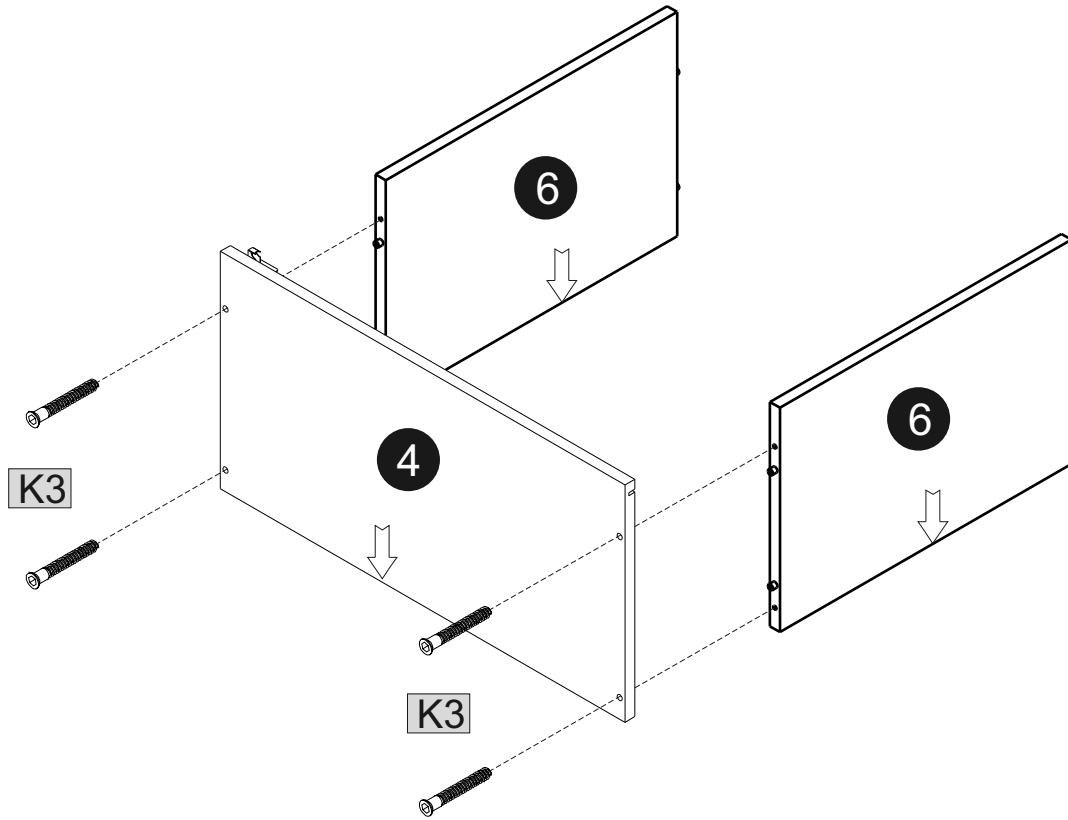

05

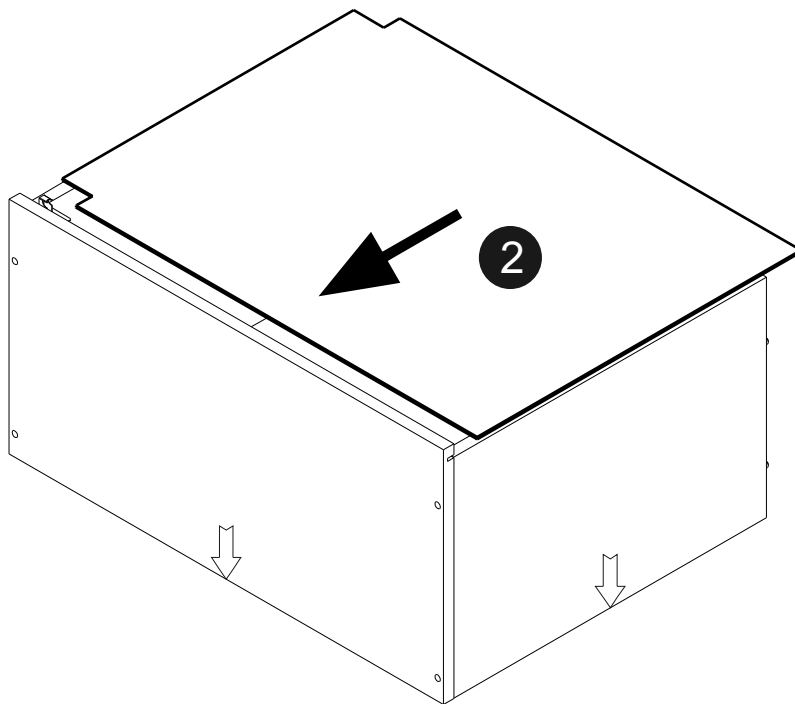
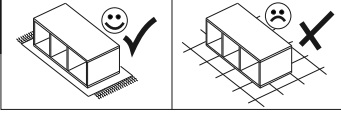

06

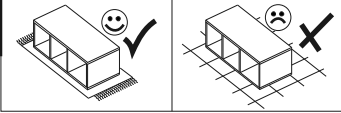

	1		4
KK1		K3	

6,4x50

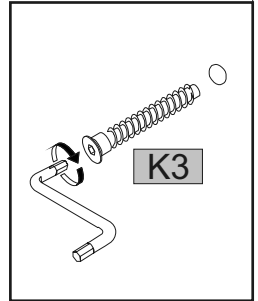
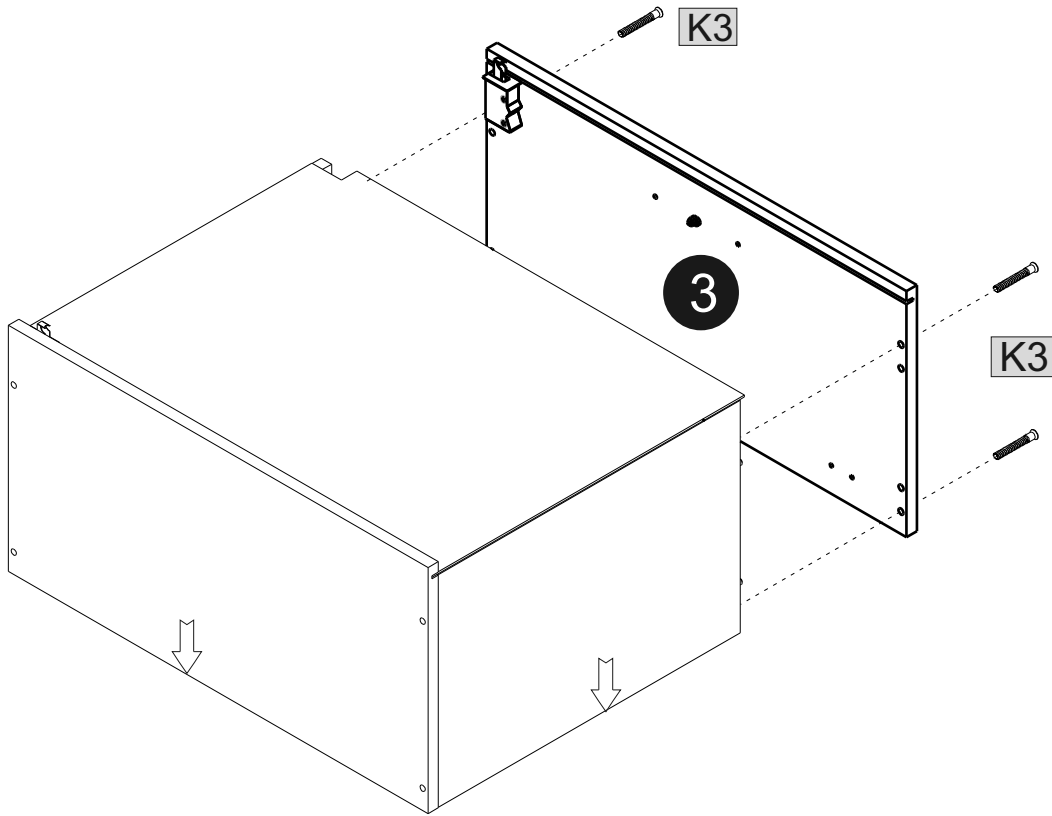

07

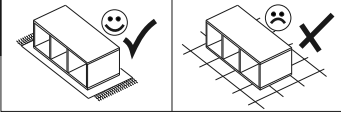

	4		8
S1		W1	

3x16

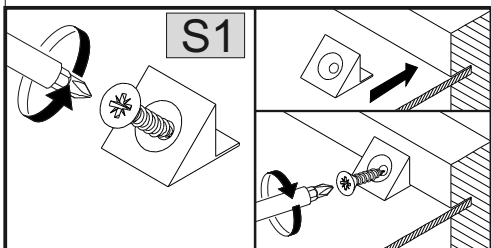
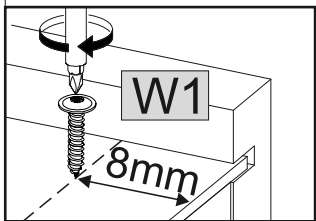
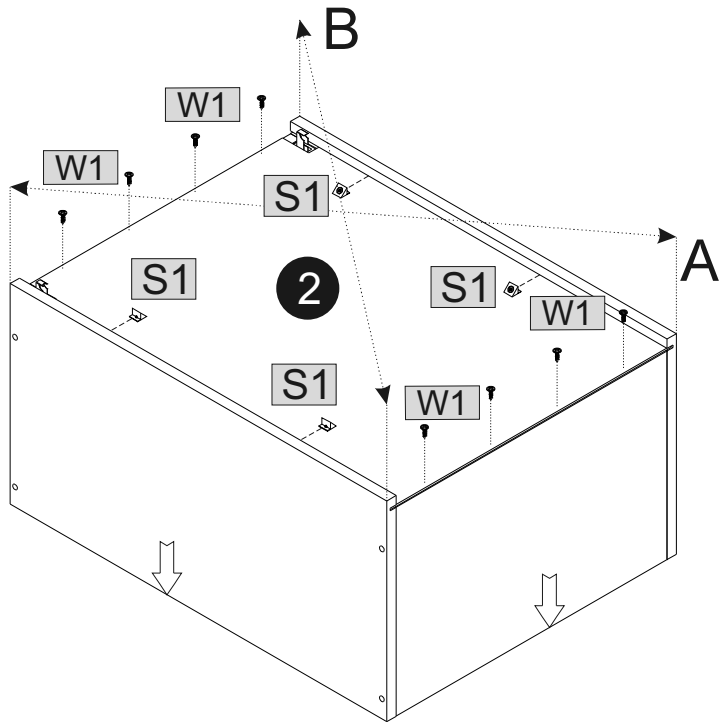
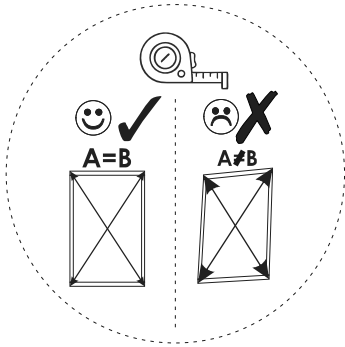

08

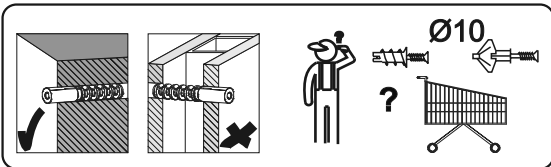

LMM	2	4
	10x50	6x50
	KRW1	KRL1
	4	4

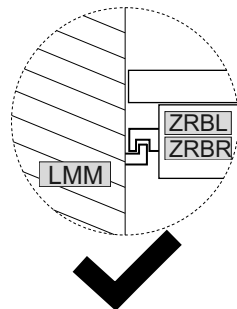
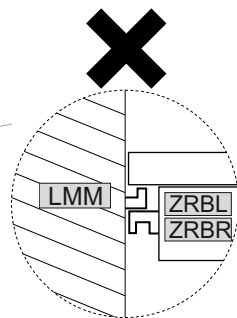
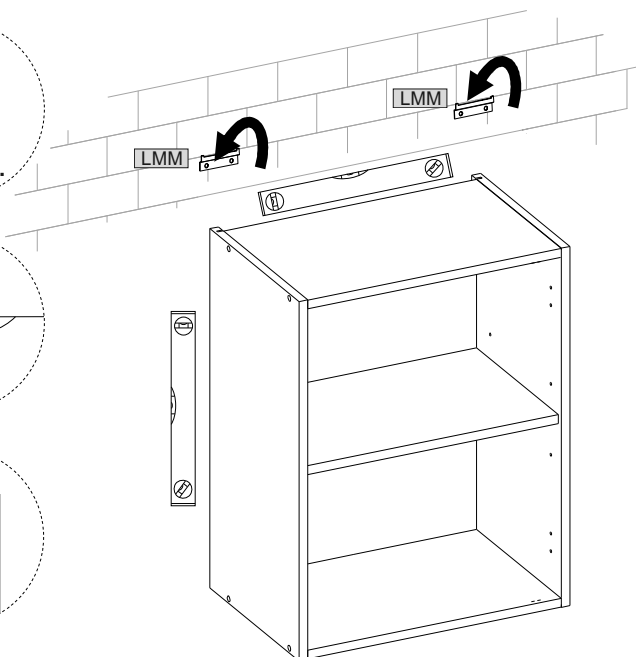
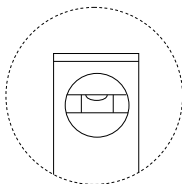
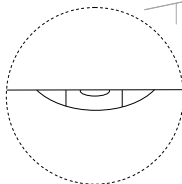
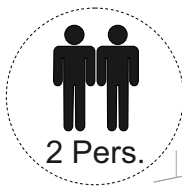
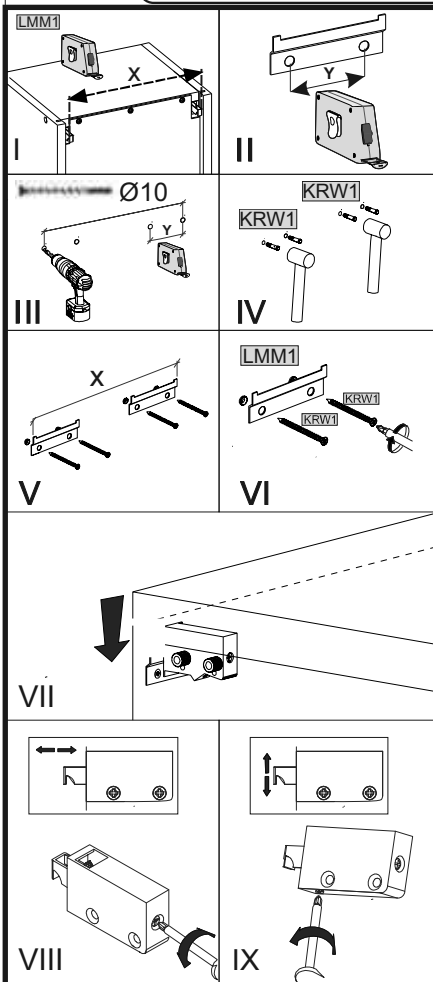

09

ZK	8	2
	U18	3,5x25
	1	WU

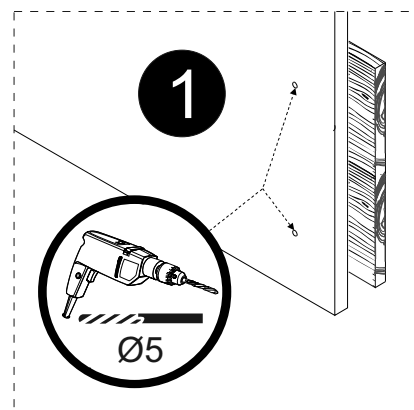
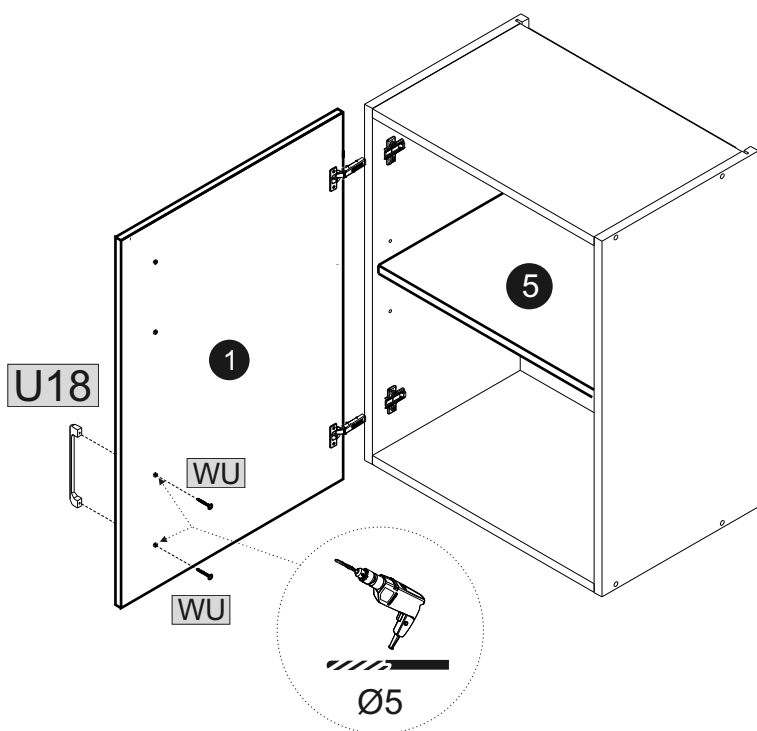
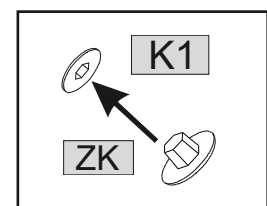
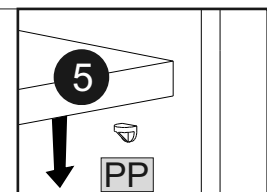

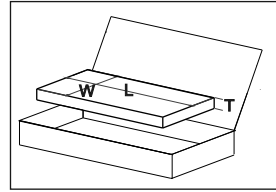
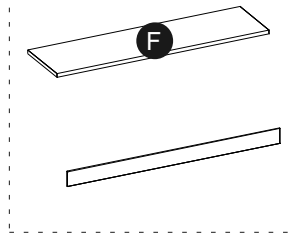
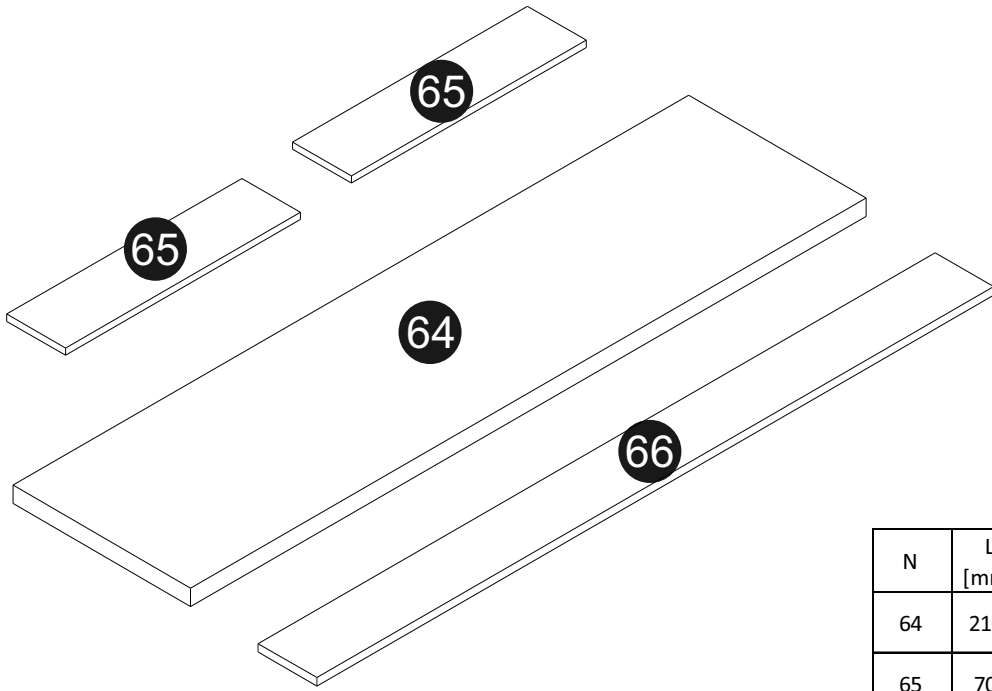

N	L [mm]	W [mm]	T [mm]	Q	COLLI
64	2100	600	38	1	COLLI_6/6
65	704	150	16	2	COLLI_6/6
66	2100	150	16	1	COLLI_6/6

01

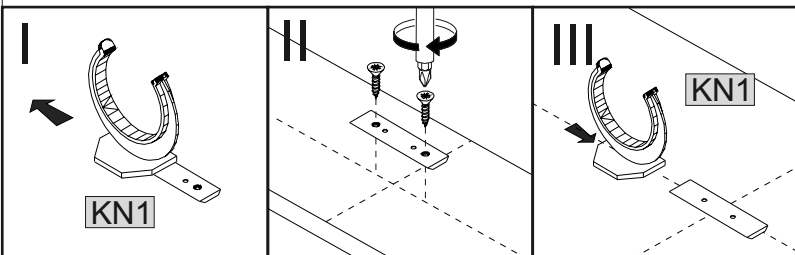
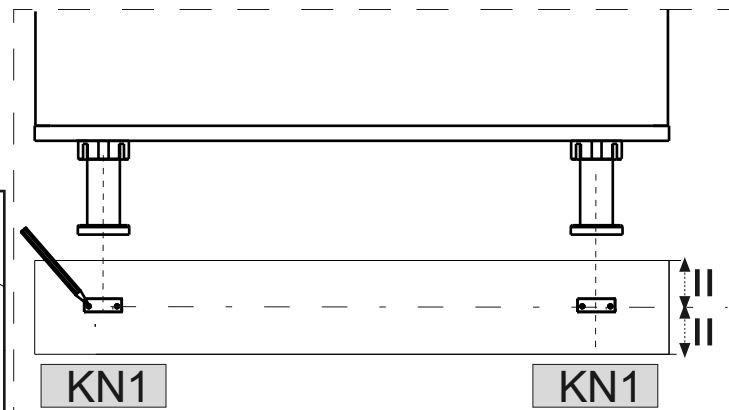
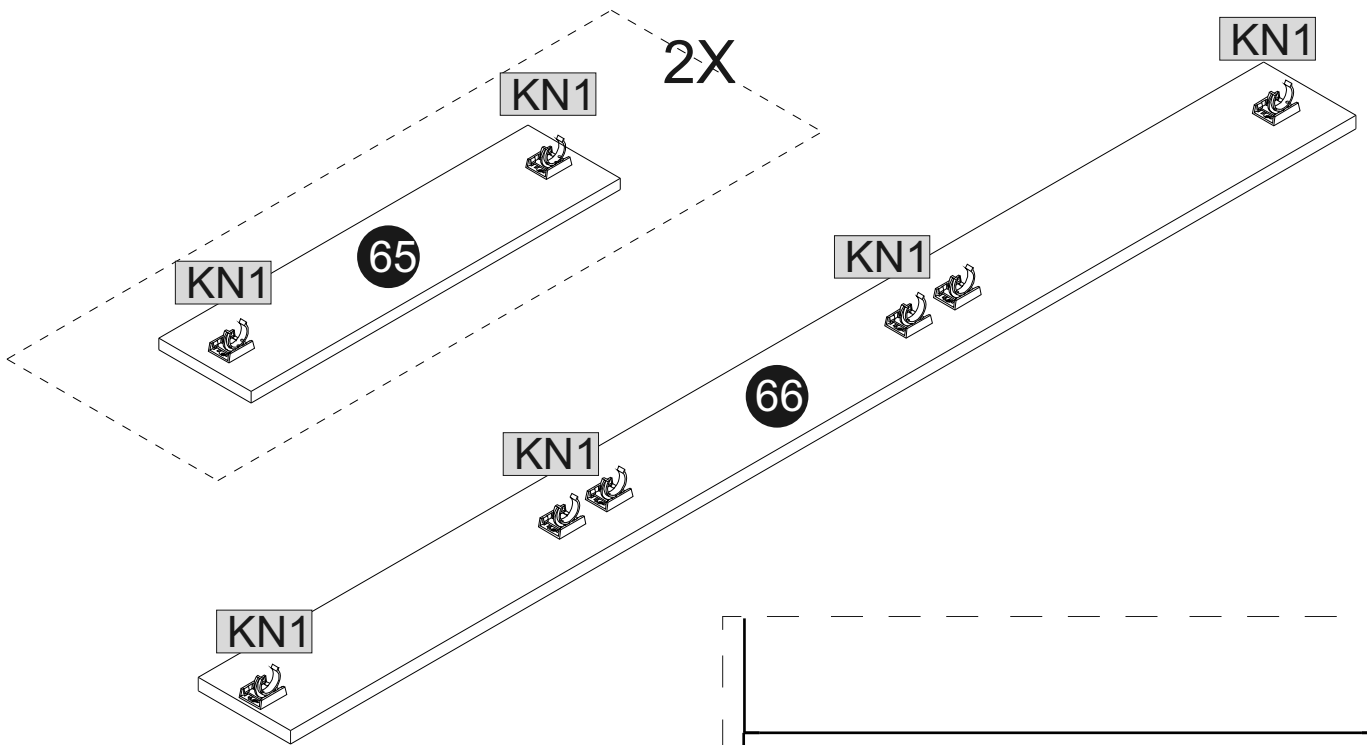
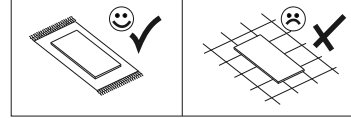

01

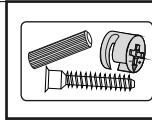
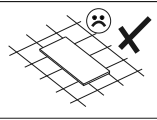
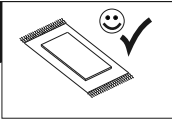

A

B

C

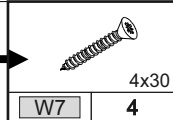

4x30

W7

4



4x25

W14

8

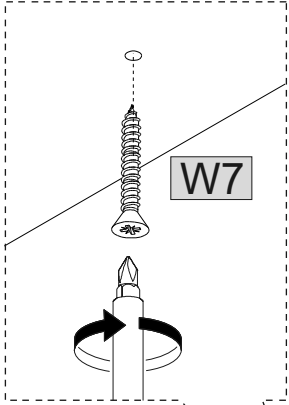

W7

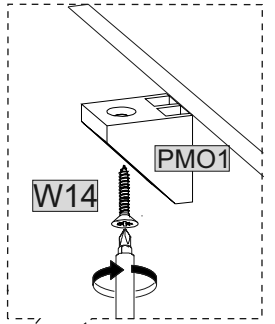

W14

PMO1

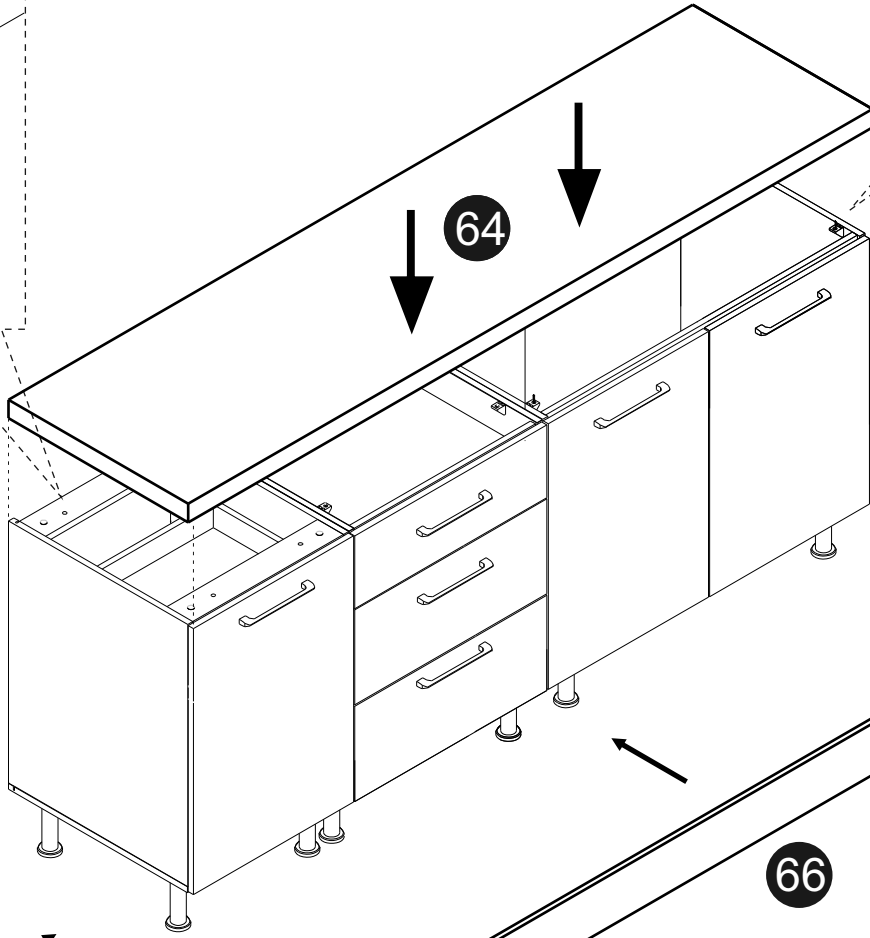

64

65

66

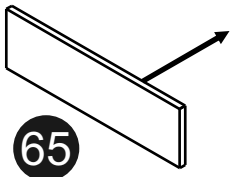

65

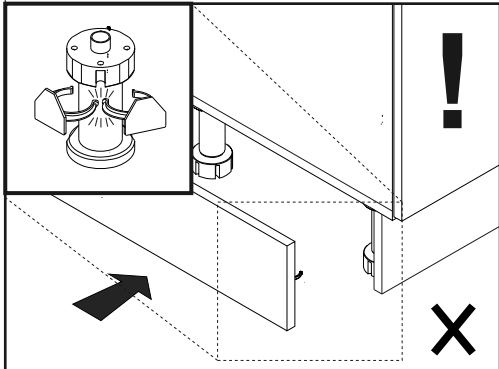

!

X

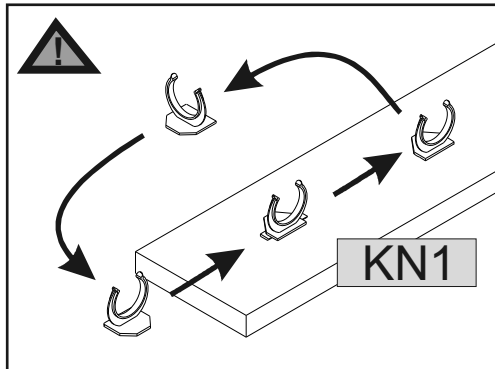

KN1

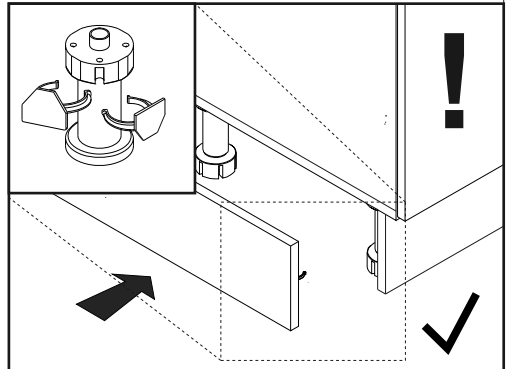

!

✓

Allgemeine Hinweise

Die Montage einer Einbauküche sollte von entsprechend geschulten Fachkräften durchgeführt werden. Vor der Montage müssen die Montagehinweise gelesen werden.

Spezielle, weiterführende Montageanleitungen und Hinweise liegen den Geräten, Spülen, Beleuchtungen und Sonderausstattungen bei und müssen zusätzlich beachtet werden.

Für die Befestigung von Wandhängeelemente gilt:

Wir legen kein Befestigungsmaterial bei. Bitte prüfen Sie die gegebene Wandbeschaffenheit und wenden Sie sich an den örtlichen Fachhandel zum Erwerb der passenden Dübel / Haken / Aufhängeschienen / Schrauben

Für die Aufhängung können entweder Haken oder Aufhängeschienen verwendet werden.

Die Hängeschränke können bei korrekter Montage mit ca. 40 kg belastet werden. Achten Sie auf eine gleichmäßige Lastverteilung

Bei Nichtbeachtung der Montagehinweise können wir entstandene Schäden keine Haftung übernehmen

Achten Sie darauf bei Einzelschränken, oder der gesamten Küchenzeile eine Kippsicherung anzubringen

Sanitär- und Elektroinstallationen dürfen nur von einer entsprechenden Fachkraft vorgenommen werden

Vor Bohrarbeiten muss geprüft werden, dass an der Stelle des Bohrens keine Leitungen für Gas, Wasser, Strom, Heizun
Abflüsse verlegt wurden

Es dürfen keine verändernden Manipulationen am Zubehör oder an Elektrogeräten vorgenommen werden. Dies gilt insbesondere für Befestigungsbohrungen.

Überprüfen Sie vor der Montage ob alle Anschlüsse vorhanden sind und fachgerecht ausgeführt wurden

Die Küche beinhaltet verschluckbare Kleinteile. Kinder unter 3 Jahre nicht ohne Beaufsichtigung lassen

Empfohlenes Vorgehen bei der Küchenmontage:

Planen Sie den genauen Montageort unter Berücksichtigung Ihrer Sanitär- und Elektroanschlüsse

Prüfen Sie ob Ihr Kühl- Gefriergerät Lüftungsauslässe im Sockelbereich bzw. im Bereich der Arbeitsplatte benötigt

Erwerben Sie ggf. passende Lüftungsgitter im Fachhandel und schneiden Sie den Sockel bzw. die Arbeitsplatten gemäß den Anweisungen des Geräteherstellers aus.

Legen Sie fest, ob Sie die Türen mit Rechts- oder Linksanschlag montieren wollen

Montieren Sie zunächst die Unterschränke und richten Sie diese mit einer Wasserwaage aus.

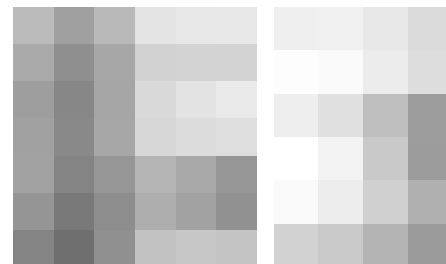
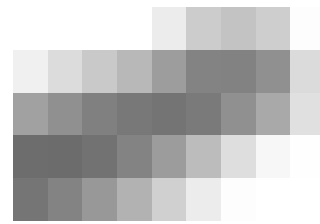

Erst wenn alles exakt steht, verbinden Sie die einzelnen Schränke mit Schrauben. Damit dabei nichts verrutscht, empfehlen wir Ihnen dringend den Einsatz von zwei Schraubzwingen. Die Schrankoberflächen schützen Sie mit Zulagehölzern vor Eindrücken.

Ermitteln Sie durch exaktes Messen die Positionen der Bohrungen für die Hängebeschläge

Legen Sie die Arbeitsplatte auf die Korpusse, richten Sie sie aus, und fixieren Sie sie mit Zwingen. markieren Sie die Lage und -breite des Herdunterschrankes.

Auf der Unterseite der Arbeitsplatte reißen Sie im markierten Bereich den Herdplattenausschnitt auf. Mitteln Sie sie aus, so dass die Spüle mittig im Unterschrank sitzt und vorne und hinten die Plattenrestbreite gleich wird.

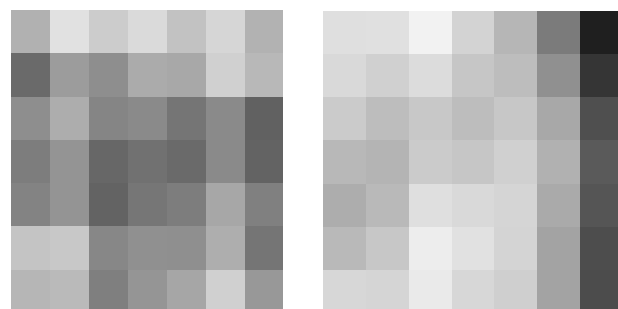

Empfohlenes Vorgehen bei der Küchenmontage:

Bohren Sie in den vier Ecken jeweils ein 10-mm-Loch zum leichteren Einsetzen der Stichsäge, und schneiden Sie den Herdausschnitt entlang Ihrer Risse aus. Arbeiten Sie immer von der Plattenunterseite, damit die Plattenoberfläche durch die Stichsäge nicht ausfasert. Schalten Sie dazu auch den Pendelhub an Ihrer Stichsäge, sofern vorhanden, aus.

Zum Schutz der Holzteile können Sie rundum die Sockelteile eine Silikonnaht ziehen

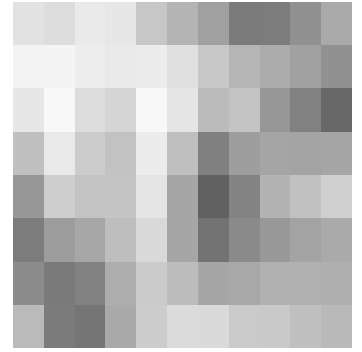

Empfohlenes Vorgehen bei der Küchenmontage:

Bohren Sie in den vier Ecken jeweils ein 10-mm-Loch zum leichteren Einsetzen der Stichsäge, und schneiden Sie den Herdausschnitt entlang Ihrer Risse aus. Arbeiten Sie immer von der Plattenunterseite, damit die Plattenoberfläche durch die Stichsäge nicht ausfasert. Schalten Sie dazu auch den Pendelhub an Ihrer Stichsäge, sofern vorhanden, aus.

Zum Schutz der Holzteile können Sie rundum die Sockelteile eine Silikonnaht ziehen

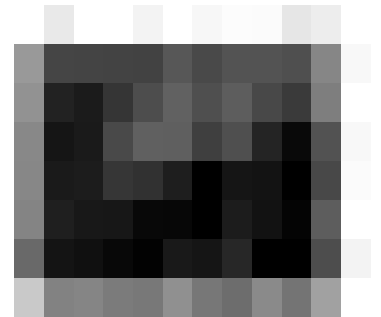

DE	<p>Warnhinweis: Wenn der Ware Dübel und Schrauben beiliegen, sind sie ausschließlich zur Anwendung an Wänden aus massiven und einheitlichen Materialien bestimmt, um ein Umkippen zu verhindern. Vergewissern Sie sich vor dem Bohren, dass sich keine Gas-, Wasser-, oder Stromleitungen an der Bohrstelle befinden. Zur Befestigung an anderen Wänden müssen Spezialdübel verwendet werden. Erkundigen Sie sich im Handel nach den für die jeweilige Wandbeschaffenheit geeigneten Schrauben und oder Dübel. Für eine unsachgemäße Montage und dadurch entstandene Schäden übernimmt der Hersteller keine Haftung. Bitte alle Schrauben in regelmäßigen Abständen überprüfen und nachziehen.</p>
FR	<p>Avertissement : Pour éviter le basculement accidentel du meuble, la fixation du meuble au mu rest obligatoire. Si des chevilles et des vis sont fournies avec l'article, elles sont exclusivement destinées à être utilisées sur des murs en matériaux massifs et homogènes pour éviter tout basculement. Avant de percer, assurez-vous qu'aucune conduite de gaz, d'eau ou d'électricité ne se trouve à l'endroit où vous percez. Pour la fixation sur d'autres murs, il faut utiliser des chevilles spéciales. Renseignez-vous en magasin sur les vis et les chevilles adaptées à chaque type de mur. Le fabricant décline toute responsabilité en cas de montage incorrect et de dommages qui en résulteraient. Veuillez vérifier et resserrer toutes les vis à intervalles réguliers. ATTENTION ! Les meubles contenant des panneaux à base de bois (panneaux de particules, panneaux de fibres, contreplaqué...) peuvent émettre des substances polluantes dans l'air intérieur. Il est ainsi recommandé, après l'installation du meuble dans son logement, d'aérer fréquemment la pièce concernée pendant au moins quatre semaines afin de réduire son exposition aux polluants émis par le meuble LED: Ce luminaire est un produit de décoration. Ce luminaire ne convient pas pour l'éclairage principal d'une pièce de la maison.</p>
UK	<p>Warning: If dowels and screws are included with the product, they are only intended for use on walls made of solid and uniform materials to prevent them from tipping over. Before drilling, make sure that there are no gas, water or electricity pipes at the drilling site. Special anchors must be used for fastening to other walls. Ask in the trade for the screws and or dowels suitable for the respective wall condition. The manufacturer accepts no liability for improper installation and any resulting damage. Please check and retighten all screws at regular intervals.</p>
IT	<p>Avvertenza: Se con il prodotto sono forniti tasselli e viti, questi sono destinati esclusivamente all'utilizzo su pareti realizzate con materiali solidi ed uniformi, per evitare il ribaltamento. Prima di eseguire i fori assicurarsi che non ci siano condutture di gas, acqua o elettriche vicino al punto di perforazione. Per il fissaggio ad altre pareti è necessario utilizzare tasselli speciali. Chiedere al proprio rivenditore le viti e/o tasselli adatti al tipo di parete in questione. Il produttore non si assume alcuna responsabilità in caso di montaggio improprio e dei danni che ne derivano. Controllare e serrare tutte le viti a distanza regolare.</p>
PL	<p>Ostrzeżenie: Jeżeli do towaru dołączone są kołki i śruby, są one przeznaczone wyłącznie do stosowania na ścianach wykonanych z solidnych i jednolitych materiałów, aby zapobiec przewróceniu. Przed rozpoczęciem wiercenia należy upewnić się, że w miejscu wiercenia nie są ułożone rury gazowe, wodociągowe lub przewody elektryczne. Do mocowania do innych ścian należy stosować kołki specjalne. O śruby lub kołki odpowiednie dla konstrukcji danej ściany należy pytać w sklepach specjalistycznych. Producent nie ponosi odpowiedzialności za nieprawidłowy montaż i wyniki z tego tytułu szkody. Wszystkie śruby należy regularnie sprawdzać i dokręcać.</p>
ESP	<p>Advertencia: En el caso de incluirse tacos y tornillos con la mercancía, estos están previstos únicamente para su uso en paredes macizas y homogéneas a fin de evitar un posible vuelco. Antes de taladrar, asegúrese de que por el punto de perforación no pasan tuberías de gas o agua o cables eléctricos. Para la fijación en otro tipo de paredes deben utilizarse tacos especiales. Pregunte en la tienda por los tornillos o tacos adecuados para las características de la pared en cuestión. El fabricante no asume ninguna responsabilidad por un montaje incorrecto ni por los daños resultantes del mismo. Compruebe todos los tornillos en intervalos regulares y apriételes.</p>
CZ	<p>Výstražné upozornění: Pokud jsou k výrobku přiloženy hmoždinky a šrouby, jsou určeny výhradně pro použití do stěn zhotovených z masivních a homogenních materiálů, a to za účelem zajištění proti převrácení. Před vrtáním se ujistěte, že se v místě vrtání nenachází vedení plynu, vody nebo elektriny. Pro připevnění k jiným stěnám je nutné použít speciální hmoždinky. Informujte se v obchodě o hmoždinkách a/nebo šroubech vhodných pro příslušnou strukturu stěny. Výrobce nenese odpovědnost za nesprávnou montáž a za škody jí způsobené. Všechny šrouby pravidelně kontrolujte a dotahujte.</p>
SK	<p>Informácia o nebezpečenstve: Ak sú k tovaru priložené príchytky a skrutky, sú určené výlučne na použitie na stenách z masívnych a jednotných materiálov, aby sa zabránilo prevráteniu. Pred vrtaním sa uistite, že sa na vrtanom mieste nenachádzajú žiadne plynové, vodovodné alebo elektrické vedenia. Na upevnenie na iných stenách musia byť použité špeciálne príchytky. Spýtajte sa v predajni na skrutky a/alebo príchytky vhodné pre príslušný typ steny. Výrobca nepreberá ručenie za nesprávnu montáž a tým vzniknuté škody. Všetky skrutky v pravidelných intervaloch kontrolujte a dotiahnite.</p>
HU	<p>Figyelmeztetés: Amennyiben a termék csomagolásá tipliket és csavarokat is tartalmaz, azok kizárólag masszív, egységes anyagból készült falakon használhatók, a felborulás megakadályozásának céljából. A fúrás előtt bizonyosodjon meg arról, hogy a fúrás helyén nem található gáz-, víz- vagy elektromos vezeték. Egyéb falakra történő rögzítéshez speciális tiplik szükségesek. Az egyes faltípusokkal használható megfelelő csavarokkal és/vagy tiplikkel kapcsolatos információkért kérjük, forduljon forgalmazójához. A nem szakszerű szerelésért és az abból keletkező károkért a gyártót semmilyen felelősség nem terheli. Minden csavart ellenőrizzen és rögzítsen rendszeresen.</p>
BG	<p>Предупредително указание: Ако в окомплектовката на доставката на стоката са включени дюбели и винтове, те са предназначени единствено за употреба върху стени от масивни и еднородни материали, за да се предотврати преобръщане. Преди пробиване се уверете, че на мястото на пробиване няма тръби за газ, за вода или електрически проводници. За закрепване към други стени трябва да се използват специални дюбели. Информирайте се в търговската мрежа относно подходящите винтове и/или дюбели за съответната конструкция на стената. Производителят не поема отговорност за неправилен монтаж и възникнали в резултат на това щети. Моля, проверявайте и затягвайте всички винтове на редовни интервали.</p>
TR	<p>Uyarı: Ürün paketinde dübel ve vida varsa, bunlar devrilmeyi önlemek amacıyla, sadece masif ve yekpare malzemelerden imal edilmiş duvarlardaki kullanımlar için öngörülmüştür. Matkapla delik açmadan önce delme noktasında gaz, su veya elektrik hatlarının olmadığından emin olun. Ürünü başka duvarlara sabitlemek için özel dübeller kullanılmalıdır. Piyasadaki satıcılardan ilgili duvarın özelliğine uygun vidalar ve dübeller hakkında bilgi alın. Usulüne aykırı bir montaj ve bu nedenle oluşmuş hasarlar için üretici sorumluluk almamaktadır. Lütfen tüm vidaları düzenli aralıklarla kontrol edip tekrar sıkın.</p>

PT	Advertência: Caso o produto venha com buchas e parafusos incluídos, os mesmos são exclusivamente destinados à fixação em paredes de materiais sólidos e uniformes, para evitar que o produto tombe. Antes de iniciar a perfuração, certifique-se de que não existem canalizações de gás, água ou fios elétricos a passar no local dos furos. Para a fixação nouro tipo de paredes, têm de ser utilizadas buchas especiais. Informe-se junto de um comerciante especializado sobre os parafusos e buchas a utilizar na parede específica. O fabricante não assume qualquer responsabilidade no caso de uma montagem inadequada e qualquer dano daí resultante. Verifique e volte a apertar todos os parafusos regularmente.
SI	Opozorilo: če so blagu priloženi zidni vložki in vijaki, so ti namenjeni izključno za uporabo na stenah iz masivnih in enotnih materialov, da se prepreči prevrnitev. Pred vrtnjem se prepričajte, da na mestu vrtnja ni plinskih, vodnih ali električnih napeljav. Za pritrditev na druge stene je treba uporabljati posebne zidne vložke. Pozanimajte se v trgovini o vijakih in/ali zidnih vložkih, primernih za posamezno sestavo stene. Proizvajalec ne prevzema jamstva za nepravilno montažo in zaradi tega nastalo škodo. Vse vijake redno preverjajte in naknadno privijajte.
NL	Waarschuwing: Indien er bij het product pluggen en schroeven zijn meegeleverd, zijn deze uitsluitend bestemd om in muren van massieve en homogene materialen te gebruiken om te voorkomen dat het product kantelt. Controleer voordat u begint of er geen gas-, water- of elektriciteitsleidingen lopen waar u gaat boren. Voor de bevestiging aan andere soorten muren moeten speciale pluggen worden gebruikt. Informeer in de winkel welke schroeven en/of pluggen geschikt zijn voor de desbetreffende muur. De fabrikant is niet aansprakelijk voor een onjuiste montage en de daardoor ontstane schade. Controleer regelmatig of alle schroeven nog goed vastzitten en draai ze zo nodig vast.
SRB	Upozoravajuća napomena: Ako su uz robu priloženi tiplovi i zavrtaji, isti su namenjeni isključivo za primenu na zidovima od kompaktnih i homogenih materijala, kako bi se sprečilo prevrtanje. Pre bušenja se uverite da se na mestu bušenja ne nalaze vodovi za gas, vodu ili struju. Za fiksiranje na drugačijim zidovima moraju da se upotrebe specijalni tiplovi. Raspitajte se u trgovini o zavrtjima i/ili tiplovima koji su adekvatni za dotičnu teksturu zida. Proizvođač ne preuzima nikakvu odgovornost za nestručnu montažu i štete koje su nastale na taj način. Sve zavrtnje kontrolišite i dotežite u redovnim intervalima.
RO	Indicație de avertizare: Dacă produsul este livrat împreună cu șuruburi și dibluri, acestea sunt destinate exclusiv utilizării pe pereții construiți din materiale masive și uniforme, pentru a preveni răsturnarea produsului. Înainte de a realiza găurile, asigurați-vă că nu există conducte de gaz, apă sau electricitate în locul pe care doriți să-l găuriți. Pentru prinderea pe alte tipuri de pereți, trebuie să utilizați dibluri speciale. Interesați-vă la magazinul specializat, pentru a găsi șuruburile și/sau diblurile potrivite pentru peretele dvs. Producătorul nu este responsabil, în cazul unui montaj necorespunzător pentru daunele rezultate. Vă rugăm să verificați toate șuruburile la intervale regulate și să le strângeți.
HR	Upozorenje: Ako su uz proizvod priložene tiple i vijci, oni su namijenjeni isključivo za korištenje na zidovima od čvrstih i jednoličnih materijala kako bi se spriječilo prevrtanje. Prije bušenja provjerite da na mjestu bušenja nema električnih vodova, plinskih ili vodovodnih cijevi. Za pričvršćivanje na ostale zidove potrebno je koristiti posebne tiple. Prilikom kupnje raspitajte se kod svog prodavača o vijcima i tiplama koji su prikladni za odgovarajuću zidnu strukturu. Proizvođač ne odgovara za štete nastale uslijed nepravilne montaže. Sve vijke potrebno je redovito provjeravati i zategnuti.
SE	Varning: Om plugg och skruvar följer med produkten är de endast avsedda för väggar av massivt och enhetligt material för att förhindra att produkten vippar. Försäkra dig om att inga gas-, vatten- eller elledningar befinner sig på platsen som du ska borra innan du börjar. För fastsättning i väggen måste specialplugg användas. Informera dig i en butik om vilka skruvar och plugg som passar till vilken vägg. För en felaktig montering och skador som uppstår på grund av detta tar tillverkaren inget ansvar. Kontrollera och dra åt alla skruvar med jämna mellanrum.
RUS	Предупреждение: Если изделие поставляется вместе с дюбелями и шурупам, они предназначены исключительно для использования на стенах из монолитных и однородных материалов, чтобы предотвратить возможное обрушение. Перед началом сверления убедитесь, что на месте сверления нет газопровода, водопровода или электропроводки. Для крепления к другим стенам необходимо использовать специальные дюбели. Узнайте у продавца, какие шурупы или дюбели подходят для соответствующей структуры стены. Производитель не несет ответственности за неправильный монтаж и вызванный им ущерб. Регулярно проверяйте и подтягивайте все шурупы.
UKR	Попередження: Якщо до виробу додаються дюбелі та гвинти, вони призначені виключно для використання на стінах з цільних й однорідних матеріалів, щоб не допустити перекидання. Перед свердлінням переконайтеся, що на місці свердління немає ліній газо-, водопостачання чи електропроводки. Для кріплення до інших стін необхідно використовувати спеціальні дюбелі. Запитайте продавця, які гвинти та/або дюбелі підходять для стіни з відповідною структурою. Виробник не несе відповідальності за неправильний монтаж та збитки, що виникли внаслідок цього. Перевіряйте та підтягуйте всі гвинти через регулярні проміжки часу.
LT	Įspėjimas: jei prie prekės pridėtos mūrvinės ir varžtai, jie skirti naudoti tik ant sienų, pagamintų iš tvirtų ir vienujų medžiagų, kad būtų galima išvengti apvirtimo. Prieš gręždami įsitinkite, kad gręžiamoje vietoje nėra dujotiekio, vandentiekio ar elektros linijų. Tvirtinant prie kito tipo sienų reikia naudoti specialias mūrvinės. Teiraukitės pardavėjo atitinkamai sienos konstrukcijai tinkamų varžtų ir (arba) mūrvinių. Gamintojas neprisiima atsakomybės dėl netinkamo montavimo ir dėl to atsiradusios žalos. Visus varžtus reguliariai tikrinkite ir priveržkite.
LV	Brīdinājums: Ja precei ir pievienoti dībeļi un skrūves, prece ir paredzēta izmantošanai tikai uz sienām, kas izgatavotas no cietiem un viendabīgiem materiāliem, lai novērstu apgāšanos. Pirms urbšanas pārlicinieties, ka urbšanas vietā nav gāzes, ūdens vai elektropārvades līniju. Lai piestiprinātu pie citām sienām, jāizmanto speciāli dībeļi. Jautājiet savam izplatītājam par skrūvēm un/vai dībeļiem, kas ir piemēroti attiecīgajai sienas konstrukcijai. Ražotājs neuzņemas atbildību par nepareizu montāžu un no tās sekojošajiem bojājumiem. Lūdzu, regulāri pārbaudiet un pievelciet visas skrūves.
EE	Hoiatus! Kui tootele on kaasa pandud tüüblid ja kruvid, on need mõeldud kasutamiseks üksnes massiivsest ja ühtsest materjalist seintel, vältimaks ümberkukkumist. Veenduge enne puurimist, et puurimiskohas ei oleks gaasi- või veetorusid ega elektrijuhtmeid. Seintele kinnitamiseks tuleb kasutada spetsiaalseid tüüpleid. Uurige kaubandusvõrgust, millised kruvid ja/või tüüblid konkreetse seina jaoks sobivad. Tootja ei võta endale mittenõuetekohasest paigaldamisest tingitud kahjude eest mingit vastutust. Kontrollige ja järelpingutage kõiki kruvisid regulaarselt.



**LE TRI
+ FACILE**



FR

**Donnez ou recyclez
vos meubles.**



Association



Magasin



Déchèterie

<https://quefairedemesdechets.fr>

TURIN KS 60

73/007/..



„MEBLE-OKMED” DEMKO - SPÓŁKA JAWNA
ul. Kolejowa 13, 14-500 Braniewo, POLSKA
(+48) 55 243 27 26

ZP: .../...

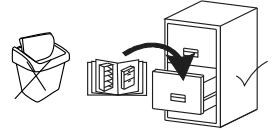

TURIN
KS 60
ZP:/..

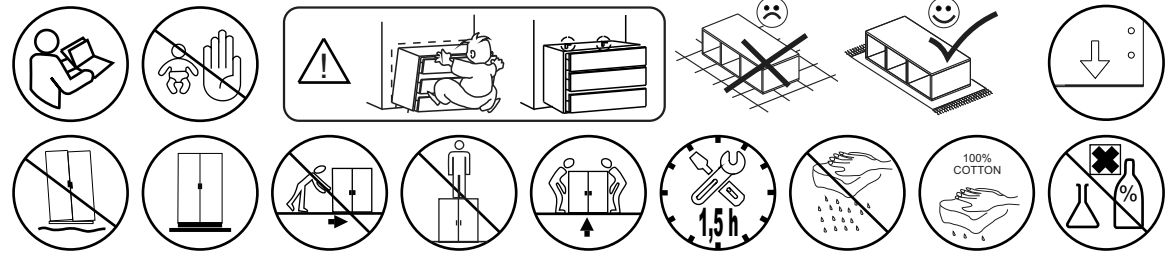
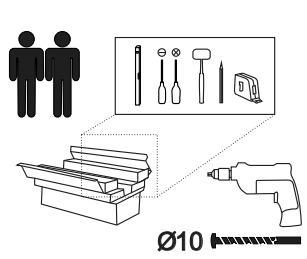
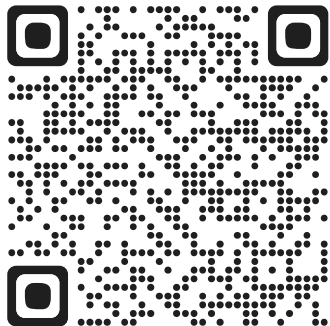
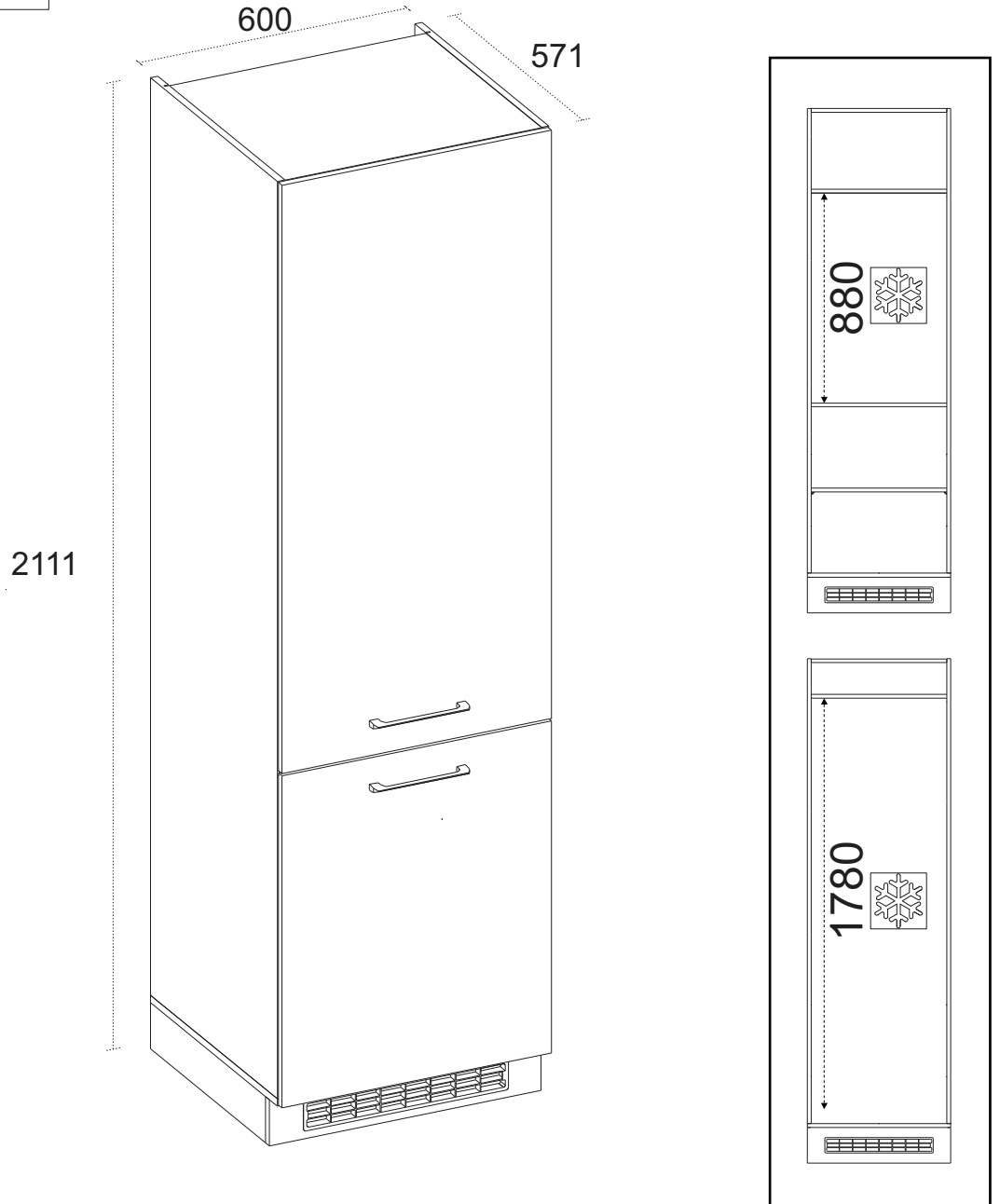

N	L [mm]	W [mm]	T [mm]	Q	COLLI
1	713	596	16	1	COLLI_1/2
2	1238	596	16	1	COLLI_1/2
3	715	583	3	1	COLLI_1/2
4	583	354	3	1	COLLI_1/2
5	583	160	3	1	COLLI_1/2
8	504	150	16	2	COLLI_1/2
9	600	150	16	1	COLLI_1/2
10	600	555	16	1	COLLI_1/2
11	567	500	16	1	COLLI_1/2
6	1945	555	16	1	COLLI_2/2
7	1945	555	16	1	COLLI_2/2
12	567	510	16	1	COLLI_2/2
13	567	508	16	2	COLLI_2/2

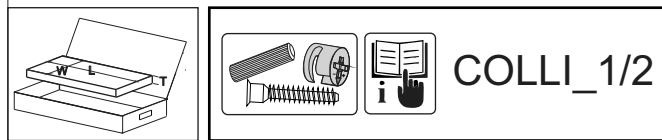

W5 16	PP 4	PMO2 4	
U18 2	KO1 1	KS1 2	
W4 10	W1 15	ZM1B 12	
ZM1A 12	KRW1 2	KRL1 2	
ZM1 8	ZPH 5	K3 4	
S1 8	NK1 4	KN1 6	
KT1 16	W11 32	KK1 1	WU 4

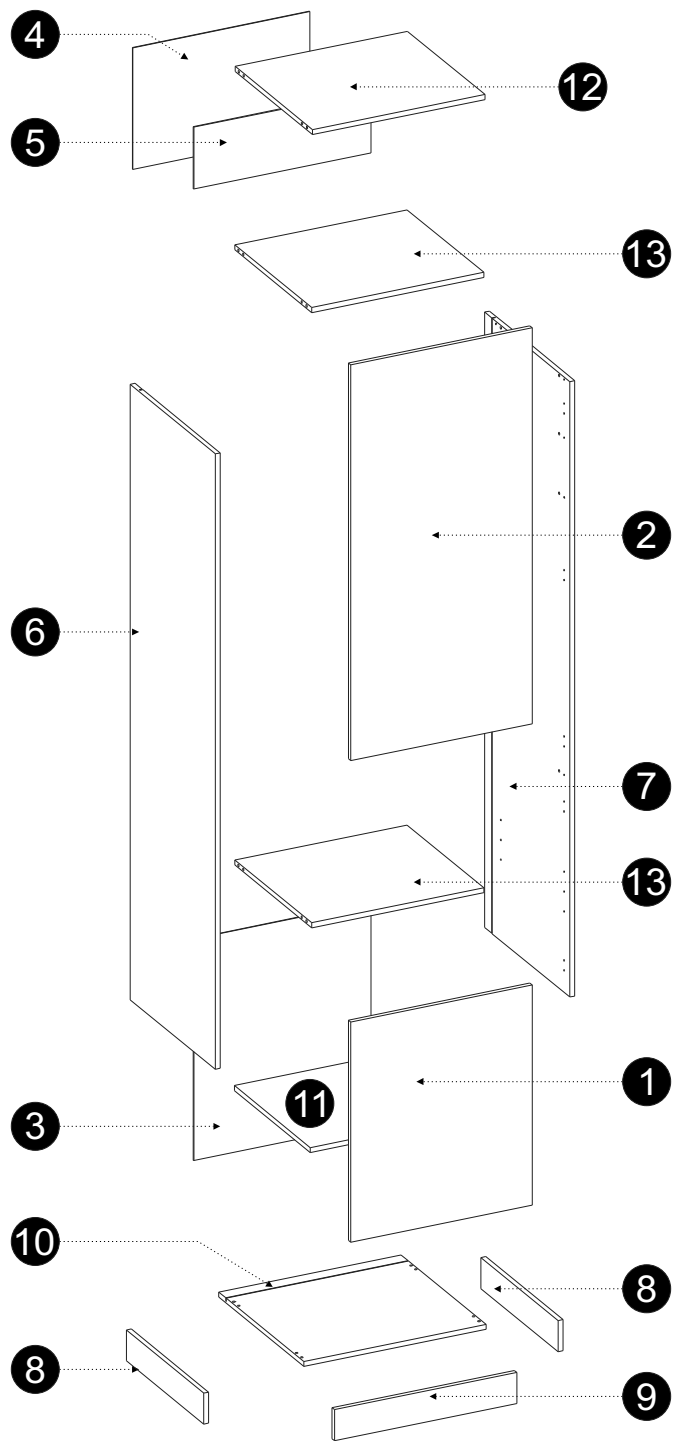



11-21

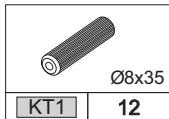
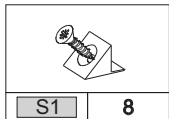
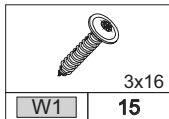
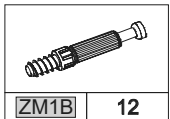
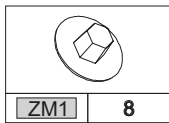
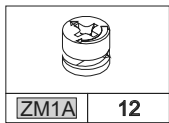
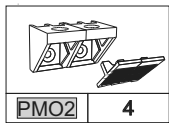
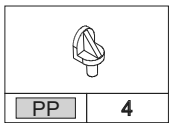
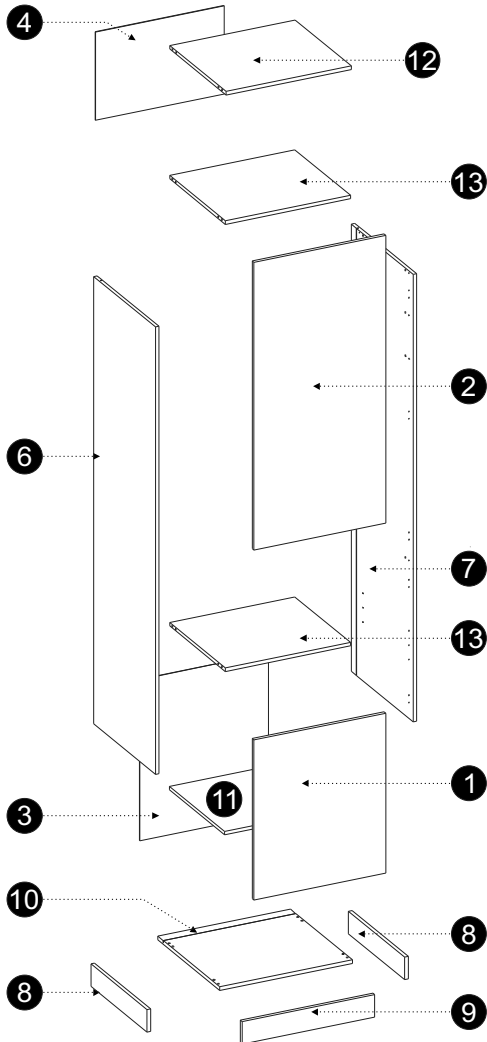
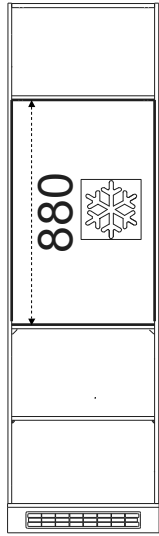

4-10 18-21

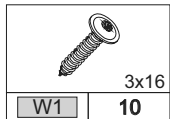
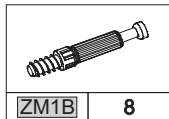
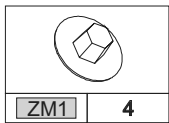
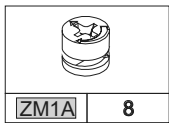
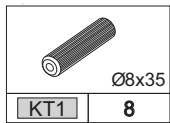
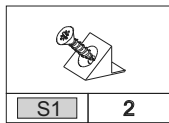
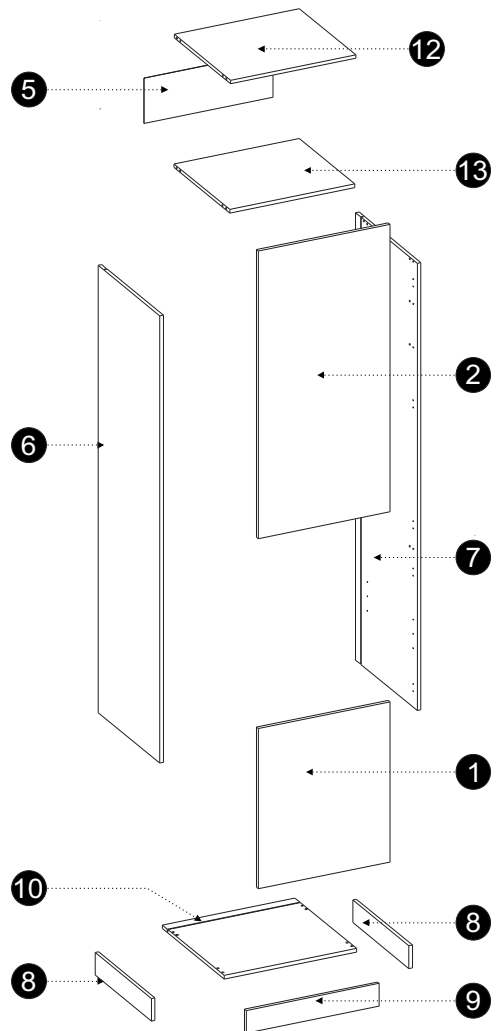
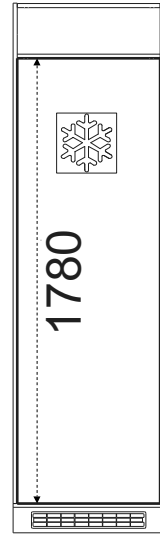

01

ZM1B	KT1	ZM1A
8	12	8

Ø8x35

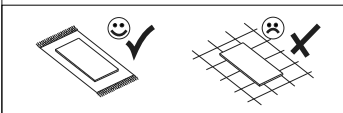
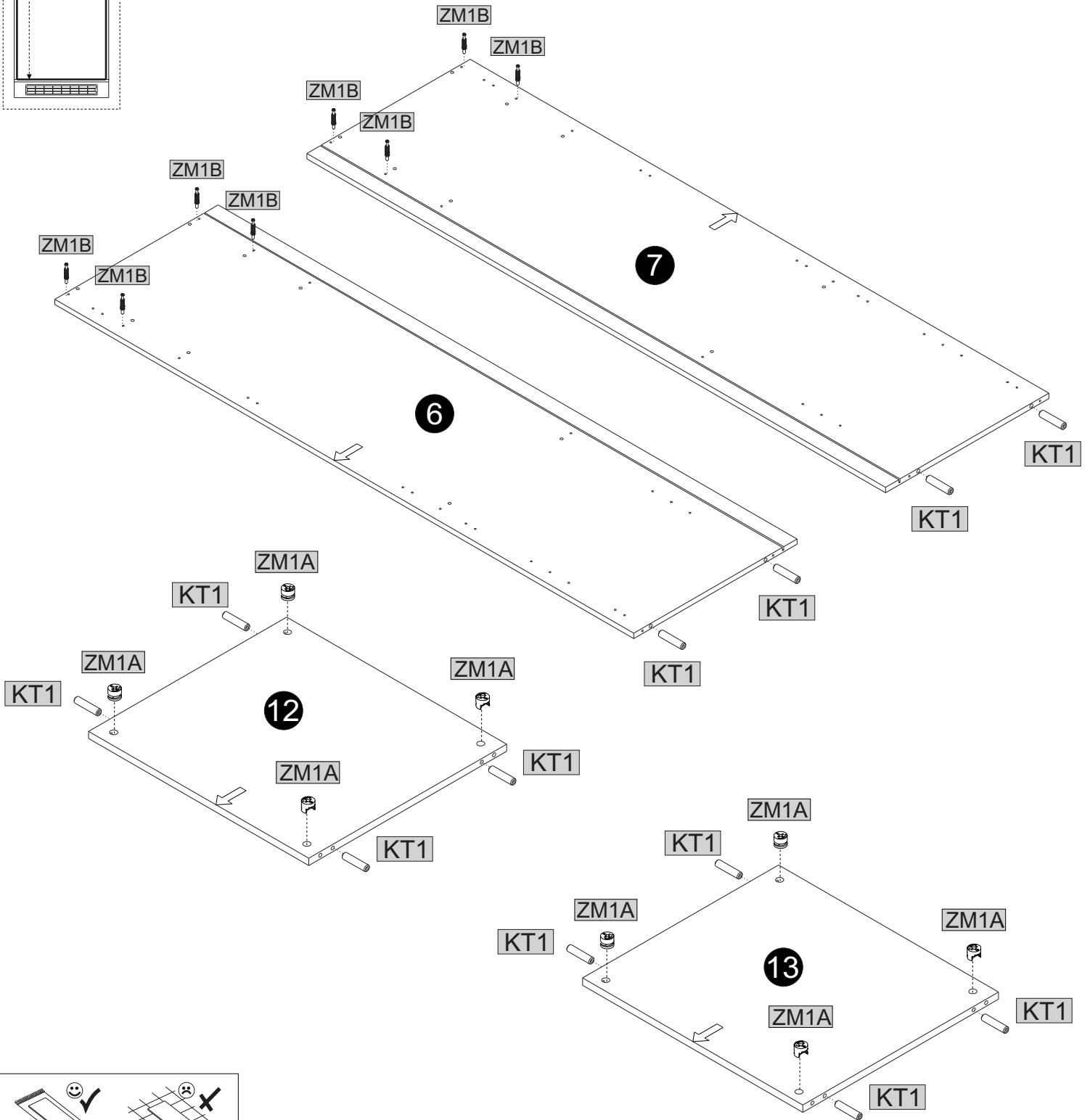
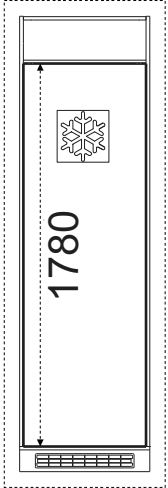
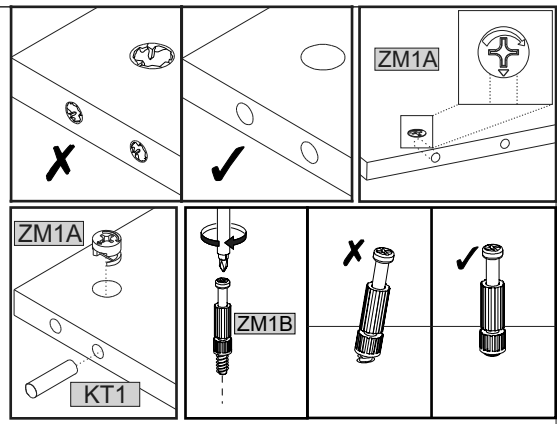

02

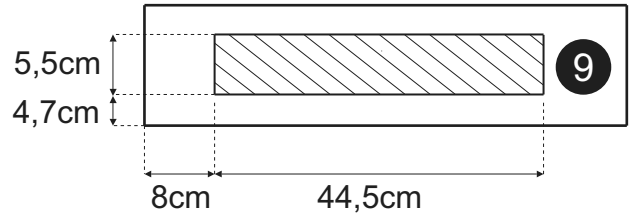
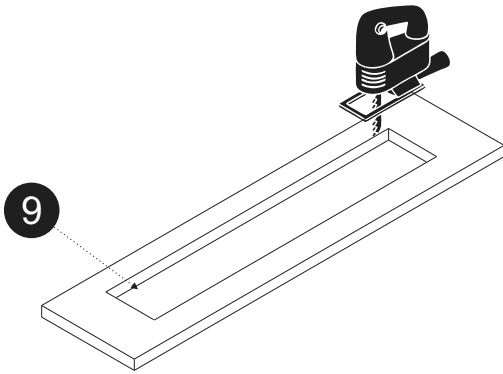
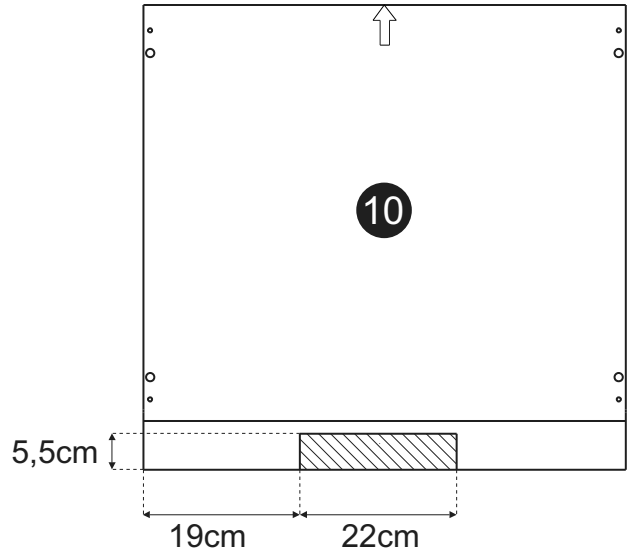
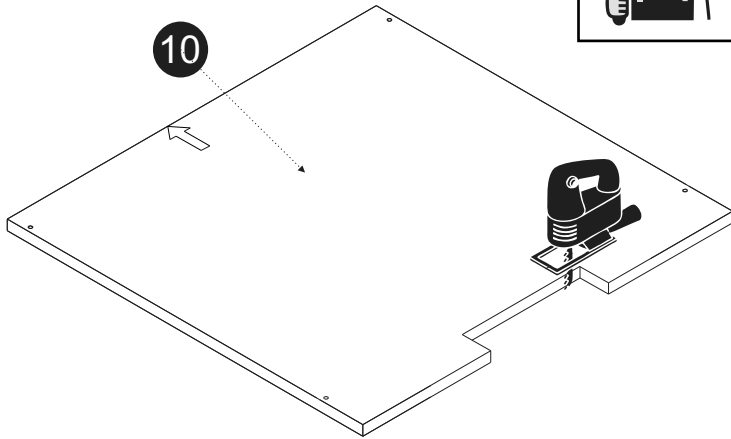

03

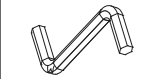
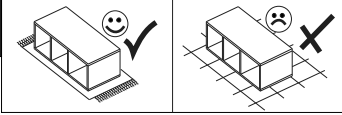

KK1 1

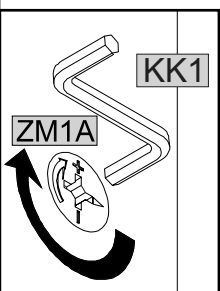
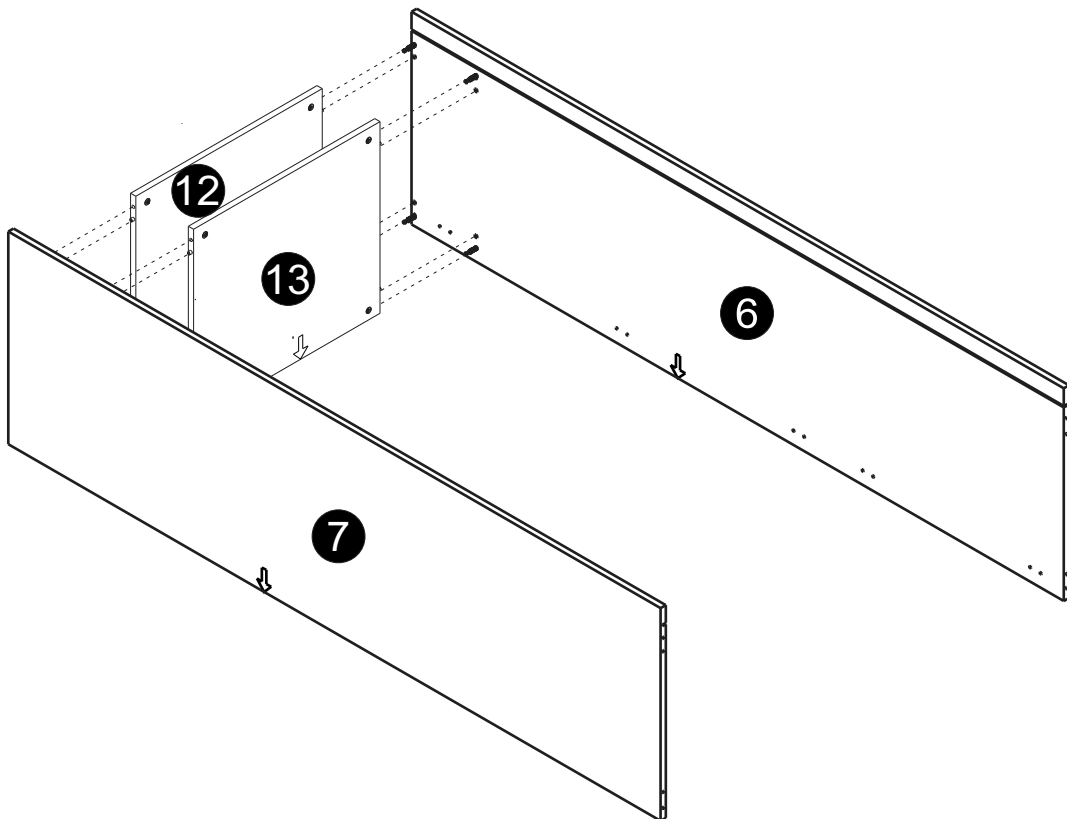

04

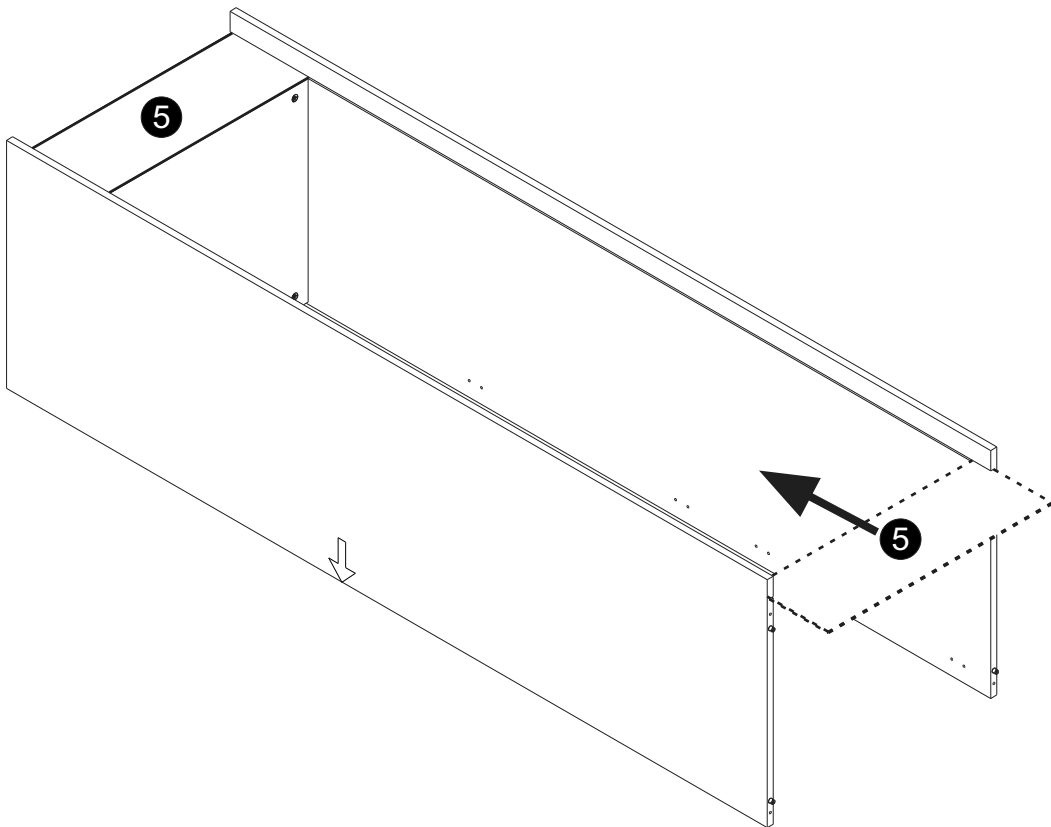
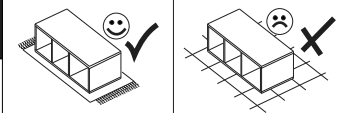

05

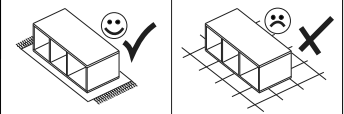

			6,4x50
KK1	1	K3	4

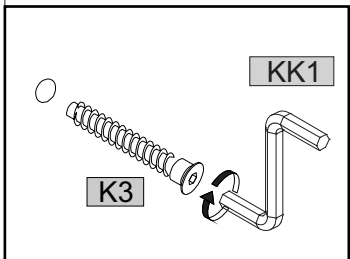
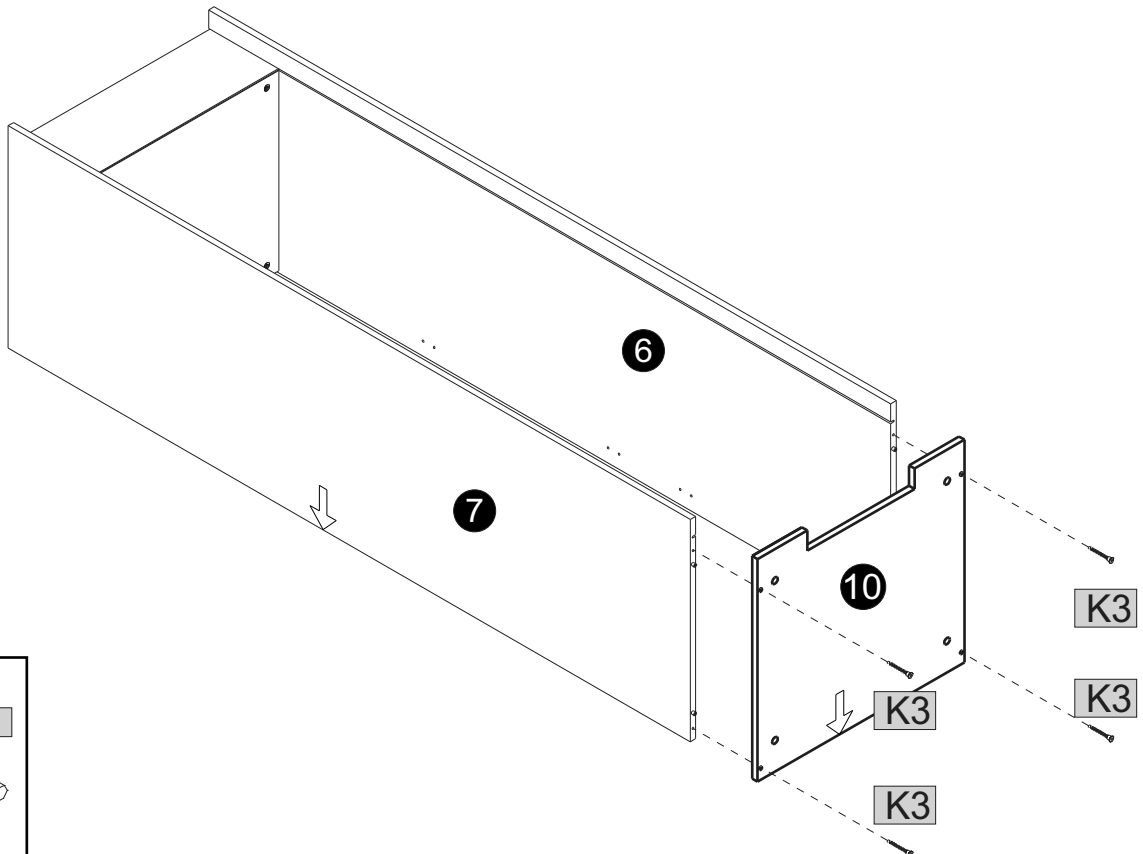

06

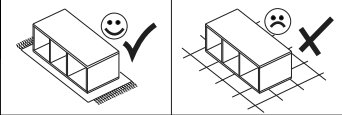

		3x16
S1	2	W1
		10

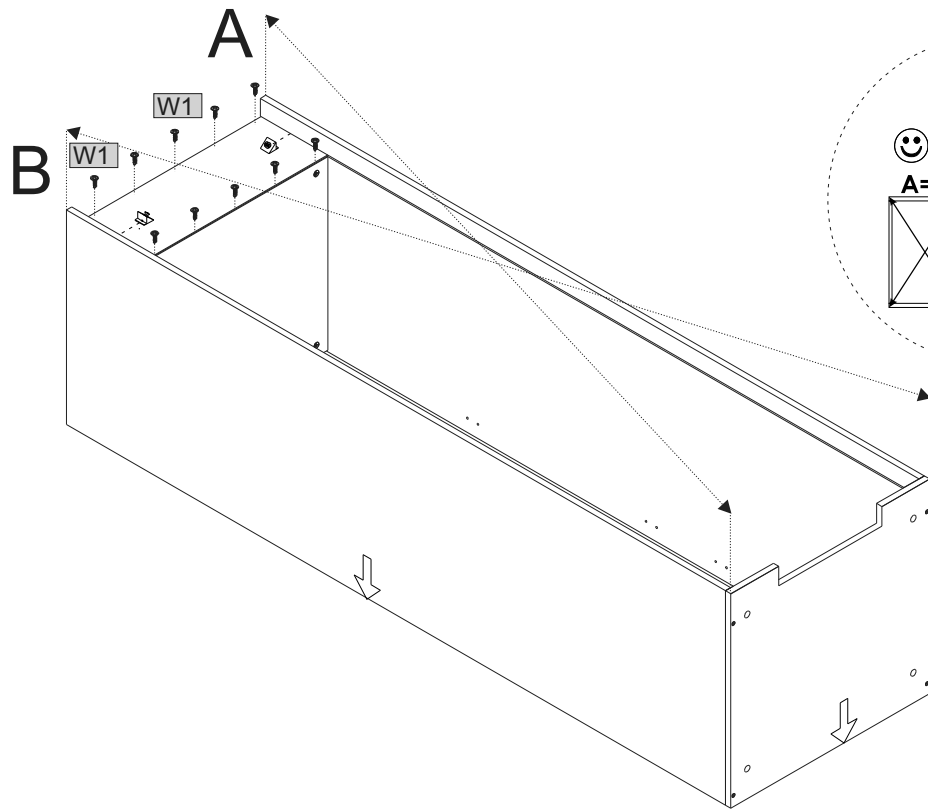
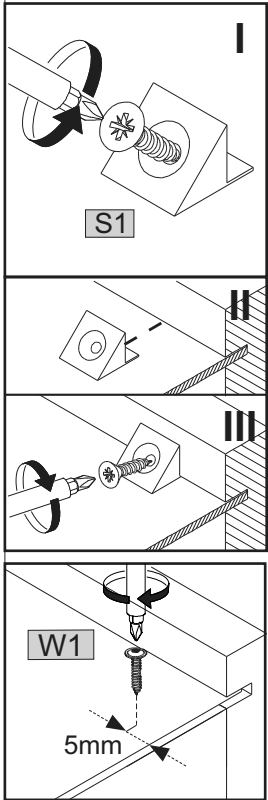



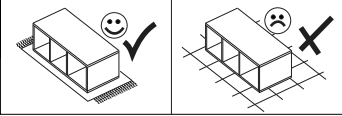

07

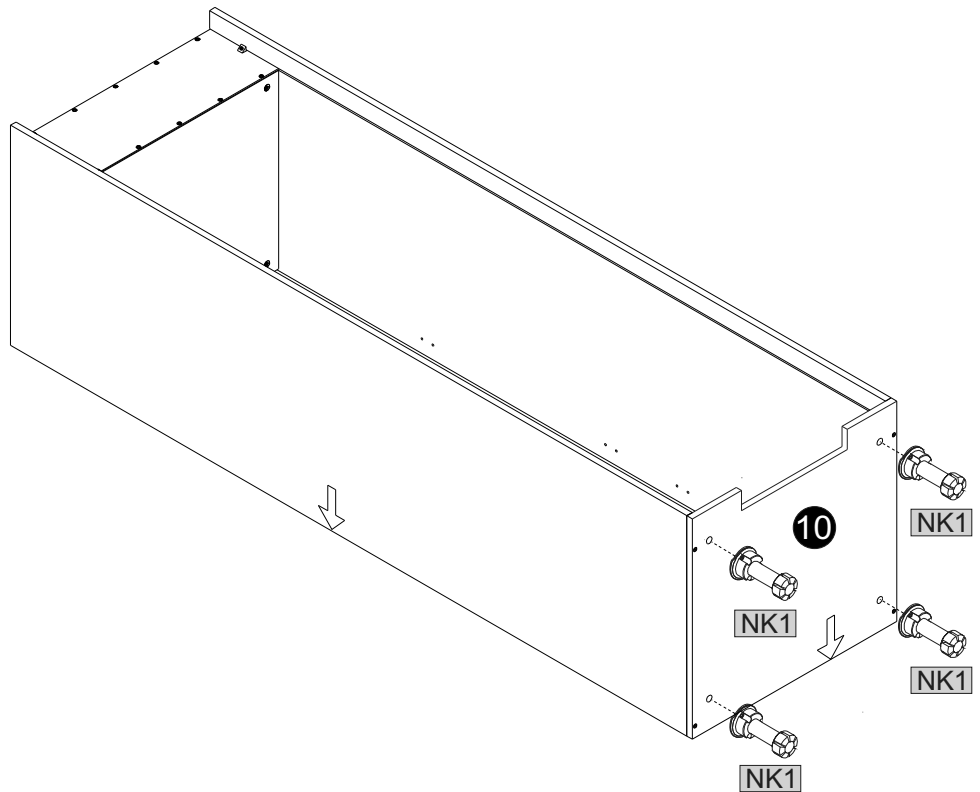
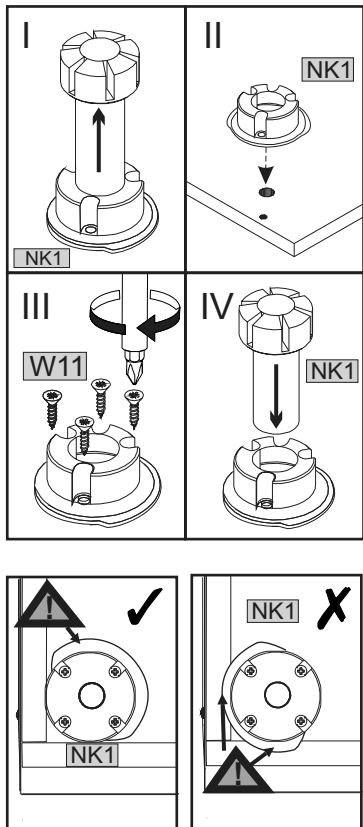

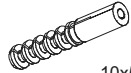
		3,5x16
W11	16	NK1
		4



	10x50		6x50		3,5x16		
KRW1	2	KRL1	2	W11	4	KS1	2

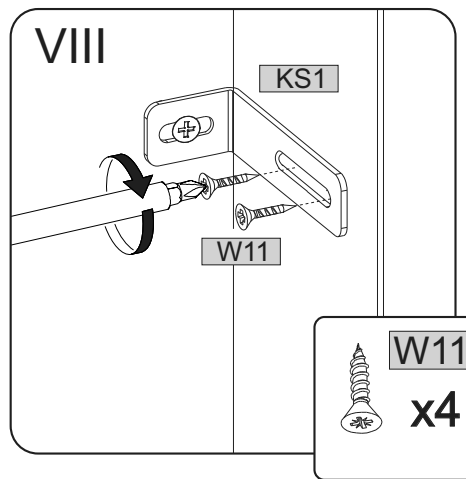
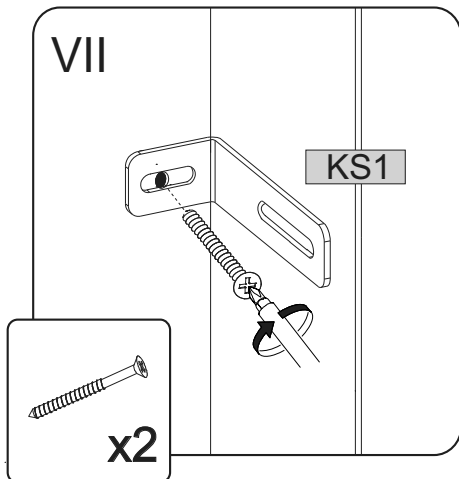
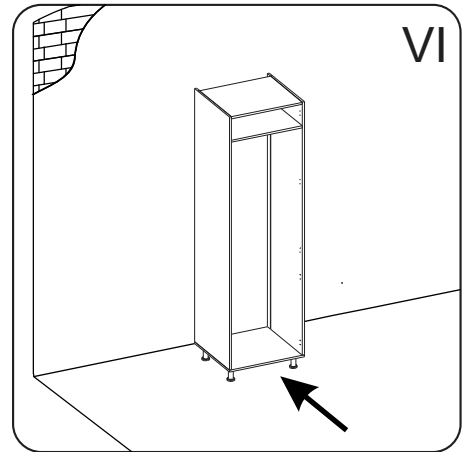
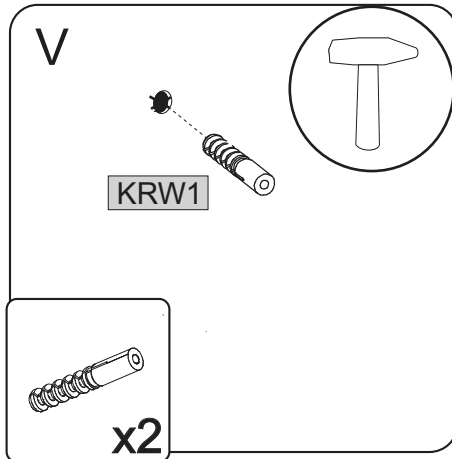
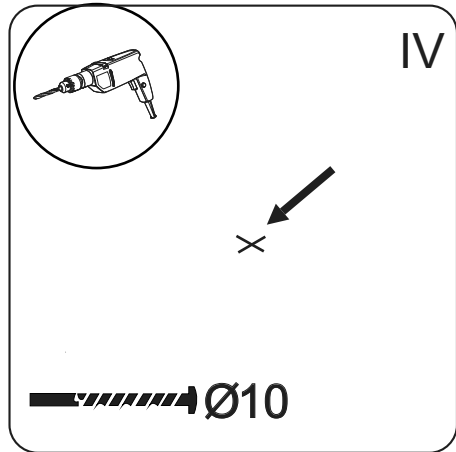
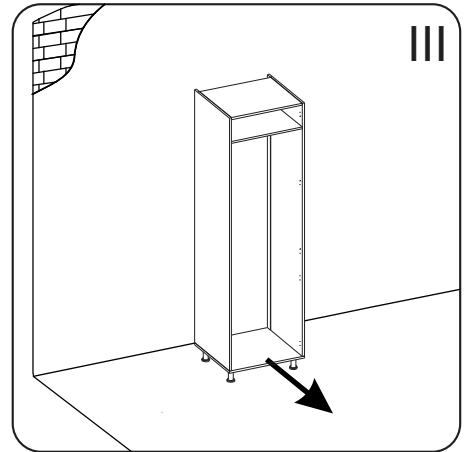
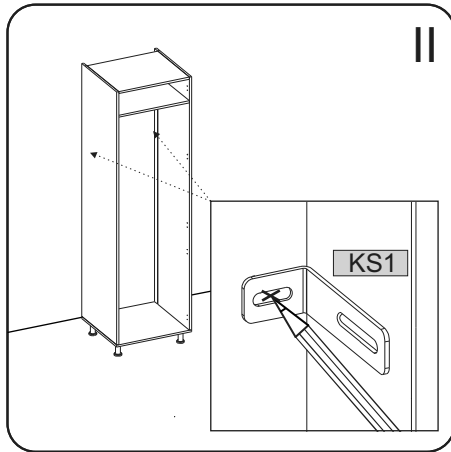
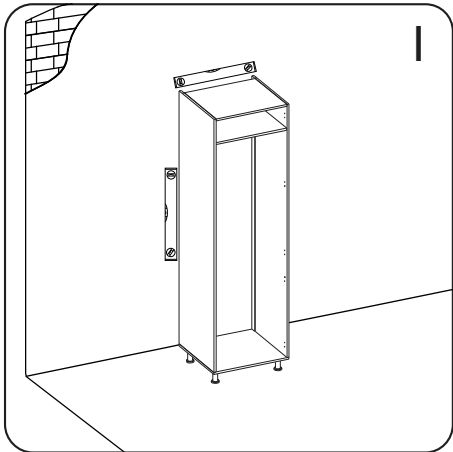
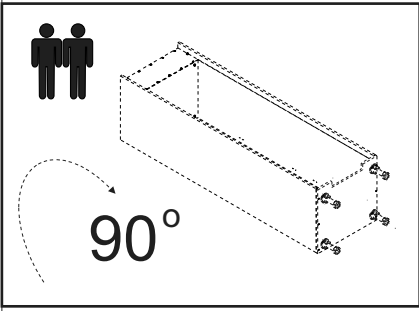

09

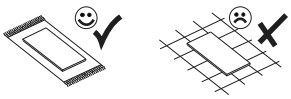

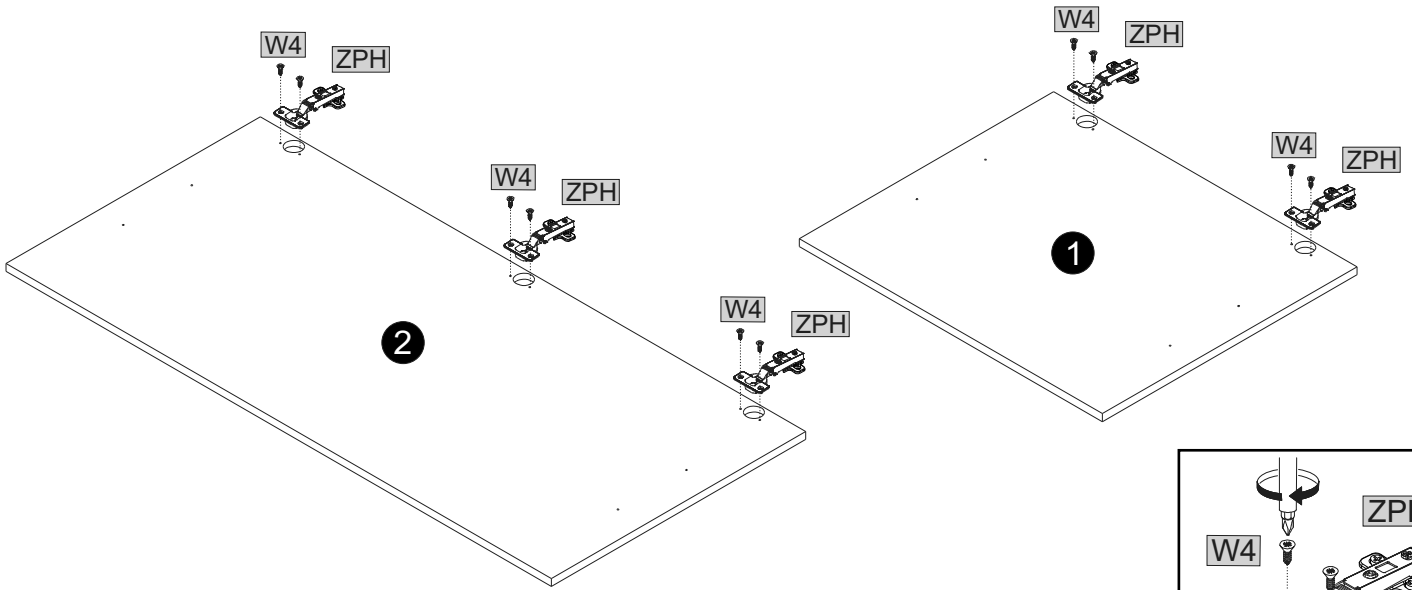

		4x13	
W4	10	ZPH	5

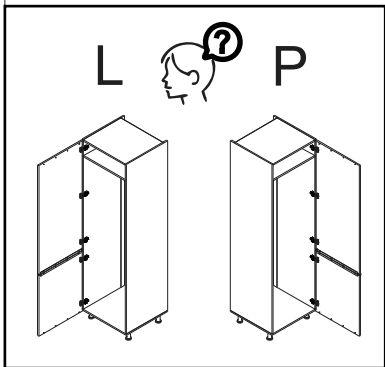

10

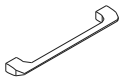

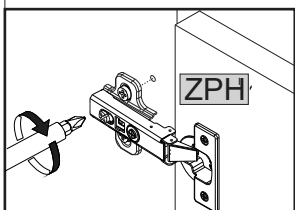
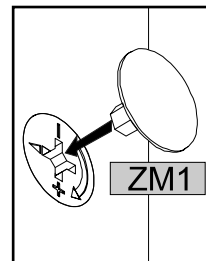
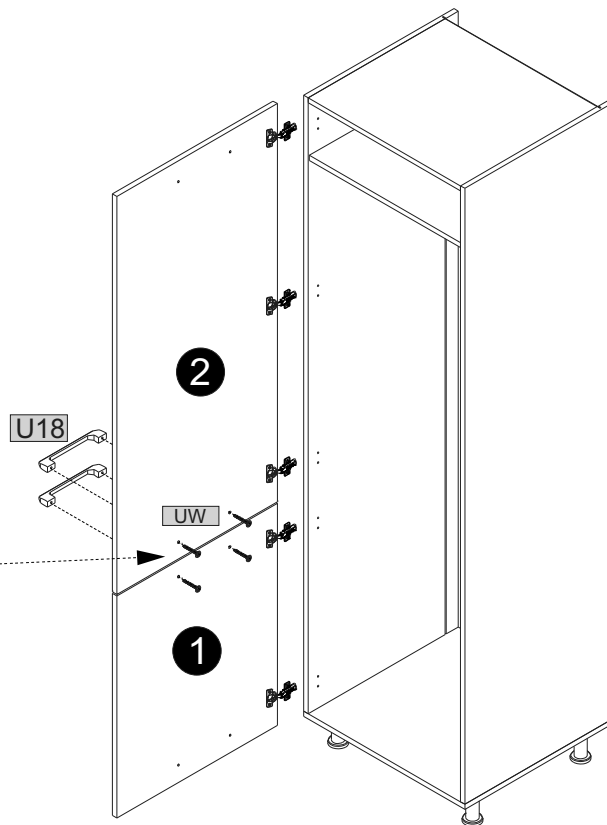
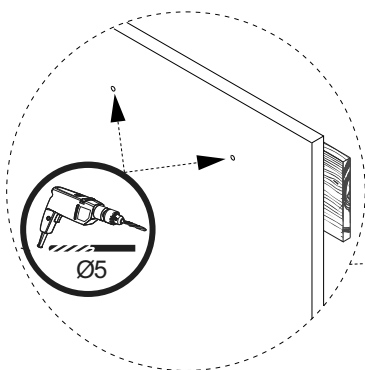

		3,5x25	
WU	4		
			
U18	2		
			
ZM1	4		

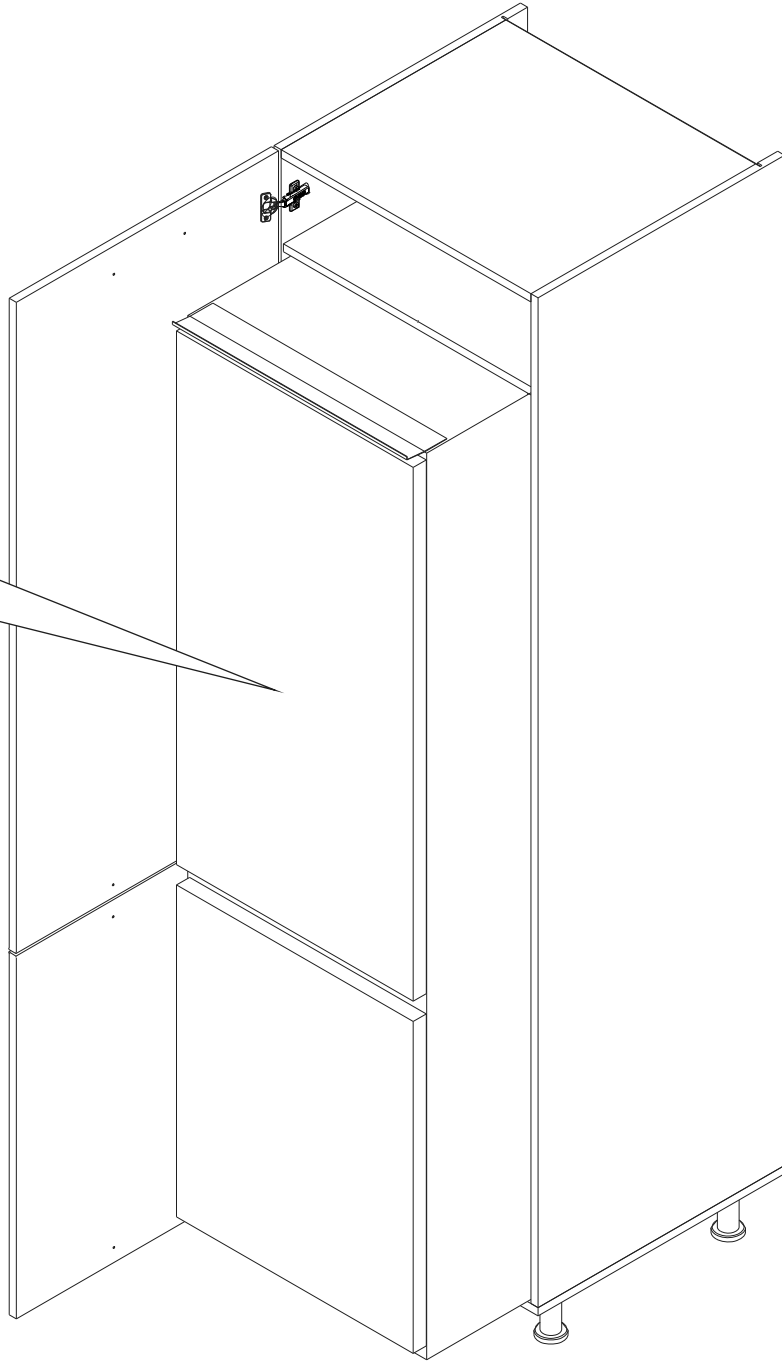
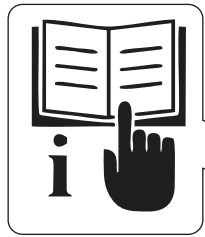

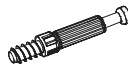

→ 18-20

		
ZM1B	KT1	ZM1A
12	16	12

Ø8x35

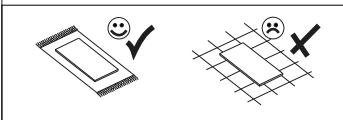
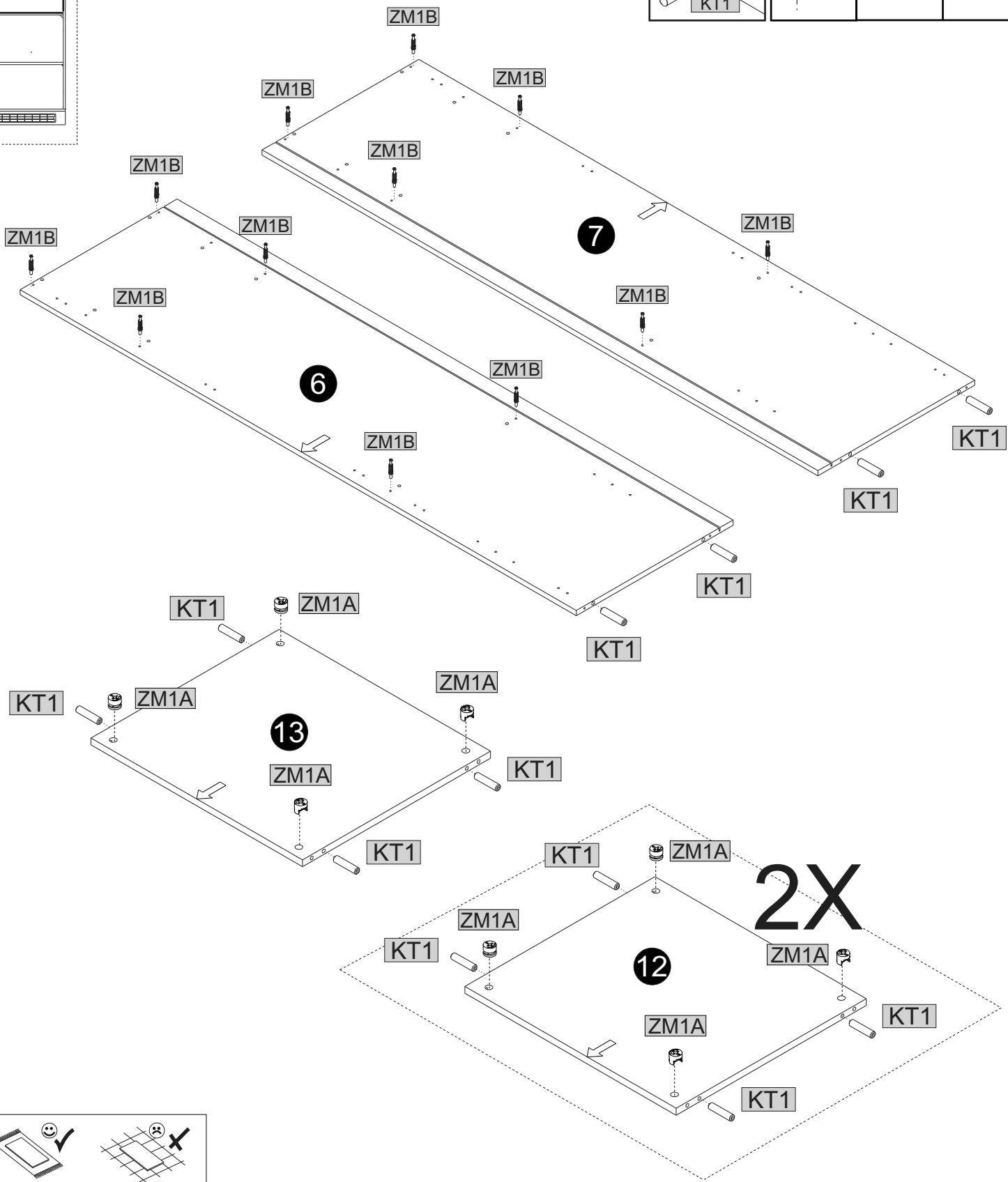
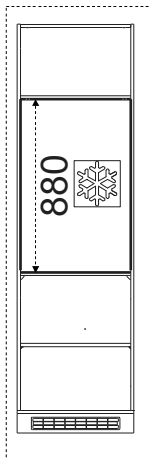
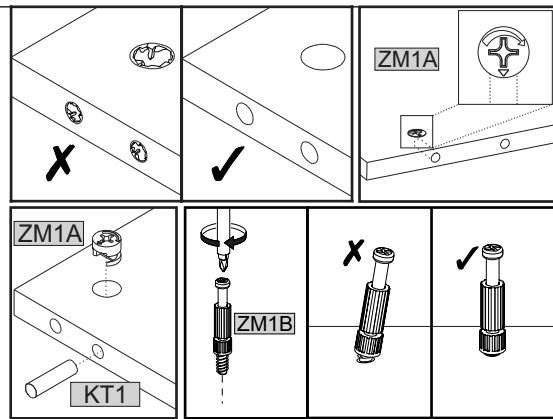

02

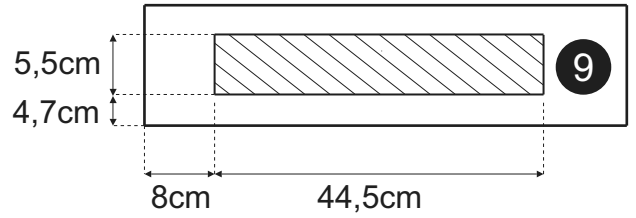
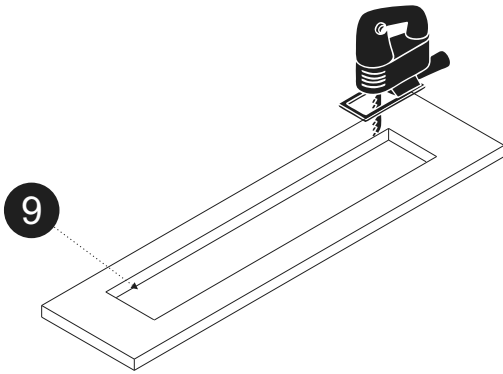
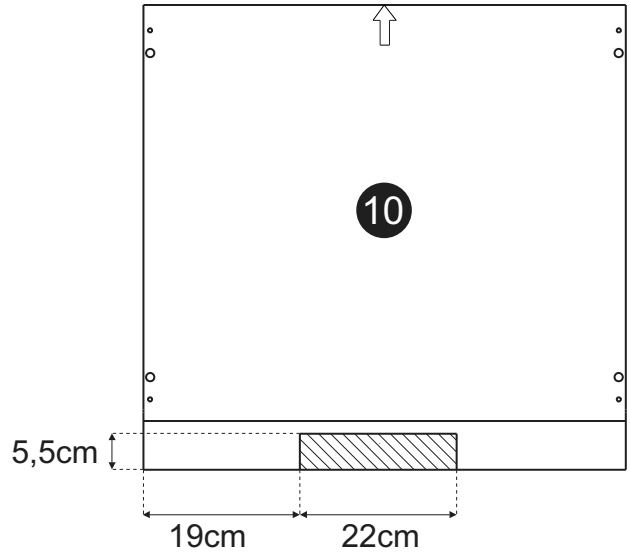
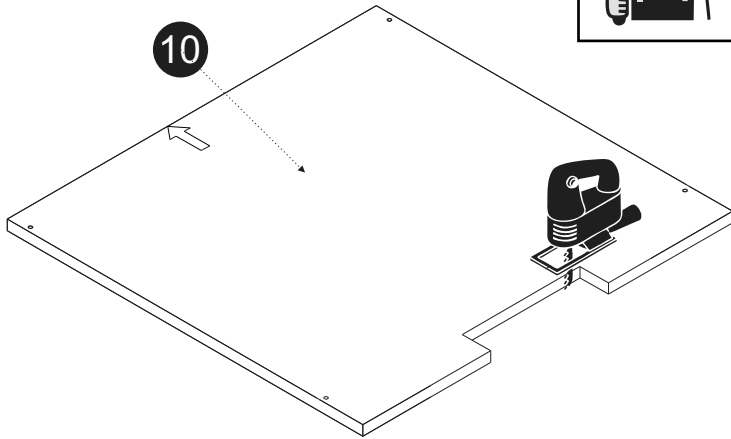

03

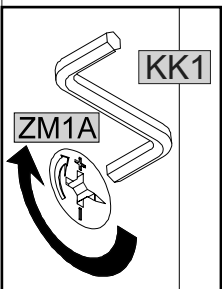
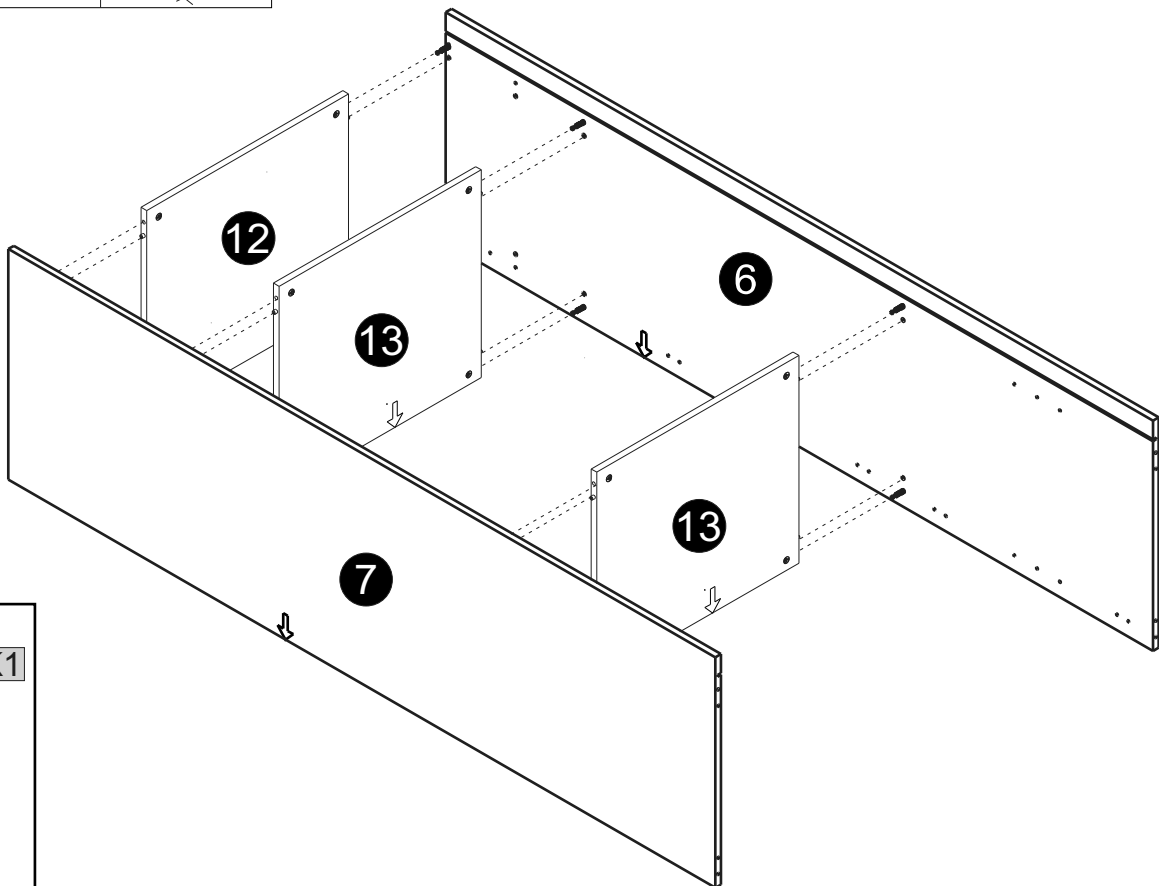
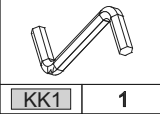
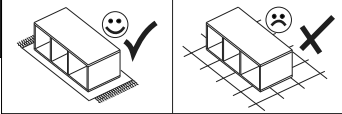

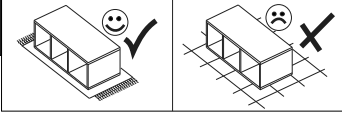
04

4x16			
W5	16	PMO2	4

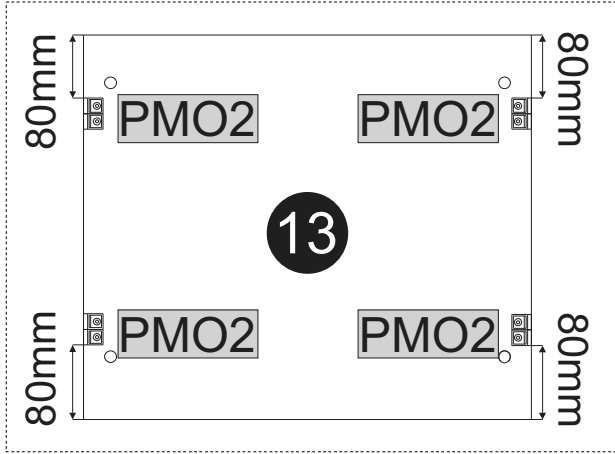
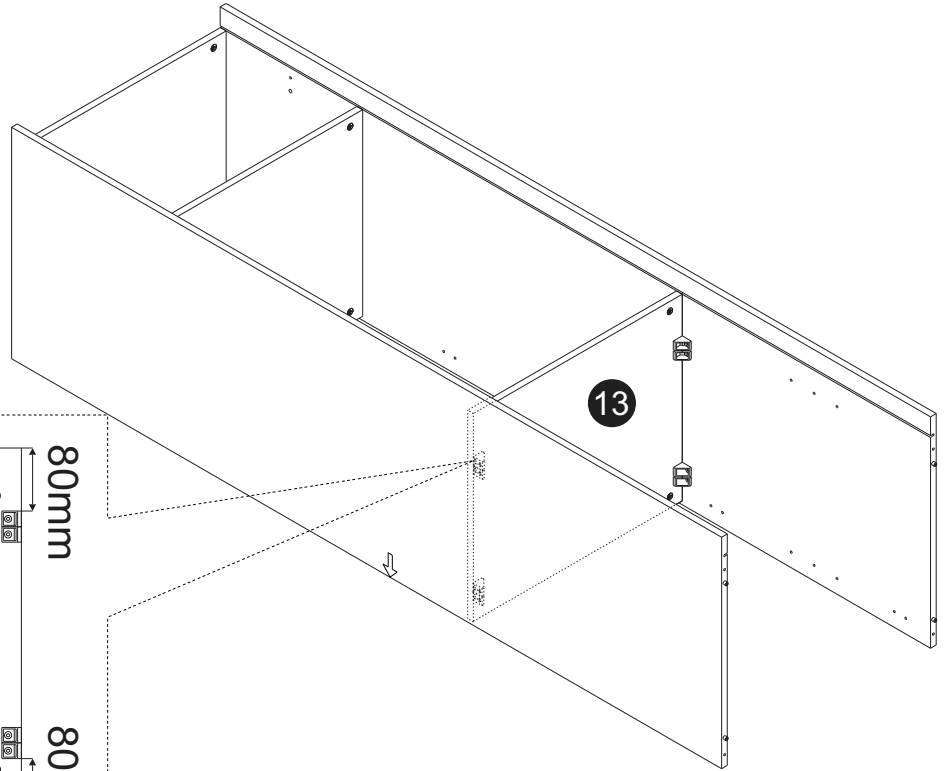
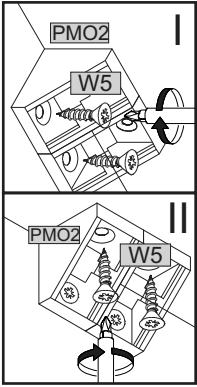
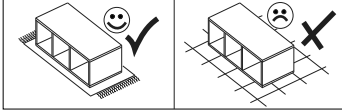

**05**

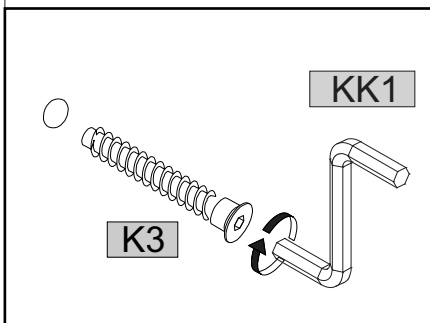
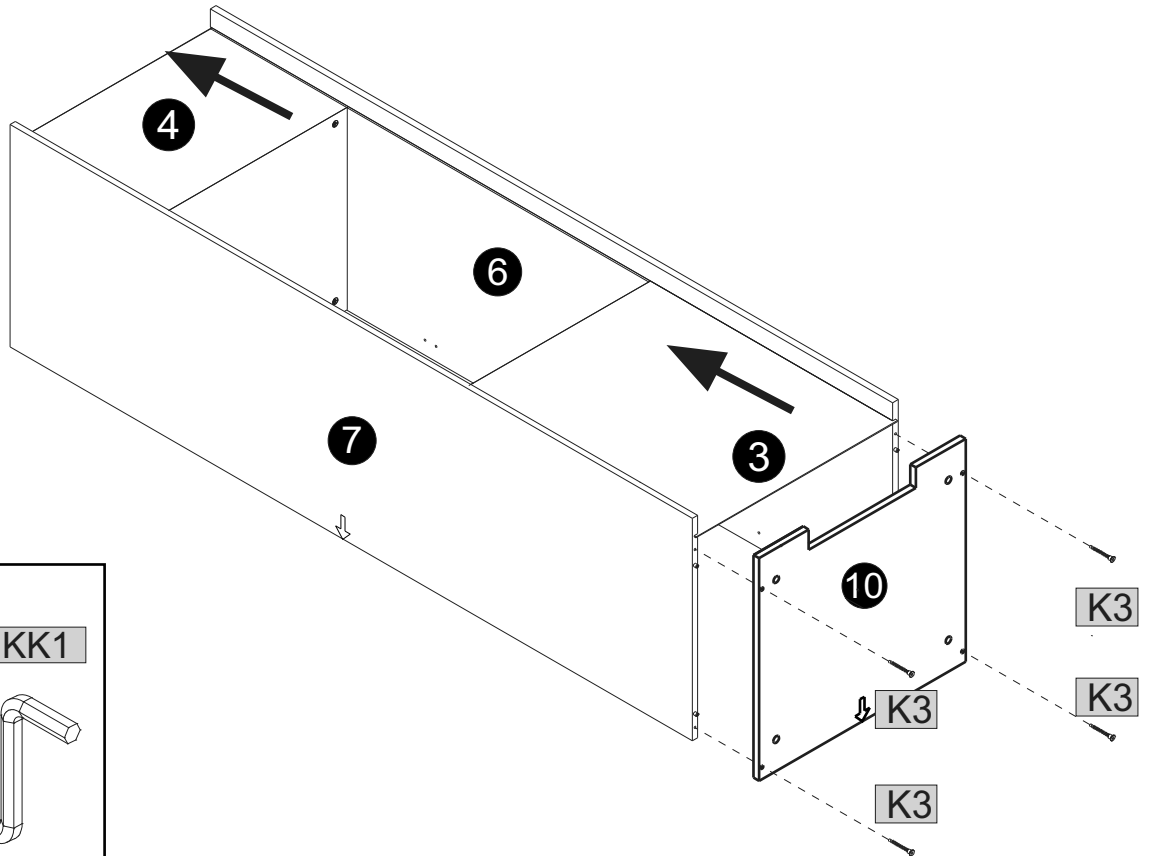
KK1	1	K3	3
		6,4x50	

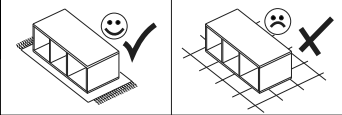

06



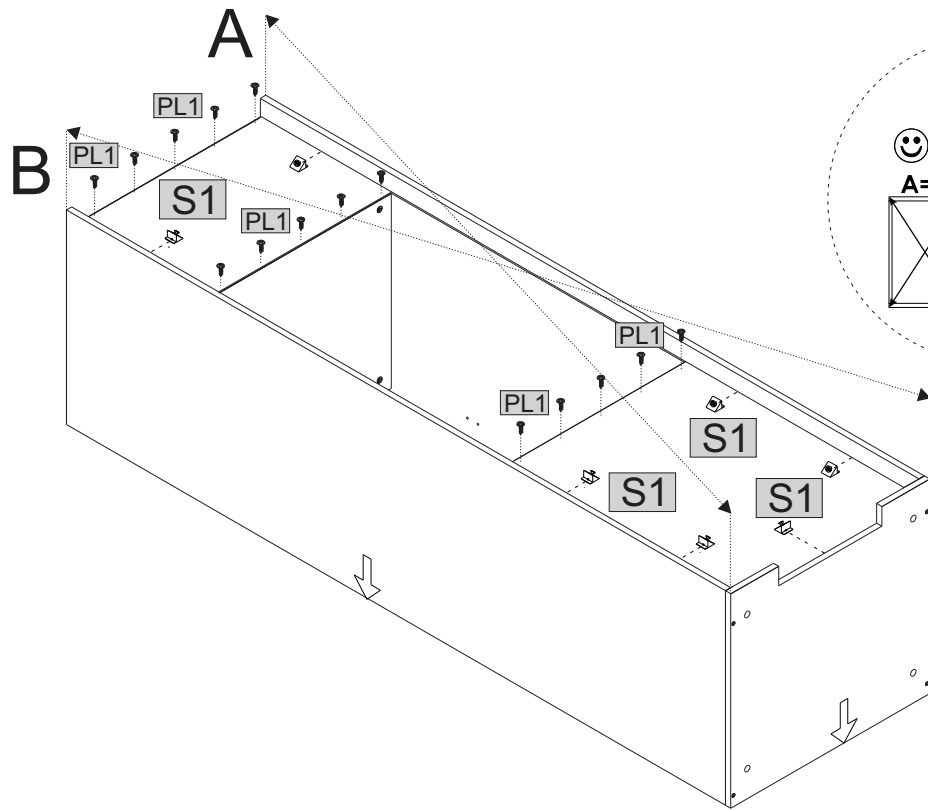
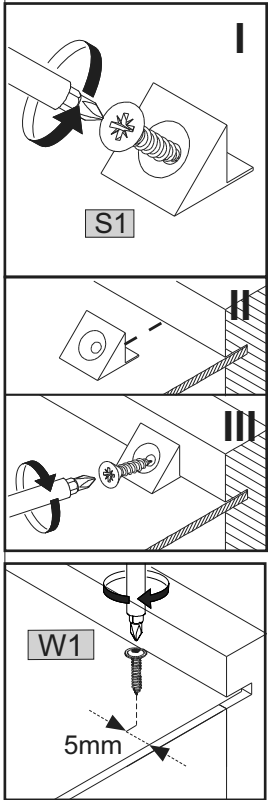

		3x16
S1	7	W1
		15

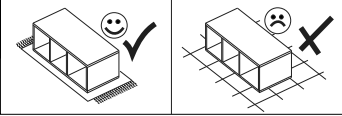

07



		3,5x16
W11	16	NK1
		4

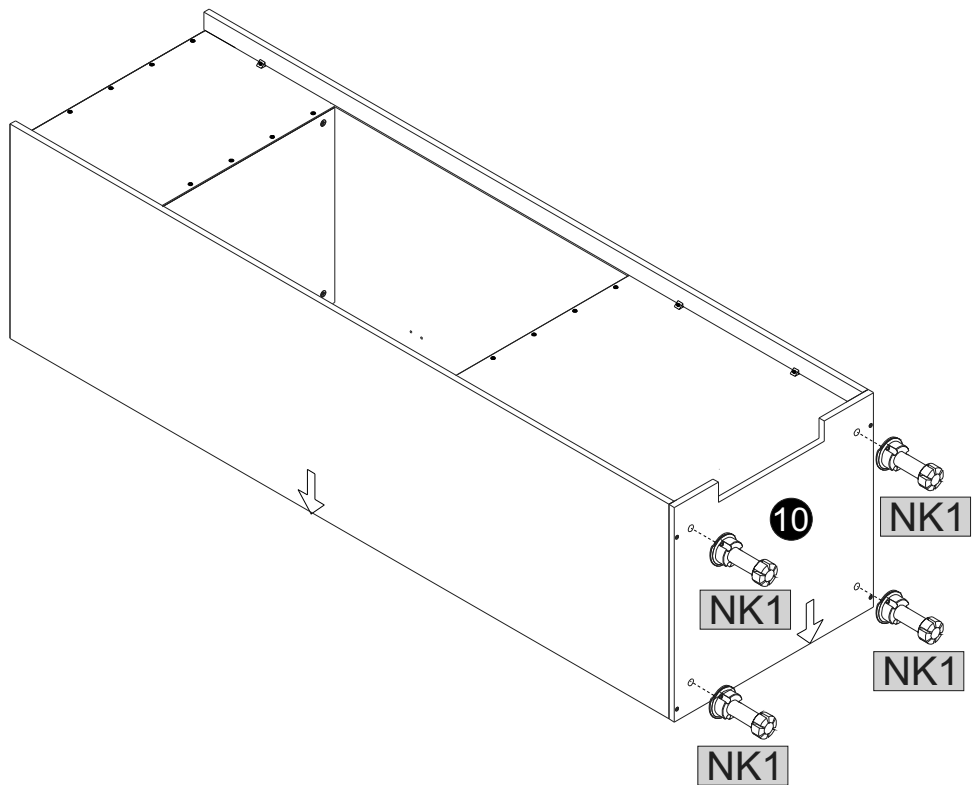
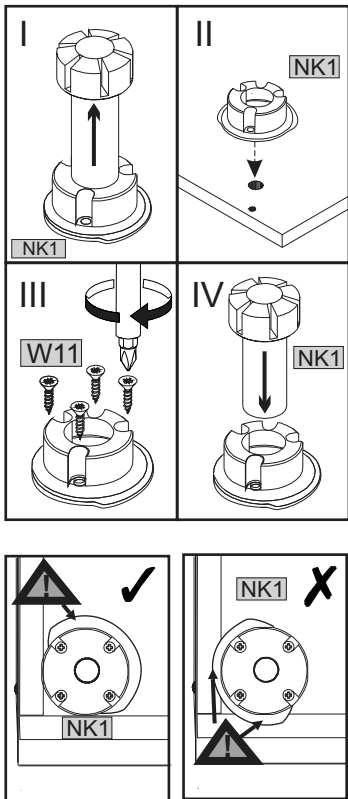

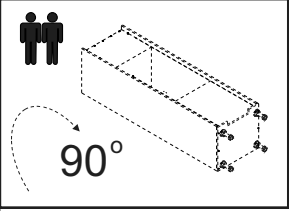

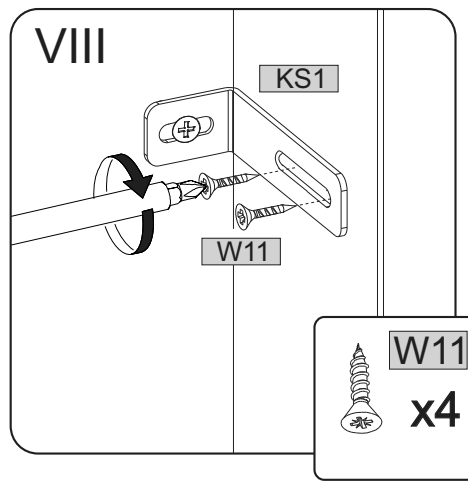
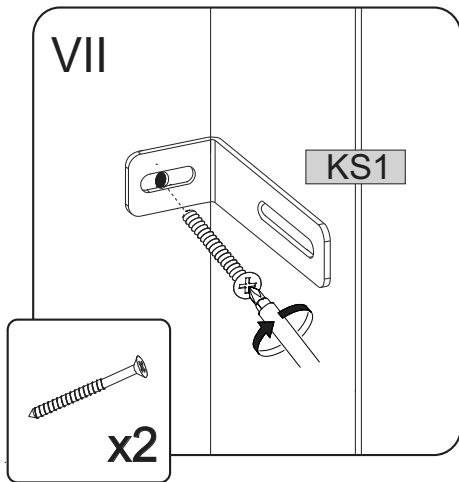
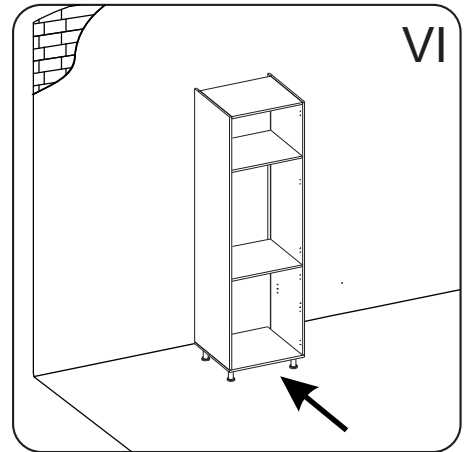
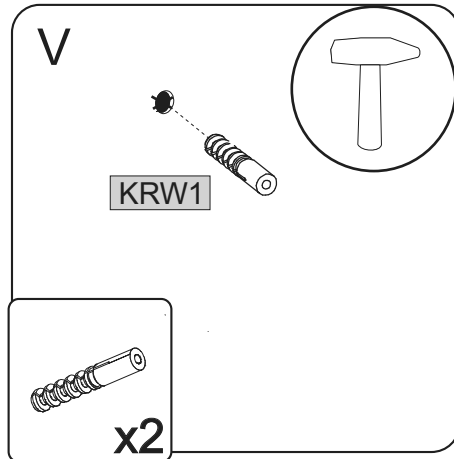
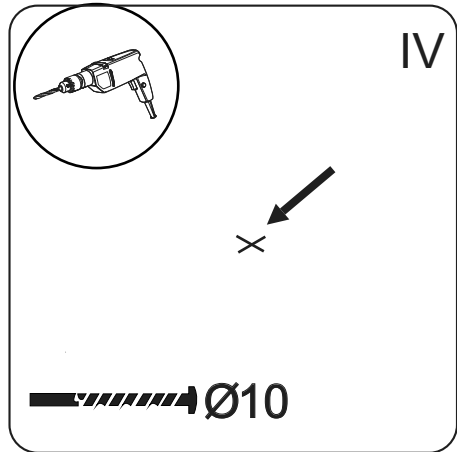
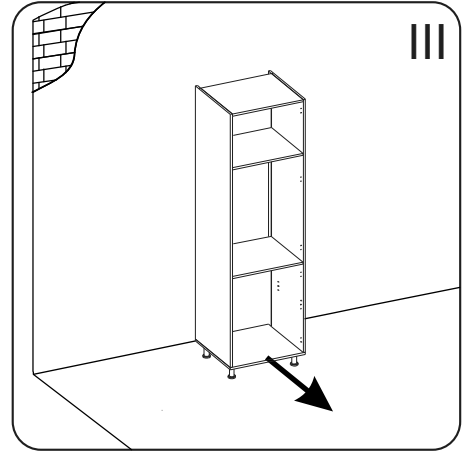
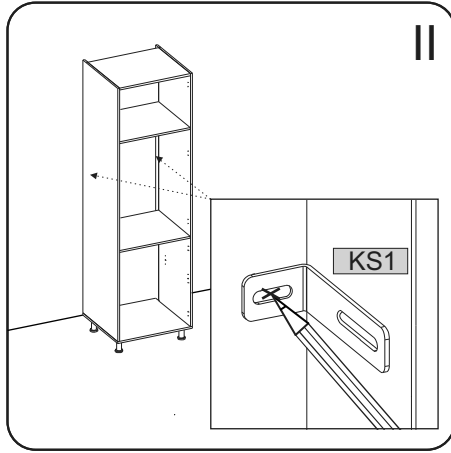
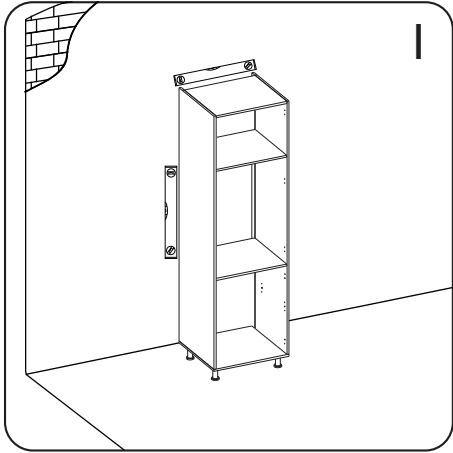

	10x50		6x50		3,5x16		
KRW1	2	KRL1	2	W11	4	KS1	2

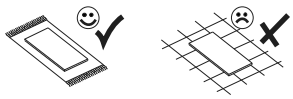

09



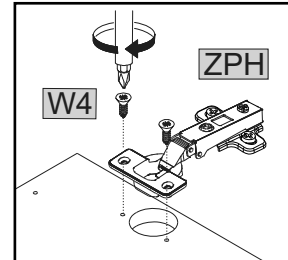
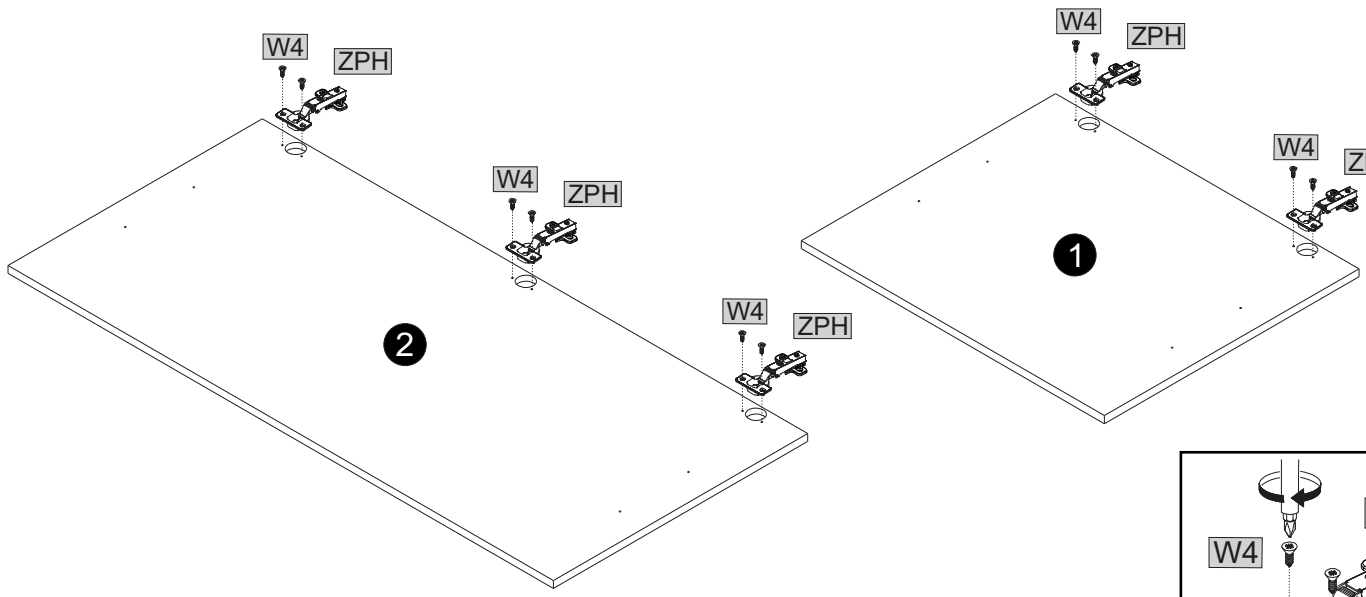

		4x13	
W4	10	ZPH	5

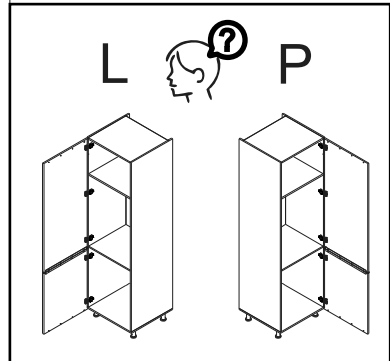

10

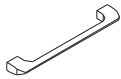

		3,5x25	
WU	4		
			
U18	2		
			
ZM1	8		

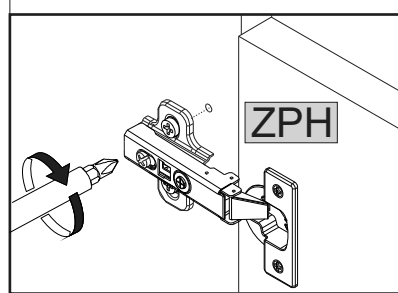
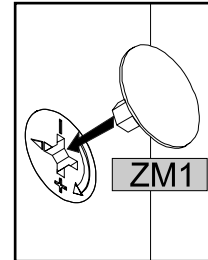
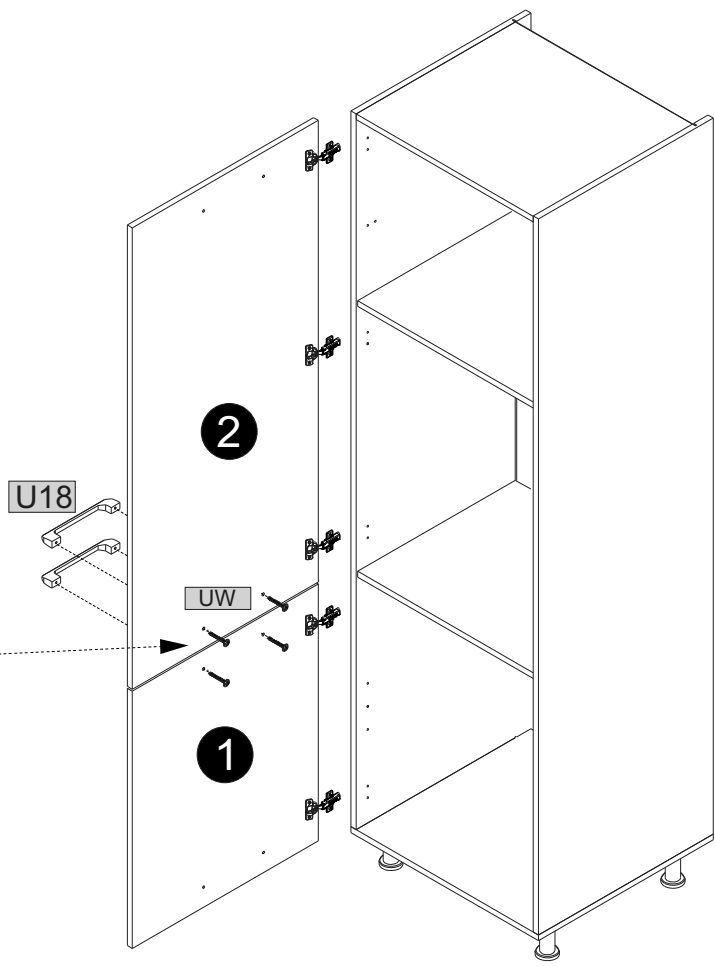
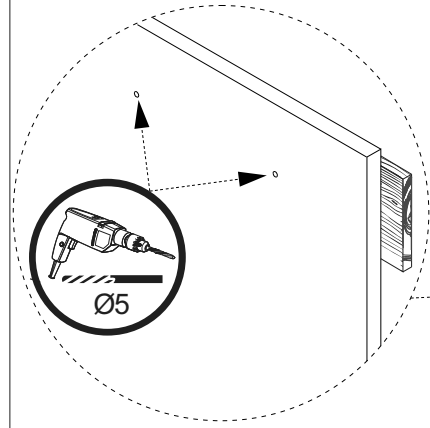



PP

4

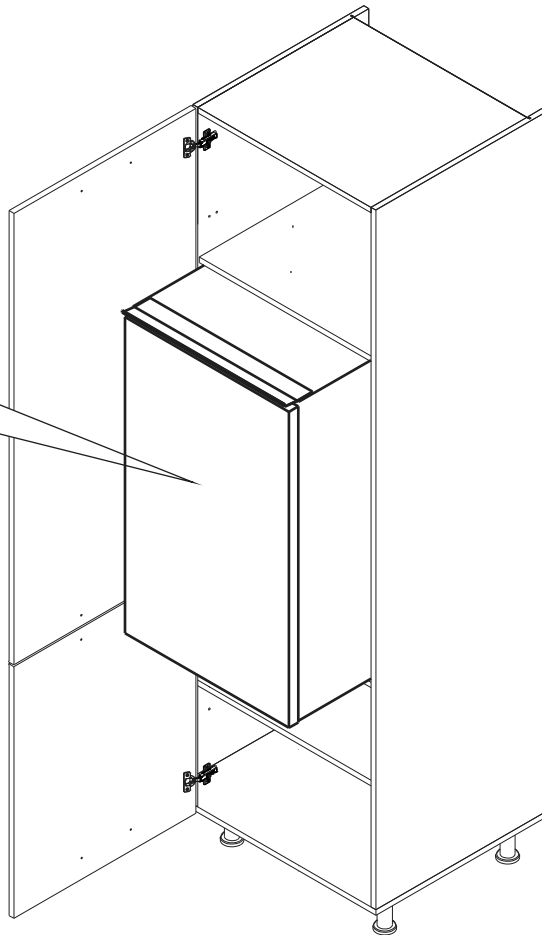
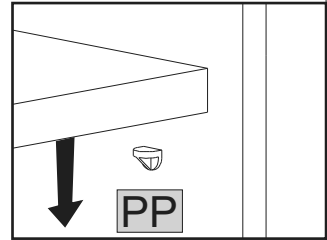
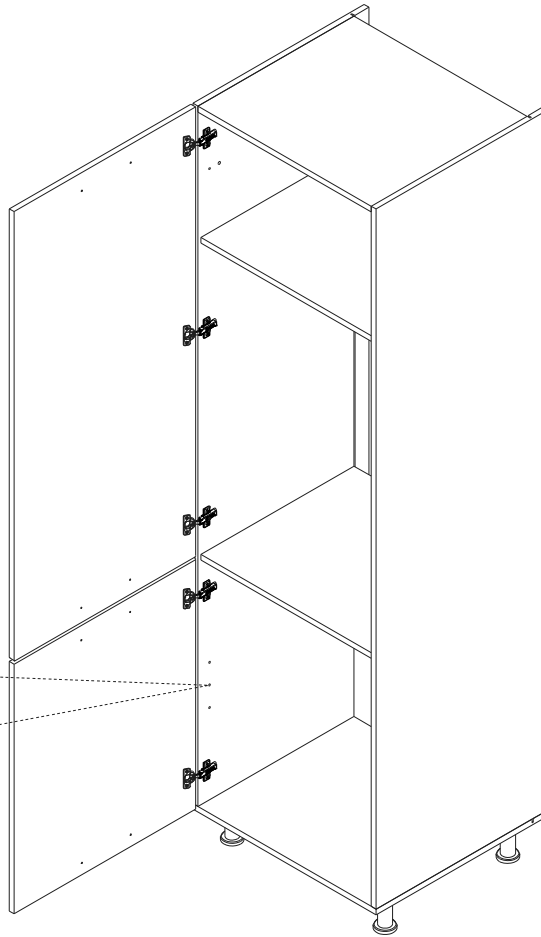
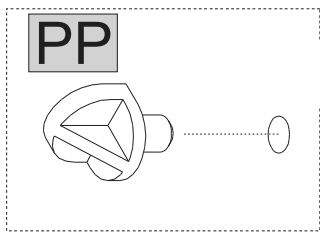

13

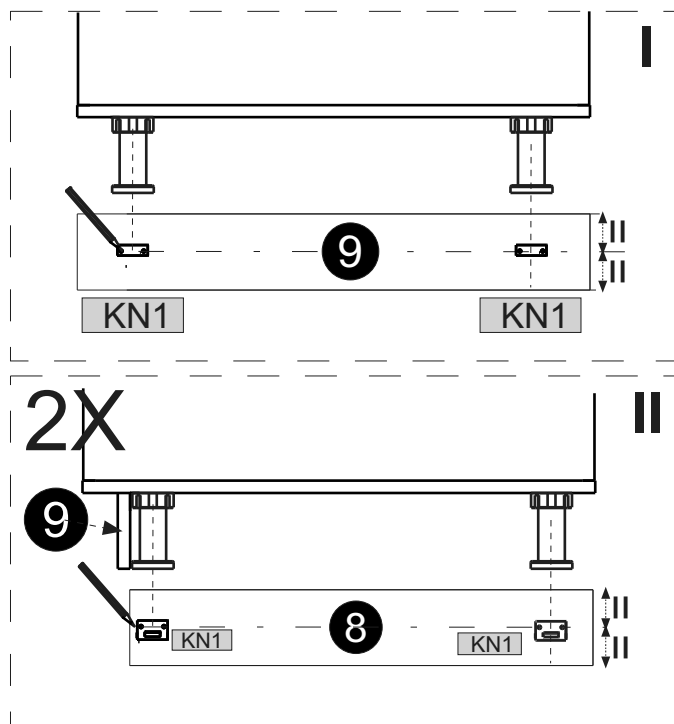
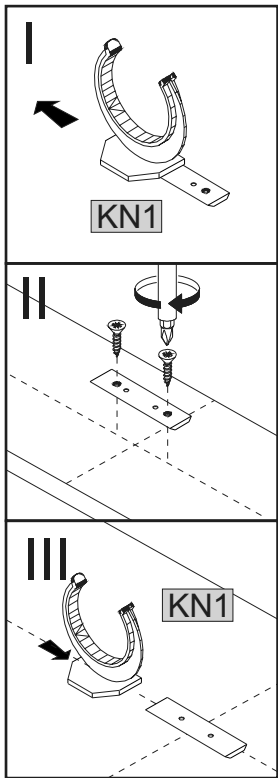

	3,5x16
W11	12
KN1	6

14

KO1	1

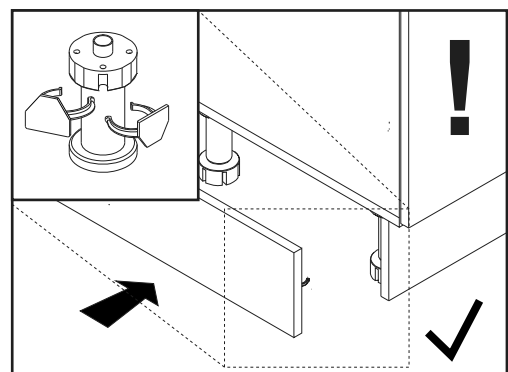
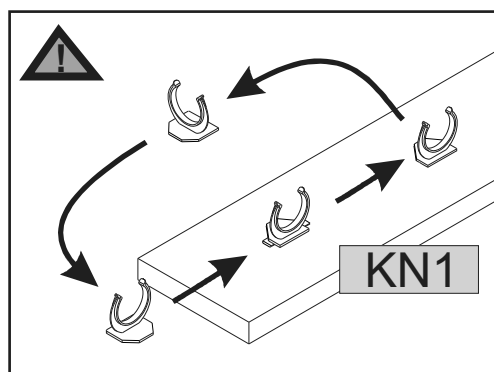
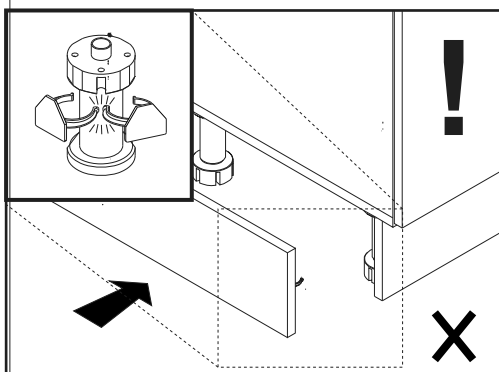
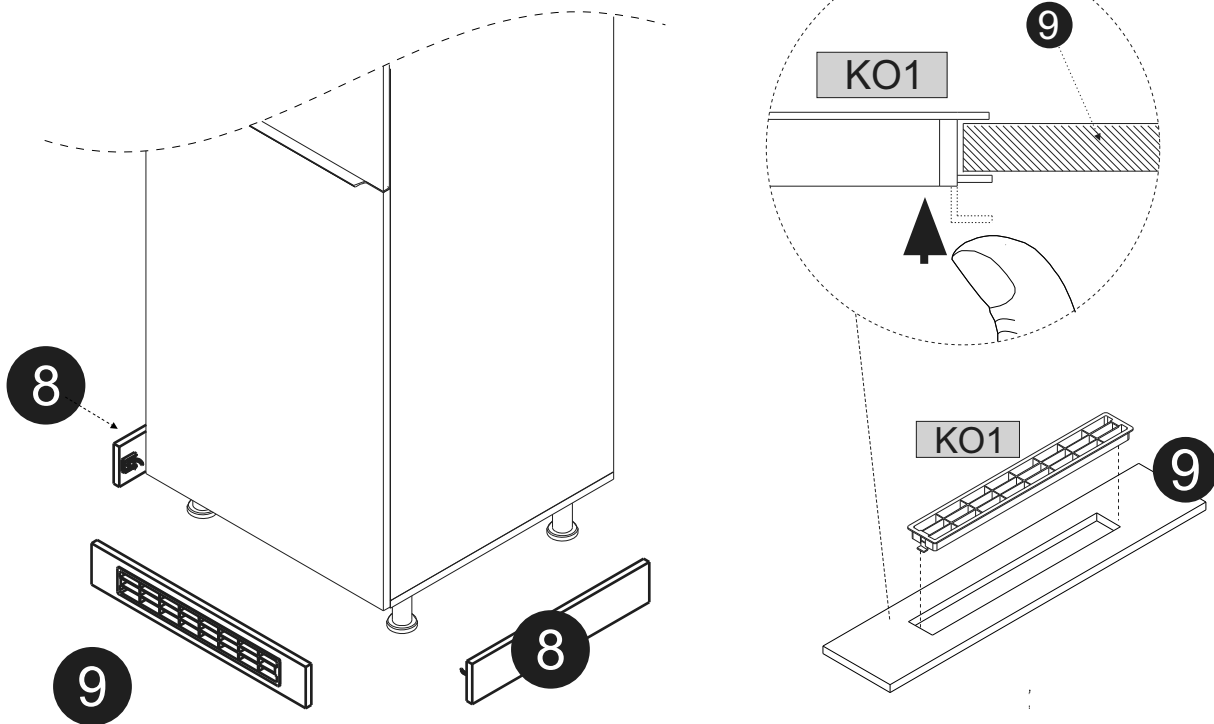

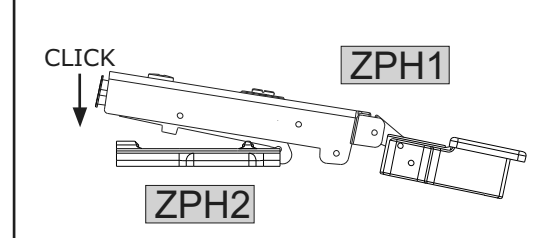
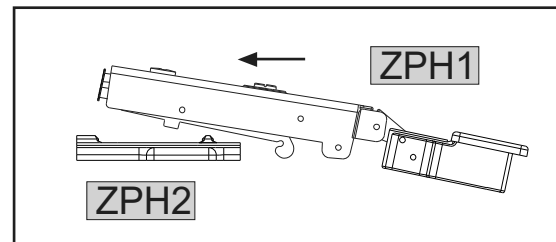
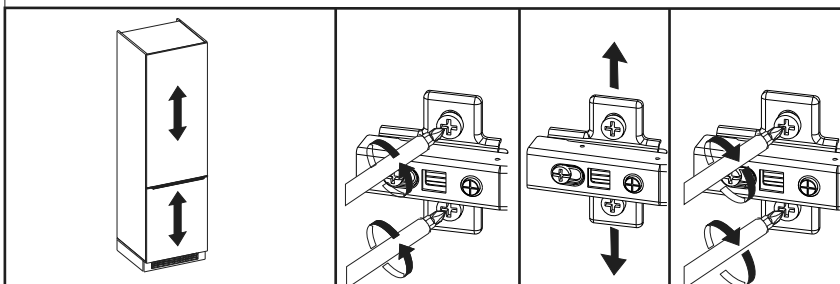
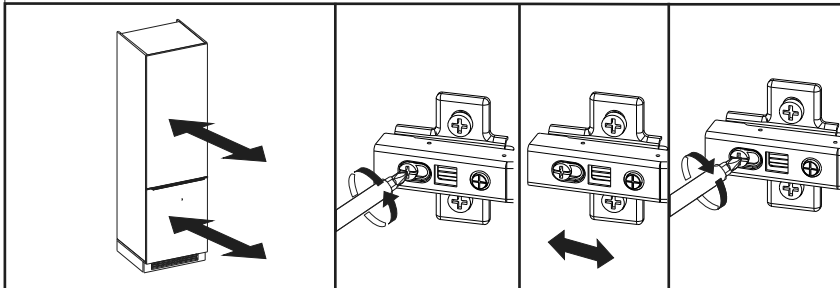
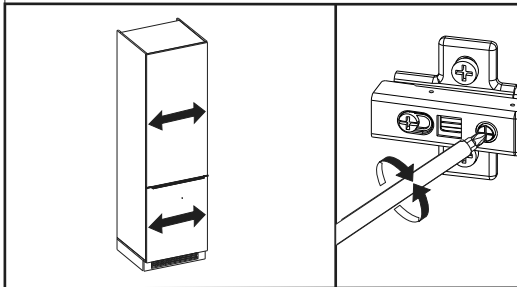
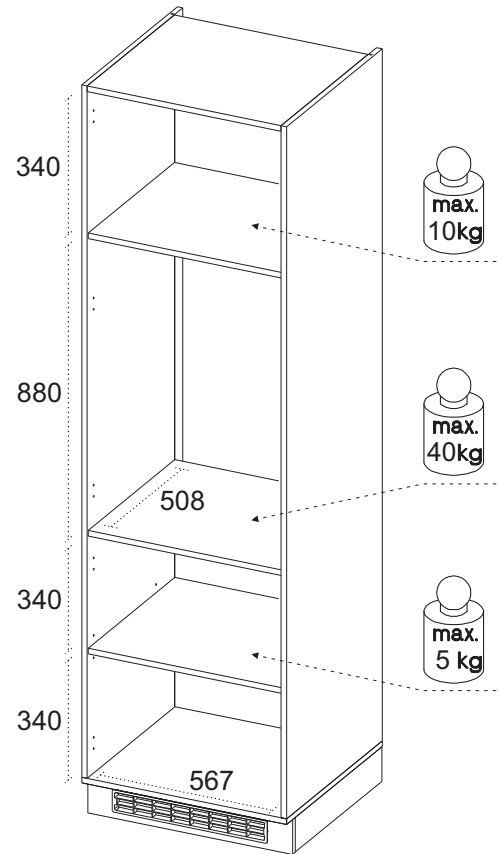
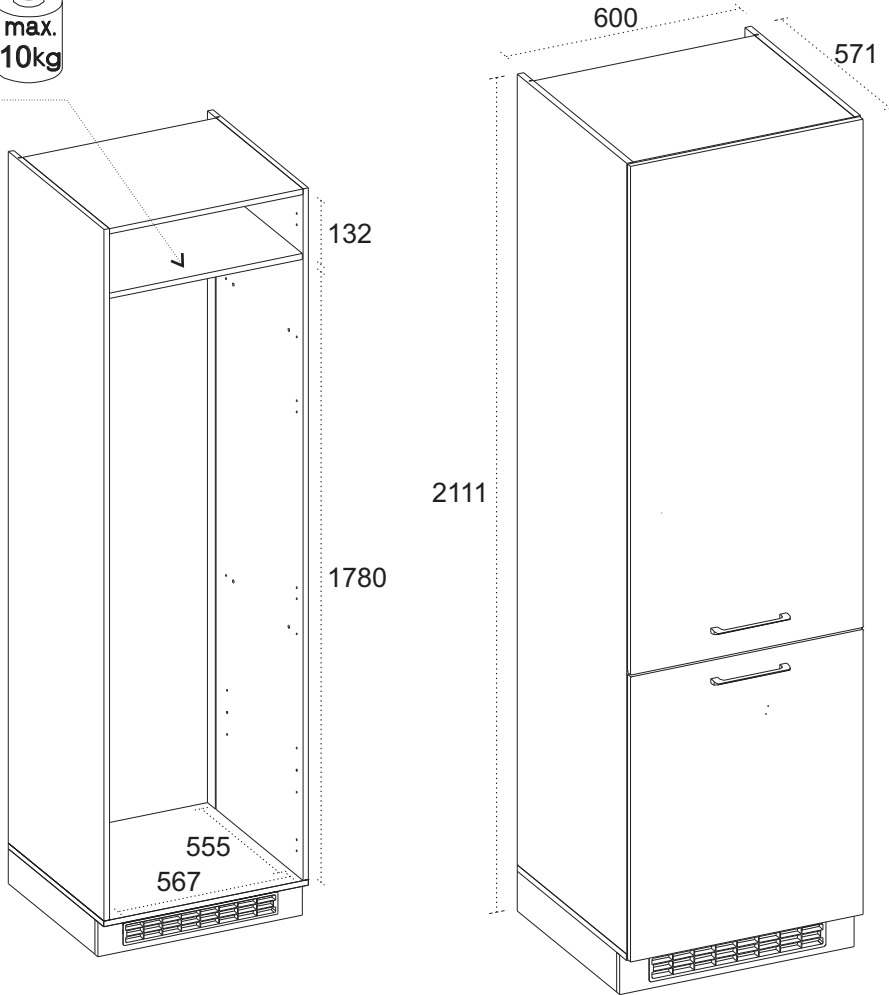
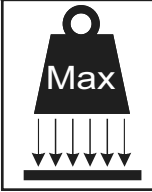

Allgemeine Hinweise

Die Montage einer Einbauküche sollte von entsprechend geschulten Fachkräften durchgeführt werden. Vor der Montage müssen die Montagehinweise gelesen werden.

Spezielle, weiterführende Montageanleitungen und Hinweise liegen den Geräten, Spülen, Beleuchtungen und Sonderausstattungen bei und müssen zusätzlich beachtet werden.

Für die Befestigung von Wandhängeelemente gilt:

Wir legen kein Befestigungsmaterial bei. Bitte prüfen Sie die gegebene Wandbeschaffenheit und wenden Sie sich an den örtlichen Fachhandel zum Erwerb der passenden Dübel / Haken / Aufhängeschienen / Schrauben

Für die Aufhängung können entweder Haken oder Aufhängeschienen verwendet werden.

Die Hängeschränke können bei korrekter Montage mit ca. 40 kg belastet werden. Achten Sie auf eine gleichmäßige Lastverteilung

Bei Nichtbeachtung der Montagehinweise können wir entstandene Schäden keine Haftung übernehmen

Achten Sie darauf bei Einzelschränken, oder der gesamten Küchenzeile eine Kippsicherung anzubringen

Sanitär- und Elektroinstallationen dürfen nur von einer entsprechenden Fachkraft vorgenommen werden

Vor Bohrarbeiten muss geprüft werden, dass an der Stelle des Bohrens keine Leitungen für Gas, Wasser, Strom, Heizun

Abflüsse verlegt wurden

Es dürfen keine verändernden Manipulationen am Zubehör oder an Elektrogeräten vorgenommen werden. Dies gilt insbesondere für Befestigungsbohrungen.

Überprüfen Sie vor der Montage ob alle Anschlüsse vorhanden sind und fachgerecht ausgeführt wurden

Die Küche beinhaltet verschluckbare Kleinteile. Kinder unter 3 Jahre nicht ohne Beaufsichtigung lassen

Empfohlenes Vorgehen bei der Küchenmontage:

Planen Sie den genauen Montageort unter Berücksichtigung Ihrer Sanitär- und Elektroanschlüsse
Prüfen Sie ob Ihr Kühl- Gefriergerät Lüftungsauslässe im Sockelbereich bzw. im Bereich der Arbeitsplatte benötigt
Erwerben Sie ggf. passende Lüftungsgitter im Fachhandel und schneiden Sie den Sockel bzw. die Arbeitsplatten gemäß den Anweisungen des Geräteherstellers aus.
Legen Sie fest, ob Sie die Türen mit Rechts- oder Linksanschlag montieren wollen

Montieren Sie zunächst die Unterschränke und richten Sie diese mit einer Wasserwaage aus.

Erst wenn alles exakt steht, verbinden Sie die einzelnen Schränke mit Schrauben. Damit dabei nichts verrutscht, empfehlen wir Ihnen dringend den Einsatz von zwei Schraubzwingen. Die Schrankoberflächen schützen Sie mit Zulagehölzern vor Eindrücken.

Ermitteln Sie durch exaktes Messen die Positionen der Bohrungen für die Hängebeschläge

Legen Sie die Arbeitsplatte auf die Korpusse, richten Sie sie aus, und fixieren Sie sie mit Zwingen. markieren Sie die Lage und -breite des Herdunterschrankes.

Auf der Unterseite der Arbeitsplatte reißen Sie im markierten Bereich den Herdplattenausschnitt auf. Mitteln Sie sie aus, so dass die Spüle mittig im Unterschrank sitzt und vorne und hinten die Plattenrestbreite gleich wird.

Empfohlenes Vorgehen bei der Küchenmontage:

Bohren Sie in den vier Ecken jeweils ein 10-mm-Loch zum leichteren Einsetzen der Stichsäge, und schneiden Sie den Herdausschnitt entlang Ihrer Risse aus. Arbeiten Sie immer von der Plattenunterseite, damit die Plattenoberfläche durch die Stichsäge nicht ausfasert. Schalten Sie dazu auch den Pendelhub an Ihrer Stichsäge, sofern vorhanden, aus.
Zum Schutz der Holzteile können Sie rundum die Sockelteile eine Silikonnaht ziehen

Empfohlenes Vorgehen bei der Küchenmontage:

Bohren Sie in den vier Ecken jeweils ein 10-mm-Loch zum leichteren Einsetzen der Stichsäge, und schneiden Sie den Herdausschnitt entlang Ihrer Risse aus. Arbeiten Sie immer von der Plattenunterseite, damit die Plattenoberfläche durch die Stichsäge nicht ausfasert. Schalten Sie dazu auch den Pendelhub an Ihrer Stichsäge, sofern vorhanden, aus.
Zum Schutz der Holzteile können Sie rundum die Sockelteile eine Silikonnaht ziehen

DE	<p>Warnhinweis: Wenn der Ware Dübel und Schrauben beiliegen, sind sie ausschließlich zur Anwendung an Wänden aus massiven und einheitlichen Materialien bestimmt, um ein Umkippen zu verhindern. Vergewissern Sie sich vor dem Bohren, dass sich keine Gas-, Wasser-, oder Stromleitungen an der Bohrstelle befinden. Zur Befestigung an anderen Wänden müssen Spezialdübel verwendet werden. Erkundigen Sie sich im Handel nach den für die jeweilige Wandbeschaffenheit geeigneten Schrauben und oder Dübel. Für eine unsachgemäße Montage und dadurch entstandene Schäden übernimmt der Hersteller keine Haftung. Bitte alle Schrauben in regelmäßigen Abständen überprüfen und nachziehen.</p>
FR	<p>Avertissement : Pour éviter le basculement accidentel du meuble, la fixation du meuble au mur est obligatoire. Si des chevilles et des vis sont fournies avec l'article, elles sont exclusivement destinées à être utilisées sur des murs en matériaux massifs et homogènes pour éviter tout basculement. Avant de percer, assurez-vous qu'aucune conduite de gaz, d'eau ou d'électricité ne se trouve à l'endroit où vous percez. Pour la fixation sur d'autres murs, il faut utiliser des chevilles spéciales. Renseignez-vous en magasin sur les vis et les chevilles adaptées à chaque type de mur. Le fabricant décline toute responsabilité en cas de montage incorrect et de dommages qui en résulteraient. Veuillez vérifier et resserrer toutes les vis à intervalles réguliers. ATTENTION ! Les meubles contenant des panneaux à base de bois (panneaux de particules, panneaux de fibres, contreplaqué...) peuvent émettre des substances polluantes dans l'air intérieur. Il est ainsi recommandé, après l'installation du meuble dans son logement, d'aérer fréquemment la pièce concernée pendant au moins quatre semaines afin de réduire son exposition aux polluants émis par le meuble LED: Ce luminaire est un produit de décoration. Ce luminaire ne convient pas pour l'éclairage principal d'une pièce de la maison.</p>
UK	<p>Warning: If dowels and screws are included with the product, they are only intended for use on walls made of solid and uniform materials to prevent them from tipping over. Before drilling, make sure that there are no gas, water or electricity pipes at the drilling site. Special anchors must be used for fastening to other walls. Ask in the trade for the screws and or dowels suitable for the respective wall condition. The manufacturer accepts no liability for improper installation and any resulting damage. Please check and retighten all screws at regular intervals.</p>
IT	<p>Avvertenza: Se con il prodotto sono forniti tasselli e viti, questi sono destinati esclusivamente all'utilizzo su pareti realizzate con materiali solidi ed uniformi, per evitare il ribaltamento. Prima di eseguire i fori assicurarsi che non ci siano condutture di gas, acqua o elettriche vicino al punto di perforazione. Per il fissaggio ad altre pareti è necessario utilizzare tasselli speciali. Chiedere al proprio rivenditore le viti e/o tasselli adatti al tipo di parete in questione. Il produttore non si assume alcuna responsabilità in caso di montaggio improprio e dei danni che ne derivano. Controllare e serrare tutte le viti a distanza regolare.</p>
PL	<p>Ostrzeżenie: Jeżeli do towaru dołączone są kołki i śruby, są one przeznaczone wyłącznie do stosowania na ścianach wykonanych z solidnych i jednolitych materiałów, aby zapobiec przewróceniu. Przed rozpoczęciem wiercenia należy upewnić się, że w miejscu wiercenia nie są ułożone rury gazowe, wodociągowe lub przewody elektryczne. Do mocowania do innych ścian należy stosować kołki specjalne. O śruby lub kołki odpowiednie dla konstrukcji danej ściany należy pytać w sklepach specjalistycznych. Producent nie ponosi odpowiedzialności za nieprawidłowy montaż i wyniki z tego tytułu szkody. Wszystkie śruby należy regularnie sprawdzać i dokręcać.</p>
ESP	<p>Advertencia: En el caso de incluirse tacos y tornillos con la mercancía, estos están previstos únicamente para su uso en paredes macizas y homogéneas a fin de evitar un posible vuelco. Antes de taladrar, asegúrese de que por el punto de perforación no pasan tuberías de gas o agua o cables eléctricos. Para la fijación en otro tipo de paredes deben utilizarse tacos especiales. Pregunte en la tienda por los tornillos o tacos adecuados para las características de la pared en cuestión. El fabricante no asume ninguna responsabilidad por un montaje incorrecto ni por los daños resultantes del mismo. Compruebe todos los tornillos en intervalos regulares y apriételes.</p>
CZ	<p>Výstražné upozornění: Pokud jsou k výrobku přiloženy hmoždinky a šrouby, jsou určeny výhradně pro použití do stěn zhotovených z masivních a homogenních materiálů, a to za účelem zajištění proti převrácení. Před vrtáním se ujistěte, že se v místě vrtání nenachází vedení plynu, vody nebo elektřiny. Pro připevnění k jiným stěnám je nutné použít speciální hmoždinky. Informujte se v obchodě o hmoždinkách a/nebo šroubech vhodných pro příslušnou strukturu stěny. Výrobce nenese odpovědnost za nesprávnou montáž a za škody jí způsobené. Všechny šrouby pravidelně kontrolujte a dotahujte.</p>
SK	<p>Informácia o nebezpečenstve: Ak sú k tovaru priložené príchytky a skrutky, sú určené výlučne na použitie na stenách z masívnych a jednotných materiálov, aby sa zabránilo prevráteniu. Pred vrtaním sa uistite, že sa na vrtanom mieste nenachádzajú žiadne plynové, vodovodné alebo elektrické vedenia. Na upevnenie na iných stenách musia byť použité špeciálne príchytky. Spýtajte sa v predajni na skrutky a/alebo príchytky vhodné pre príslušný typ steny. Výrobca nepreberá ručenie za nesprávnu montáž a tým vzniknuté škody. Všetky skrutky v pravidelných intervaloch kontrolujte a dotiahnite.</p>
HU	<p>Figyelmeztetés: Amennyiben a termék csomagolásába tipliket és csavarokat is tartalmaz, azok kizárólag masszív, egységes anyagból készült falakon használhatók, a felborulás megakadályozásának céljából. A fúrás előtt bizonyosodjon meg arról, hogy a fúrás helyén nem található gáz-, víz- vagy elektromos vezeték. Egyéb falakra történő rögzítéshez speciális tiplik szükségesek. Az egyes faltípusokkal használható megfelelő csavarokkal és/vagy tiplikkel kapcsolatos információkért kérjük, forduljon forgalmazójához. A nem szakszerű szerelésért és az abból keletkező károkért a gyártót semmilyen felelősség nem terheli. Minden csavart ellenőrizzen és rögzítsen rendszeresen.</p>
BG	<p>Предупредително указание: Ако в окомплектовката на доставката на стоката са включени дюбели и винтове, те са предназначени единствено за употреба върху стени от масивни и еднородни материали, за да се предотврати преобръщане. Преди пробиване се уверете, че на мястото на пробиване няма тръби за газ, за вода или електрически проводници. За закрепване към други стени трябва да се използват специални дюбели. Информирайте се в търговската мрежа относно подходящите винтове и/или дюбели за съответната конструкция на стената. Производителят не поема отговорност за неправилен монтаж и възникнали в резултат на това щети. Моля, проверявайте и затягвайте всички винтове на редовни интервали.</p>
TR	<p>Uyarı: Ürün paketinde dübel ve vida varsa, bunlar devrilmeyi önlemek amacıyla, sadece masif ve yekpare malzemelerden imal edilmiş duvarlardaki kullanım için öngörülmüştür. Matkapla delik açmadan önce delme noktasında gaz, su veya elektrik hatlarının olmadığından emin olun. Ürünü başka duvarlara sabitlemek için özel dübeller kullanılmalıdır. Piyasadaki satıcılardan ilgili duvarın özelliğine uygun vidalar ve dübeller hakkında bilgi alın. Usulüne aykırı bir montaj ve bu nedenle oluşmuş hasarlar için üretici sorumluluk almamaktadır. Lütfen tüm vidaları düzenli aralıklarla kontrol edip tekrar sıkın.</p>

PT	Advertência: Caso o produto venha com buchas e parafusos incluídos, os mesmos são exclusivamente destinados à fixação em paredes de materiais sólidos e uniformes, para evitar que o produto tombe. Antes de iniciar a perfuração, certifique-se de que não existem canalizações de gás, água ou fios elétricos a passar no local dos furos. Para a fixação noutro tipo de paredes, têm de ser utilizadas buchas especiais. Informe-se junto de um comerciante especializado sobre os parafusos e buchas a utilizar na parede específica. O fabricante não assume qualquer responsabilidade no caso de uma montagem inadequada e qualquer dano daí resultante. Verifique e volte a apertar todos os parafusos regularmente.
SI	Opozorilo: če so blagu priloženi zidni vložki in vijaki, so ti namenjeni izključno za uporabo na stenah iz masivnih in enotnih materialov, da se prepreči prevrnitev. Pred vrtnanjem se prepričajte, da na mestu vrtnanja ni plinskih, vodnih ali električnih napeljav. Za pritrditev na druge stene je treba uporabljati posebne zidne vložke. Pozanimajte se v trgovini o vijakih in/ali zidnih vložkih, primernih za posamezno sestavo stene. Proizvajalec ne prevzema jamstva za nepravilno montažo in zaradi tega nastalo škodo. Vse vijake redno preverjajte in naknadno privijajte.
NL	Waarschuwing: Indien er bij het product pluggen en schroeven zijn meegeleverd, zijn deze uitsluitend bestemd om in muren van massieve en homogene materialen te gebruiken om te voorkomen dat het product kantelt. Controleer voordat u begint of er geen gas-, water- of elektriciteitsleidingen lopen waar u gaat boren. Voor de bevestiging aan andere soorten muren moeten speciale pluggen worden gebruikt. Informeer in de winkel welke schroeven en/of pluggen geschikt zijn voor de desbetreffende muur. De fabrikant is niet aansprakelijk voor een onjuiste montage en de daardoor ontstane schade. Controleer regelmatig of alle schroeven nog goed vastzitten en draai ze zo nodig vast.
SRB	Upozoravajuća napomena: Ako su uz robu priloženi tiplovi i zavrtnji, isti su namenjeni isključivo za primenu na zidovima od kompaktnih i homogenih materijala, kako bi se sprečilo prevrtanje. Pre bušenja se uverite da se na mestu bušenja ne nalaze vodovi za gas, vodu ili struju. Za fiksiranje na drugačijim zidovima moraju da se upotrebe specijalni tiplovi. Raspitajte se u trgovini o zavrtnjima i/ili tiplovima koji su adekvatni za dotičnu teksturu zida. Proizvođač ne preuzima nikakvu odgovornost za nestručnu montažu i štete koje su nastale na taj način. Sve zavrtnje kontrolišite i dotežite u redovnim intervalima.
RO	Indicație de avertizare: Dacă produsul este livrat împreună cu șuruburi și dibluri, acestea sunt destinate exclusiv utilizării pe pereți construiți din materiale masive și uniforme, pentru a preveni răsturnarea produsului. Înainte de a realiza găurile, asigurați-vă că nu există conducte de gaz, apă sau electricitate în locul pe care doriți să-l găuriți. Pentru prinderea pe alte tipuri de pereți, trebuie să utilizați dibluri speciale. Interesați-vă la magazinul specializat, pentru a găsi șuruburile și/sau diblurile potrivite pentru peretele dvs. Producătorul nu este responsabil, în cazul unui montaj necorespunzător pentru daunele rezultate. Vă rugăm să verificați toate șuruburile la intervale regulate și să le strângeți.
HR	Upozorenje: Ako su uz proizvod priložene tiple i vijci, oni su namijenjeni isključivo za korištenje na zidovima od čvrstih i jednoličnih materijala kako bi se spriječilo prevrtanje. Prije bušenja provjerite da na mjestu bušenja nema električnih vodova, plinskih ili vodovodnih cijevi. Za pričvršćivanje na ostale zidove potrebno je koristiti posebne tiple. Prilikom kupnje raspitajte se kod svog prodavača o vijcima i tiplama koji su prikladni za odgovarajuću zidnu strukturu. Proizvođač ne odgovara za štete nastale uslijed nepravilne montaže. Sve vijke potrebno je redovito provjeravati i zategnuti.
SE	Varning: Om plugg och skruvar följer med produkten är de endast avsedda för väggar av massivt och enhetligt material för att förhindra att produkten vippar. Försäkra dig om att inga gas-, vatten- eller elledningar befinner sig på platsen som du ska borra innan du börjar. För fastsättning i väggen måste specialplugg användas. Informera dig i en butik om vilka skruvar och plugg som passar till vilken vägg. För en felaktig montering och skador som uppstår på grund av detta tar tillverkaren inget ansvar. Kontrollera och dra åt alla skruvar med jämna mellanrum.
RUS	Предупреждение: Если изделие поставляется вместе с дюбелями и шурупам, они предназначены исключительно для использования на стенах из монолитных и однородных материалов, чтобы предотвратить возможное обрушение. Перед началом сверления убедитесь, что на месте сверления нет газопровода, водопровода или электропроводки. Для крепления к другим стенам необходимо использовать специальные дюбели. Узнайте у продавца, какие шурупы или дюбели подходят для соответствующей структуры стены. Производитель не несет ответственности за неправильный монтаж и вызванный им ущерб. Регулярно проверяйте и подтягивайте все шурупы.
UKR	Попередження: Якщо до виробу додаються дюбелі та гвинти, вони призначені виключно для використання на стінах з цільних й однорідних матеріалів, щоб не допустити перекидання. Перед свердлінням переконайтеся, що на місці свердління немає ліній газо-, водопостачання чи електропроводки. Для кріплення до інших стін необхідно використовувати спеціальні дюбелі. Запитайте продавця, які гвинти та/або дюбелі підходять для стіни з відповідною структурою. Виробник не несе відповідальності за неправильний монтаж та збитки, що виникли внаслідок цього. Перевіряйте та підтягуйте всі гвинти через регулярні проміжки часу.
LT	Įspėjimas: jei prie prekės pridėtos mūrvinės ir varžtai, jie skirti naudoti tik ant sienų, pagamintų iš tvirtų ir vienujų medžiagų, kad būtų galima išvengti apvirtimo. Prieš gręždami įsitinkite, kad gręžiamoje vietoje nėra dujotiekio, vandentiekio ar elektros linijų. Tvirtinant prie kito tipo sienų reikia naudoti specialias mūrvines. Teiraukitės pardavėjo atitinkamai sienos konstrukcijai tinkamų varžtų ir (arba) mūrvinių. Gamintojas neprisiima atsakomybės dėl netinkamo montavimo ir dėl to atsiradusios žalos. Visus varžtus reguliariai tikrinkite ir priveržkite.
LV	Brīdinājums: Ja precei ir pievienoti dībeļi un skrūves, prece ir paredzēta izmantošanai tikai uz sienām, kas izgatavotas no cietiem un viendabīgiem materiāliem, lai novērstu apgāšanos. Pirms urbšanas pārlicinieties, ka urbšanas vietā nav gāzes, ūdens vai elektropārvades līniju. Lai piestiprinātu pie citām sienām, jāizmanto speciāli dībeļi. Jautājiet savam izplatītājam par skrūvēm un/vai dībeļiem, kas ir piemēroti attiecīgajai sienas konstrukcijai. Ražotājs neuzņemas atbildību par nepareizu montāžu un no tās sekojošajiem bojājumiem. Lūdzu, regulāri pārbaudiet un pievelciet visas skrūves.
EE	Hoiatus! Kui tootele on kaasa pandud tüüblid ja kruvid, on need mõeldud kasutamiseks üksnes massiivsest ja ühtsest materjalist seintel, vältimaks ümberkukkumist. Veenduge enne puurimist, et puurimiskohas ei oleks gaasi- või veetorusid ega elektrijuhtmeid. Seintele kinnitamiseks tuleb kasutada spetsiaalseid tüüpleid. Uurige kaubandusvõrgust, millised kruvid ja/või tüüblid konkreetselt seinale sobivad. Tootja ei võta endale mittenõuetekohasest paigaldamisest tingitud kahjude eest mingit vastutust. Kontrollige ja järelpingutage kõiki kruvisid regulaarselt.



**LE TRI
+ FACILE**



FR

**Donnez ou recyclez
vos meubles.**



Association



Magasin



Déchèterie

<https://quefairedemesdechets.fr>

TURIN BKS 60

73/004/..



„MEBLE-OKMED” DEMKO - SPÓŁKA JAWNA
ul. Kolejowa 13, 14-500 Braniewo, POLSKA
(+48) 55 243 27 26

ZP: .../...

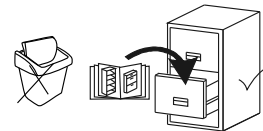

TURIN
BKS 60
ZP:/..



600

571

2111

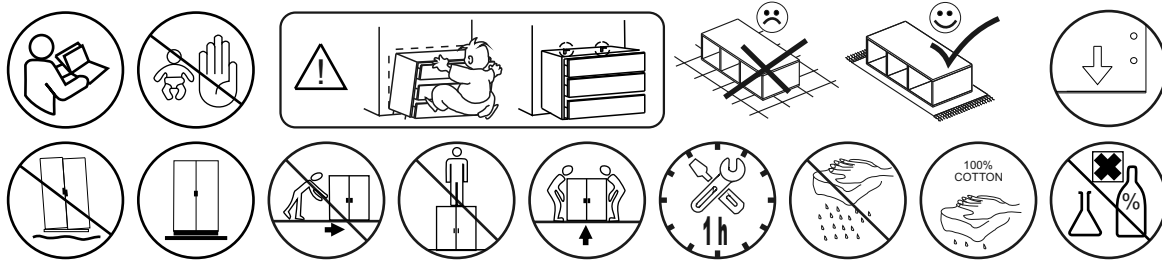
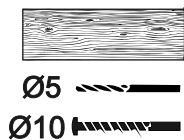
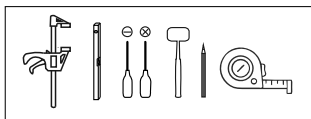
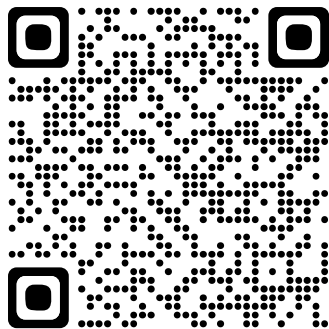
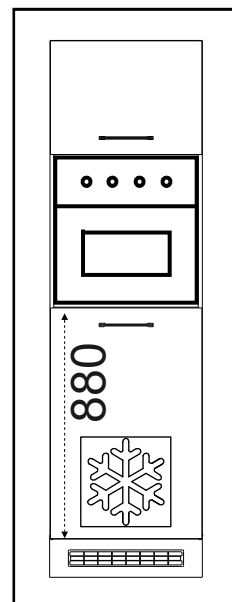
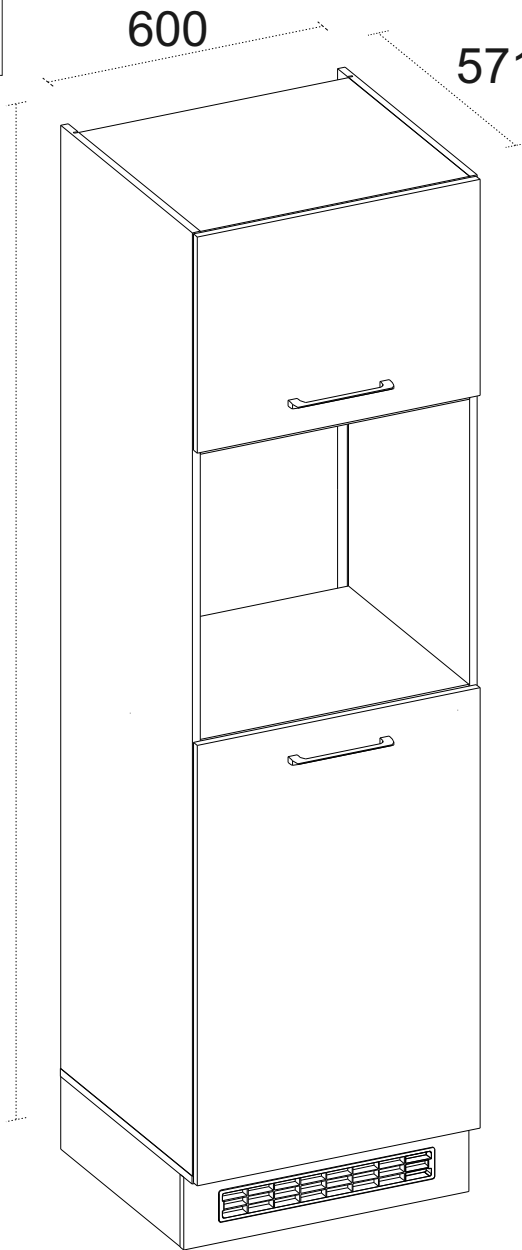



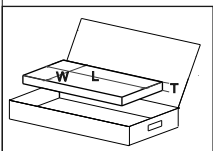

N	L [mm]	W [mm]	T [mm]	Q	COLLI
1	908	596	16	1	COLLI_1
2	446	596	16	1	COLLI_1
3	583	455	3	1	COLLI_1
6	504	150	16	2	COLLI_1
7	600	150	16	1	COLLI_1
8	600	555	16	1	COLLI_1
4	1945	555	16	1	COLLI_2
5	1945	555	16	1	COLLI_2
9	567	508	16	1	COLLI_2
10	567	508	16	1	COLLI_2
11	567	508	16	1	COLLI_2

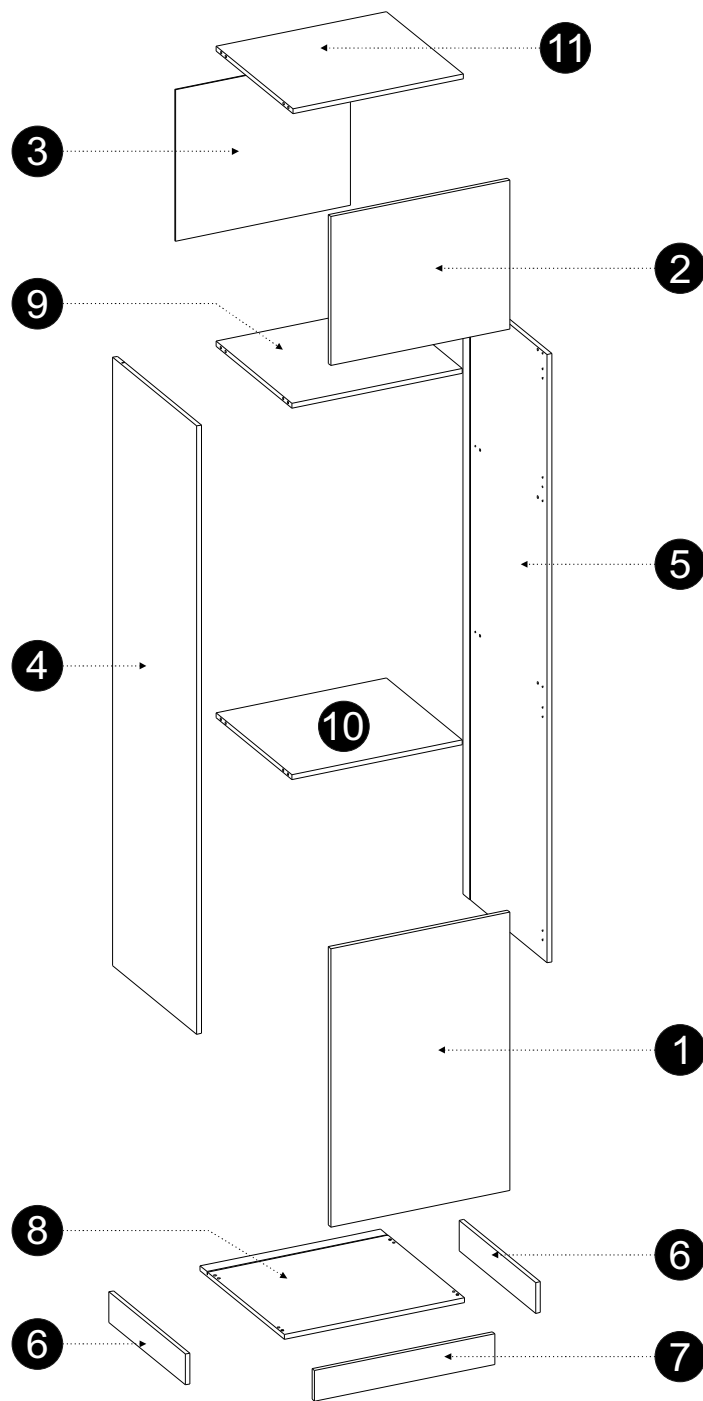

	COLI_1_2
	COLI_1_2

	1		
3,5x25 	4		1
	1		2
4x13 	8	3x16 	10
	8		10
	12		12
	12	10x50 	2
	12	6x50 	2
	8		4
	8	6,4x50 	4
	4		4
	4		6
	4		6
Ø8x35 	16	3,5x16 	32
	16		2



		
ZM1B	KT1	ZM1A
12	16	12

Ø8x35

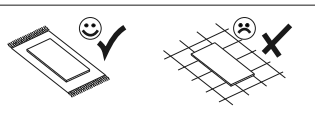
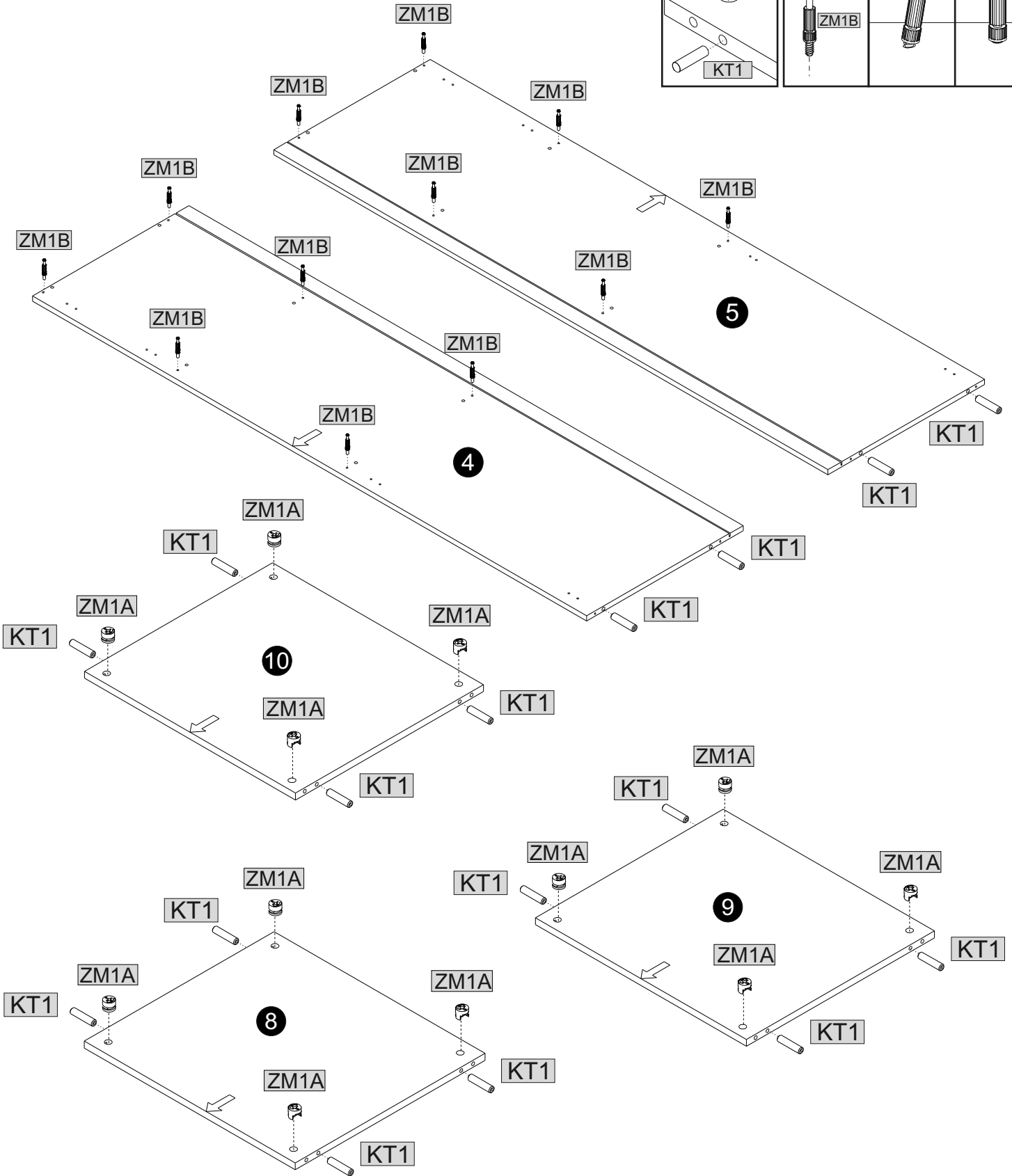
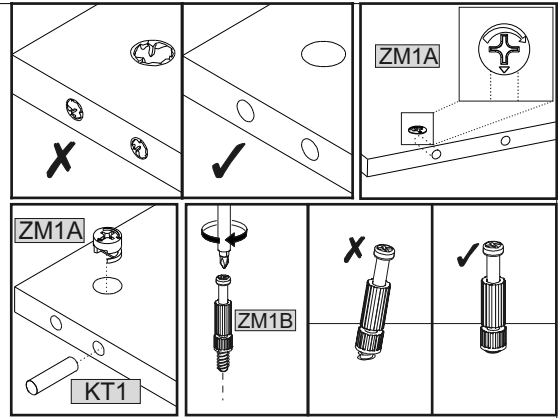

02

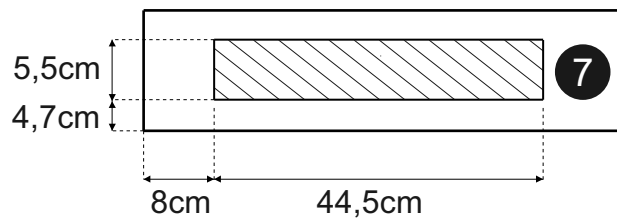
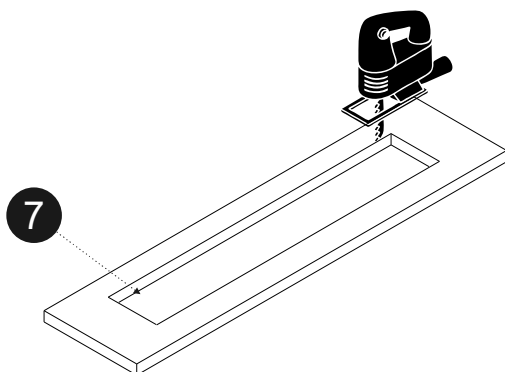
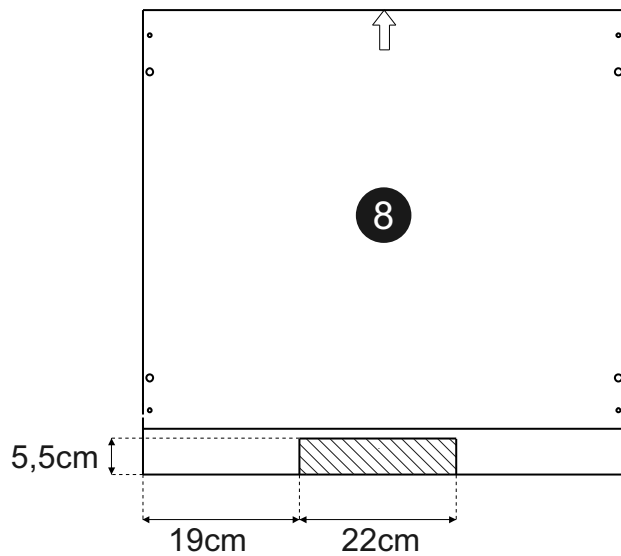
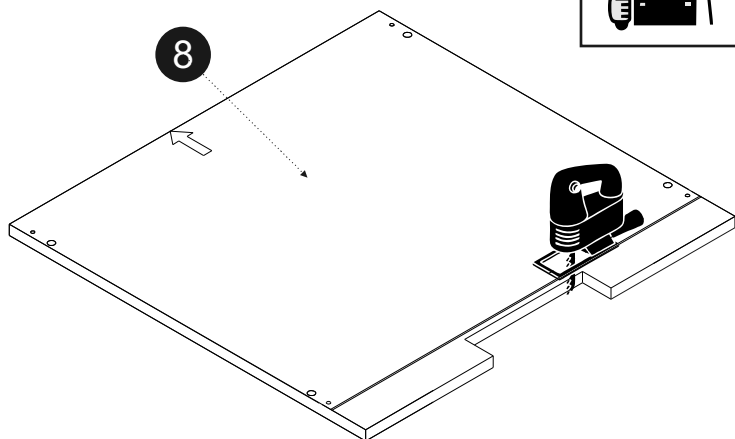
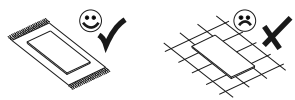

03

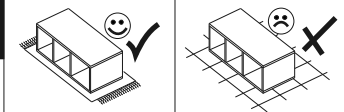

KK1 1

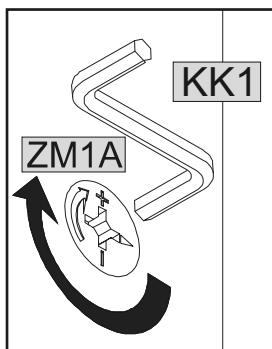
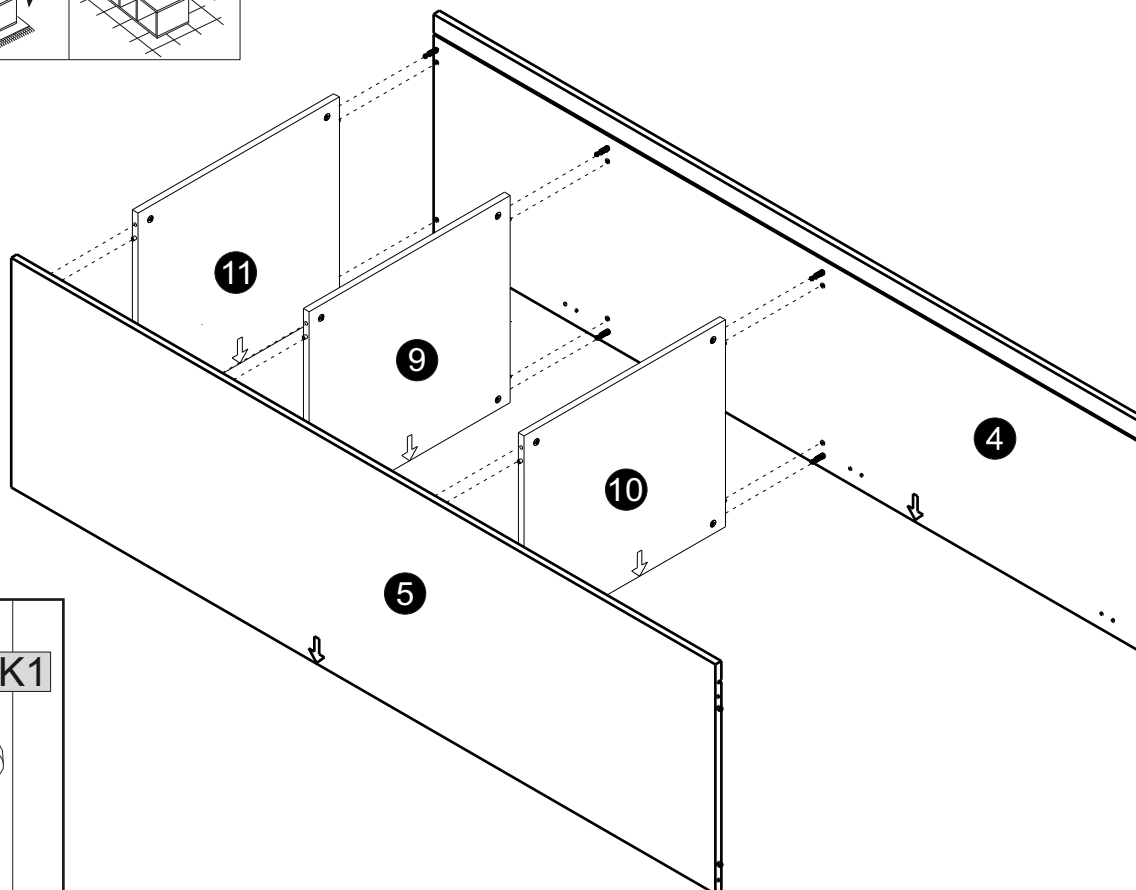

04

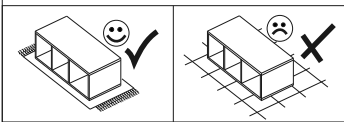
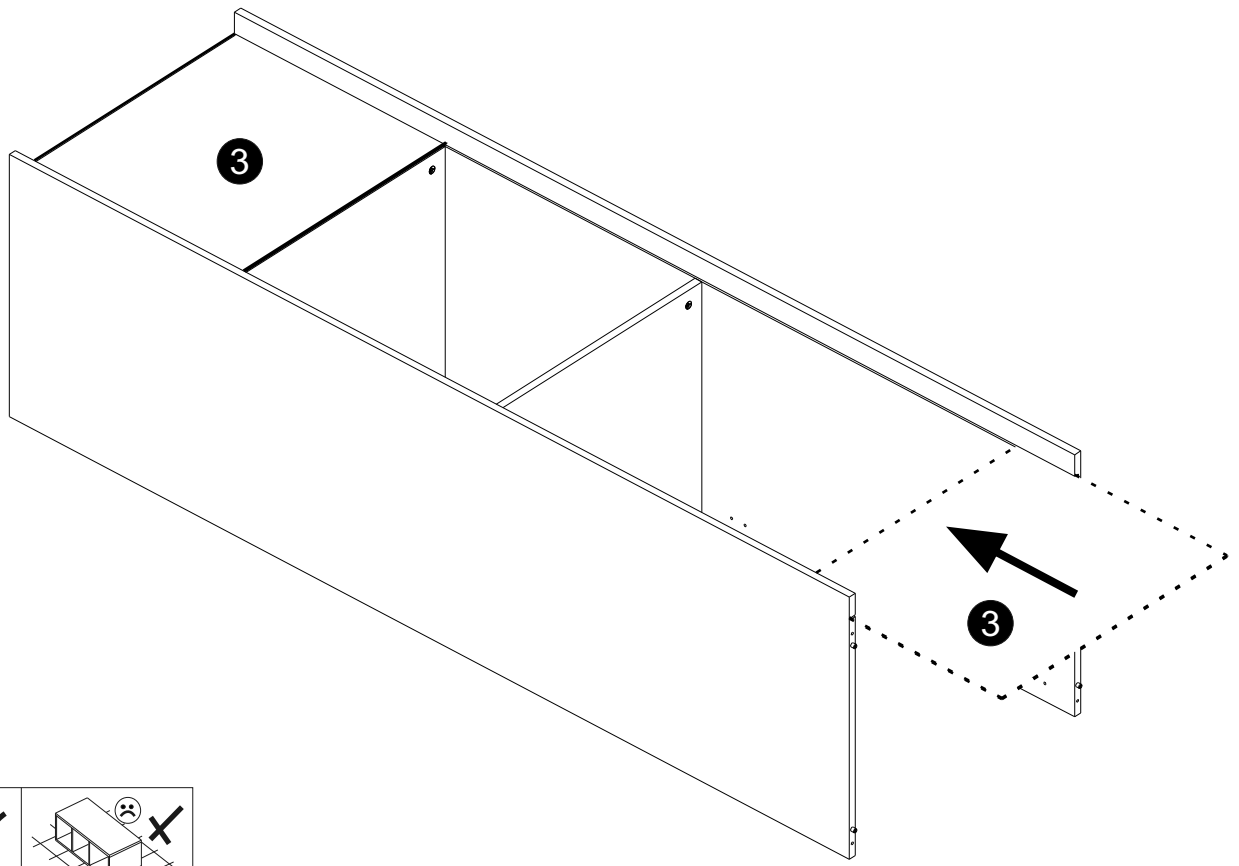

05

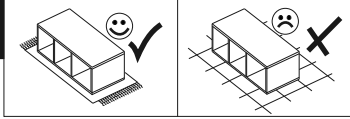

	1		4
		6,4x50	

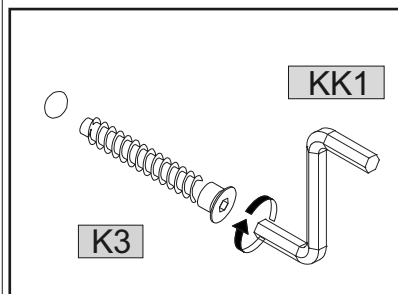
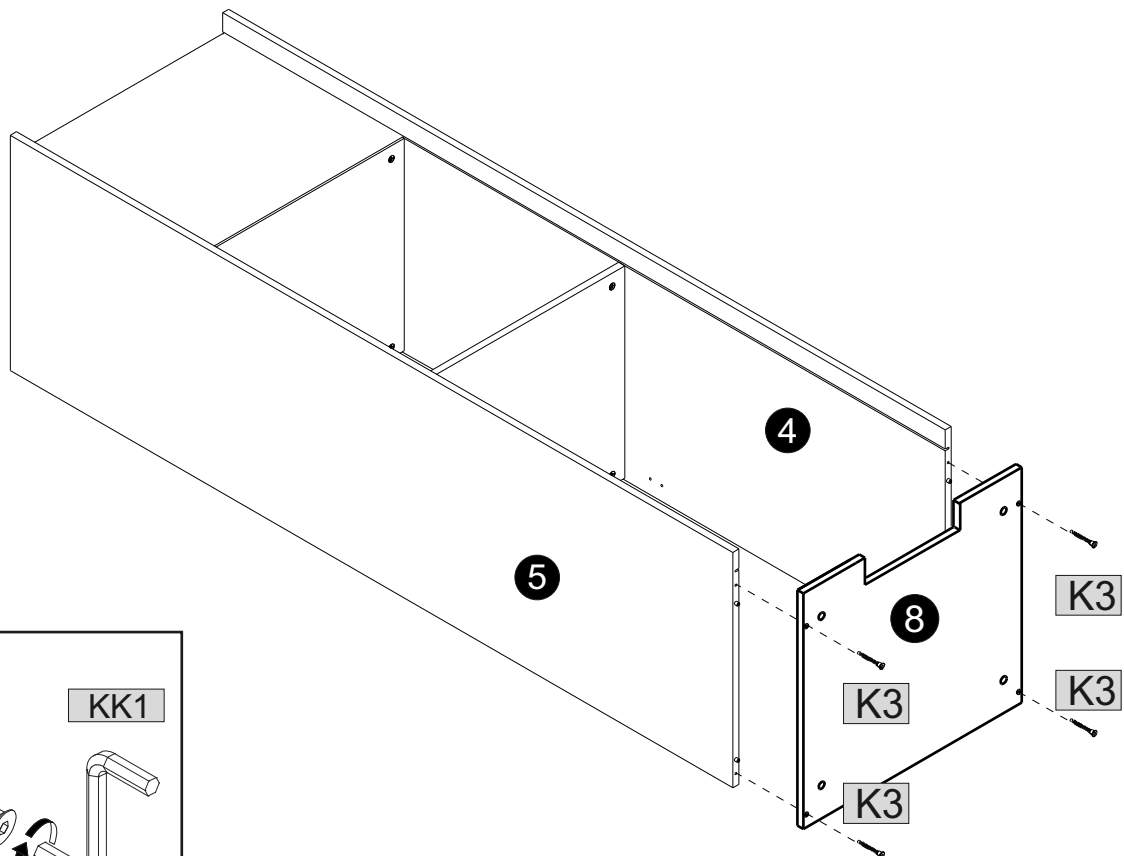

06



S1

4



W1

3x16

10

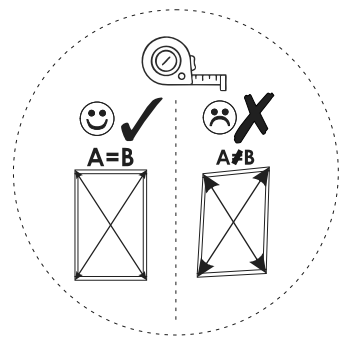
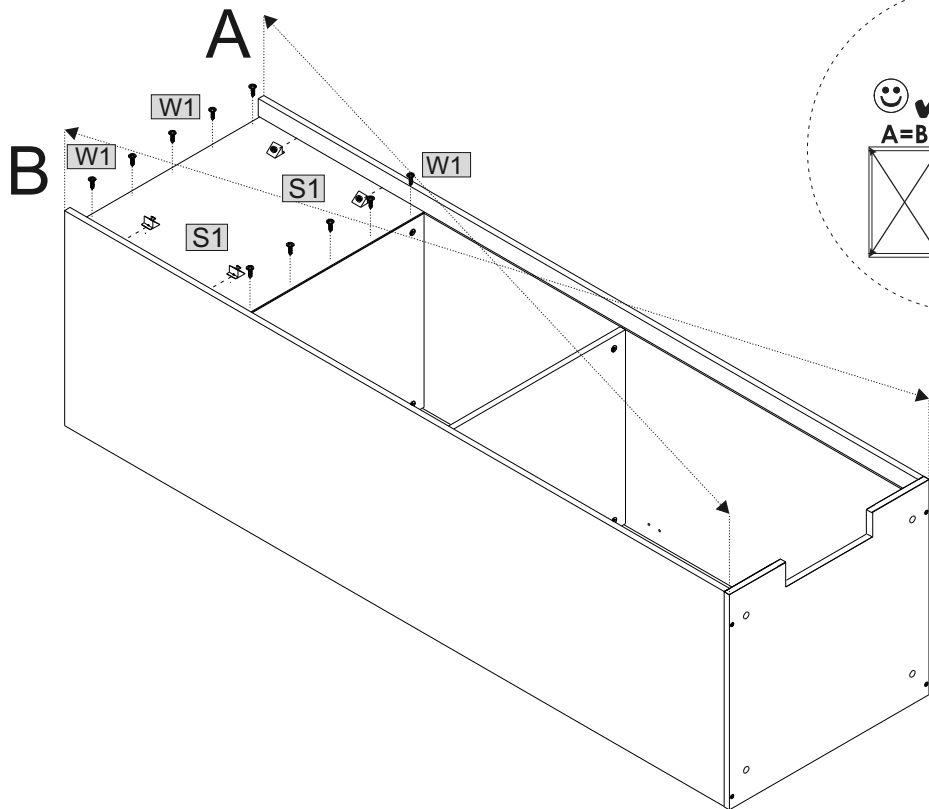
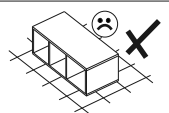
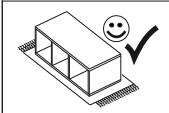
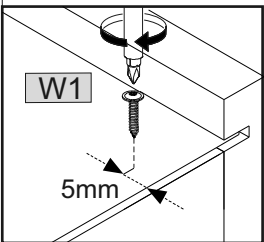
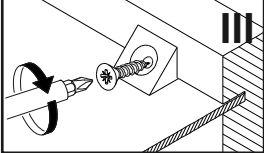
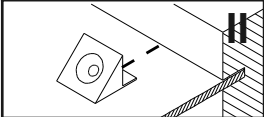
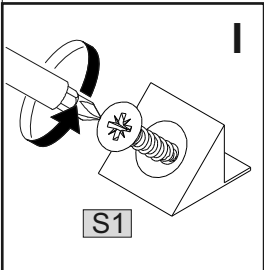

07



W11

3,5x16

16

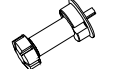

NK1

4

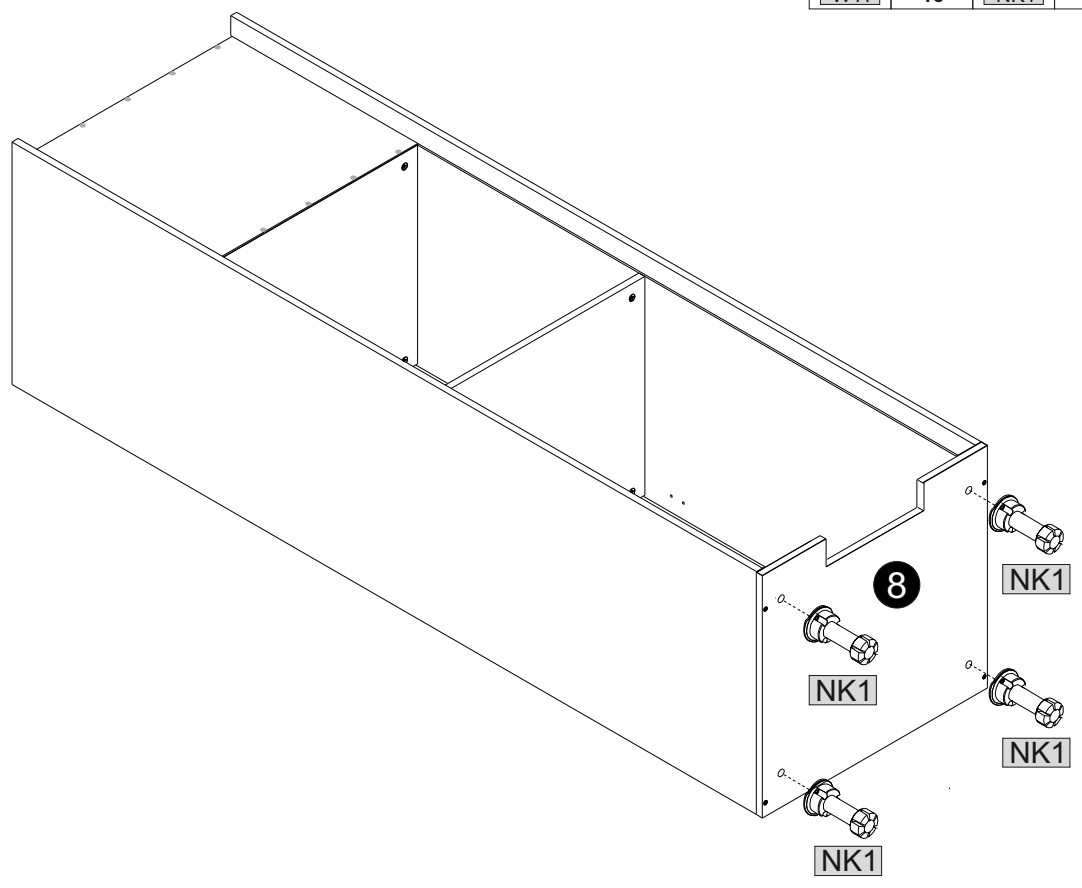
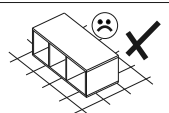
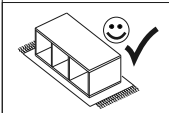
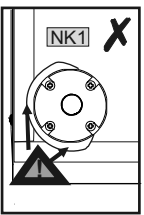
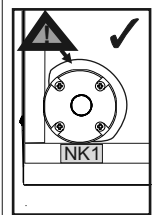
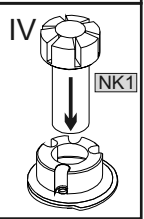
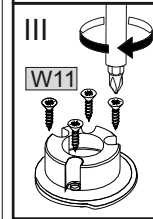
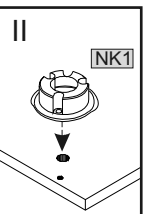
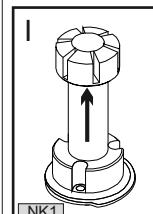

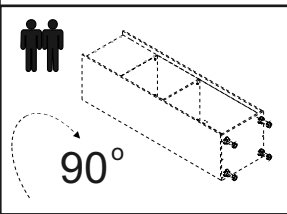

	10x50		6x50		3,5x16		
KRW1	2	KRL1	2	W11	4	KS1	2

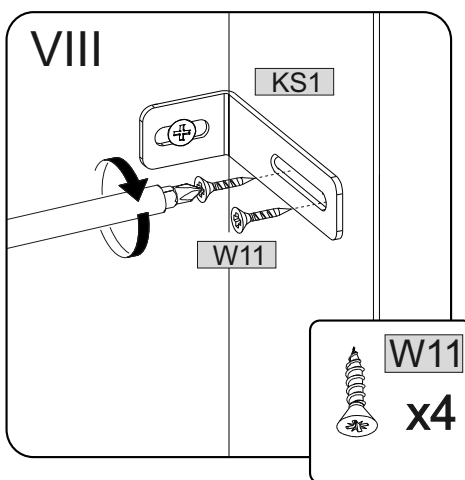
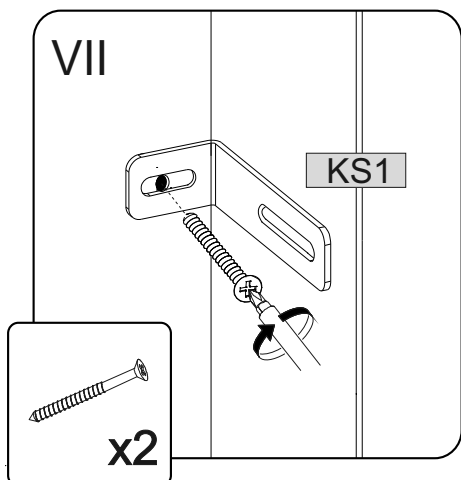
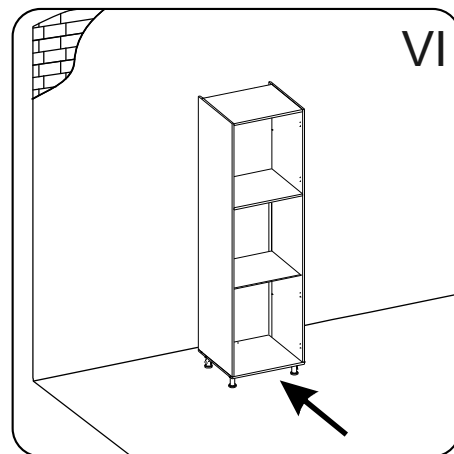
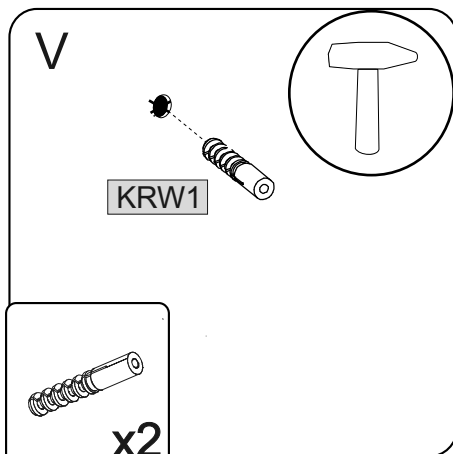
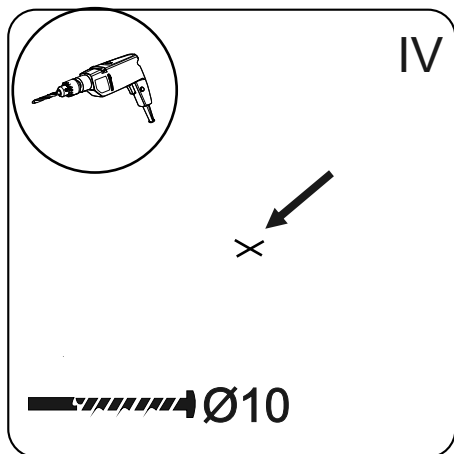
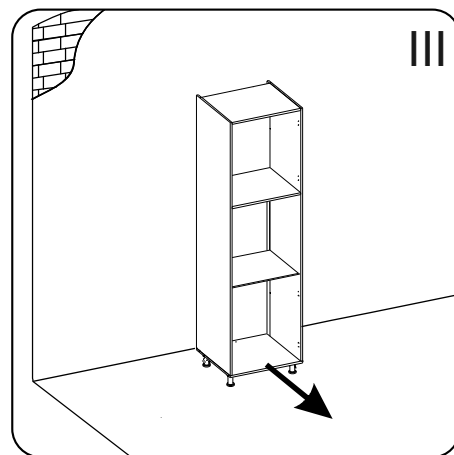
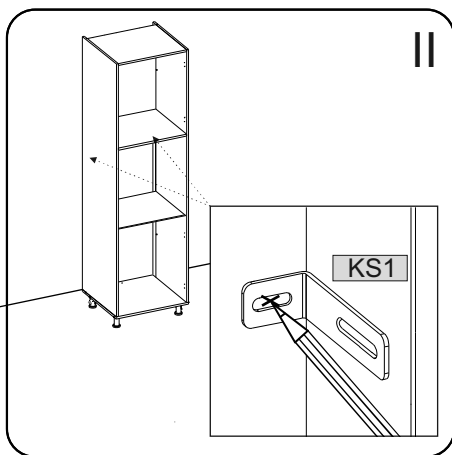
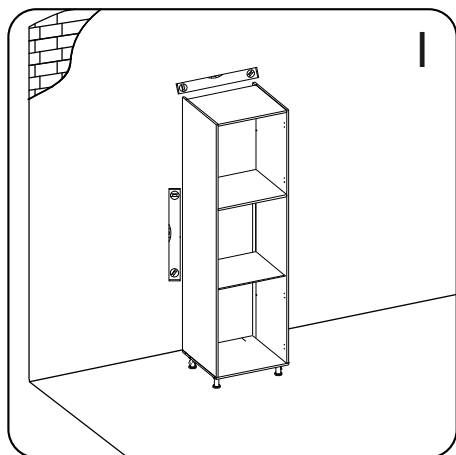

09

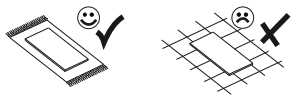

	4x13		
W4	8	ZPH	4

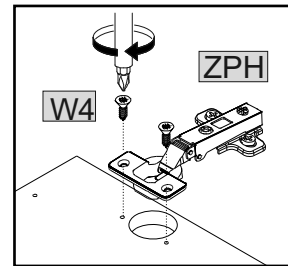
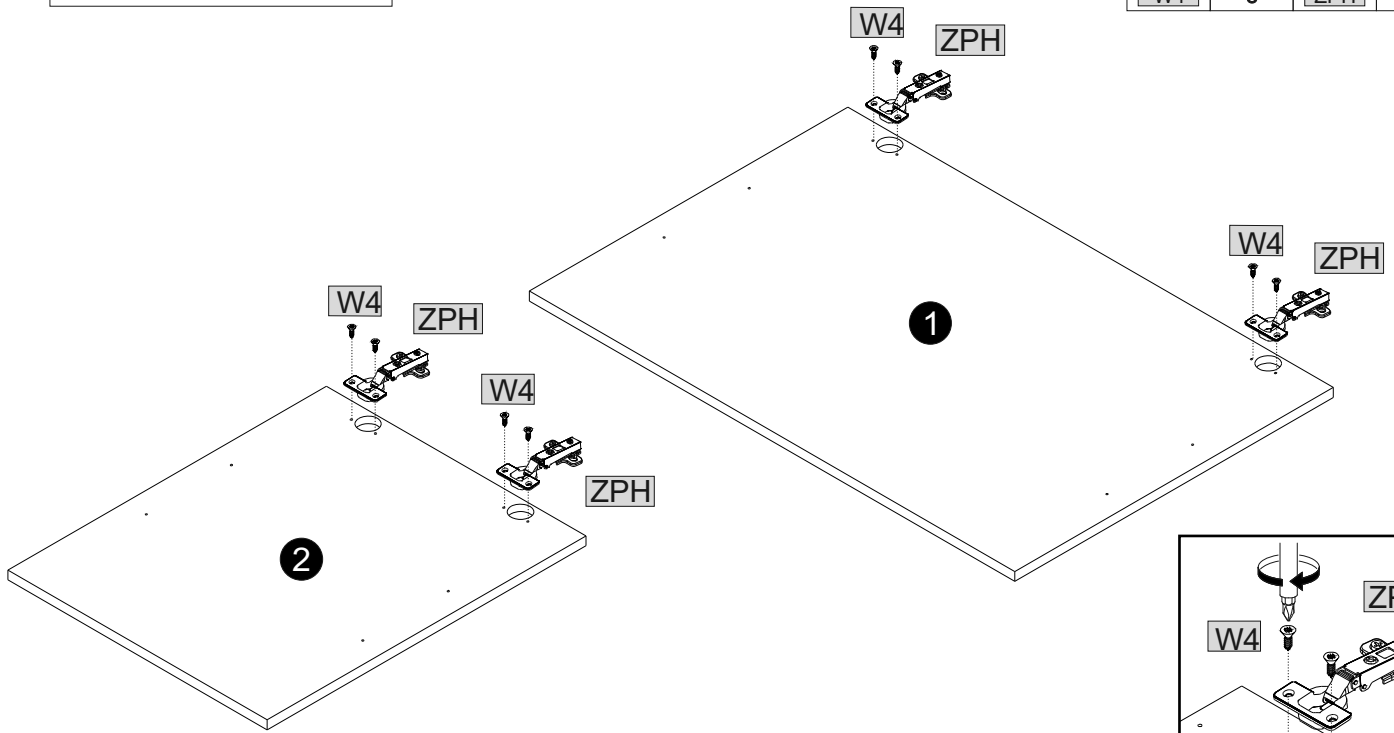

10

			3,5x25		
ZM1	8	WU	4	U18	2

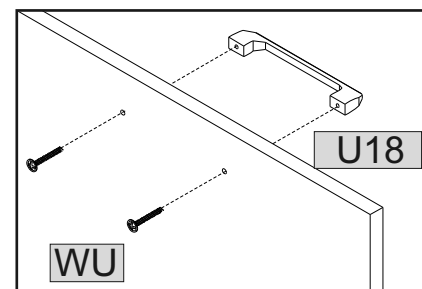
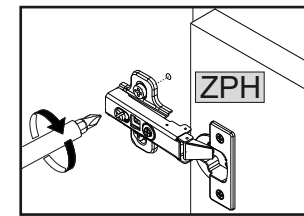
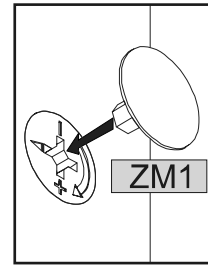
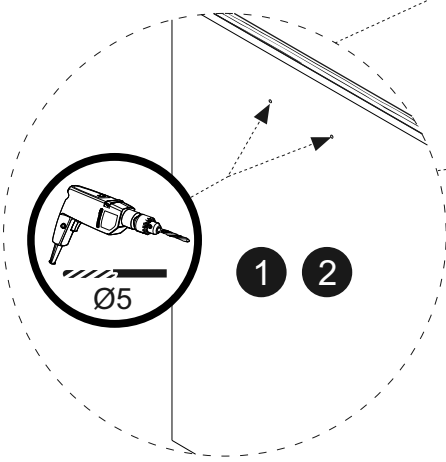
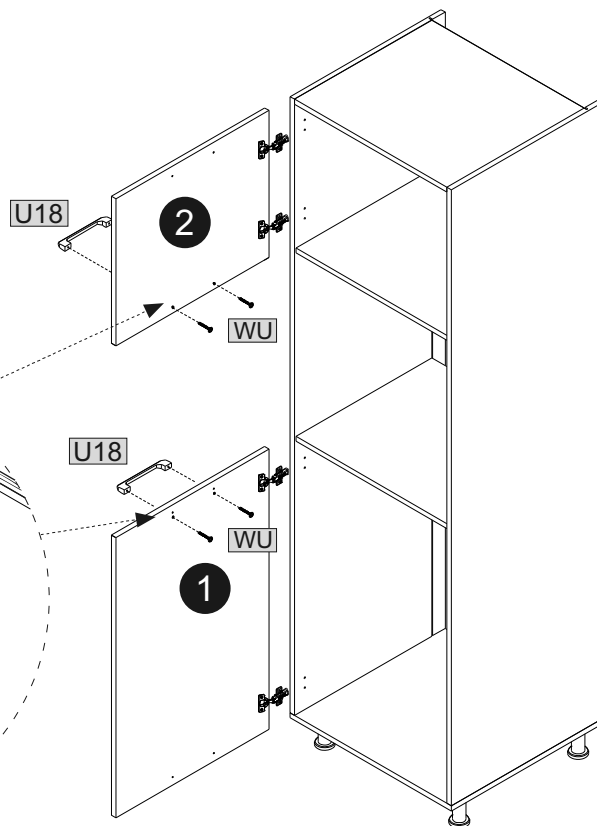
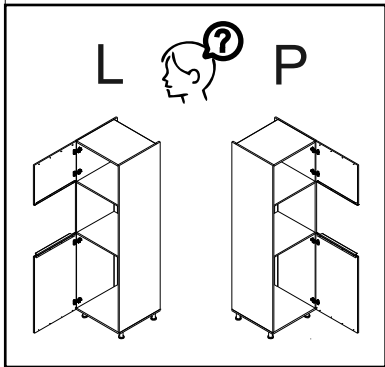

11

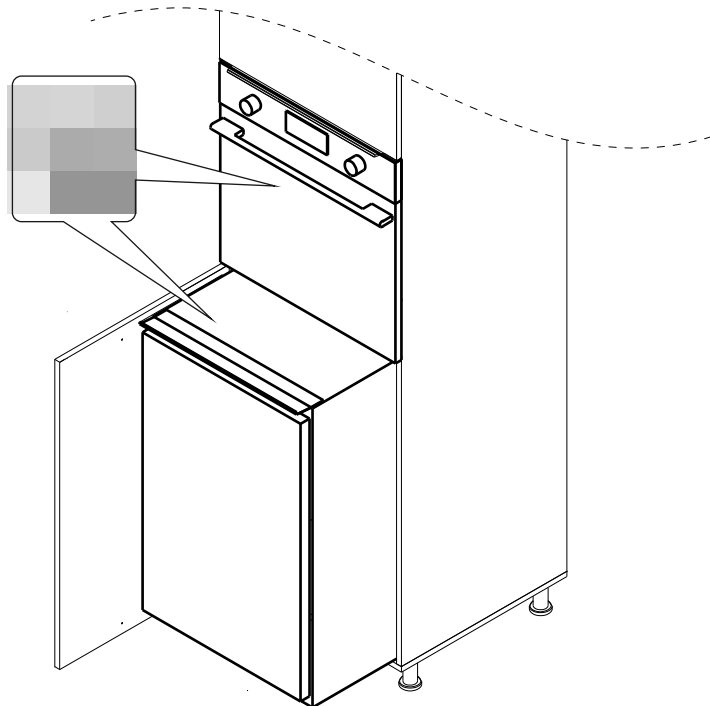

12

KO1	KN1	W11
1	6	12

3,5x16

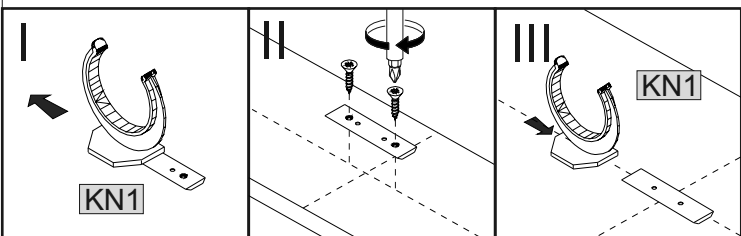
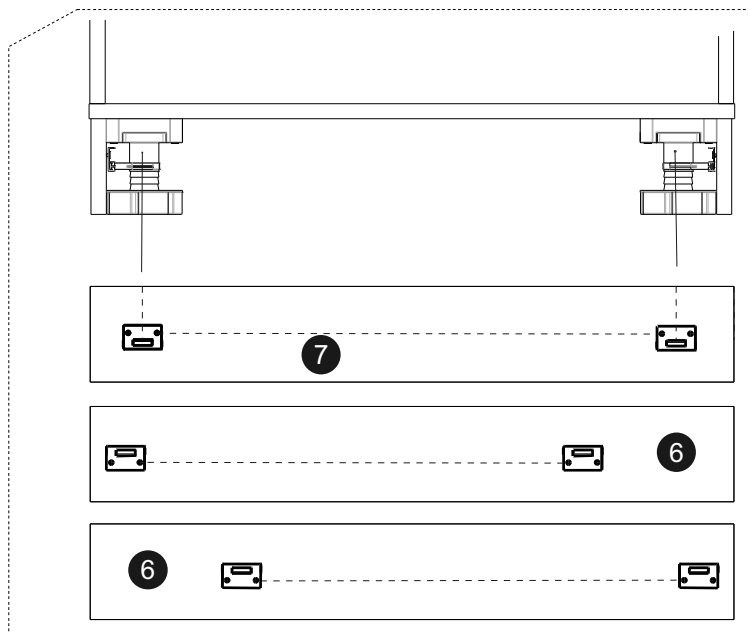
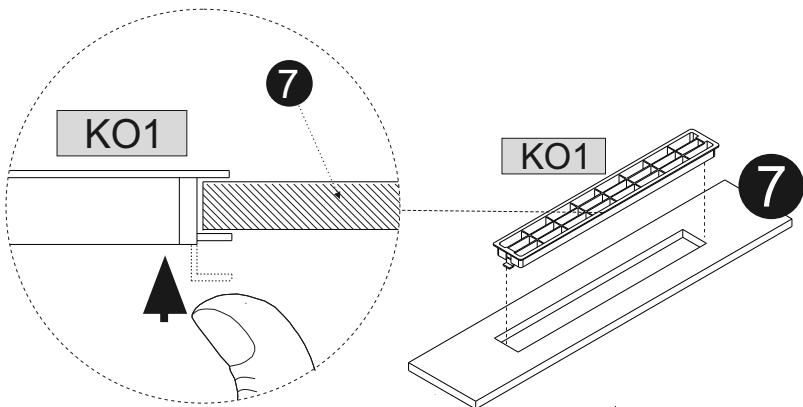
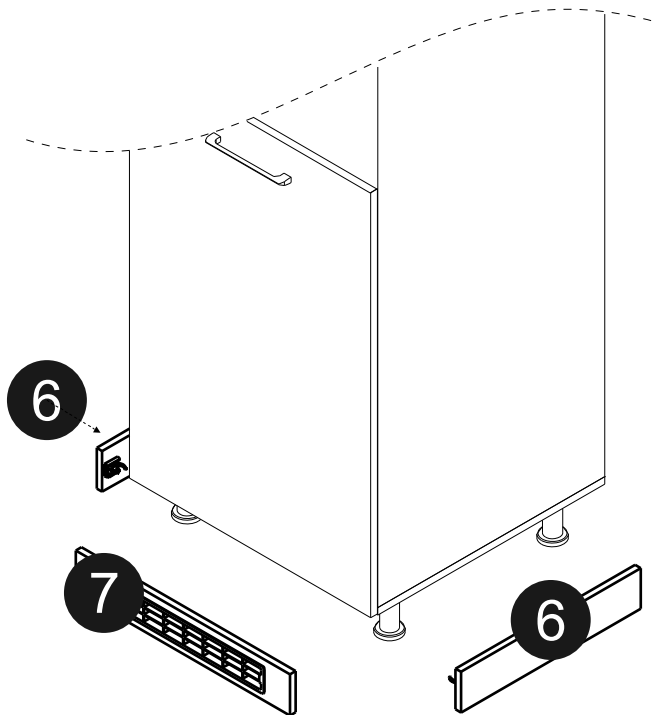

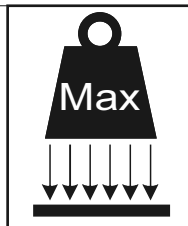
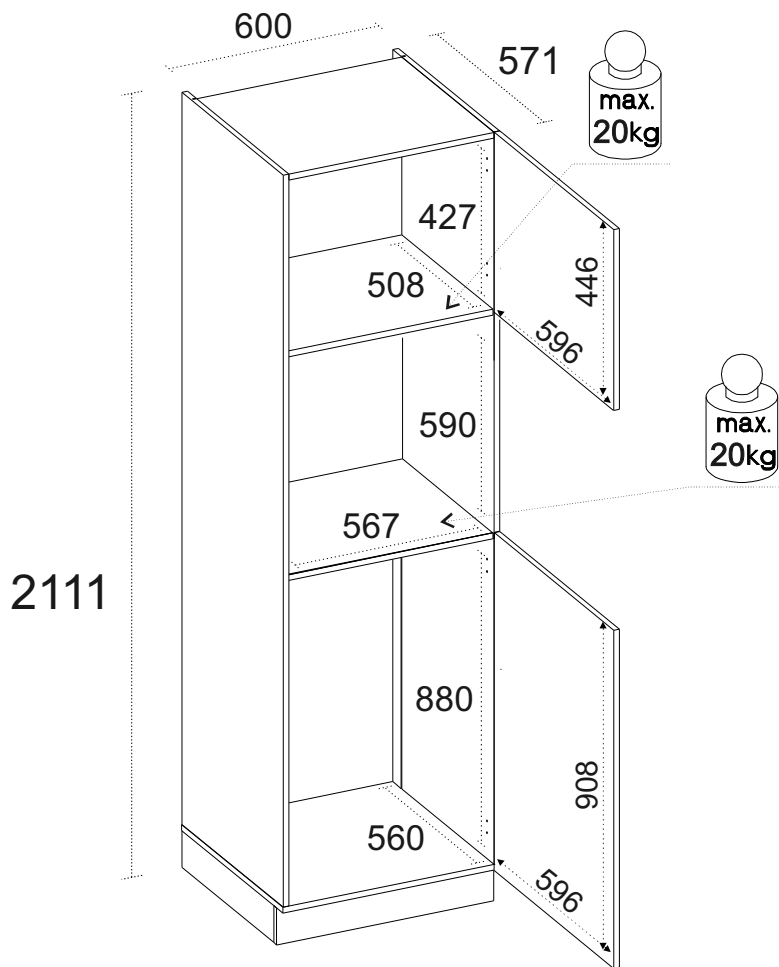
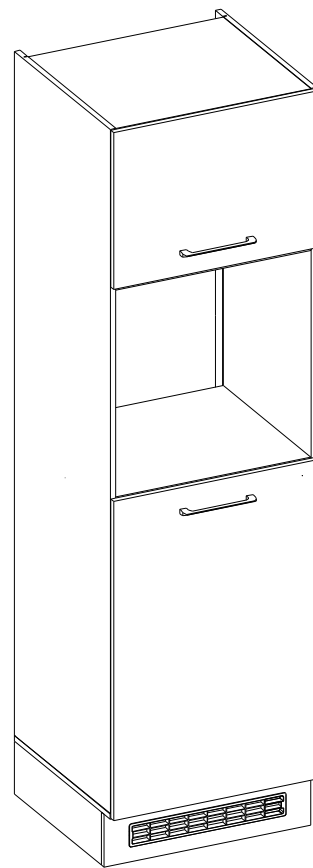
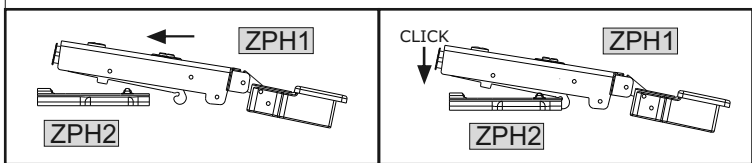
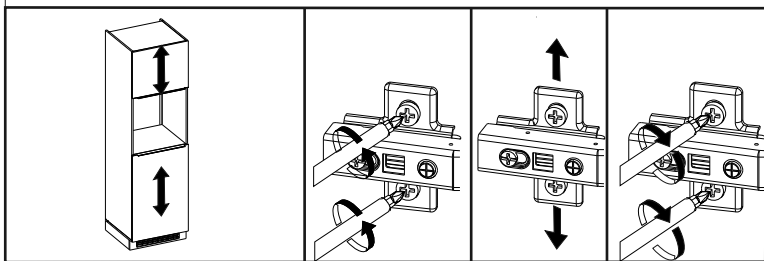
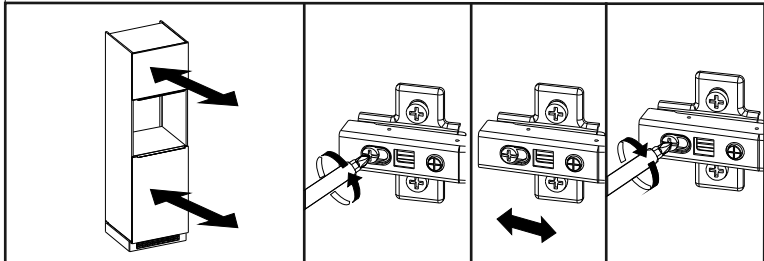
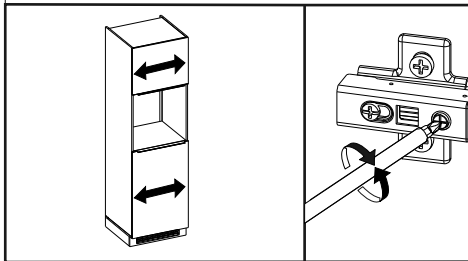

DE	<p>Warnhinweis: Wenn der Ware Dübel und Schrauben beiliegen, sind sie ausschließlich zur Anwendung an Wänden aus massiven und einheitlichen Materialien bestimmt, um ein Umkippen zu verhindern. Vergewissern Sie sich vor dem Bohren, dass sich keine Gas-, Wasser-, oder Stromleitungen an der Bohrstelle befinden. Zur Befestigung an anderen Wänden müssen Spezialdübel verwendet werden. Erkundigen Sie sich im Handel nach den für die jeweilige Wandbeschaffenheit geeigneten Schrauben und oder Dübel. Für eine unsachgemäße Montage und dadurch entstandene Schäden übernimmt der Hersteller keine Haftung. Bitte alle Schrauben in regelmäßigen Abständen überprüfen und nachziehen.</p>
FR	<p>Avertissement : Pour éviter le basculement accidentel du meuble, la fixation du meuble au mur est obligatoire. Si des chevilles et des vis sont fournies avec l'article, elles sont exclusivement destinées à être utilisées sur des murs en matériaux massifs et homogènes pour éviter tout basculement. Avant de percer, assurez-vous qu'aucune conduite de gaz, d'eau ou d'électricité ne se trouve à l'endroit où vous percez. Pour la fixation sur d'autres murs, il faut utiliser des chevilles spéciales. Renseignez-vous en magasin sur les vis et les chevilles adaptées à chaque type de mur. Le fabricant décline toute responsabilité en cas de montage incorrect et de dommages qui en résulteraient. Veuillez vérifier et resserrer toutes les vis à intervalles réguliers. ATTENTION ! Les meubles contenant des panneaux à base de bois (panneaux de particules, panneaux de fibres, contreplaqué...) peuvent émettre des substances polluantes dans l'air intérieur. Il est ainsi recommandé, après l'installation du meuble dans son logement, d'aérer fréquemment la pièce concernée pendant au moins quatre semaines afin de réduire son exposition aux polluants émis par le meuble LED: Ce luminaire est un produit de décoration. Ce luminaire ne convient pas pour l'éclairage principal d'une pièce de la maison.</p>
UK	<p>Warning: If dowels and screws are included with the product, they are only intended for use on walls made of solid and uniform materials to prevent them from tipping over. Before drilling, make sure that there are no gas, water or electricity pipes at the drilling site. Special anchors must be used for fastening to other walls. Ask in the trade for the screws and or dowels suitable for the respective wall condition. The manufacturer accepts no liability for improper installation and any resulting damage. Please check and retighten all screws at regular intervals.</p>
IT	<p>Avvertenza: Se con il prodotto sono forniti tasselli e viti, questi sono destinati esclusivamente all'utilizzo su pareti realizzate con materiali solidi ed uniformi, per evitare il ribaltamento. Prima di eseguire i fori assicurarsi che non ci siano condutture di gas, acqua o elettriche vicino al punto di perforazione. Per il fissaggio ad altre pareti è necessario utilizzare tasselli speciali. Chiedere al proprio rivenditore le viti e/o tasselli adatti al tipo di parete in questione. Il produttore non si assume alcuna responsabilità in caso di montaggio improprio e dei danni che ne derivano. Controllare e serrare tutte le viti a distanza regolare.</p>
PL	<p>Ostrzeżenie: Jeżeli do towaru dołączone są kołki i śruby, są one przeznaczone wyłącznie do stosowania na ścianach wykonanych z solidnych i jednolitych materiałów, aby zapobiec przewróceniu. Przed rozpoczęciem wiercenia należy upewnić się, że w miejscu wiercenia nie są ułożone rury gazowe, wodociągowe lub przewody elektryczne. Do mocowania do innych ścian należy stosować kołki specjalne. O śruby lub kołki odpowiednio dla konstrukcji danej ściany należy pytać w sklepach specjalistycznych. Producent nie ponosi odpowiedzialności za nieprawidłowy montaż i wynikłe z tego tytułu szkody. Wszystkie śruby należy regularnie sprawdzać i dokręcać.</p>
ESP	<p>Advertencia: En el caso de incluirse tacos y tornillos con la mercancía, estos están previstos únicamente para su uso en paredes macizas y homogéneas a fin de evitar un posible vuelco. Antes de taladrar, asegúrese de que por el punto de perforación no pasan tuberías de gas o agua o cables eléctricos. Para la fijación en otro tipo de paredes deben utilizarse tacos especiales. Pregunte en la tienda por los tornillos o tacos adecuados para las características de la pared en cuestión. El fabricante no asume ninguna responsabilidad por un montaje incorrecto ni por los daños resultantes del mismo. Compruebe todos los tornillos en intervalos regulares y apriételes.</p>
CZ	<p>Výstražné upozornění: Pokud jsou k výrobku přiloženy hmoždinky a šrouby, jsou určeny výhradně pro použití do stěn zhotovených z masivních a homogenních materiálů, a to za účelem zajištění proti převrácení. Před vrtáním se ujistěte, že se v místě vrtání nenachází vedení plynu, vody nebo elektřiny. Pro připevnění k jiným stěnám je nutné použít speciální hmoždinky. Informujte se v obchodě o hmoždinkách a/nebo šroubech vhodných pro příslušnou strukturu stěny. Výrobce nenese odpovědnost za nesprávnou montáž a za škody jí způsobené. Všechny šrouby pravidelně kontrolujte a dotahujte.</p>
SK	<p>Informácia o nebezpečenstve: Ak sú k tovaru priložené príchytky a skrutky, sú určené výlučne na použitie na stenách z masívnych a jednotných materiálov, aby sa zabránilo prevráteniu. Pred vrtaním sa uistite, že sa na vrtanom mieste nenachádzajú žiadne plynové, vodovodné alebo elektrické vedenia. Na upevnenie na iných stenách musia byť použité špeciálne príchytky. Spýtajte sa v predajni na skrutky a/alebo príchytky vhodné pre príslušný typ steny. Výrobca nepreberá ručenie za nesprávnu montáž a tým vzniknuté škody. Všetky skrutky v pravidelných intervaloch kontrolujte a dotiahnite.</p>
HU	<p>Figyelmeztetés: Amennyiben a termék csomagolásá tipliket és csavarokat is tartalmaz, azok kizárólag masszív, egységes anyagból készült falakon használhatók, a felborulás megakadályozásának céljából. A fúrás előtt bizonyosodjon meg arról, hogy a fúrás helyén nem található gáz-, víz- vagy elektromos vezetékek. Egyéb falakra történő rögzítéshez speciális tiplik szükségesek. Az egyes faltípusokkal használható megfelelő csavarokkal és/vagy tiplikkel kapcsolatos információkért kérjük, forduljon forgalmazójához. A nem szakszerű szerelésért és az abból keletkező károkért a gyártót semmilyen felelősség nem terheli. Minden csavart ellenőrizzen és rögzítsen rendszeresen.</p>
BG	<p>Предупредително указание: Ако в окомплектовката на доставката на стоката са включени дюбели и винтове, те са предназначени единствено за употреба върху стени от масивни и еднородни материали, за да се предотврати преобръщане. Преди пробиване се уверете, че на мястото на пробиване няма тръби за газ, за вода или електрически проводници. За закрепване към други стени трябва да се използват специални дюбели. Информирайте се в търговската мрежа относно подходящите винтове и/или дюбели за съответната конструкция на стената. Производителят не поема отговорност за неправилен монтаж и възникнали в резултат на това щети. Моля, проверявайте и затягвайте всички винтове на редовни интервали.</p>
TR	<p>Uyarı: Ürün paketinde dübel ve vida varsa, bunlar devrilmeyi önlemek amacıyla, sadece masif ve yekpare malzemelerden imal edilmiş duvarlardaki kullanımları için öngörülmüştür. Matkapla delik açmadan önce delme noktasında gaz, su veya elektrik hatlarının olmadığından emin olun. Ürünü başka duvarlara sabitlemek için özel dübeller kullanılmalıdır. Piyasadaki satıcılardan ilgili duvarın özelliğine uygun vidalar ve dübeller hakkında bilgi alın. Usulüne aykırı bir montaj ve bu nedenle oluşmuş hasarlar için üretici sorumluluk almamaktadır. Lütfen tüm vidaları düzenli aralıklarla kontrol edip tekrar sıkın.</p>

PT	Advertência: Caso o produto venha com buchas e parafusos incluídos, os mesmos são exclusivamente destinados à fixação em paredes de materiais sólidos e uniformes, para evitar que o produto tombe. Antes de iniciar a perfuração, certifique-se de que não existem canalizações de gás, água ou fios elétricos a passar no local dos furos. Para a fixação nouro tipo de paredes, têm de ser utilizadas buchas especiais. Informe-se junto de um comerciante especializado sobre os parafusos e buchas a utilizar na parede específica. O fabricante não assume qualquer responsabilidade no caso de uma montagem inadequada e qualquer dano daí resultante. Verifique e volte a apertar todos os parafusos regularmente.
SI	Opozorilo: če so blagu priloženi zidni vložki in vijaki, so ti namenjeni izključno za uporabo na stenah iz masivnih in enotnih materialov, da se prepreči prevrtitev. Pred vrtnanjem se prepričajte, da na mestu vrtnanja ni plinskih, vodnih ali električnih napeljav. Za pritrditev na druge stene je treba uporabljati posebne zidne vložke. Pozanimajte se v trgovini o vijakih in/ali zidnih vložkih, primernih za posamezno sestavo stene. Proizvajalec ne prevzema jamstva za nepravilno montažo in zaradi tega nastalo škodo. Vse vijake redno preverjajte in naknadno privijajte.
NL	Waarschuwing: Indien er bij het product pluggen en schroeven zijn meegeleverd, zijn deze uitsluitend bestemd om in muren van massieve en homogene materialen te gebruiken om te voorkomen dat het product kantelt. Controleer voordat u begint of er geen gas-, water- of elektriciteitsleidingen lopen waar u gaat boren. Voor de bevestiging aan andere soorten muren moeten speciale pluggen worden gebruikt. Informeer in de winkel welke schroeven en/of pluggen geschikt zijn voor de desbetreffende muur. De fabrikant is niet aansprakelijk voor een onjuiste montage en de daardoor ontstane schade. Controleer regelmatig of alle schroeven nog goed vastzitten en draai ze zo nodig vast.
SRB	Upozoravajuća napomena: Ako su uz robu priloženi tiplovi i zavrtaji, isti su namenjeni isključivo za primenu na zidovima od kompaktnih i homogenih materijala, kako bi se sprečilo prevrtanje. Pre bušenja se uverite da se na mestu bušenja ne nalaze vodovi za gas, vodu ili struju. Za fiksiranje na drugačijim zidovima moraju da se upotrebe specijalni tiplovi. Raspitajte se u trgovini o zavrtajima i/ili tiplovima koji su adekvatni za dotičnu teksturu zida. Proizvođač ne preuzima nikakvu odgovornost za nestručnu montažu i štete koje su nastale na taj način. Sve zavrtnje kontrolišite i dotežite u redovnim intervalima.
RO	Indicație de avertizare: Dacă produsul este livrat împreună cu șuruburi și dibluri, acestea sunt destinate exclusiv utilizării pe pereții construiți din materiale masive și uniforme, pentru a preveni răsturnarea produsului. Înainte de a realiza găurile, asigurați-vă că nu există conducte de gaz, apă sau electricitate în locul pe care doriți să-l găuriți. Pentru prinderea pe alte tipuri de pereți, trebuie să utilizați dibluri speciale. Interesați-vă la magazinul specializat, pentru a găsi șuruburile și/sau diblurile potrivite pentru peretele dvs. Producătorul nu este responsabil, în cazul unui montaj necorespunzător pentru daunele rezultate. Vă rugăm să verificați toate șuruburile la intervale regulate și să le strângeți.
HR	Upozorenje: Ako su uz proizvod priložene tiple i vijci, oni su namijenjeni isključivo za korištenje na zidovima od čvrstih i jednoličnih materijala kako bi se spriječilo prevrtanje. Prije bušenja provjerite da na mjestu bušenja nema električnih vodova, plinskih ili vodovodnih cijevi. Za pričvršćivanje na ostale zidove potrebno je koristiti posebne tiple. Prilikom kupnje raspitajte se kod svog prodavača o vijcima i tiplama koji su prikladni za odgovarajuću zidnu strukturu. Proizvođač ne odgovara za štete nastale uslijed nepravilne montaže. Sve vijke potrebno je redovito provjeravati i zategnuti.
SE	Varning: Om plugg och skruvar följer med produkten är de endast avsedda för väggar av massivt och enhetligt material för att förhindra att produkten vippar. Försäkra dig om att inga gas-, vatten- eller elledningar befinner sig på platsen som du ska borra innan du börjar. För fastsättning i väggen måste specialplugg användas. Informera dig i en butik om vilka skruvar och plugg som passar till vilken vägg. För en felaktig montering och skador som uppstår på grund av detta tar tillverkaren inget ansvar. Kontrollera och dra åt alla skruvar med jämna mellanrum.
RUS	Предупреждение: Если изделие поставляется вместе с дюбелями и шурупам, они предназначены исключительно для использования на стенах из монолитных и однородных материалов, чтобы предотвратить возможное обрушение. Перед началом сверления убедитесь, что на месте сверления нет газопровода, водопровода или электропроводки. Для крепления к другим стенам необходимо использовать специальные дюбели. Узнайте у продавца, какие шурупы или дюбели подходят для соответствующей структуры стены. Производитель не несет ответственности за неправильный монтаж и вызванный им ущерб. Регулярно проверяйте и подтягивайте все шурупы.
UKR	Попередження: Якщо до виробу додаються дюбелі та гвинти, вони призначені виключно для використання на стінах з цільних й однорідних матеріалів, щоб не допустити перекидання. Перед свердлінням переконайтеся, що на місці свердління немає ліній газо-, водопостачання чи електропроводки. Для кріплення до інших стін необхідно використовувати спеціальні дюбелі. Запитайте продавця, які гвинти та/або дюбелі підходять для стіни з відповідною структурою. Виробник не несе відповідальності за неправильний монтаж та збитки, що виникли внаслідок цього. Перевіряйте та підтягуйте всі гвинти через регулярні проміжки часу.
LT	Įspėjimas: jei prie prekės pridėtos mūrvinės ir varžtai, jie skirti naudoti tik ant sienų, pagamintų iš tvirtų ir vienuodų medžiagų, kad būtų galima išvengti apvirtimo. Prieš gręždami įsitinkite, kad gręžiamoje vietoje nėra dujotiekio, vandentiekio ar elektros linijų. Tvirtinant prie kito tipo sienų reikia naudoti specialias mūrvines. Teiraukitės pardavėjo atitinkamai sienos konstrukcijai tinkamų varžtų ir (arba) mūrvinių. Gamintojas neprisiima atsakomybės dėl netinkamo montavimo ir dėl to atsiradusios žalos. Visus varžtus reguliariai tikrinkite ir priveržkite.
LV	Brīdinājums: Ja precei ir pievienoti dībeļi un skrūves, prece ir paredzēta izmantošanai tikai uz sienām, kas izgatavotas no cietiem un viendabīgiem materiāliem, lai novērstu apgāšanos. Pirms urbšanas pārlicinieties, ka urbšanas vietā nav gāzes, ūdens vai elektropārvades līniju. Lai piestiprinātu pie citām sienām, jāizmanto speciāli dībeļi. Jautājiet savam izplatītājam par skrūvēm un/vai dībeļiem, kas ir piemēroti attiecīgajai sienas konstrukcijai. Ražotājs neuzņemas atbildību par nepareizu montāžu un no tās sekojošajiem bojājumiem. Lūdzu, regulāri pārbaudiet un pievelciet visas skrūves.
EE	Hoiatus! Kui tootele on kaasa pandud tüüblid ja kruvid, on need mõeldud kasutamiseks üksnes massiivsest ja ühtsest materjalist seintel, vältimaks ümberkukkumist. Veenduge enne puurimist, et puurimiskohas ei oleks gaasi- või veetorusid ega elektrijuhtmeid. Seintele kinnitamiseks tuleb kasutada spetsiaalseid tüüpleid. Uurige kaubandusvõrgust, millised kruvid ja/või tüüblid konkreetse seina jaoks sobivad. Tootja ei võta endale mittenõuetekohasest paigaldamisest tingitud kahjude eest mingit vastutust. Kontrollige ja järelpingutage kõiki kruvisid regulaarselt.



LE TRI
+ FACILE



FR

Donnez ou recyclez
vos meubles.



Association



Magasin



Déchèterie

<https://quefairedemesdechets.fr>

TURIN KS 60

73/007/..



„MEBLE-OKMED” DEMKO - SPÓŁKA JAWNA
ul. Kolejowa 13, 14-500 Braniewo, POLSKA
(+48) 55 243 27 26

ZP: .../...

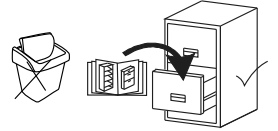

TURIN
KS 60
ZP:/..

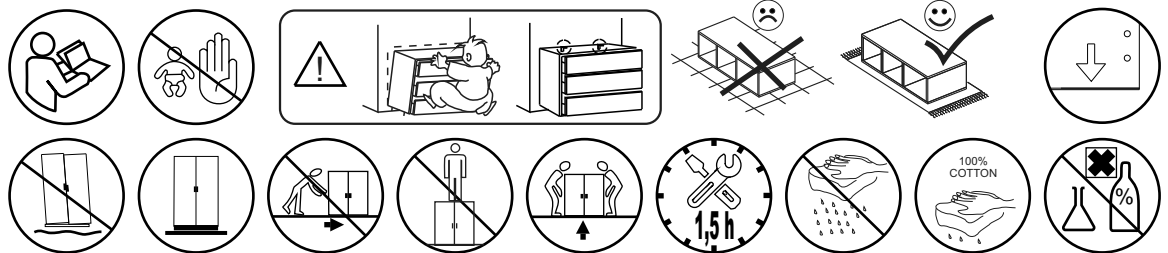
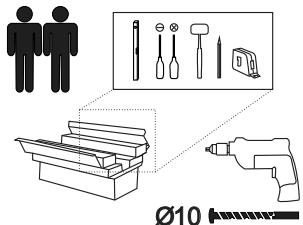
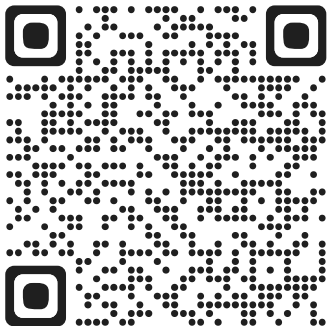
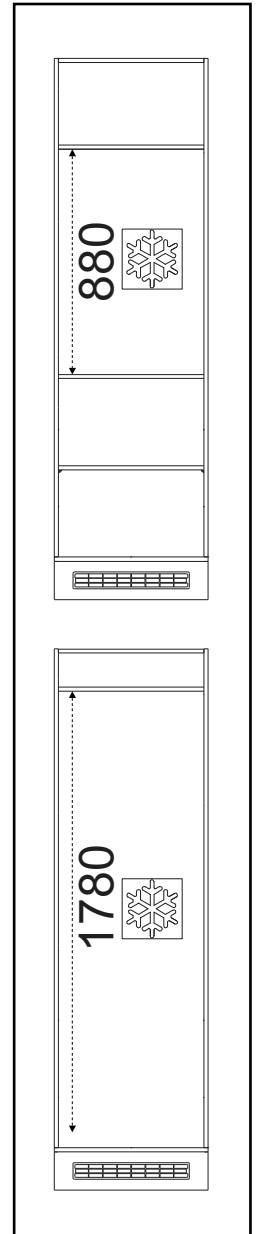
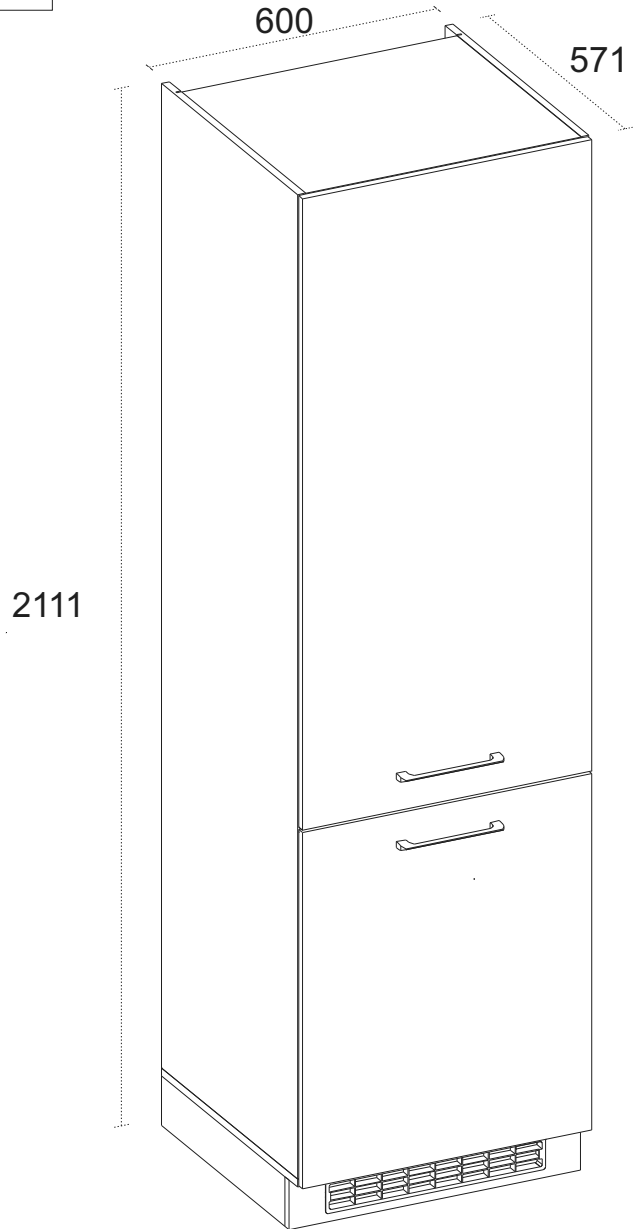

N	L [mm]	W [mm]	T [mm]	Q	COLLI
1	713	596	16	1	COLLI_1/2
2	1238	596	16	1	COLLI_1/2
3	715	583	3	1	COLLI_1/2
4	583	354	3	1	COLLI_1/2
5	583	160	3	1	COLLI_1/2
8	504	150	16	2	COLLI_1/2
9	600	150	16	1	COLLI_1/2
10	600	555	16	1	COLLI_1/2
11	567	500	16	1	COLLI_1/2
6	1945	555	16	1	COLLI_2/2
7	1945	555	16	1	COLLI_2/2
12	567	510	16	1	COLLI_2/2
13	567	508	16	2	COLLI_2/2

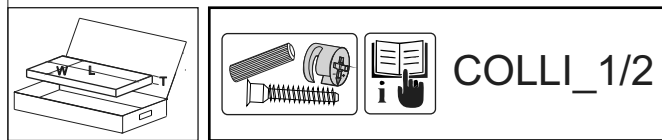

W5 16	PP 4	PMO2 4	
U18 2	KO1 1	KS1 2	
W4 10	W1 15	ZM1B 12	
ZM1A 12	KRW1 2	KRL1 2	
ZM1 8	ZPH 5	K3 4	
S1 8	NK1 4	KN1 6	
KT1 16	W11 32	KK1 1	WU 4

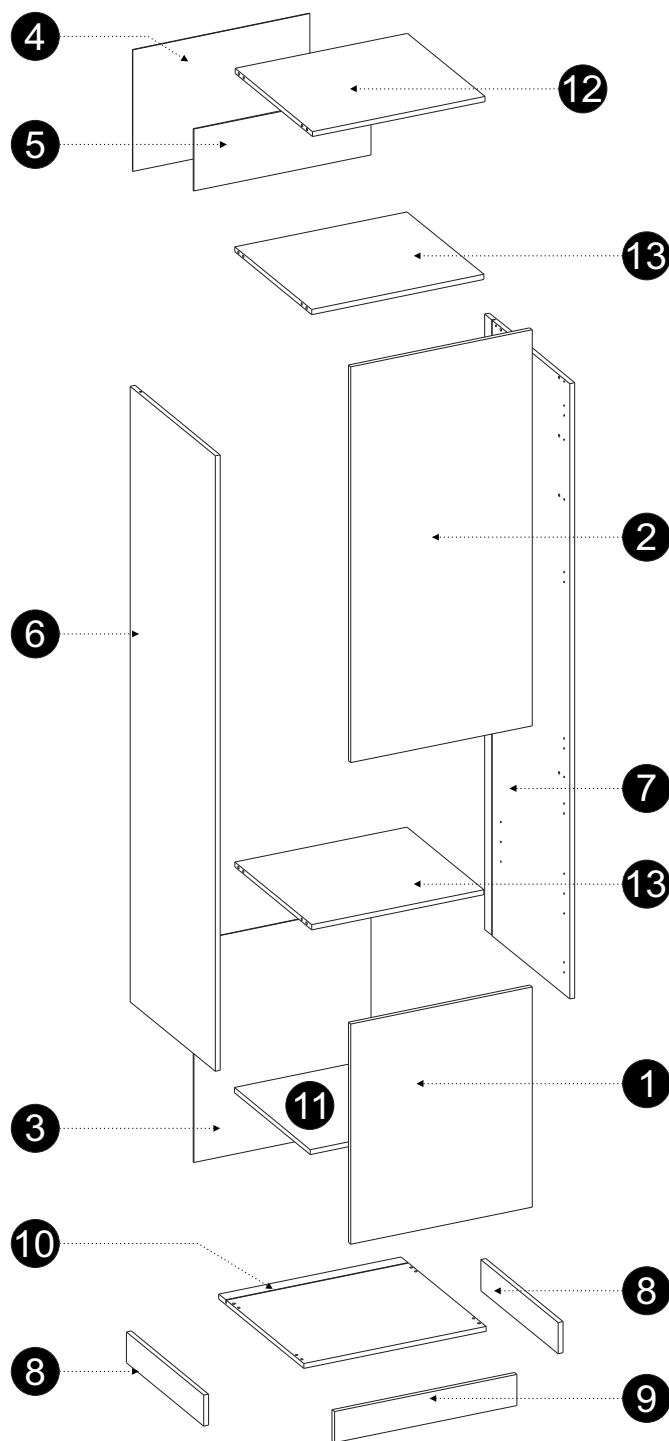



11-21

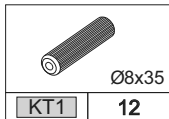
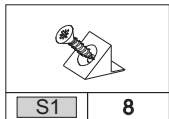
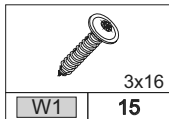
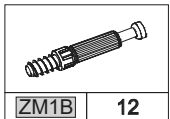
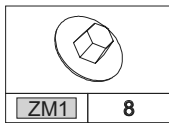
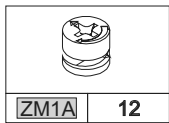
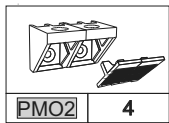
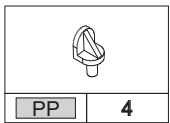
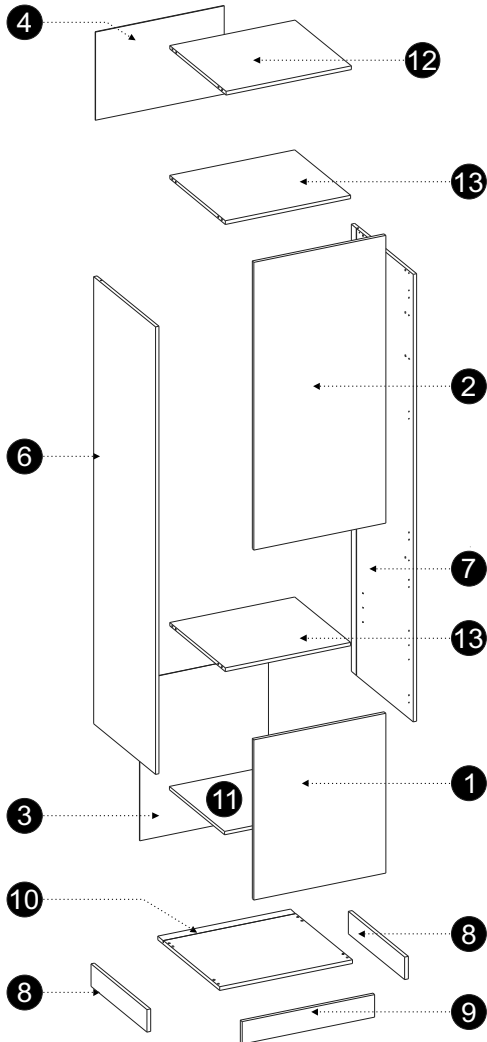
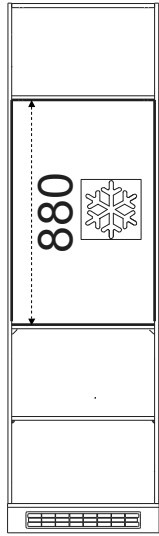

4-10 18-21

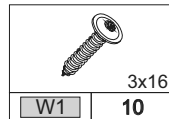
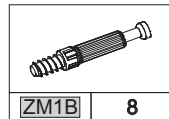
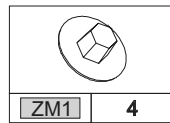
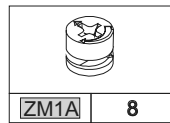
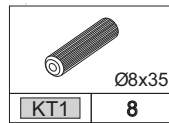
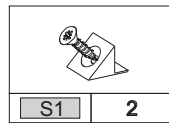
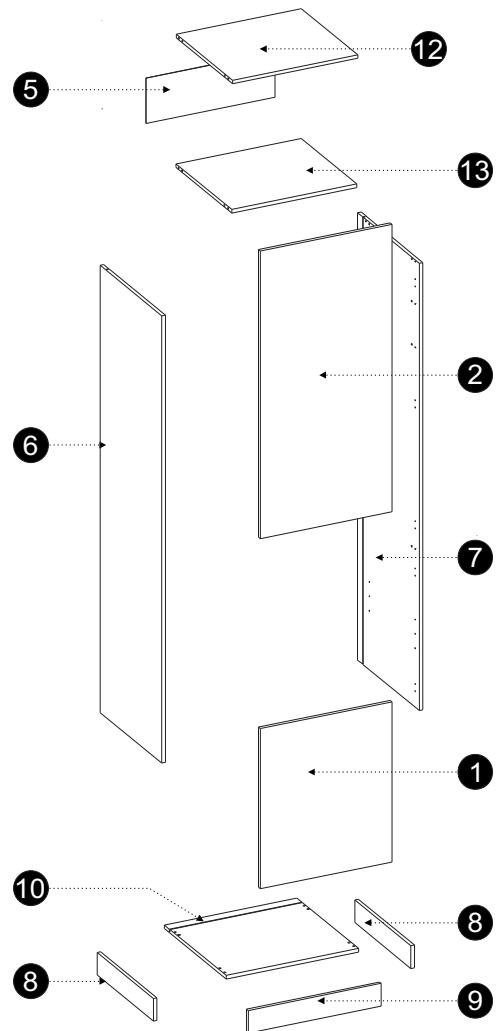
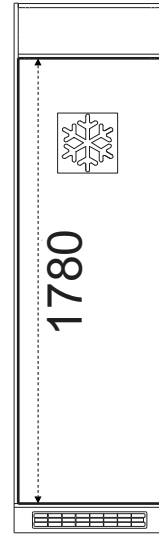

01

ZM1B	8	KT1	12
			$\text{Ø}8 \times 35$
		ZM1A	8

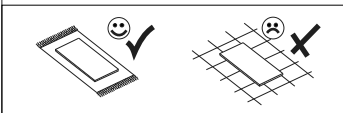
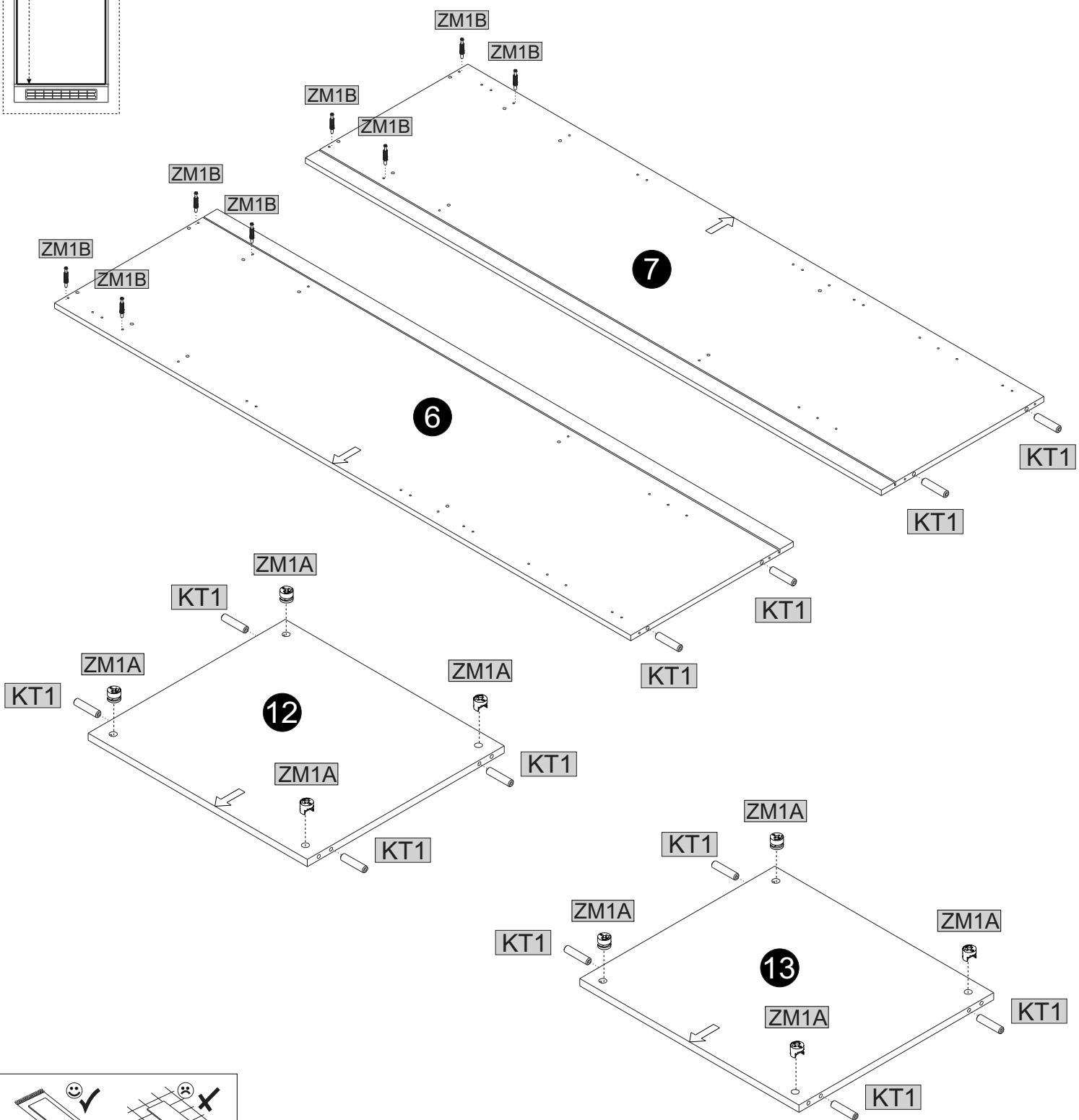
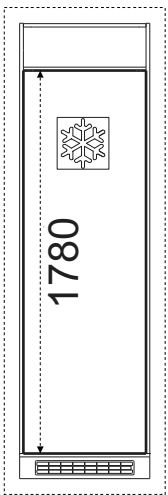
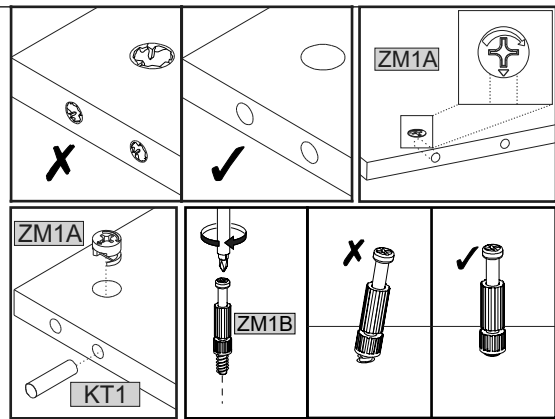

02

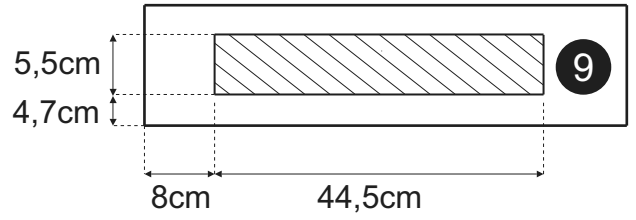
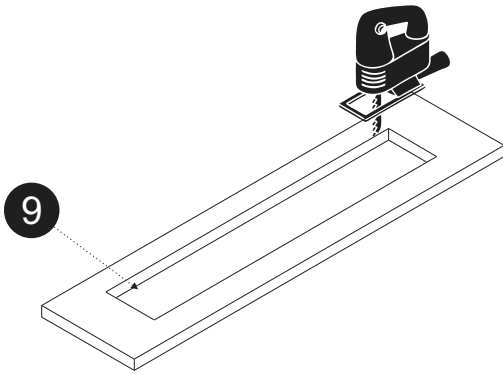
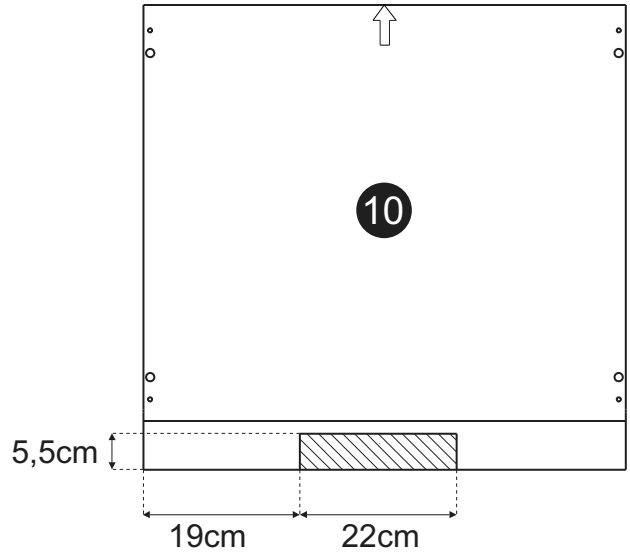
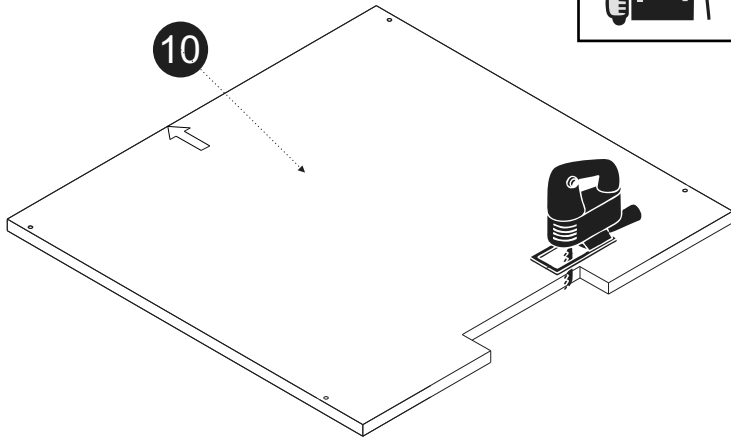

03

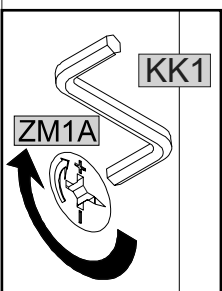
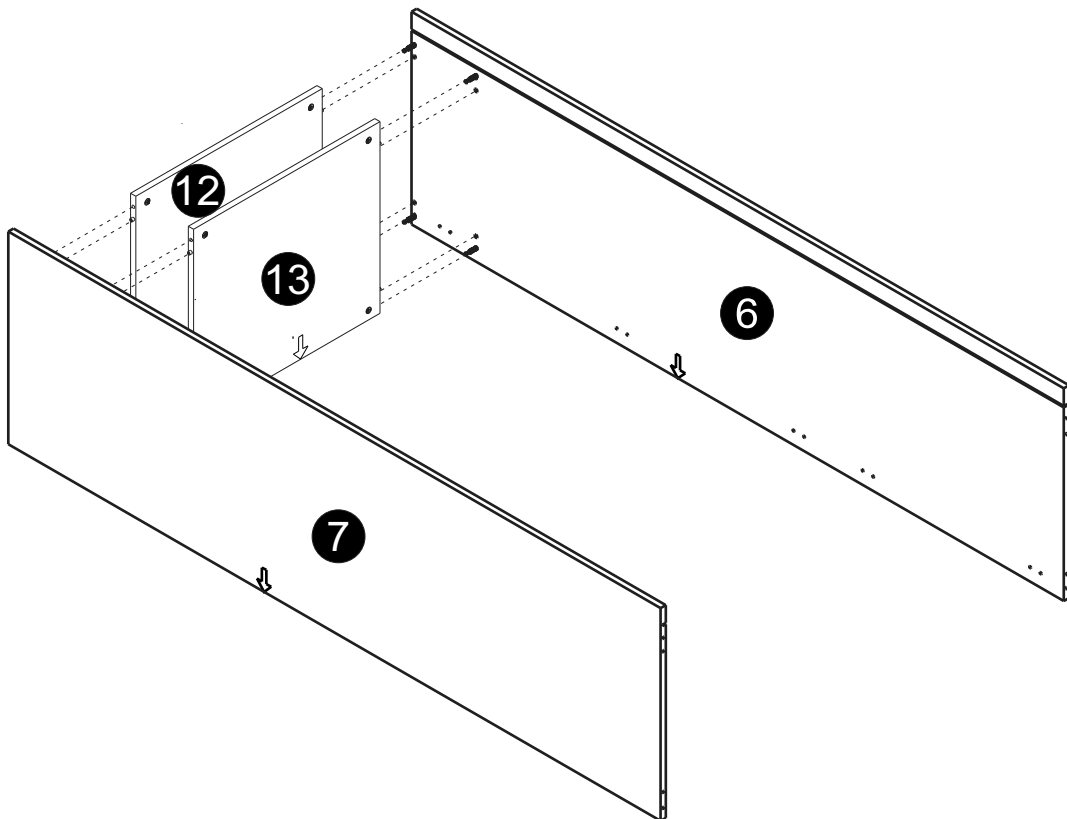
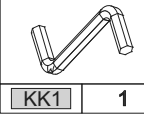
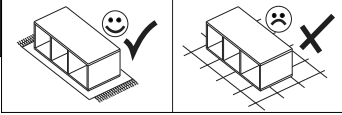

04

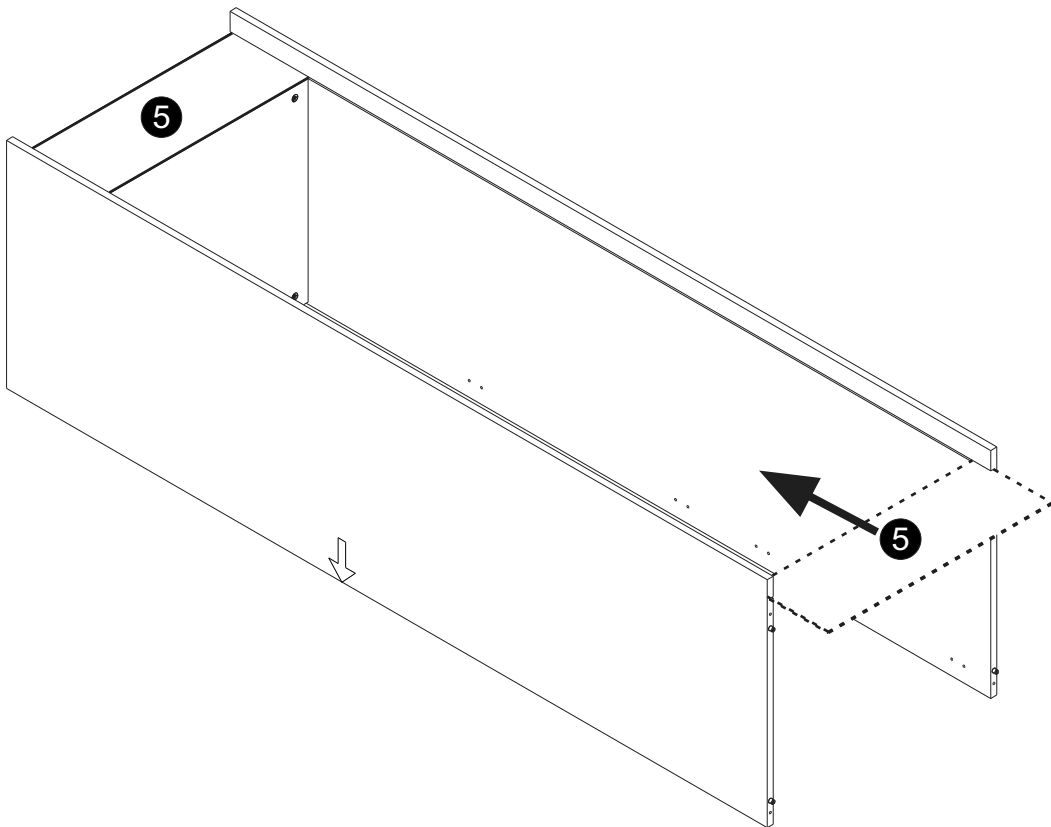
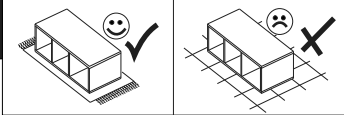

05

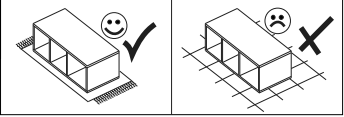

KK1	1	K3	4

6,4x50

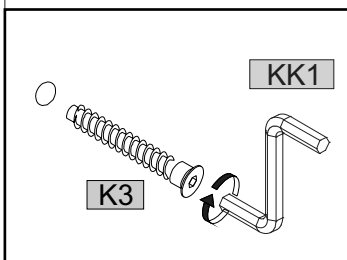
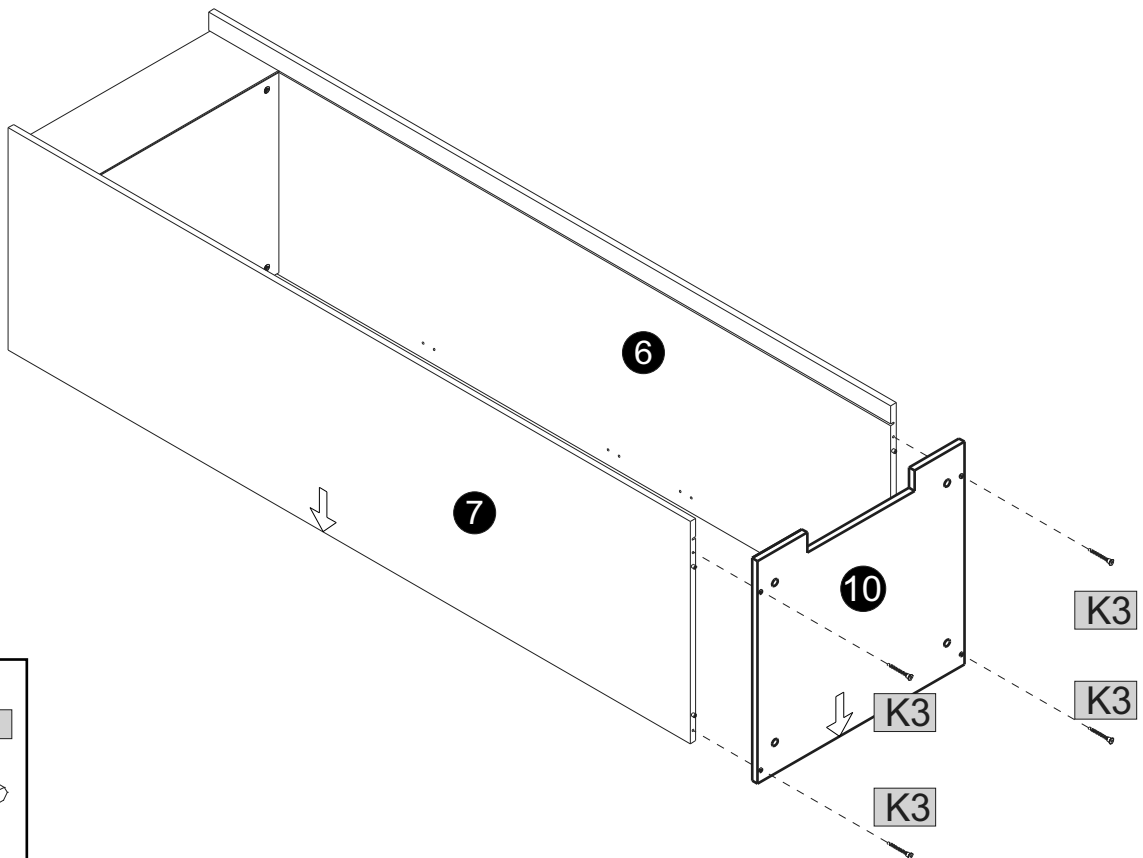

06

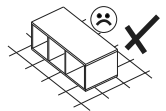
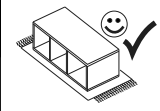

			3x16
S1	2	W1	10

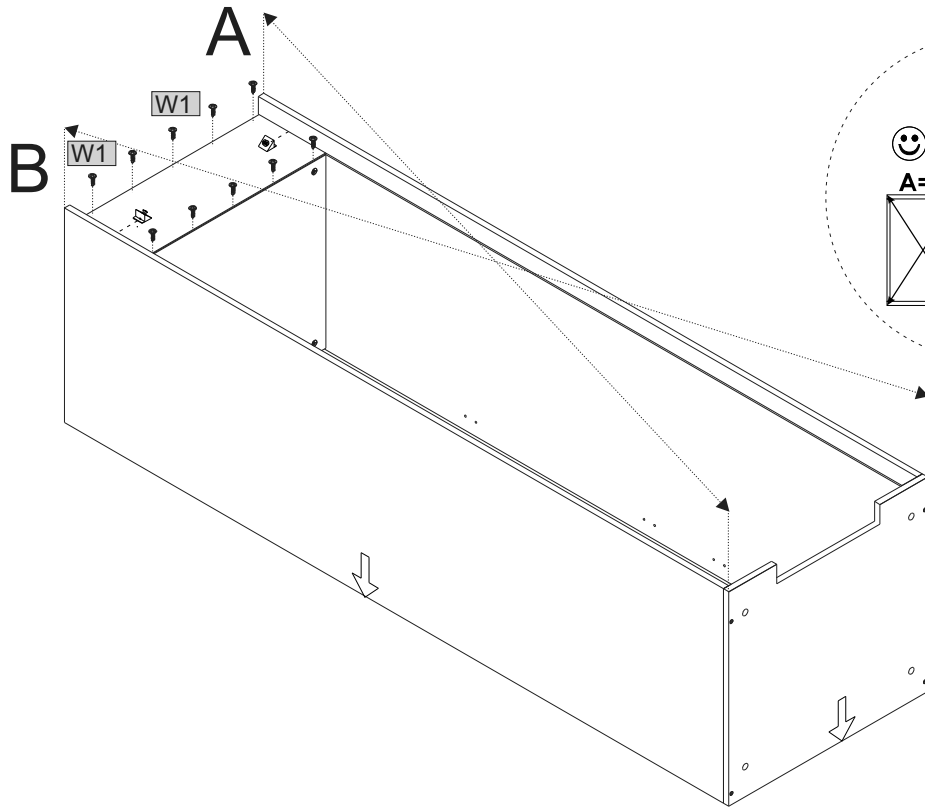
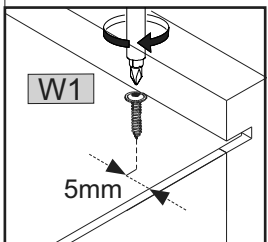
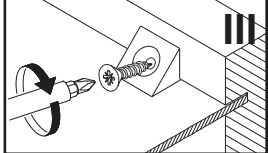
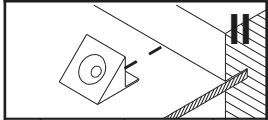
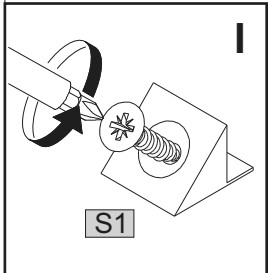



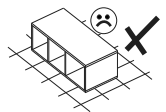
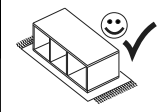

07

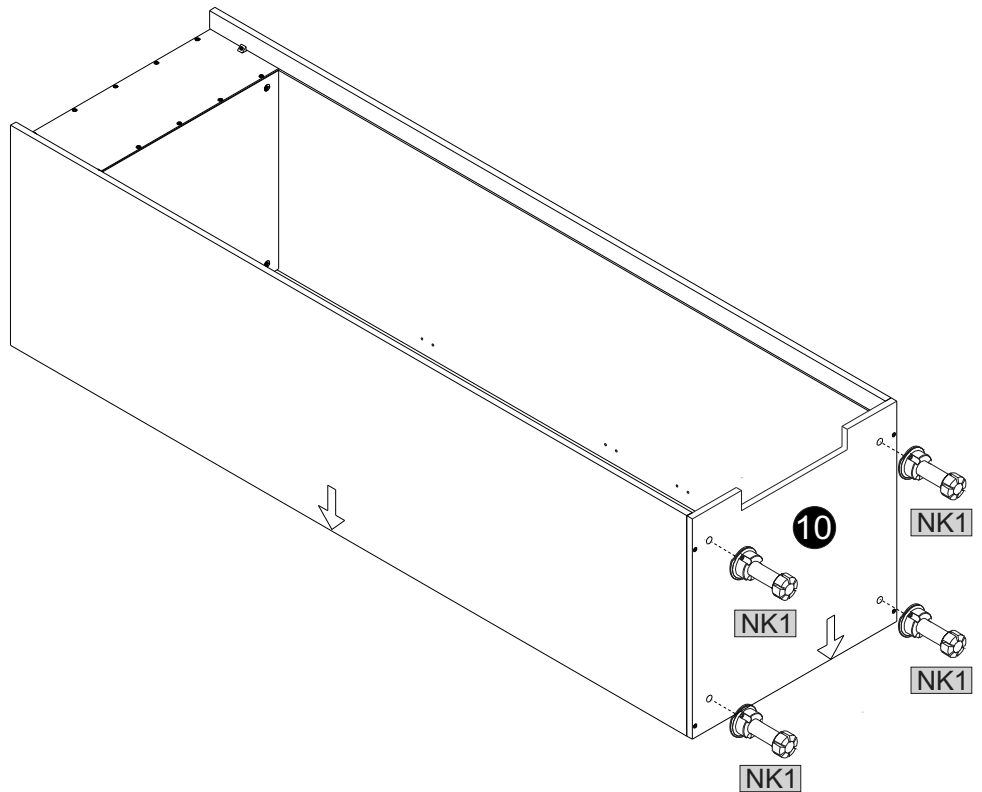
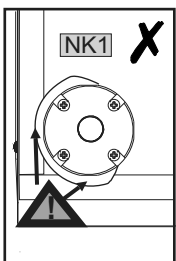
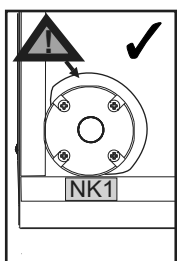
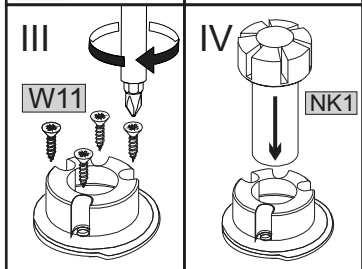
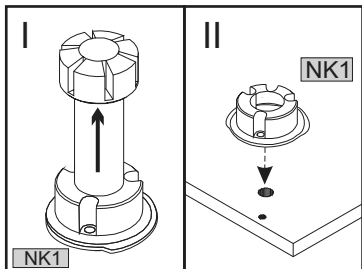

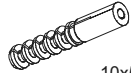
	3,5x16		
W11	16	NK1	4



	10x50		6x50		3,5x16		
KRW1	2	KRL1	2	W11	4	KS1	2

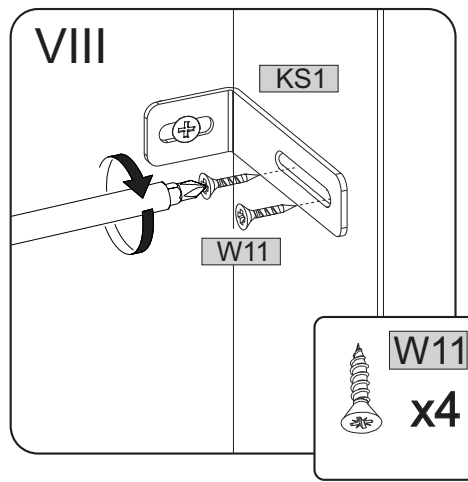
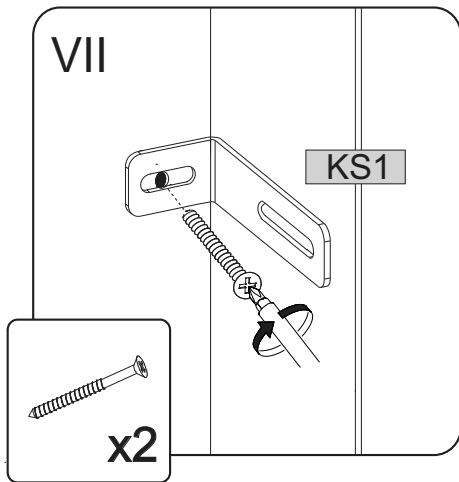
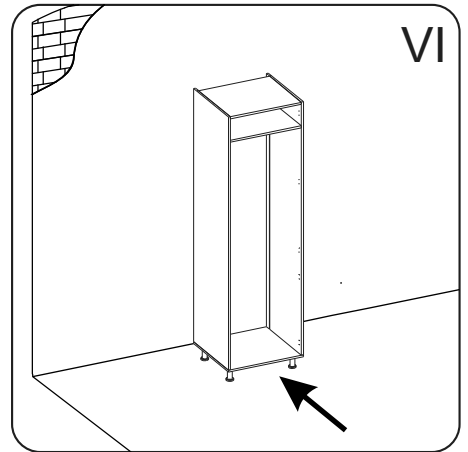
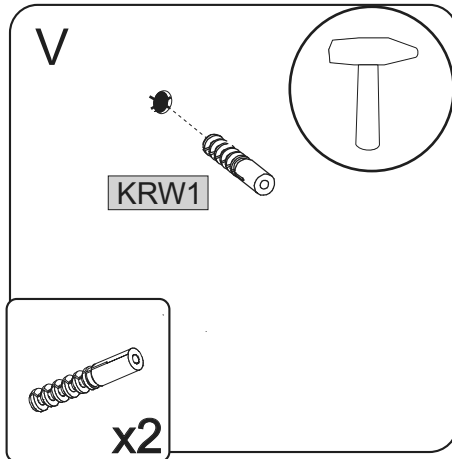
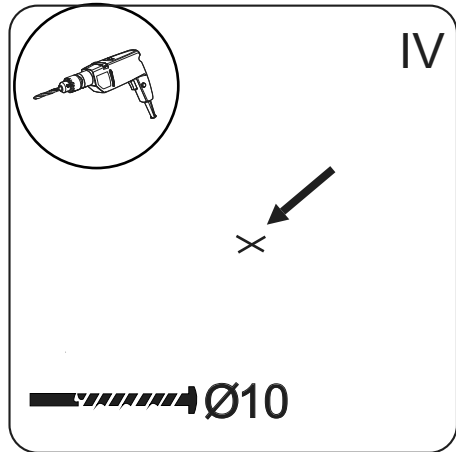
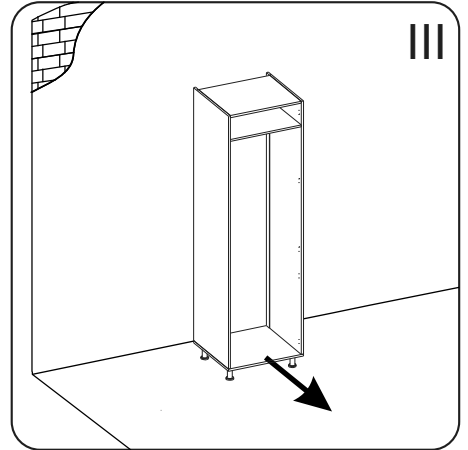
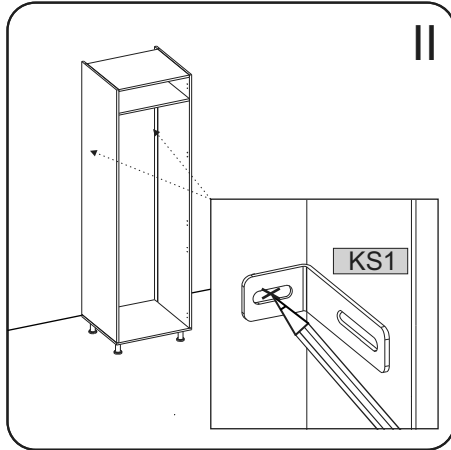
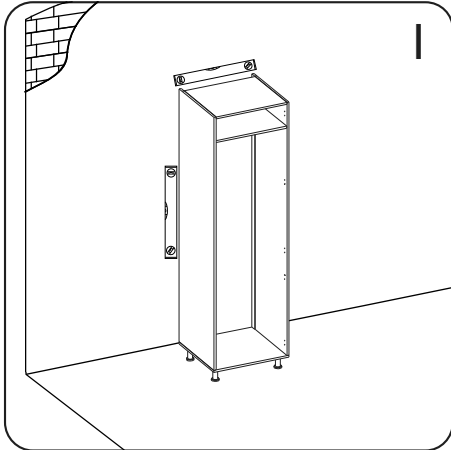
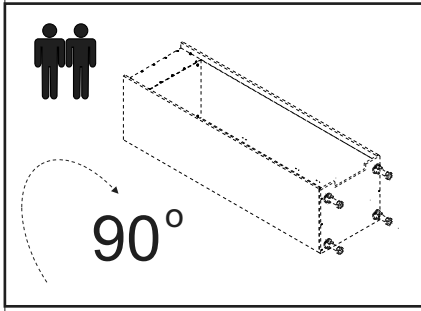

09

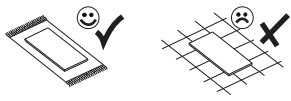

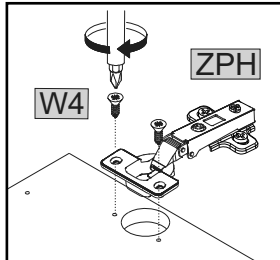
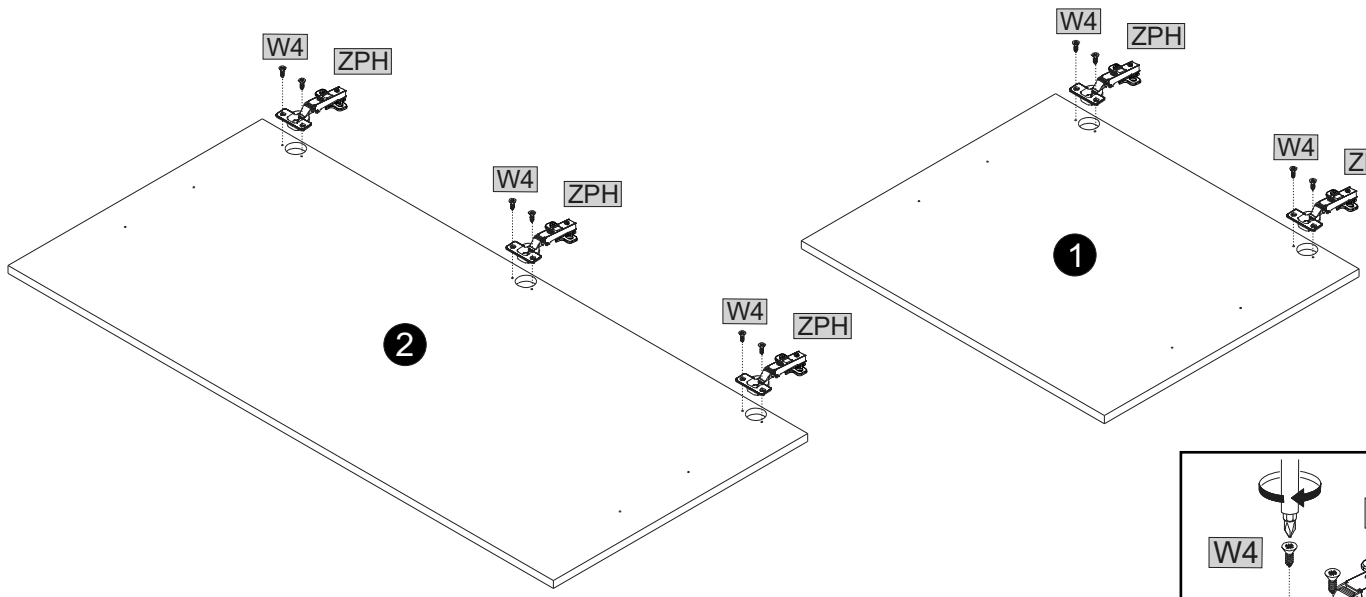

		4x13	
W4	10	ZPH	5

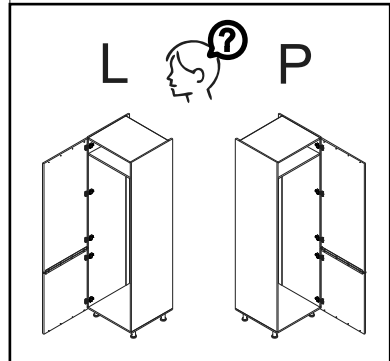

10

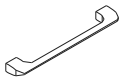

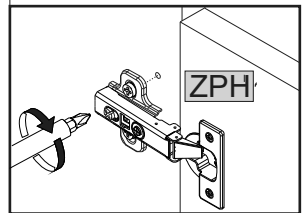
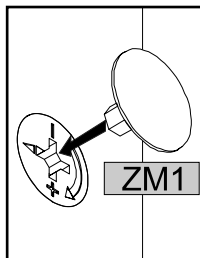
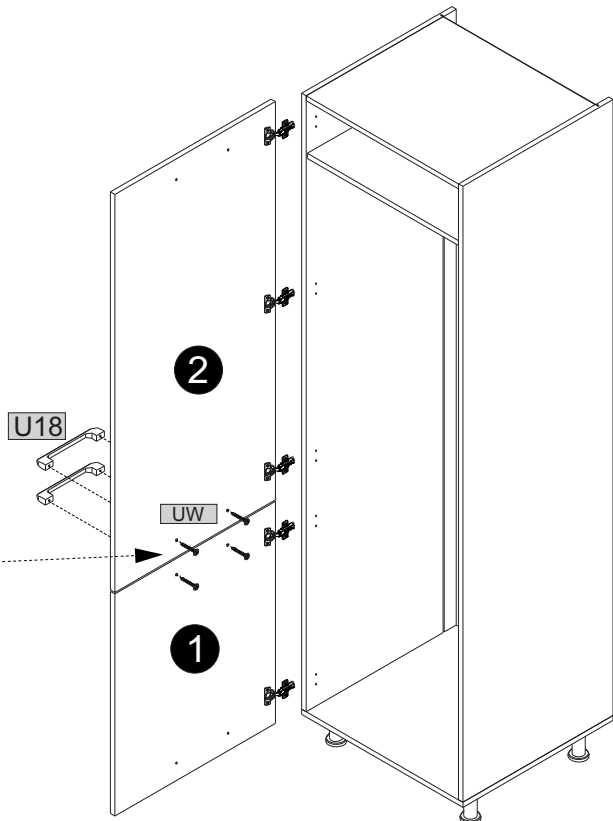
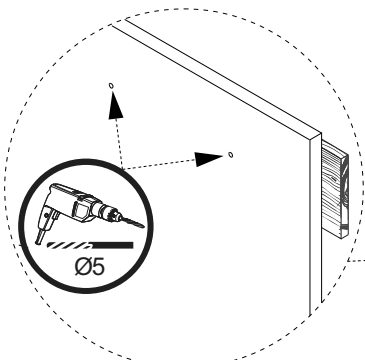

		3,5x25	
WU	4		
			
U18	2		
			
ZM1	4		

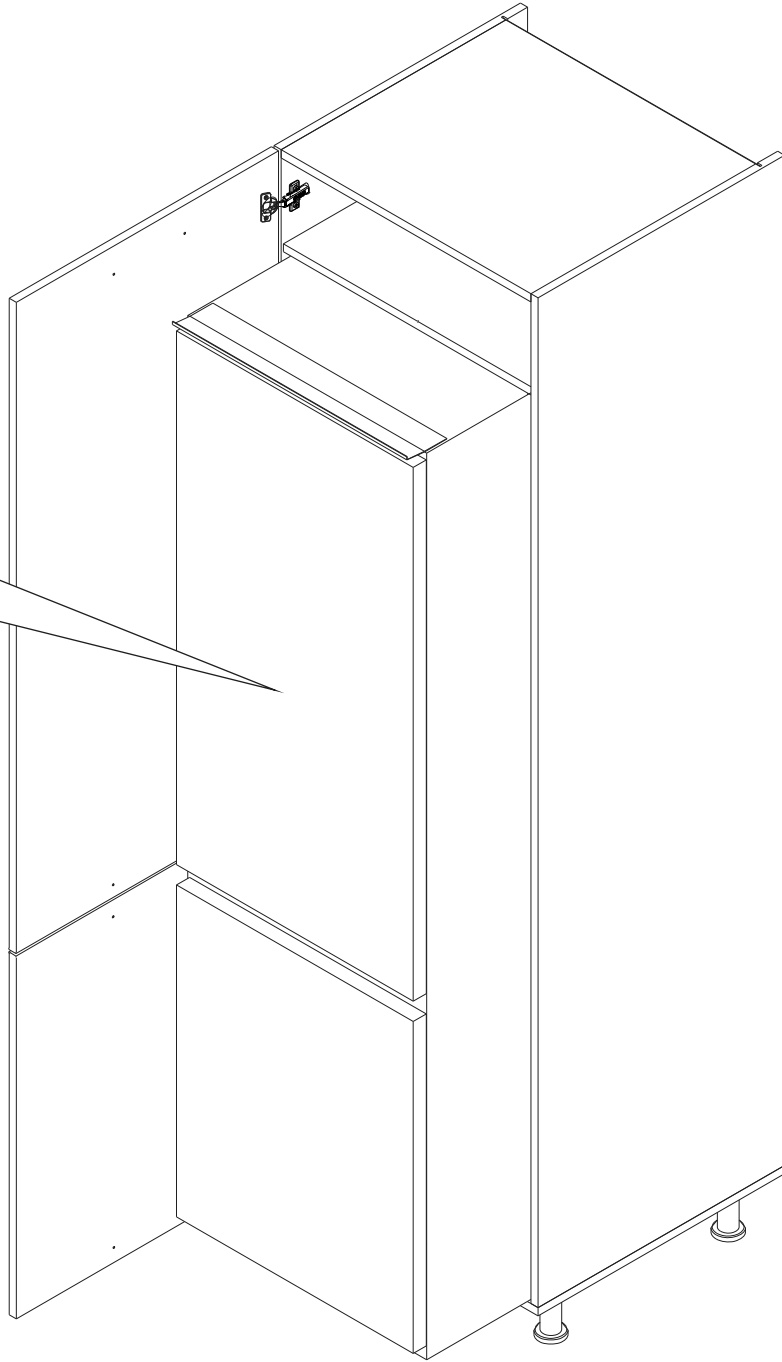
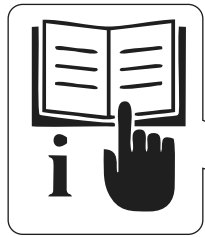

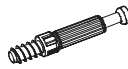

→ 18-20

01

		
ZM1B	KT1	ZM1A
12	16	12

Ø8x35

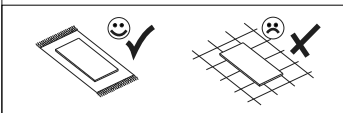
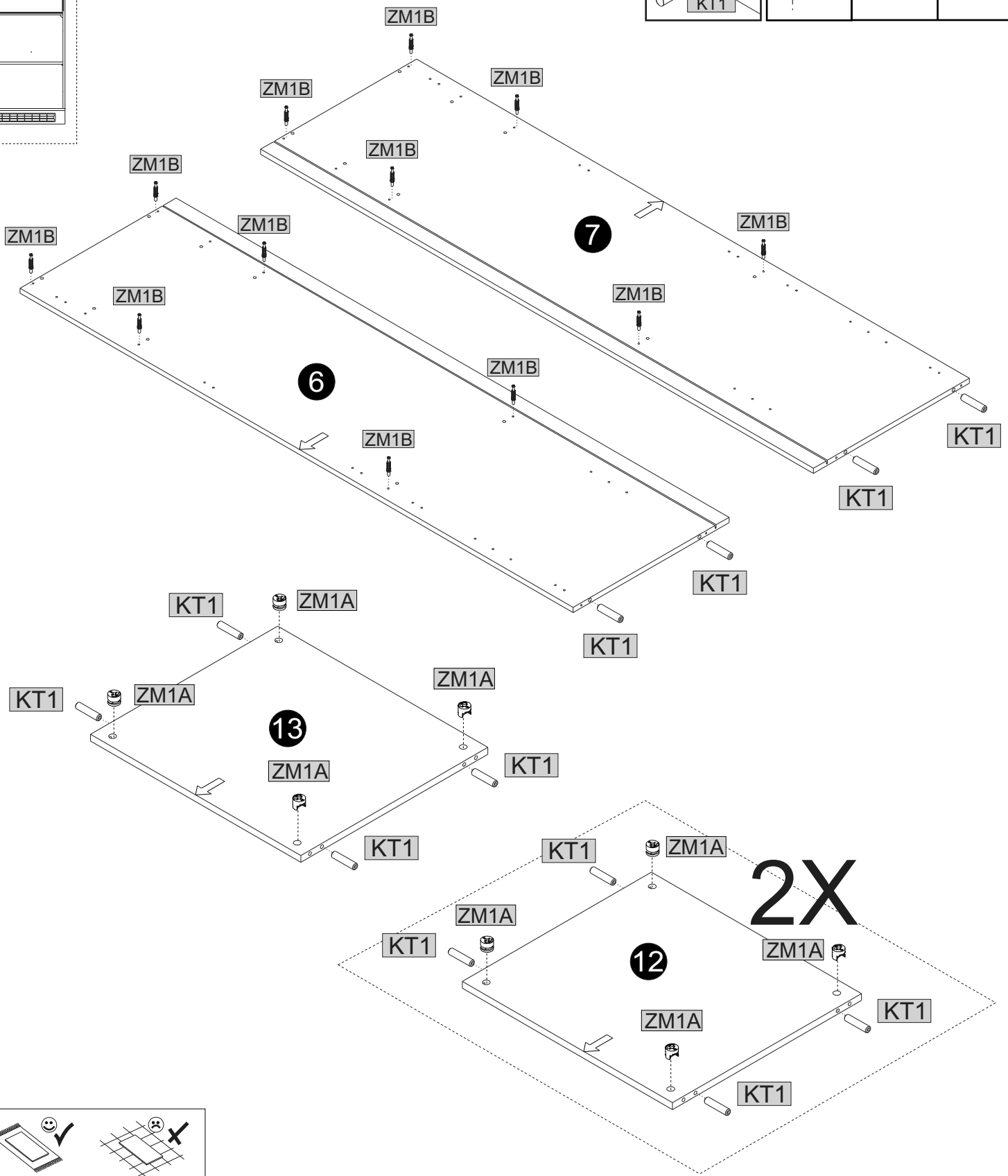
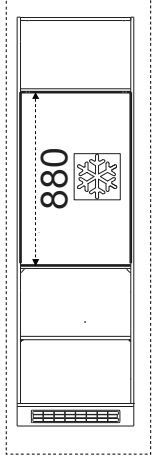
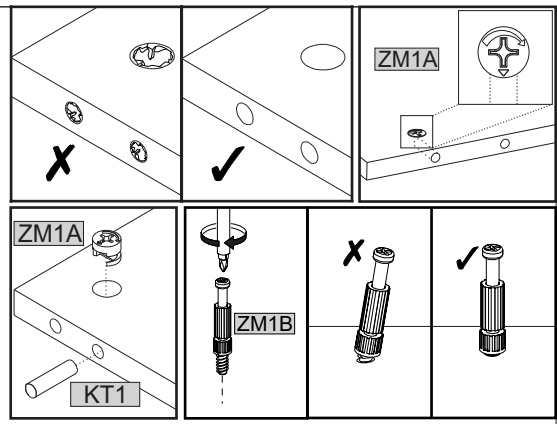

02

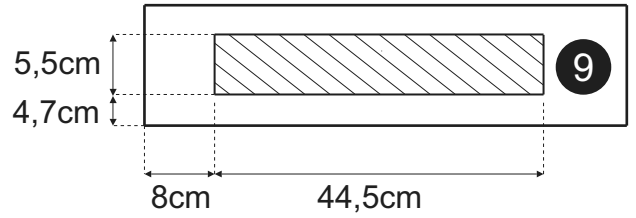
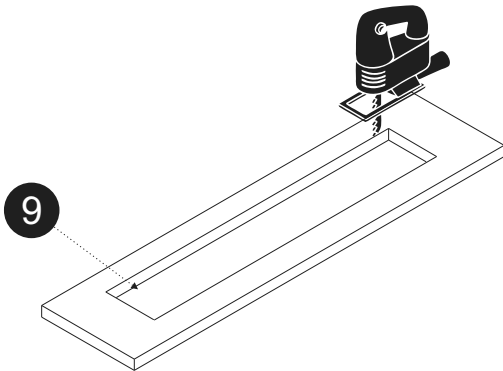
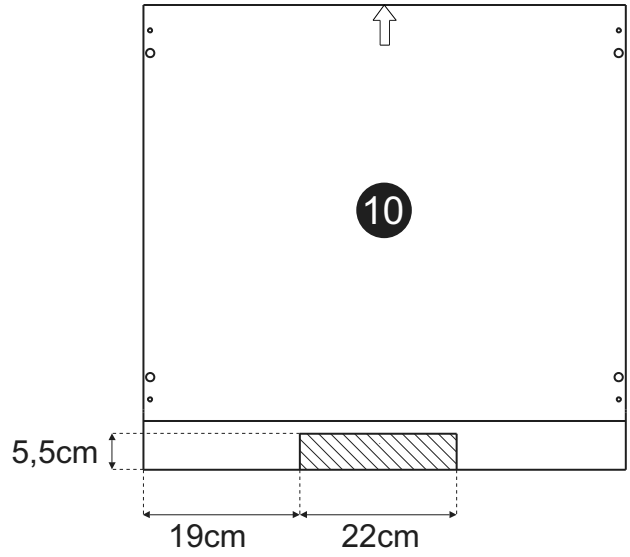
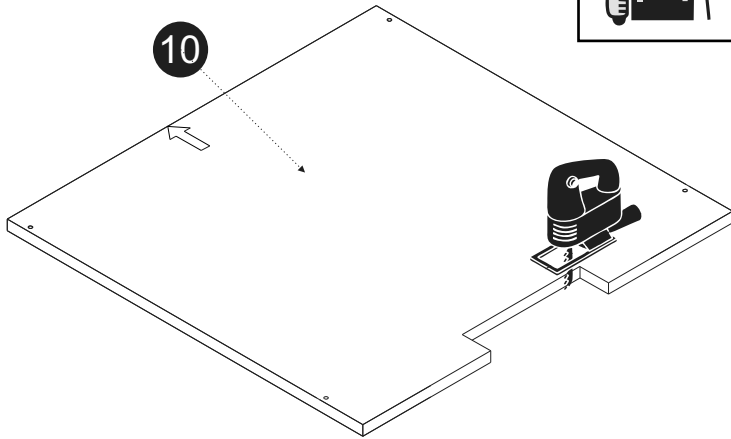

03

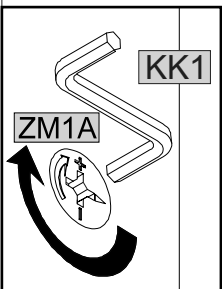
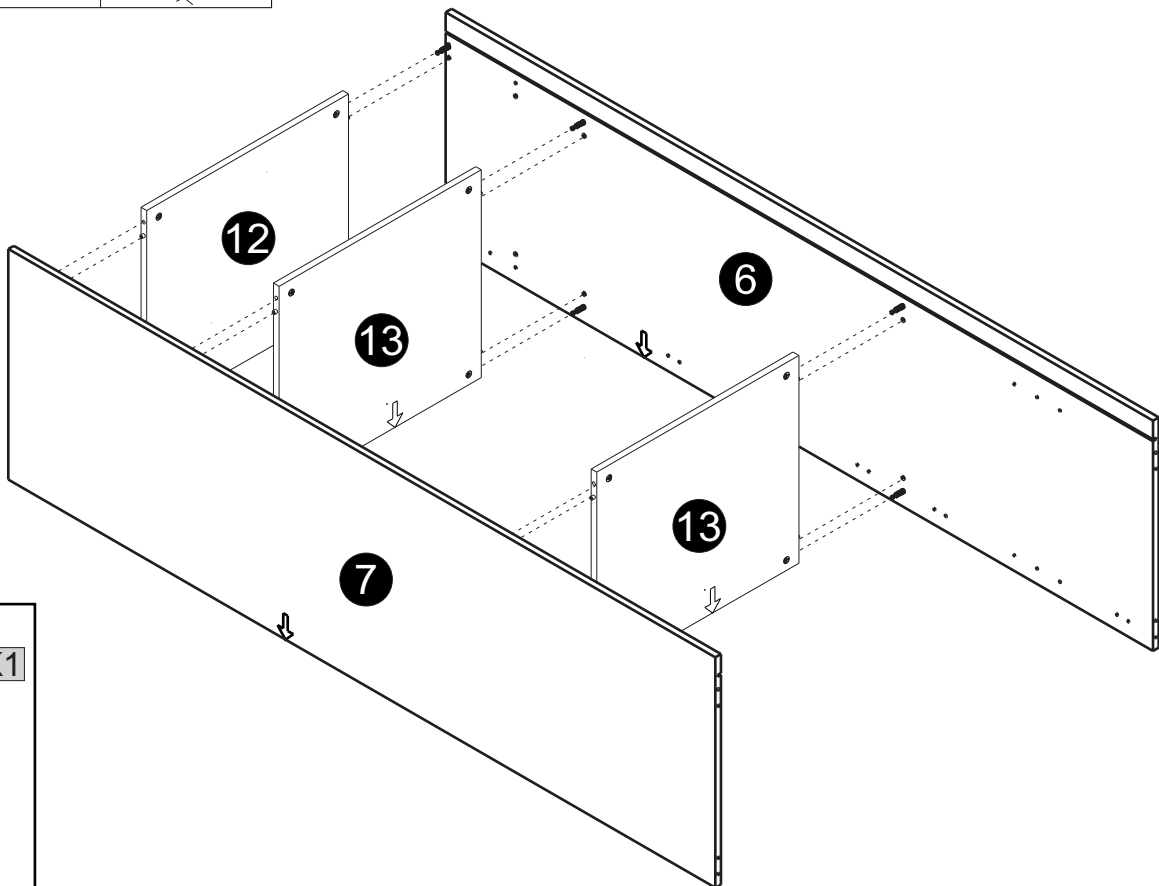
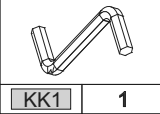
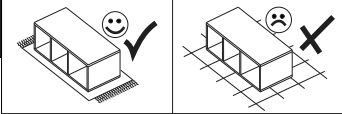

04

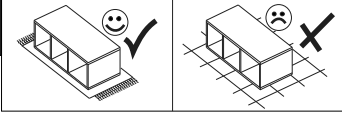

4x16			
W5	16	PMO2	4

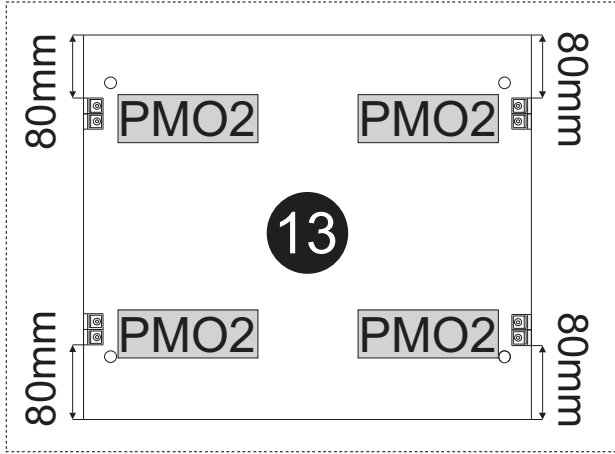
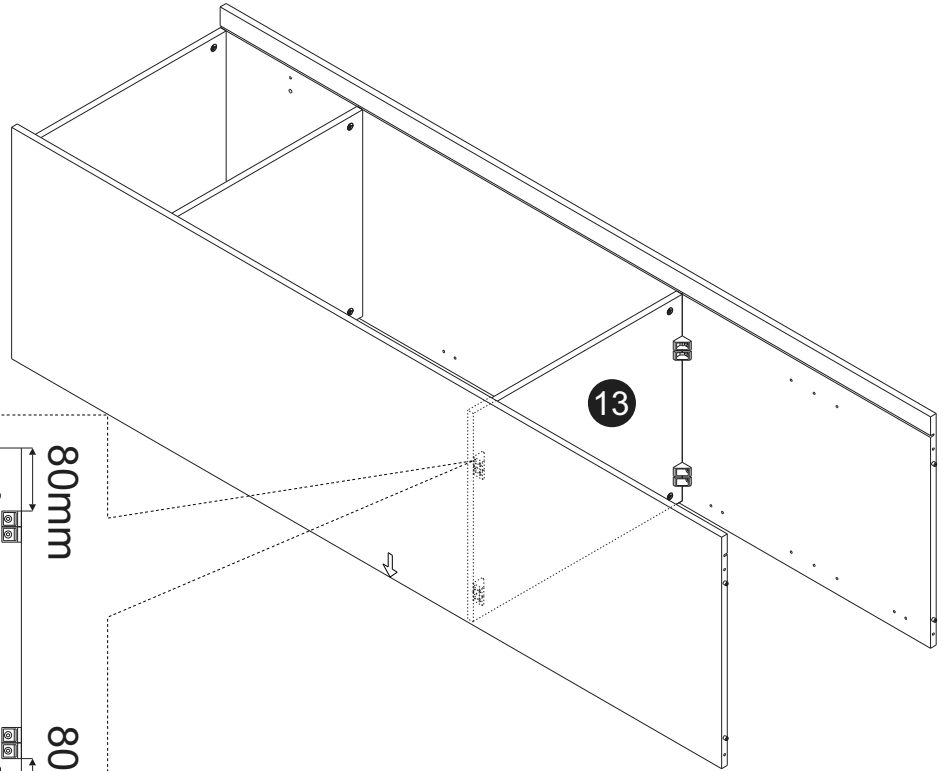
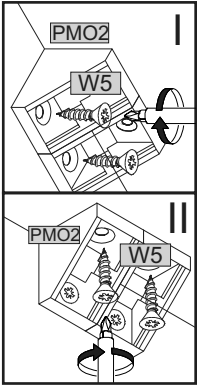

05

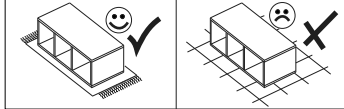

KK1	1	K3	3
		6,4x50	

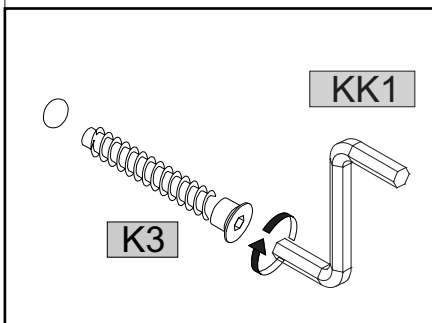
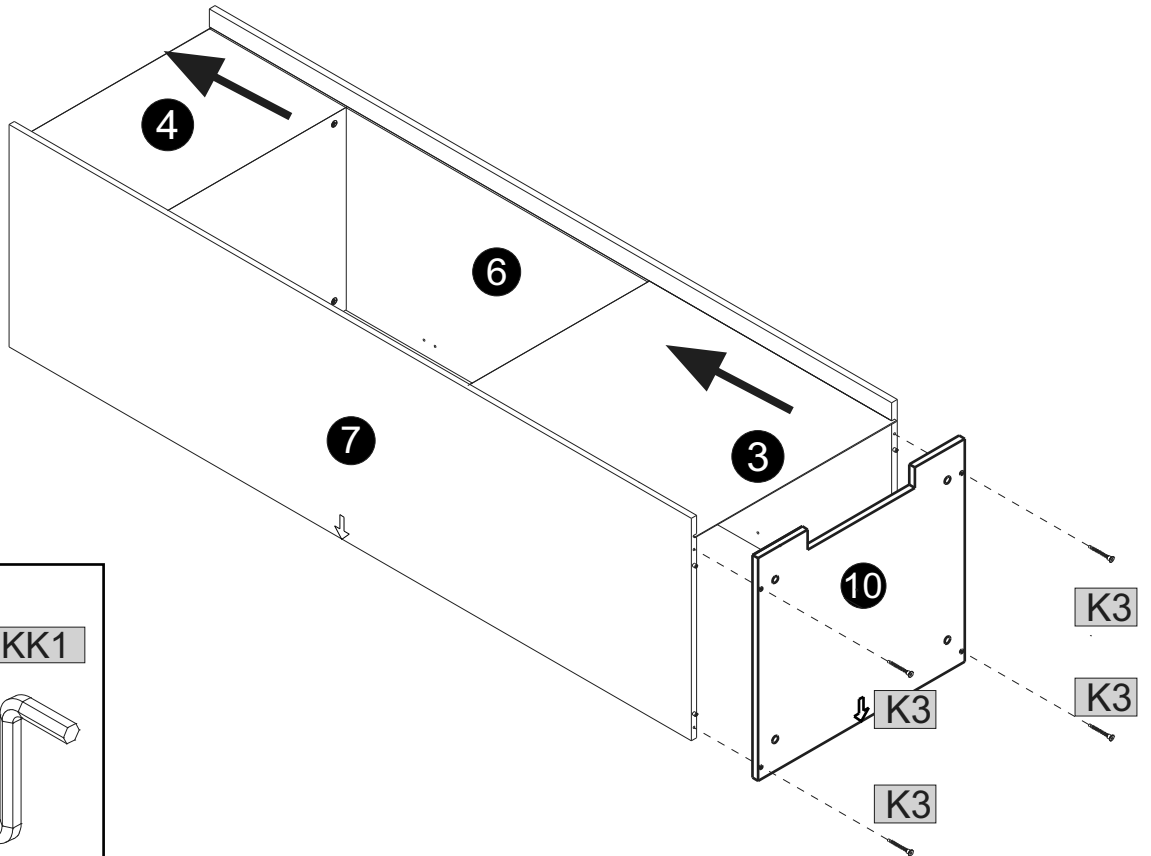

06

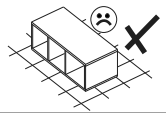
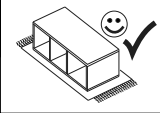

S1

7



W1

3x16

15

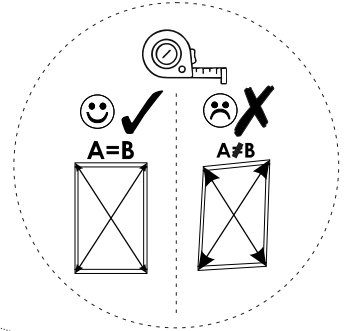
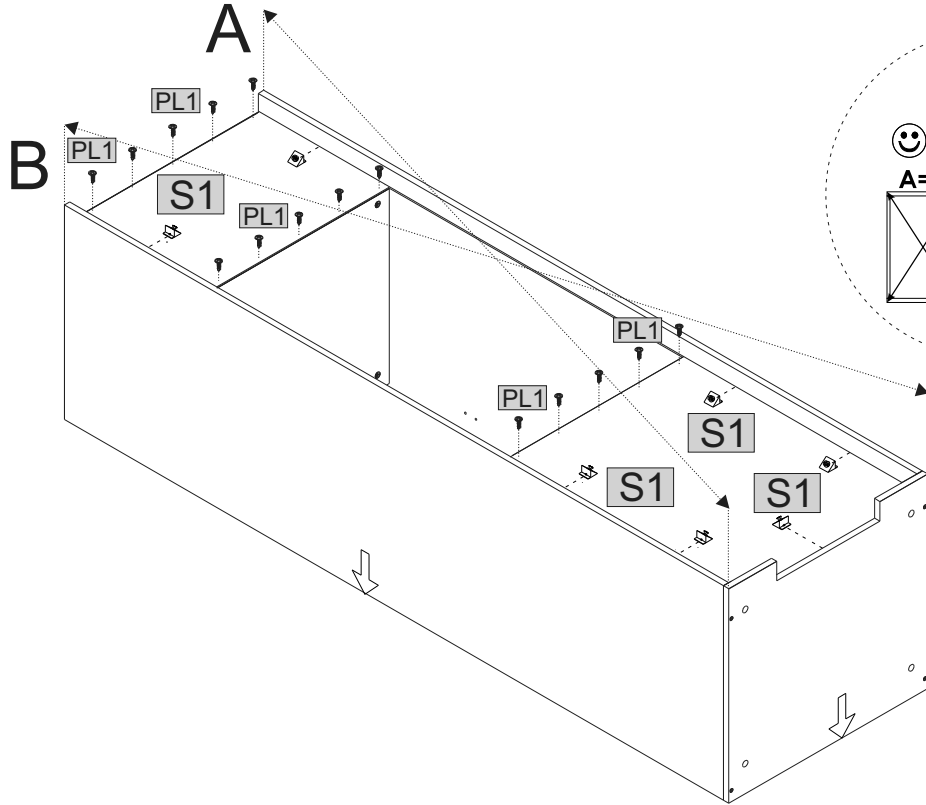
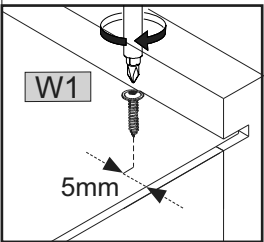
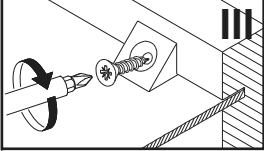
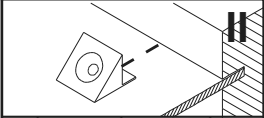
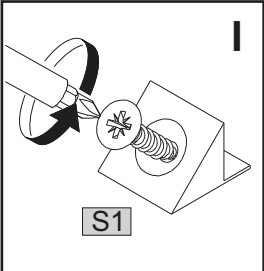

07

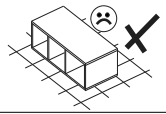
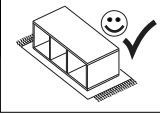

W1

3,5x16

16

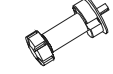

NK1

4

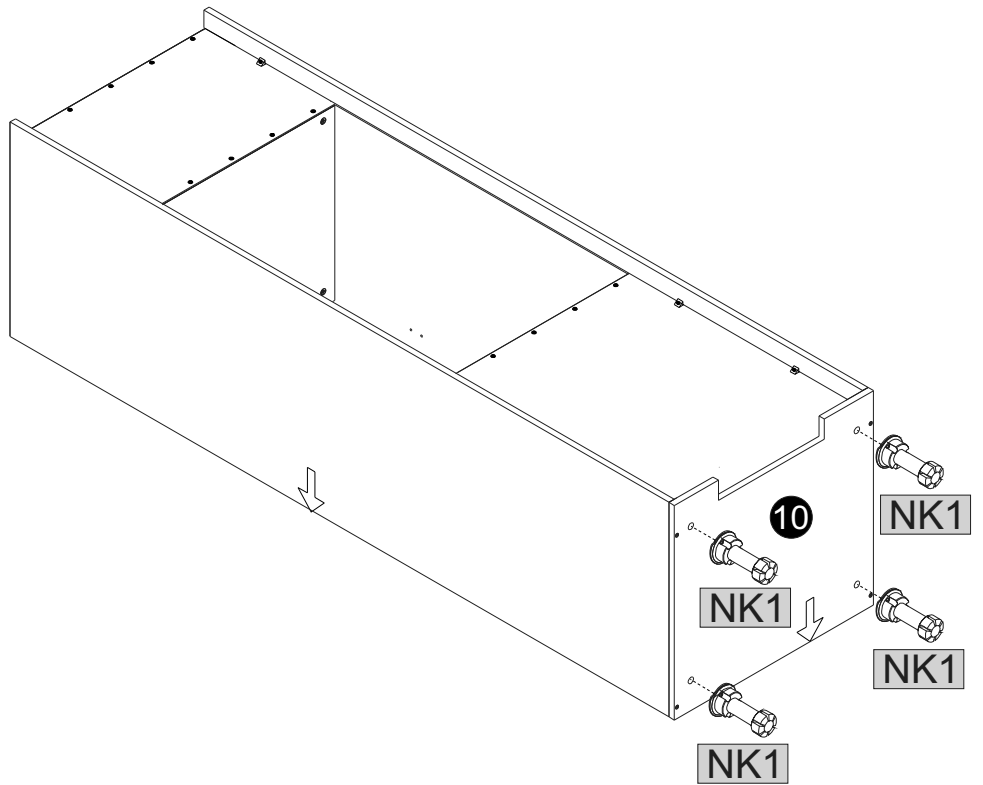
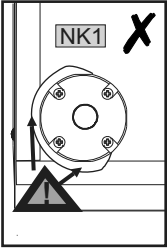
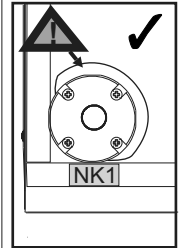
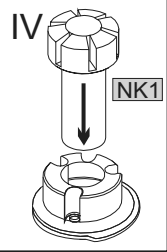
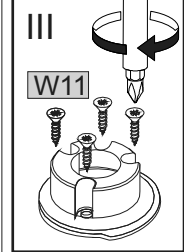
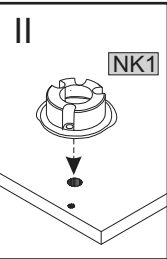
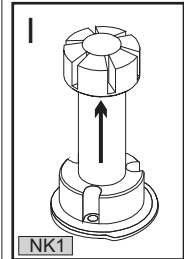

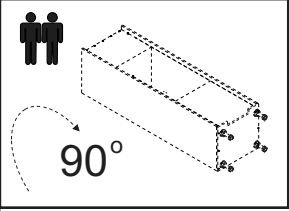

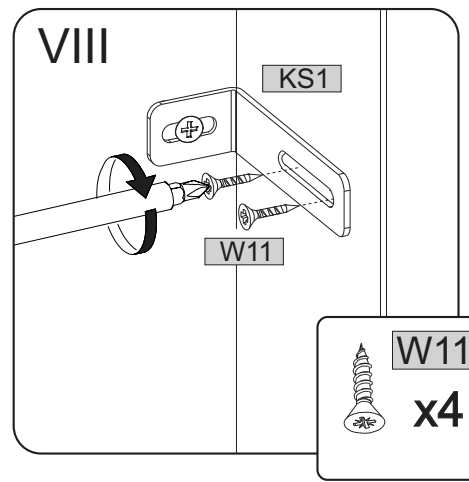
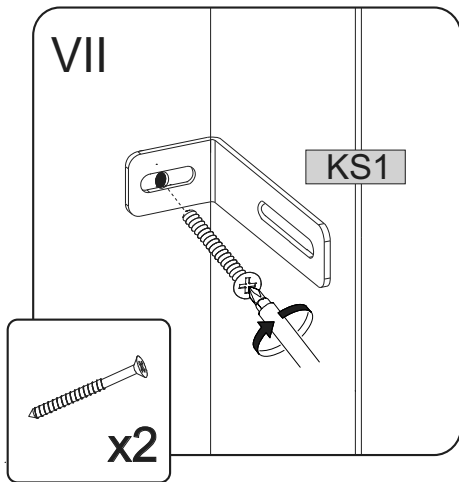
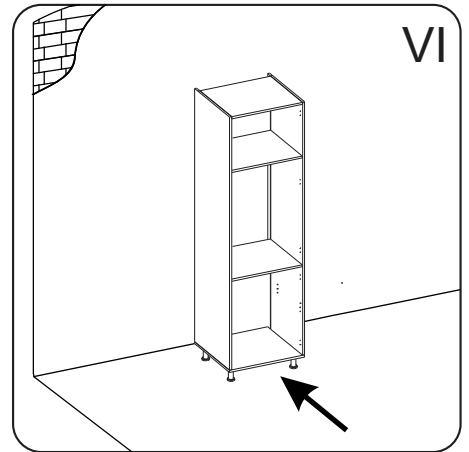
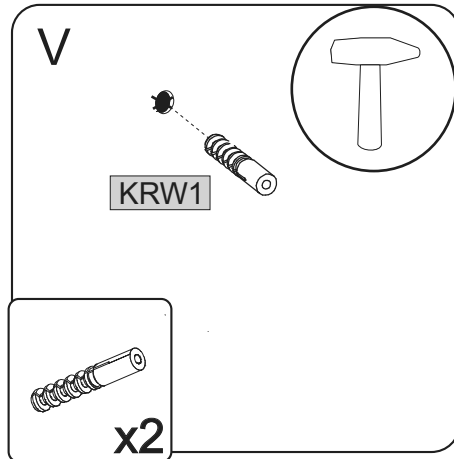
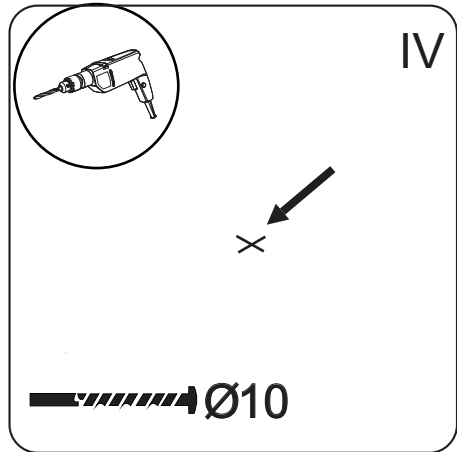
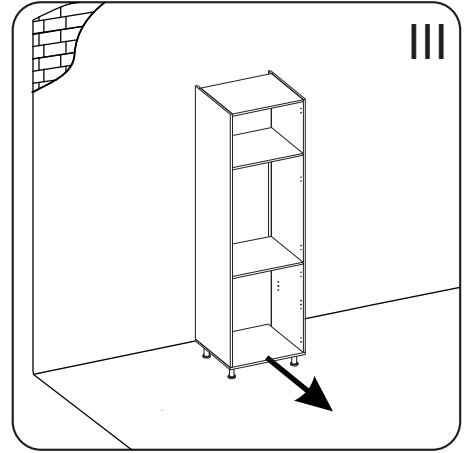
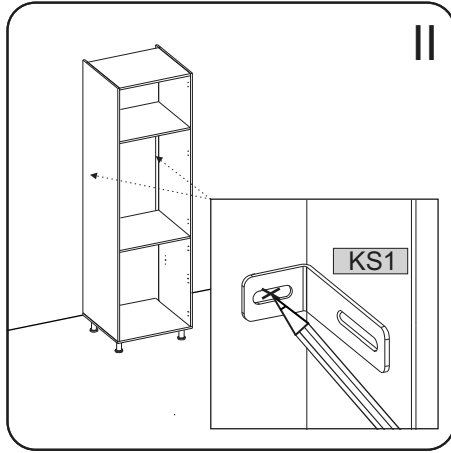
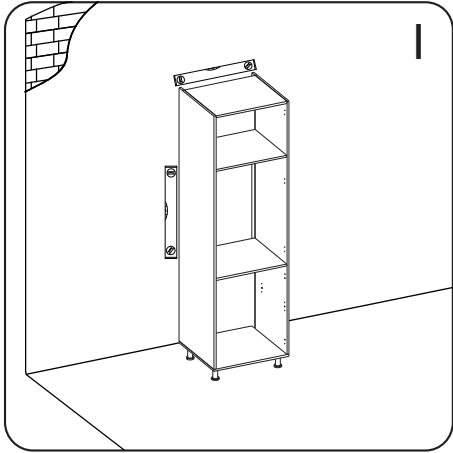

	10x50		6x50		3,5x16		
KRW1	2	KRL1	2	W11	4	KS1	2

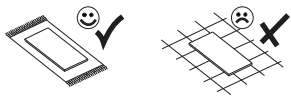

09



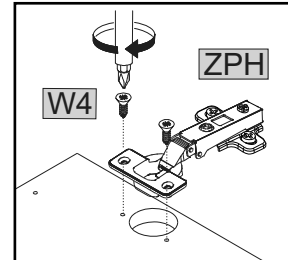
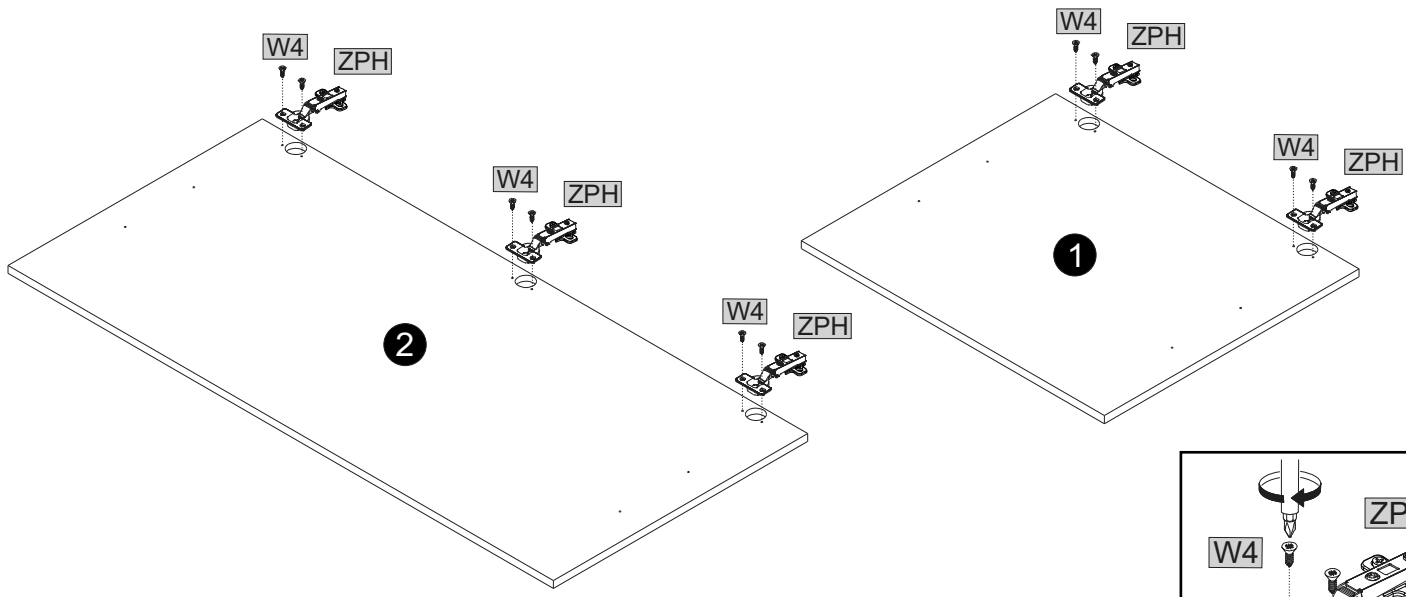

		4x13	
W4	10	ZPH	5

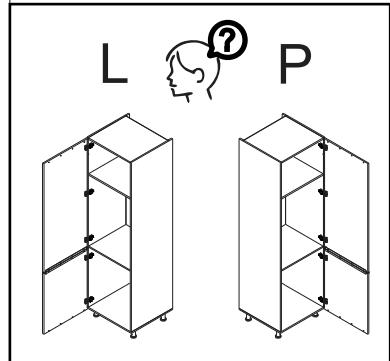

10

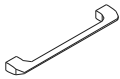

		3,5x25	
WU	4		
			
U18	2		
			
ZM1	8		

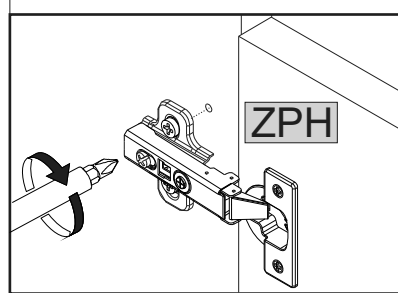
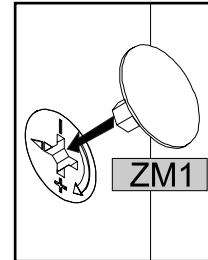
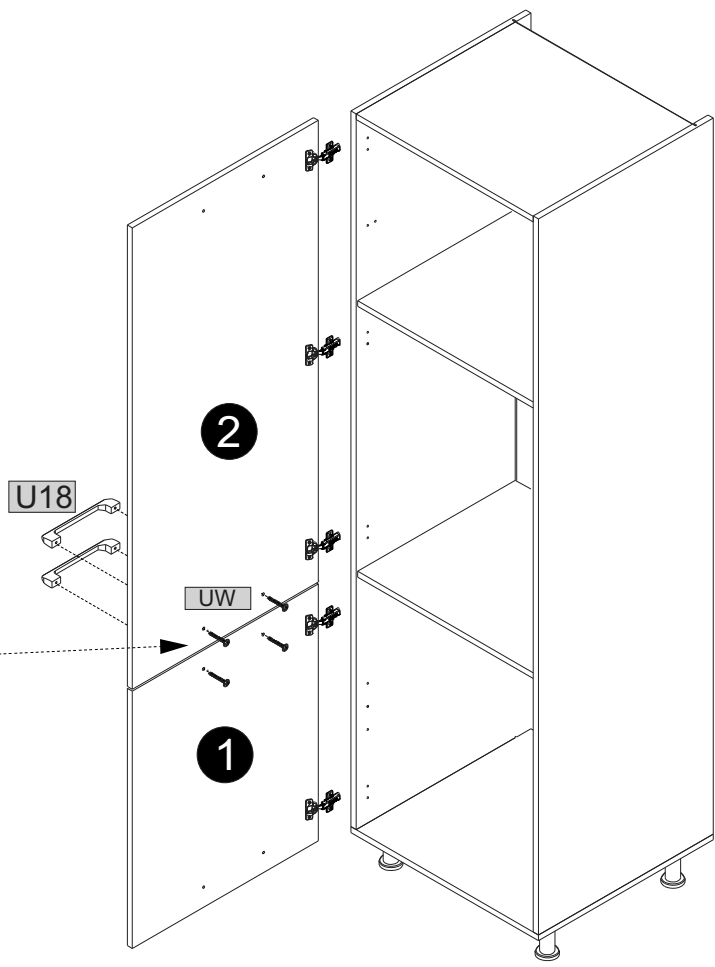
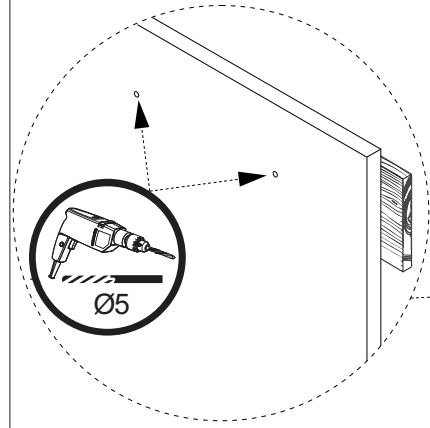



PP

4

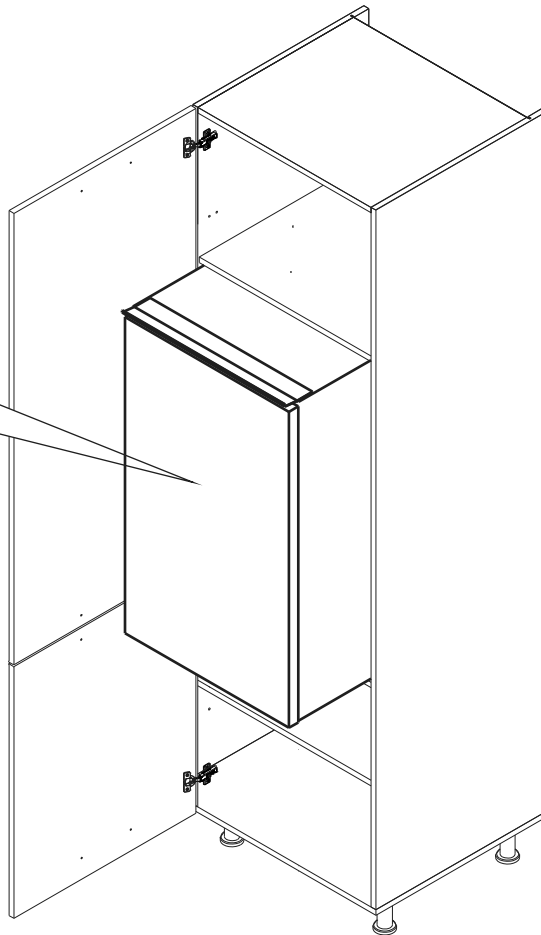
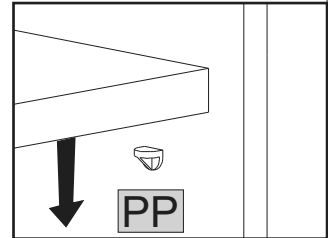
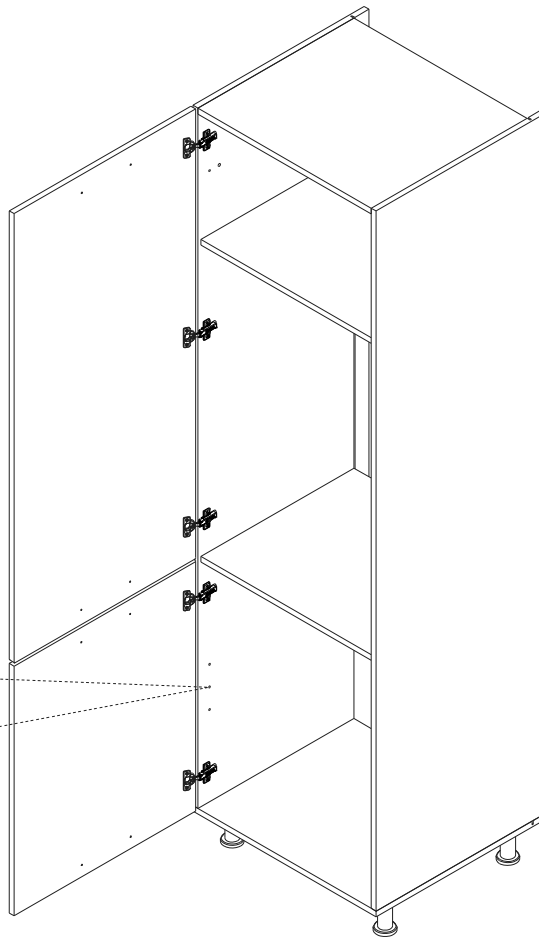
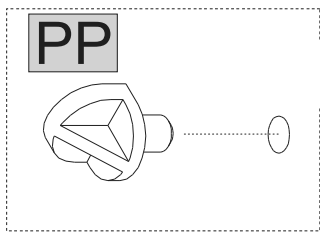

13

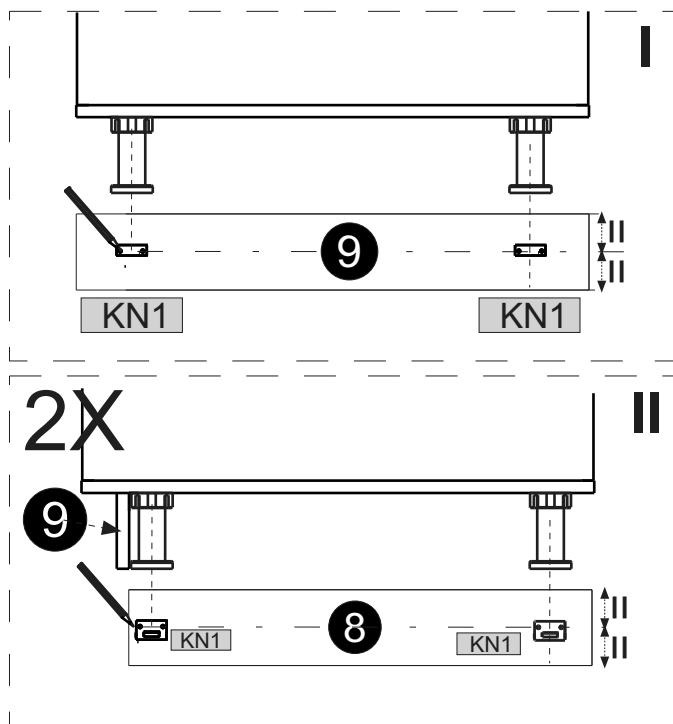
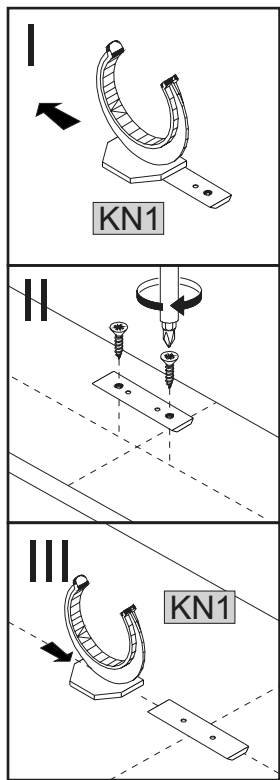

	3,5x16
W11	12
KN1	6

14

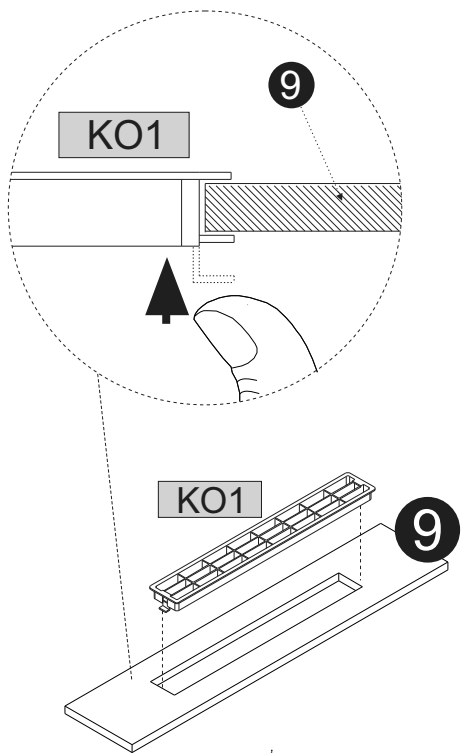
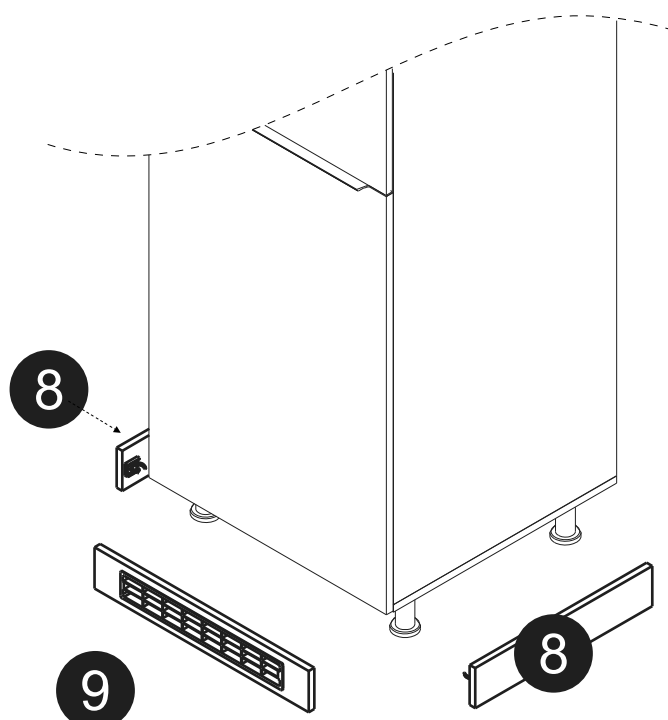

KO1	1

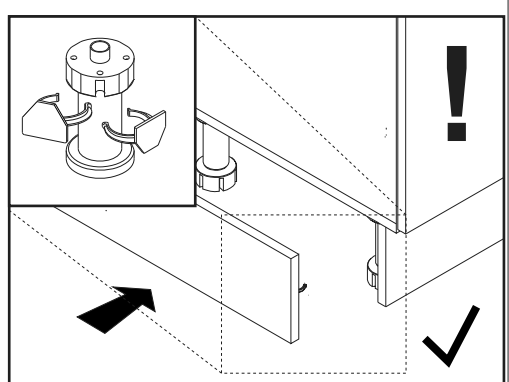
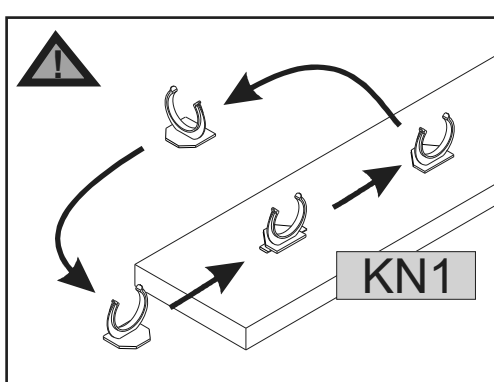
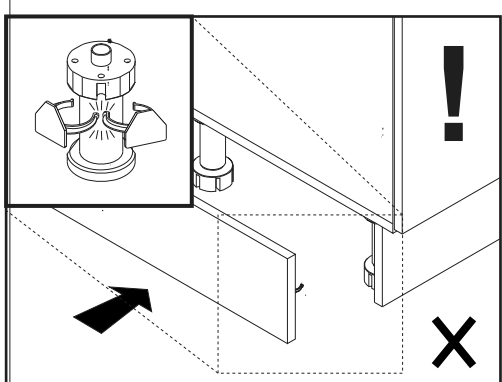

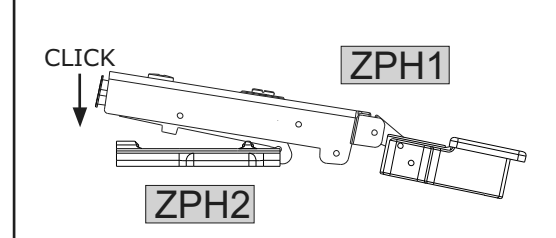
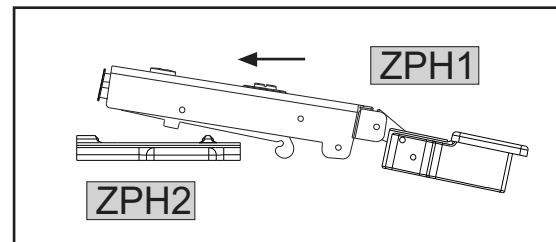
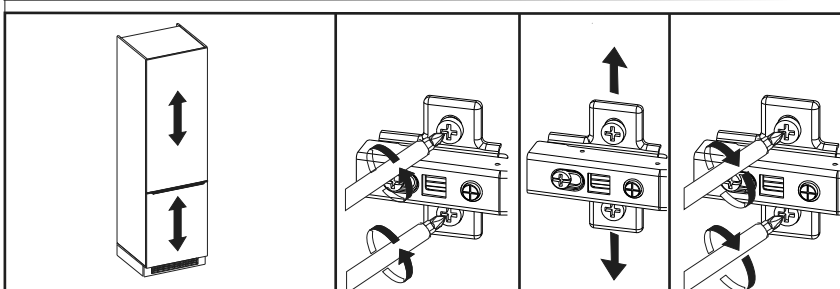
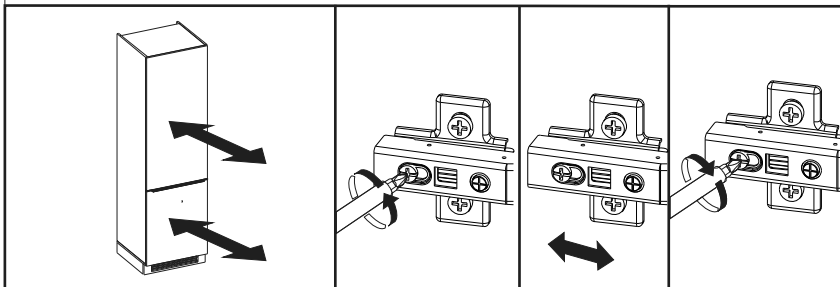
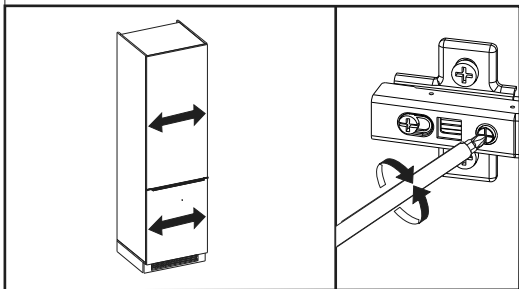
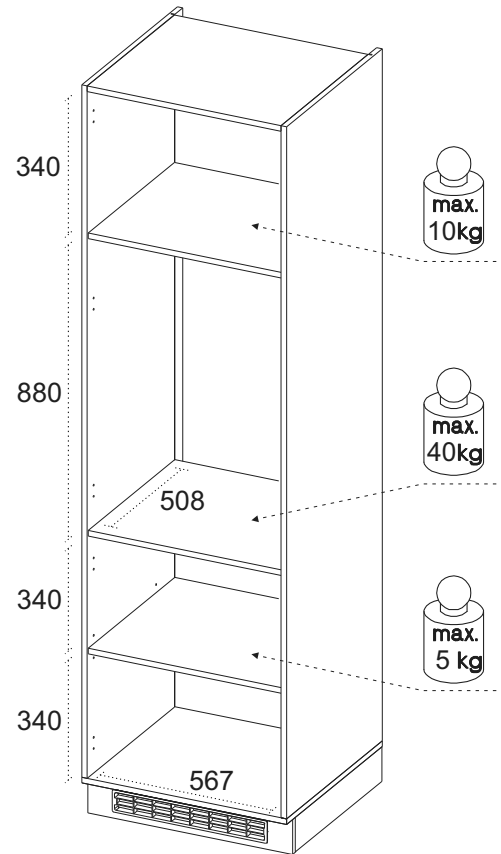
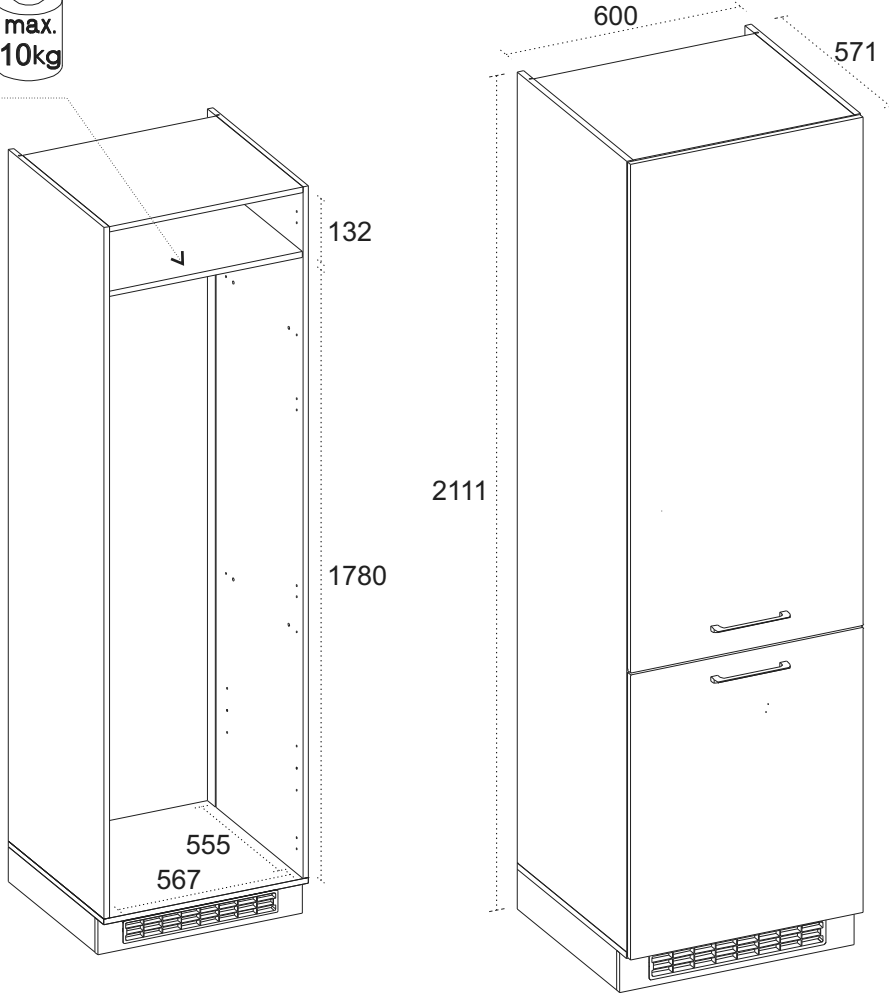
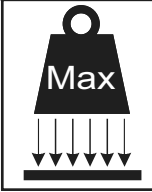

Allgemeine Hinweise

Die Montage einer Einbauküche sollte von entsprechend geschulten Fachkräften durchgeführt werden. Vor der Montage müssen die Montagehinweise gelesen werden.

Spezielle, weiterführende Montageanleitungen und Hinweise liegen den Geräten, Spülen, Beleuchtungen und Sonderausstattungen bei und müssen zusätzlich beachtet werden.

Für die Befestigung von Wandhängeelemente gilt:

Wir legen kein Befestigungsmaterial bei. Bitte prüfen Sie die gegebene Wandbeschaffenheit und wenden Sie sich an den örtlichen Fachhandel zum Erwerb der passenden Dübel / Haken / Aufhängeschienen / Schrauben

Für die Aufhängung können entweder Haken oder Aufhängeschienen verwendet werden.

Die Hängeschränke können bei korrekter Montage mit ca. 40 kg belastet werden. Achten Sie auf eine gleichmäßige Lastverteilung

Bei Nichtbeachtung der Montagehinweise können wir entstandene Schäden keine Haftung übernehmen

Achten Sie darauf bei Einzelschränken, oder der gesamten Küchenzeile eine Kippsicherung anzubringen

Sanitär- und Elektroinstallationen dürfen nur von einer entsprechenden Fachkraft vorgenommen werden

Vor Bohrarbeiten muss geprüft werden, dass an der Stelle des Bohrens keine Leitungen für Gas, Wasser, Strom, Heizung

Abflüsse verlegt wurden

Es dürfen keine verändernden Manipulationen am Zubehör oder an Elektrogeräten vorgenommen werden. Dies gilt insbesondere für Befestigungsbohrungen.

Überprüfen Sie vor der Montage ob alle Anschlüsse vorhanden sind und fachgerecht ausgeführt wurden

Die Küche beinhaltet verschluckbare Kleinteile. Kinder unter 3 Jahre nicht ohne Beaufsichtigung lassen

Empfohlenes Vorgehen bei der Küchenmontage:

Planen Sie den genauen Montageort unter Berücksichtigung Ihrer Sanitär- und Elektroanschlüsse
Prüfen Sie ob Ihr Kühl- Gefriergerät Lüftungsauslässe im Sockelbereich bzw. im Bereich der Arbeitsplatte benötigt
Erwerben Sie ggf. passende Lüftungsgitter im Fachhandel und schneiden Sie den Sockel bzw. die Arbeitsplatten gemäß den Anweisungen des Geräteherstellers aus.
Legen Sie fest, ob Sie die Türen mit Rechts- oder Linksanschlag montieren wollen

Montieren Sie zunächst die Unterschränke und richten Sie diese mit einer Wasserwaage aus.

Erst wenn alles exakt steht, verbinden Sie die einzelnen Schränke mit Schrauben. Damit dabei nichts verrutscht, empfehlen wir Ihnen dringend den Einsatz von zwei Schraubzwingen. Die Schrankoberflächen schützen Sie mit Zulagehölzern vor Eindrücken.

Ermitteln Sie durch exaktes Messen die Positionen der Bohrungen für die Hängebeschläge
Legen Sie die Arbeitsplatte auf die Korpusse, richten Sie sie aus, und fixieren Sie sie mit Zwingen. markieren Sie die Lage und -breite des Herdunterschrankes.

Auf der Unterseite der Arbeitsplatte reißen Sie im markierten Bereich den Herdplattenausschnitt auf. Mitteln Sie sie aus, so dass die Spüle mittig im Unterschrank sitzt und vorne und hinten die Plattenrestbreite gleich wird.

Empfohlenes Vorgehen bei der Küchenmontage:

Bohren Sie in den vier Ecken jeweils ein 10-mm-Loch zum leichteren Einsetzen der Stichsäge, und schneiden Sie den Herdausschnitt entlang Ihrer Risse aus. Arbeiten Sie immer von der Plattenunterseite, damit die Plattenoberfläche durch die Stichsäge nicht ausfasert. Schalten Sie dazu auch den Pendelhub an Ihrer Stichsäge, sofern vorhanden, aus.
Zum Schutz der Holzteile können Sie rundum die Sockelteile eine Silikonnaht ziehen

Empfohlenes Vorgehen bei der Küchenmontage:

Bohren Sie in den vier Ecken jeweils ein 10-mm-Loch zum leichteren Einsetzen der Stichsäge, und schneiden Sie den Herdausschnitt entlang Ihrer Risse aus. Arbeiten Sie immer von der Plattenunterseite, damit die Plattenoberfläche durch die Stichsäge nicht ausfasert. Schalten Sie dazu auch den Pendelhub an Ihrer Stichsäge, sofern vorhanden, aus.
Zum Schutz der Holzteile können Sie rundum die Sockelteile eine Silikonnaht ziehen

DE	<p>Warnhinweis: Wenn der Ware Dübel und Schrauben beiliegen, sind sie ausschließlich zur Anwendung an Wänden aus massiven und einheitlichen Materialien bestimmt, um ein Umkippen zu verhindern. Vergewissern Sie sich vor dem Bohren, dass sich keine Gas-, Wasser-, oder Stromleitungen an der Bohrstelle befinden. Zur Befestigung an anderen Wänden müssen Spezialdübel verwendet werden. Erkundigen Sie sich im Handel nach den für die jeweilige Wandbeschaffenheit geeigneten Schrauben und oder Dübel. Für eine unsachgemäße Montage und dadurch entstandene Schäden übernimmt der Hersteller keine Haftung. Bitte alle Schrauben in regelmäßigen Abständen überprüfen und nachziehen.</p>
FR	<p>Avertissement : Pour éviter le basculement accidentel du meuble, la fixation du meuble au mur est obligatoire. Si des chevilles et des vis sont fournies avec l'article, elles sont exclusivement destinées à être utilisées sur des murs en matériaux massifs et homogènes pour éviter tout basculement. Avant de percer, assurez-vous qu'aucune conduite de gaz, d'eau ou d'électricité ne se trouve à l'endroit où vous percez. Pour la fixation sur d'autres murs, il faut utiliser des chevilles spéciales. Renseignez-vous en magasin sur les vis et les chevilles adaptées à chaque type de mur. Le fabricant décline toute responsabilité en cas de montage incorrect et de dommages qui en résulteraient. Veuillez vérifier et resserrer toutes les vis à intervalles réguliers. ATTENTION ! Les meubles contenant des panneaux à base de bois (panneaux de particules, panneaux de fibres, contreplaqué...) peuvent émettre des substances polluantes dans l'air intérieur. Il est ainsi recommandé, après l'installation du meuble dans son logement, d'aérer fréquemment la pièce concernée pendant au moins quatre semaines afin de réduire son exposition aux polluants émis par le meuble LED: Ce luminaire est un produit de décoration. Ce luminaire ne convient pas pour l'éclairage principal d'une pièce de la maison.</p>
UK	<p>Warning: If dowels and screws are included with the product, they are only intended for use on walls made of solid and uniform materials to prevent them from tipping over. Before drilling, make sure that there are no gas, water or electricity pipes at the drilling site. Special anchors must be used for fastening to other walls. Ask in the trade for the screws and or dowels suitable for the respective wall condition. The manufacturer accepts no liability for improper installation and any resulting damage. Please check and retighten all screws at regular intervals.</p>
IT	<p>Avvertenza: Se con il prodotto sono forniti tasselli e viti, questi sono destinati esclusivamente all'utilizzo su pareti realizzate con materiali solidi ed uniformi, per evitare il ribaltamento. Prima di eseguire i fori assicurarsi che non ci siano condutture di gas, acqua o elettriche vicino al punto di perforazione. Per il fissaggio ad altre pareti è necessario utilizzare tasselli speciali. Chiedere al proprio rivenditore le viti e/o tasselli adatti al tipo di parete in questione. Il produttore non si assume alcuna responsabilità in caso di montaggio improprio e dei danni che ne derivano. Controllare e serrare tutte le viti a distanza regolare.</p>
PL	<p>Ostrzeżenie: Jeżeli do towaru dołączone są kołki i śruby, są one przeznaczone wyłącznie do stosowania na ścianach wykonanych z solidnych i jednolitych materiałów, aby zapobiec przewróceniu. Przed rozpoczęciem wiercenia należy upewnić się, że w miejscu wiercenia nie są ułożone rury gazowe, wodociągowe lub przewody elektryczne. Do mocowania do innych ścian należy stosować kołki specjalne. O śruby lub kołki odpowiednio dla konstrukcji danej ściany należy pytać w sklepach specjalistycznych. Producent nie ponosi odpowiedzialności za nieprawidłowy montaż i wyniki z tego tytułu szkody. Wszystkie śruby należy regularnie sprawdzać i dokręcać.</p>
ESP	<p>Advertencia: En el caso de incluirse tacos y tornillos con la mercancía, estos están previstos únicamente para su uso en paredes macizas y homogéneas a fin de evitar un posible vuelco. Antes de taladrar, asegúrese de que por el punto de perforación no pasan tuberías de gas o agua o cables eléctricos. Para la fijación en otro tipo de paredes deben utilizarse tacos especiales. Pregunte en la tienda por los tornillos o tacos adecuados para las características de la pared en cuestión. El fabricante no asume ninguna responsabilidad por un montaje incorrecto ni por los daños resultantes del mismo. Compruebe todos los tornillos en intervalos regulares y apriételes.</p>
CZ	<p>Výstražné upozornění: Pokud jsou k výrobku přiloženy hmoždinky a šrouby, jsou určeny výhradně pro použití do stěn zhotovených z masivních a homogenních materiálů, a to za účelem zajištění proti převrácení. Před vrtáním se ujistěte, že se v místě vrtání nenachází vedení plynu, vody nebo elektřiny. Pro připevnění k jiným stěnám je nutné použít speciální hmoždinky. Informujte se v obchodě o hmoždinkách a/nebo šroubech vhodných pro příslušnou strukturu stěny. Výrobce nenes odpovědnost za nesprávnou montáž a za škody jí způsobené. Všechny šrouby pravidelně kontrolujte a dotahujte.</p>
SK	<p>Informácia o nebezpečenstve: Ak sú k tovaru priložené príchytky a skrutky, sú určené výlučne na použitie na stenách z masívnych a jednotných materiálov, aby sa zabránilo prevráteniu. Pred vrtaním sa uistite, že sa na vrtanom mieste nenachádzajú žiadne plynové, vodovodné alebo elektrické vedenia. Na upevnenie na iných stenách musia byť použité špeciálne príchytky. Spýtajte sa v predajni na skrutky a/alebo príchytky vhodné pre príslušný typ steny. Výrobca nepreberá ručenie za nesprávnu montáž a tým vzniknuté škody. Všetky skrutky v pravidelných intervaloch kontrolujte a dotiahnite.</p>
HU	<p>Figyelmeztetés: Amennyiben a termék csomagolásába tipliket és csavarokat is tartalmaz, azok kizárólag masszív, egységes anyagból készült falakon használhatók, a felborulás megakadályozásának céljából. A fúrás előtt bizonyosodjon meg arról, hogy a fúrás helyén nem található gáz-, víz- vagy elektromos vezeték. Egyéb falakra történő rögzítéshez speciális tiplik szükségesek. Az egyes faltípusokkal használható megfelelő csavarokkal és/vagy tiplikkel kapcsolatos információkért kérjük, forduljon forgalmazójához. A nem szakszerű szerelésért és az abból keletkező károkért a gyártót semmilyen felelősség nem terheli. Minden csavart ellenőrizzen és rögzítsen rendszeresen.</p>
BG	<p>Предупредително указание: Ако в окомплектовката на доставката на стоката са включени дюбели и винтове, те са предназначени единствено за употреба върху стени от масивни и еднородни материали, за да се предотврати преобръщане. Преди пробиване се уверете, че на мястото на пробиване няма тръби за газ, за вода или електрически проводници. За закрепване към други стени трябва да се използват специални дюбели. Информирайте се в търговската мрежа относно подходящите винтове и/или дюбели за съответната конструкция на стената. Производителят не поема отговорност за неправилен монтаж и възникнали в резултат на това щети. Моля, проверявайте и затягвайте всички винтове на редовни интервали.</p>
TR	<p>Uyarı: Ürün paketinde dübel ve vida varsa, bunlar devrilmeyi önlemek amacıyla, sadece masif ve yekpare malzemelerden imal edilmiş duvarlardaki kullanım için öngörülmüştür. Matkapla delik açmadan önce delme noktasında gaz, su veya elektrik hatlarının olmadığından emin olun. Ürünü başka duvarlara sabitlemek için özel dübeller kullanılmalıdır. Piyasadaki satıcılardan ilgili duvarın özelliğine uygun vidalar ve dübeller hakkında bilgi alın. Usulüne aykırı bir montaj ve bu nedenle oluşmuş hasarlar için üretici sorumluluk almamaktadır. Lütfen tüm vidaları düzenli aralıklarla kontrol edip tekrar sıkın.</p>

PT	Advertência: Caso o produto venha com buchas e parafusos incluídos, os mesmos são exclusivamente destinados à fixação em paredes de materiais sólidos e uniformes, para evitar que o produto tombe. Antes de iniciar a perfuração, certifique-se de que não existem canalizações de gás, água ou fios elétricos a passar no local dos furos. Para a fixação nouro tipo de paredes, têm de ser utilizadas buchas especiais. Informe-se junto de um comerciante especializado sobre os parafusos e buchas a utilizar na parede específica. O fabricante não assume qualquer responsabilidade no caso de uma montagem inadequada e qualquer dano daí resultante. Verifique e volte a apertar todos os parafusos regularmente.
SI	Opozorilo: če so blagu priloženi zidni vložki in vijaki, so ti namenjeni izključno za uporabo na stenah iz masivnih in enotnih materialov, da se prepreči prevrnitev. Pred vrtnanjem se prepričajte, da na mestu vrtnanja ni plinskih, vodnih ali električnih napeljav. Za pritrditev na druge stene je treba uporabljati posebne zidne vložke. Pozanimajte se v trgovini o vijakih in/ali zidnih vložkih, primernih za posamezno sestavo stene. Proizvajalec ne prevzema jamstva za nepravilno montažo in zaradi tega nastalo škodo. Vse vijake redno preverjajte in naknadno privijajte.
NL	Waarschuwing: Indien er bij het product pluggen en schroeven zijn meegeleverd, zijn deze uitsluitend bestemd om in muren van massieve en homogene materialen te gebruiken om te voorkomen dat het product kantelt. Controleer voordat u begint of er geen gas-, water- of elektriciteitsleidingen lopen waar u gaat boren. Voor de bevestiging aan andere soorten muren moeten speciale pluggen worden gebruikt. Informeer in de winkel welke schroeven en/of pluggen geschikt zijn voor de desbetreffende muur. De fabrikant is niet aansprakelijk voor een onjuiste montage en de daardoor ontstane schade. Controleer regelmatig of alle schroeven nog goed vastzitten en draai ze zo nodig vast.
SRB	Upozoravajuća napomena: Ako su uz robu priloženi tiplovi i zavrtnji, isti su namenjeni isključivo za primenu na zidovima od kompaktnih i homogenih materijala, kako bi se sprečilo prevrtanje. Pre bušenja se uverite da se na mestu bušenja ne nalaze vodovi za gas, vodu ili struju. Za fiksiranje na drugačijim zidovima moraju da se upotrebe specijalni tiplovi. Raspitajte se u trgovini o zavrtnjima i/ili tiplovima koji su adekvatni za dotičnu teksturu zida. Proizvođač ne preuzima nikakvu odgovornost za nestručnu montažu i štete koje su nastale na taj način. Sve zavrtnje kontrolišite i dotežite u redovnim intervalima.
RO	Indicație de avertizare: Dacă produsul este livrat împreună cu șuruburi și dibluri, acestea sunt destinate exclusiv utilizării pe pereți construiți din materiale masive și uniforme, pentru a preveni răsturnarea produsului. Înainte de a realiza găurile, asigurați-vă că nu există conducte de gaz, apă sau electricitate în locul pe care doriți să-l găuriți. Pentru prinderea pe alte tipuri de pereți, trebuie să utilizați dibluri speciale. Interesați-vă la magazinul specializat, pentru a găsi șuruburile și/sau diblurile potrivite pentru peretele dvs. Producătorul nu este responsabil, în cazul unui montaj necorespunzător pentru daunele rezultate. Vă rugăm să verificați toate șuruburile la intervale regulate și să le strângeți.
HR	Upozorenje: Ako su uz proizvod priložene tiple i vijci, oni su namijenjeni isključivo za korištenje na zidovima od čvrstih i jednoličnih materijala kako bi se spriječilo prevrtanje. Prije bušenja provjerite da na mjestu bušenja nema električnih vodova, plinskih ili vodovodnih cijevi. Za pričvršćivanje na ostale zidove potrebno je koristiti posebne tiple. Prilikom kupnje raspitajte se kod svog prodavača o vijcima i tiplama koji su prikladni za odgovarajuću zidnu strukturu. Proizvođač ne odgovara za štete nastale uslijed nepravilne montaže. Sve vijke potrebno je redovito provjeravati i zategnuti.
SE	Varning: Om plugg och skruvar följer med produkten är de endast avsedda för väggar av massivt och enhetligt material för att förhindra att produkten vippar. Försäkra dig om att inga gas-, vatten- eller elledningar befinner sig på platsen som du ska borra innan du börjar. För fastsättning i väggen måste specialplugg användas. Informera dig i en butik om vilka skruvar och plugg som passar till vilken vägg. För en felaktig montering och skador som uppstår på grund av detta tar tillverkaren inget ansvar. Kontrollera och dra åt alla skruvar med jämna mellanrum.
RUS	Предупреждение: Если изделие поставляется вместе с дюбелями и шурупам, они предназначены исключительно для использования на стенах из монолитных и однородных материалов, чтобы предотвратить возможное обрушение. Перед началом сверления убедитесь, что на месте сверления нет газопровода, водопровода или электропроводки. Для крепления к другим стенам необходимо использовать специальные дюбели. Узнайте у продавца, какие шурупы или дюбели подходят для соответствующей структуры стены. Производитель не несет ответственности за неправильный монтаж и вызванный им ущерб. Регулярно проверяйте и подтягивайте все шурупы.
UKR	Попередження: Якщо до виробу додаються дюбелі та гвинти, вони призначені виключно для використання на стінах з цільних й однорідних матеріалів, щоб не допустити перекидання. Перед свердлінням переконайтеся, що на місці свердління немає ліній газо-, водопостачання чи електропроводки. Для кріплення до інших стін необхідно використовувати спеціальні дюбелі. Запитайте продавця, які гвинти та/або дюбелі підходять для стіни з відповідною структурою. Виробник не несе відповідальності за неправильний монтаж та збитки, що виникли внаслідок цього. Перевіряйте та підтягуйте всі гвинти через регулярні проміжки часу.
LT	Įspėjimas: jei prie prekės pridėtos mūrvinės ir varžtai, jie skirti naudoti tik ant sienų, pagamintų iš tvirtų ir vienujų medžiagų, kad būtų galima išvengti apvirtilimo. Prieš gręždami įsitinkite, kad gręžiamoje vietoje nėra dujotiekio, vandentiekio ar elektros linijų. Tvirtinant prie kito tipo sienų reikia naudoti specialias mūrvines. Teiraukitės pardavėjo atitinkamai sienos konstrukcijai tinkamų varžtų ir (arba) mūrvinių. Gamintojas neprisiima atsakomybės dėl netinkamo montavimo ir dėl to atsiradusios žalos. Visus varžtus reguliariai tikrinkite ir priveržkite.
LV	Brīdinājums: Ja precei ir pievienoti dībeļi un skrūves, prece ir paredzēta izmantošanai tikai uz sienām, kas izgatavotas no cietiem un viendabīgiem materiāliem, lai novērstu apgāšanos. Pirms urbšanas pārlicinieties, ka urbšanas vietā nav gāzes, ūdens vai elektropārvades līniju. Lai piestiprinātu pie citām sienām, jāizmanto speciāli dībeļi. Jautājiet savam izplatītājam par skrūvēm un/vai dībeļiem, kas ir piemēroti attiecīgajai sienas konstrukcijai. Ražotājs neuzņemas atbildību par nepareizu montāžu un no tās sekojošajiem bojājumiem. Lūdzu, regulāri pārbaudiet un pievelciet visas skrūves.
EE	Hoiatus! Kui tootele on kaasa pandud tüüblid ja kruvid, on need mõeldud kasutamiseks üksnes massiivsest ja ühtsest materjalist seintel, vältimaks ümberkukkumist. Veenduge enne puurimist, et puurimiskohas ei oleks gaasi- või veetorusid ega elektrijuhtmeid. Seintele kinnitamiseks tuleb kasutada spetsiaalseid tüüpleid. Uurige kaubandusvõrgust, millised kruvid ja/või tüüblid konkreetselt seinale sobivad. Tootja ei võta endale mittenõuetekohasest paigaldamisest tingitud kahjude eest mingit vastutust. Kontrollige ja järelpingutage kõiki kruvisid regulaarselt.



**LE TRI
+ FACILE**



FR

**Donnez ou recyclez
vos meubles.**



Association



Magasin



Déchèterie

<https://quefairedemesdechets.fr>