

# Einbauanleitung

## Installation Instruction

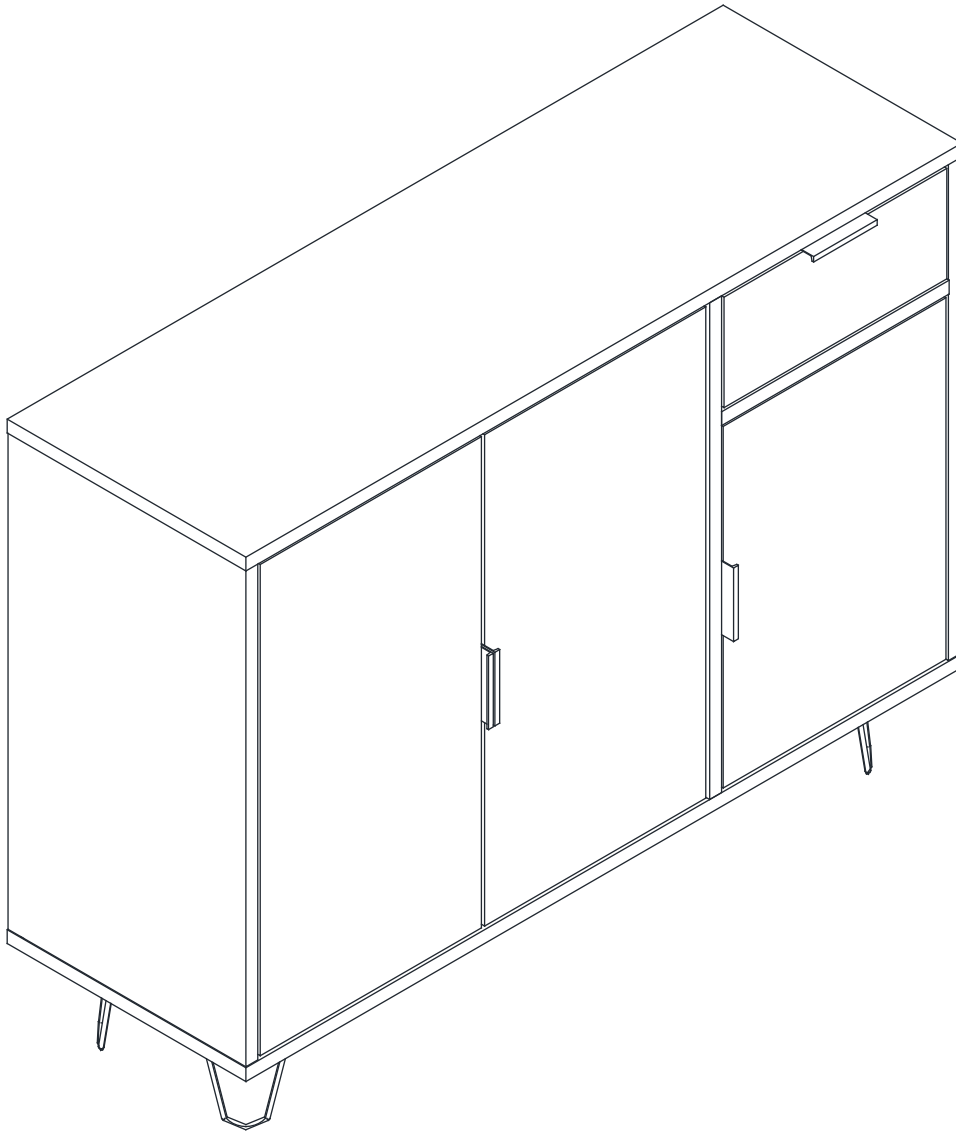

# Montage

# Assembling

Geschätzte Zeit für die Montage

Estimated time for assembly



**30 : 00**

Was Sie brauchen

What you need

- Verwenden Sie den Verpackungskarton als Arbeitsfläche, um Produktschäden während der Montage zu vermeiden
- Kreuzschlitzschraubendreher
- Use the packaging carton as a working surface to prevent product damage during assembly
- Phillips head screwdriver

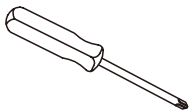

Gewichtsbeschränkung

Weight Limitation



**20** | **5** | **10**  
kgs Tischplatte    kgs pro Schublade    kgs pro Regal  
kgs table top    kgs per drawer    kgs per shelf



2 PERSONEN

2 PERSONS

## Was ist enthalten

## What's included

Nr.	Beschreibung	Menge
Code	Description	Qty
A	Cam Bolt M6X35MM	12
B	Cam Lock 15X10MM	12
C	Screw M4X35MM	12
D	Wooden Dowel M6X30MM	14
E	Screw M4X14MM	22
F	Screw M4X14MM	44
G	Screw M3X14MM	8
H	Screw M3X12MM	8
I	Plastic corner support	4
J	Handle	4
K	Slide sets	1
L	Magnetic Door Catcher	2
M	Metal Support	4
N	Hinge	6
O	Nylon Strap	2
P	Anchor M6×30mm	2

# Die Hardware

## The Hardwares

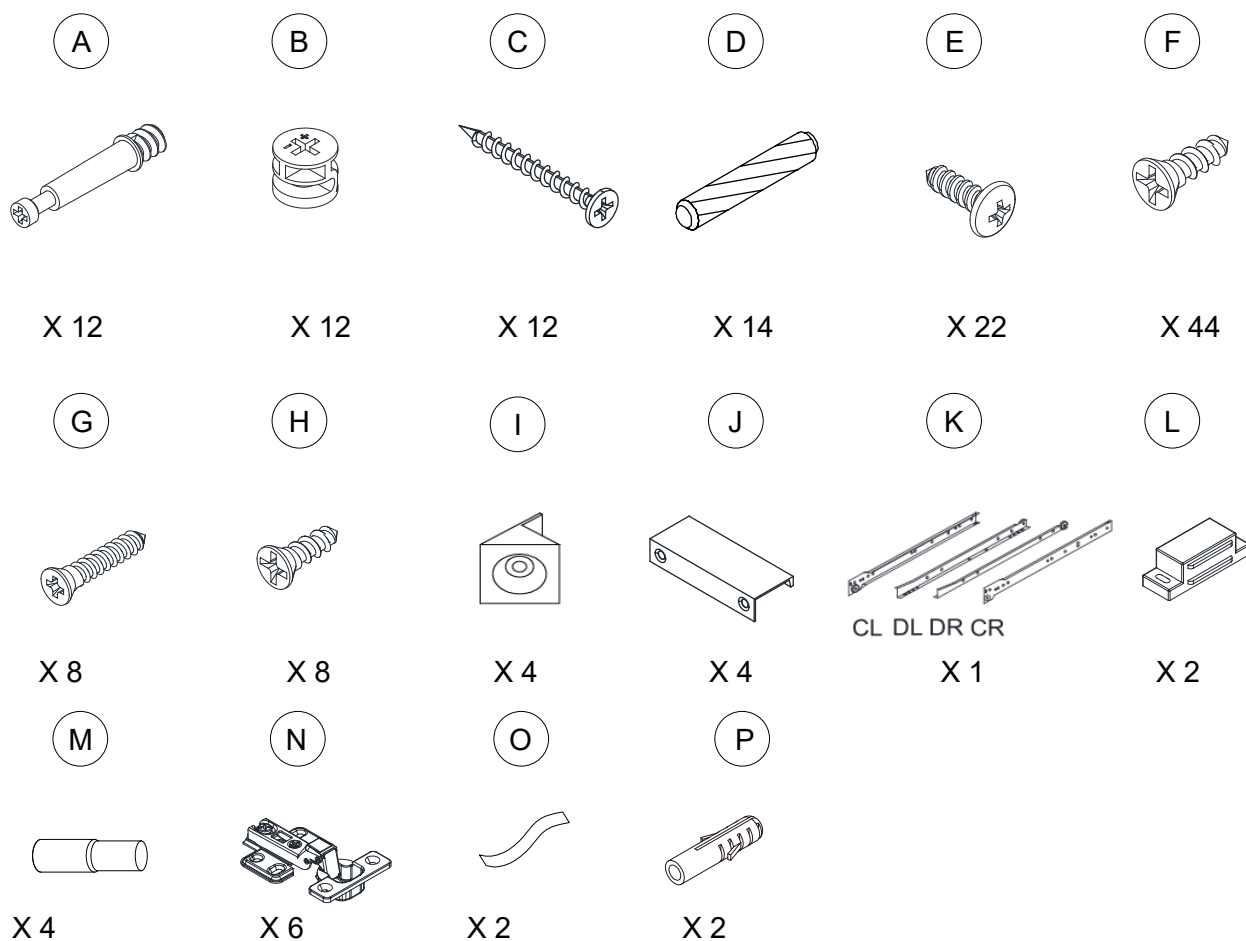

### WICHTIG:

1. Ziehen Sie die Bolzen/Schrauben nicht vollständig an, bis alle Bolzen/Schrauben ausgerichtet und in die Löcher eingesetzt sind.
2. Schrauben und Bolzen nicht zu fest anziehen, um ein Ablösen zu vermeiden.
3. Bitte verwenden Sie Handwerkzeuge, um dieses Produkt zusammenzubauen. Verwenden Sie keine Elektrowerkzeuge.

### IMPORTANT:

1. Do not tighten bolts / screws completely until all bolts / screws are lined up and inserted into holes.
2. Do not over tighten screws and bolts to avoid stripping.
3. Please use hand tools to assemble this product. Do not use power tools.



2 PERSONEN

2 PERSONS

# Enthaltenes Zubehör

## Included Accessories

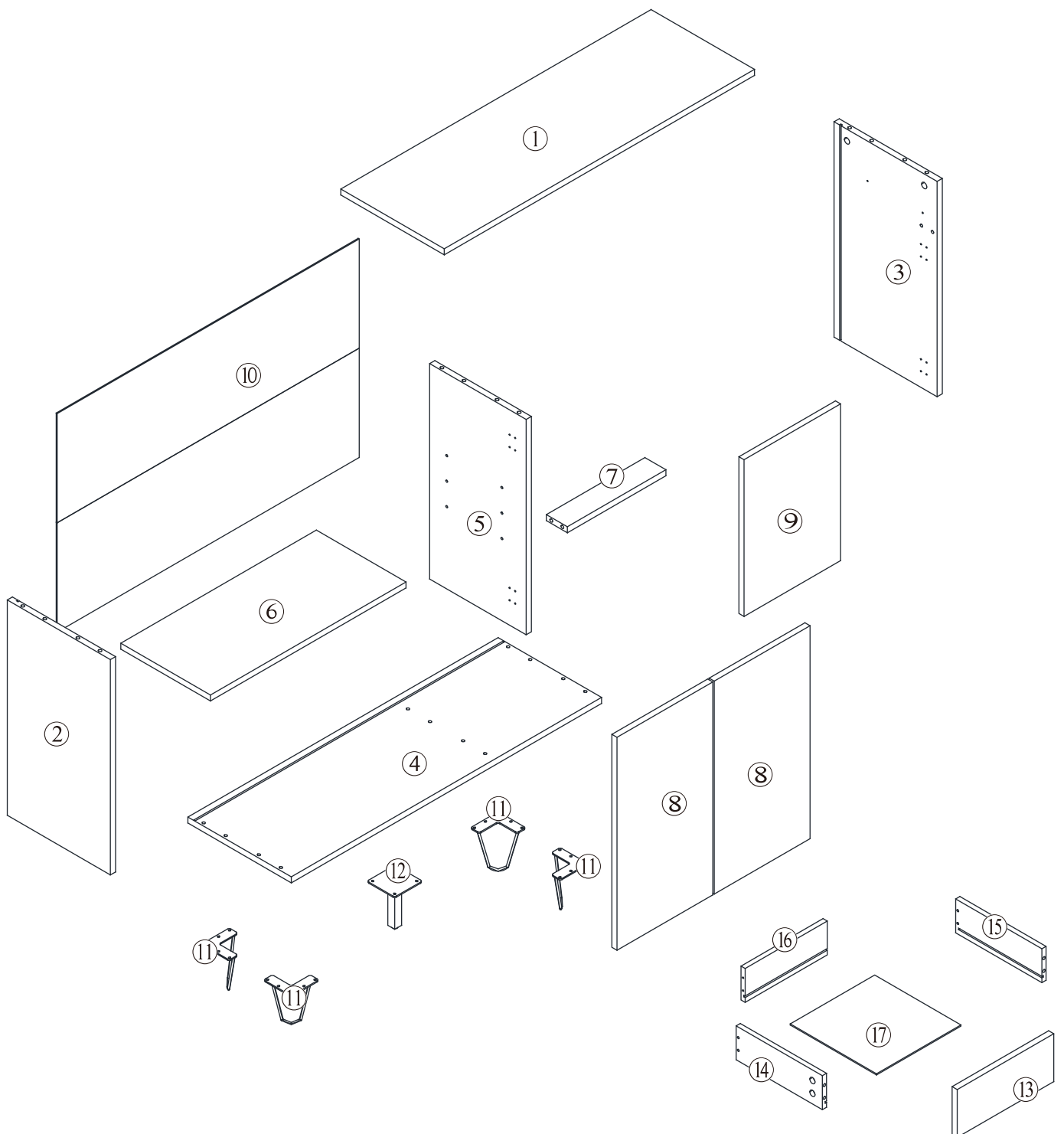

# Schritt 1

## Step 1

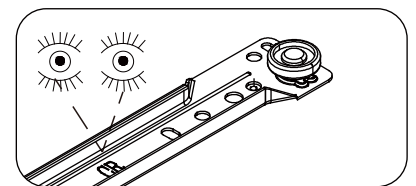
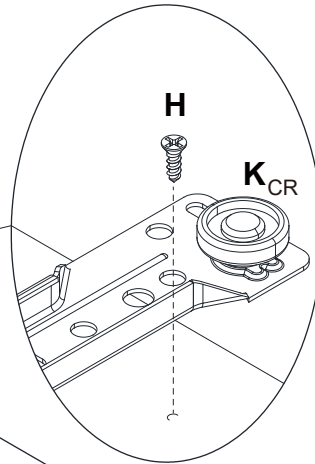
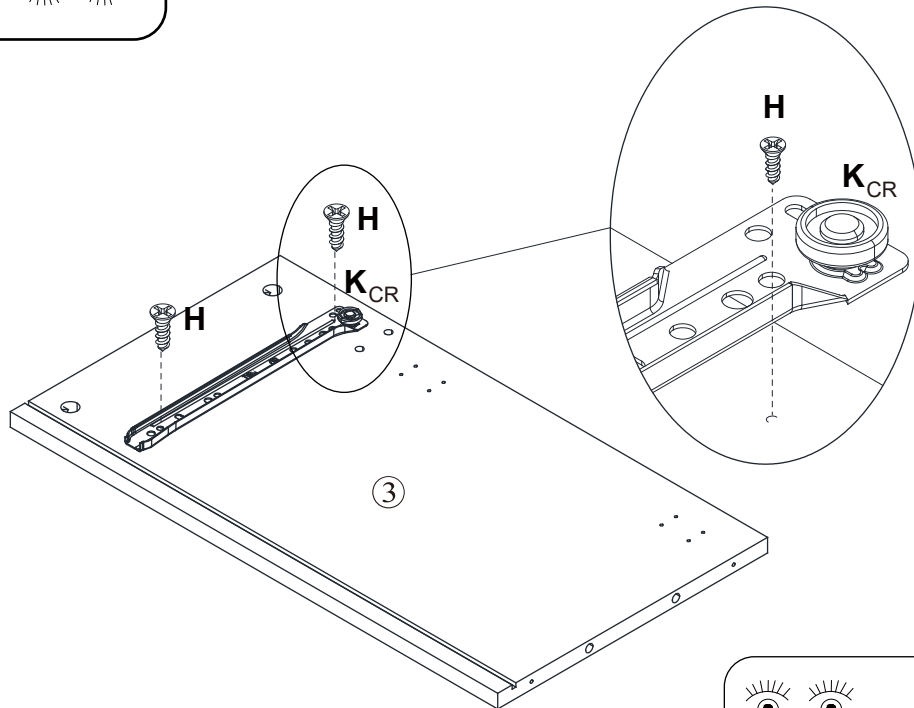
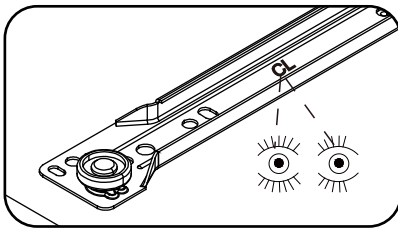
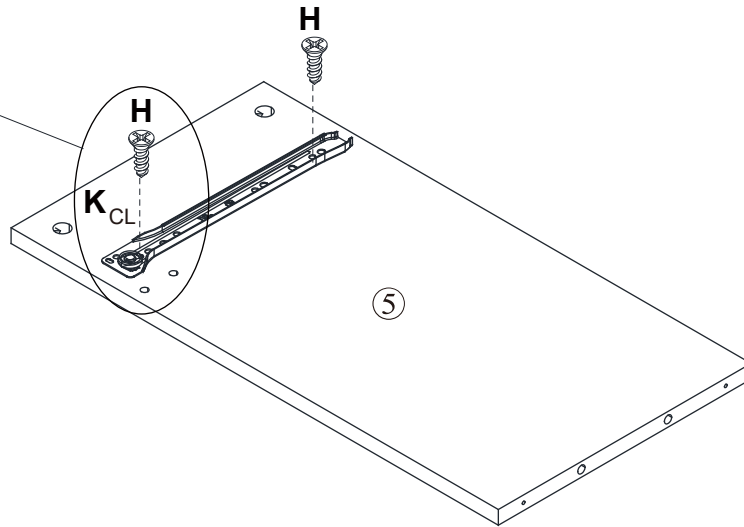
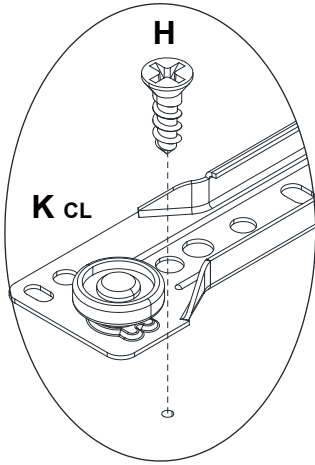
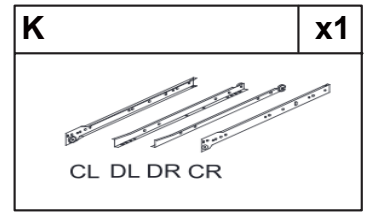
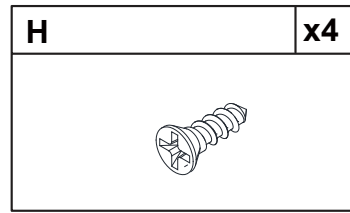

# Schritt 2

## Step 2

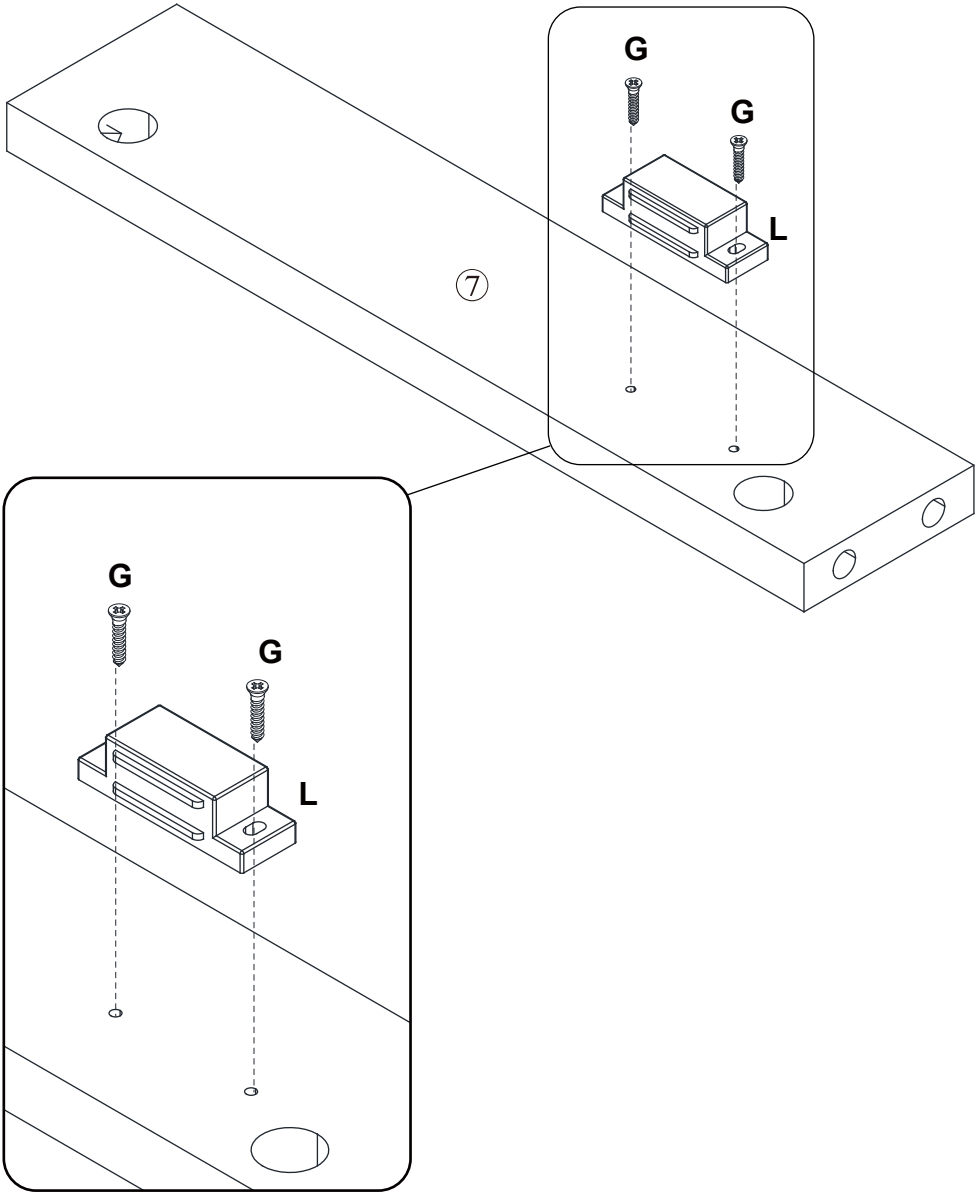
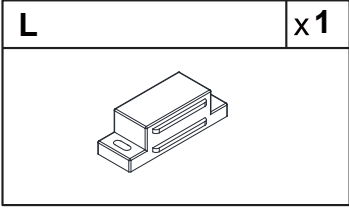
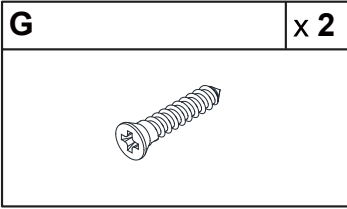

# Schritt 3

## Step 3

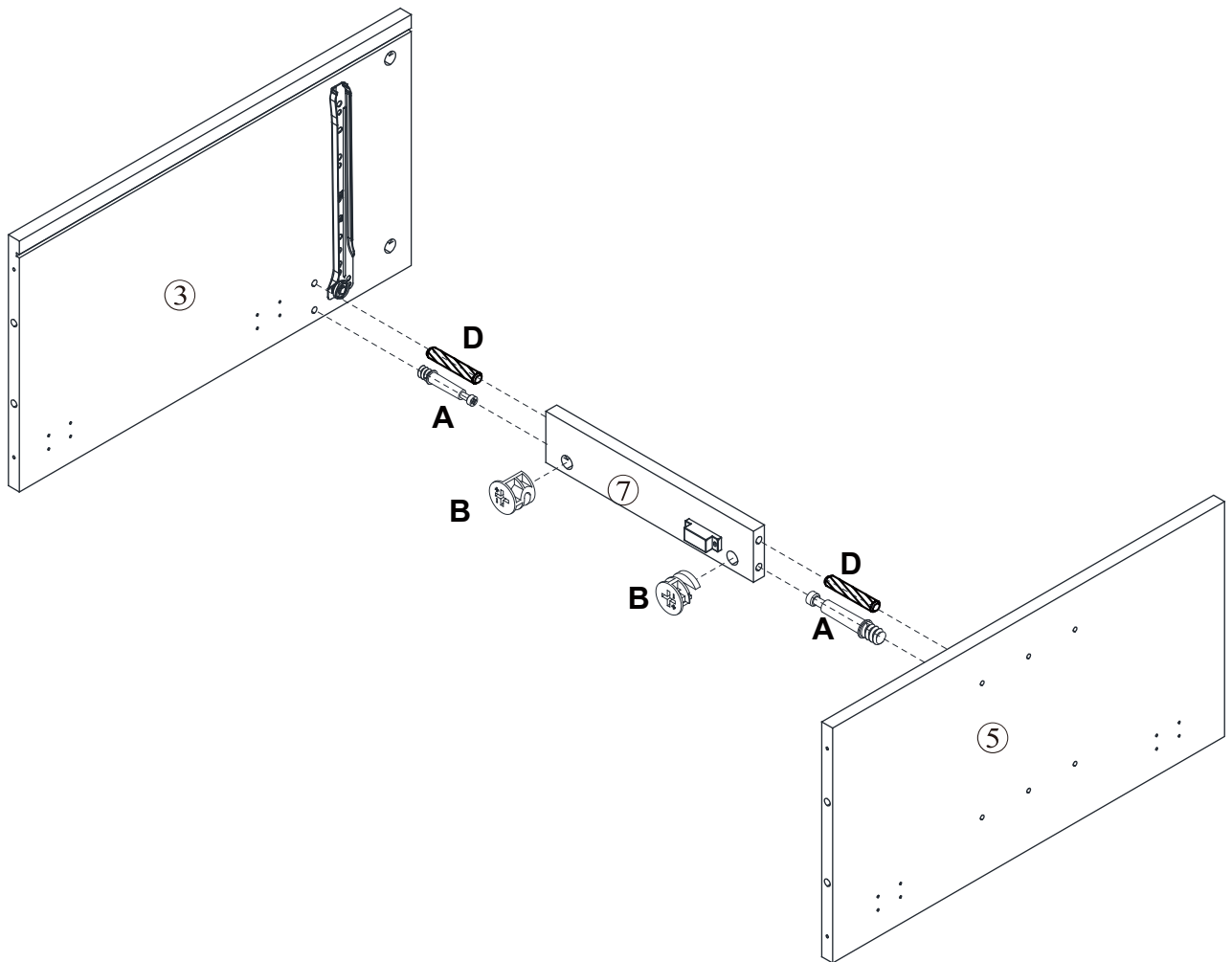
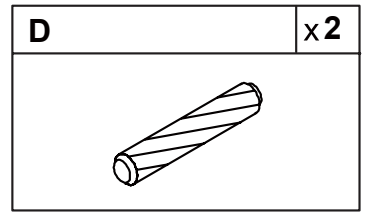
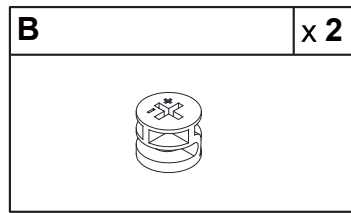
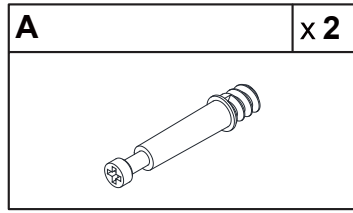

# Schritt 4

## Step 4

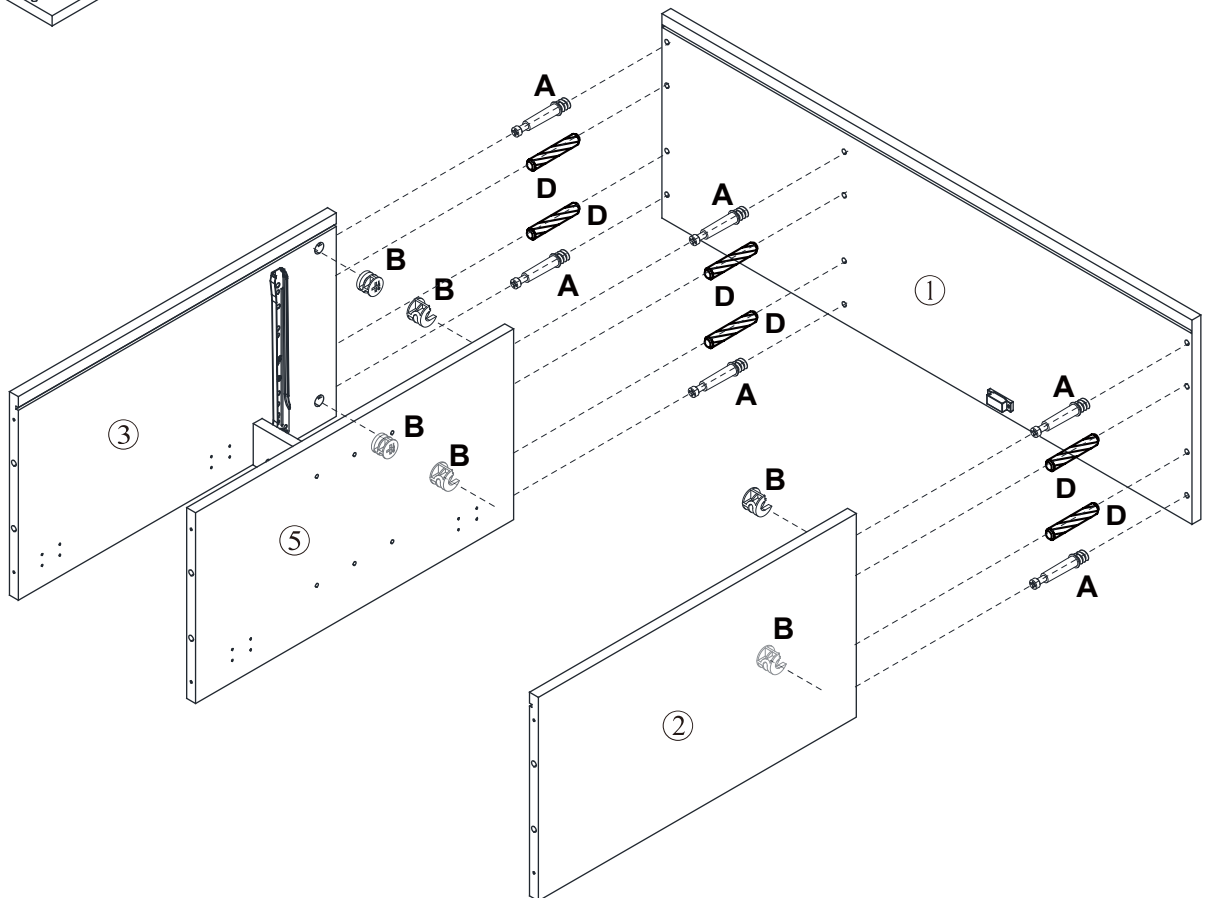
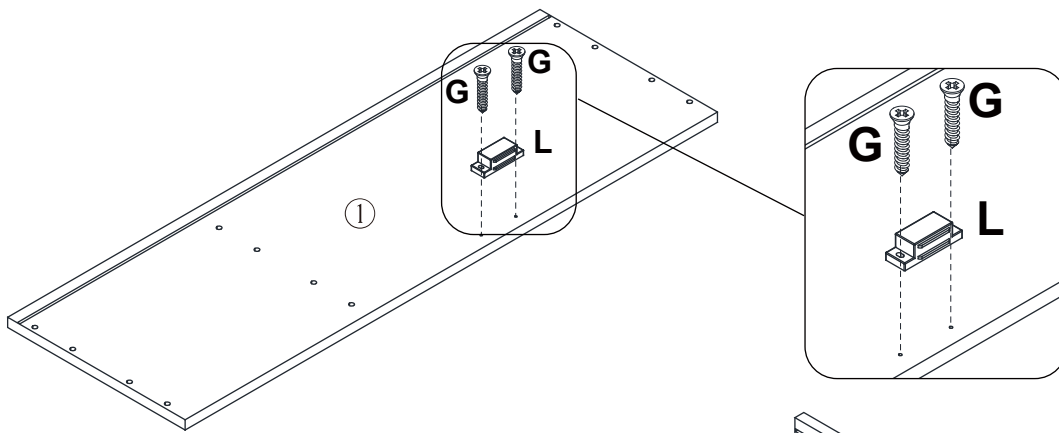
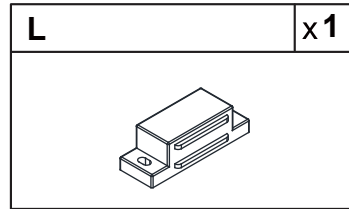
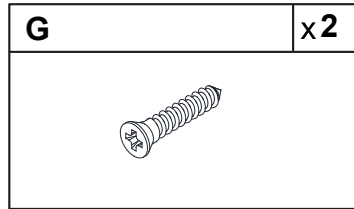
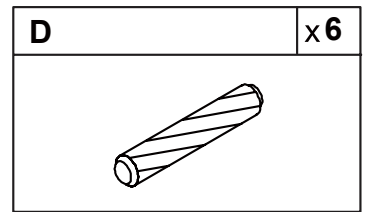
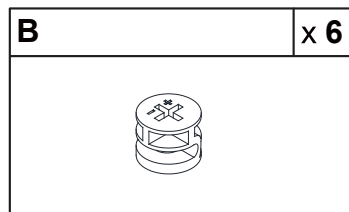
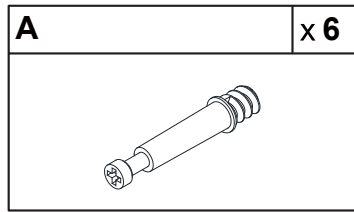



# Schritt 5

## Step 5

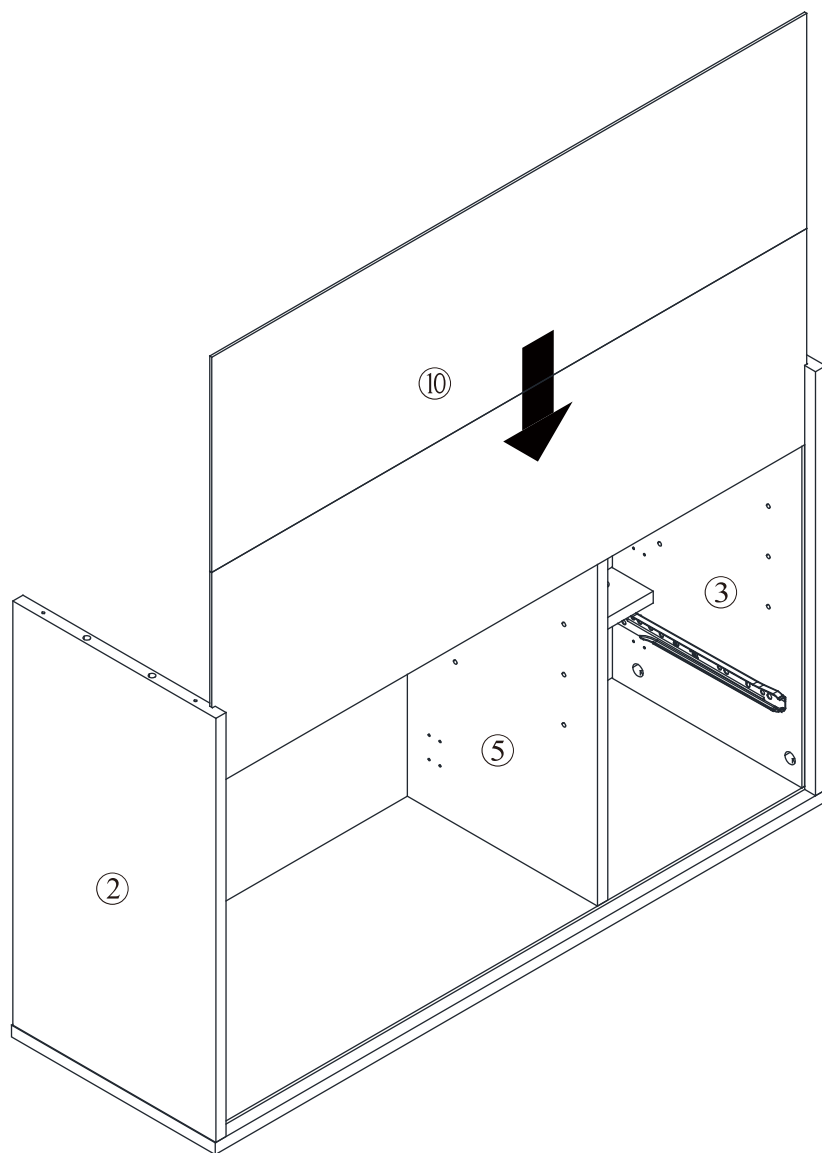

# Schritt 6

## Step 6

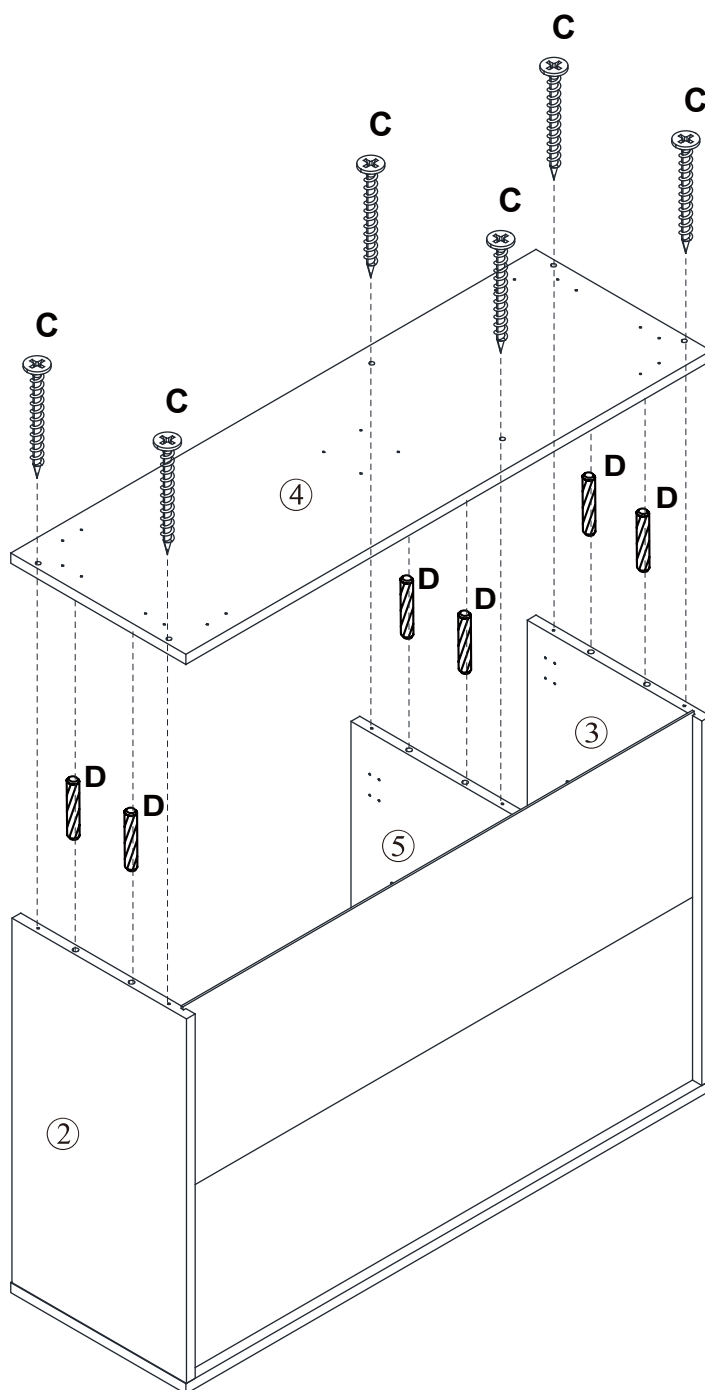
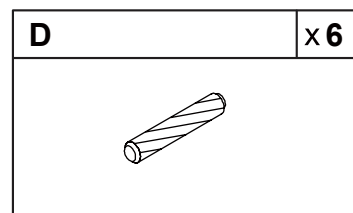
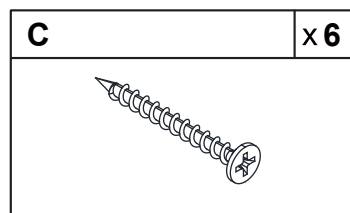

# Schritt 7

## Step 7

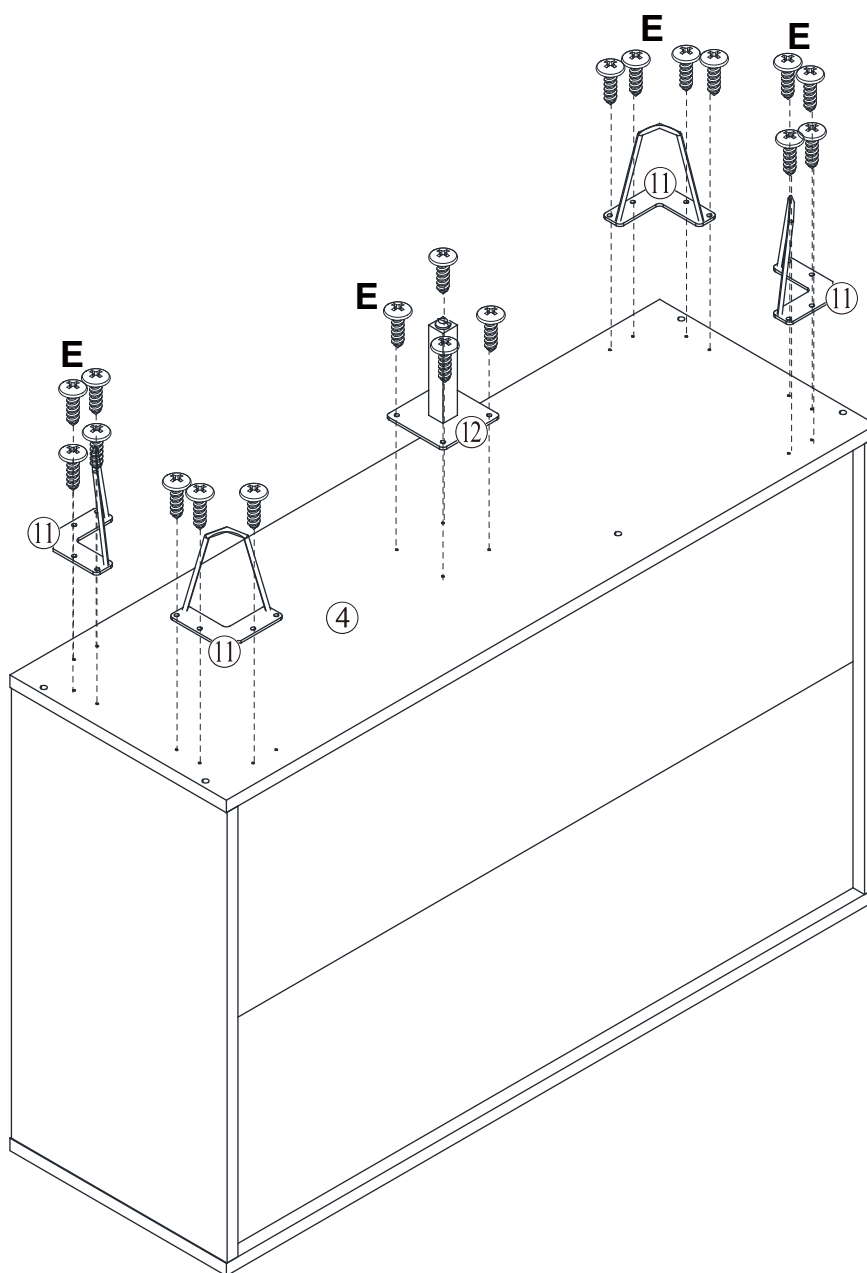
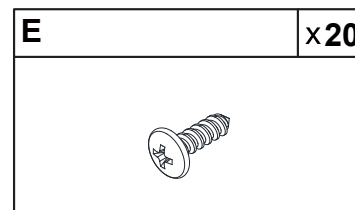

# Schritt 8

## Step 8

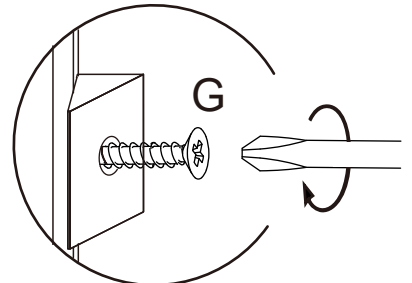
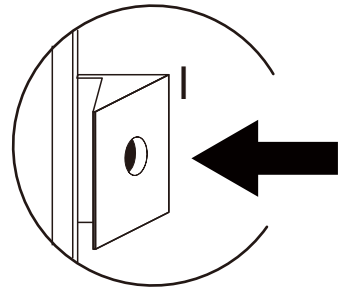
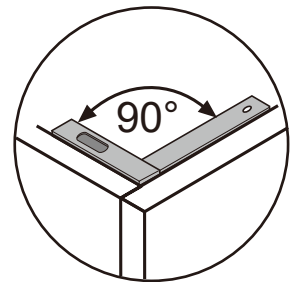
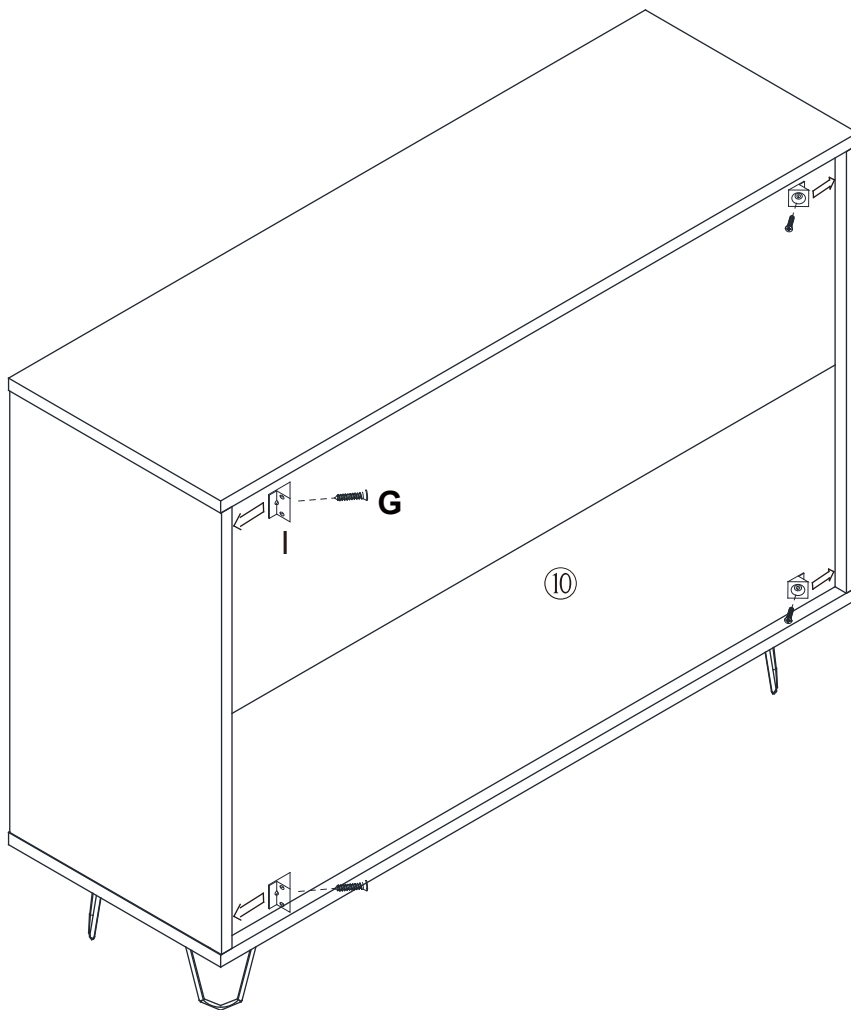
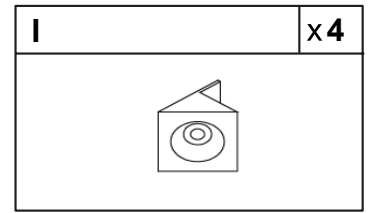
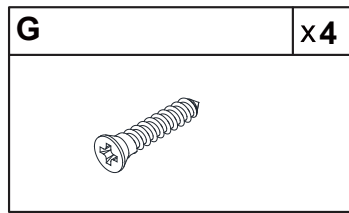

# Schritt 9

## Step 9

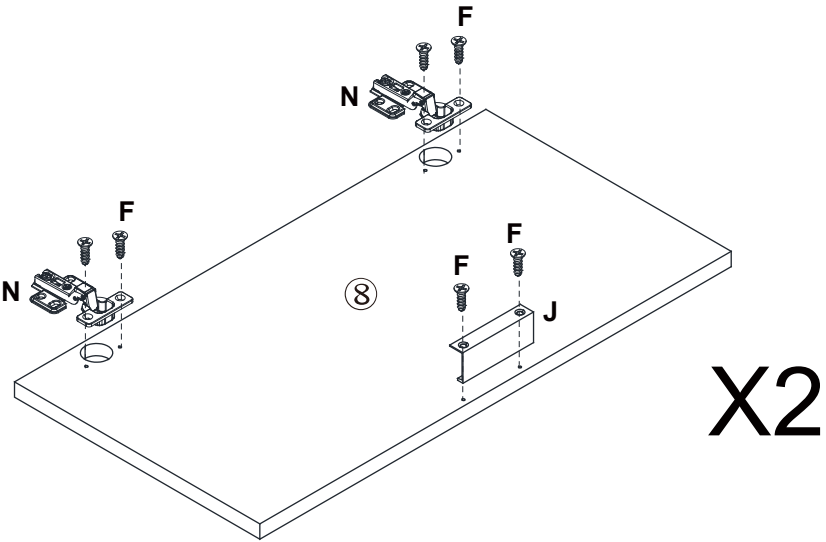
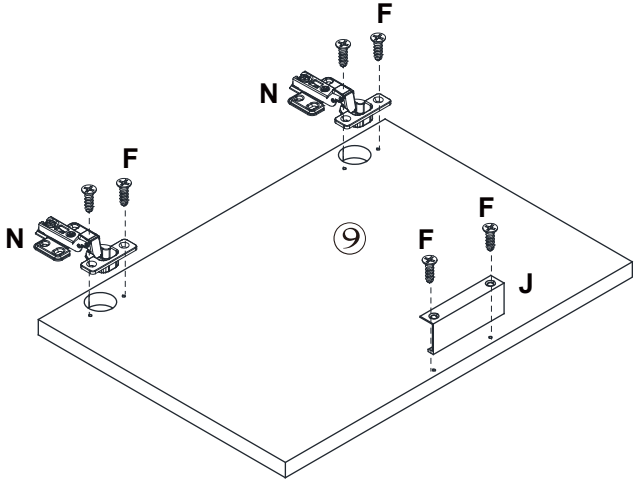
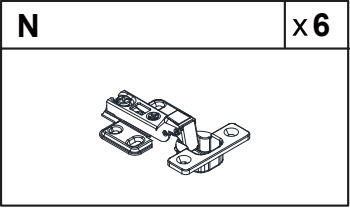
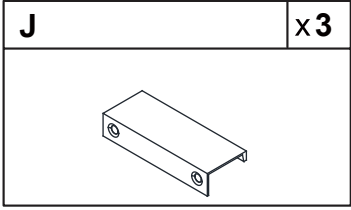
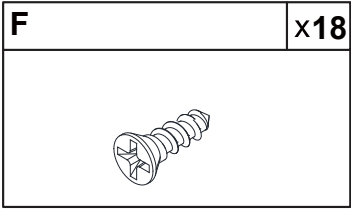

# Schritt 10

## Step 10

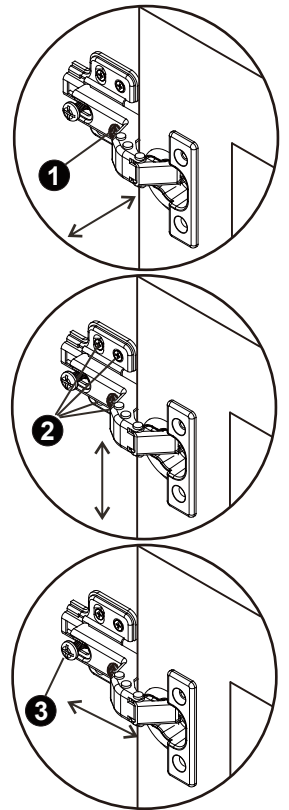
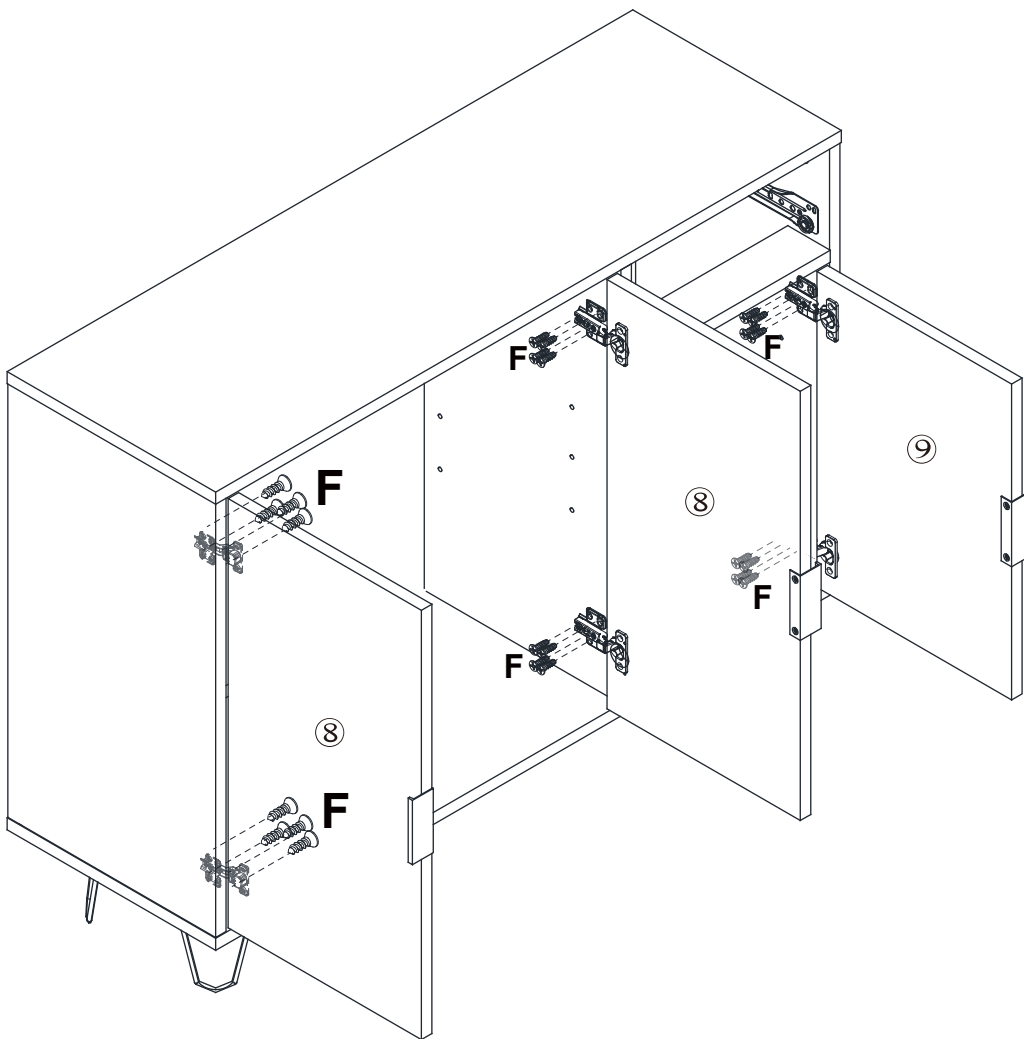
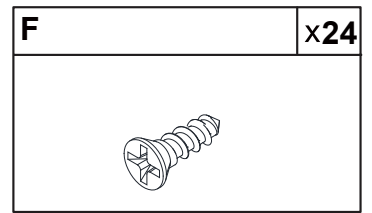

# Schritt 11

## Step 11

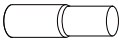
<b>M</b>	<b>x4</b>
	

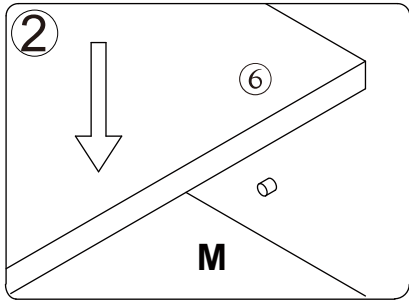
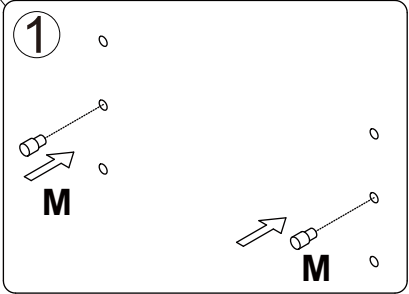
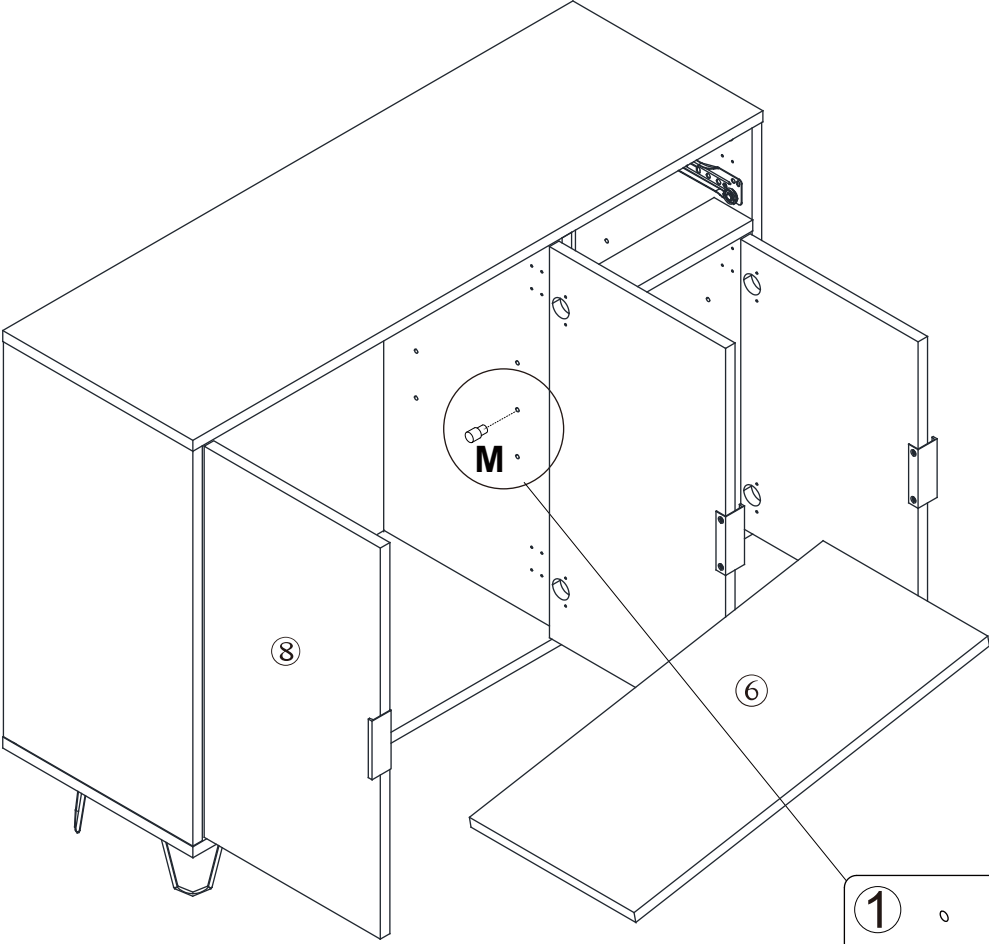

# Schritt 12

## Step 12

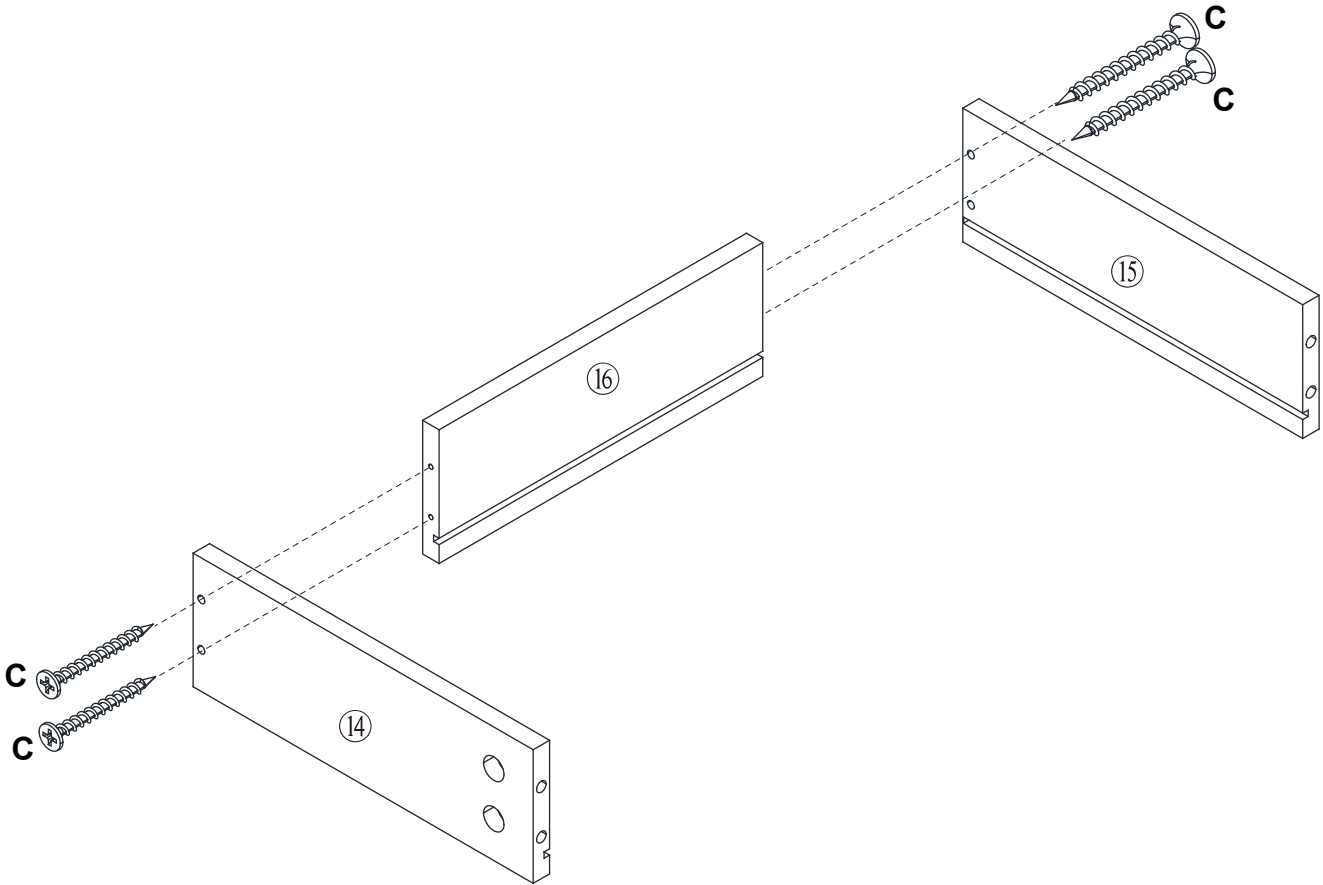
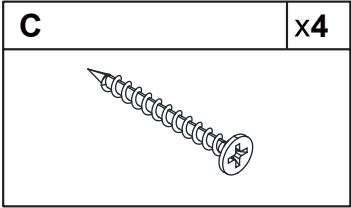



# Schritt 13

## Step 13

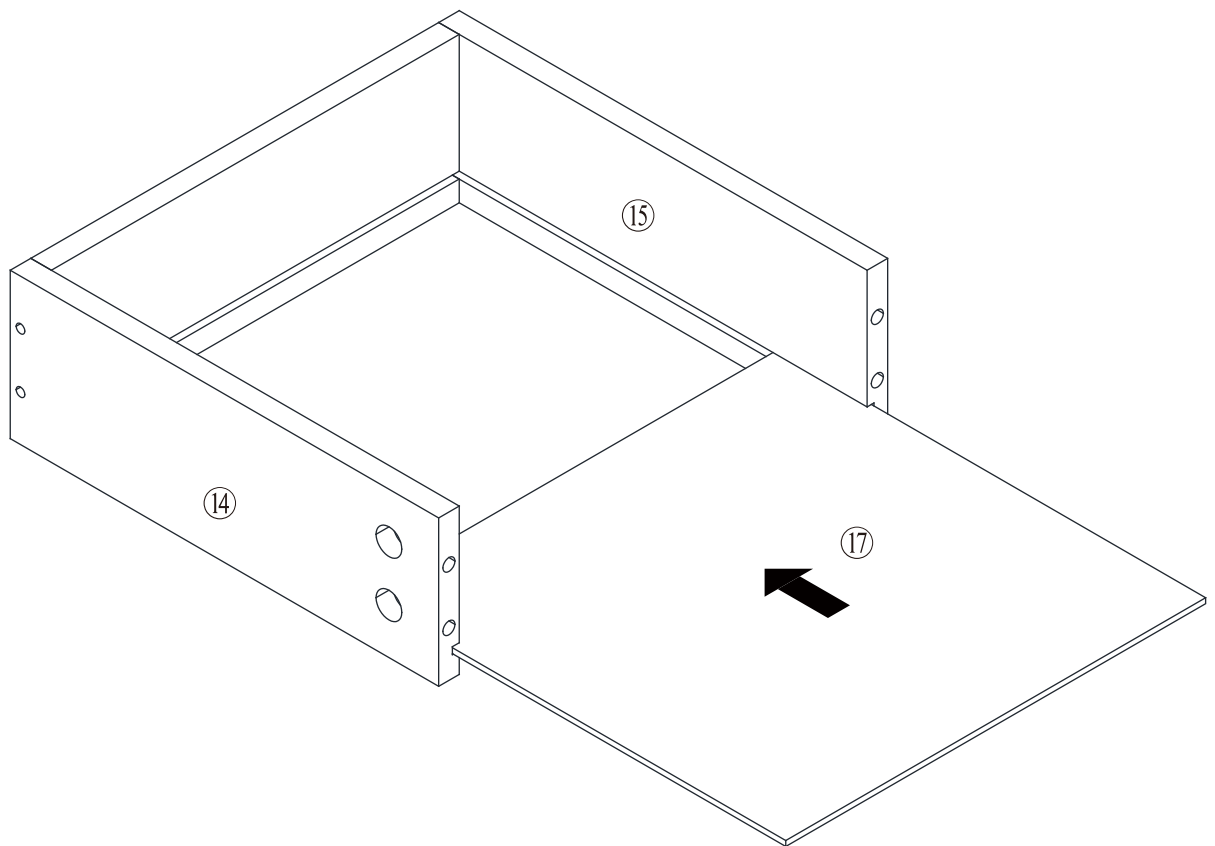

# Schritt 14

## Step 14

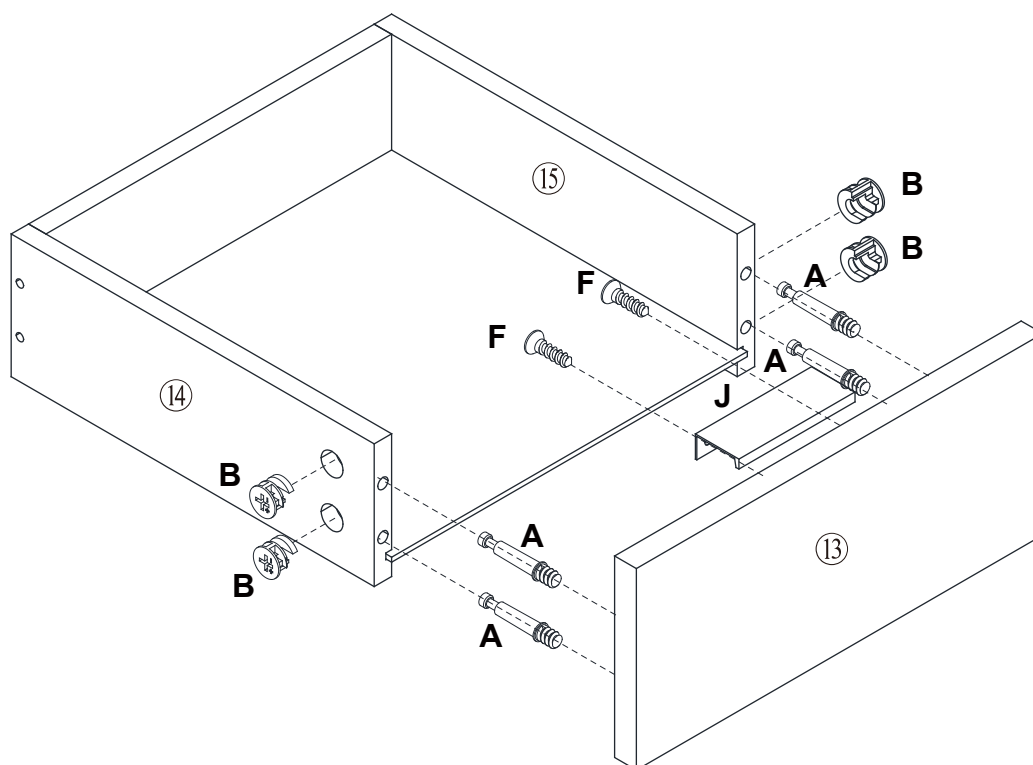
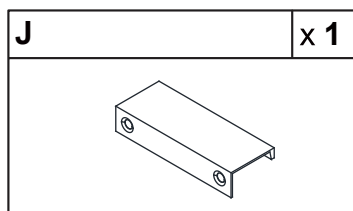
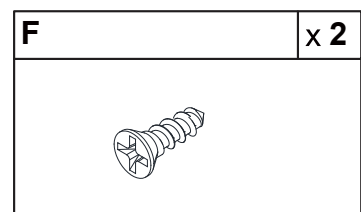
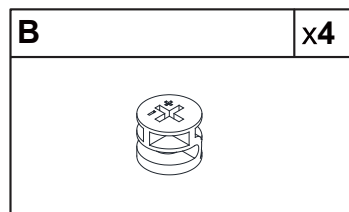
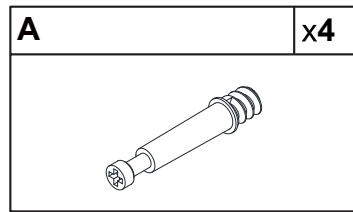

# Schritt 15

## Step 15

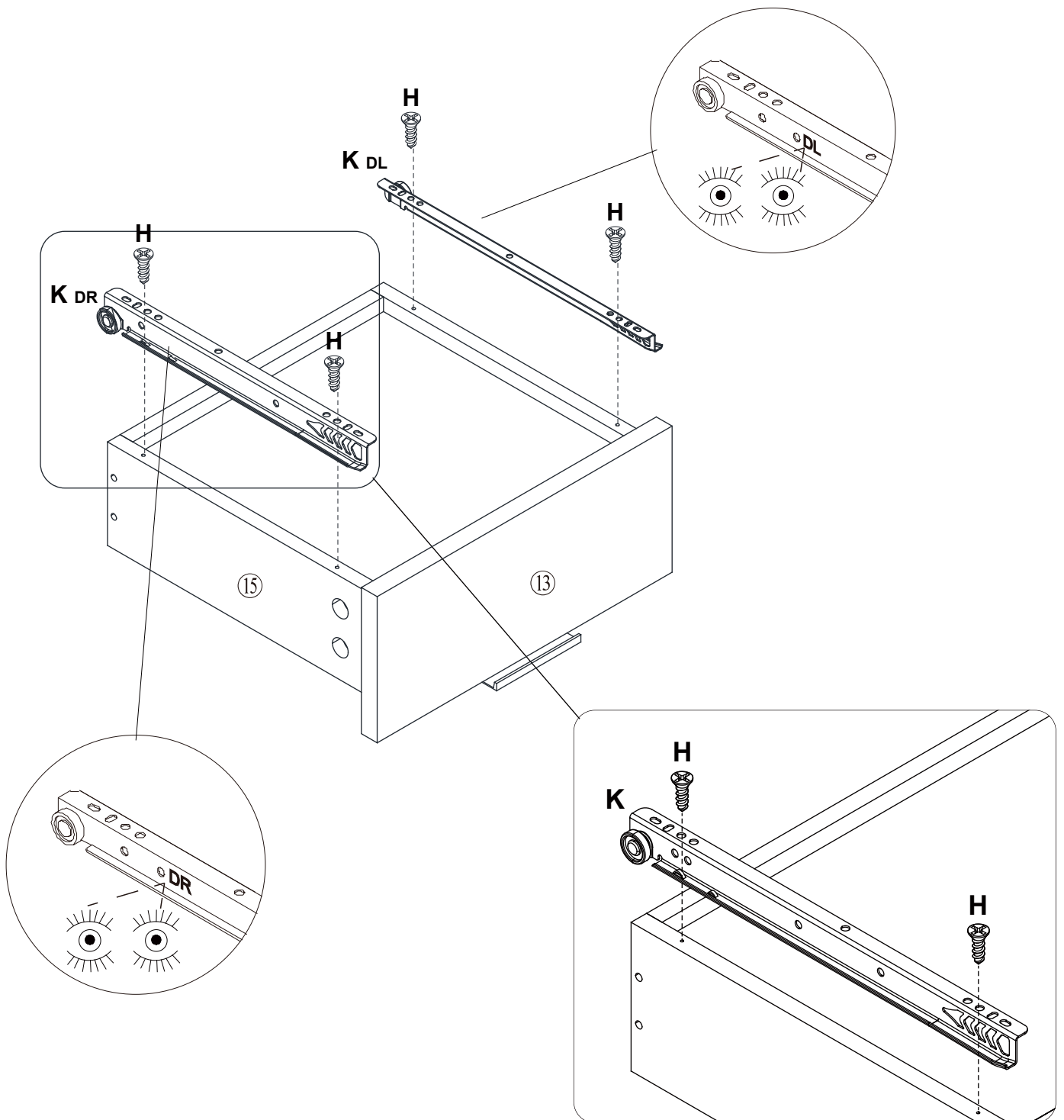
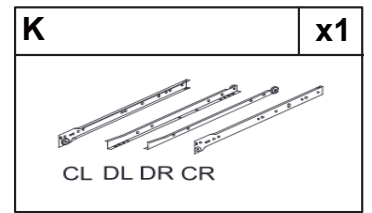
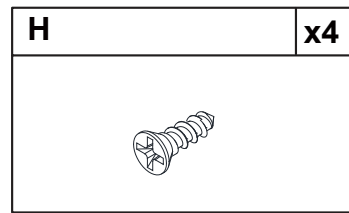

# Schritt 16

## Step 16

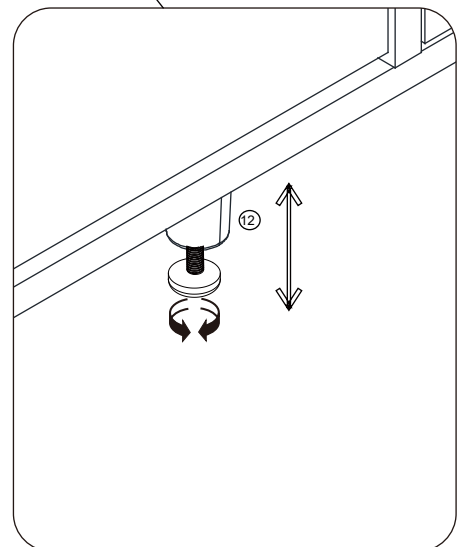
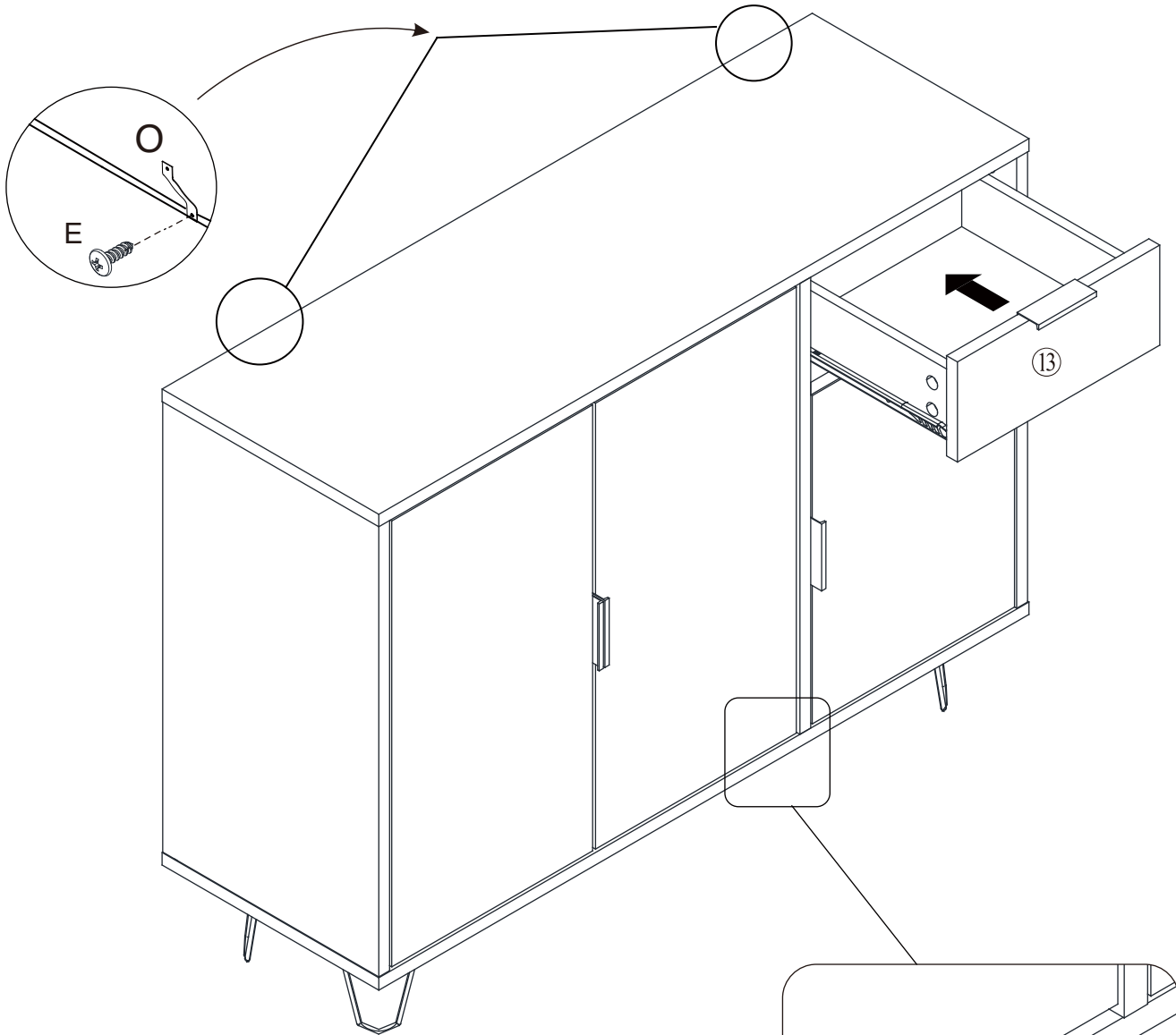
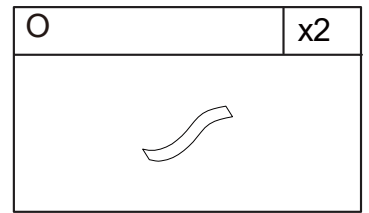
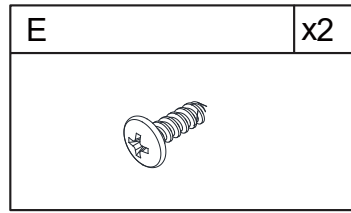

# Schritt 17

## Step 17

