

ASSEMBLY INSTRUCTION

ROPE SOFA SETS

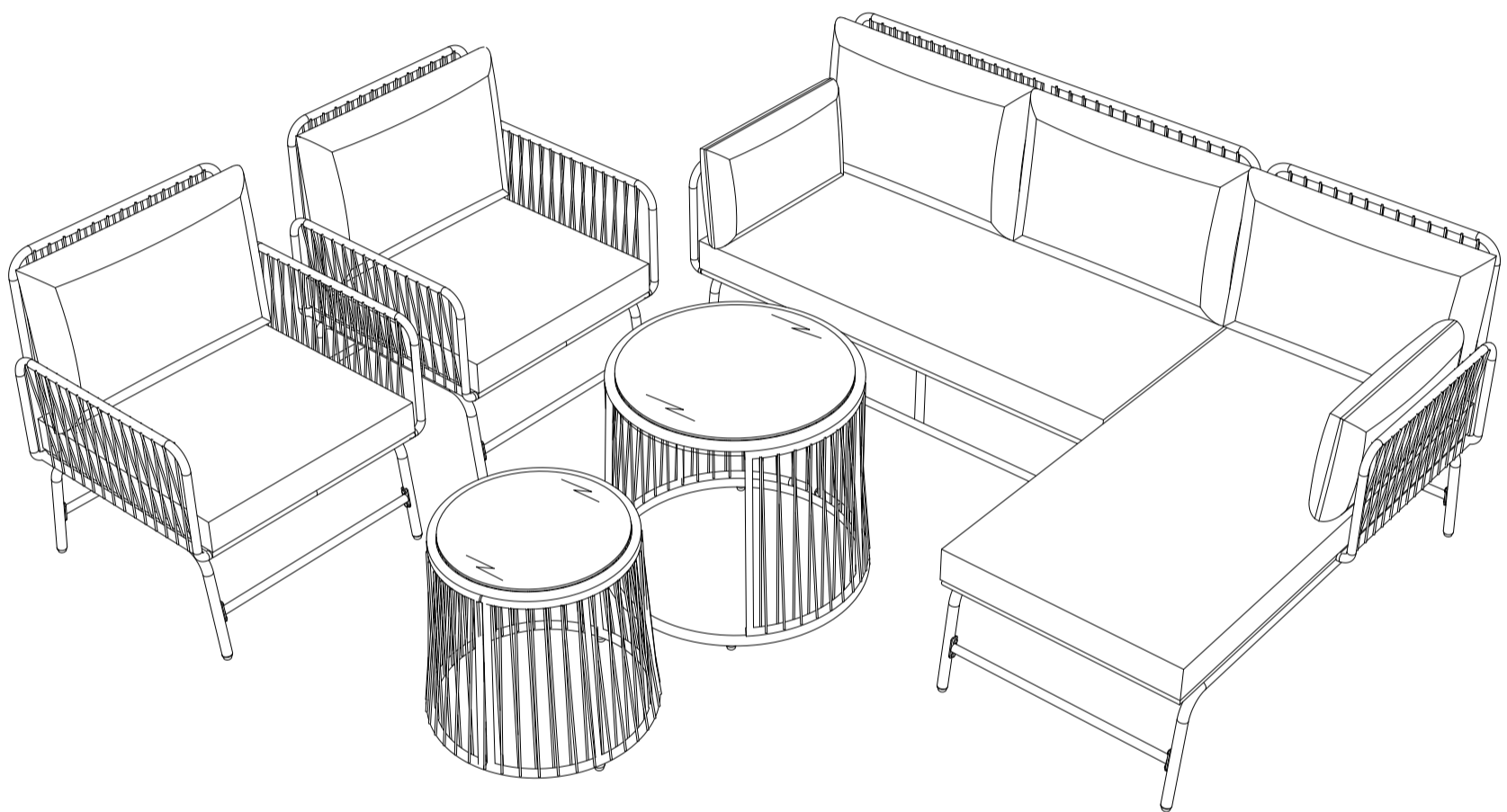

WF316572; WF316573 WF316574

Before installation, insert the screws into the holes and tighten them, but do not tighten them to 100%, 70% to 80% is sufficient. Finally, after all screws are installed, tighten all screws to 100%. If you encounter these issues, such as if the holes cannot be aligned or some parts cannot be installed, please check if the screws are used correctly and adjust the tightness of the screws.

x1

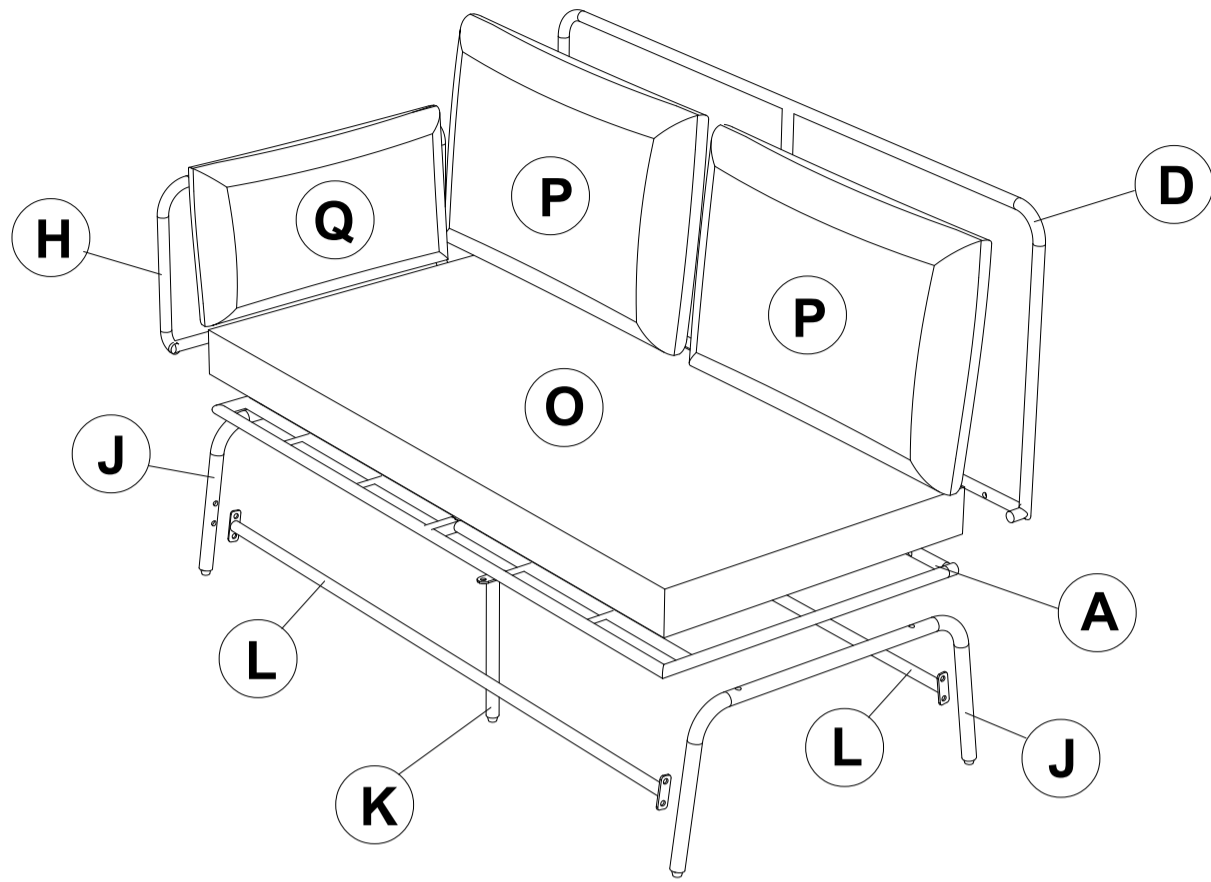

x1

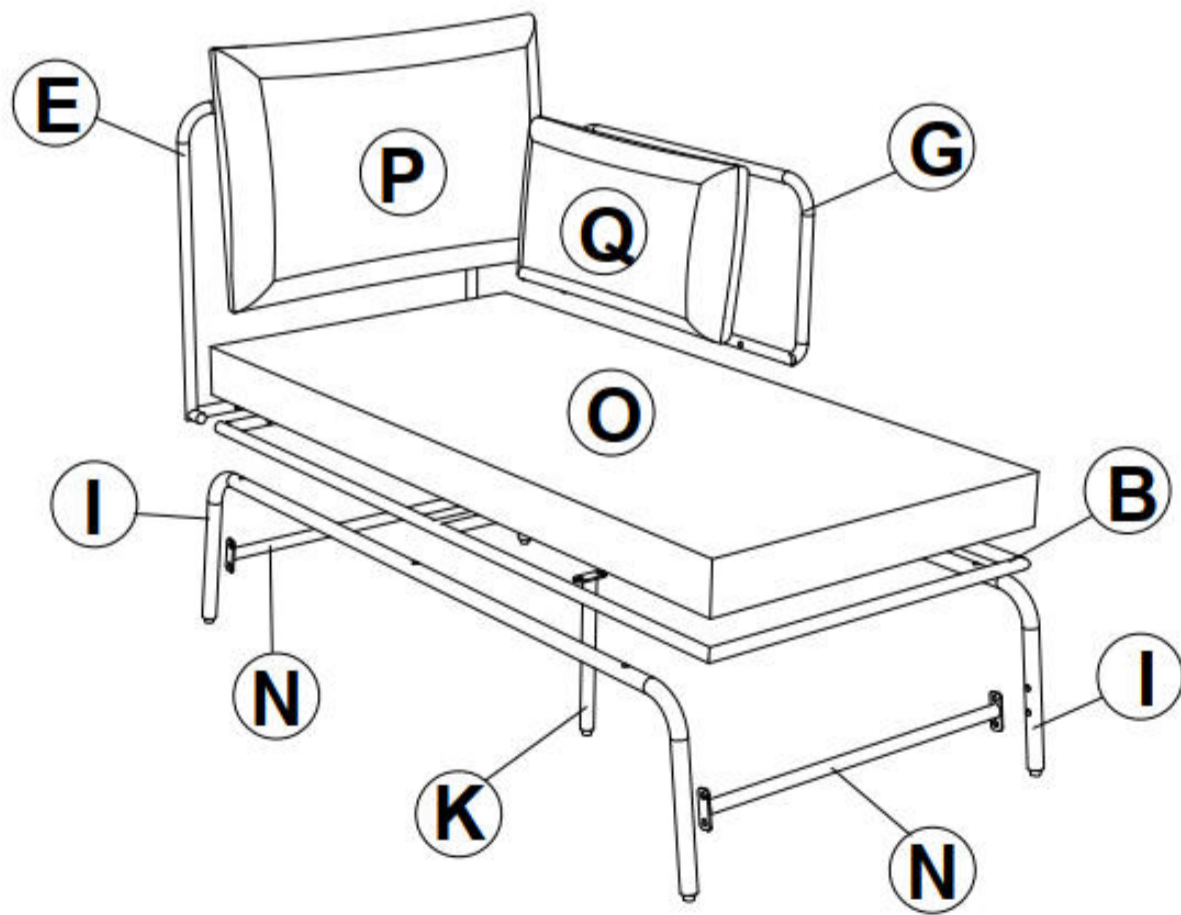

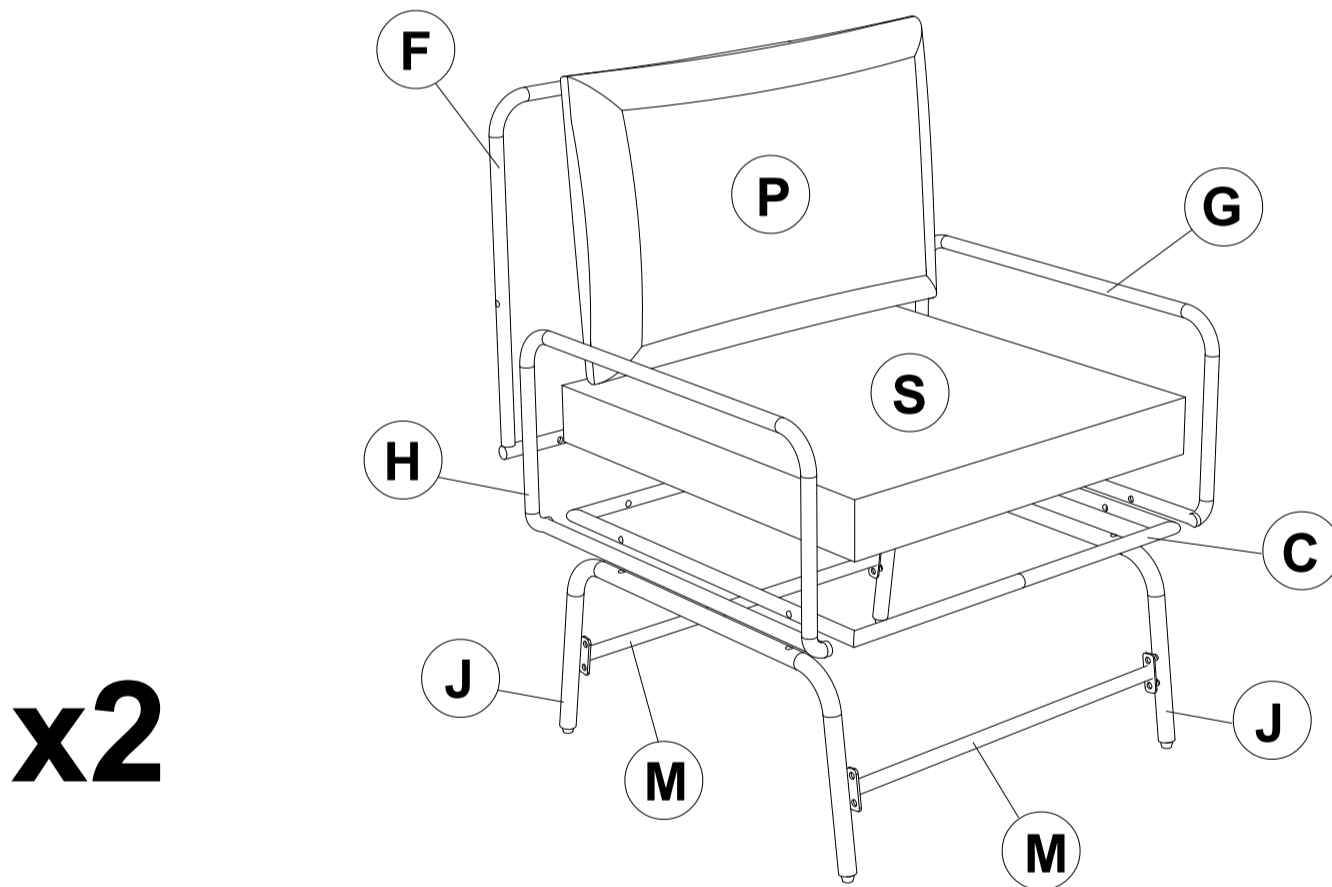
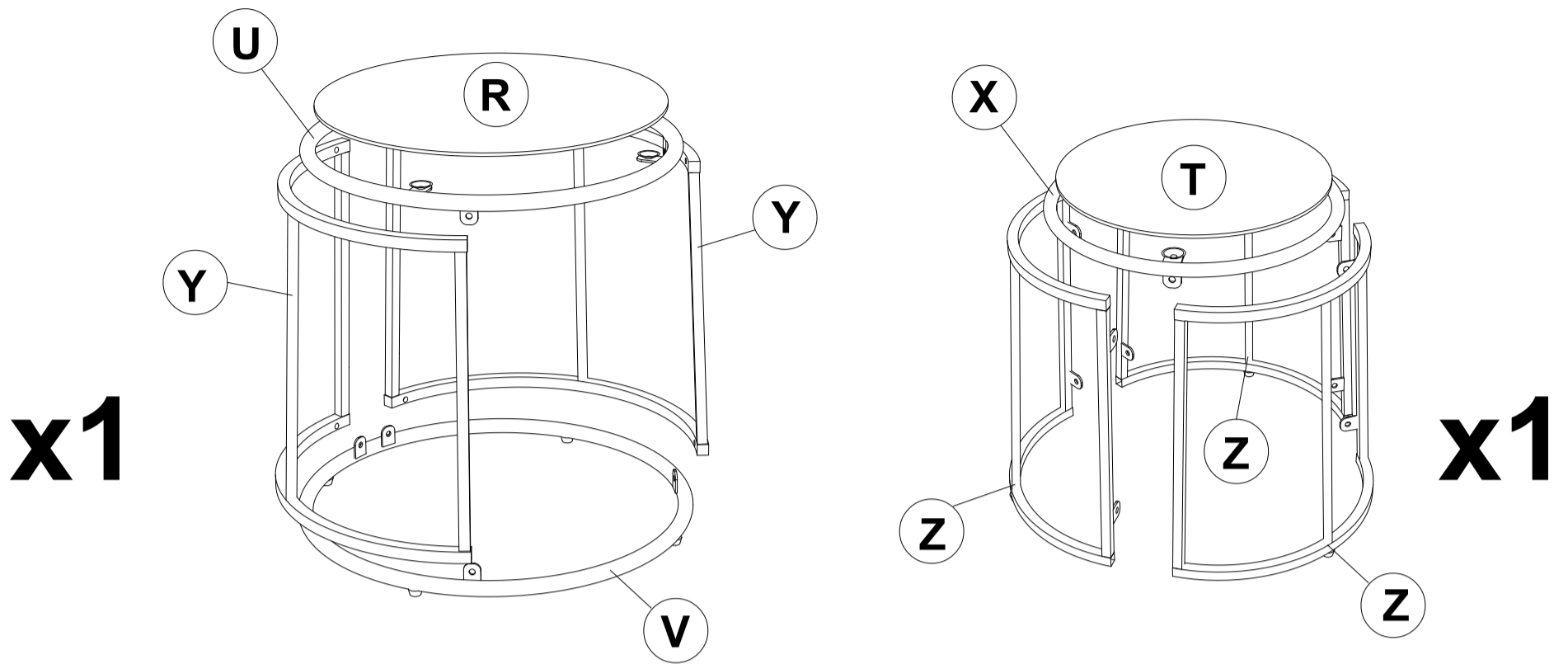



Notice:

1. 50% Tighten before fixing all screws, Allen wrench is recommended instead of an electric drill.
2. Place the item on a flat ground to adjust and make sure it remains stable.
3. Tighten up all screws with tools gradually.
4. If the screws are not aligned with holes during assembly, please loosen all the other screws to 50% and continue the assembly process.
5. If the item is not stable, please loosen all the screws, adjust it on a flat ground and tighten up all screws again.
6. Note : If one or some screws are fully tightened during assembly, chances are the others will not be aligned with holes. In addition, all the holes are designed to be relatively larger to provide more space for the adjustment of the screws.

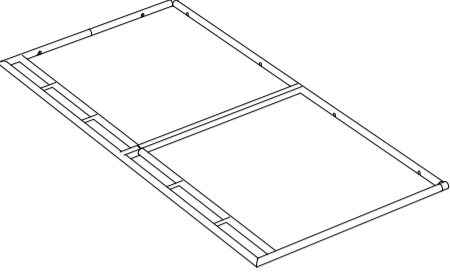
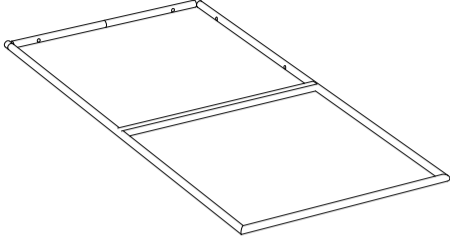
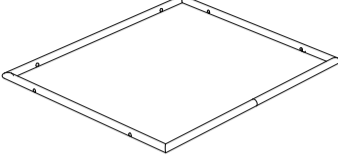
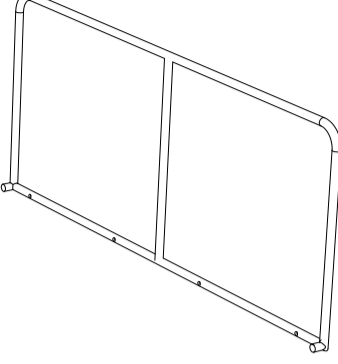
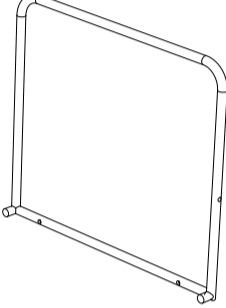
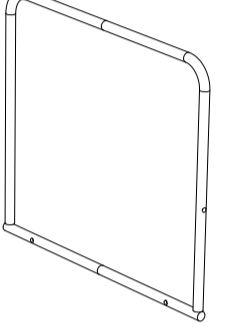
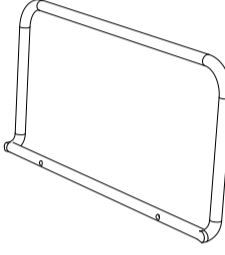
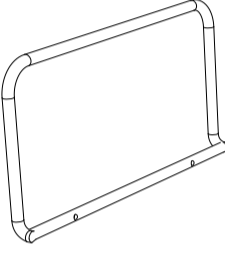
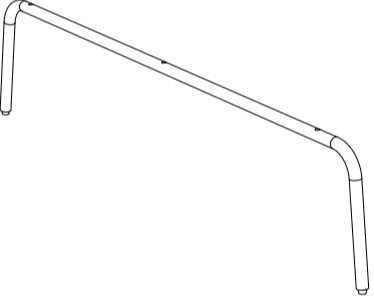
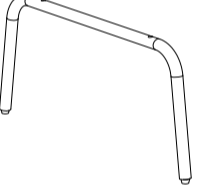
Part List:

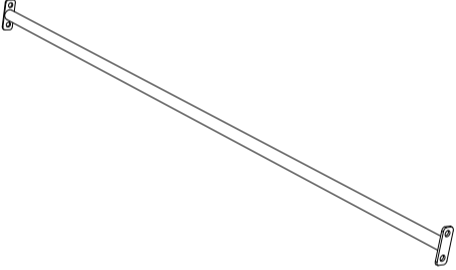
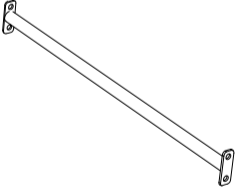
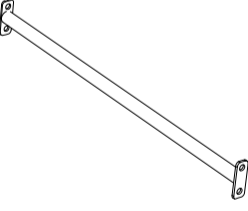
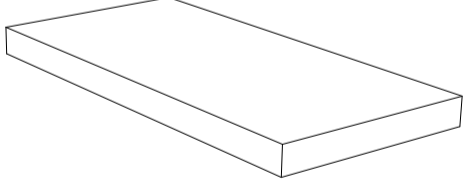
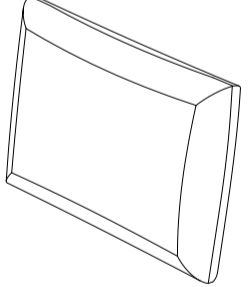
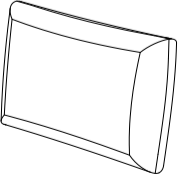
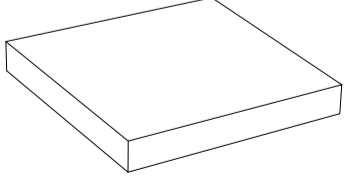
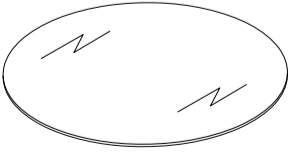
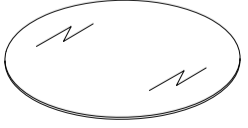
<p>A</p>  <p>Seat Bench 1 (1 pc)</p>	<p>B</p>  <p>Seat Bench 2 (1 pc)</p>	<p>C</p>  <p>Seat Chair (2 pcs)</p>	<p>D</p>  <p>Long Back Bench (1 pc)</p>
<p>E</p>  <p>Short Back Bench (1 pc)</p>	<p>F</p>  <p>Back Chair (2 pcs)</p>	<p>G</p>  <p>Left Arm (3 pcs)</p>	<p>H</p>  <p>Right Arm (3 pcs)</p>
<p>I</p>  <p>Long Leg (2 pcs)</p>	<p>J</p>  <p>Short Leg (6 pcs)</p>	<p>K</p>  <p>Support Leg (2 pcs)</p>	<p>L</p>  <p>Long Connection (2 pcs)</p>
<p>N</p>  <p>Short Connection 1 (2 pcs)</p>	<p>M</p>  <p>Short Connection 2 (4 pcs)</p>	<p>O</p>  <p>Seat Bench Cushion (2 pcs)</p>	<p>P</p>  <p>Back Cushion (5 pcs)</p>
<p>Q</p>  <p>Arm Cushion (2 pcs)</p>	<p>S</p>  <p>Seat Chair Cushion (2 pcs)</p>	<p>R</p>  <p>Big Glass Top (1 pc)</p>	<p>T</p>  <p>Small Glass Top (1 pc)</p>

Part List:

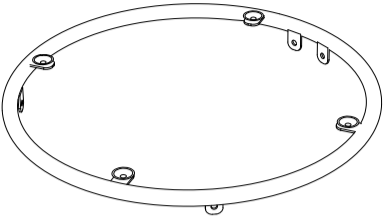
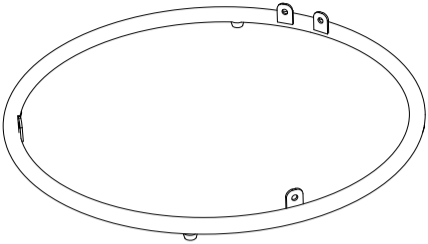
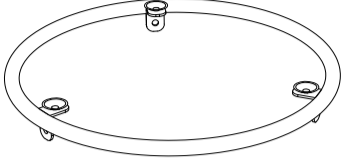
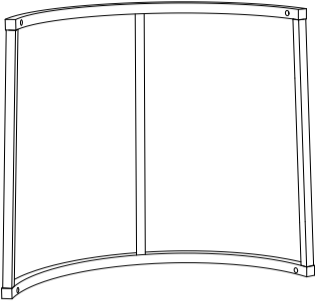
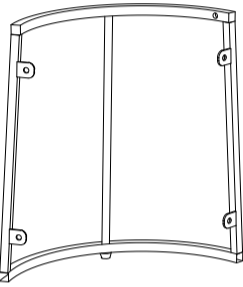
<p>U</p>  <p>Top Big Table (1 pc)</p>	<p>V</p>  <p>Bottom Big Table (1 pc)</p>	<p>X</p>  <p>Top Small Table (1 pc)</p>	<p>Y</p>  <p>Leg Big Table (2 pcs)</p>
<p>Z</p>  <p>Small Leg Table (3 pcs)</p>			

Hardware:

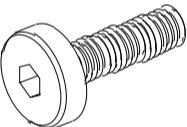
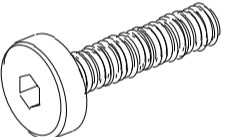
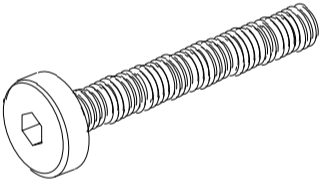
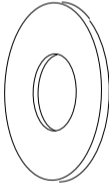
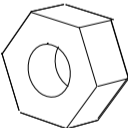
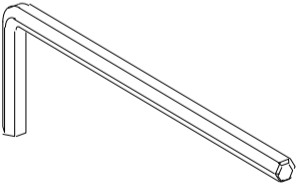
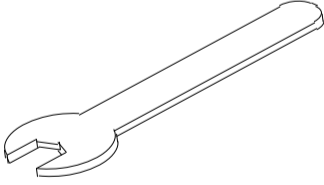
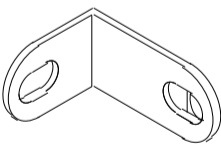
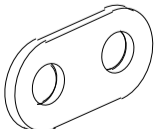
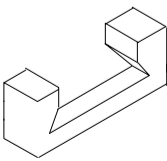
<p>1</p>  <p>Extra (6 pcs) Bolt M6x15 (63 pcs)</p>	<p>2</p>  <p>Extra (1pc) Bolt M6x20 (6 pcs)</p>	<p>3</p>  <p>Extra (4 pcs) Bolt M6x40 (40 pcs)</p>	<p>4</p>  <p>Extra (6 pcs) Flat Washer M6 (115 pcs)</p>
<p>5</p>  <p>Extra (1 pc) Eru M6 (6 pcs)</p>	<p>6</p>  <p>Allen Key (2 pcs)</p>	<p>7</p>  <p>Key (1 pc)</p>	<p>8</p>  <p>Square Collection (6 pcs)</p>
<p>9</p>  <p>Flat Collection (2 pcs)</p>	<p>10</p>  <p>U-Sharp Collection (1 pc)</p>		

Hardware: WF316572

This hardware is used for
WF316572 and WF316573

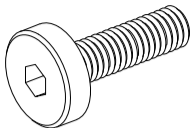
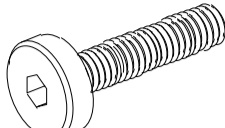
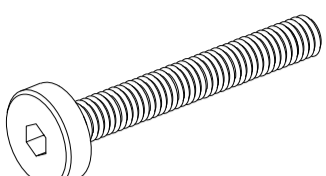
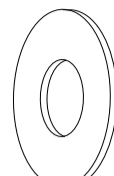
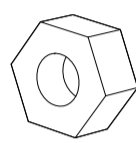
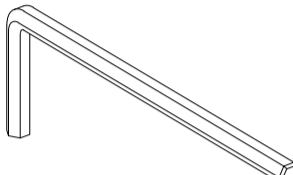
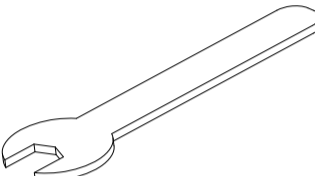
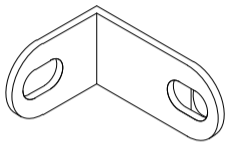
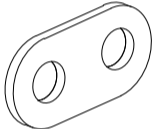
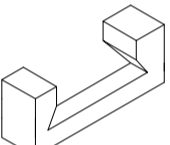
<p>1</p>  <p>Extra (3 pcs) Bolt M6x15 (31 pcs)</p>	<p>2</p>  <p>Extra (1 pc) Bolt M6x20 (6 pcs)</p>	<p>3</p>  <p>Extra (2 pcs) Bolt M6x40 (20 pcs)</p>	<p>4</p>  <p>Extra (3 pcs) Flat Washer M6 (63 pcs)</p>
<p>5</p>  <p>Extra (1 pc) Eru M6 (6 pcs)</p>	<p>6</p>  <p>Allen Key (1 pc)</p>	<p>7</p>  <p>Key (1 pc)</p>	<p>8</p>  <p>Square Collection (2 pcs)</p>
<p>9</p>  <p>Flat Collection (2 pcs)</p>	<p>10</p>  <p>U-Sharp Collection (1 pc)</p>		

Hardware: WF316574

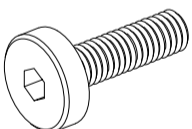
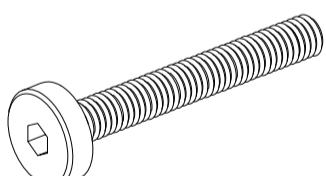
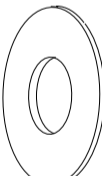
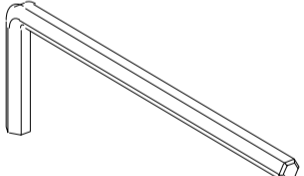
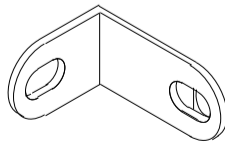
<p>1</p>  <p>Extra (3 pcs) Bolt M6x15 (32 pcs)</p>	<p>3</p>  <p>Extra (2 pcs) Bolt M6x40 (20 pcs)</p>	<p>4</p>  <p>Extra (3 pcs) Flat Washer M6 (52 pcs)</p>	<p>6</p>  <p>Allen Key (1 pc)</p>
<p>8</p>  <p>Square Collection (4 pcs)</p>			

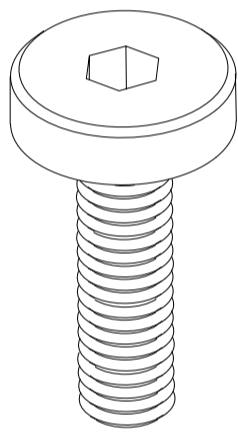

**BOLT
M6x15 MM**

1

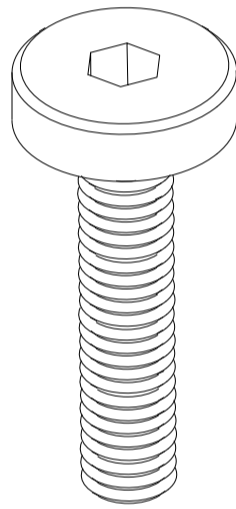

**BOLT
M6x20 MM**

2

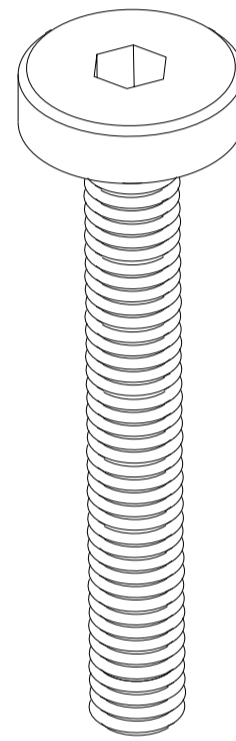

**BOLT
M6x40 MM**

3

Please note that the shapes of bolts 1 and 2 and 3 are similar.
Please install according to the instructions and distinguish them!

CARTON CONTENT:

WF316572

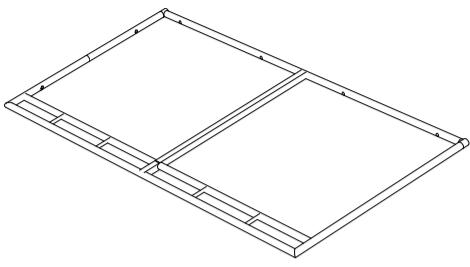

A x1

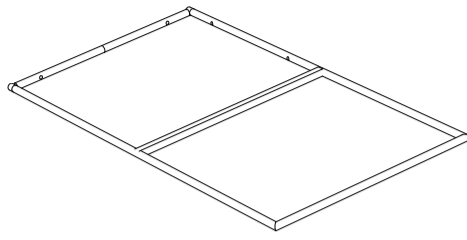

B x1

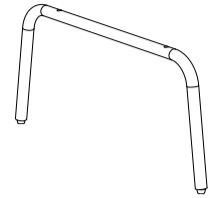

J x2

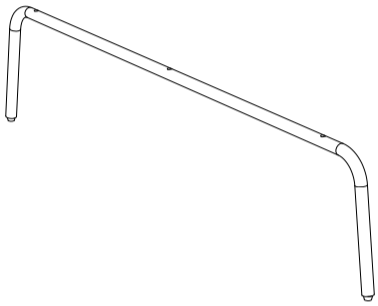

I x2

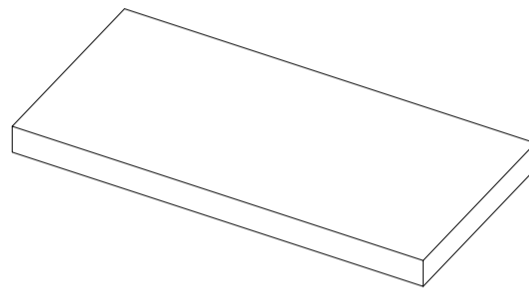

O x2

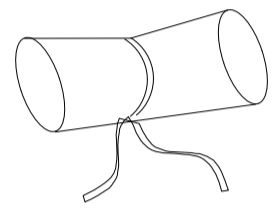

Hardware

WF316573

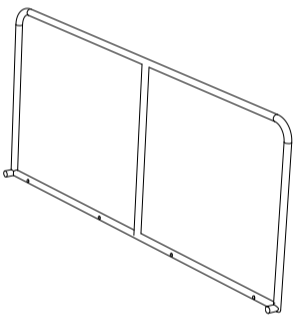

D x1

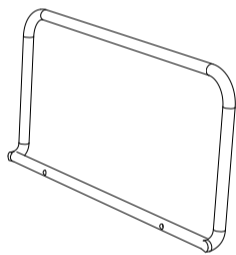

G x1

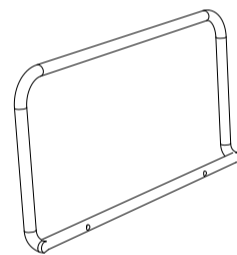

H x1



K x2

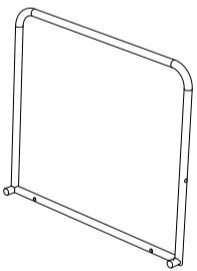

E x1

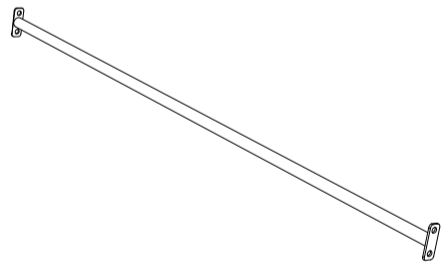

L x2

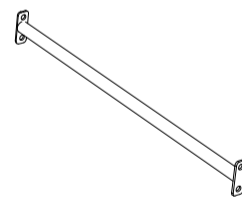

N x2

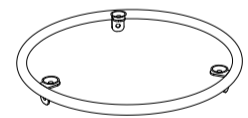

X x1

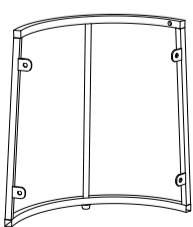

Z x3

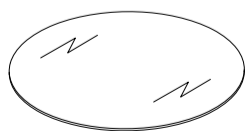

T x1

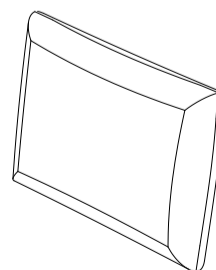

P x3

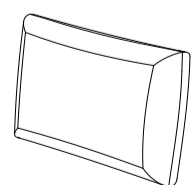

Q x2

CARTON CONTENT:

WF316574

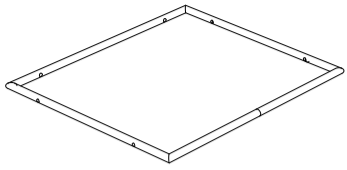

C x2

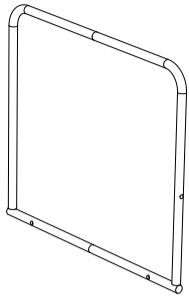

F x2

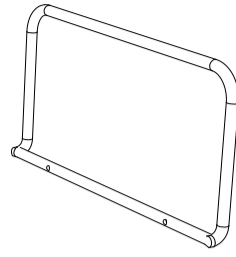

G x2

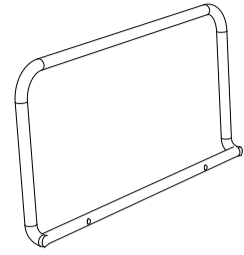

H x2

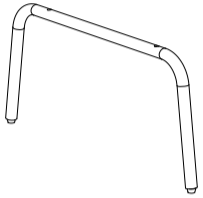

J x4

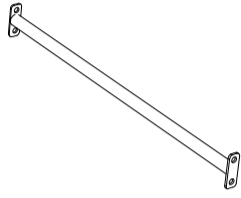

M x4

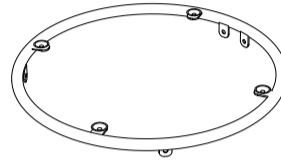

U x1

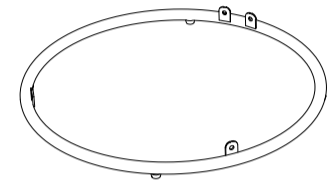

V x1

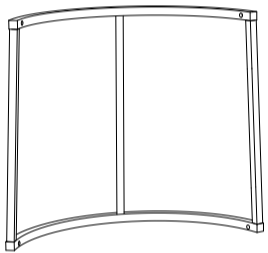

Y x2

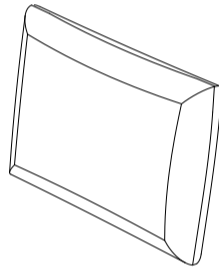

P x2

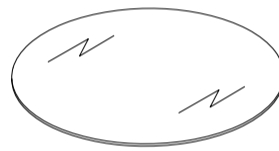

R x1

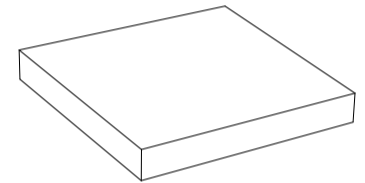

S x2

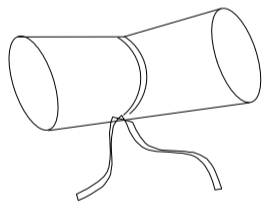

Hardware

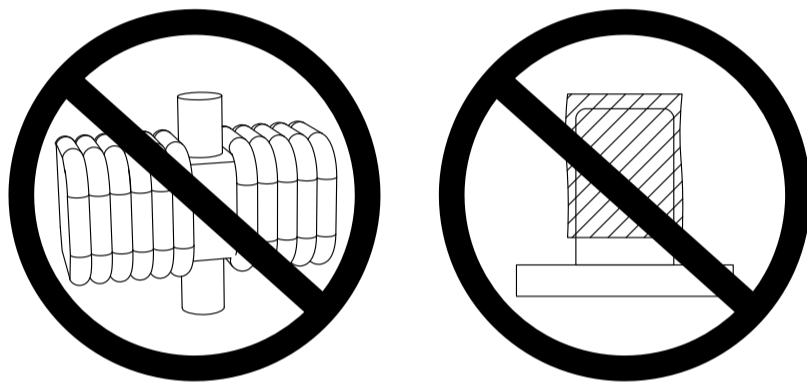

**PLEASE REMOVE PIPE PIN & PROTECTIVE PIECES
ON THE PART LIST BEFORE ASSEMBLING**

STEP 1

A x1

D x1

3 x4

4 x4

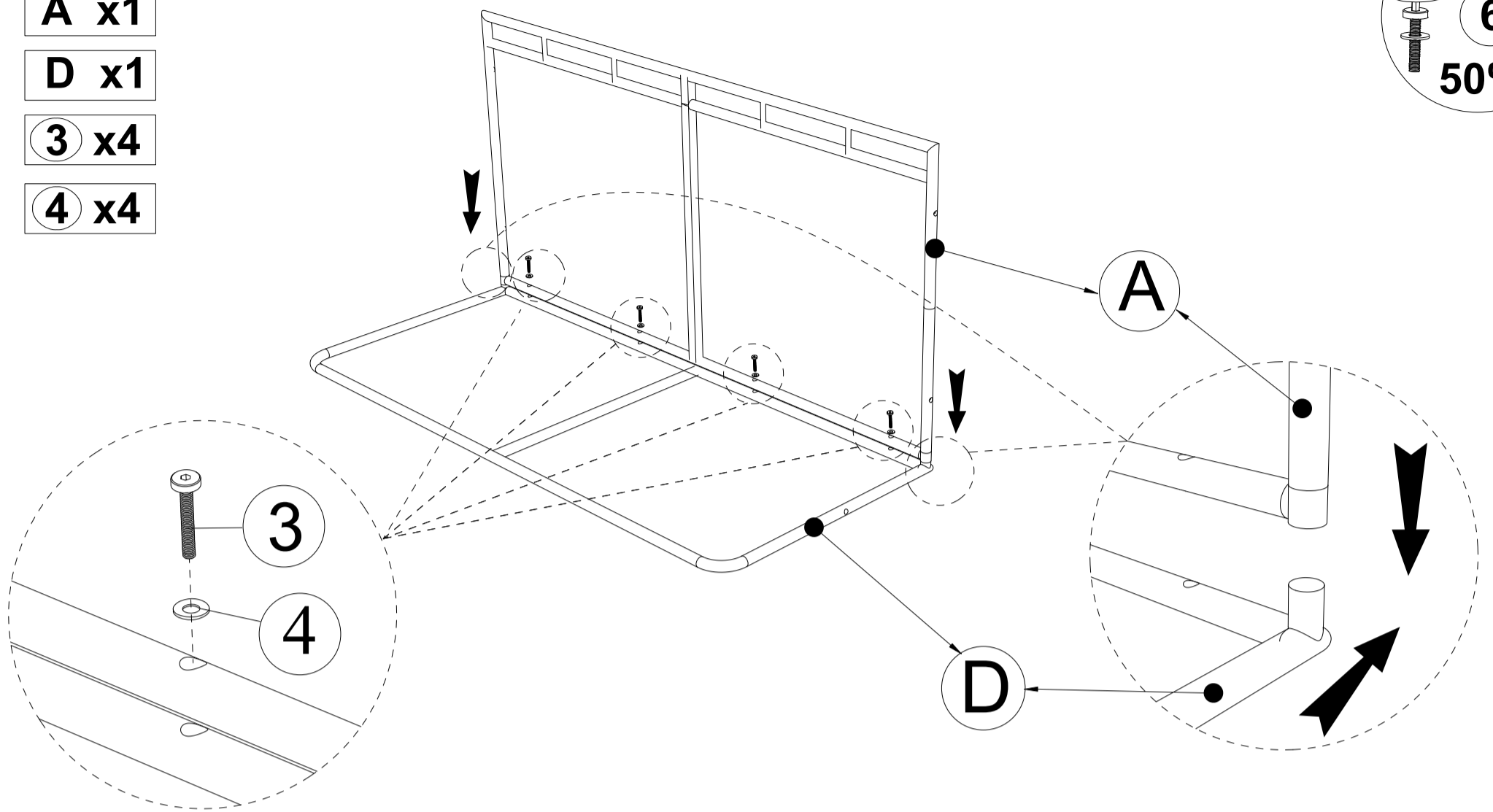
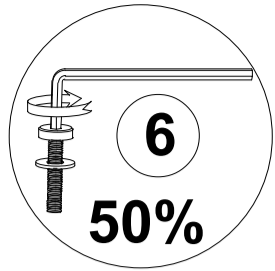

Push & Connect Seat Bench 1 (A) & Long Back Bench (D), tighten Bolt (3) & Flat washer (4) with Allen Key (6)

STEP 2

H x1

3 x2

4 x2

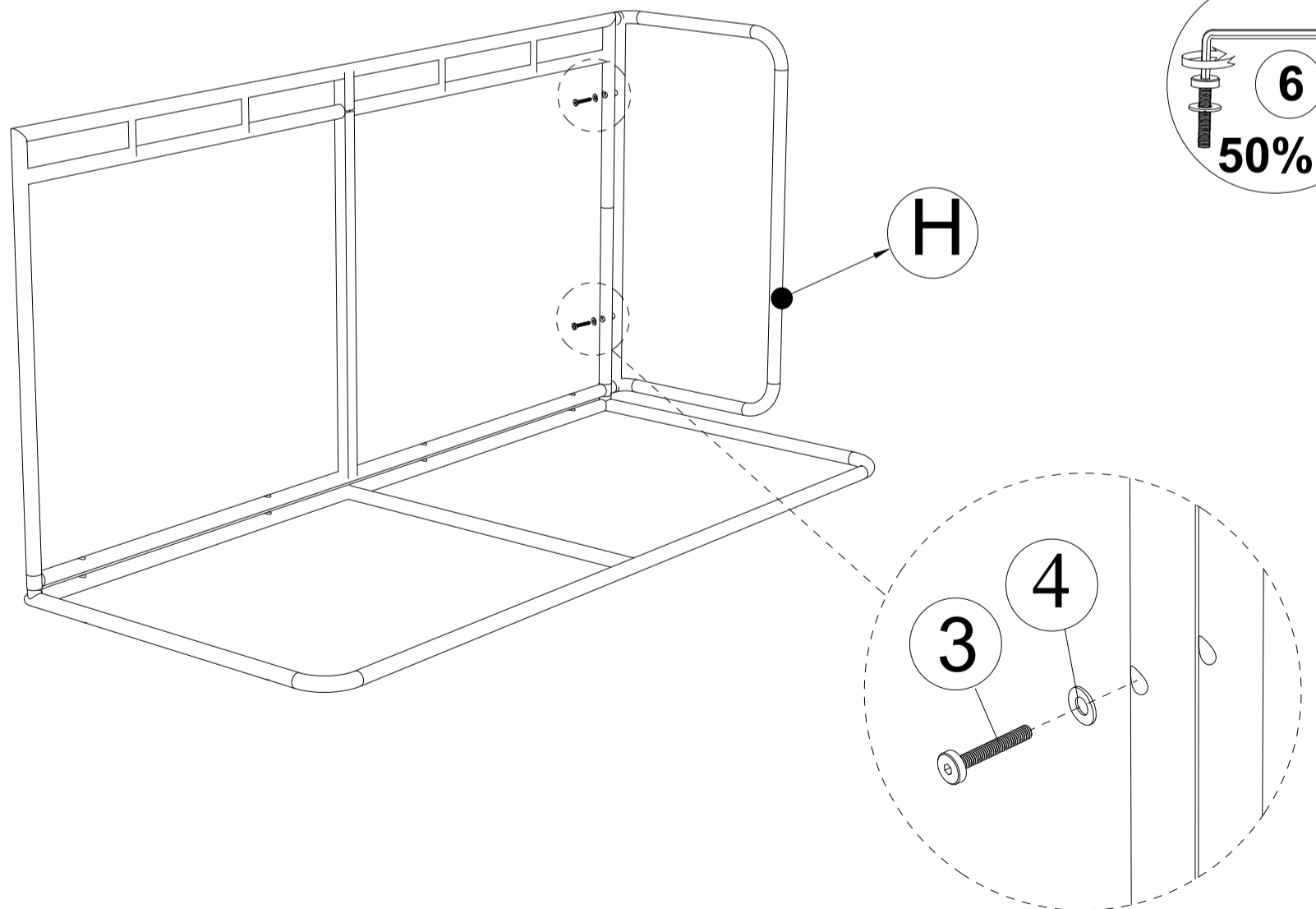
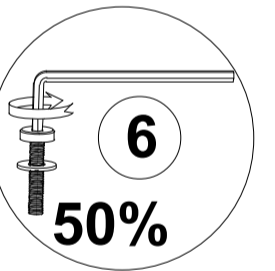

Connect the part from step 1 & Right Arm (H), tighten Bolt (3) & Flat washer (4) with Allen Key (6).

STEP 3

J x2

3 x4

4 x4

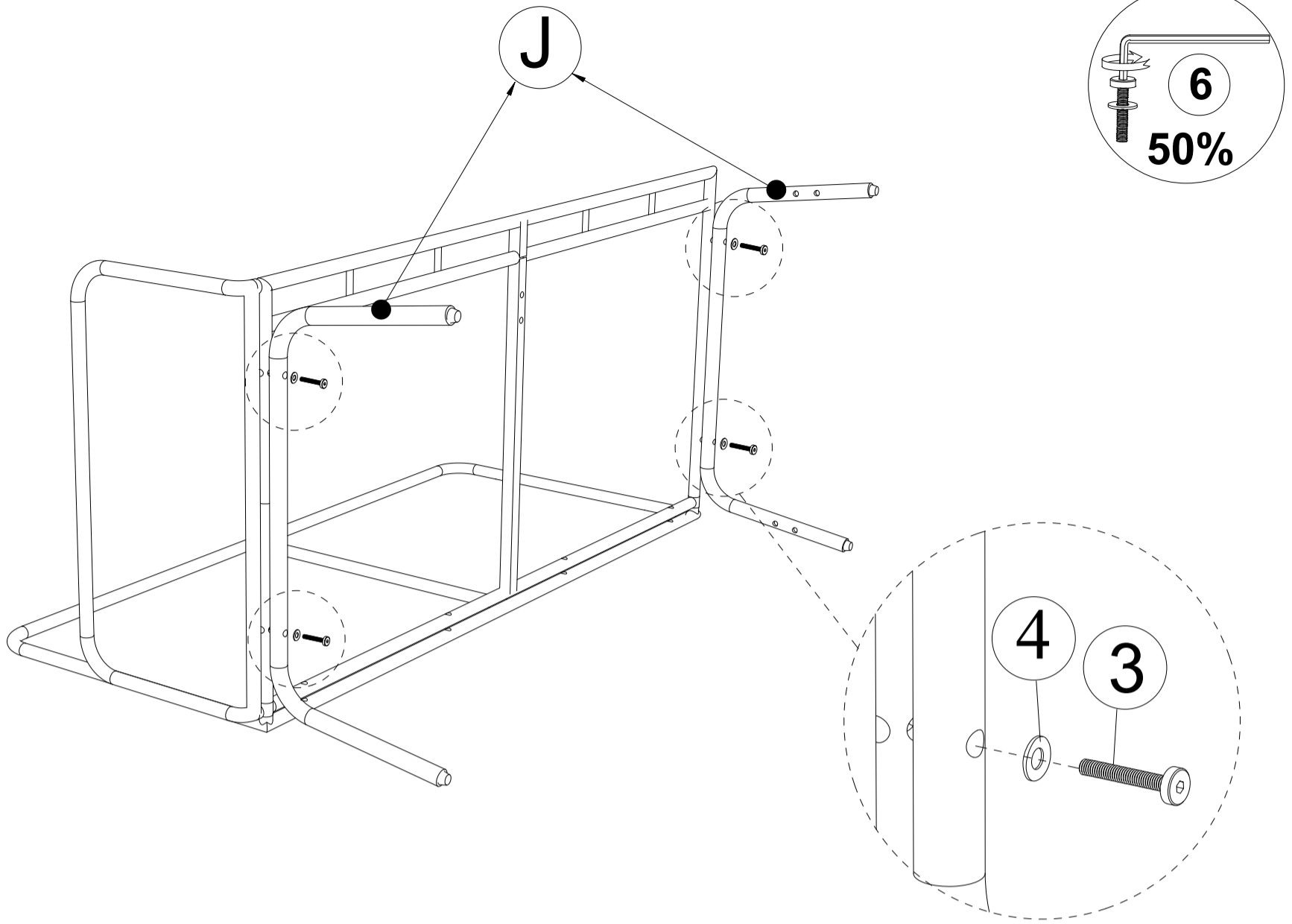

Connect the part from step 2 & Short Leg (J), tighten Bolt (3) & Flat washer (4) with Allen Key (6).

STEP 4

L x2

1 x8

4 x8

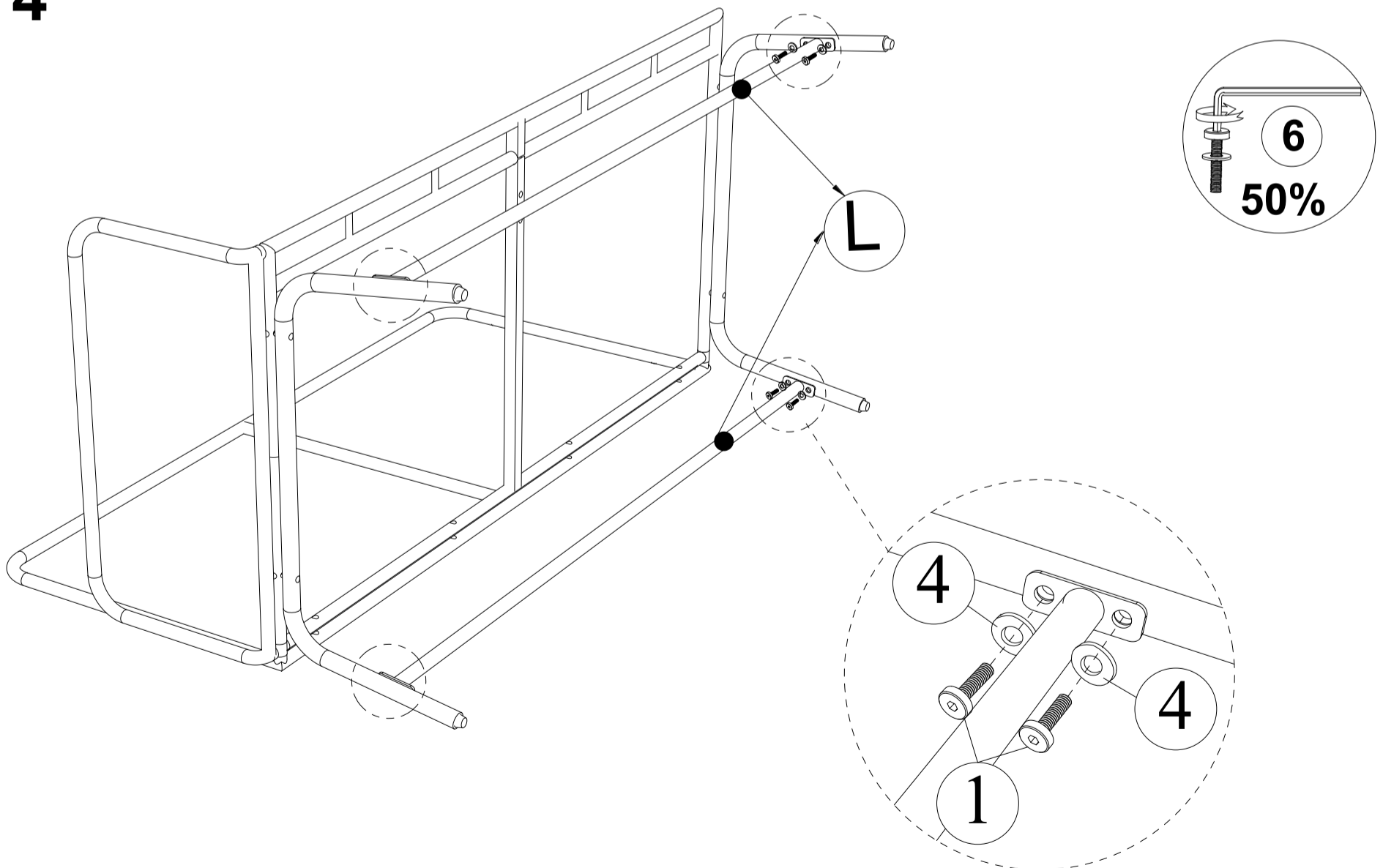

Connect the part from step 3 & Long Collection (L), tighten Bolt (1) & Flat Washer (4) with Allen Key (6).

STEP 5

K x1

1 x2

4 x2

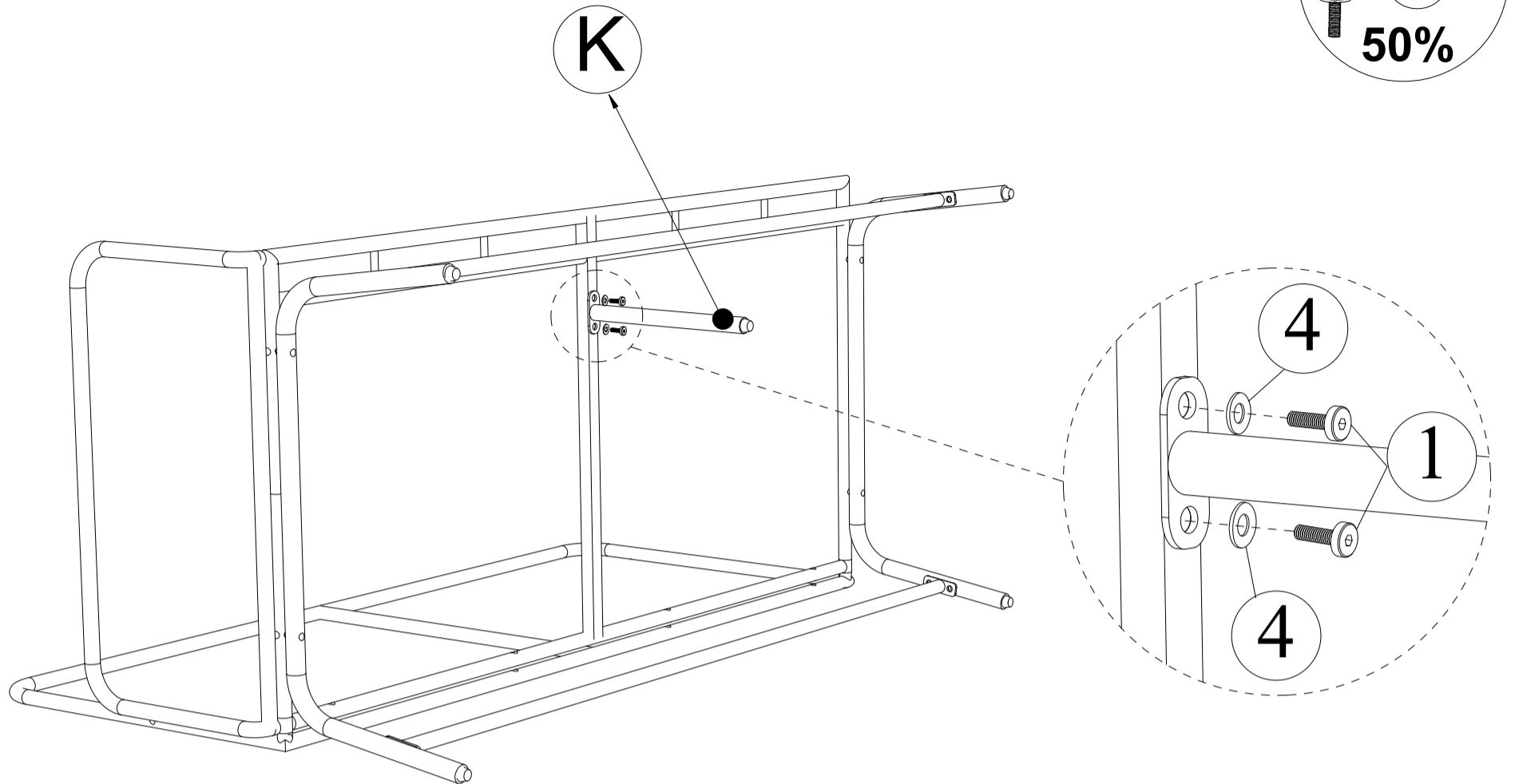

Connect The part from Step 4 & Support Leg (K), tighten Bolt (1) & Flat Washer (4) with Allen Key (6).

STEP 6

8 x1

1 x2

4 x2

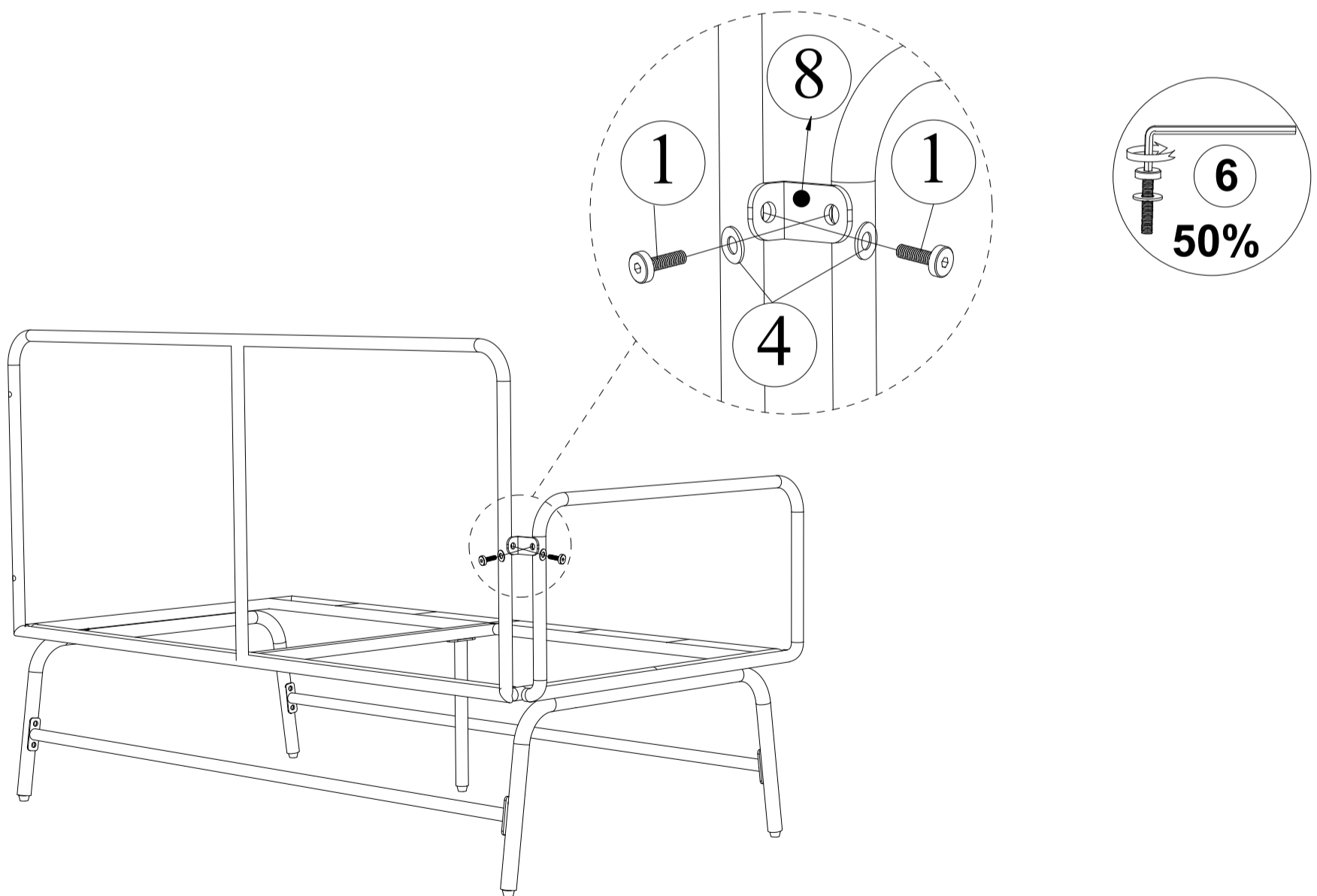

Put The part from Step 5 upright & Connect Square Collection (8), tighten Bolt (1) & Flat Washer (4) with Allen Key (6).

STEP 7

RIGHT BENCH FRAME

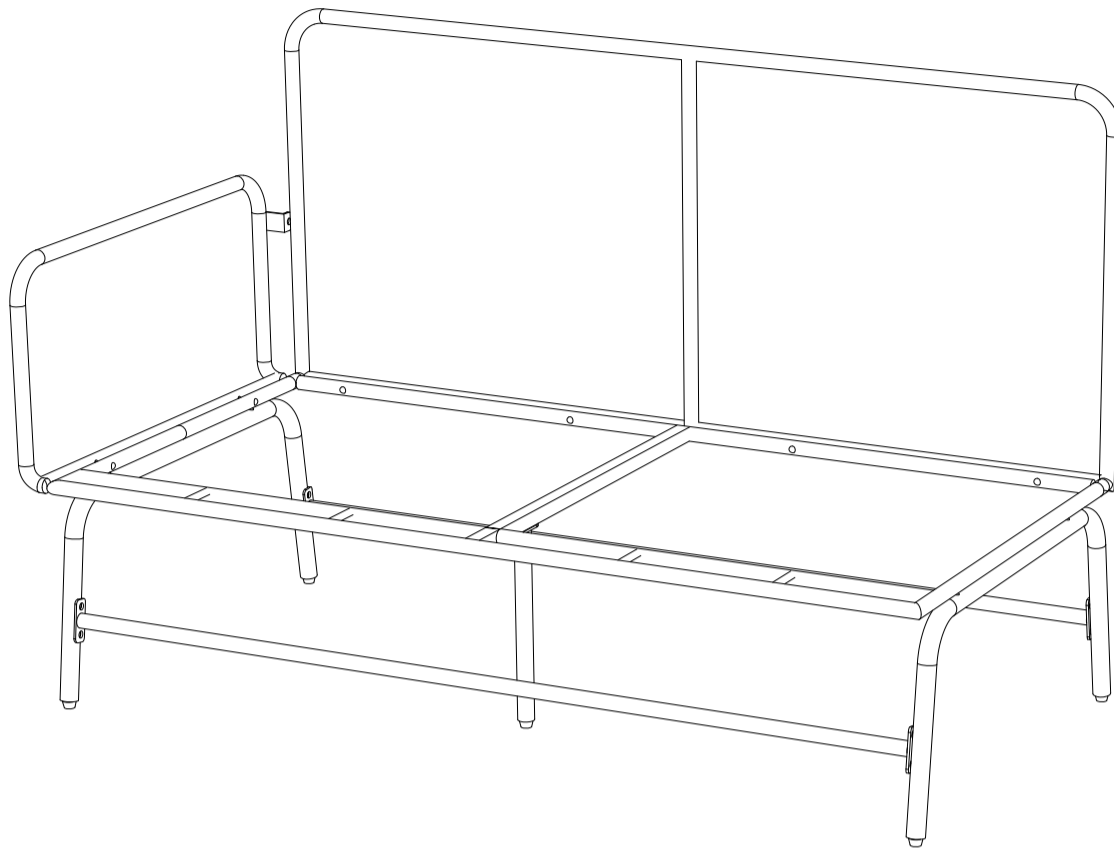
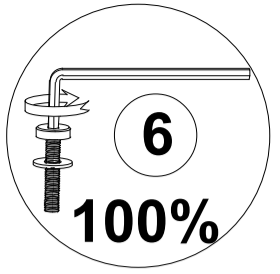

Firmly, tighten Bolts with Allen Key (6) & Finish Right Bench Frame

STEP 8

REMOVE
THE PROTECTION
ON THE PIECE

B x1

E x1

3 x2

4 x2

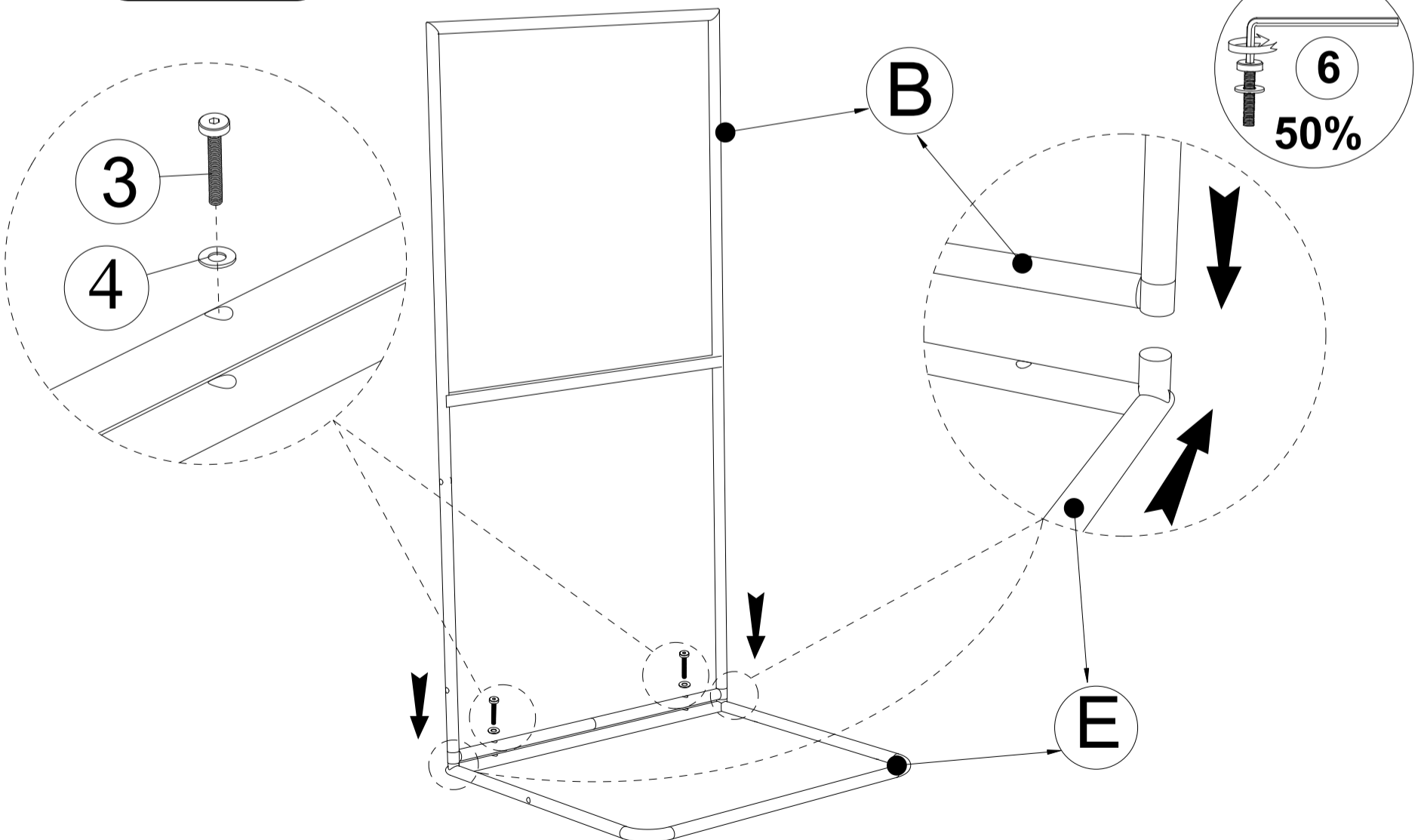

Push & Connect Seat Bench 2 (B) & Long Back Bench (E), tighten Bolt (3) & Flat washer (4) with Allen Key (6)

STEP 9

G x1

3 x2

4 x2

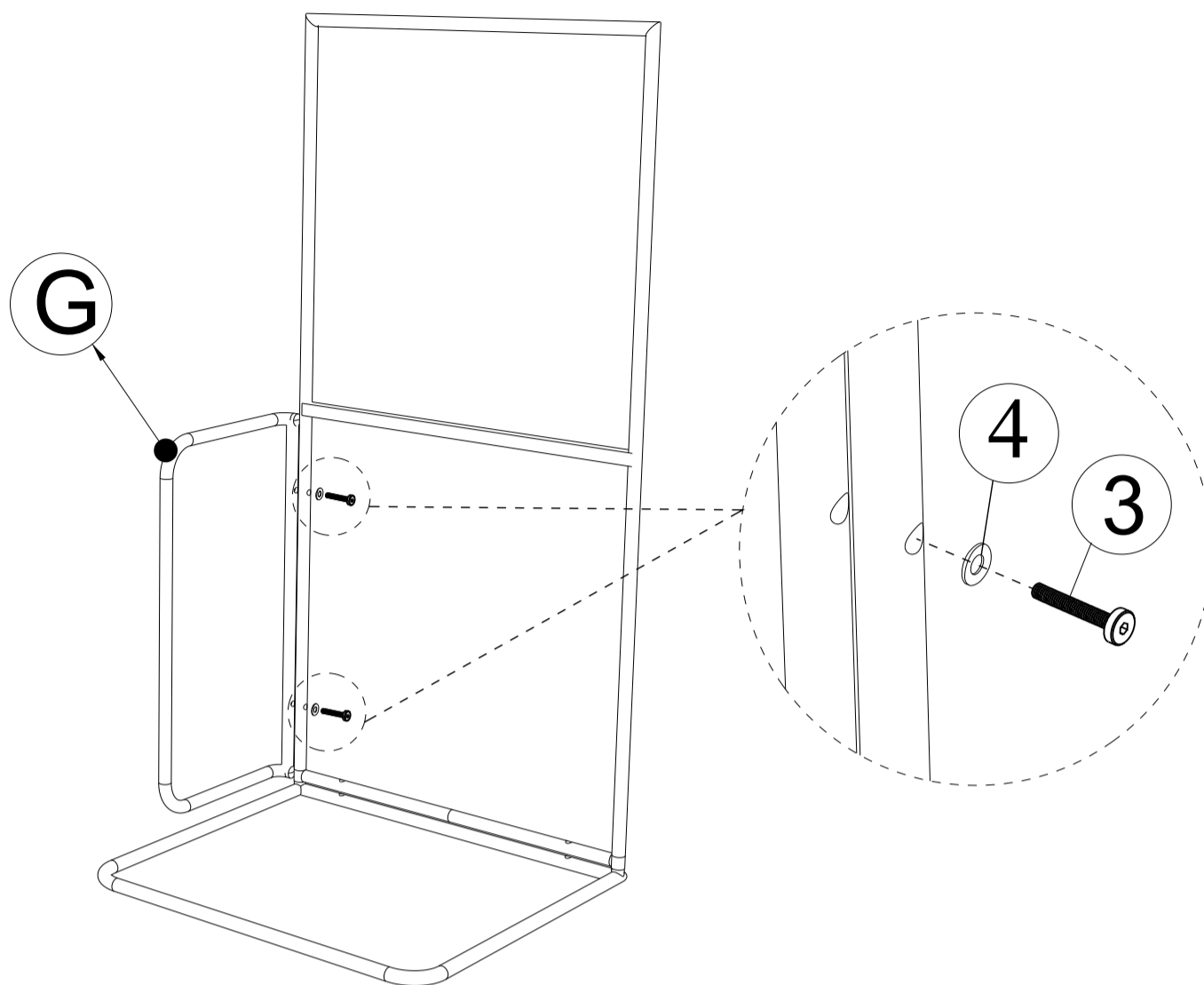
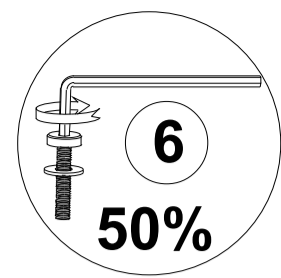

Connect The part from Step 8 & Left Arm (G), tighten Bolt (3) & Flat Washer (4) with Allen Key (6).

STEP 10

I x2

3 x6

4 x6

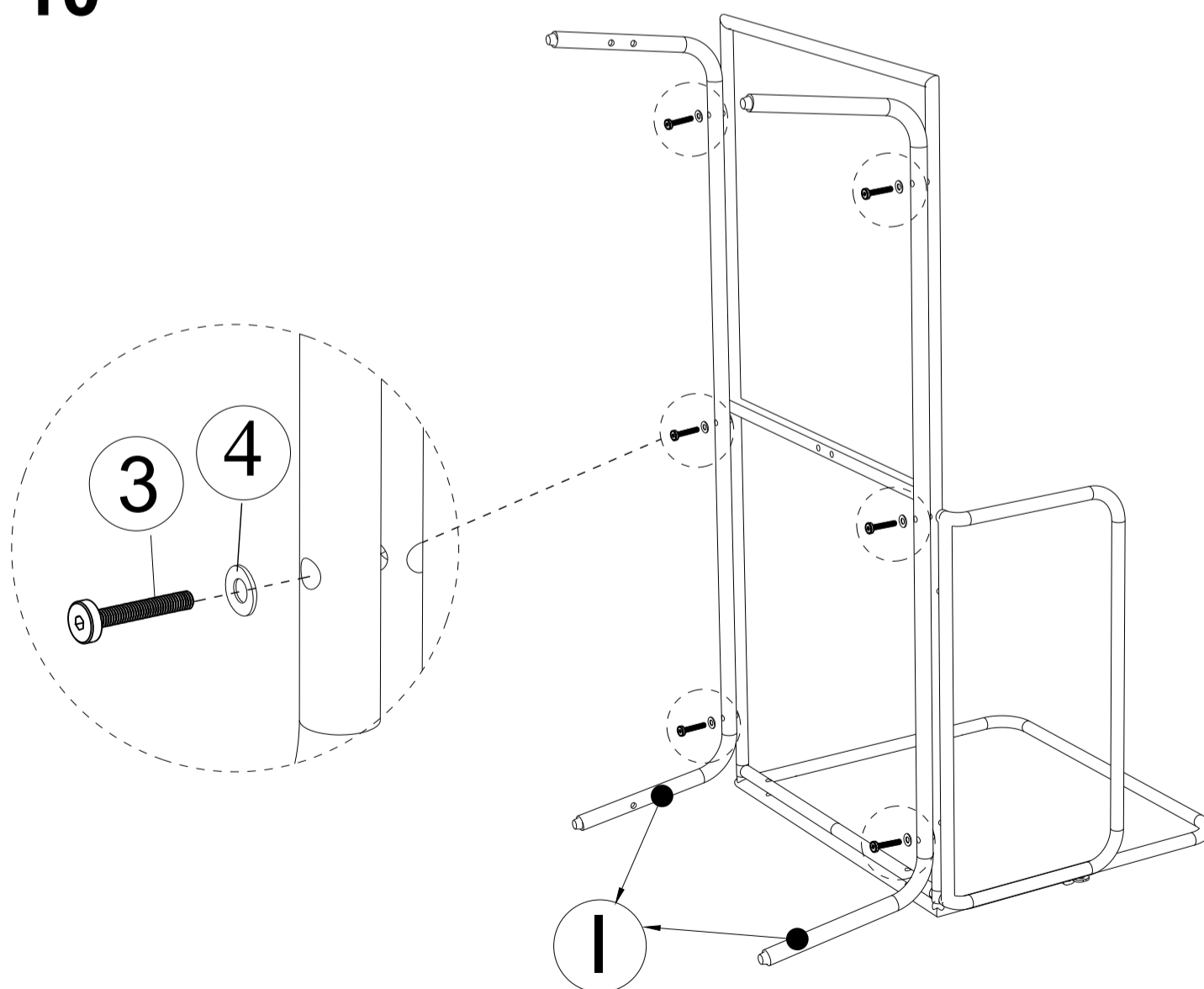
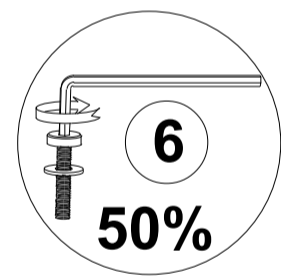

Connect the part from step 9 & Long Leg (I), tighten Bolt (3) & Flat Washer (4) & Allen Key (6).

STEP 11

N x2

1 x8

4 x8

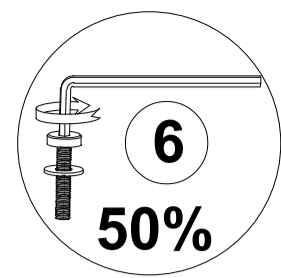
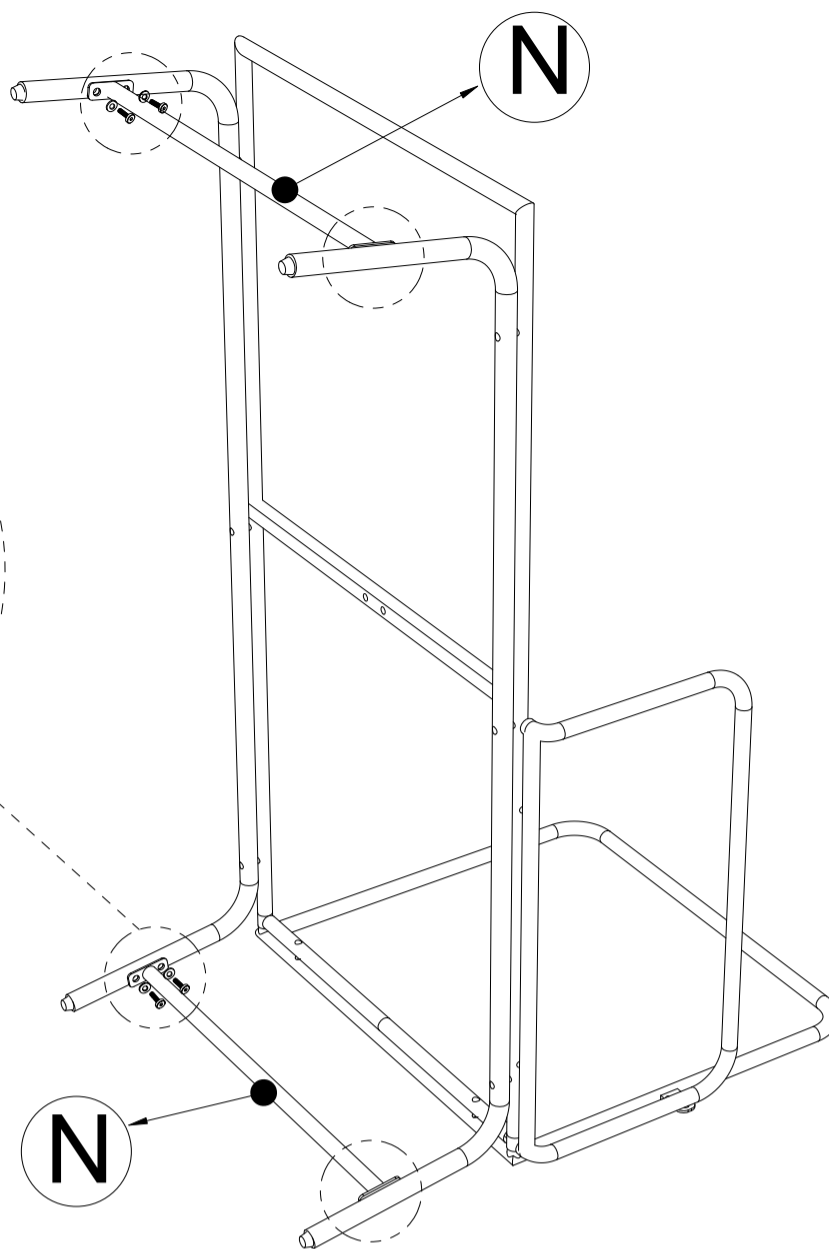
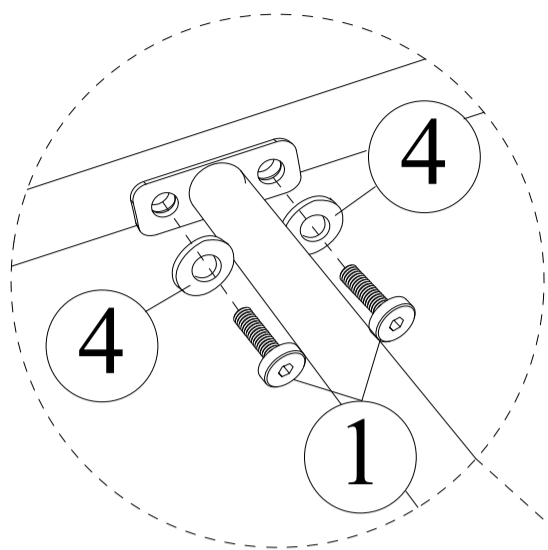

Connect the part from step 10 & Short Collection 1 (N), tighten Bolt (1) & Flat Washer (4) & Allen Key (6).

STEP 12

K x1

1 x2

4 x2

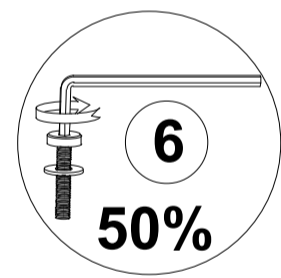
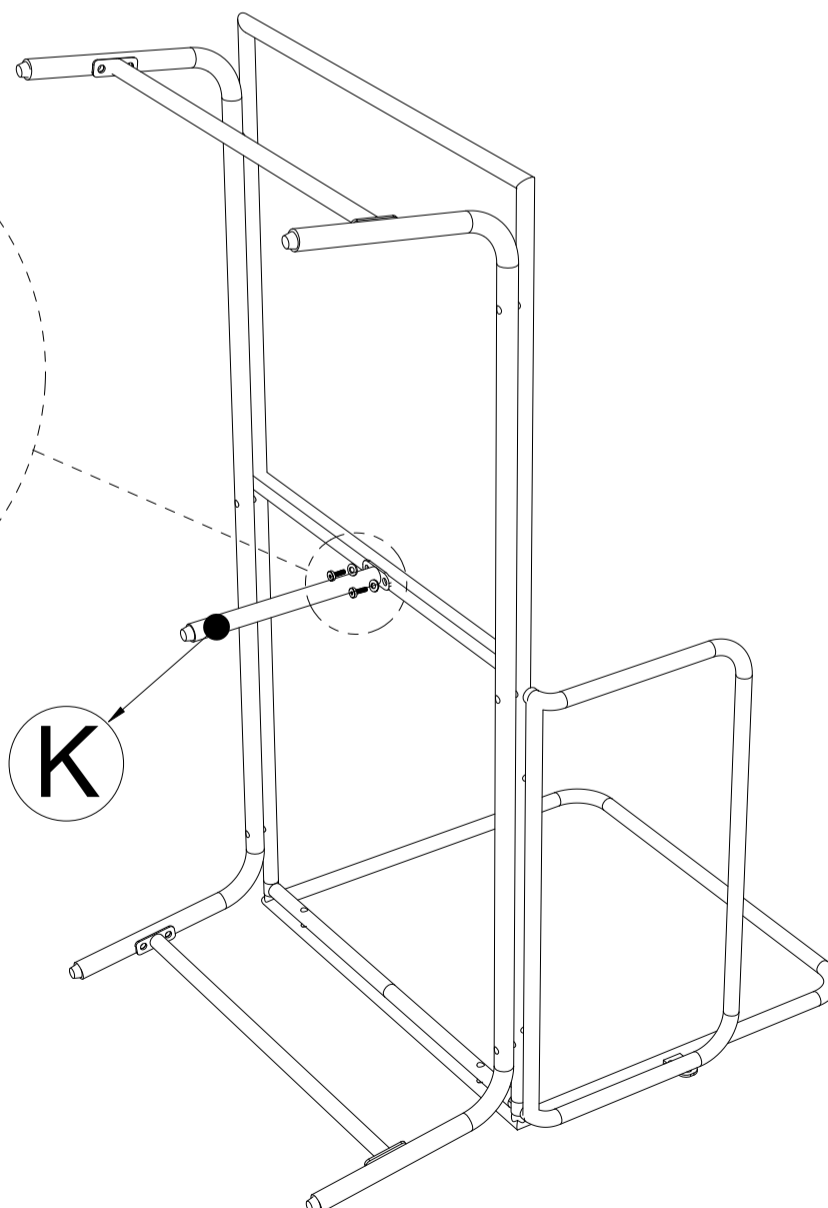
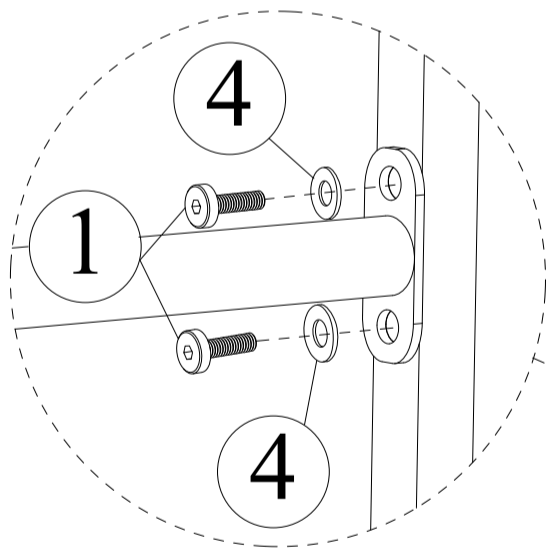

Connect The part from Step 11 & Support Leg (K), tighten Bolt (1) & Flat Washer (4) with Allen Key (6).

STEP 13

8 x1

1 x2

4 x2

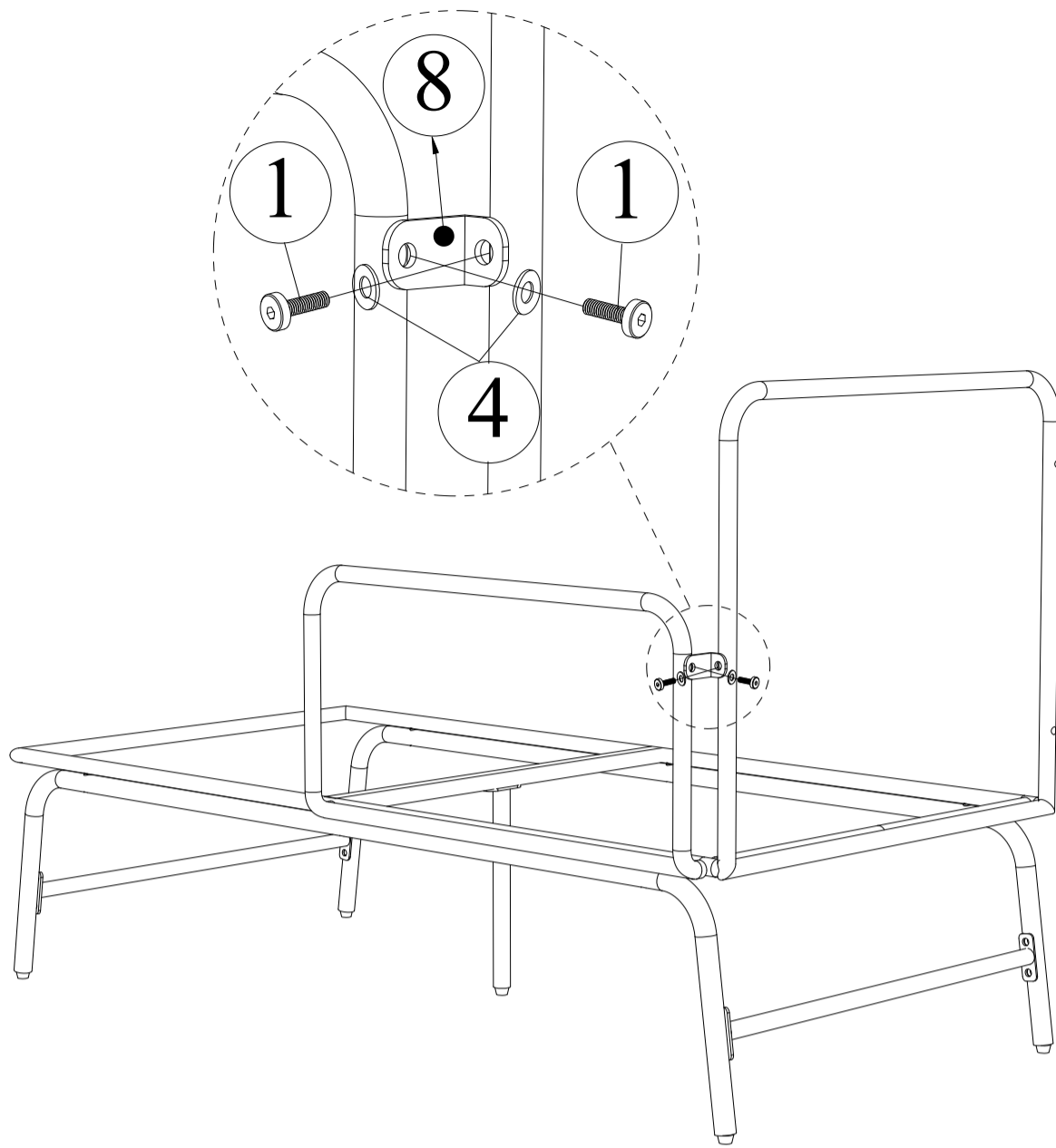

Put The part from Step 12 upright & Connect Square Collection (8), tighten Bolt (1) & Flat Washer (4) with Allen Key (6).

STEP 14

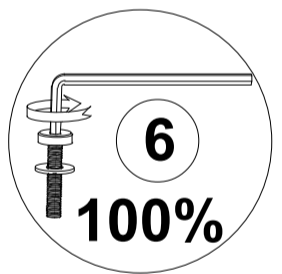
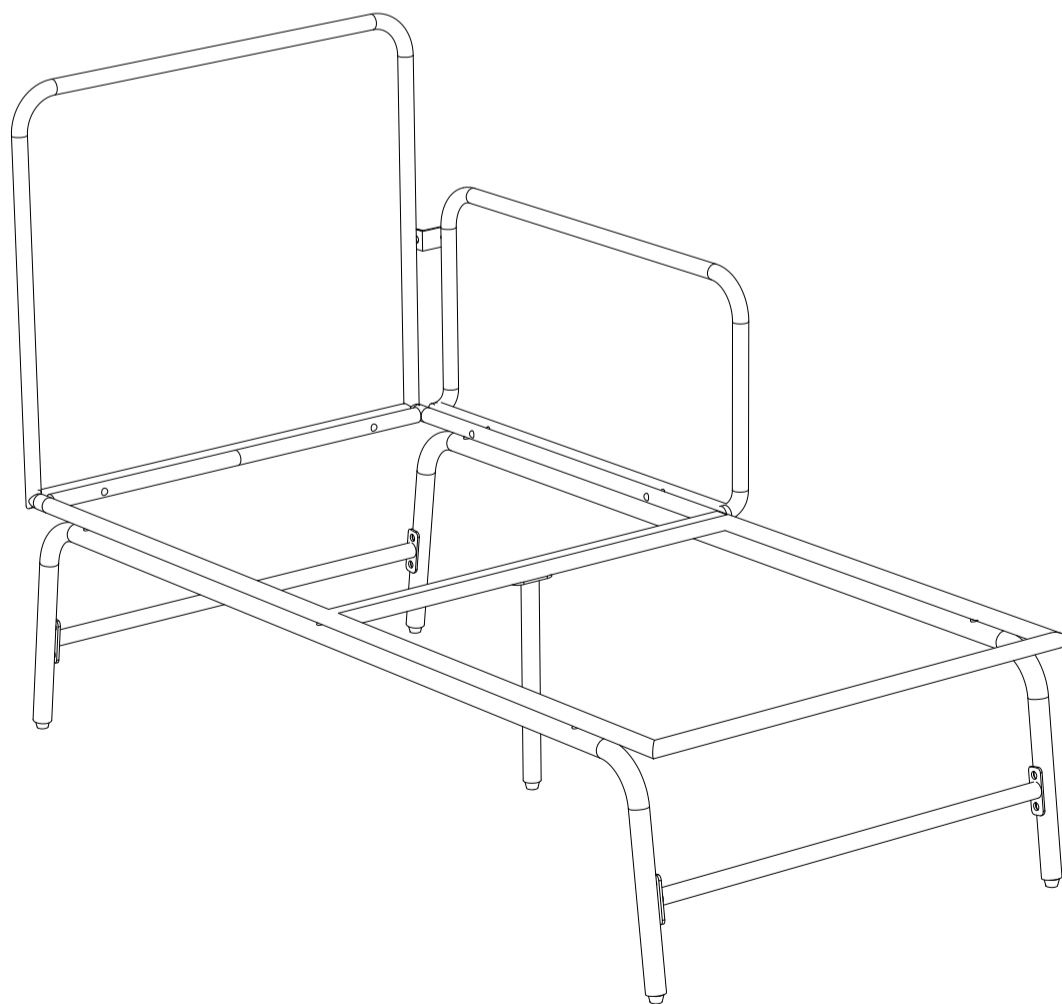

Firmly, tighten Bolts with Allen Key (6) & Finish Left Bench Frame

STEP 15

9 x2

10 x1

1 x4

4 x4

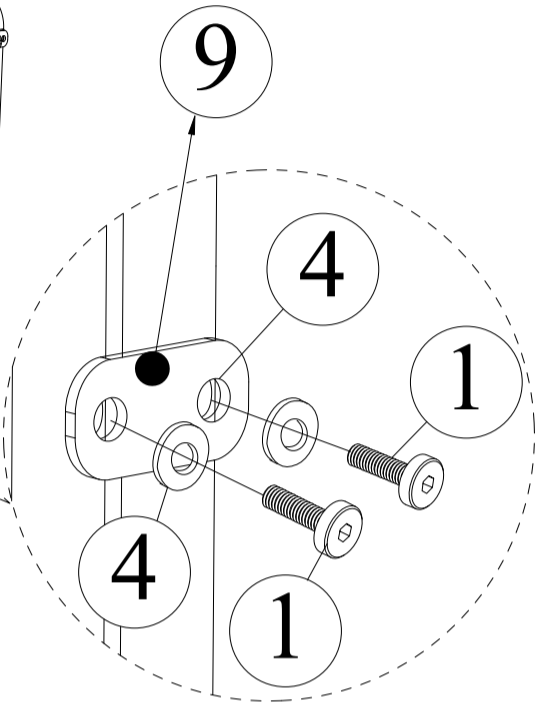
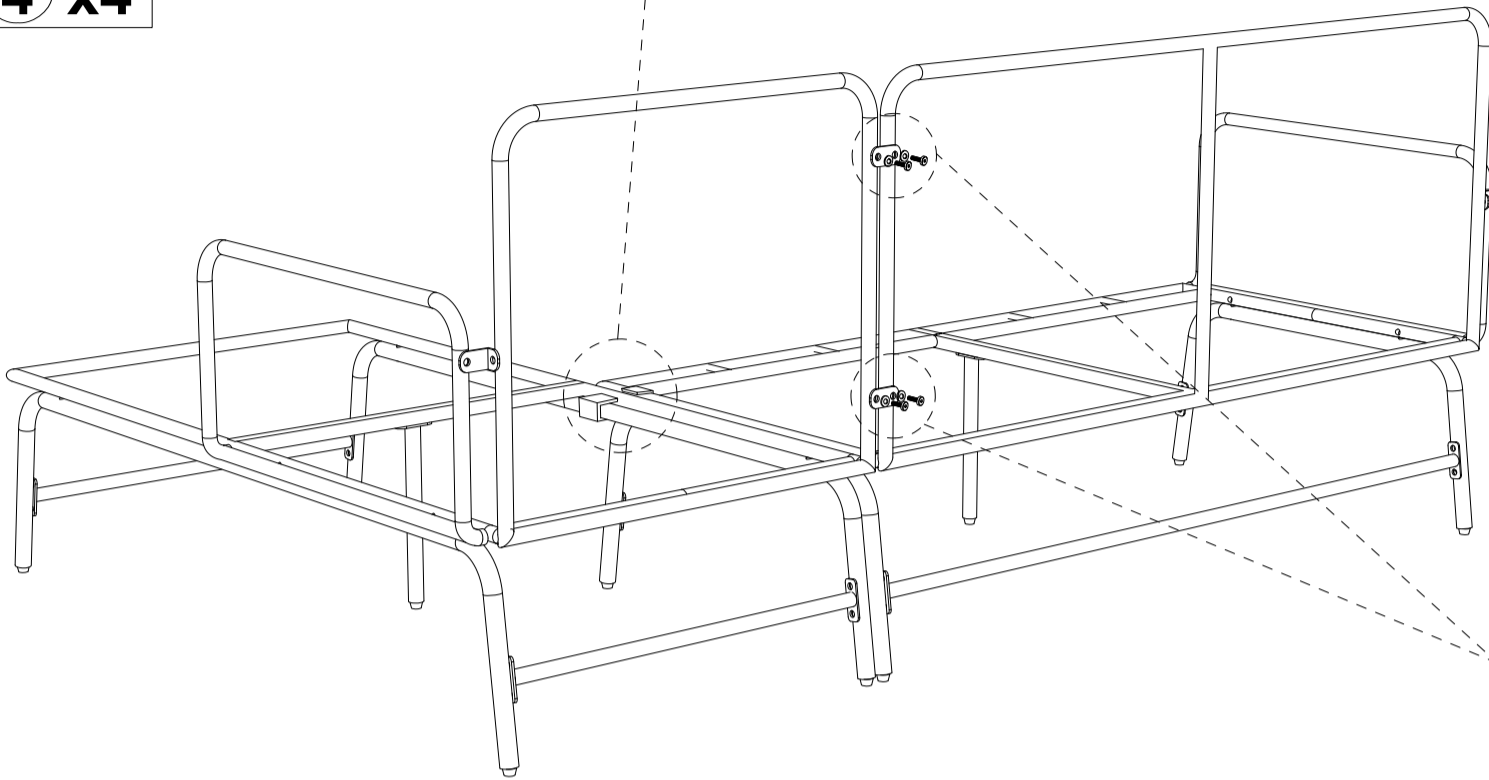
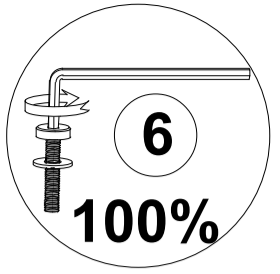
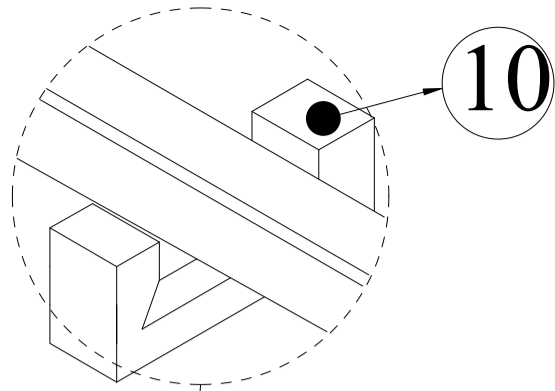

Connect the part from step 14, the part from step 7 & Flat Collection (9), & U-sharp Collection (10), tighten Bolt (1) & Flat Washer (4) with Allen Key (6).

STEP 16

O x2

P x3

Q x2

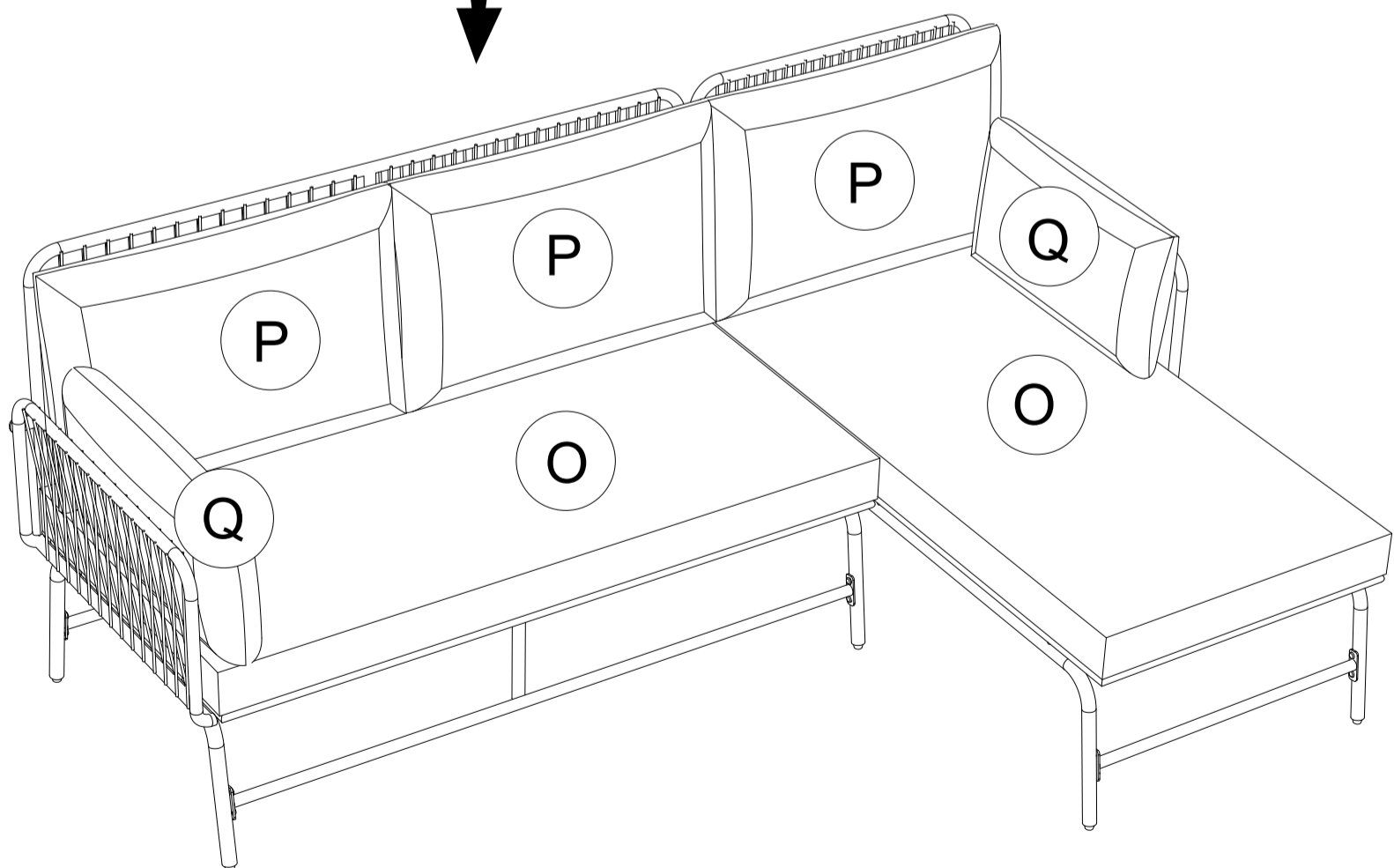
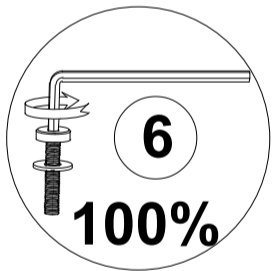

Set up the Cushions (O)+(P)+(Q) to finish Corner Set.

STEP 17

- Z x3
- 2 x6
- 4 x12
- 5 x6

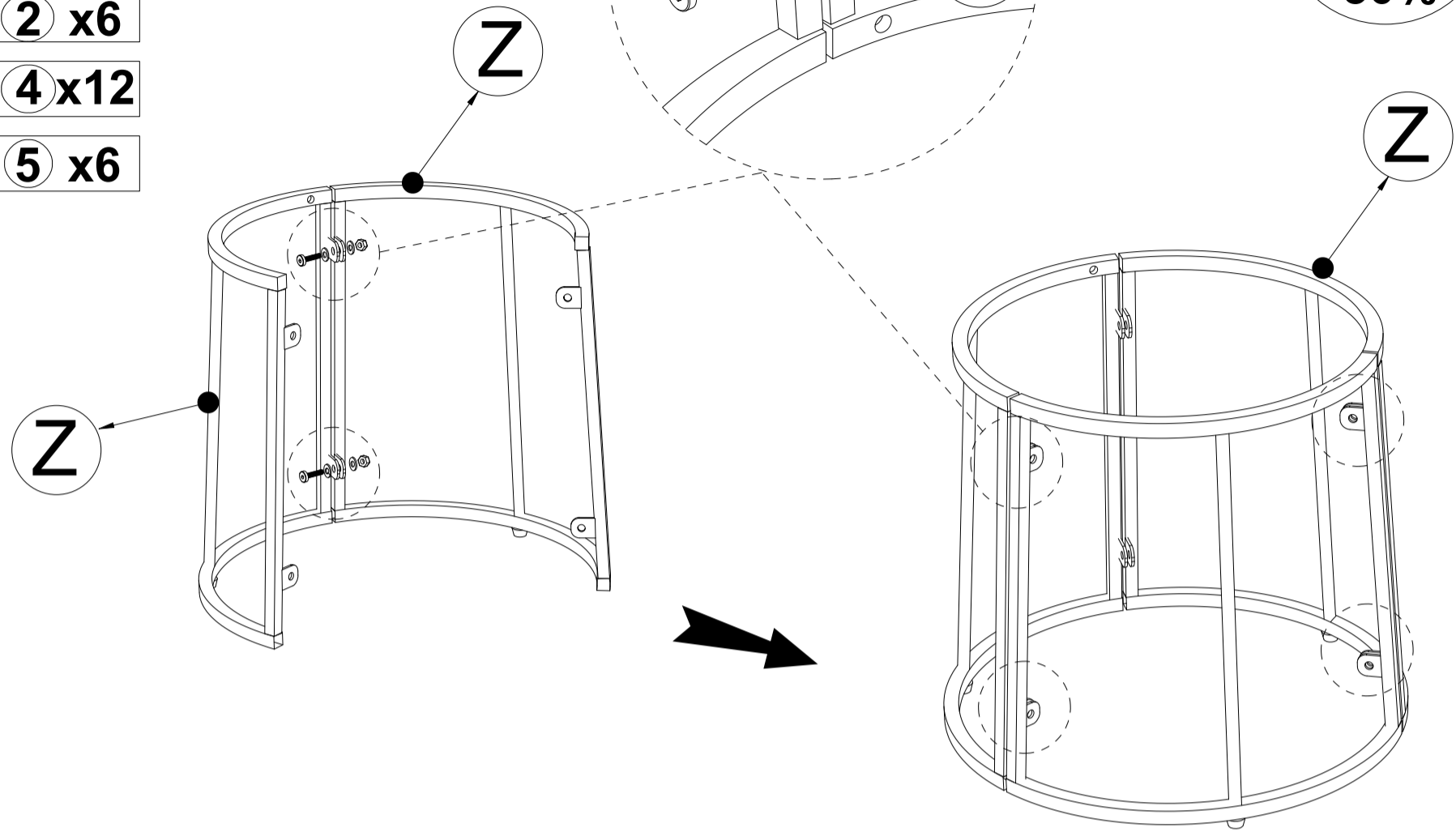
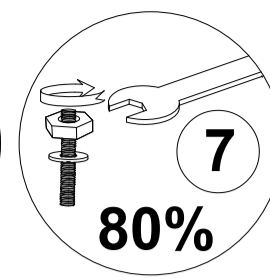
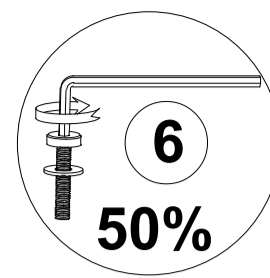
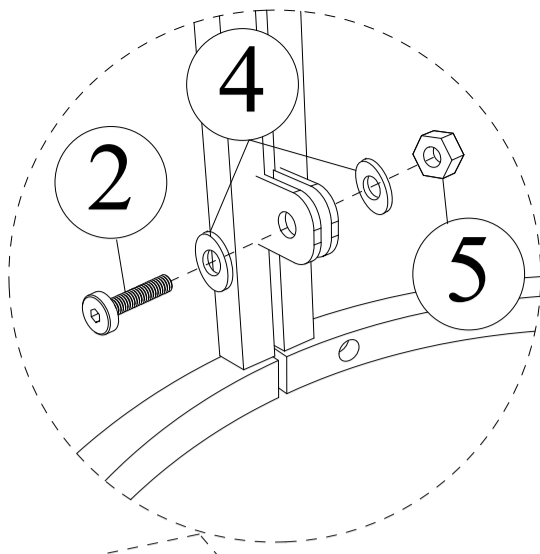

Connect all the Leg Small Table (Z) together. tighten Bolt (2) & Flat Washer (4), Eru (5) with Allen Key (6) & Key (7).

STEP 18

- X x1
- 1 x3
- 4 x3

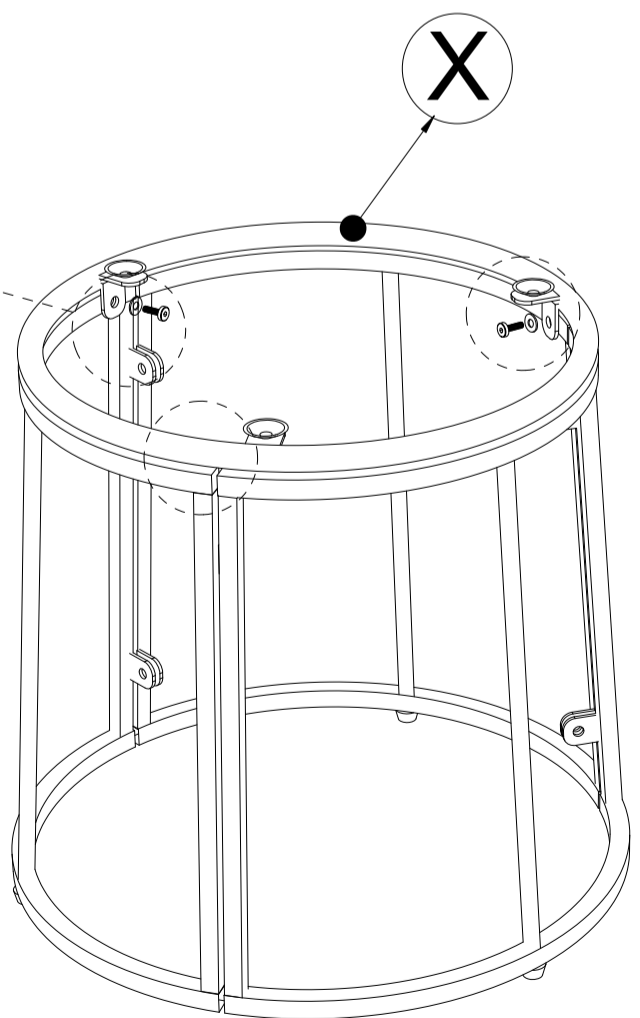
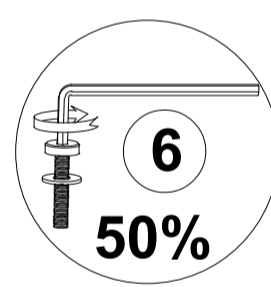
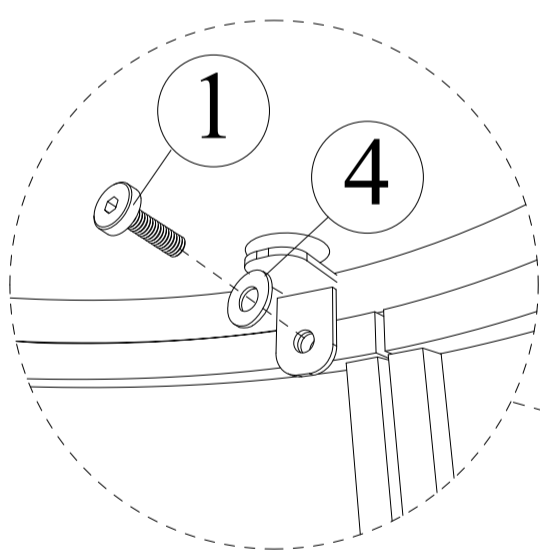

Connect the part from step 17 & Top Small Table (X), tighten Bolt (1) & Flat Washer (4) with Allen Key (6).

STEP 19

T x1

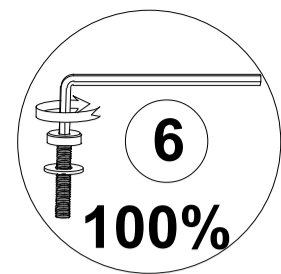
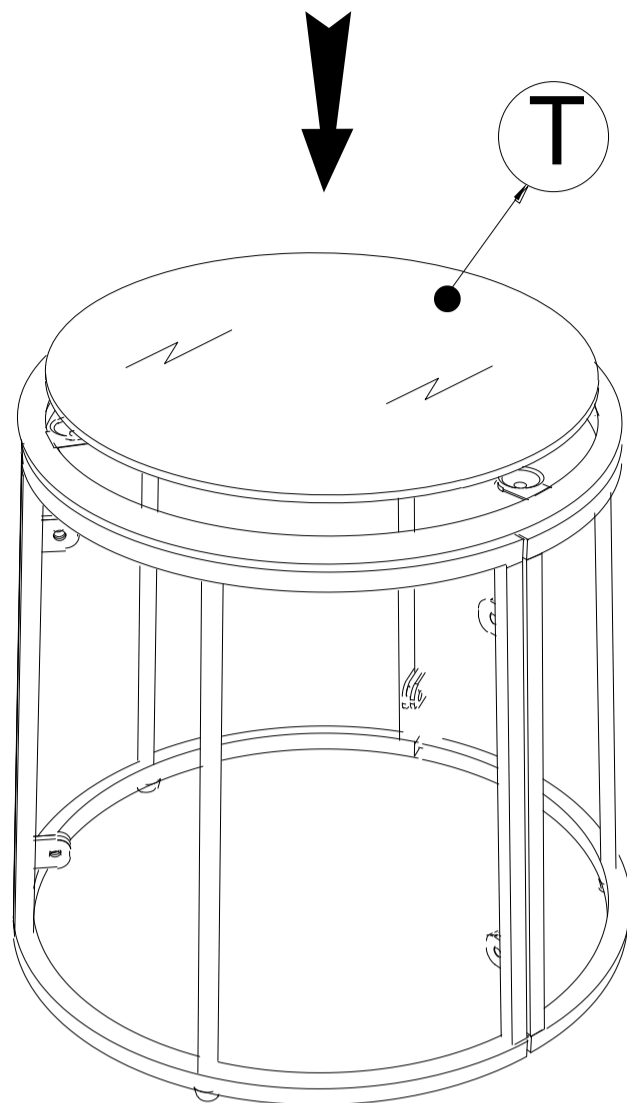

Firmly, tighten Bolts with Allen Key (6) Put the Small Glass Top (T) on the top frame.

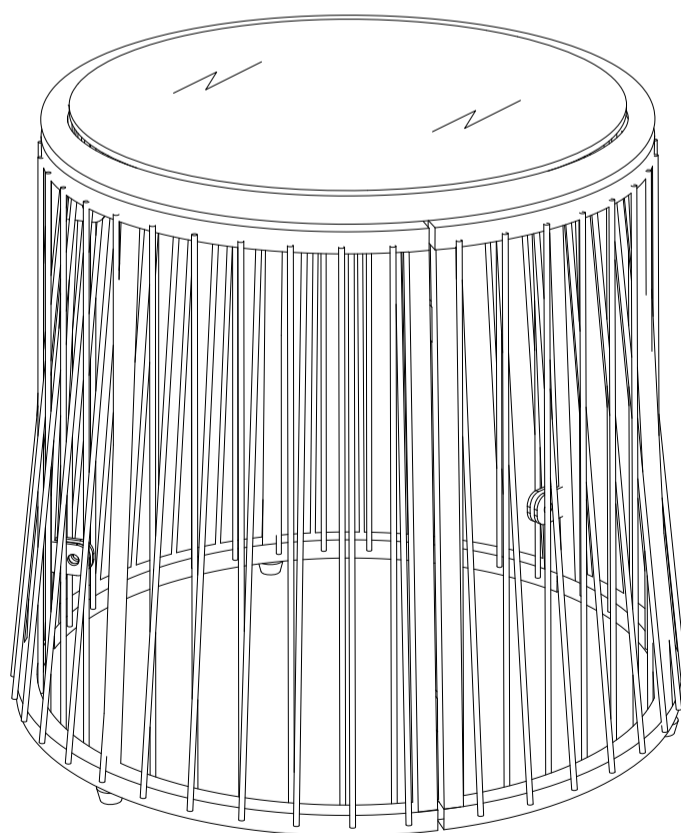

Finish Small Table

STEP 20

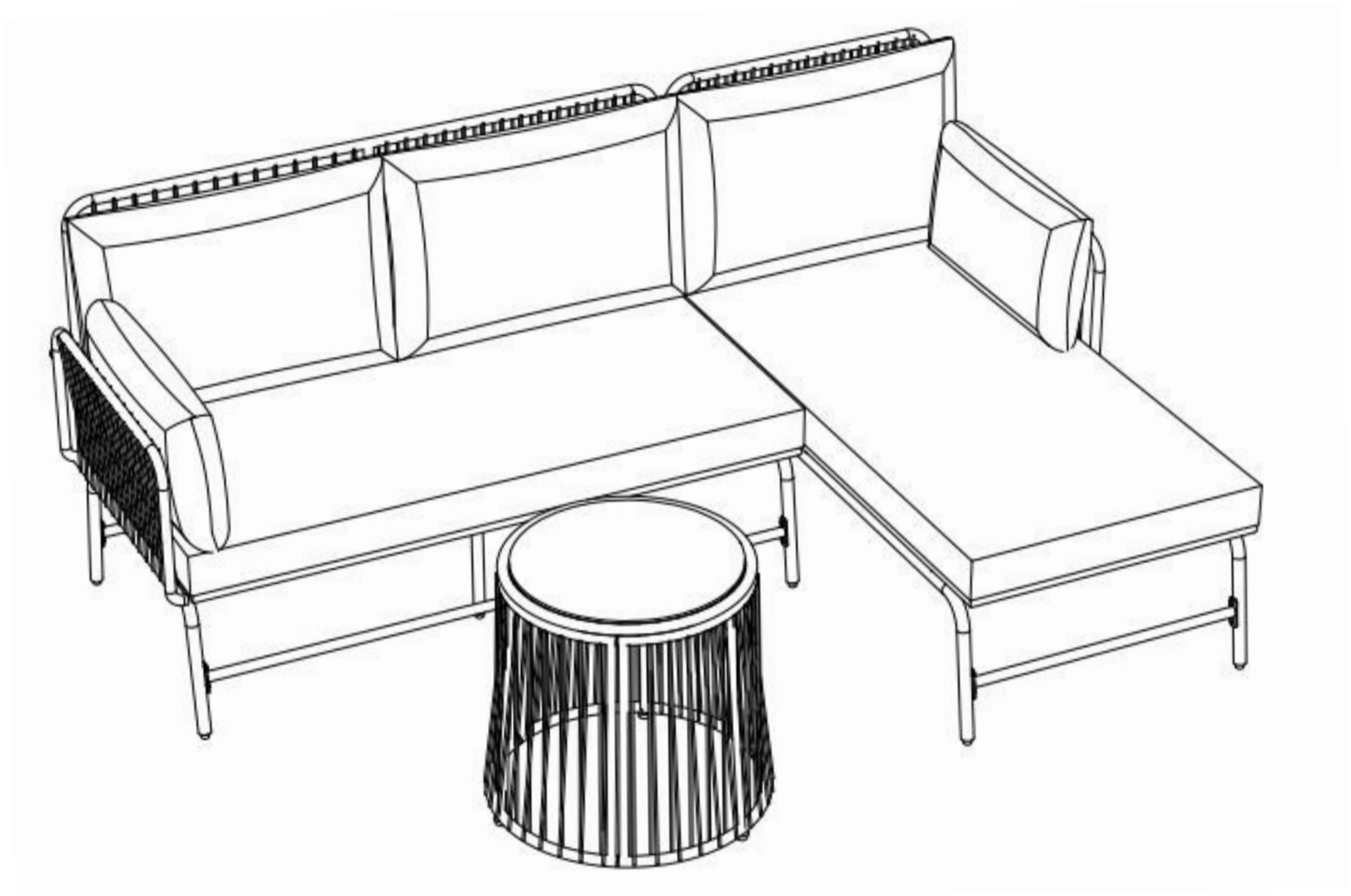

Set up The part from Step 16 & the Table finish Sofa Set.

STEP 21

C x1

F x1

3 x2

4 x2

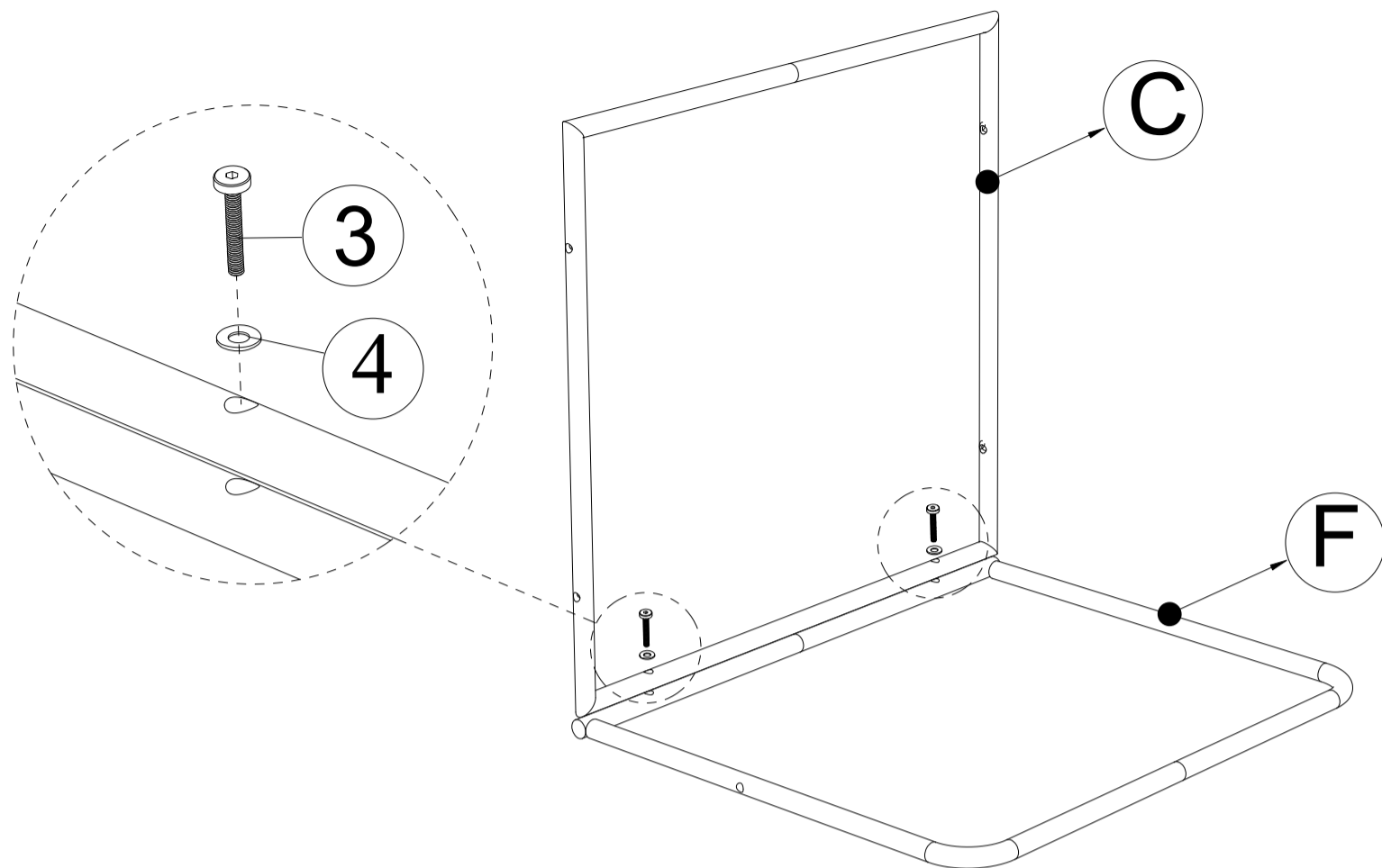
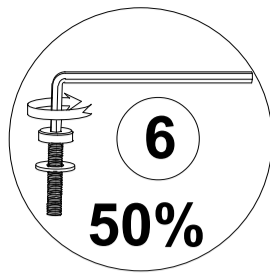

x2

Connect Seat Chair (C) & Back Chair (E), tighten Bolt (3) & Flat washer (4) with Allen Key (6)

STEP 22 with Allen Key (6)

G x1

H x1

3 x4

4 x4

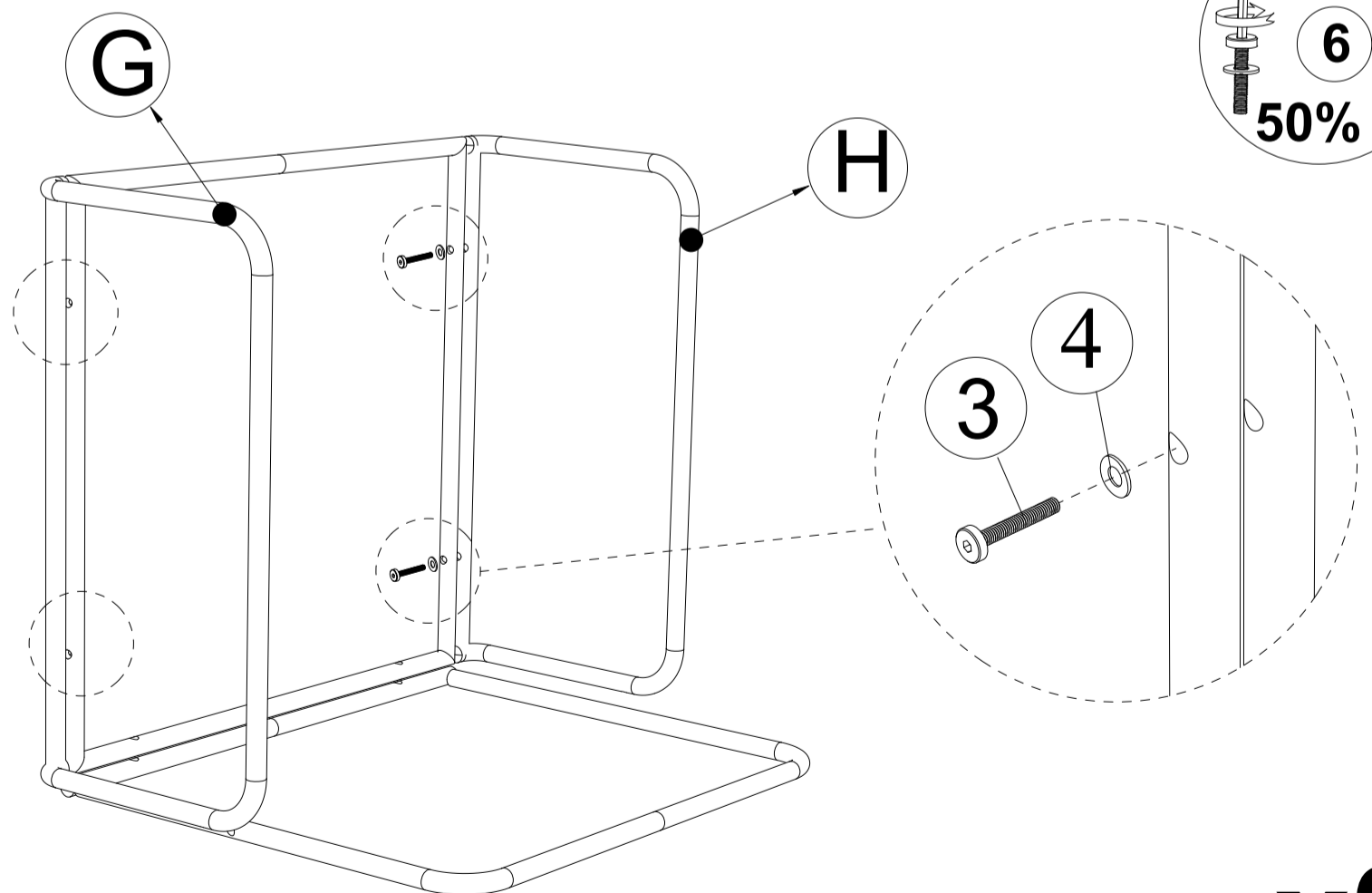
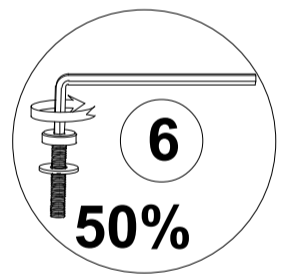

x2

Connect the part from step 21 & Right Arm (H) & Left Arm (G), tighten Bolt (3) & Flat washer (4) with Allen Key (6).

STEP 23

J x2

3 x4

4 x4

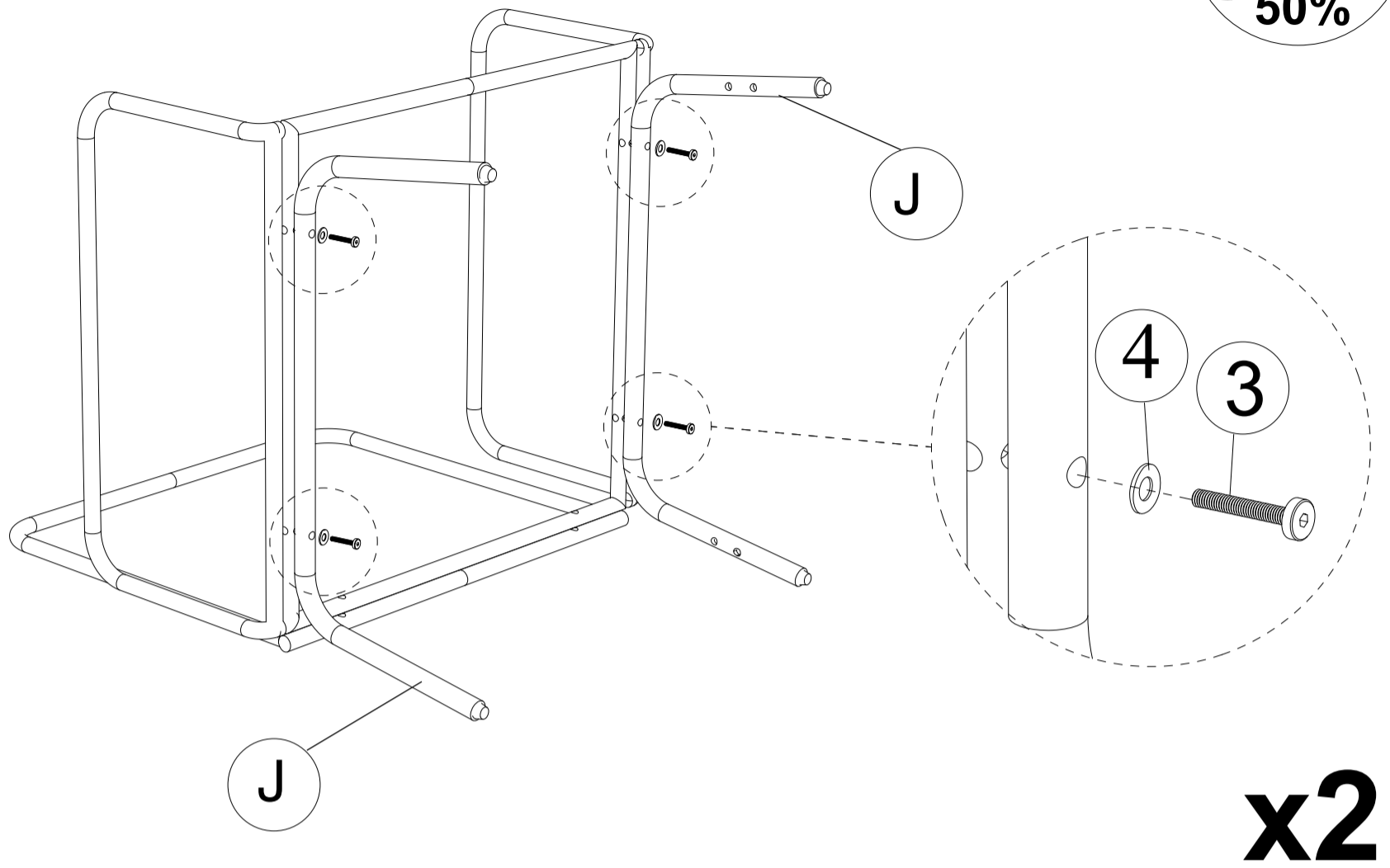
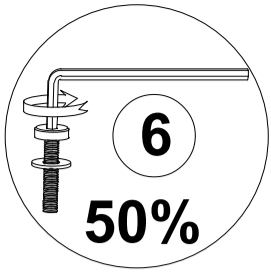

x2

Connect the part from step 22 & Short Leg (J), tighten Bolt (3) & Flat washer (4) with Allen Key (6)

STEP 24

M x2

1 x8

4 x8

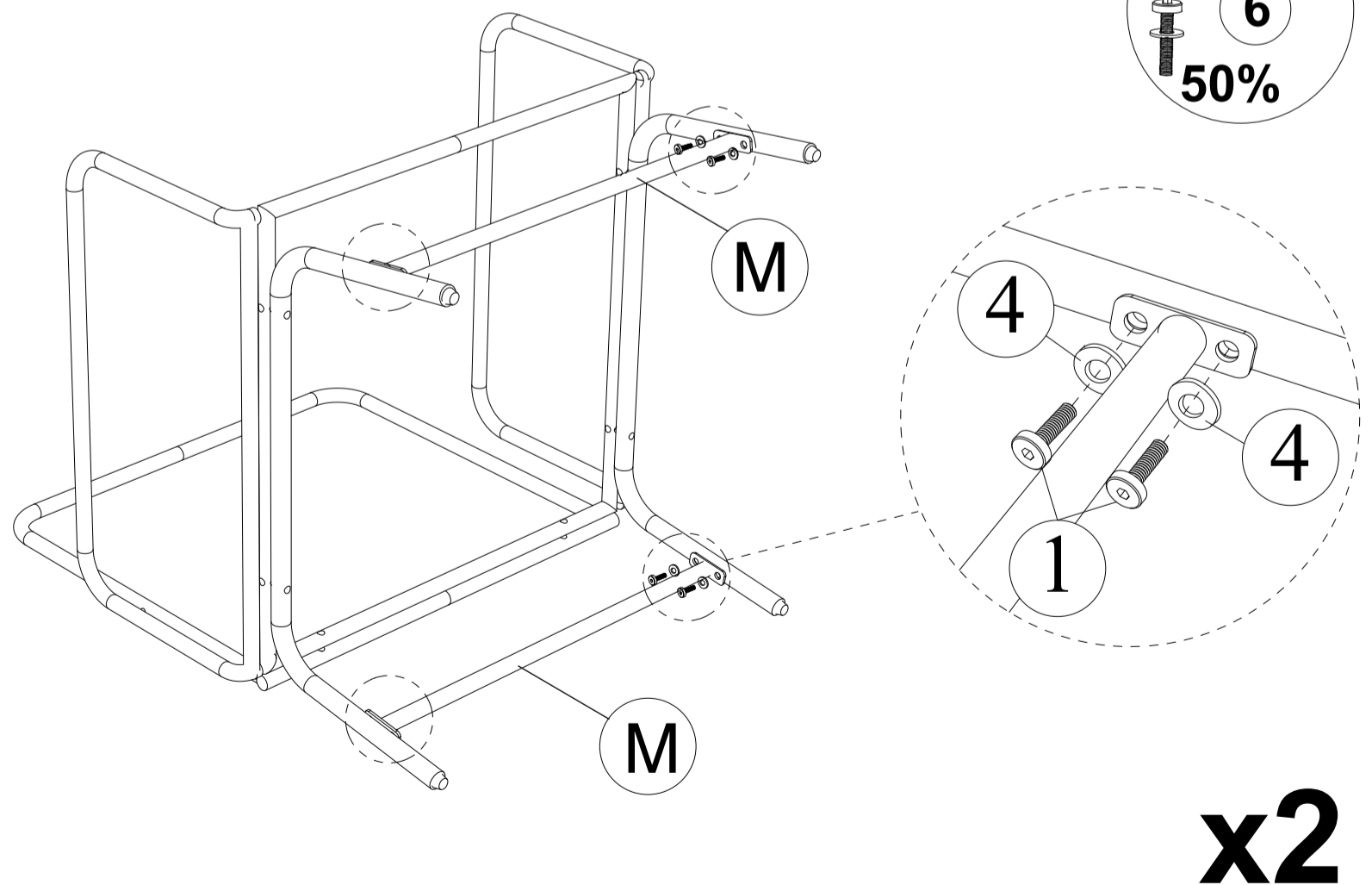
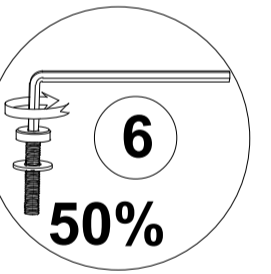

x2

Connect the part from step 23 & Short Collection 2 (M), tighten Bolt (1) & Flat washer (4) with Allen Key (6).

STEP 25

8 x2

1 x4

4 x4

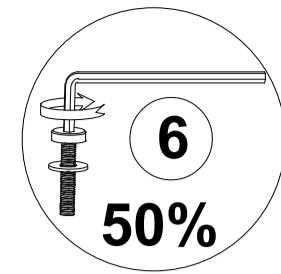
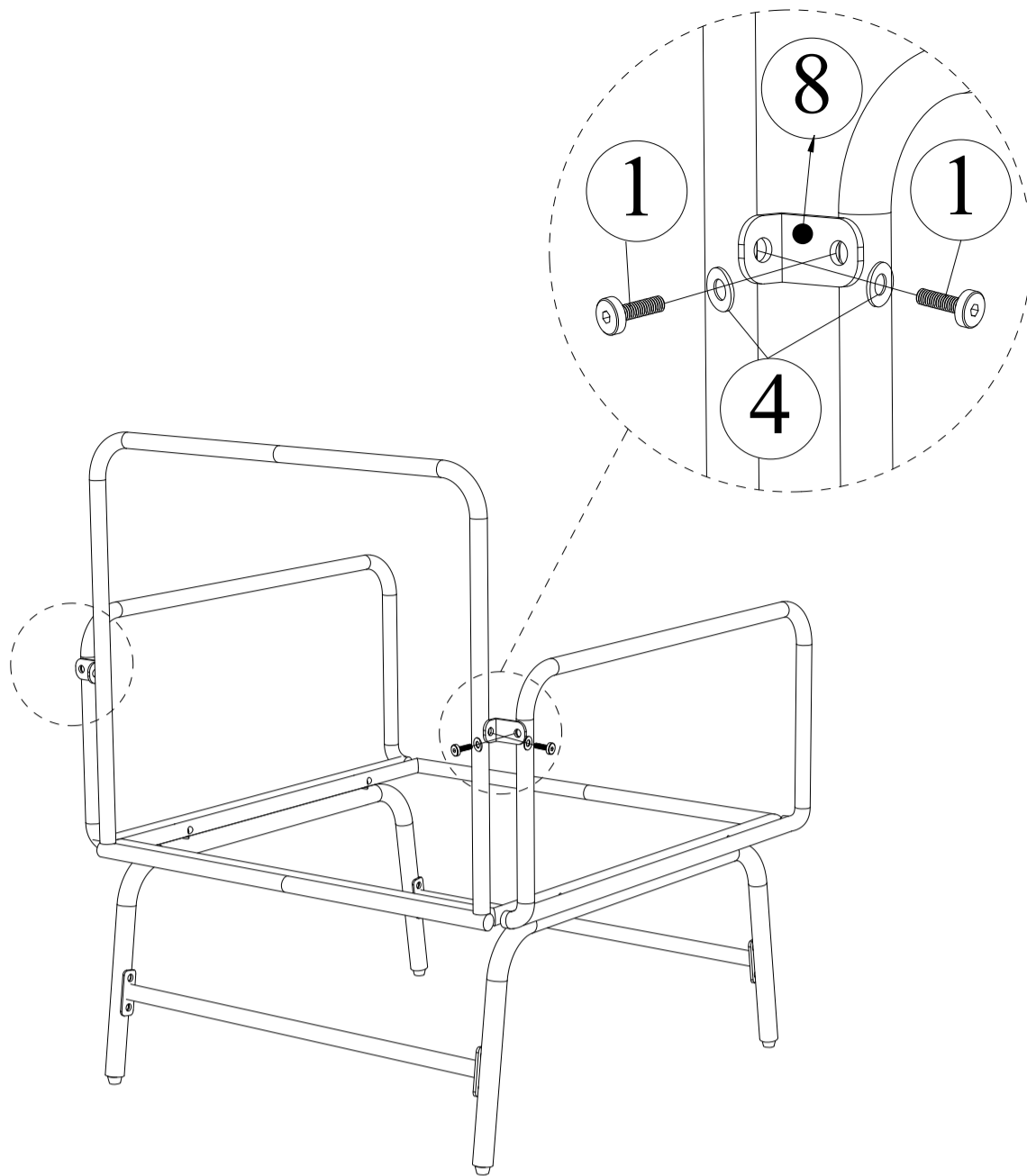

x2

Put The part from Step 24 upright & Connect Square Collection (8), tighten Bolt (1) & Flat Washer (4) with Allen Key (6).

STEP 26

P x1

S x1

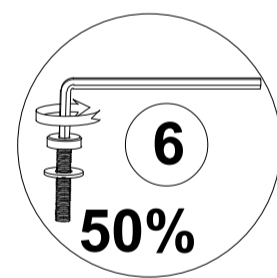
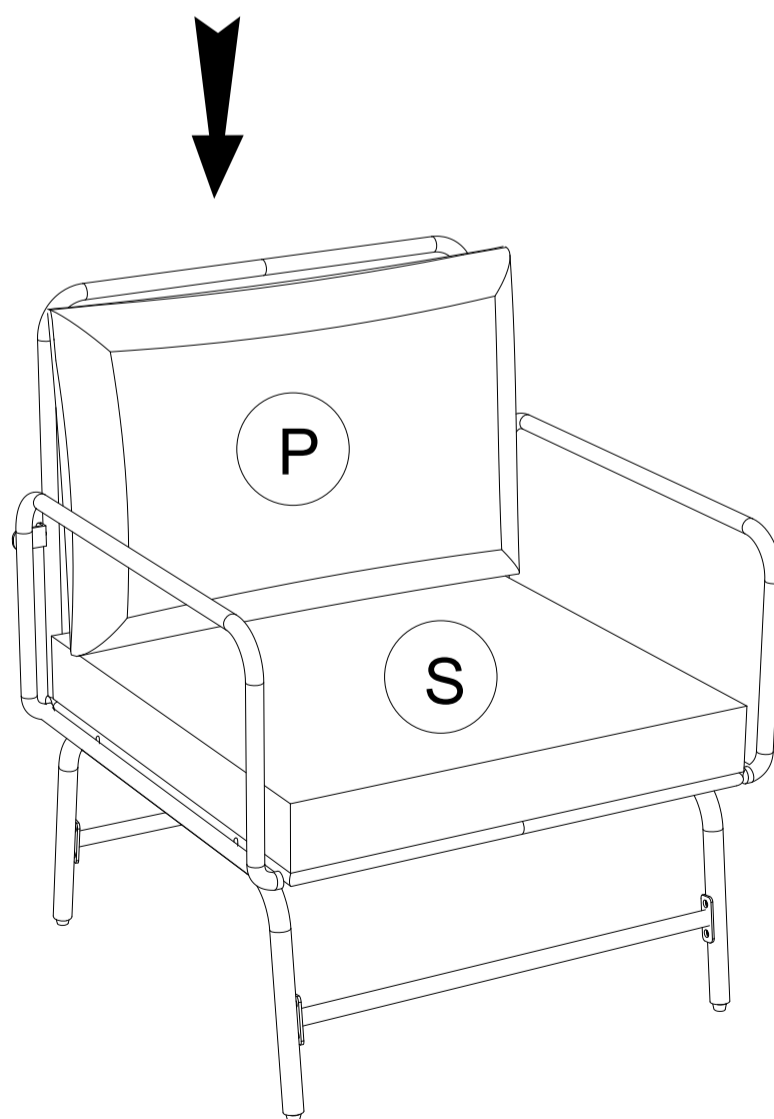

x2

Firmly, tighten Bolts with Allen Key (6) & Finish Chair Frame Set up the the Cushions (S)+(P)

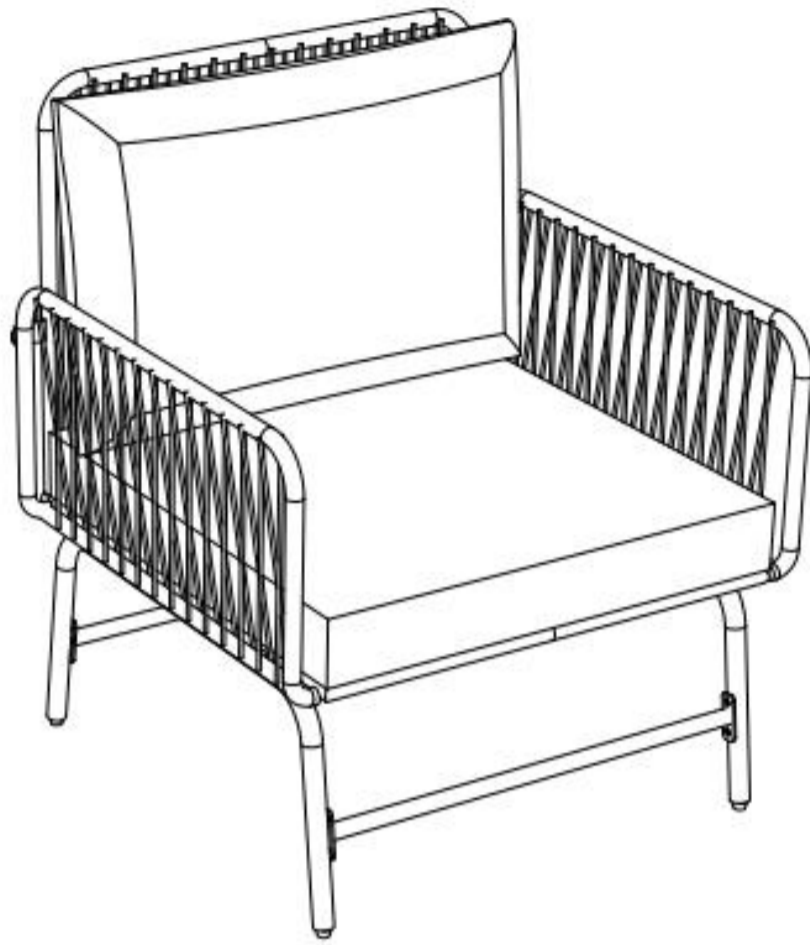

x2

Finish Chairs

STEP 27

V x1

Y x2

1 x4

4 x4

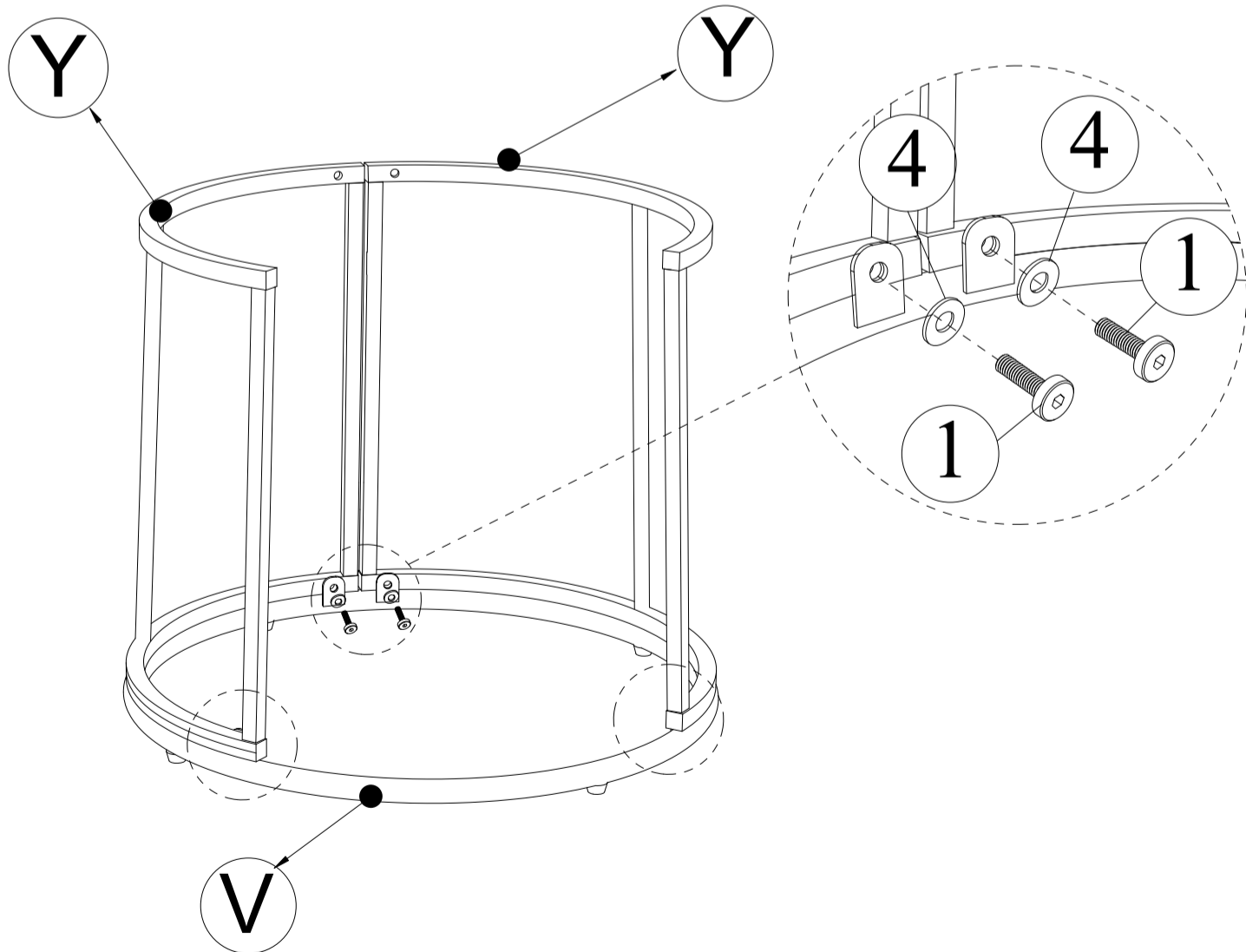

Connect Leg Big Table (Y) & Bottom Big Table (V), tighten Bolt (1) & Flat Washer (4) with Allen Key (6).

STEP 28

U x1

1 x4

4 x4

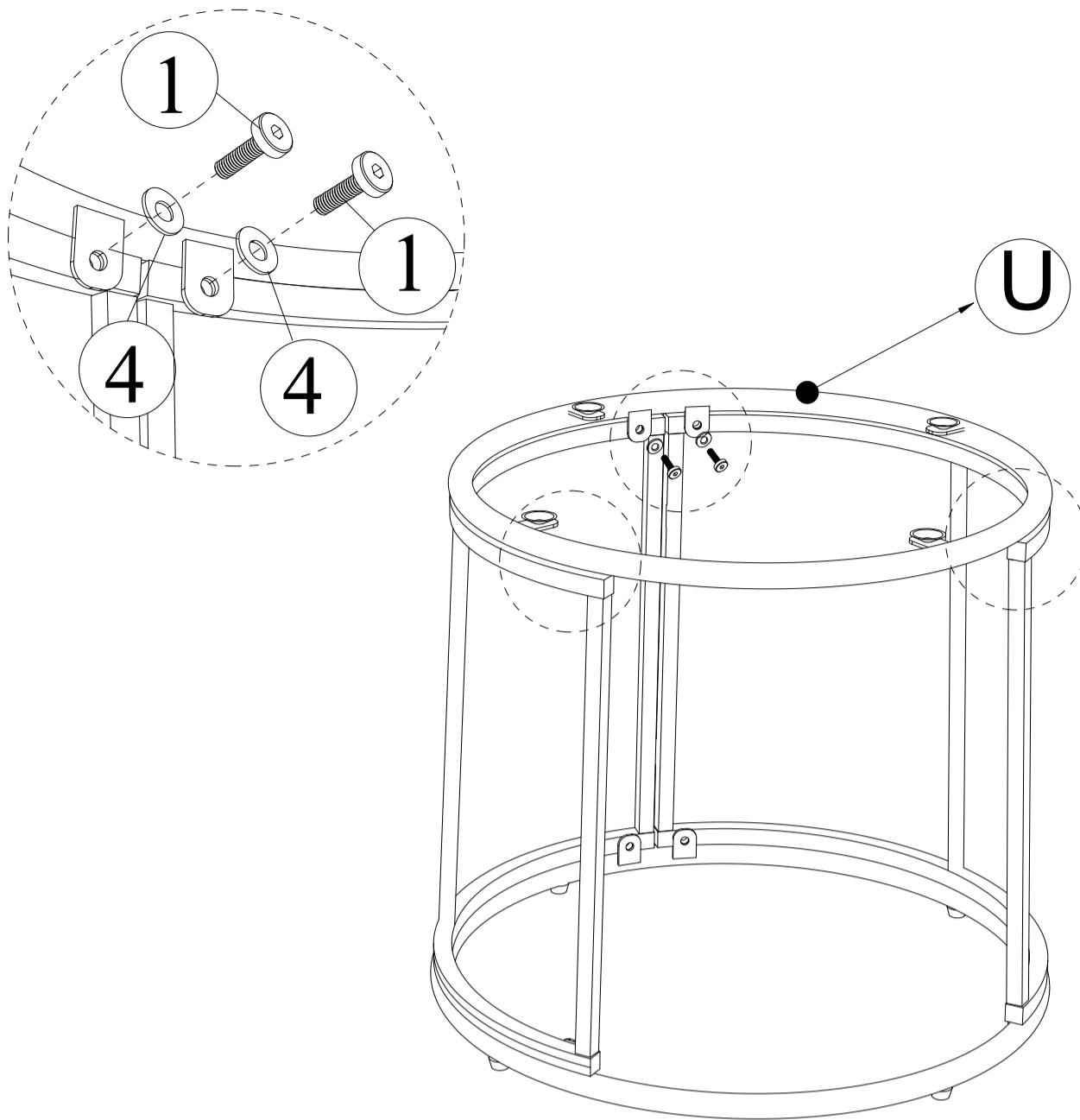

Connect the part from step 27 & Top Big Table (U), tighten Bolt (1) & Flat Washer (4) with Allen Key (6).

STEP 29

R x1

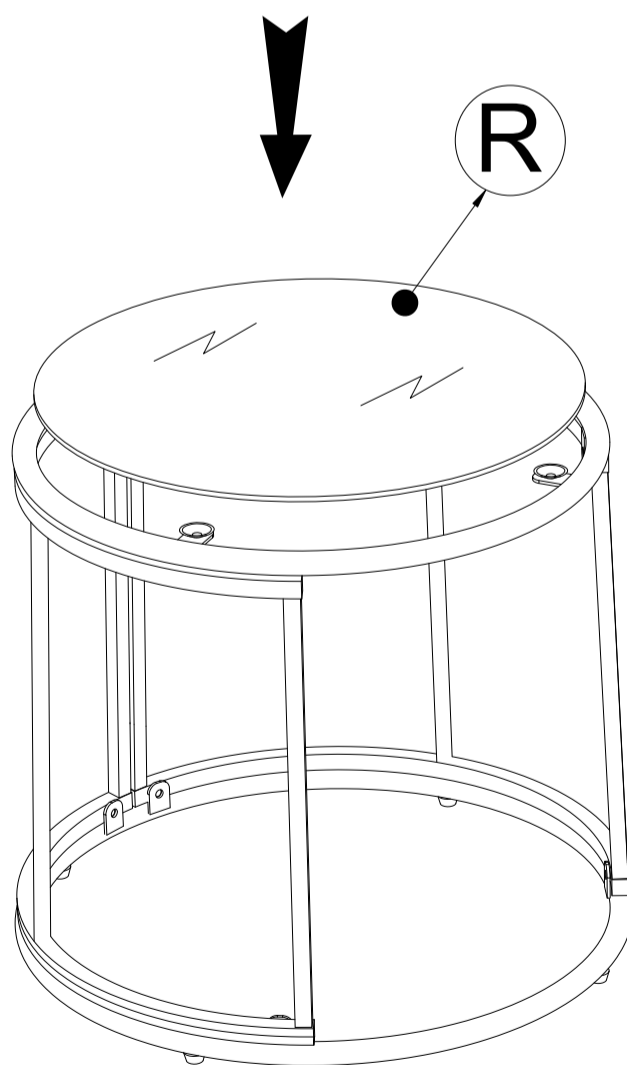

Firmly, tighten Bolts with Allen Key (6) Put the Big Glass Top (R) on the top frame

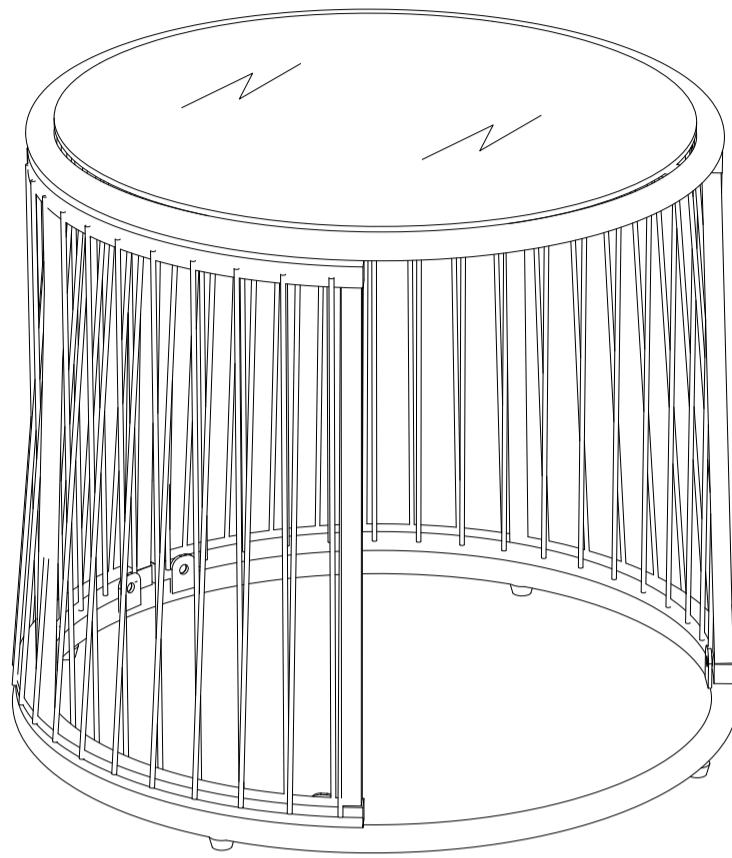

Finish Big Table

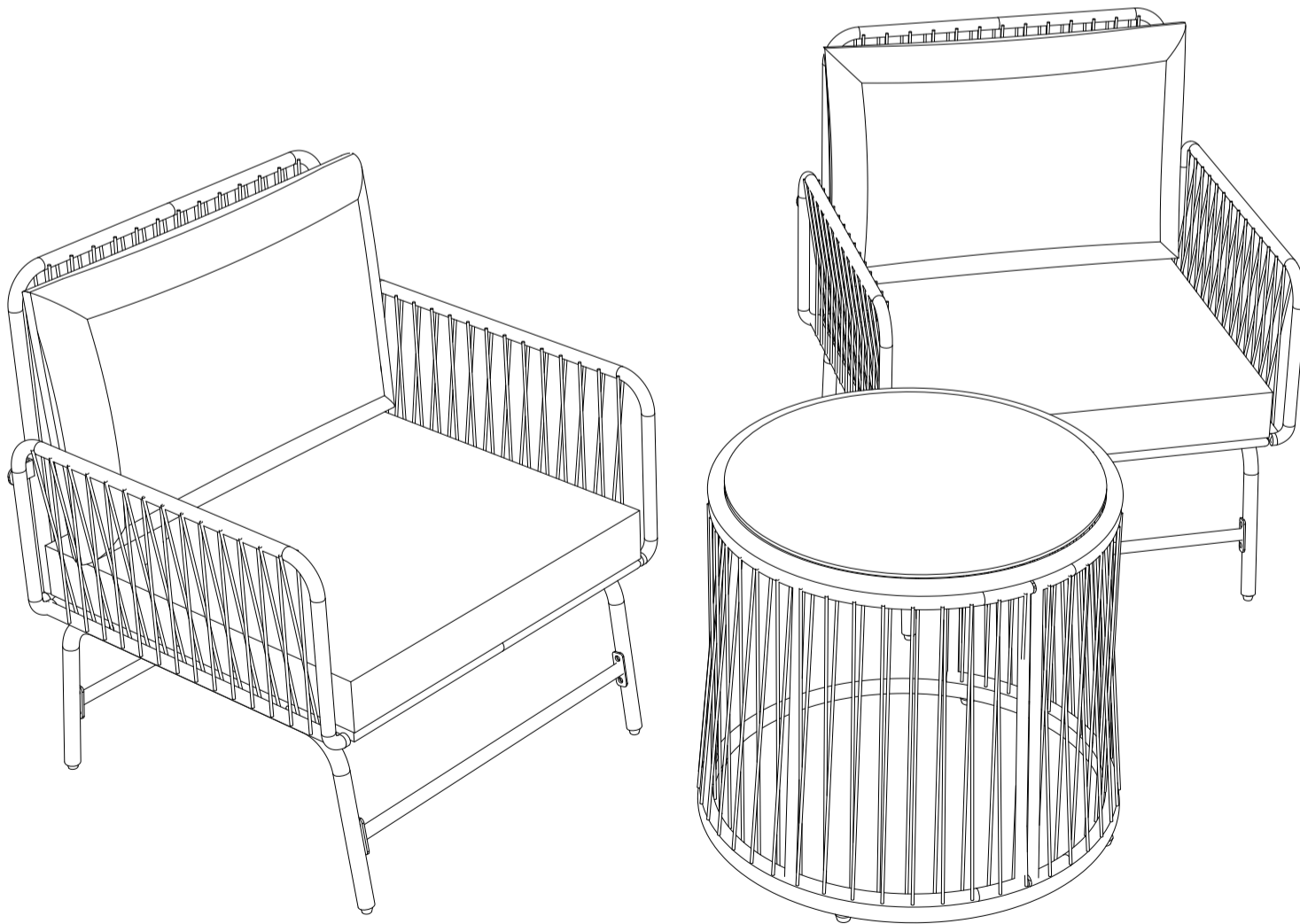

Set up Chair & the Big Table.

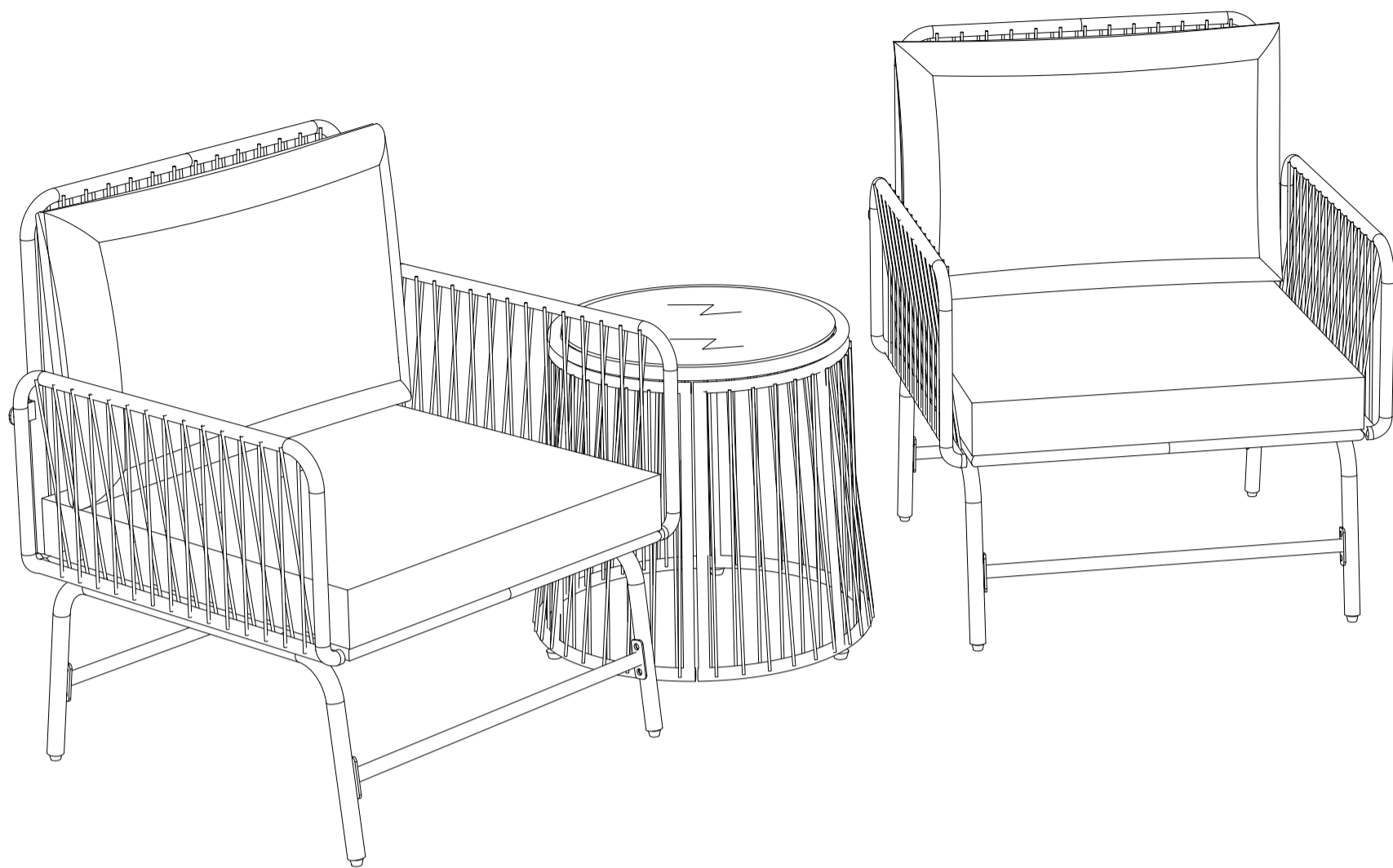

Set up Chair & the Small Table.

STEP 30

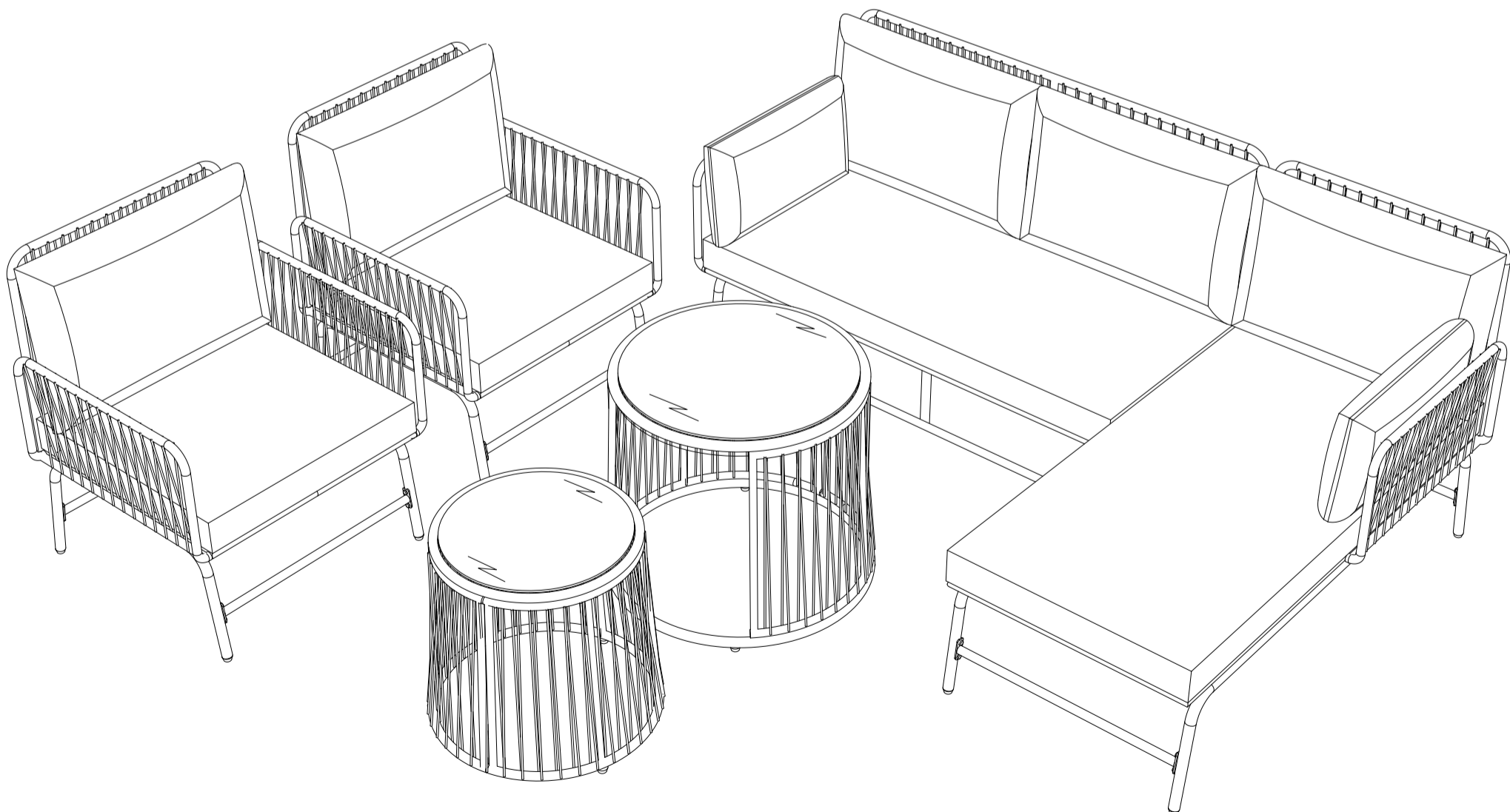

Set up Benchs, Chair & Small Table, Big Table.

INSTALLATIONSANWEISUNG

SOFABEZUG AUS SEIL

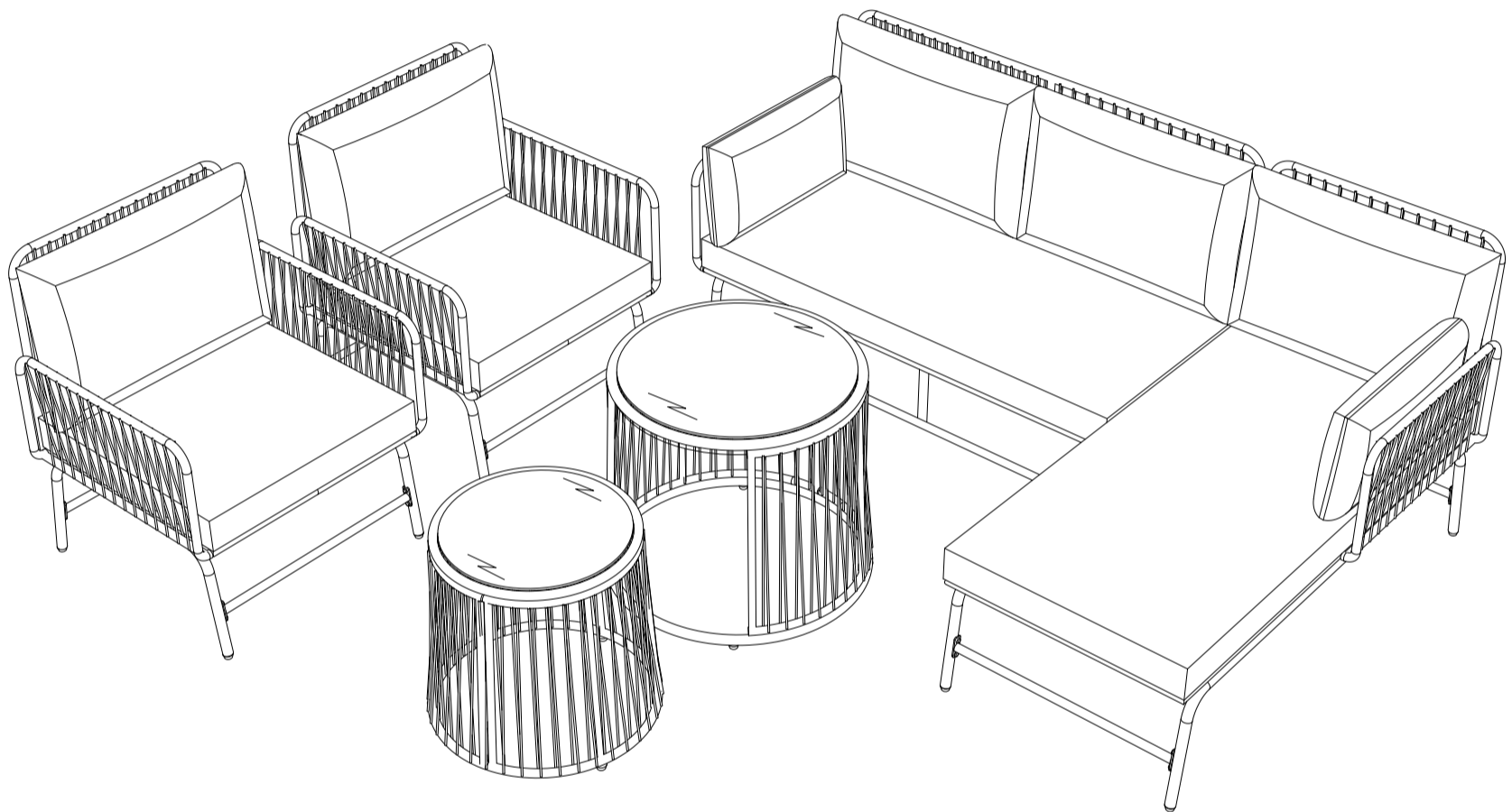

WF316572; WF316573 WF316574

Setzen Sie vor der Installation die Schrauben in die Löcher ein und ziehen Sie sie fest, aber ziehen Sie sie nicht zu 100 % an, 70 % bis 80 % reichen aus. Schließlich, nachdem alle Schrauben installiert sind, ziehen Sie alle Schrauben zu 100 % an. Wenn Sie auf diese Probleme stoßen Wenn beispielsweise die Löcher nicht ausgerichtet werden können oder einige Teile nicht installiert werden können, überprüfen Sie bitte, ob die Schrauben richtig verwendet werden, und passen Sie den festen Sitz der Schrauben an.

x1

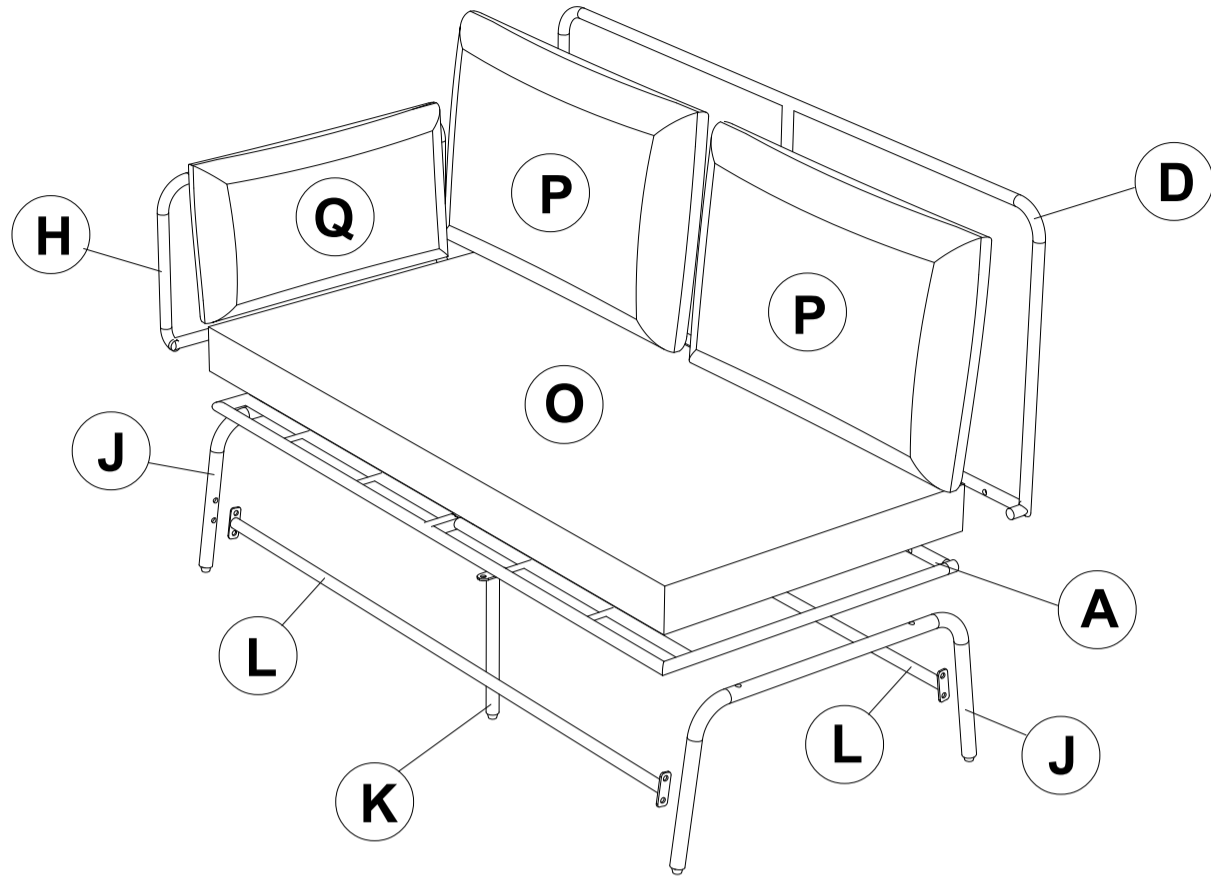

x1

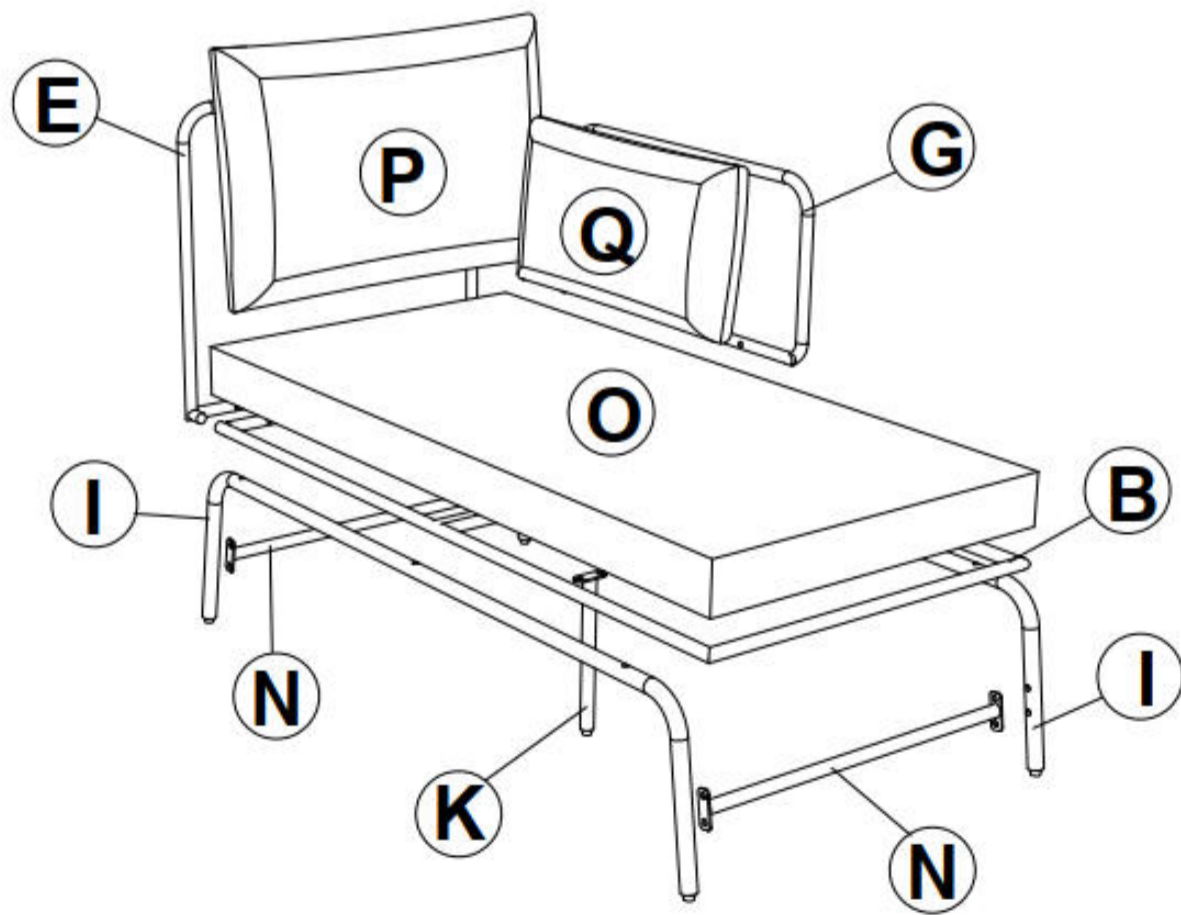

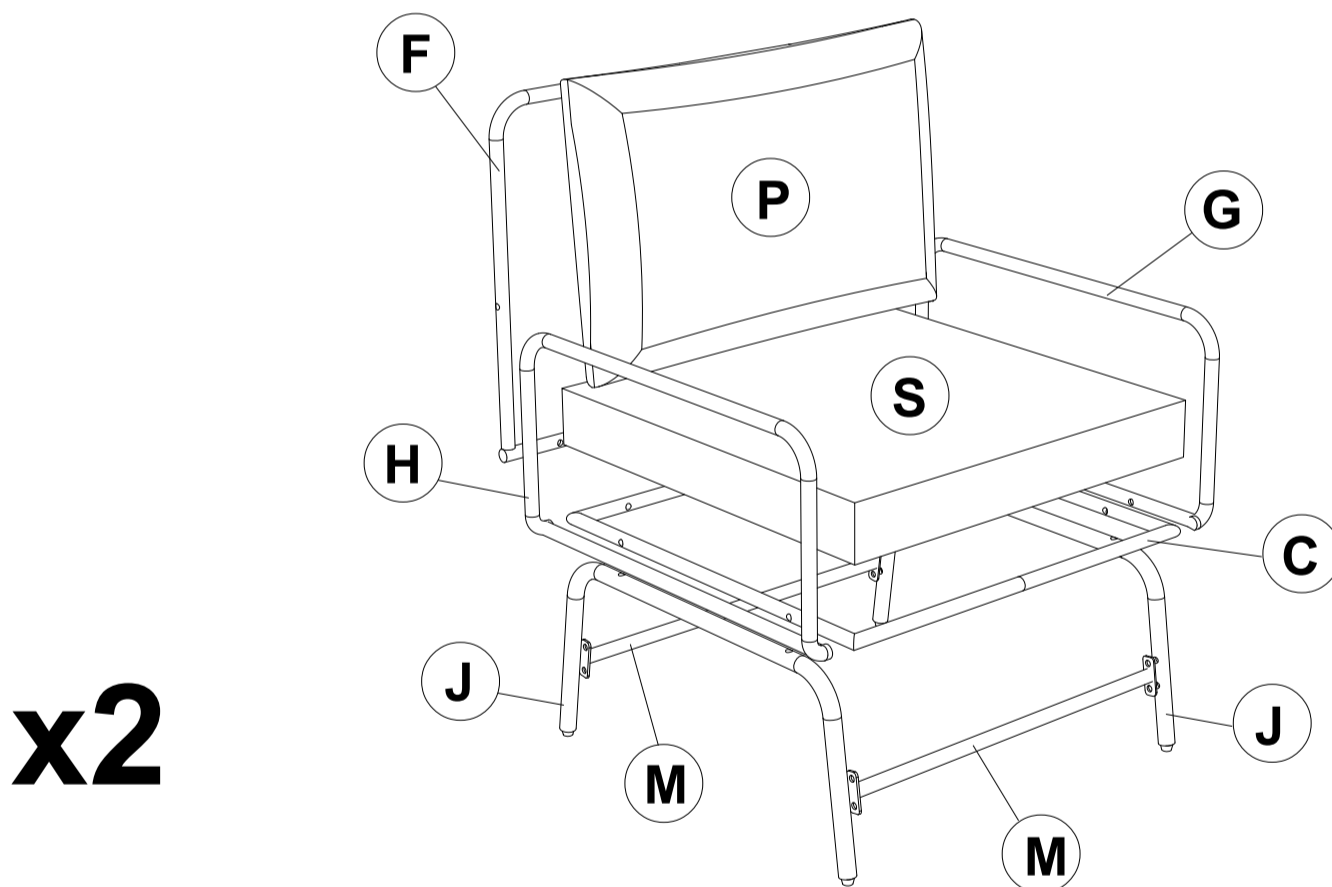
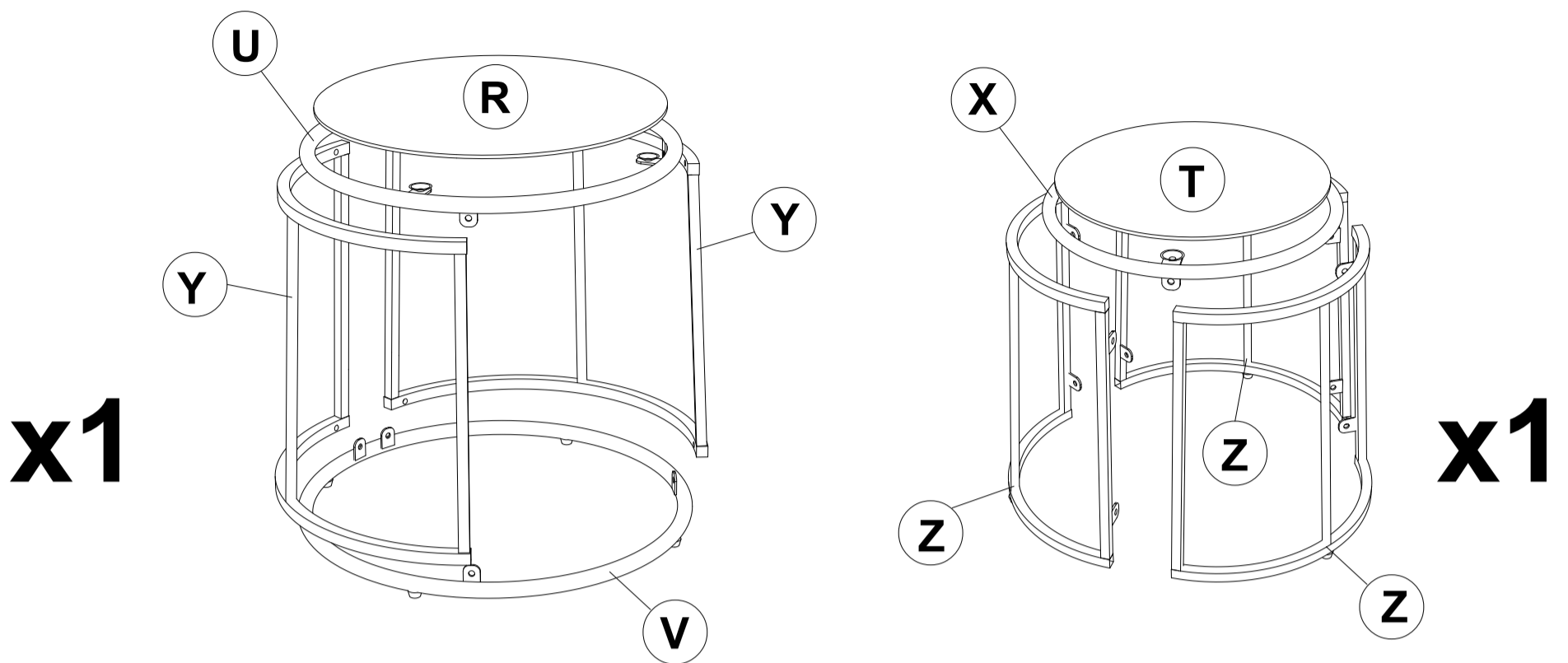



Beachten:

1. 50 % festziehen, bevor alle Schrauben befestigt werden. Anstelle einer elektrischen Bohrmaschine wird ein Inbusschlüssel empfohlen.
2. Stellen Sie den Gegenstand zum Ausrichten auf einen ebenen Untergrund und stellen Sie sicher, dass er stabil bleibt
3. Alle Schrauben mit Werkzeug nach und nach festziehen.
4. Wenn die Schrauben bei der Montage nicht mit den Löchern übereinstimmen, lösen Sie bitte alle. Drehen Sie die anderen Schrauben auf 50 % und setzen Sie den Montagevorgang fort.
5. Sollte der Artikel nicht stabil stehen, lösen Sie bitte alle Schrauben, stellen Sie ihn auf einen ebenen Untergrund und ziehen Sie alle Schrauben wieder fest.
6. Hinweis: Wenn eine oder mehrere Schrauben während der Montage vollständig angezogen werden, besteht die Möglichkeit, dass die anderen nicht mit den Löchern ausgerichtet sind. Darüber hinaus sind alle Löcher relativ größer ausgelegt, um mehr Platz für die Justierung der Schrauben zu bieten.

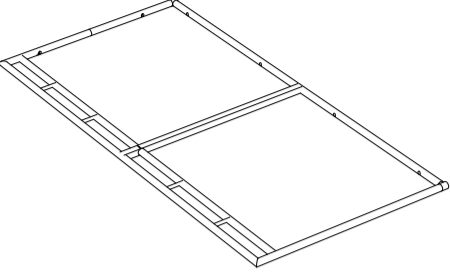
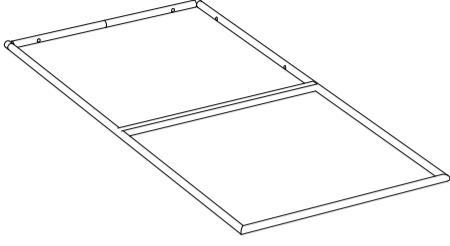
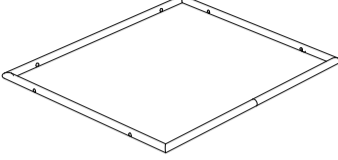
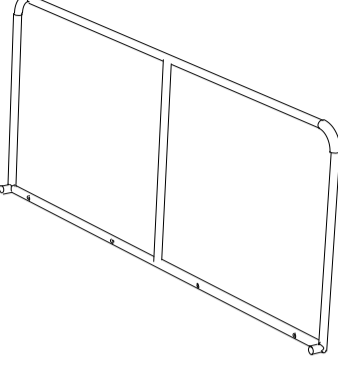
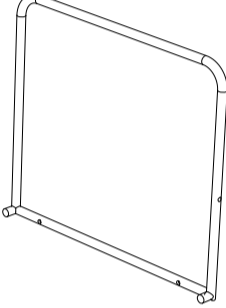
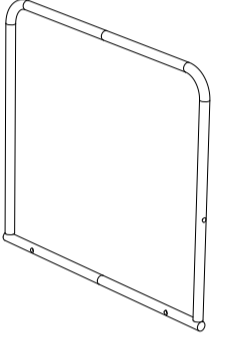
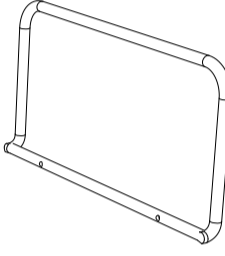
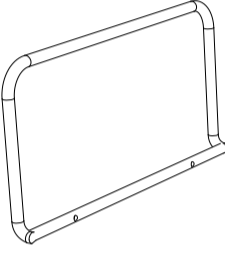
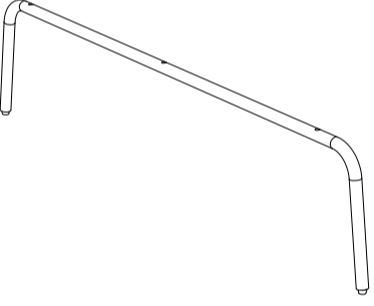
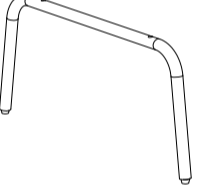
Teileliste :

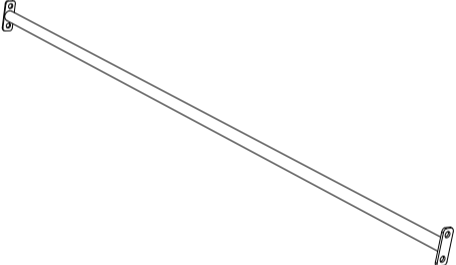
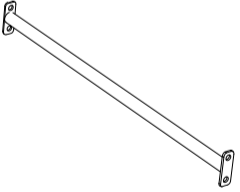
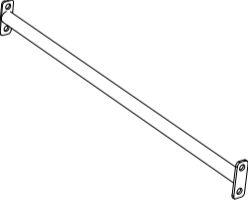
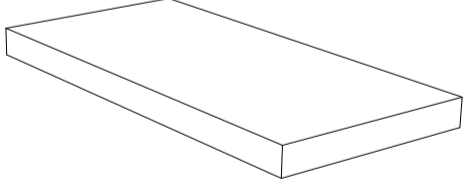
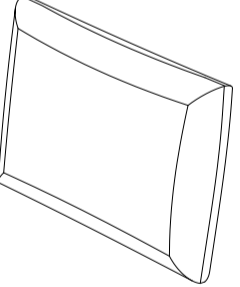
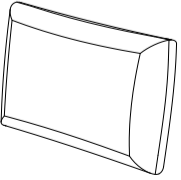
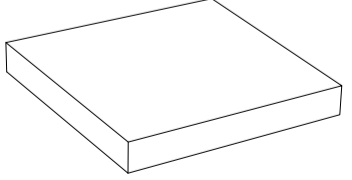
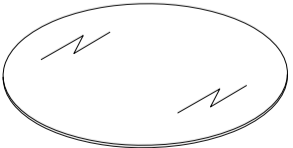
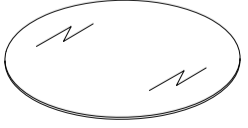
<p>A</p>  <p>Sitzbank 1 (1 Stück)</p>	<p>B</p>  <p>Sitzbank 2 (1 Stück)</p>	<p>C</p>  <p>Sitzstuhl (2 Stück)</p>	<p>D</p>  <p>Lange Rückbank(1Stück)</p>
<p>E</p>  <p>Kurze Rückbank (1 Stück)</p>	<p>F</p>  <p>Rückenstuhl (2 Stück)</p>	<p>G</p>  <p>Linker Arm (3 Stück)</p>	<p>H</p>  <p>Rechter Arm (3 Stück)</p>
<p>I</p>  <p>Langes Bein (2 Stück)</p>	<p>J</p>  <p>Kurzes Bein (6 Stück)</p>	<p>K</p>  <p>Stützbein (2 Stück)</p>	<p>L</p>  <p>Lange Verbindung (2 Stück)</p>
<p>N</p>  <p>Kurze Kollektion 1 (2 Stück)</p>	<p>M</p>  <p>Kurze Kollektion 2 (4 Stück)</p>	<p>O</p>  <p>Sitzbankkissen (2 Stück)</p>	<p>P</p>  <p>Rückenkissen (5 Stück)</p>
<p>Q</p>  <p>Armkissen (2 Stück)</p>	<p>S</p>  <p>Sitzstuhlkissen (2 Stück)</p>	<p>R</p>  <p>Große Glasplatte (1 Stück)</p>	<p>T</p>  <p>Kleine Glasplatte (1 Stück)</p>

Teileliste :

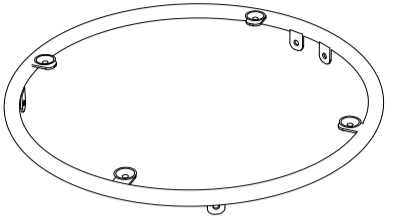
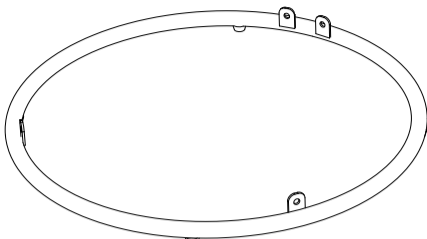
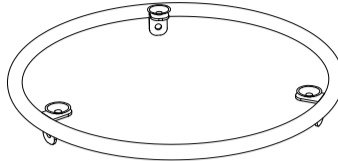
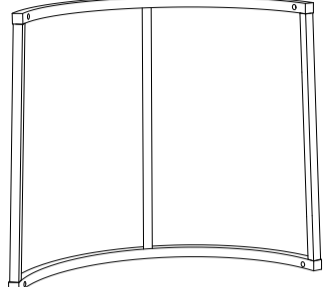
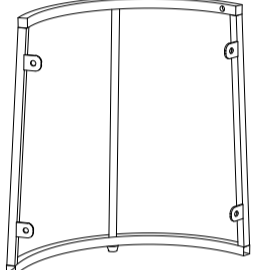
<p>U</p>  <p>Oberer großer Tisch (1 Stück)</p>	<p>V</p>  <p>Unterer großer Tisch (1 Stück)</p>	<p>X</p>  <p>Oberer kleiner Tisch (1 Stück)</p>	<p>Y</p>  <p>Bein großer Tisch (2 Stück)</p>
<p>Z</p>  <p>Kleiner Beintisch (3 Stück)</p>			

Hardware :

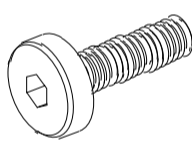
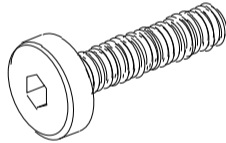
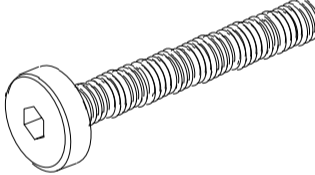
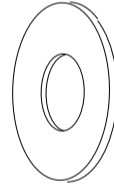
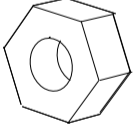
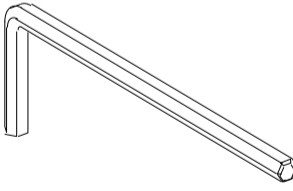
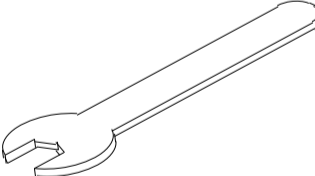
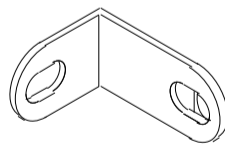
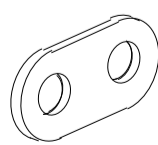
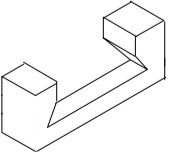
<p>1</p>  <p>Extra (6 Stück) Schraube M6x15mm (63 Stück)</p>	<p>2</p>  <p>Extra (1 Stück) Schraube M6x20 (6 Stück)</p>	<p>3</p>  <p>Extra (4 Stück) Schraube M6x40 (40 Stück)</p>	<p>4</p>  <p>Extra (6 Stück) U-Scheibe M6 (115 Stück)</p>
<p>5</p>  <p>Extra (1 Stück) Mutter M6 (6 Stück)</p>	<p>6</p>  <p>Allen Schlüssel (2 Stück)</p>	<p>7</p>  <p>Schlüssel (1 Stück)</p>	<p>8</p>  <p>Quadratische Kollektion (6 Stück)</p>
<p>9</p>  <p>Flache Kollektion (2 Stück)</p>	<p>10</p>  <p>U-Sharp-Kollektion (1 Stück)</p>		

Hardware: WF316572

Diese Hardware wird für WF316572
und WF316573 verwendet

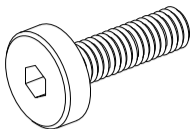
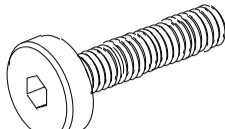
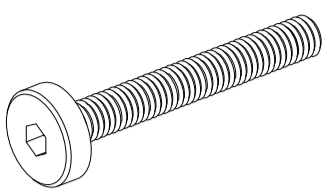
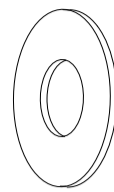
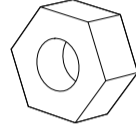
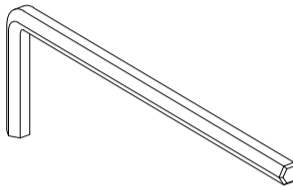
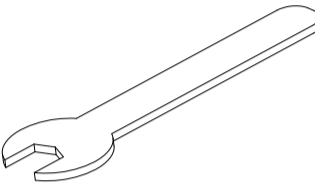
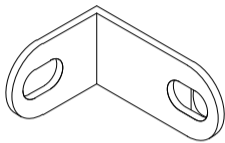
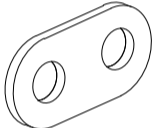
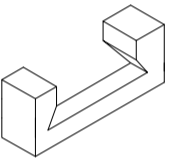
<p>1</p>  <p>Extra (3 Stück) Schraube M6x15mm (31 Stück)</p>	<p>2</p>  <p>Extra (1 Stück) Schraube M6x20 (6 Stück)</p>	<p>3</p>  <p>Extra (2 Stück) Schraube M6x40 (20 Stück)</p>	<p>4</p>  <p>Extra (3 Stück) U-Scheibe M6 (63 Stück)</p>
<p>5</p>  <p>Extra (1 Stück) Mutter M6 (6 Stück)</p>	<p>6</p>  <p>Allen Schlüssel (1 Stück)</p>	<p>7</p>  <p>Schlüssel (1 Stück)</p>	<p>8</p>  <p>Quadratische Kollektion (2 Stück)</p>
<p>9</p>  <p>Flache Kollektion (2 Stück)</p>	<p>10</p>  <p>U-Sharp-Kollektion (1 Stück)</p>		

Hardware: WF316574

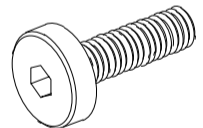
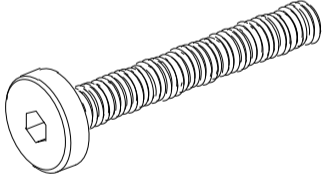
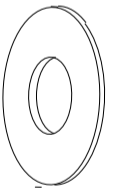
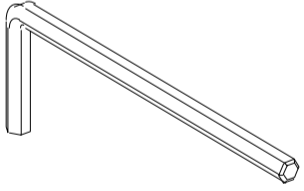
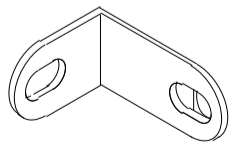
<p>1</p>  <p>Extra (3 Stück) Schraube M6x15mm (32 Stück)</p>	<p>3</p>  <p>Extra (2 Stück) Schraube M6x40 (20 Stück)</p>	<p>4</p>  <p>Extra (3 Stück) U-Scheibe M6 (52 Stück)</p>	<p>6</p>  <p>Allen Schlüssel (1 Stück)</p>
<p>8</p>  <p>Quadratische Kollektion (4 Stück)</p>			

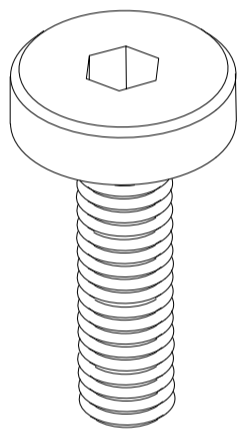

**SCHRAUBE
M6x15 MM**

1

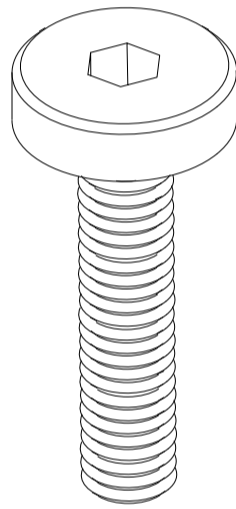

**SCHRAUBE
M6x20 MM**

2

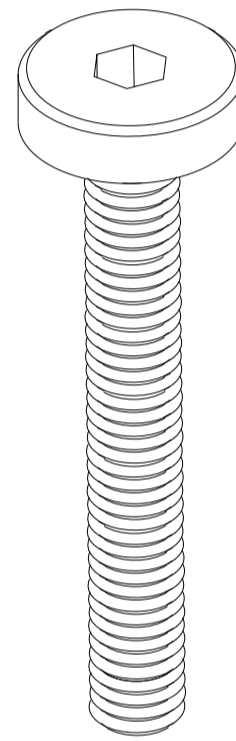

**SCHRAUBE
M6x40 MM**

3

Bitte beachten Sie, dass die Formen der Schrauben 1 und 2 und 3 ähnlich sind.
Bitte installieren Sie entsprechend der Anleitung und unterscheiden Sie sie!

KARTONINHALT:

WF316572

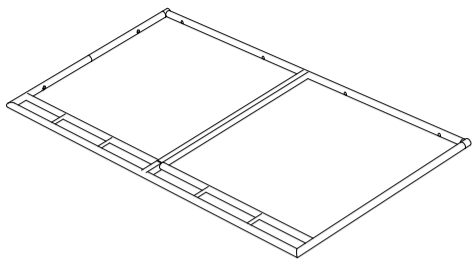

A x1

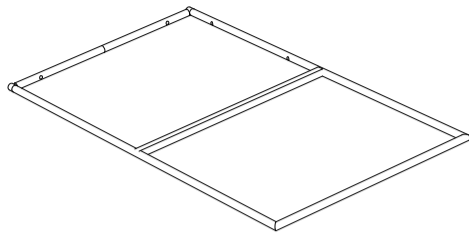

B x1

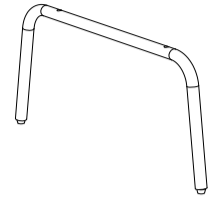

J x2

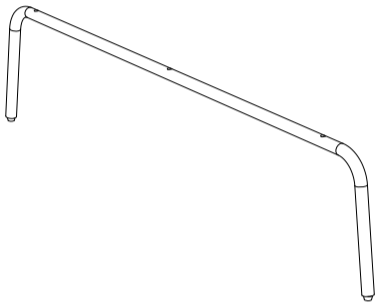

I x2

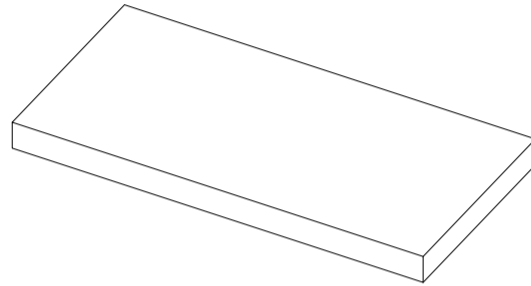

O x2

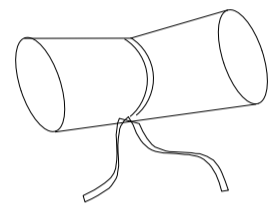

Hardware

WF316573

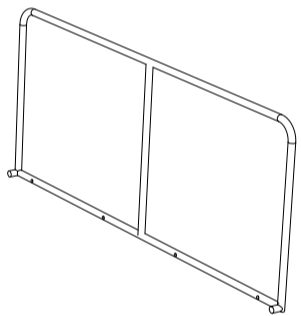

D x1

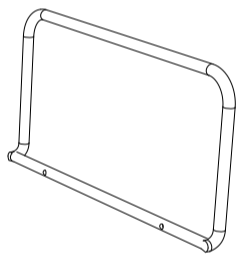

G x1

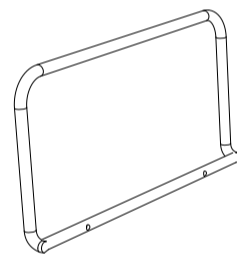

H x1

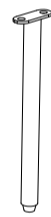

K x2

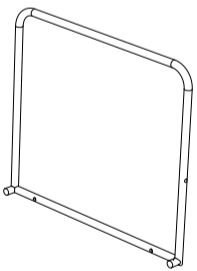

E x1

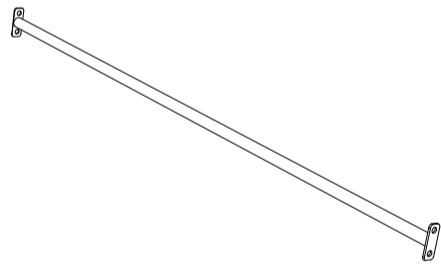

L x2

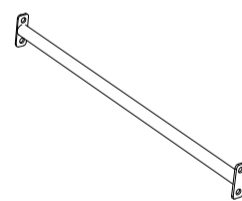

N x2

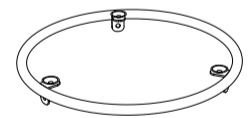

X x1

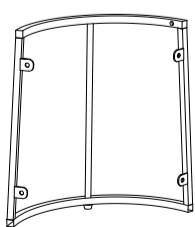

Z x3

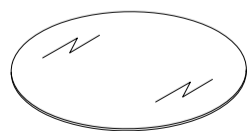

T x1

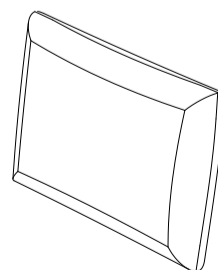

P x3

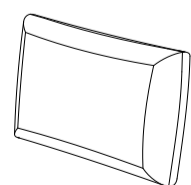

Q x2

KARTONINHALT:

WF316574

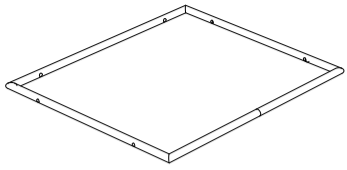

C x2

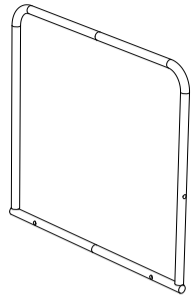

F x2

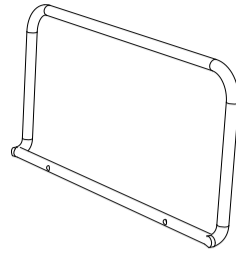

G x2

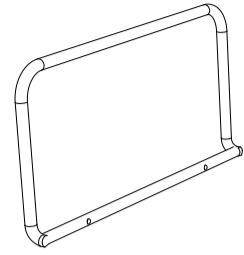

H x2



J x4

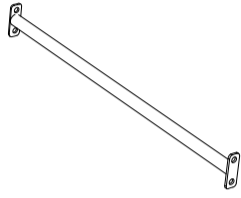

M x4

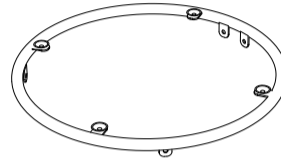

U x1

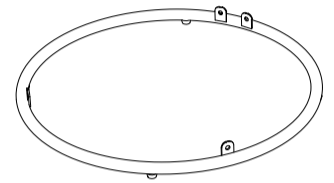

V x1

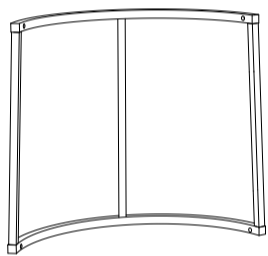

Y x2

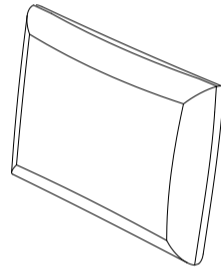

P x2



R x1

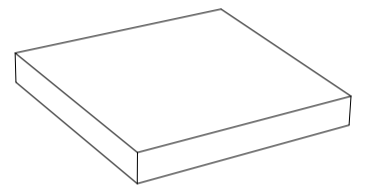

S x2

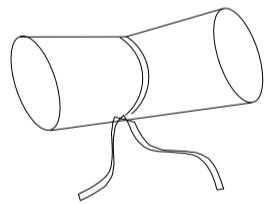

Hardware

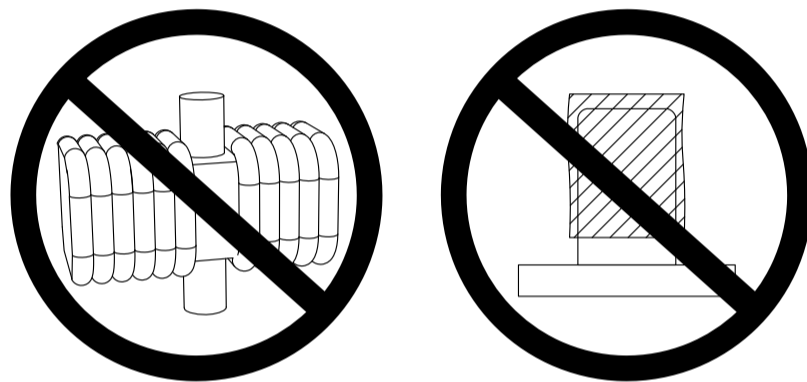

**BITTE ENTFERNEN SIE VOR DEM ZUSAMMEMBAU DIE
ROHRSTIFTE ROHRSTIFTE UND SCHUTZTEILE AUS
DER TEILELISTE**

SCHRITT 1

A x1

D x1

3 x4

4 x4

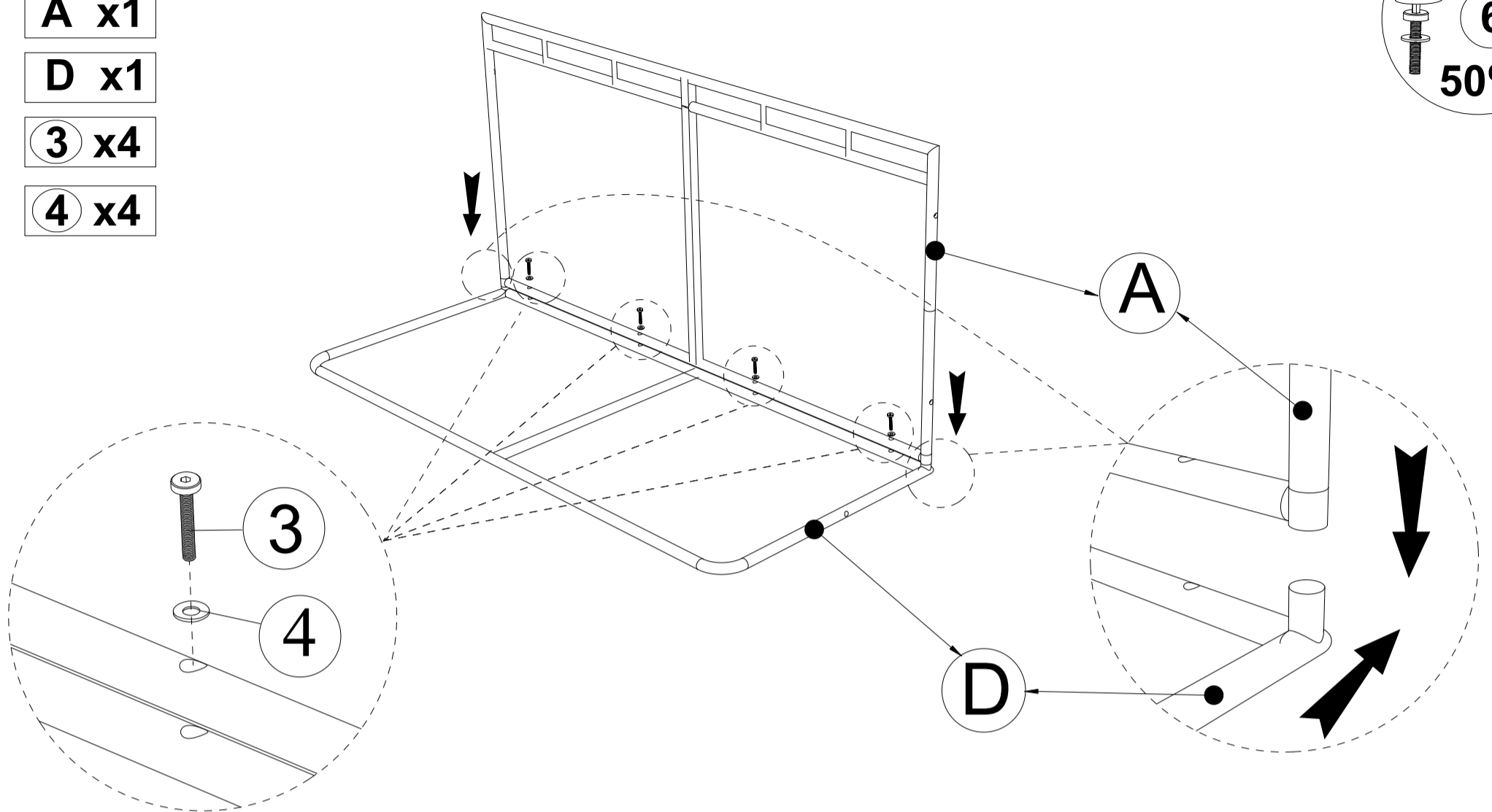
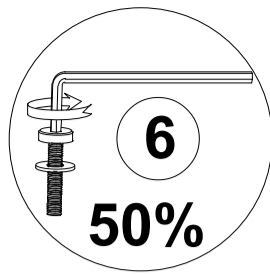

Push & Connect-Sitzbank 1 (A) & Lange Rückbank(D), Schraube festziehen (3) & Unterlegscheibe (4) mit Inbusschlüssel (6).

SCHRITT 2

H x1

3 x2

4 x2

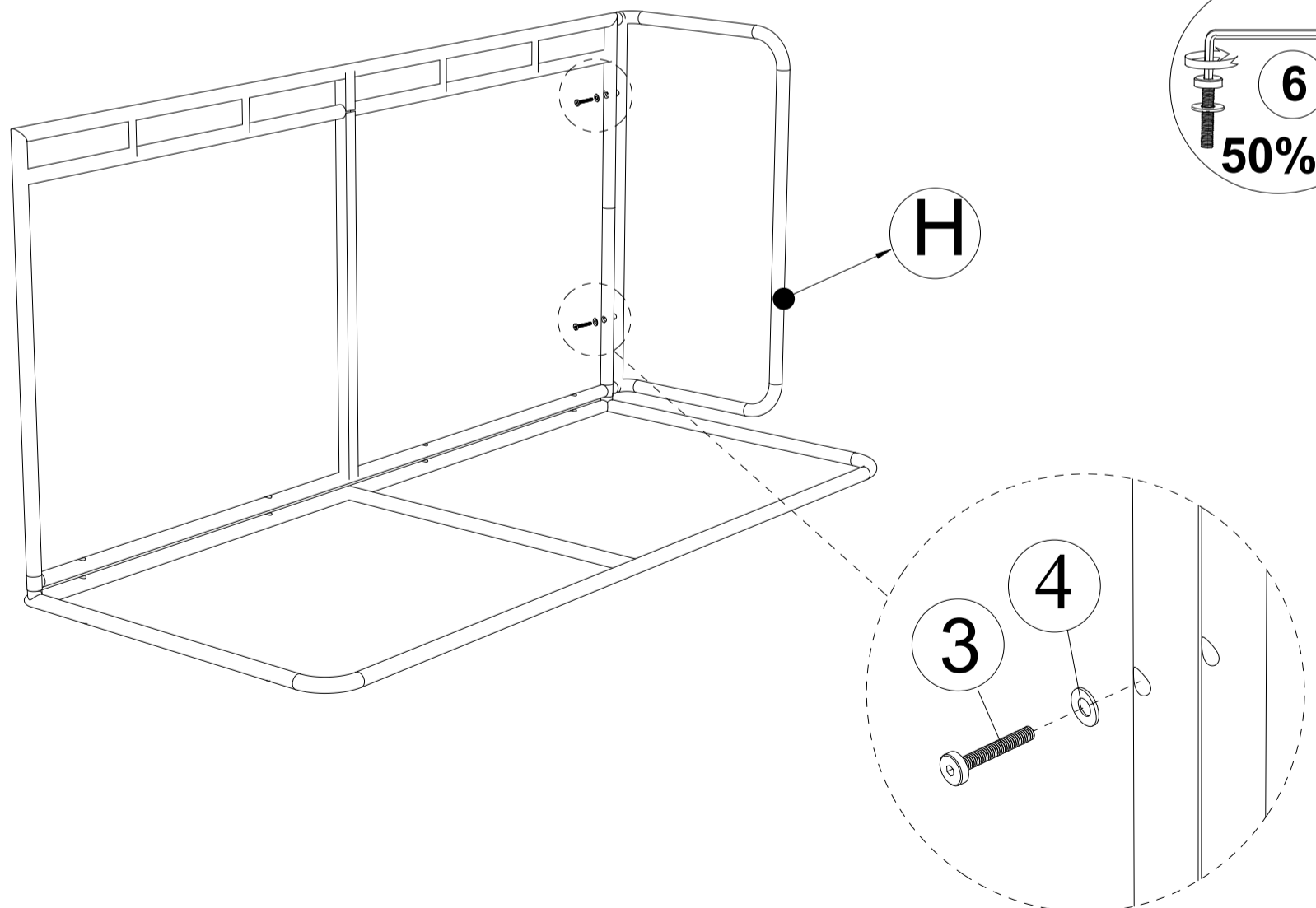
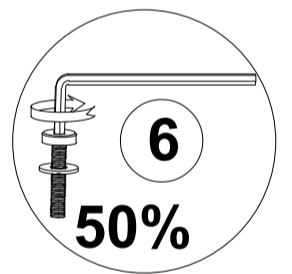

Verbinden Sie das Teil aus Schritt 1 & Rechter Arm (H), Schraube festziehen (3) & Flache Unterlegscheibe (4) mit Inbusschlüssel (6).

SCHRITT 3

J x2

3 x4

4 x4

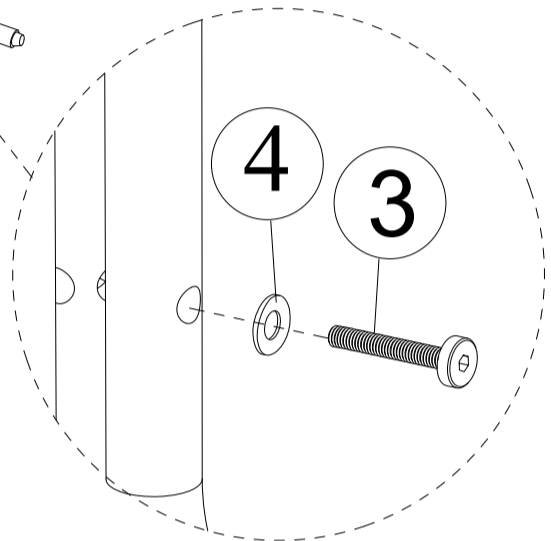
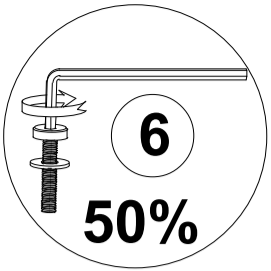
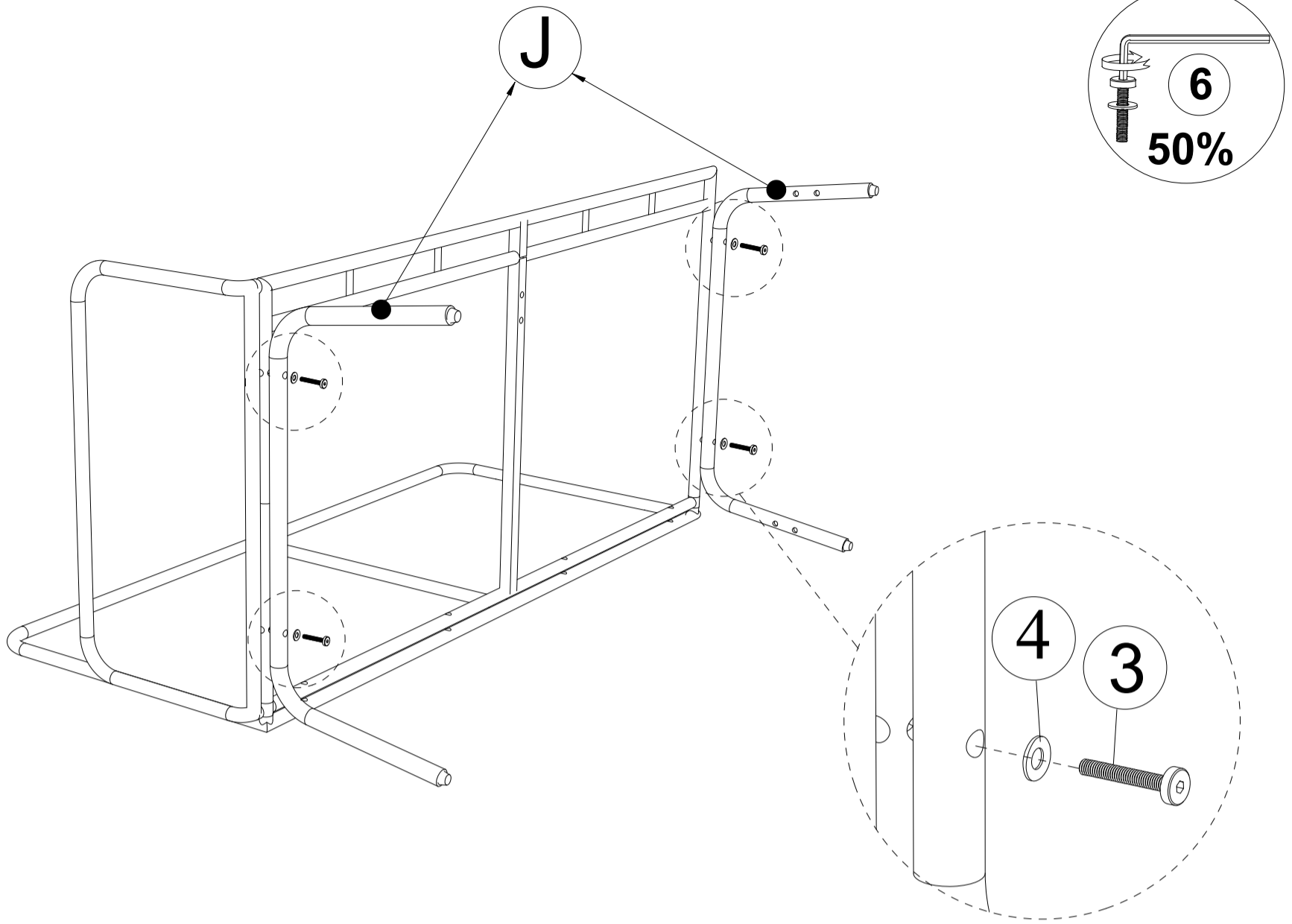

Verbinden Sie das Teil aus Schritt 2 & Kurzes Bein (J), Schraube festziehen (3) Unterlegscheibe (4) mit Inbusschlüssel (6).

SCHRITT 4

L x2

1 x8

4 x8

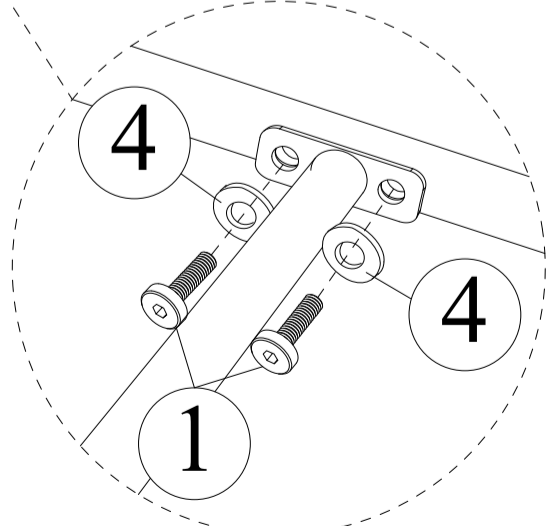
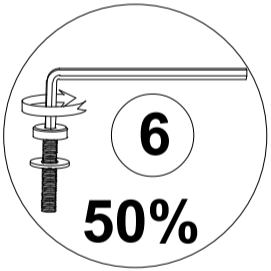
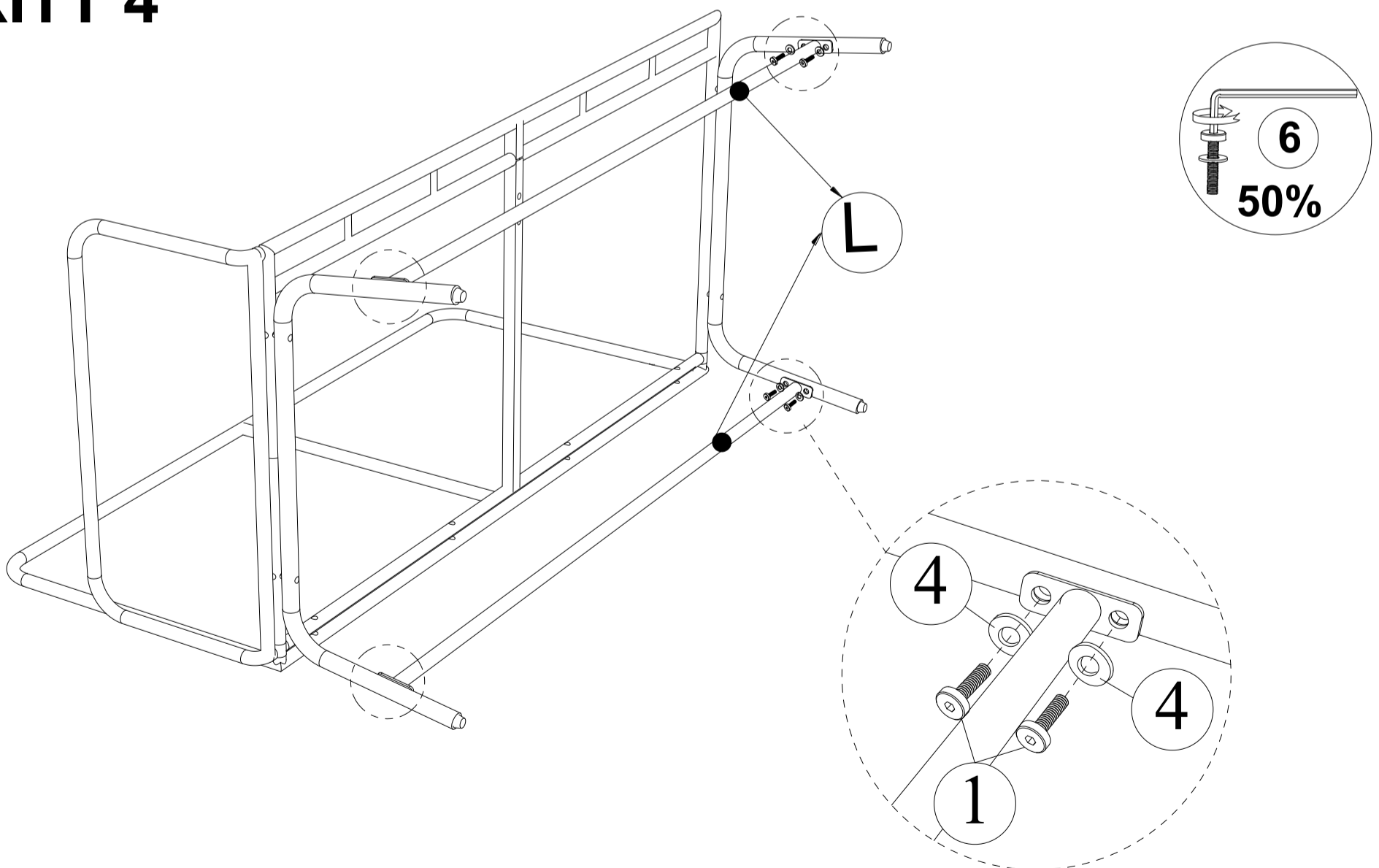

Verbinden Sie das Teil aus Schritt 3 und die lange Sammlung (L) und ziehen Sie die Schraube (1) fest. & Unterlegscheibe (4) mit Inbusschlüssel (6).

SCHRITT 5

K x1

1 x2

4 x2

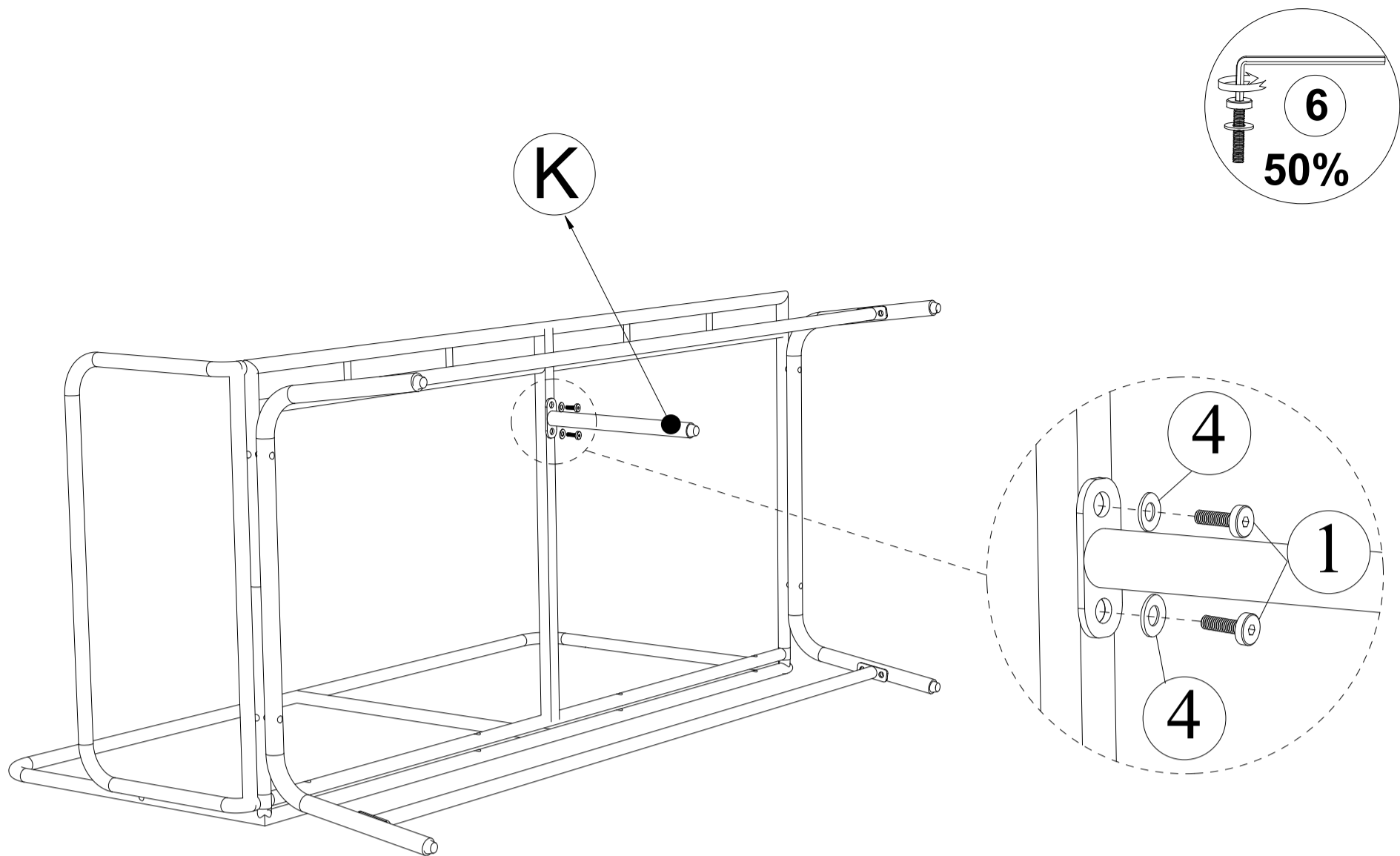

Verbinden Sie das Teil aus Schritt 4 und das Stützbein (K) und ziehen Sie die Schraube (1) fest. & Unterlegscheibe (4) mit Inbusschlüssel (6).

SCHRITT 6

8 x1

1 x2

4 x2

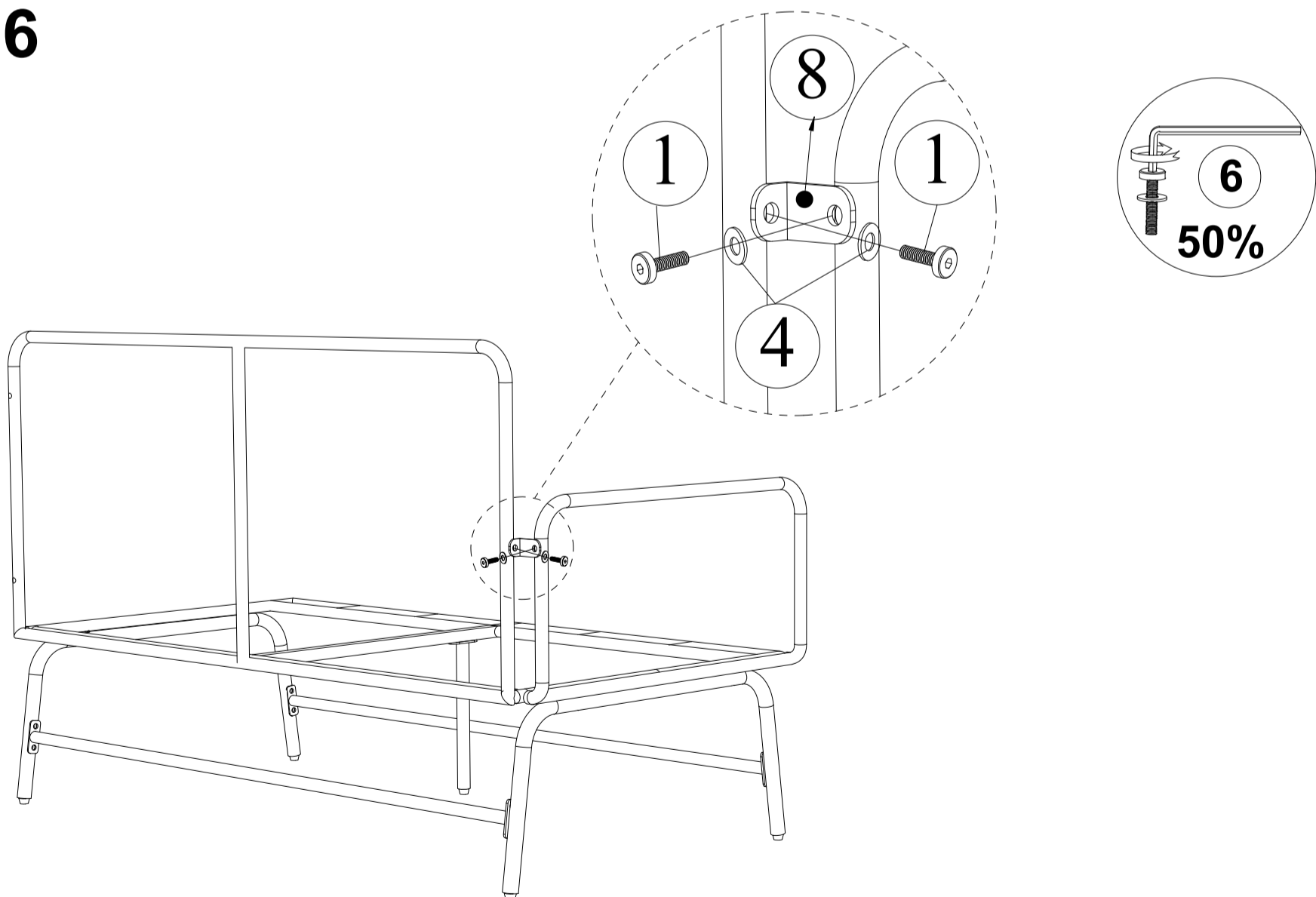

Stellen Sie das Teil aus Schritt 5 aufrecht hin & Connect Square-Kollektion (8), Schraube festziehen (1) & Flache Unterlegscheibe (4) mit Inbusschlüssel (6).

SCHRITT 7

RECHTES BANKGESTELL

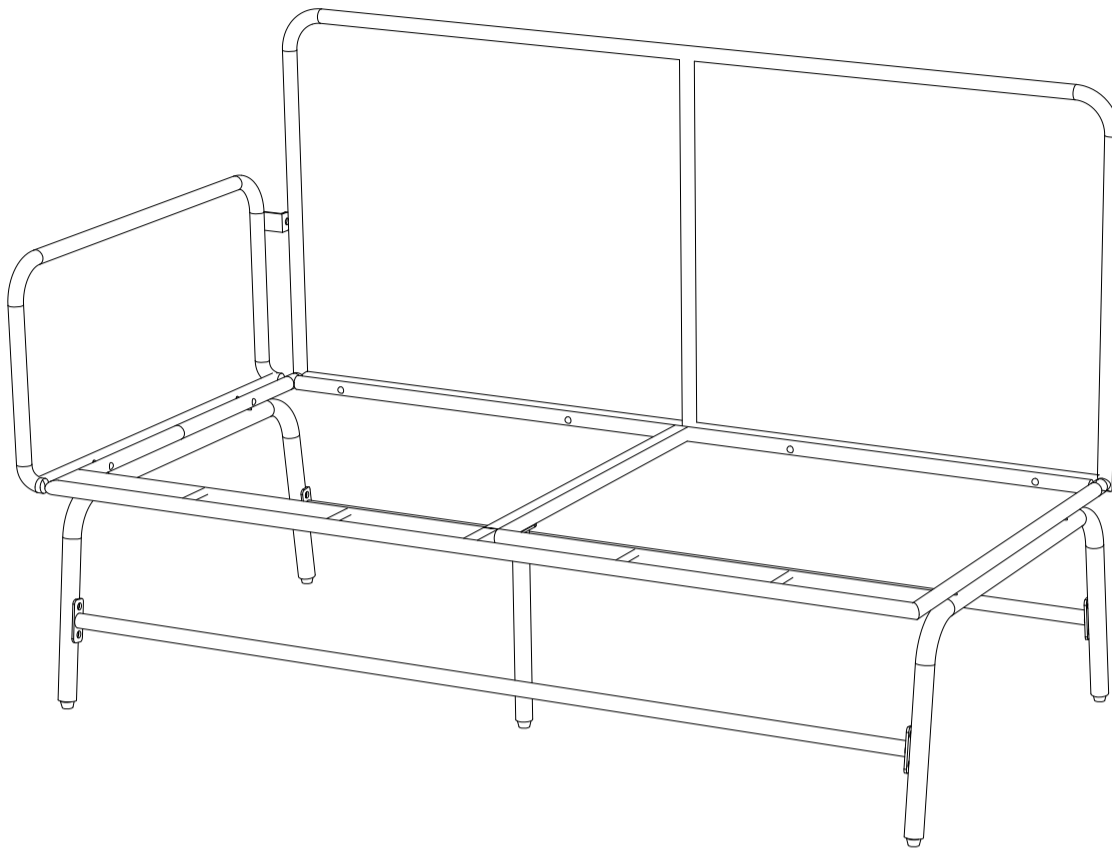
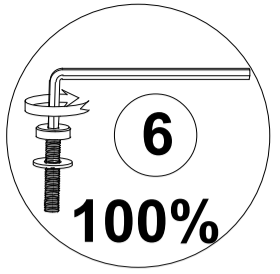

Ziehen Sie die Schrauben mit einem Inbusschlüssel fest an (6) & Beenden Sie den rechten Bankrahmen.

SCHRITT 8

B x1

E x1

3 x2

4 x2

ENTFERNEN
DER SCHUTZ
AUF DEM STÜCK

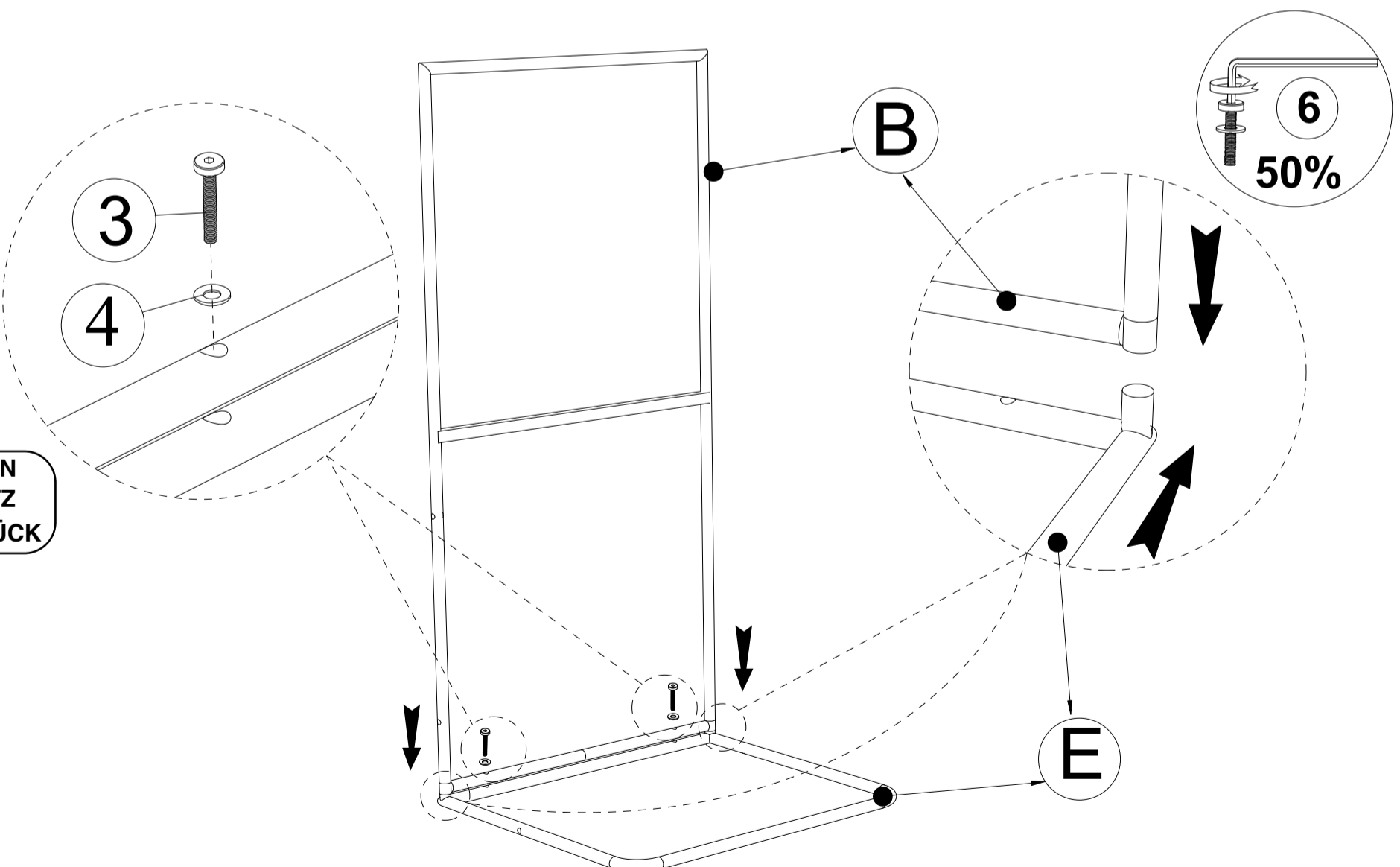

Drücken Sitzbank 2 verbinden (B) & Lange Rückbank (E), Schraube festziehen (3) Unterlegscheibe (4) mit Inbusschlüssel (6).

SCHRITT 9

G x1

3 x2

4 x2

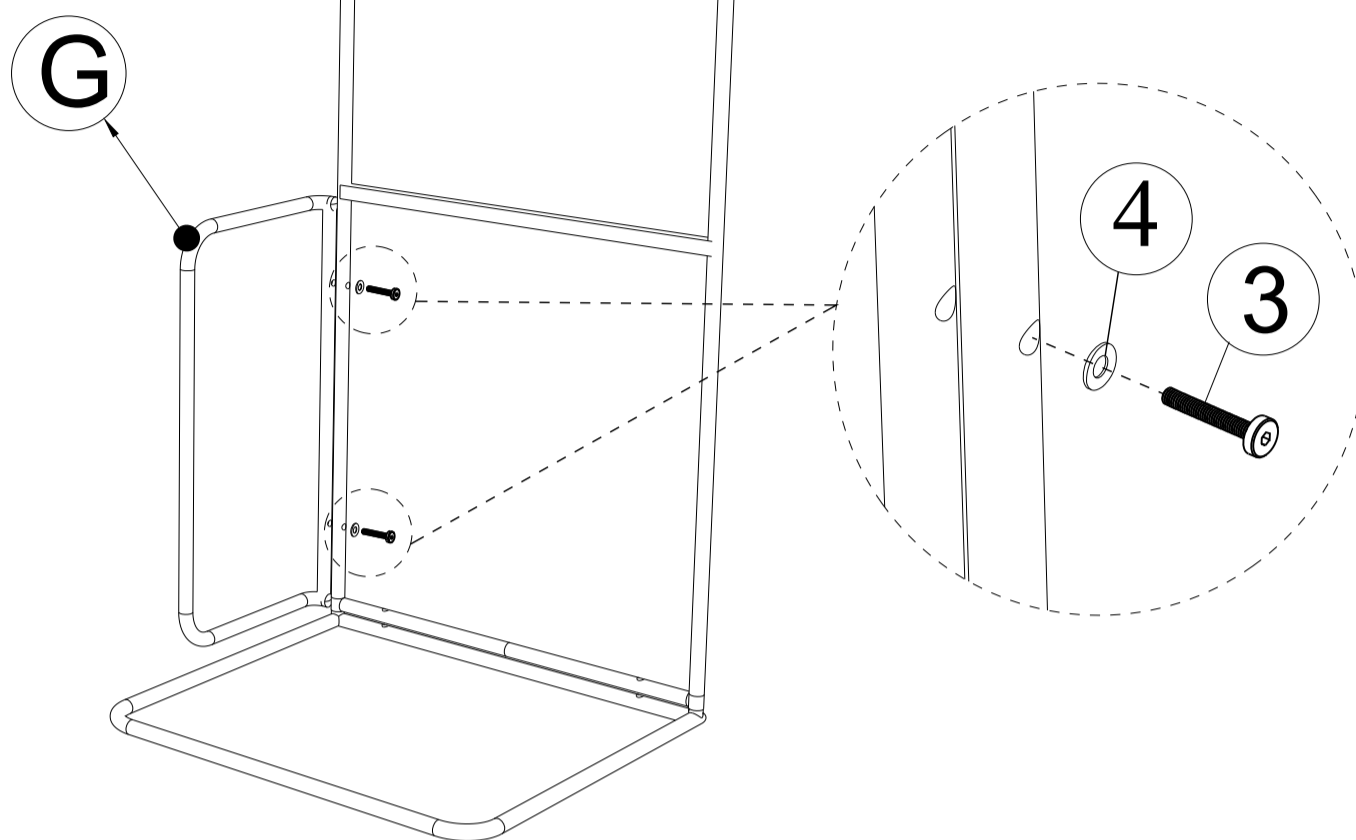
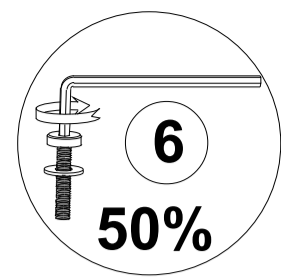

Verbinden Sie das Teil aus Schritt 8 & Linker Arm (G), Schraube festziehen (3) & flache Unterlegscheibe (4) mit Inbusschlüssel (6).

SCHRITT 10

I x2

3 x6

4 x6

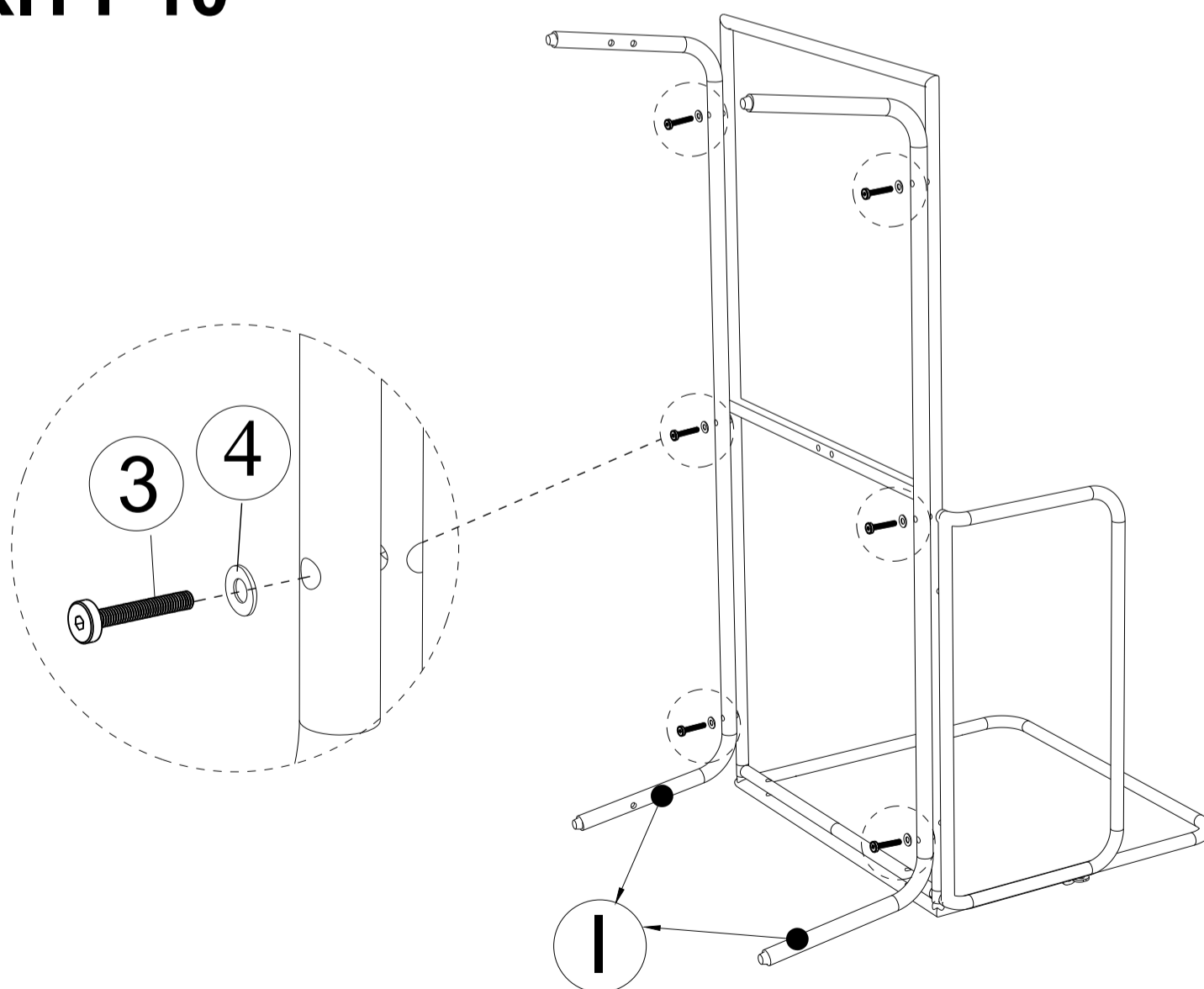
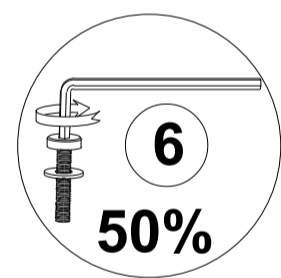

Verbinden Sie das Teil aus Schritt 9 & langes Bein (I), Schraube festziehen (3) & flache Unterlegscheibe (4) & Inbusschlüssel (6).

SCHRITT 11

N x2

1 x8

4 x8

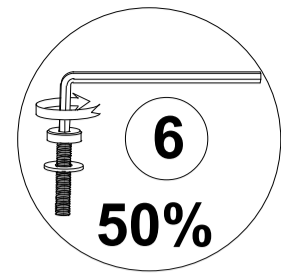
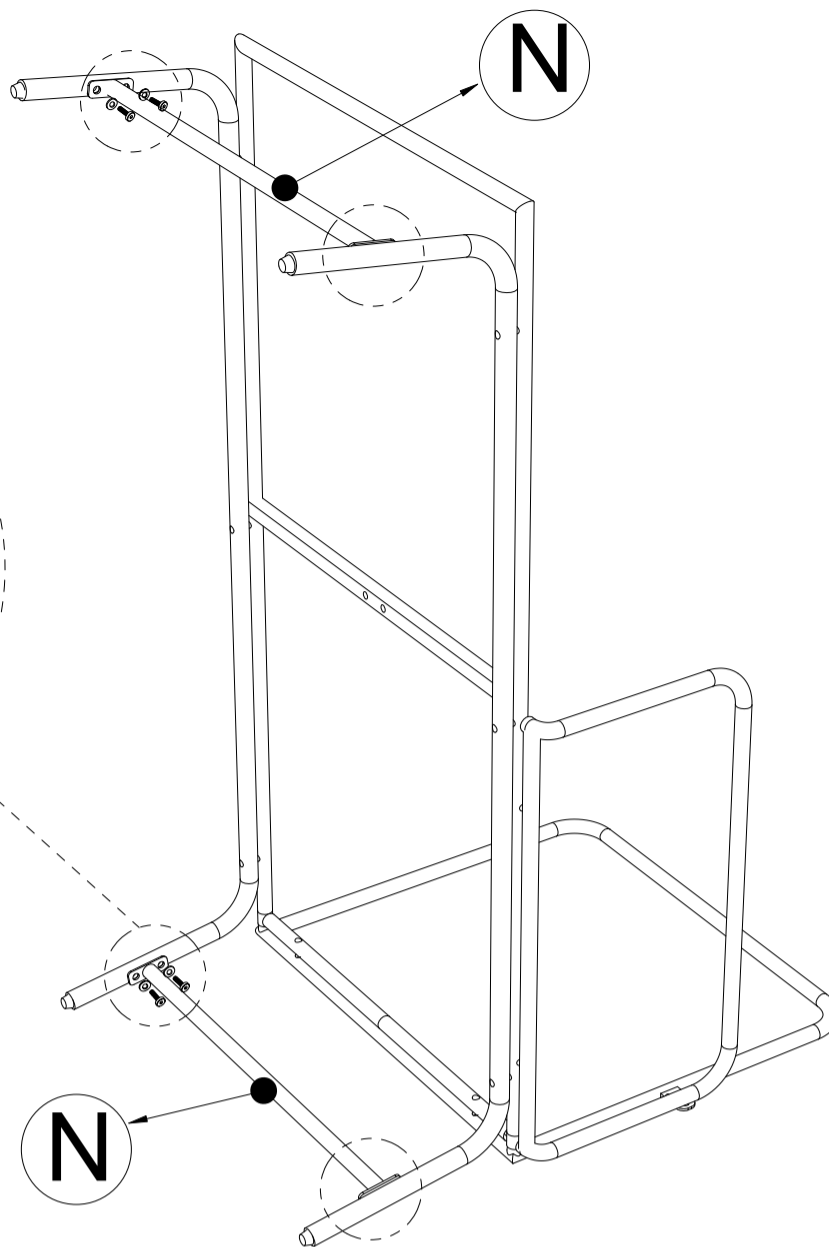
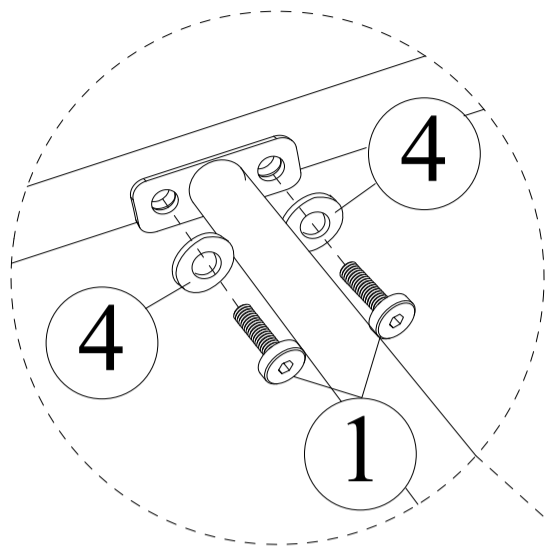

Verbinden Sie das Teil aus Schritt 10 & Kurzsammlung 1(N), Schraube festziehen (1) & Unterlegscheibe (4) & Inbusschlüssel (6).

SCHRITT 12

K x1

1 x2

4 x2

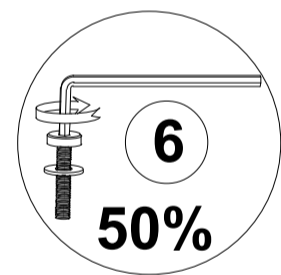
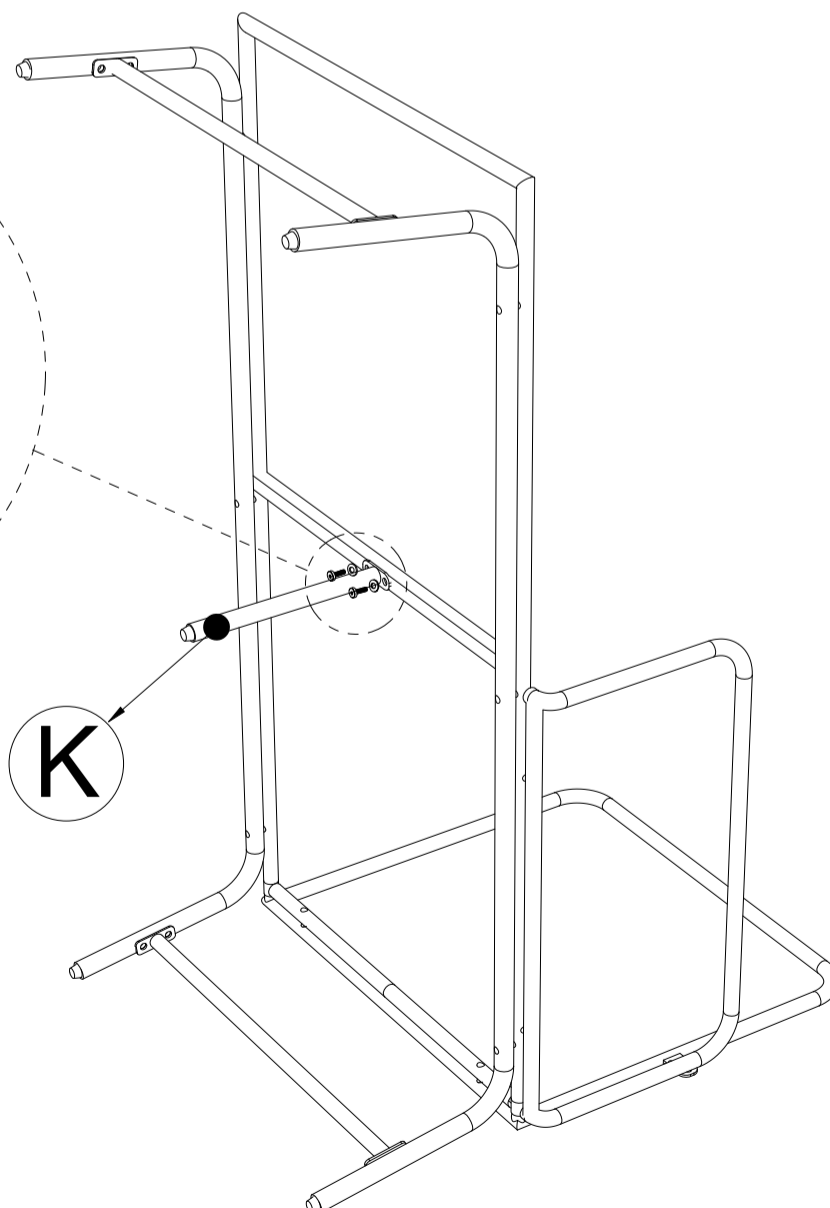
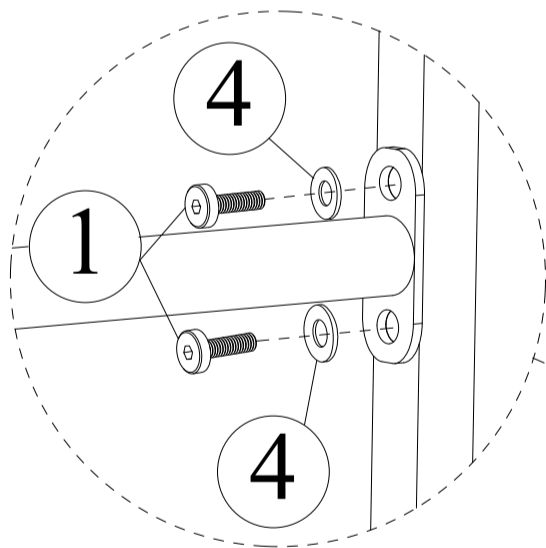

Verbinden Sie den Teil ab Schritt 11 & Stützbein (K), ziehen Sie die Schraube (1) & Unterlegscheibe (4) mit Inbusschlüssel (6).

SCHRITT 13

8 x1

1 x2

4 x2

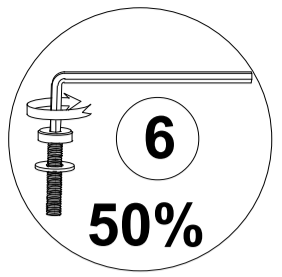
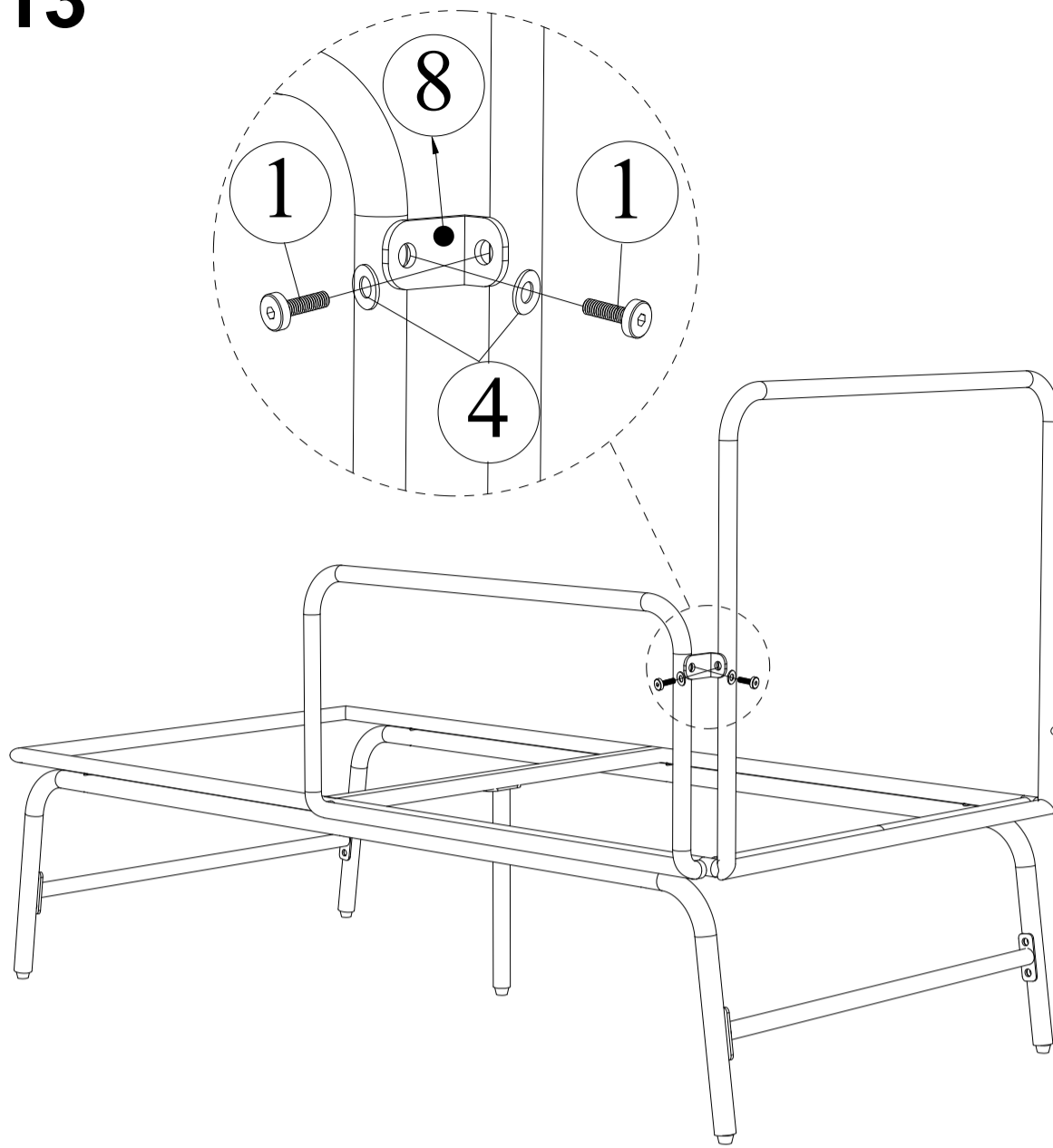

Stellen Sie das Teil aus Schritt 12 aufrecht hin & Connect Square-Kollektion (8), Schraube festziehen (1) & lache Unterlegscheibe (4) mit Inbusschlüssel (6).

SCHRITT 14

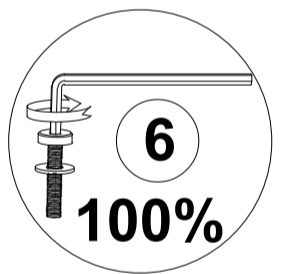
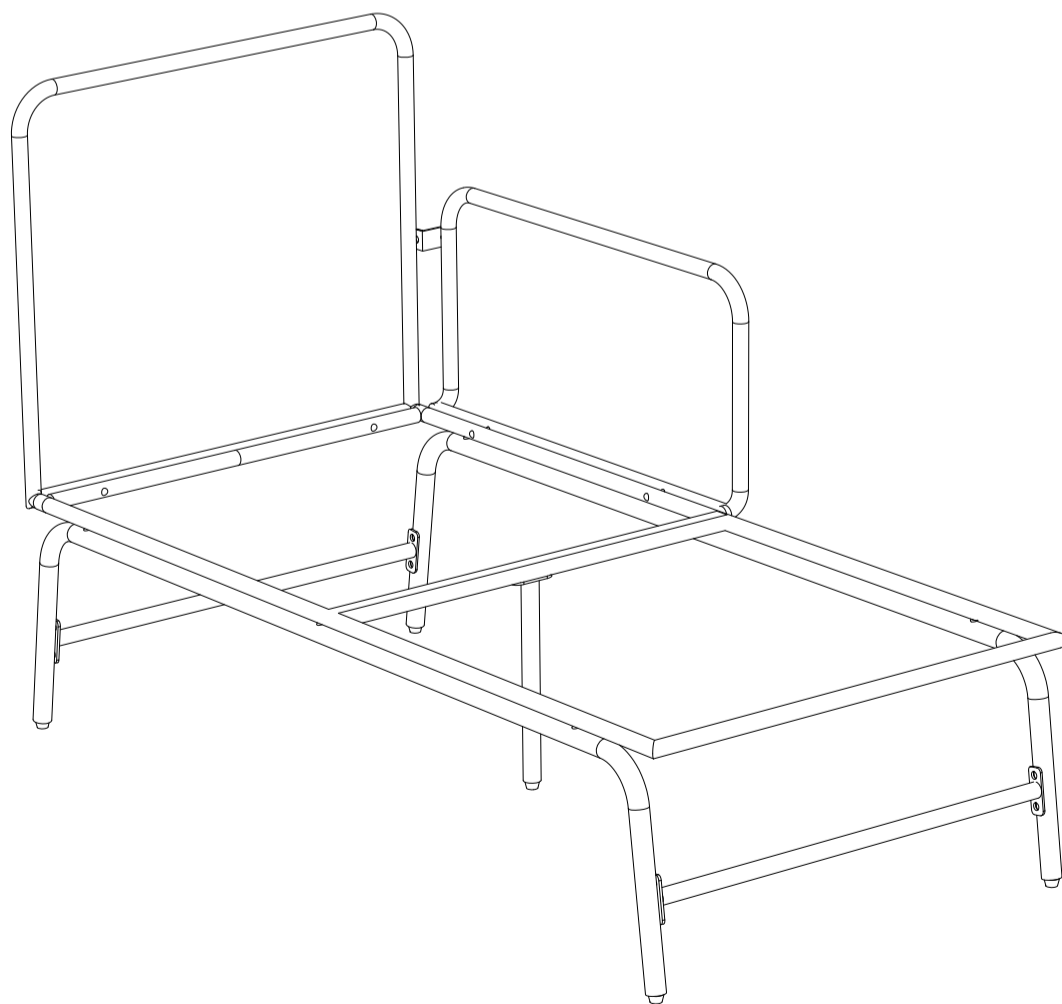

Ziehen Sie die Schrauben mit dem Inbusschlüssel (6) fest an und stellen Sie den linken Bankrahmen fertig

SCHRITT 15

9 x2

10 x1

1 x4

4 x4

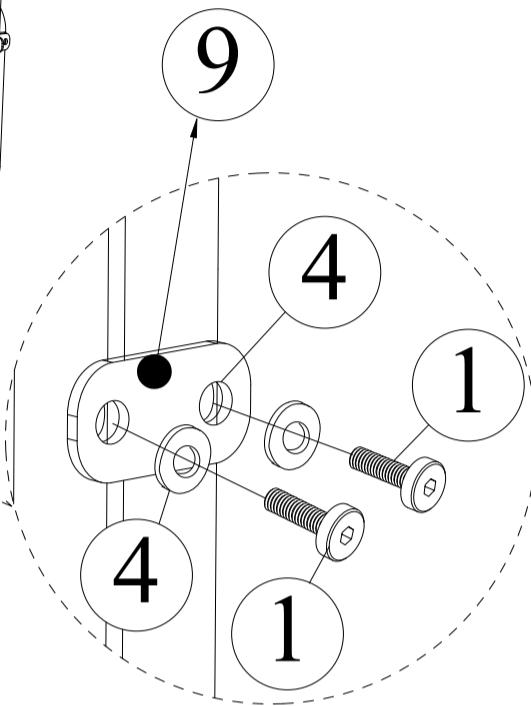
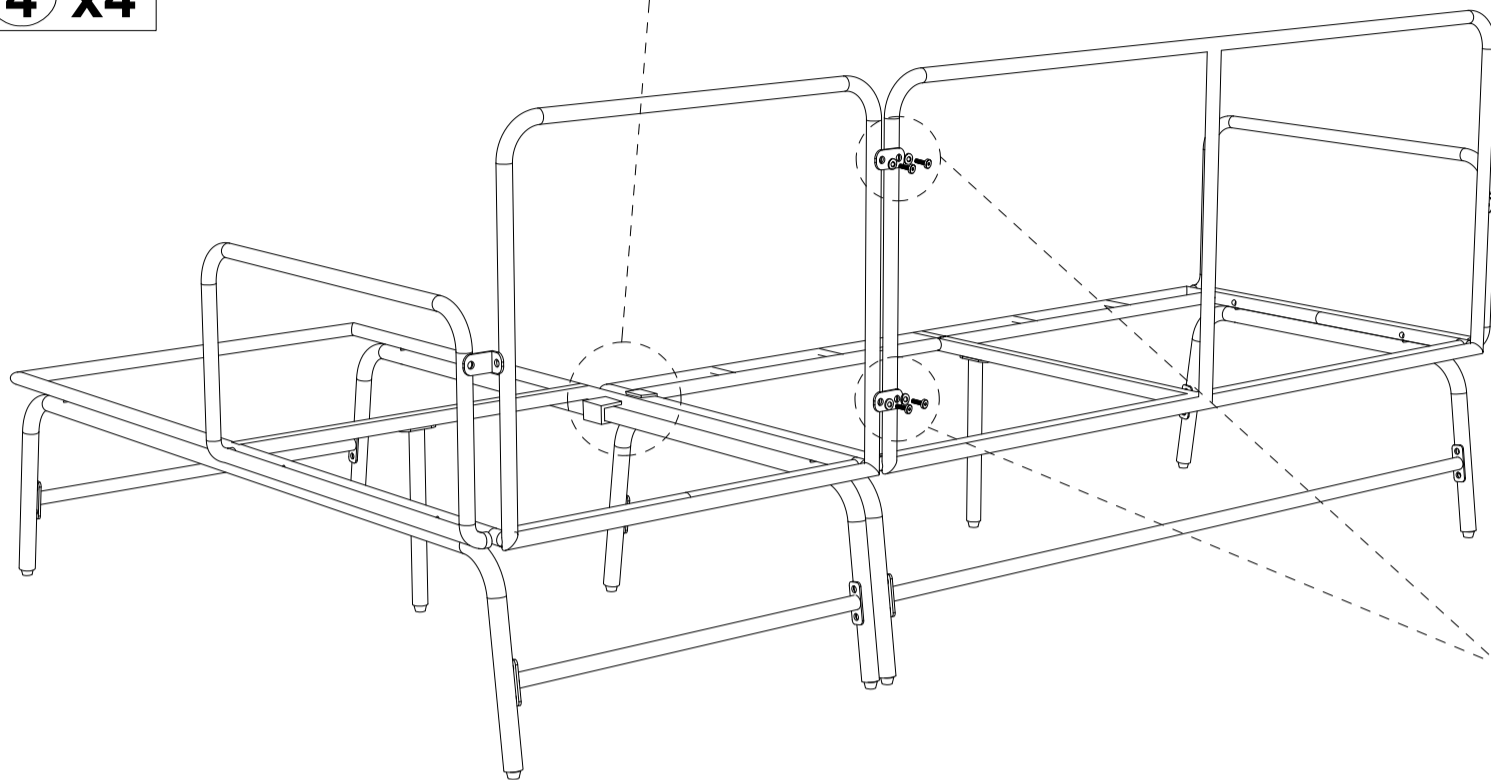
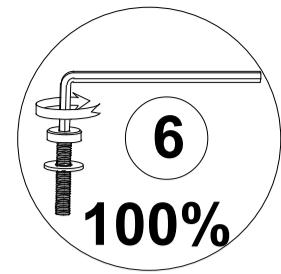
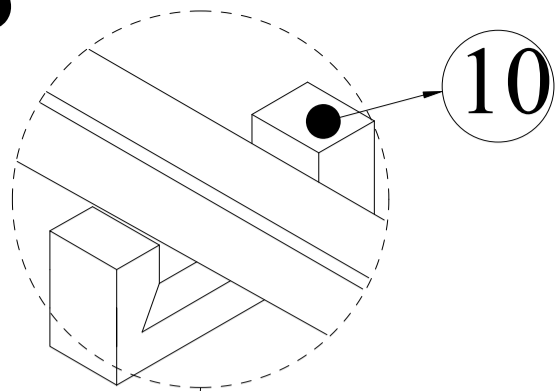

Verbinden Sie das Teil aus Schritt 14, den Teil aus Schritt 7 & Fläche Kollektion (9), U-Sharp-Sammlung (10) Schraube festziehen (1) & Fläche Unterlegscheibe (4) mit Inbusschlüssel (6).

SCHRITT 16

O x2

P x3

Q x2

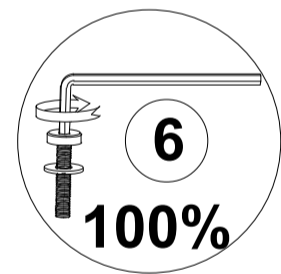
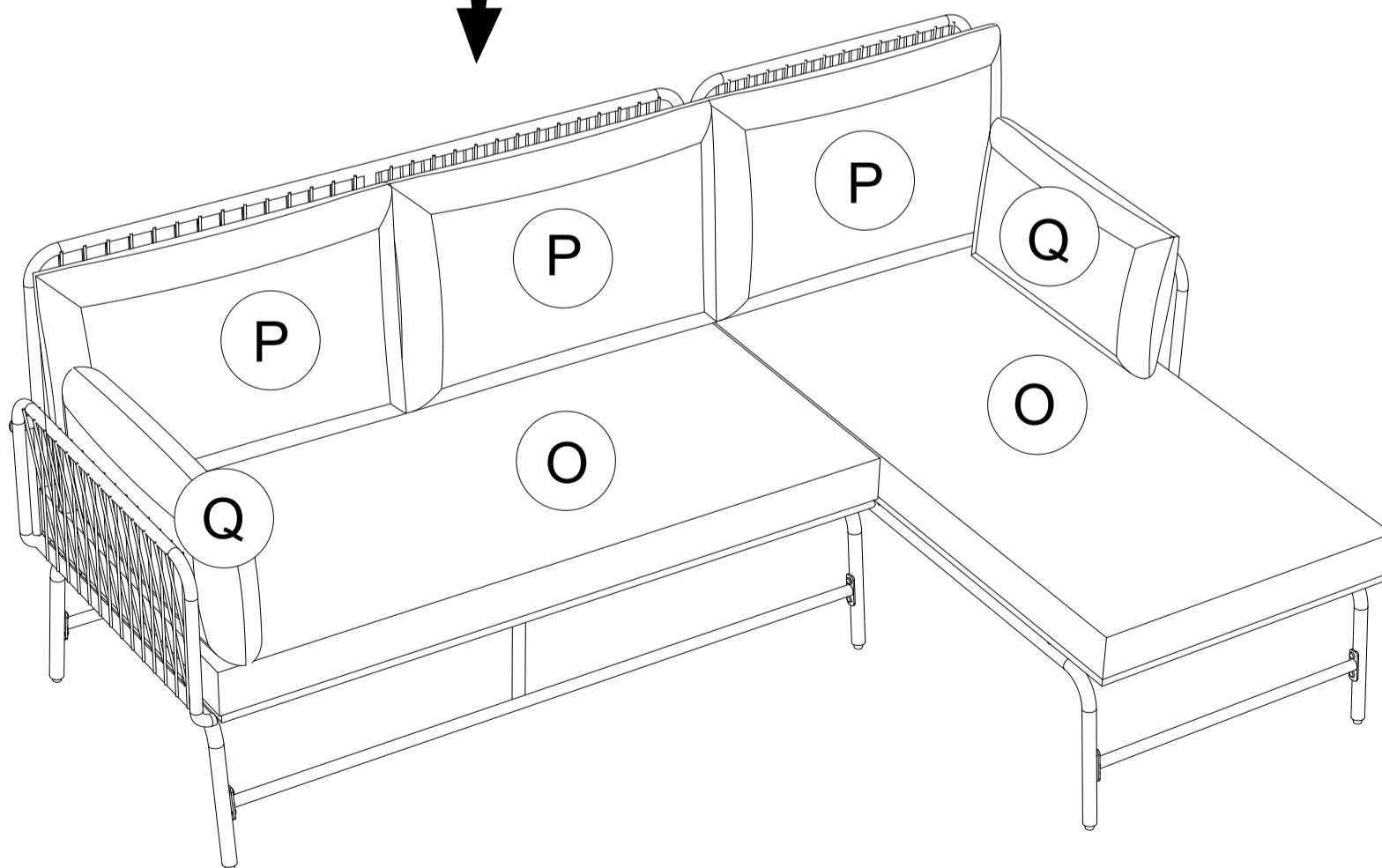

Platzieren Sie die Kissen (O)+(P)+(Q), um das Eckset fertigzustellen.

SCHRITT 17

Z x3

2 x6

4 x12

5 x6

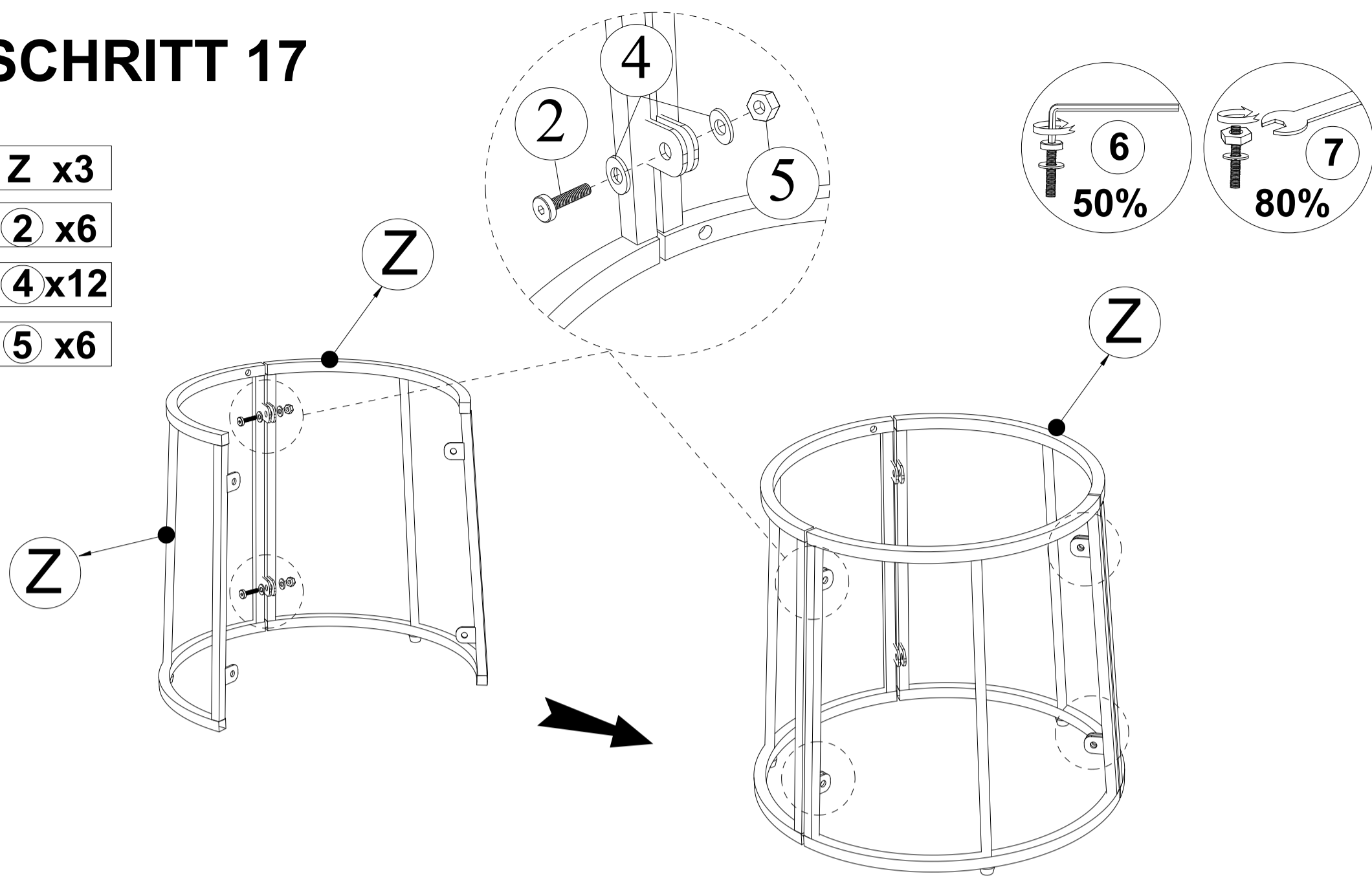

Verbinden Sie alle kleinen Tischbeine (Z) miteinander. Schraube (2) festziehen & Unterlegscheibe (4), Eru (5) mit Inbusschlüssel (6) & Schlüssel (7).

SCHRITT 18

X x1

1 x3

4 x3

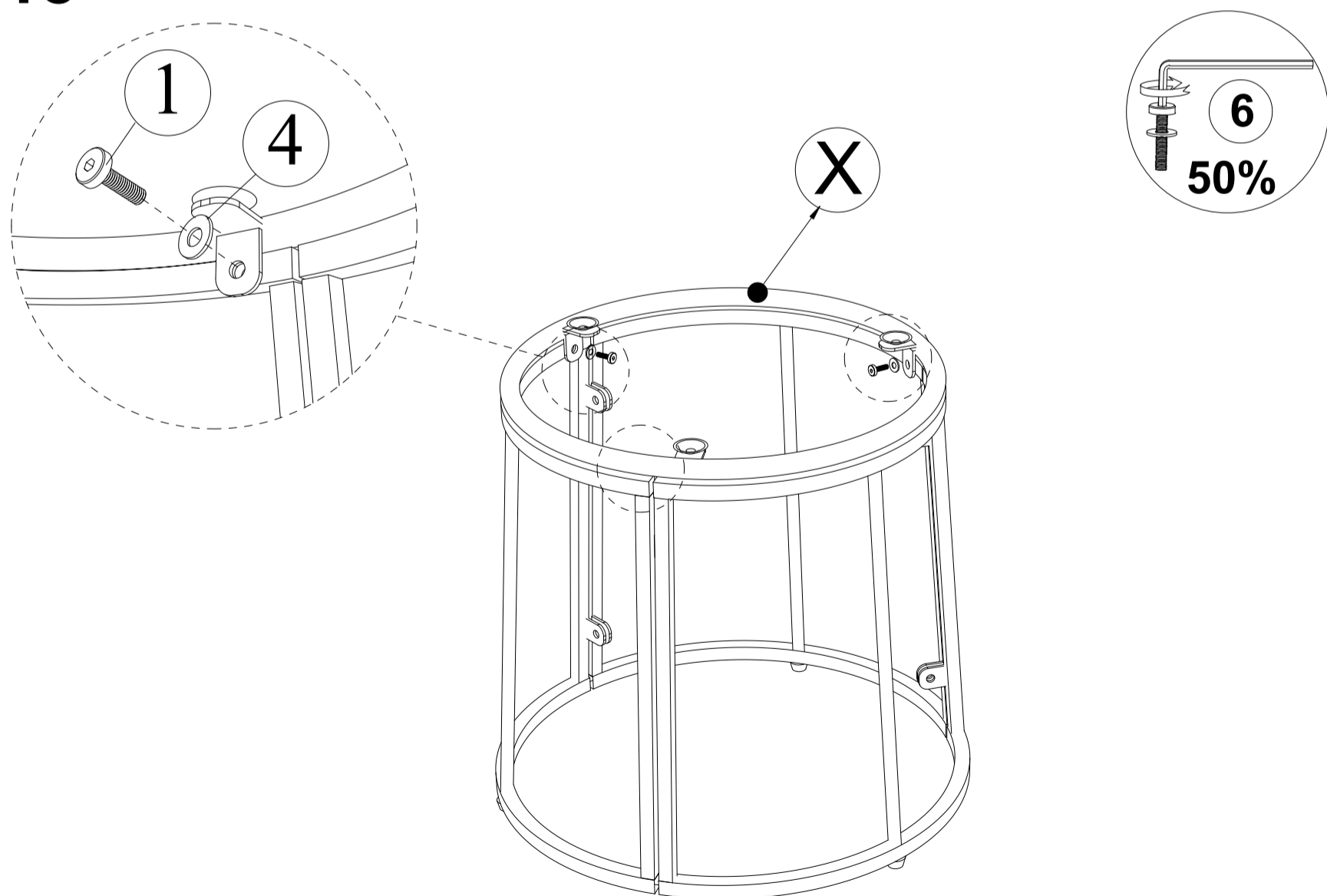

Verbinden Sie das Teil aus Schritt 17 & Oberen kleinen Tisch (X), Schraube festziehe (1) & Unterlegscheibe (4) mit Inbusschlüssel (6).

SCHRITT 19

T x1

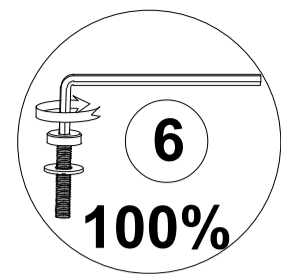
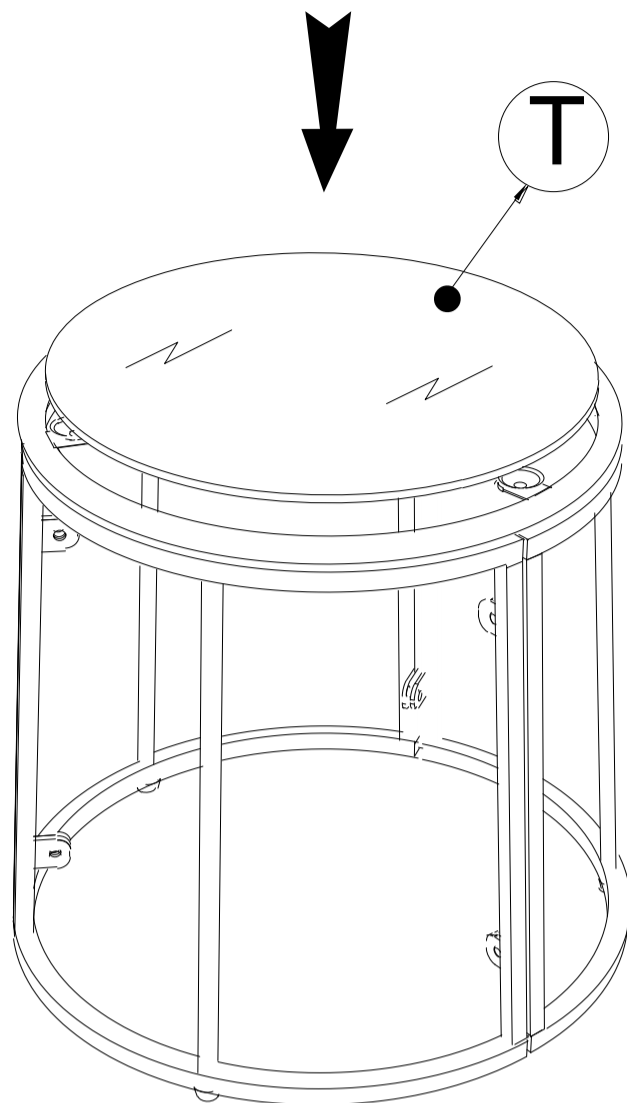

Ziehen Sie die Schrauben mit dem Inbusschlüssel (6) fest an. Setzen Sie die kleine Glasplatte (T) auf den oberen Rahmen.

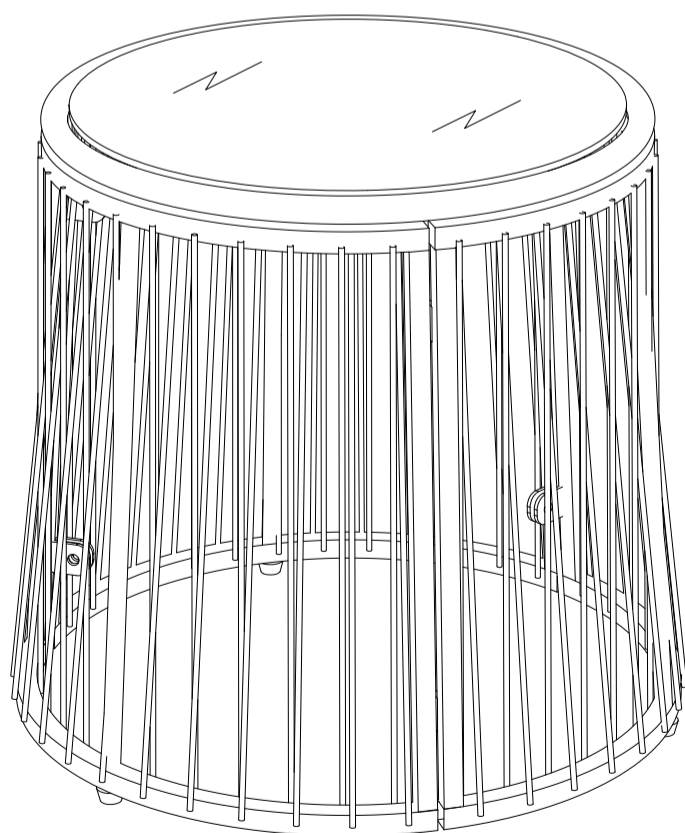

Beenden Sie den kleinen Tisch.

SCHRITT 20

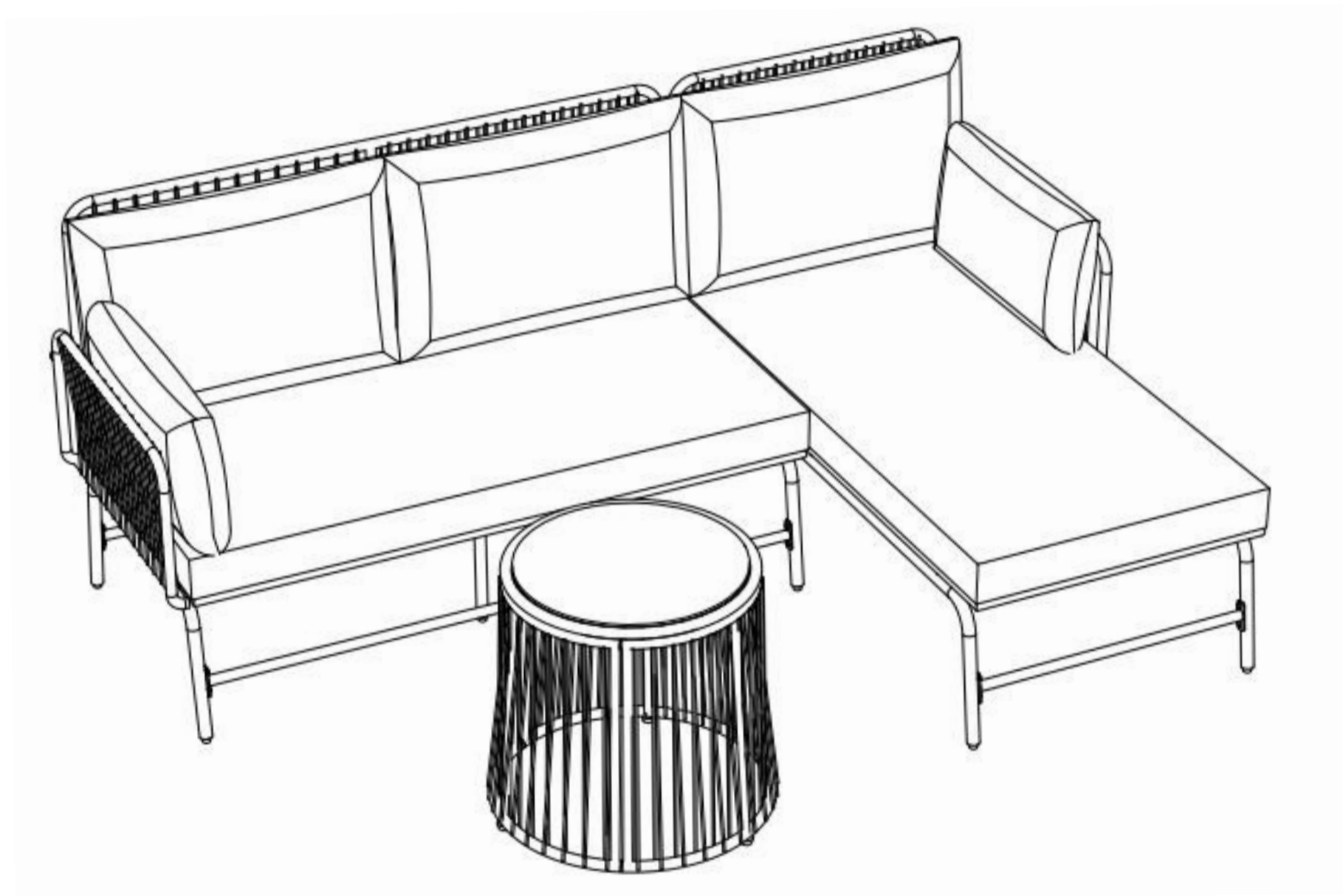

Richten Sie das Teil aus Schritt 16 ein & die Tisch-Sofagarnitur.

SCHRITT 21

C x1

F x1

3 x2

4 x2

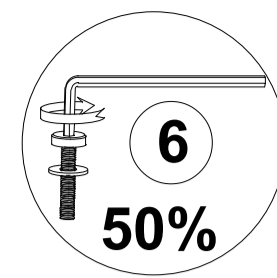
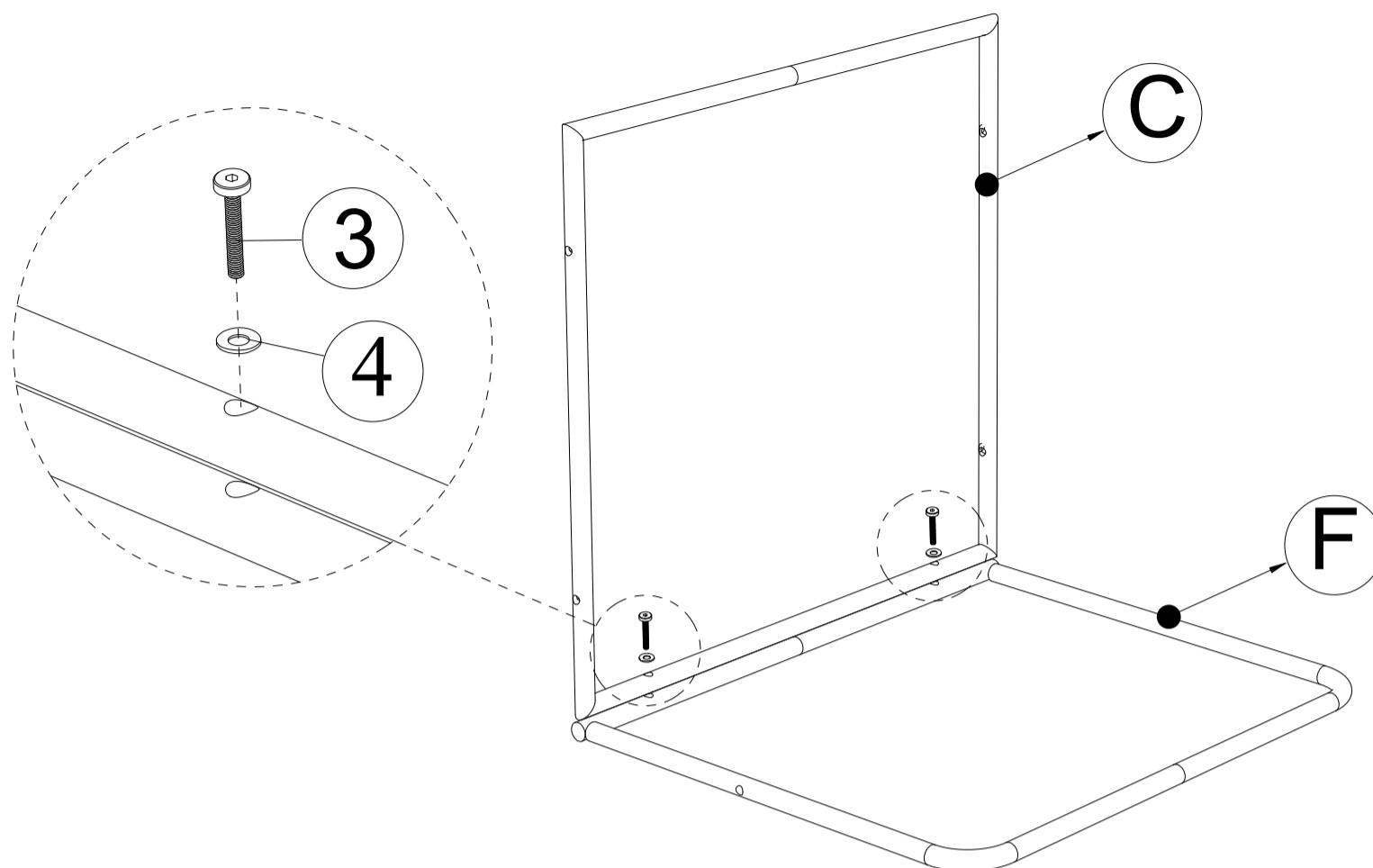

x2

Verbinden Sie den Sitzstuhl (C) und den Rückenlehnenstuhl (E), ziehen Sie die Schraube (3) und die Unterlegscheibe (4) fest. mit Inbusschlüssel (6)

SCHRITT 22

G x1

H x1

3 x4

4 x4

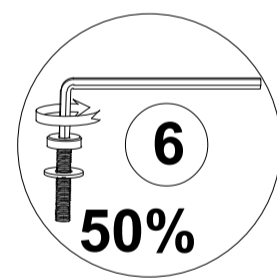
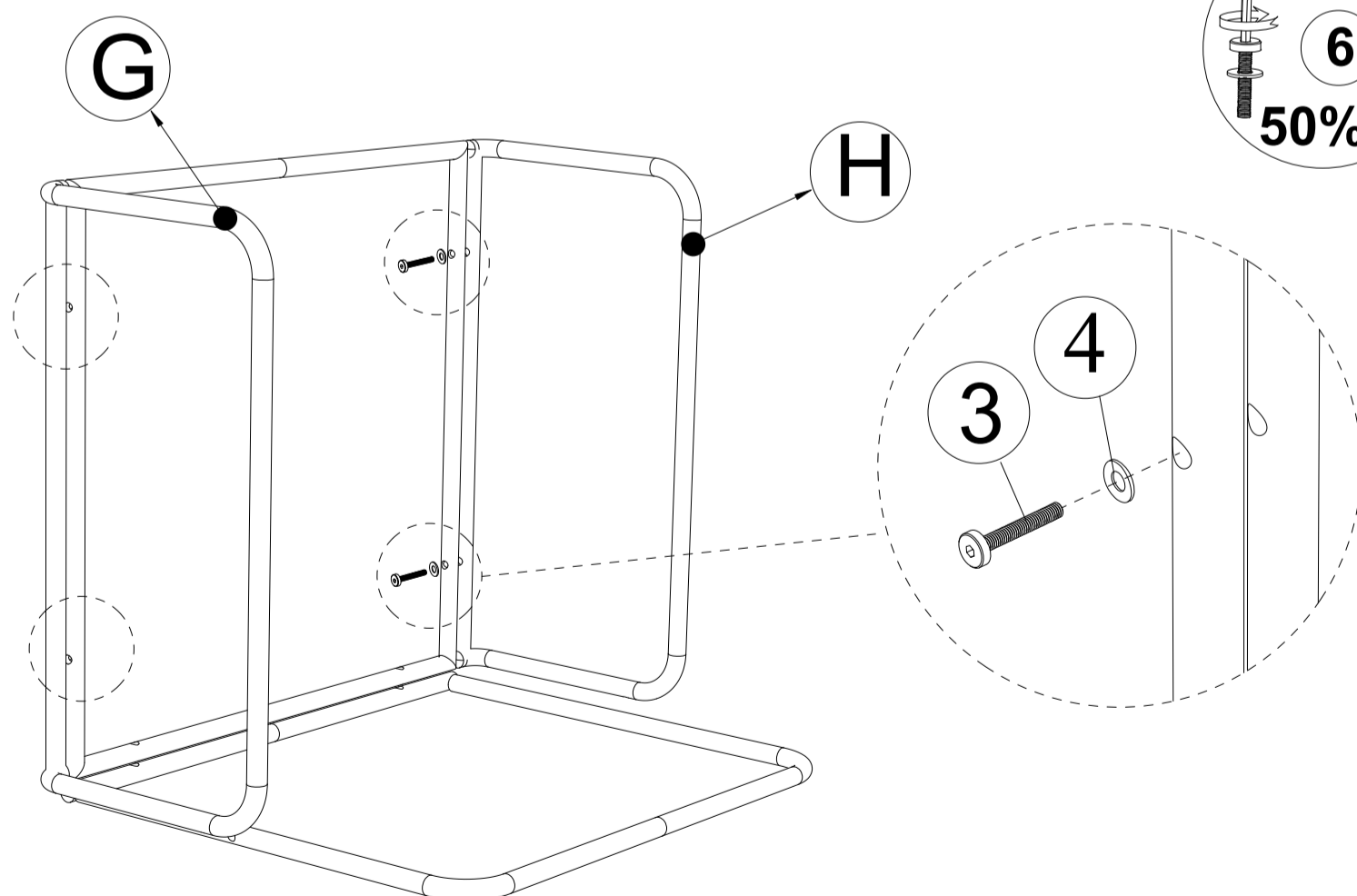

x2

Verbinden Sie das Teil aus Schritt 21 & Rechter Arm (H) & Linker Arm (G), Schraube festziehen & Unterlegscheibe (4) mit Inbusschlüssel (6).

SCHRITT 23

J x2

3 x4

4 x4

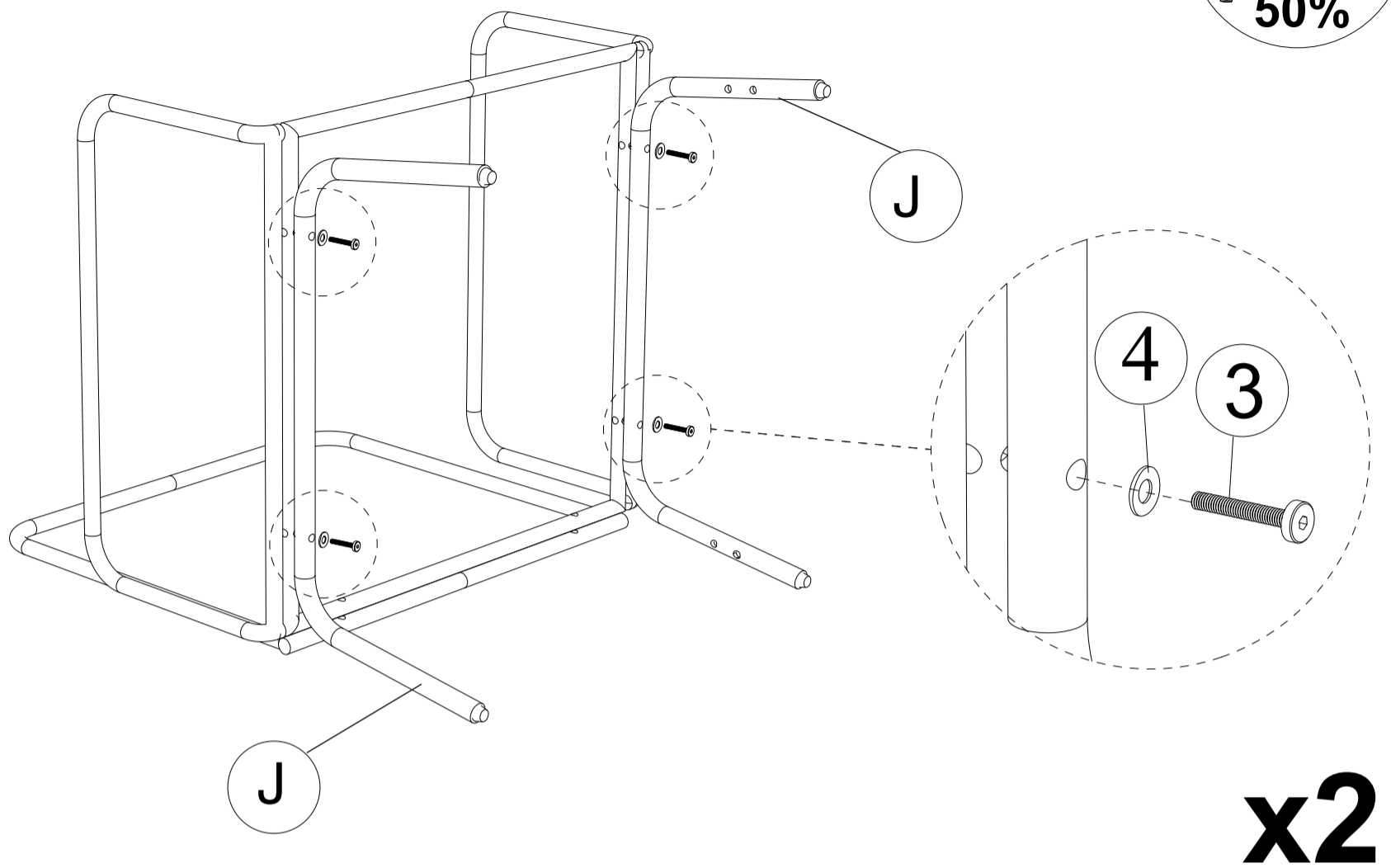

x2

Verbinden Sie das Teil aus Schritt 22 & Short Leg (J), Schraube festziehen (3) & Unterlegscheibe (4) mit Inbusschlüssel (6).

SCHRITT 24

M x2

1 x8

4 x8

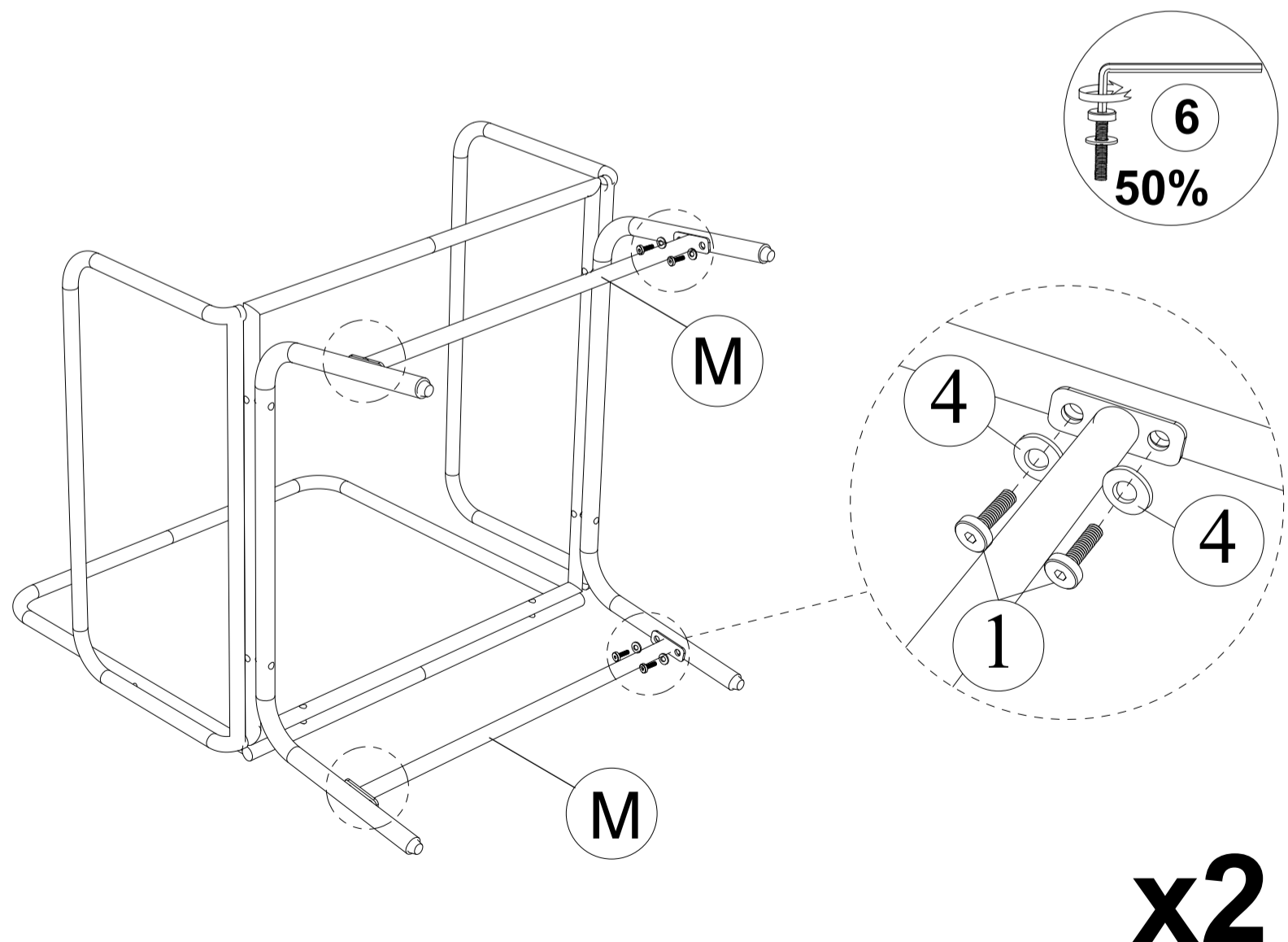

x2

Verbinden Sie das Teil aus Schritt 23 & Kurzkollektion 2 (M), Schraube festziehen (1) & Unterlegscheibe (4) mit Inbusschlüssel (6).

SCHRITT 25

8 x2

1 x4

4 x4

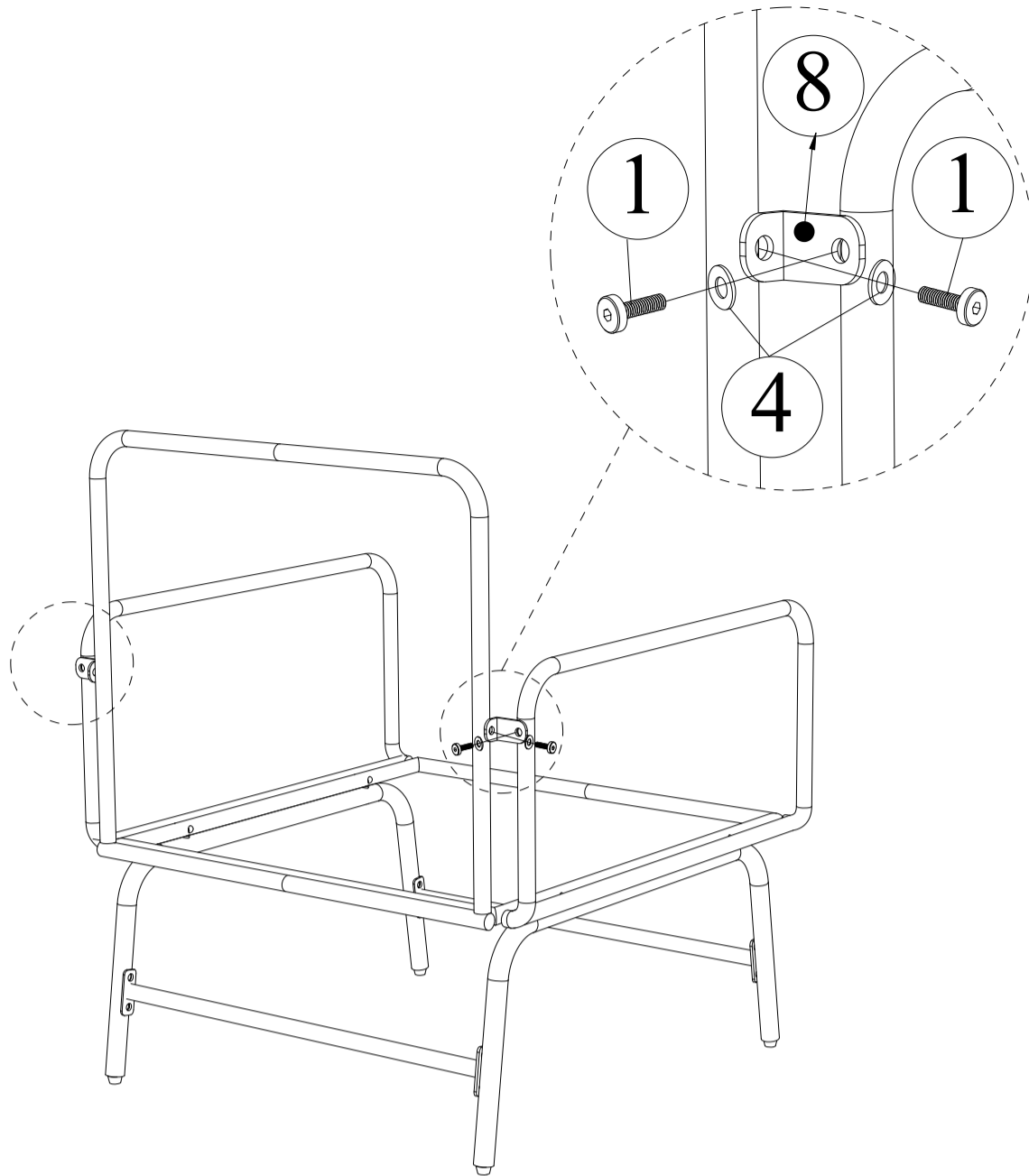

x2

Stellen Sie das Teil aus Schritt 24 aufrecht hin & Connect Square-Kollektion (8), Schraube festziehen (1) & Flache Unterlegscheibe (4) mit Inbusschlüssel (6).

SCHRITT 26

P x1

S x1

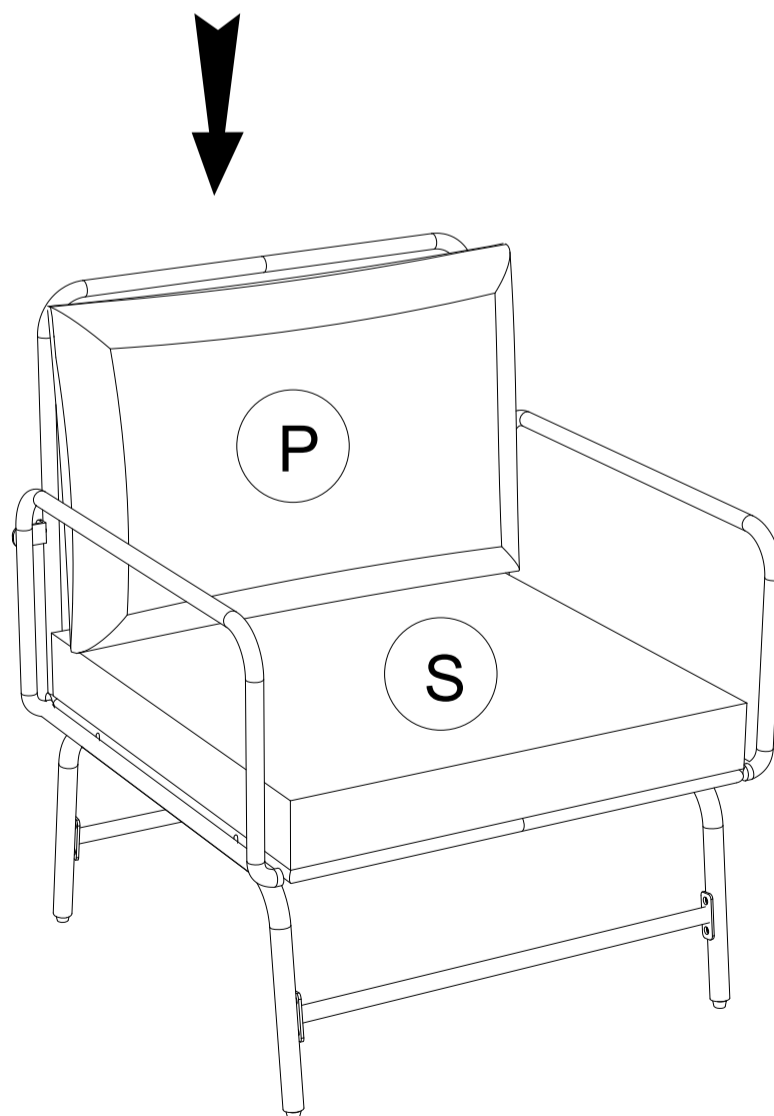

x2

Ziehen Sie die Schrauben mit dem Inbusschlüssel (6) fest an & Beenden Sie das Stuhlgestell. Richten Sie es ein Kissen (S)+(P).

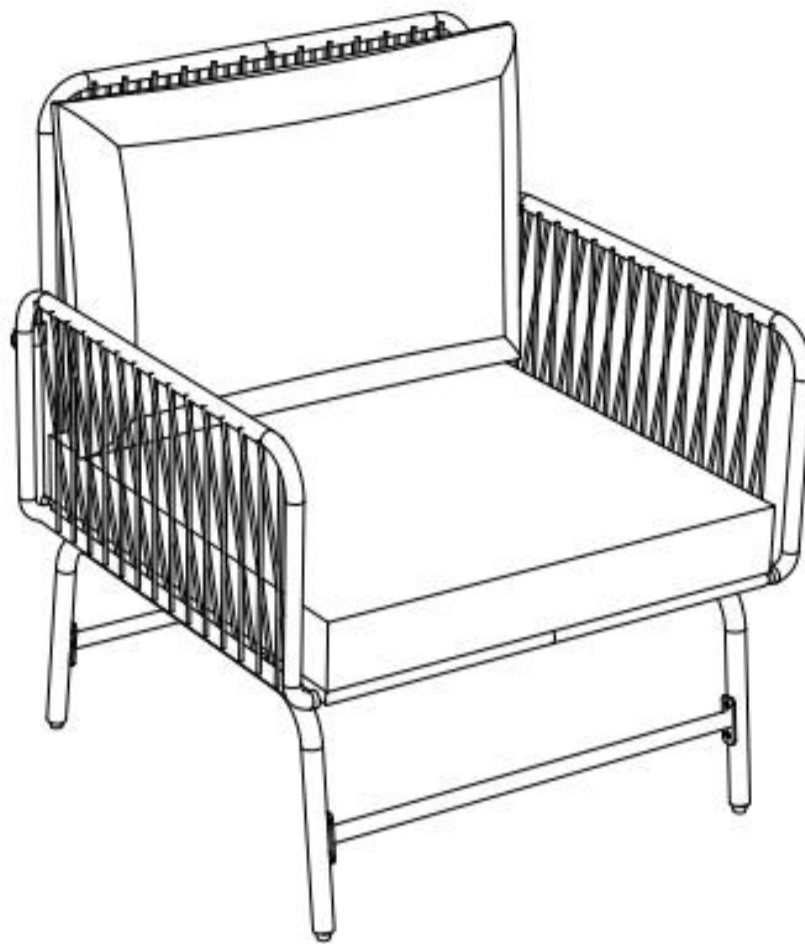

x2

Fertige Stühle.

SCHRITT 27

V x1

Y x2

1 x4

4 x4

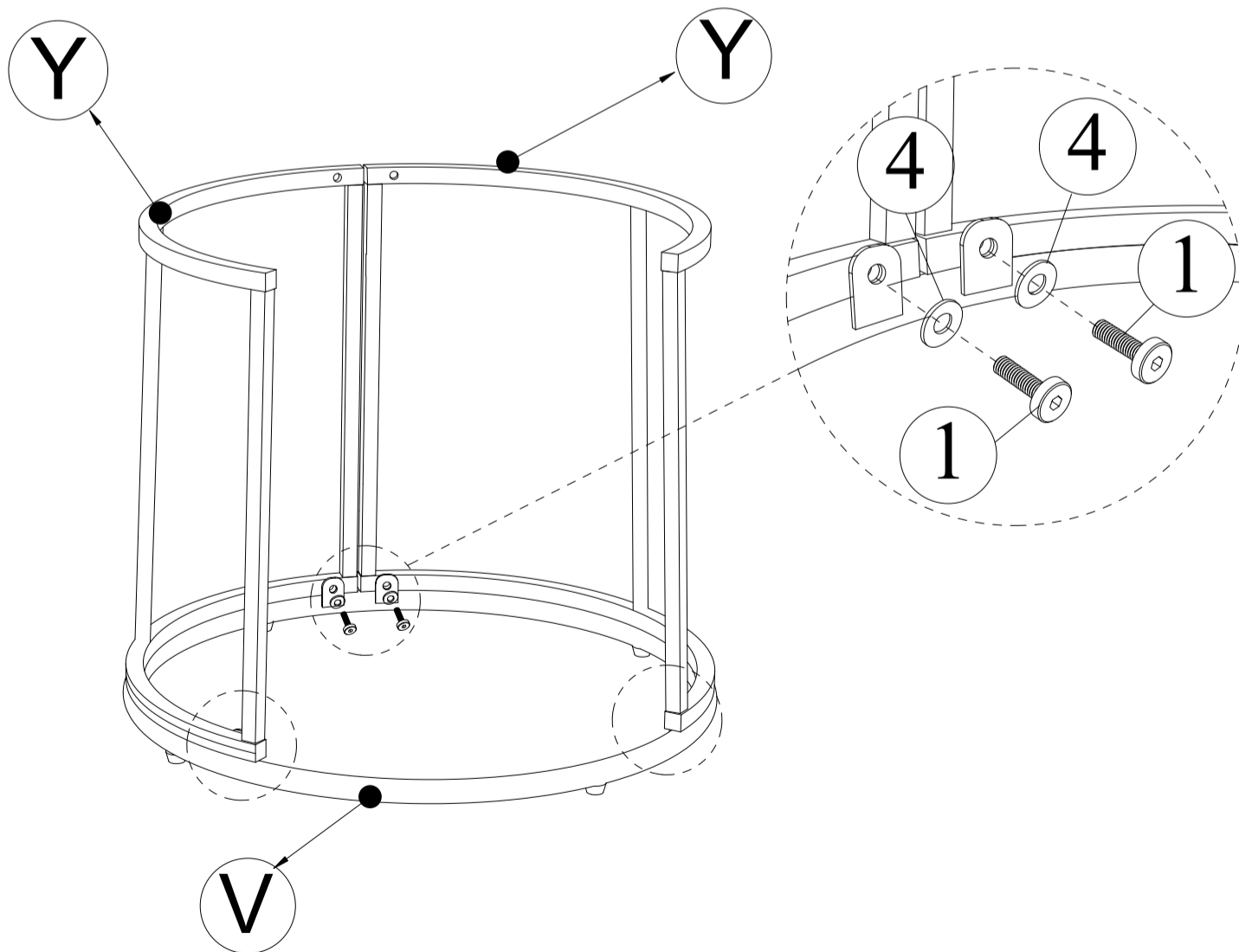

Großer Tisch mit Verbindungsbeinen (Y) & Bottom Big Table (V), Schraube festziehen (1) & Unterlegscheibe (4) mit Inbusschlüssel (6).

SCHRITT 28

U x1

1 x4

4 x4

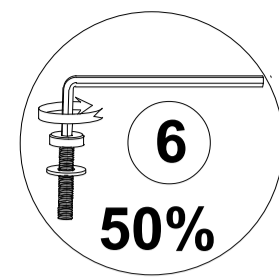
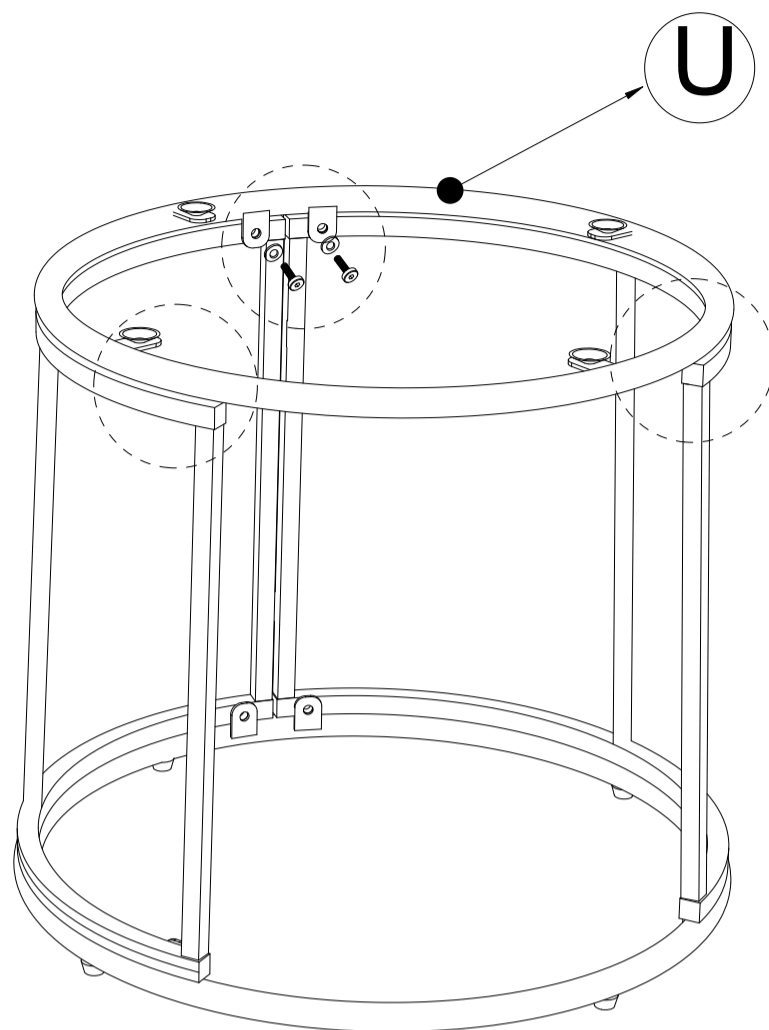
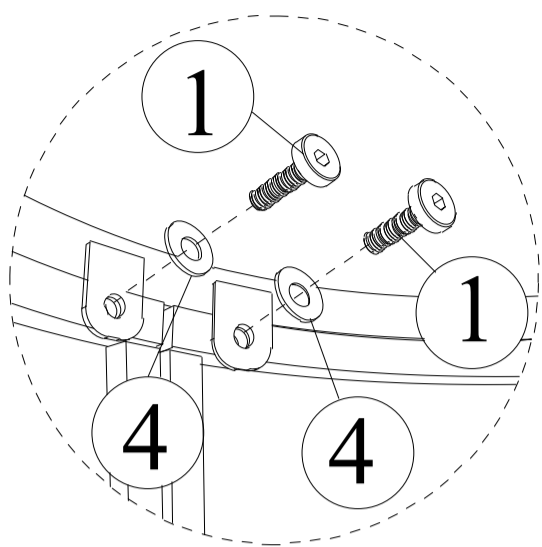

Verbinden Sie das Teil aus Schritt 27 & Oberen großen Tisch (U), Schraube festziehen (1) & Unterlegscheibe (4) mit Inbusschlüssel (6).

SCHRITT 29

R x1

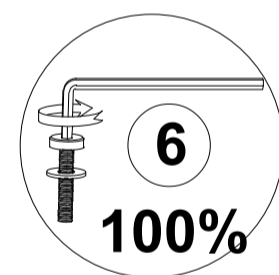
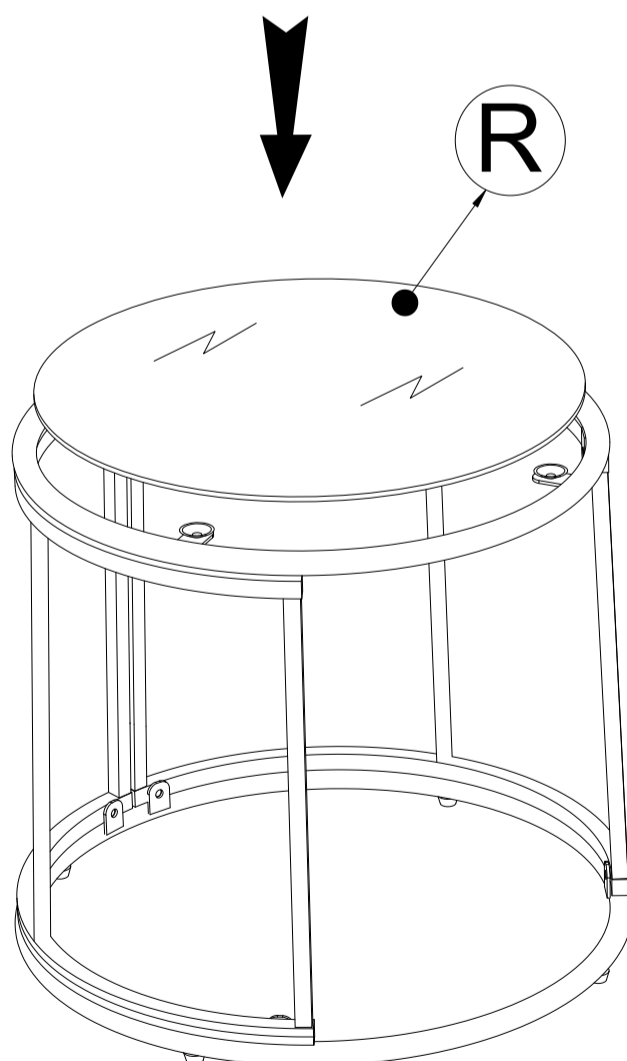

Ziehen Sie die Schrauben mit dem Inbusschlüssel (6) fest an. Setzen Sie die große Glasplatte (R) auf den oberen Rahmen.

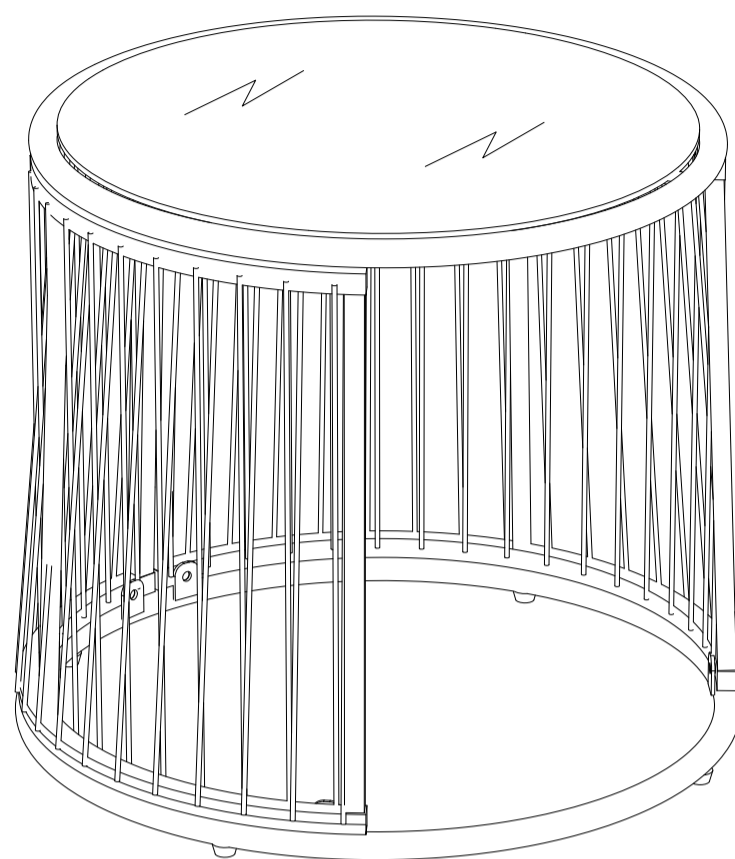

Beenden Sie den groen Tisch.

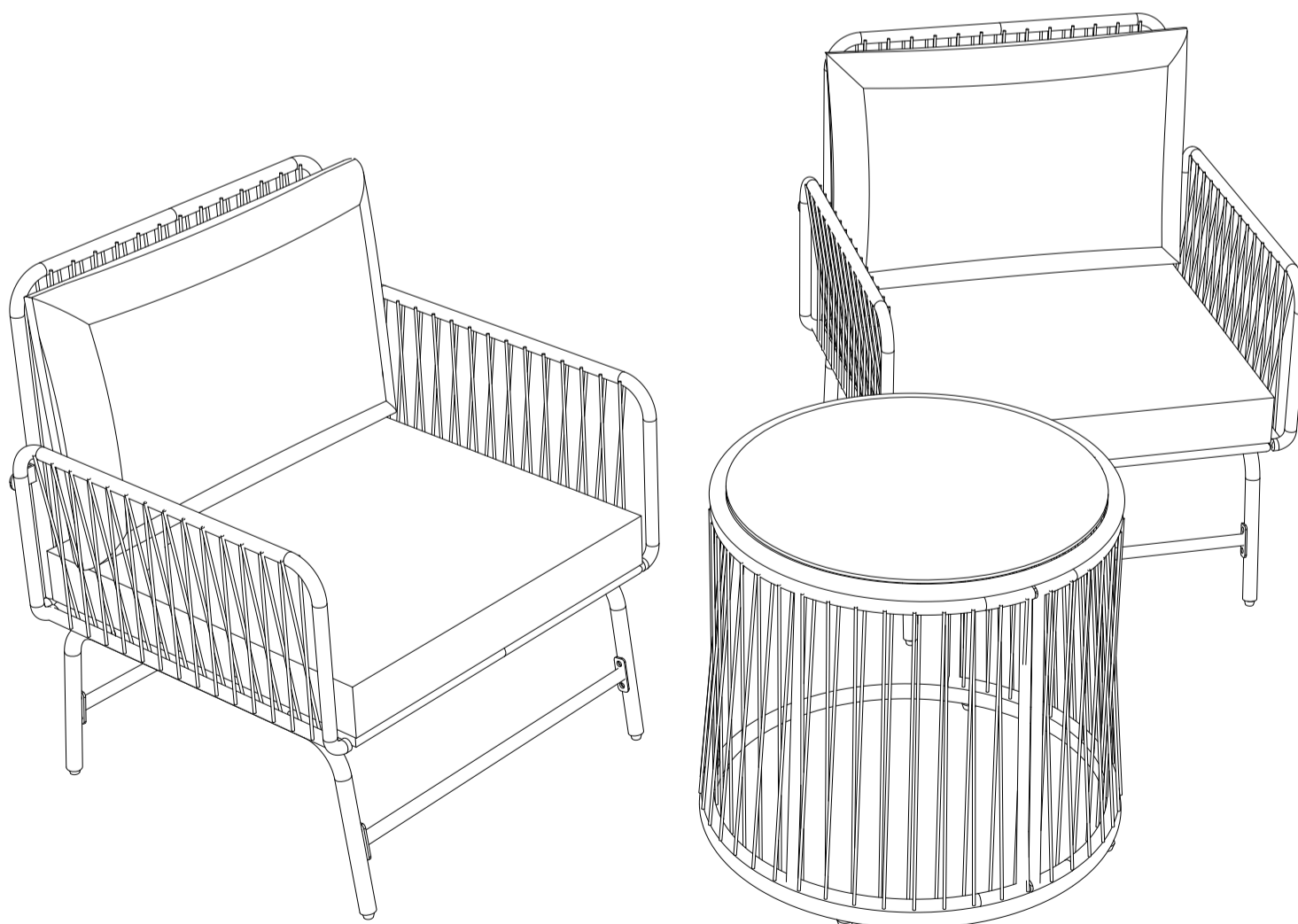

Stuhl einrichten & der große Tisch.

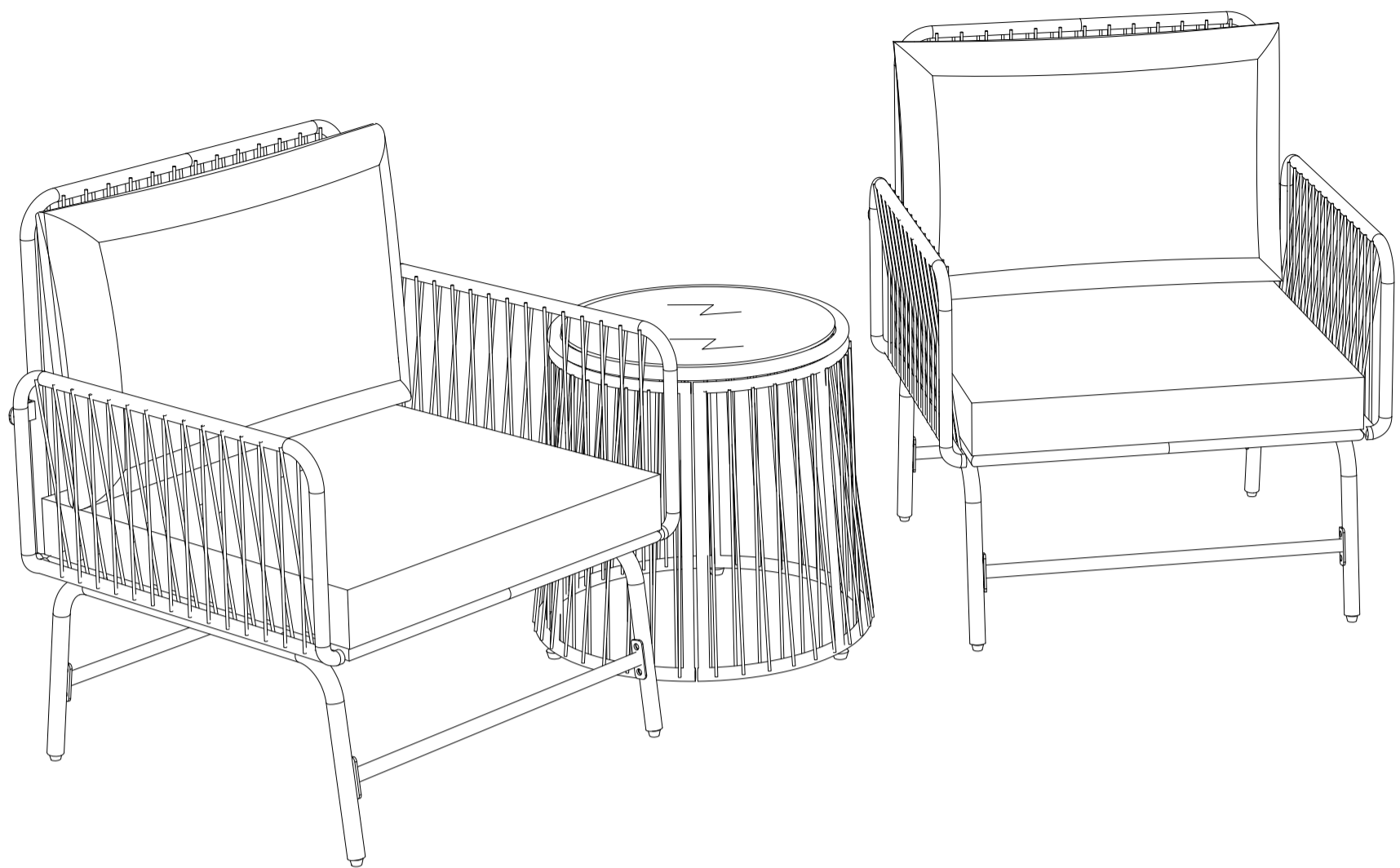

Stuhl einrichten & der kleine Tisch.

SCHRITT 30

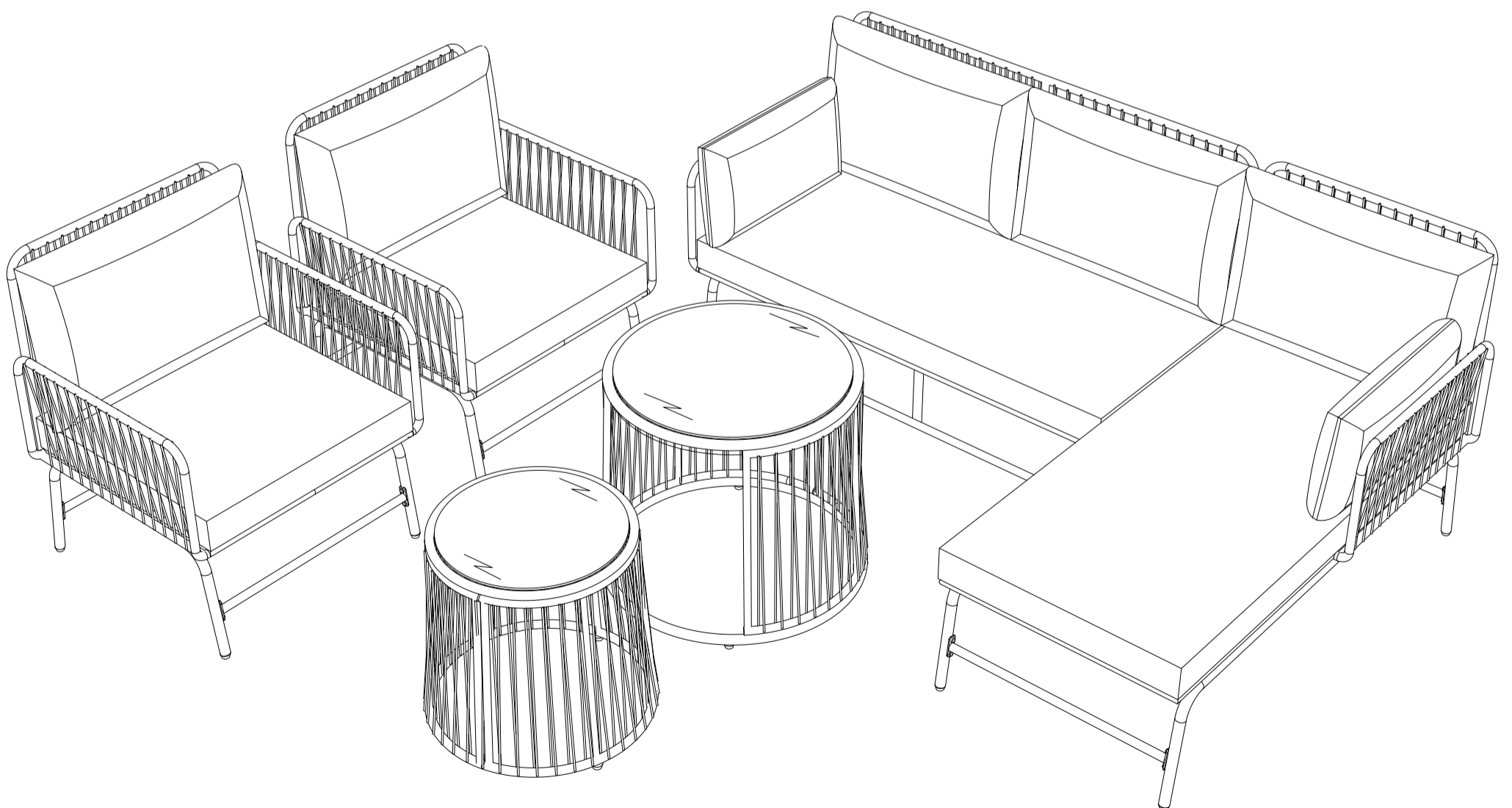

Stellen Sie Bänke, Stühle, kleinen Tisch und großen Tisch auf.