

Modell: STUDIO LINE 21

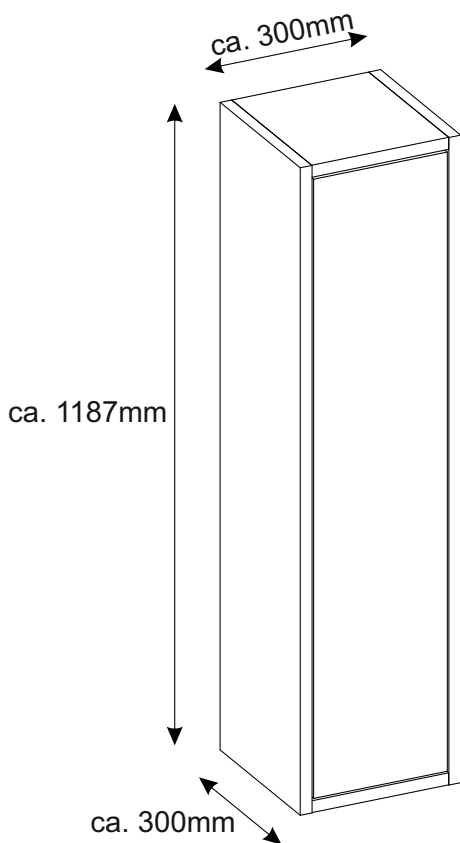

- Ⓛ Montageanleitung
- ⓃL Handleiding voor de montage
- ⓂR Montaj talimati
- Ⓛ Notice de montage
- ⓃZ Montážní návod
- ⓂU Szerelési útmutató
- ⓂB Assembly instructions
- ⓂL Instrukcja montażu
- ⓂU Инструкция по монтажу
- ⓂT Istruzioni di montaggio
- ⓂK Návod na montáž
- ⓂO Instrucțiuni de montaj
- ⓂS Instrucciones de montaje
- ⓂR Montaj Talimati

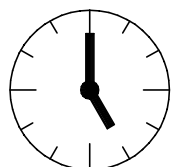
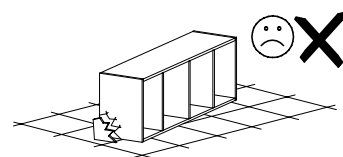
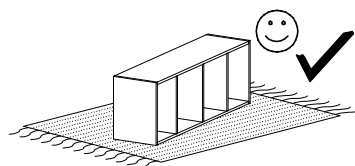
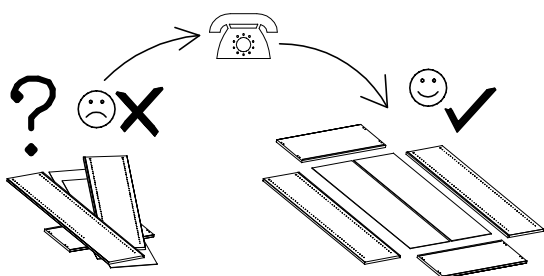
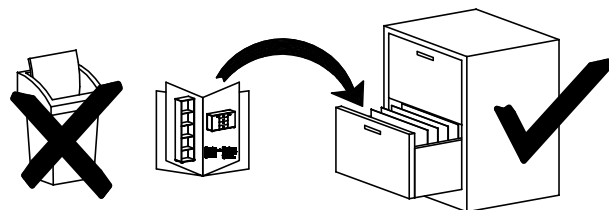
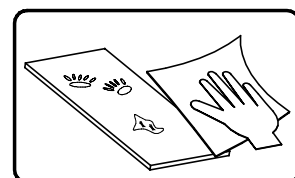
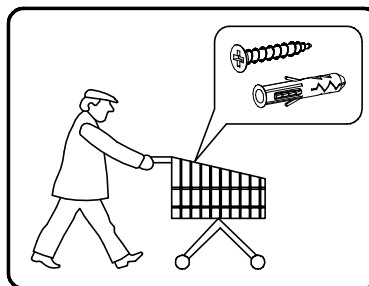
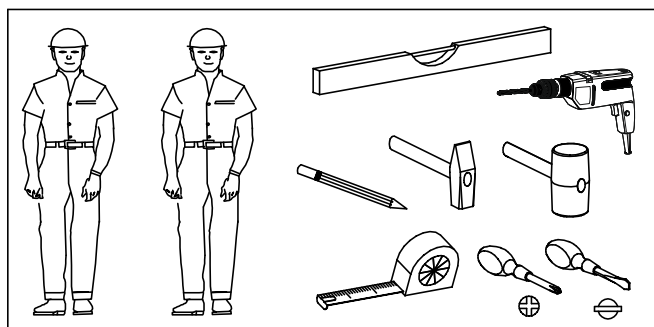

1h

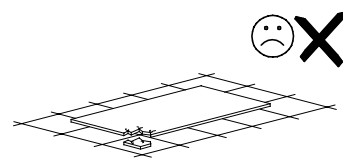
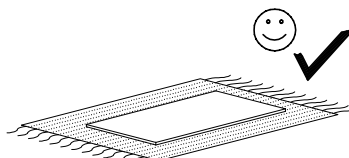



nr	L[mm]	B[mm]	T[mm]	Menge	Colli
1	1187	300	22	1	1/1
2	1187	300	22	1	1/1
3	256	299	22	1	1/1
4	256	299	22	1	1/1
5	256	254	16	2	1/1
6	1135	250	16	1	1/1
7	1151	266	3	1	1/1

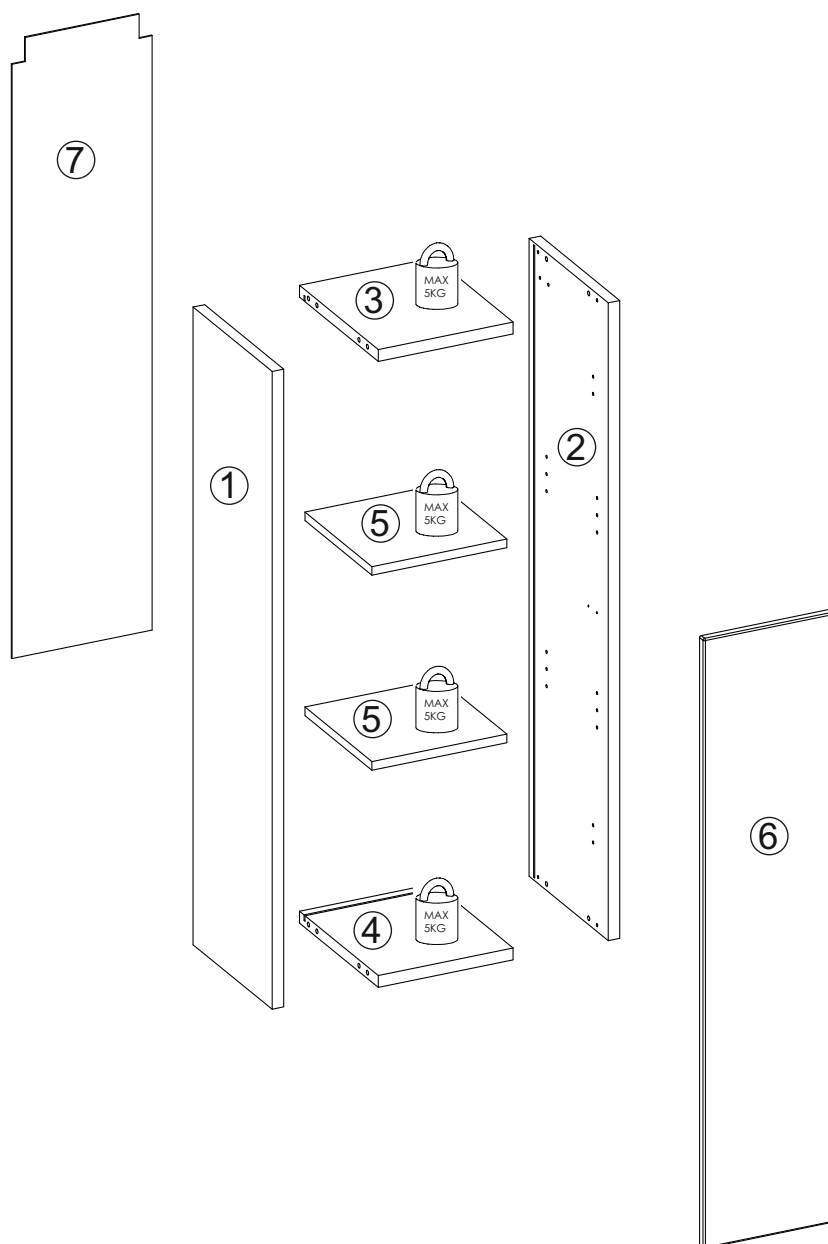

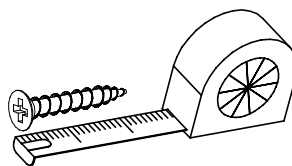
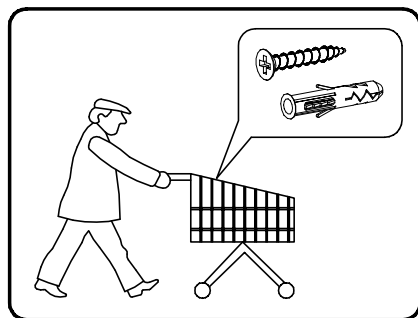
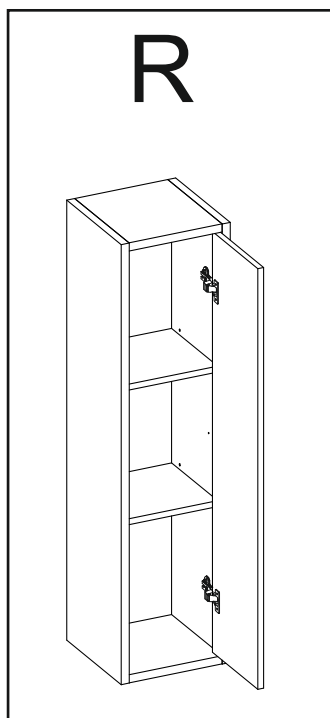
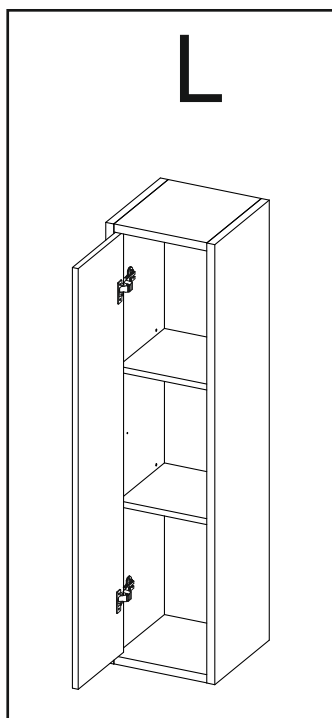

B1 ø8x35 x8	I8 x8	K1 x8	K10 x8	D4 x2
C6 x2	G34 3,5x16 x6	F2 x8	I1 x8	P15 x2
P12 L R x1		P14 x1		G51 x4
F10 x1				

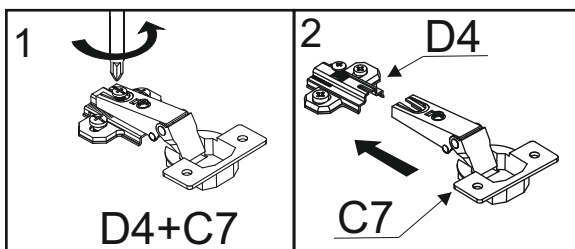

=

D4 x2
C7 x2



I

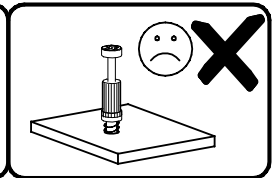
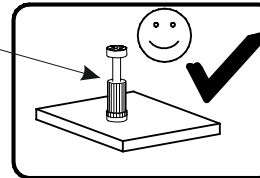
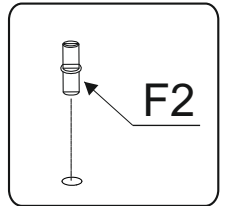
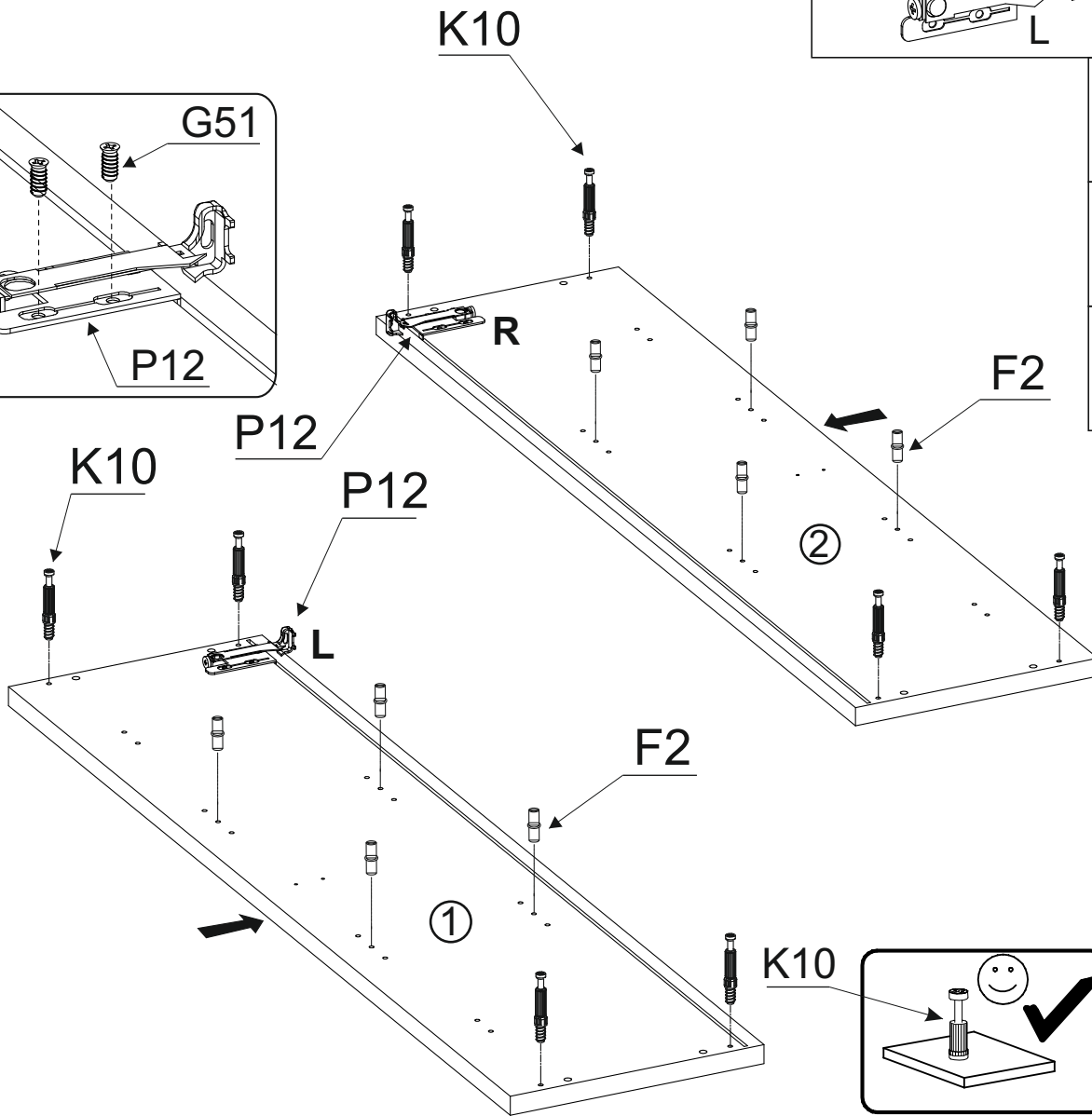
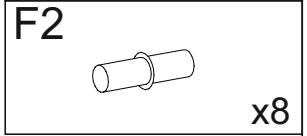
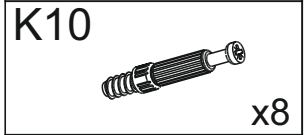
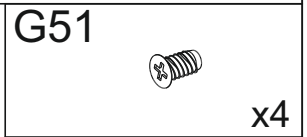
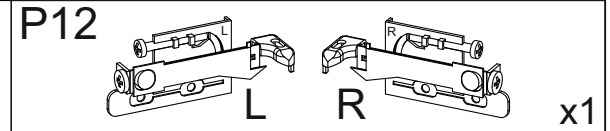
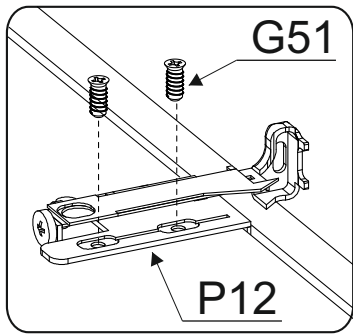

II

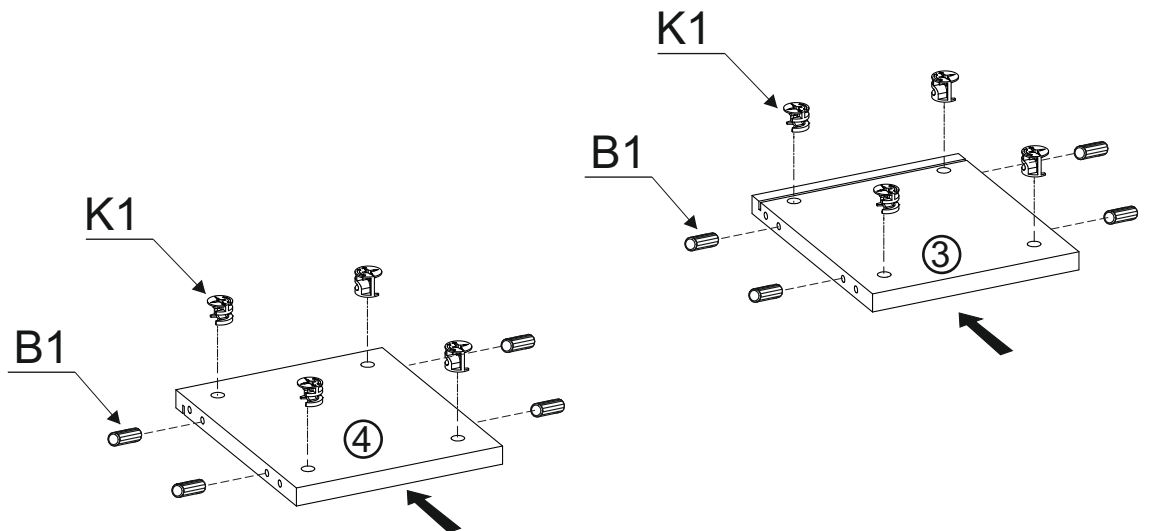
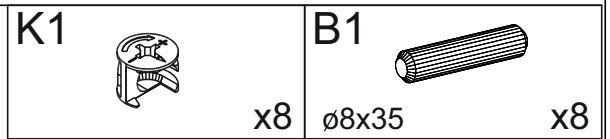
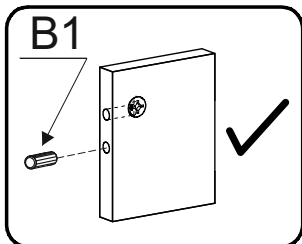
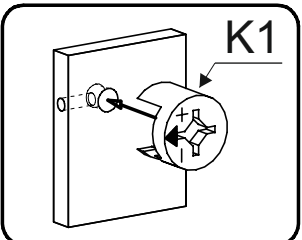



III

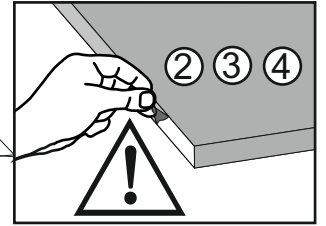
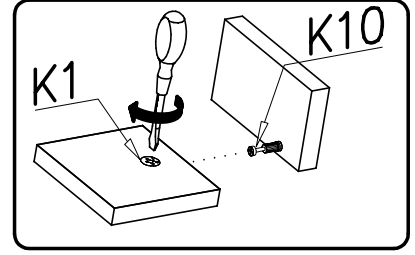
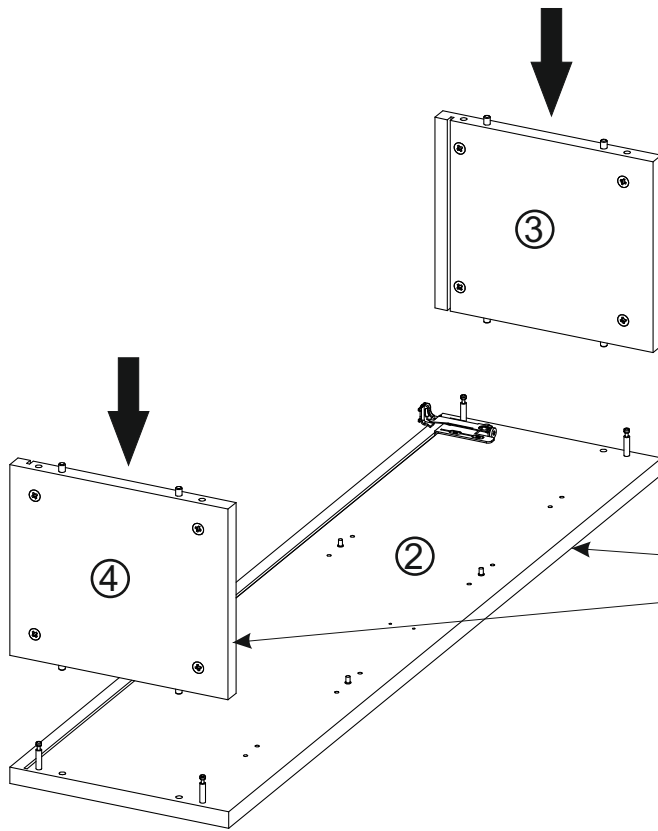

IV

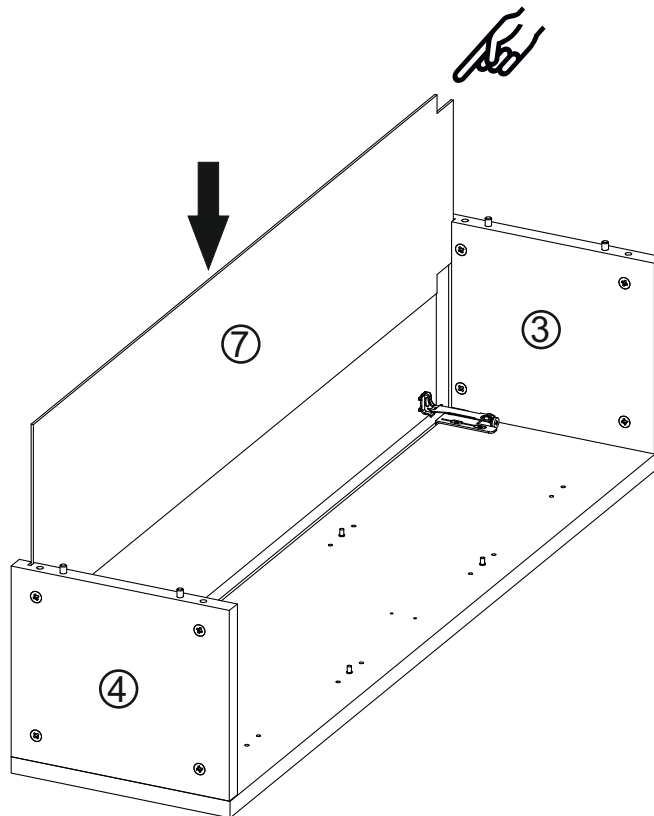



V

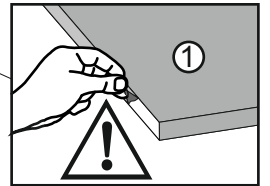
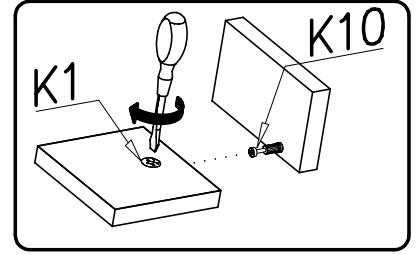
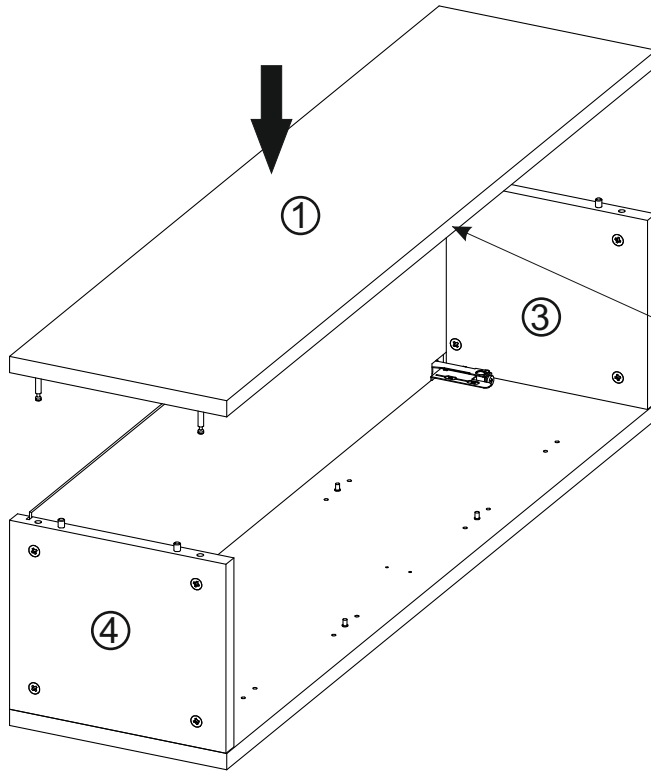

VI

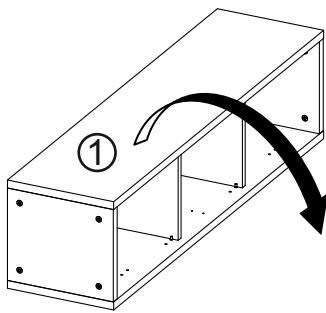

A=B

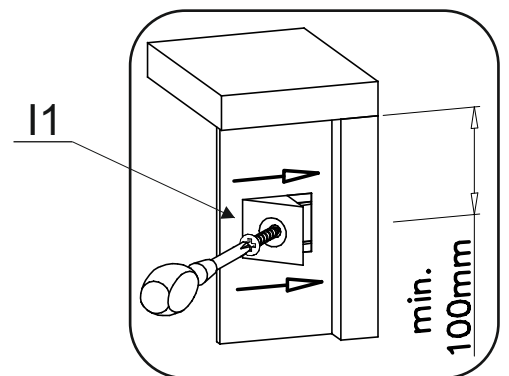
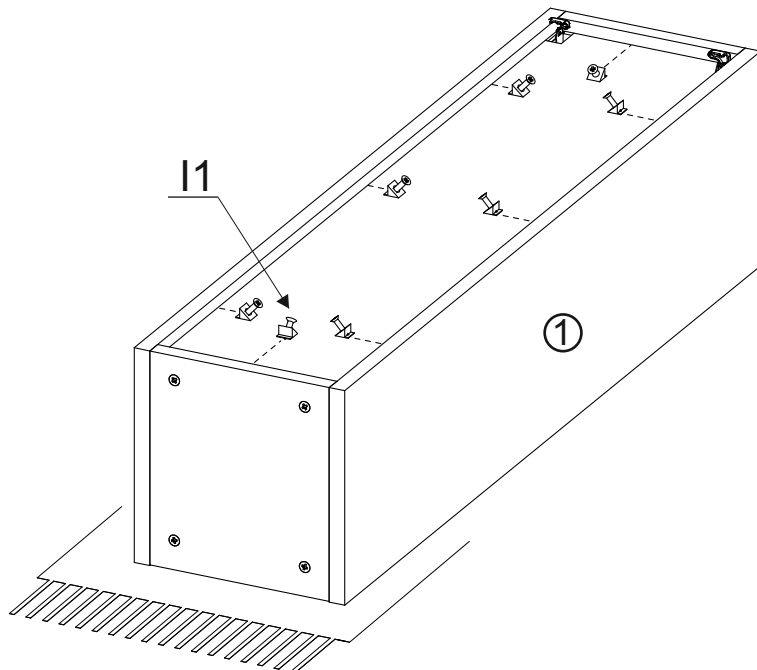
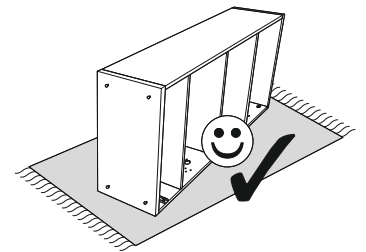
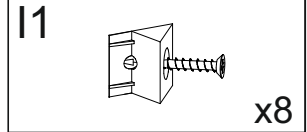
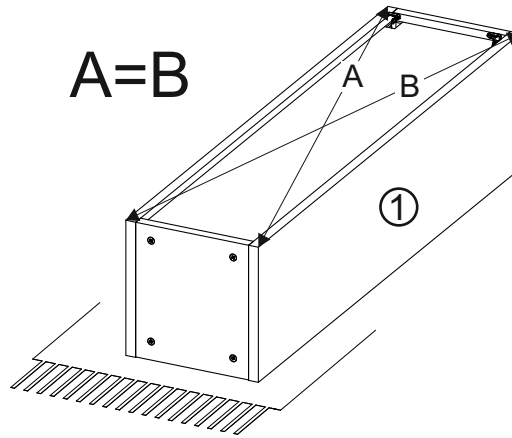



VII

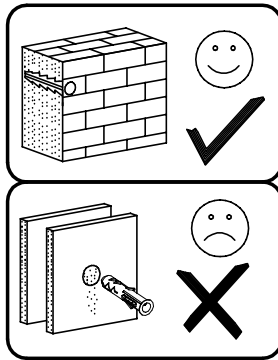
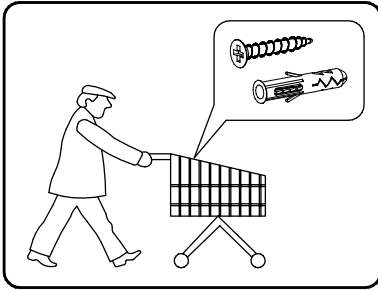

P14

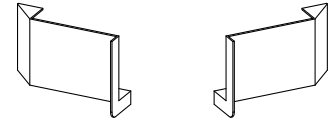

x1

P15

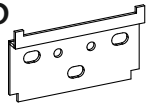

x2

I8



x8

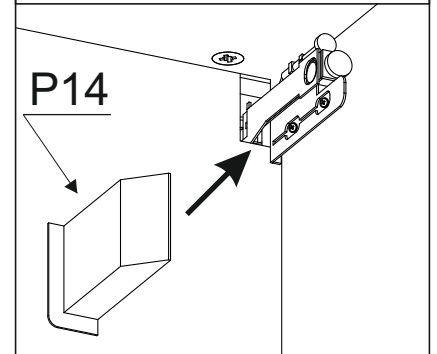
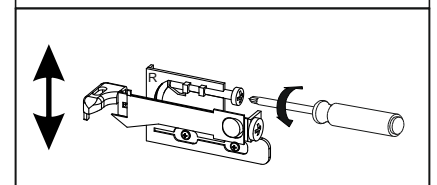
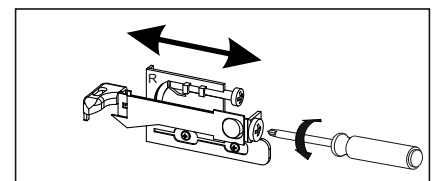
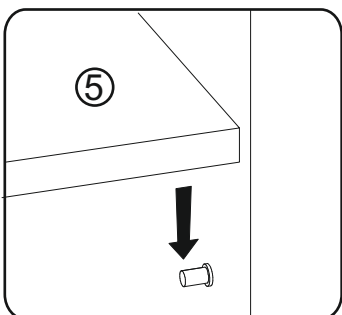
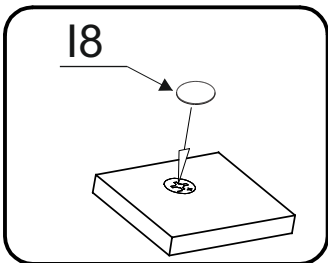
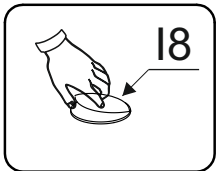
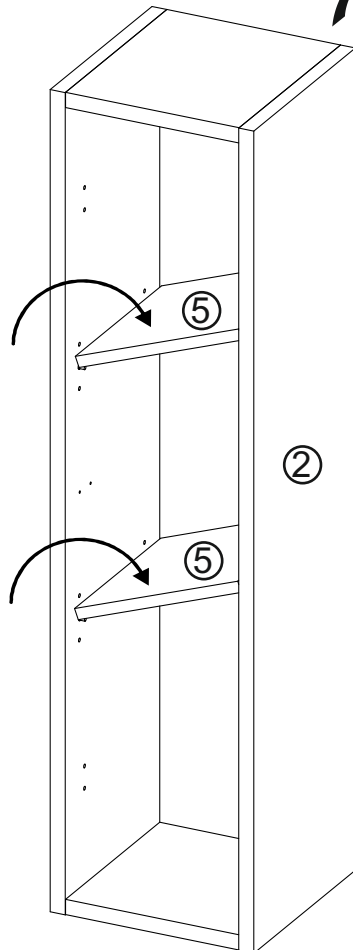
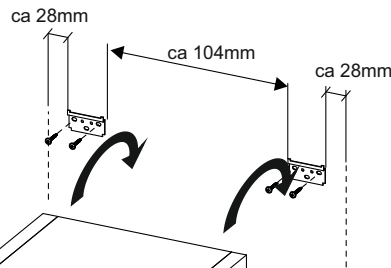
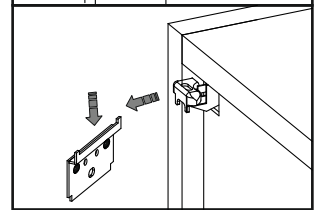
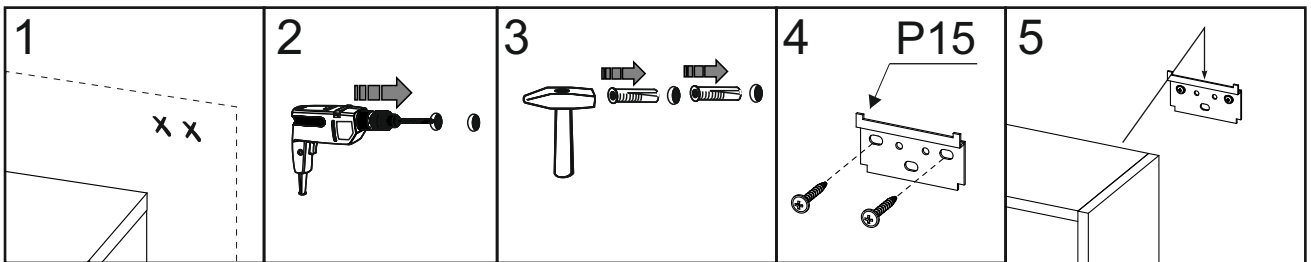



VIII

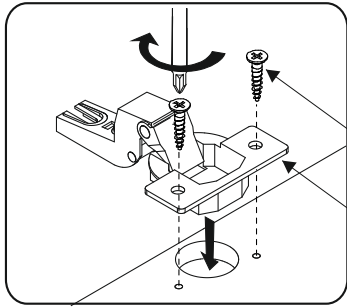

G34

C6

C6

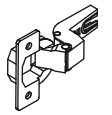

x2

G34



3,5x16

x4

C6

C6

⑥

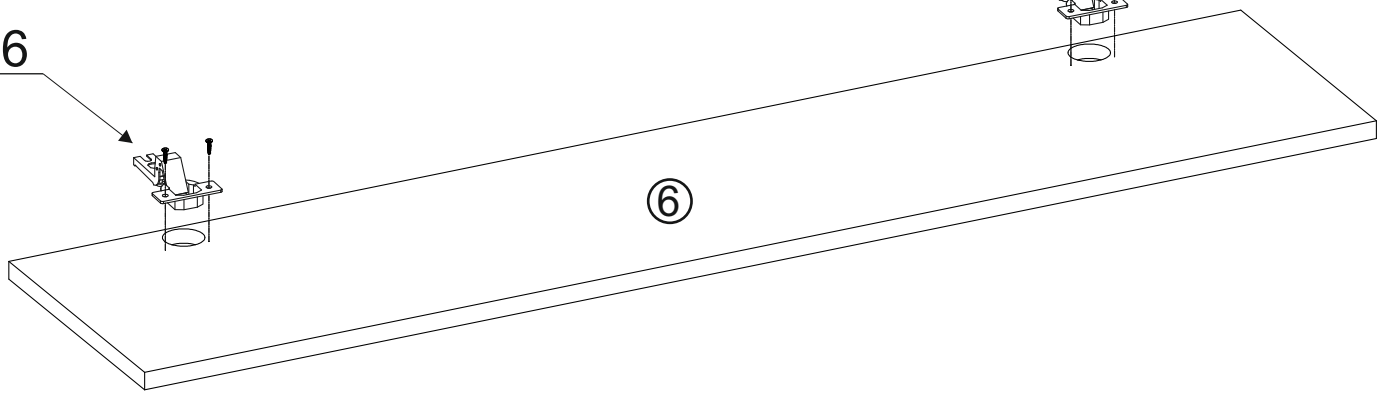



IX

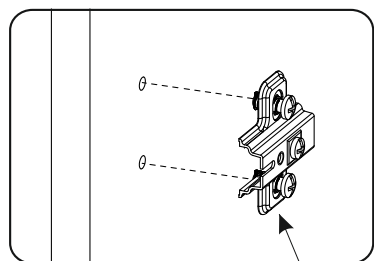
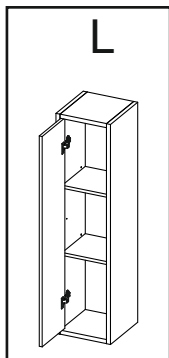

D4

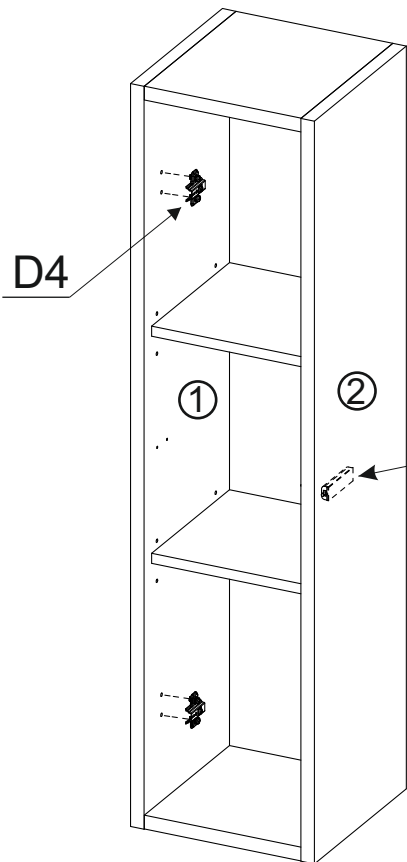

F10



x1

G34



3,5x16

x2

D4



x2

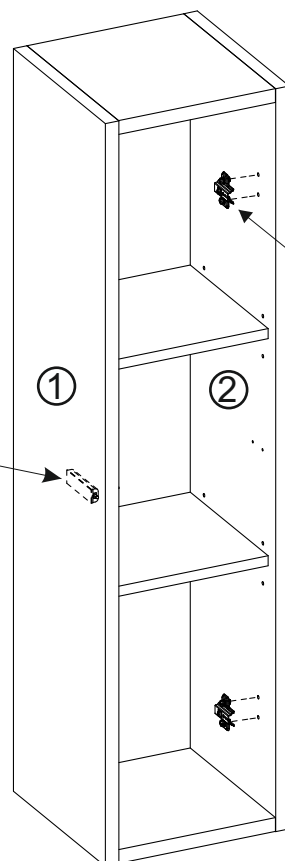
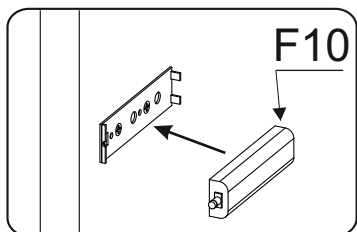
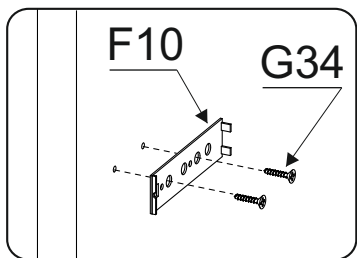
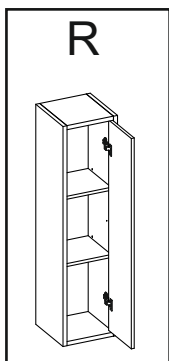
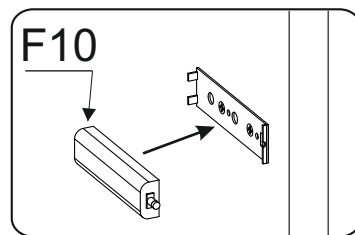
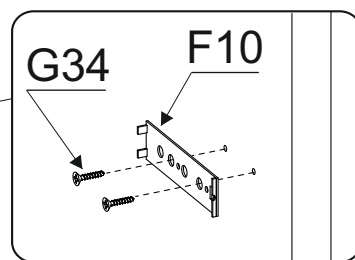

F10



x1

G34



3,5x16

x2

D4



x2



D4

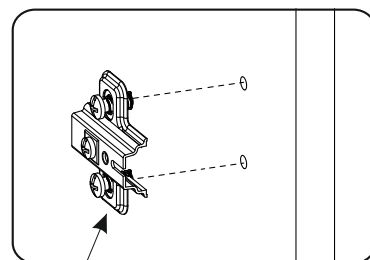

D4



X

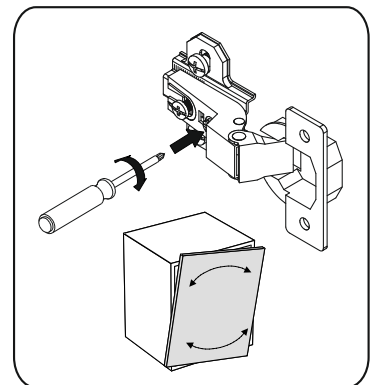
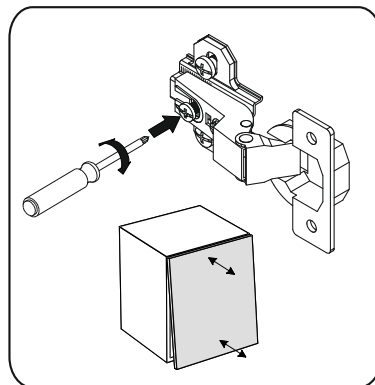
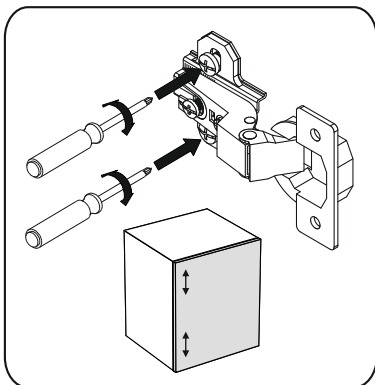
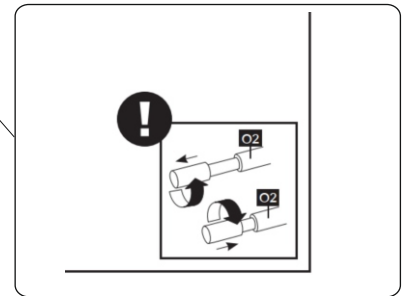
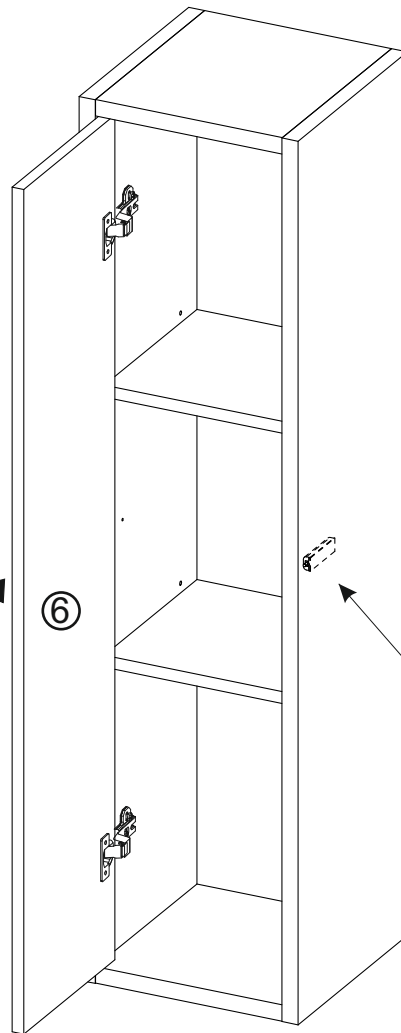
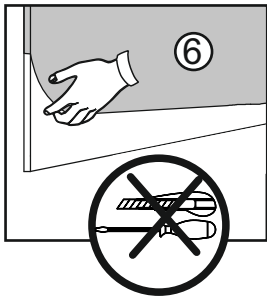
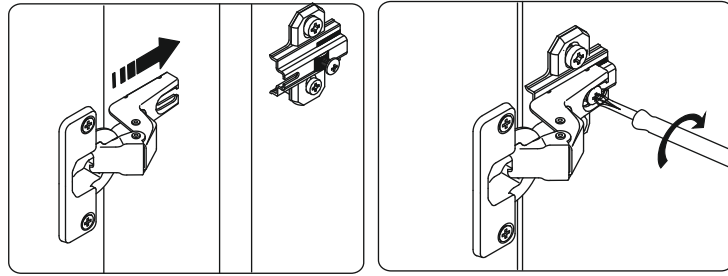
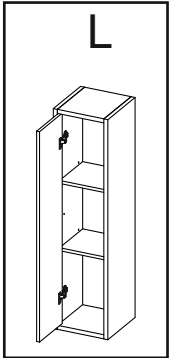



XI

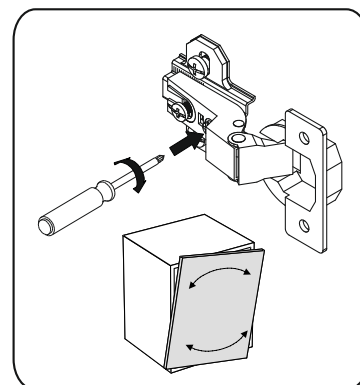
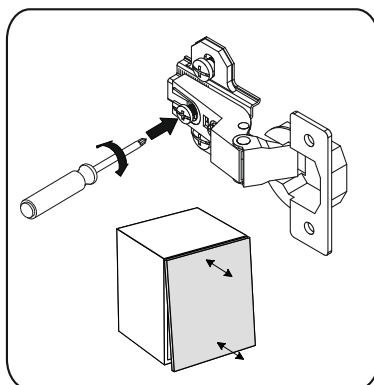
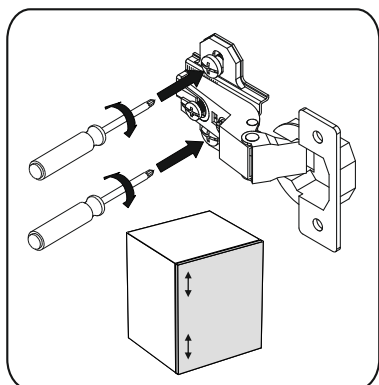
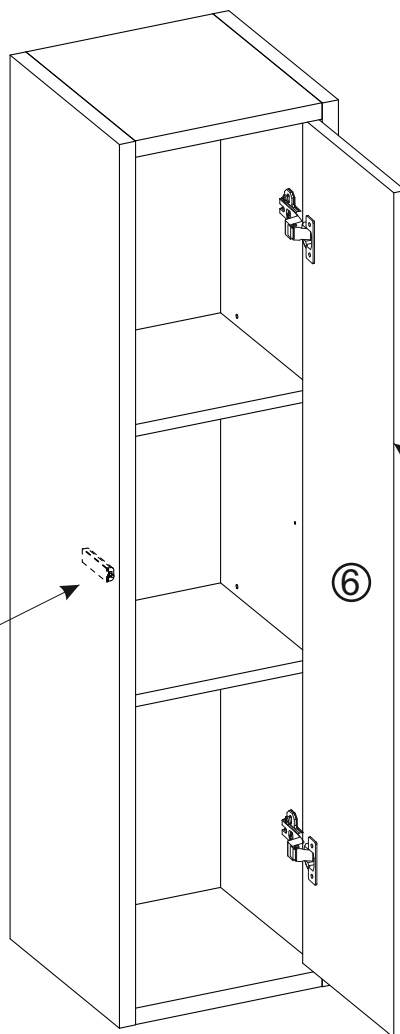
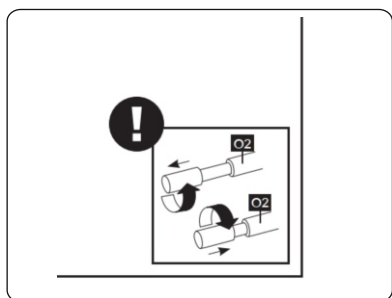
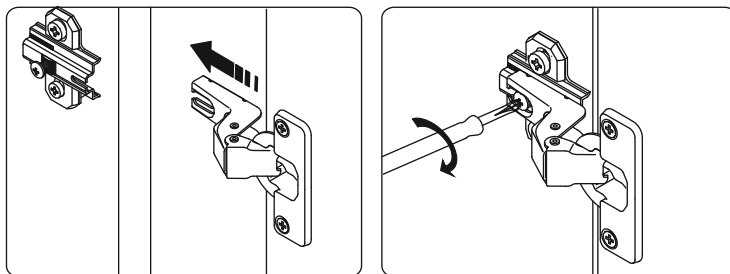
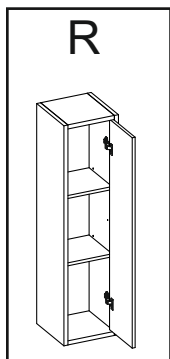

Name • Nom • Nome • Naam • Nazwa • Иméно
• Názov • Név • Denumire • Isim • Извание

Nr • No • N° • Номер • Č • Sz

Typ • Type • Tip • Típus • Tipo • Tun

STUDIO LINE

— —

21

Unser Direktservice für Beschlagteile

Sollte Ihnen ein Beschlagteil fehlen, können Sie diese Servicekarte direkt an die untenstehende Adresse mailen. Wir können allerdings nur Beschlagteile auf diesem Wege verschicken. Sollten Sie eine andere Beanstandung an Ihrem Möbelstück haben, so wenden sie sich bitte direkt an Ihr Möbelhaus.

Our direct order service for fitting

If a fitting part is missing, you can e-mail this service card directly to the address below. However, we can only send fitting parts in this way. If you have any other cause for complaint concerning your item of furniture, please contact your furniture store directly.

Naše přímé služby pro kování

Chybí-li vám nějaký díl z kování, můžete tuto servisní kartu odeslat e-mailem přímo na níže uvedenou adresu. Touto cestou však můžeme zoslat jen díly kování. Pokud byste reklamovali jiný díl nábytku, obraťte se přímo na svého prodejce nábytku.

Bien etudier la notice de montage

S'il vous manque une ferrure, veuillez envoyer directement la présente carte service à l'adresse e-mail indiquée ci-dessous. Cependant, ceci nous permet uniquement d'envoyer des ferrures. Pour tout autre type de réclamation concernant votre meuble, veuillez contacter directement votre magasin d'ameublement.

Il nostro servizio diretto per l'ordine della ferramenta

Qualora Vi dovesse mancare un pezzo di fissaggio, allora Vi preghiamo di inviare questa carta di servizio immediatamente all'indirizzo sottostante. Possiamo inviare i pezzi di fissaggio solamente per mezzo di questo procedimento. Qualora dovete avere qualche altra reclamazione in merito al mobile, allora Vi preghiamo di rivolgerVi direttamente al Vostro Negozio di mobili.

Нашата директна услуга за обков

Ако липсват части от комплекта, попълнете настоящата сервисна карта и ни я изпратете на е-мил адреса, посочен по-долу. По този начин можем да доставяме само липсващи елементи от обкова. Ако установите други дефекти по мебелите, Ви съветваме да се обърнете към мебелната къща/магазин, от който сте закупили стоката.

Onze directservice voor losse onderdelen

Wanneer er een onderdeel ontbreekt, kunt u deze servicekaart direct aan onderstaand e-mailadres sturen. Wij kunnen langs deze weg echter alleen beslagdelen versturen. Mocht u een ander probleem aan uw meubel hebben, verzoeken wij u contact op te nemen met uw meubeldealer.

Nasz bezpośredni serwis części montażowych

Jeżeli brakuje części koniecznych do montażu, prosimy o przesłanie nam niniejszej karty serwisowej na niżej podany adres e-mailowy. W ten sposób możemy przelać Państwu tylko brakujące części. W przypadku innych reklamacji dotyczących mebla, prosimy zgłosić się do salonu meblowego, w którym został dokonany zakup.

Servis za okove

U slučaju da nedostaje neki od dijelova molimo vas da na dolje navedenu mail adresu pošaljete ovaj servisni obrazac. Na ovaj način mogu se dostaviti samo okovi. U slučaju da imate dodatne prigovore vezane uz komad namještaja molimo vas da se obratite izravno trgovini namještaja gdje je isti kupljen.

Direktszolgáltatunk vasalatok esetén

Ha hiányzik egy vasalat, ezt a kártyát közvetlenül elküldheti az alább található címre. Azonban csak vasalatokat tudunk így küldeni. Amennyiben másfajta reklamáció áll fenn bűtorárabját illetően, forduljon közvetlenül a bűtorházhoz.

Náš priamy servis pre časti kovania

Ak by Vám chýbala nejaká časť kovania, môžete poslať túto servisnú kartu poslať e-mailom na nižšie uvedenú adresu. Diely kovania vieme poslať iba týmto spôsobom. Ak by ste mali inú reklamáciu ohľadom Vášho nábytku, obráťte sa priamo na Vašu predajňu nábytku.

Naše direktne uslužne storitve za okovje

Če vam manjka kakšno okovje, lahko to servisno kartico pošljete po e-pošti direktno na spodnji naslov. Po tej poti vam lahko pošljemo samo okovje. Če želite reklamirati kakšen drug del pohištva, se obrnite neposredno na vašo trgovino pohištva.

Service-ul nostru direct pentru feronerie

În cazul în care vă lipsește o piesă de feronerie puteți să trimiteți direct acest card de service prin e-mail la adresa de mai jos. Noi nu putem expedia piese de feronerie decât pe această cale. Dacă aveți o altă reclamație referitoare la piesa de mobilier, atunci vă rugăm să vă adresați direct la magazinul dvs. de mobilă.

Наш прямой сервис для поставок фурнитуры

Если окажется, что Вам не хватает того или иного элемента фурнитуры, Вы можете отправить сервисную карту по факсу непосредственно на нижеприведенный адрес электронной почты. Однако, таким образом мы можем пересылать лишь фурнитуру. Если же у Вас возникнут иные претензии относительно приобретенной мебели, пожалуйста, обращайтесь непосредственно в организацию, осуществившую продажу.

Vår direktservice för beslagsdelar

Om du saknar en beslagsdel kan du skicka detta servicekort direkt till e-postadressen som anges nedan. Tänk på att detta är den enda möjligheten att skicka beslagsdelar till dig. Om du vill reklamera din möbel av en annan anledning måste du kontakta ditt möbelhus direkt.

Nuestro servicio directo para accesorios

Si le falta algún accesorio, puede enviar esta tarjeta de servicio directamente a la siguiente dirección. No obstante, por este método solo podemos enviar accesorios. Si tiene alguna otra objeción sobre su mueble, consulte directamente con su mueblería.

Donatilar için doğrudan servisimiz

Bir donatınız eksikse bu servis kartını doğrudan aşağıda bulunan adrese doğrudan mail yazabilirsiniz. Sadece bu yölla donatıları gönderebiliriz. Mobilyanızda başka şikayetleriniz varsa lütfen doğrudan mobilya satıcınıza danışın.

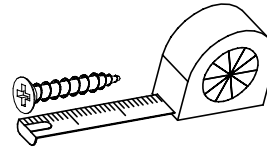

B1 ø8x35 x...	I8 x...	K1 x...
K10 x...	D4 x...	C6 x...
G34 3,5x16 x...	F2 x...	I1 x...
P15 x...	P12 L R x...	
P14 x...	G51 x...	
F10 x...		

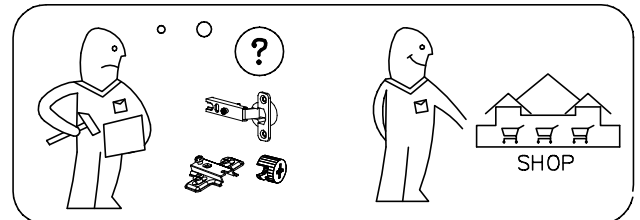
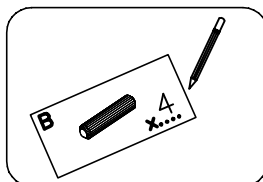

Name • Nom • Nome • Naam • Nazwa • Иméно
• Názov • Név • Denumire • Isim • Извание

Nr • No • N° • Номер • Č • Sz

Typ • Type • Tip • Típus • Tipo • Tun

STUDIO LINE

— —

21

Unser Direktservice für Beschlagteile

Sollte Ihnen ein Beschlagteil fehlen, können Sie diese Servicekarte direkt an die untenstehende Adresse mailen. Wir können allerdings nur Beschlagteile auf diesem Wege verschicken. Sollten Sie eine andere Beanstandung an Ihrem Möbelstück haben, so wenden Sie sich bitte direkt an Ihr Möbelhaus.

Our direct order service for fitting

If a fitting part is missing, you can e-mail this service card directly to the address below. However, we can only send fitting parts in this way. If you have any other cause for complaint concerning your item of furniture, please contact your furniture store directly.

Naše přímé služby pro kování

Chybí-li vám nějaký díl z kování, můžete tuto servisní kartu odeslat e-mailem přímo na níže uvedenou adresu. Touto cestou však můžeme rozesílat jen díly kování. Pokud byste reklamovali jiný díl nábytku, obraťte se přímo na svého prodejce nábytku.

Bien etudier la notice de montage

S'il vous manque une ferrure, veuillez envoyer directement la présente carte service à l'adresse e-mail indiquée ci-dessous. Cependant, ceci nous permet uniquement d'envoyer des ferrures. Pour tout autre type de réclamation concernant votre meuble, veuillez contacter directement votre magasin d'ameublement.

Il nostro servizio diretto per l'ordine della ferramenta

Qualora Vi dovesse mancare un pezzo di fissaggio, allora Vi preghiamo di inviare questa carta di servizio immediatamente all'indirizzo sottostante. Possiamo inviare i pezzi di fissaggio solamente per mezzo di questo procedimento. Qualora dovete avere qualche altra reclamazione in merito al mobile, allora Vi preghiamo di rivolgerVi direttamente al Vostro Negozio di mobili.

Нашата директна услуга за обков

Ако липсват части от комплекта, попълнете настоящата сервисна карта и ни я изпратете на е-mail адреса, посочен по-долу. По този начин можем да доставяме само липсващи елементи от обкова. Ако установите други дефекти по мебелите, Ви съветваме да се обърнете към мебелната къща/магазин, от който сте закупили стоката.

Onze directservice voor losse onderdelen

Wanneer er een onderdeel ontbreekt, kunt u deze servicekaart direct aan onderstaand e-mailadres sturen. Wij kunnen langs deze weg echter alleen beslagdelen versturen. Mocht u een ander probleem aan uw meubel hebben, verzoeken wij u contact op te nemen met uw meubeldealer.

Nasz bezpośredni serwis części montazowych

Jeżeli brakuje części koniecznych do montażu, prosimy o przesłanie nam niniejszej karty serwisowej na niżej podany adres e-mailowy. W ten sposób możemy przesłać Państwu tylko brakujące części. W przypadku innych reklamacji dotyczących mebla, prosimy zgłosić się do salonu meblowego, w którym został dokonany zakup.

Servis za okove

U slučaju da nedostaje neki od dijelova molimo vas da na dolje navedenu mail adresu pošaljete ovaj servisni obrazac. Na ovaj način mogu se dostaviti samo okovi. U slučaju da imate dodatne prigovore vezane uz komad namještaja molimo vas da se obratite izravno trgovini namještaja gdje je isti kupljen.

Direktszolgalatunk vasalatok esetén

Ha hiányzik egy vasalat, ezt a kártyát közvetlenül elküldheti az alább található címre. Azonban csakis vasalatokat tudunk így küldeni. Amennyiben másfajta reklamáció áll fenn bútordarabját illetően, forduljon közvetlenül a bútornához.

Náš priamy servis pre časti kovania

Ak by Vám chýbala nejaká časť kovania, môžete poslať túto servisnú kartu poslať e-mailom na nižšie uvedenú adresu. Diely kovania vieme poslať iba týmto spôsobom. Ak by ste mali inú reklamáciu ohľadom Vášho nábytku, obráťte sa priamo na Vašu predajňu nábytku.

Naše direktne uslužne storitve za okovje

Če vam manjka kakšno okovje, lahko to servisno kartico pošljete po e-pošti direktno na spodnji naslov. Po tej poti vam lahko pošljemo samo okovje. Če želite reklamirati kakšen drug del pohištva, se obrnite neposredno na vašo trgovino pohištva.

Service-ul nostru direct pentru feronerie

În cazul în care vă lipsește o piesă de feronerie puteți să trimiteți direct acest card de service prin e-mail la adresa de mai jos. Noi nu putem expedia piese de feronerie decât pe această cale. Dacă aveți o altă reclamație referitoare la piesa de mobilier, atunci vă rugăm să vă adresați direct la magazinul dvs. de mobilă.

Наш прямой сервис для поставок фурнитуры

Если окажется, что Вам не хватает того или иного элемента фурнитуры, Вы можете отправить сервисную карту по факсу непосредственно на нижеприведенный адрес электронной почты. Однако, таким образом мы можем пересылать лишь фурнитуру. Если же у Вас возникнут иные претензии относительно приобретенной мебели, пожалуйста, обращайтесь непосредственно в организацию, осуществившую продажу.

Vår direktservice för beslagsdelar

Om du saknar en beslagsdel kan du skicka detta servicekort direkt till e-postadressen som anges nedan. Tänk på att detta är den enda möjligheten att skicka beslagsdelar till dig. Om du vill reklamera din möbel av en annan anledning måste du kontakta ditt möbelhus direkt.

Nuestro servicio directo para accesorios

Si le falta algún accesorio, puede enviar esta tarjeta de servicio directamente a la siguiente dirección. No obstante, por este método solo podemos enviar accesorios. Si tiene alguna otra objeción sobre su mueble, consulte directamente con su mueblería.

Donatilar için doğrudan servisimiz

Bir donatınız eksikse bu servis kartını doğrudan aşağıda bulunan adrese doğrudan mail yazabilirsiniz. Sadece bu yolla donatıları gönderebiliriz. Mobilyanızda başka şikayetleriniz varsa lütfen doğrudan mobilya satıcınıza danışın.

nr	L[mm]	B[mm]	T[mm]	Menge	Colli
1	1187	300	22	1	1/1
2	1187	300	22	1	1/1
3	256	299	22	1	1/1
4	256	299	22	1	1/1
5	256	254	16	2	1/1
6	1135	250	16	1	1/1
7	1151	266	3	1	1/1

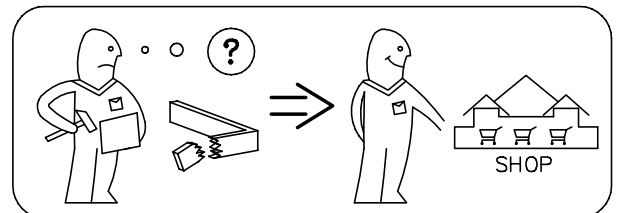
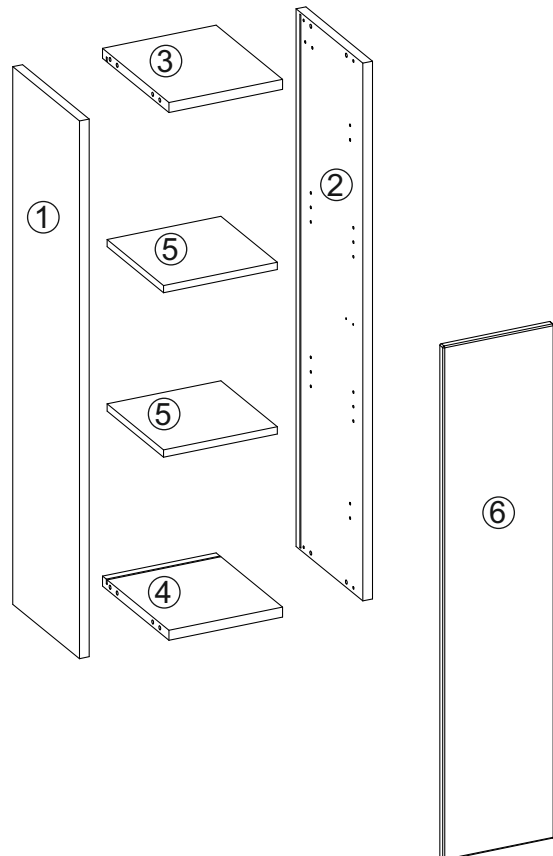
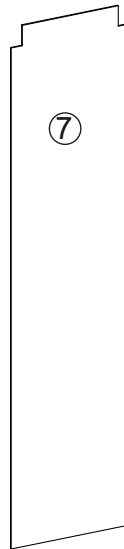

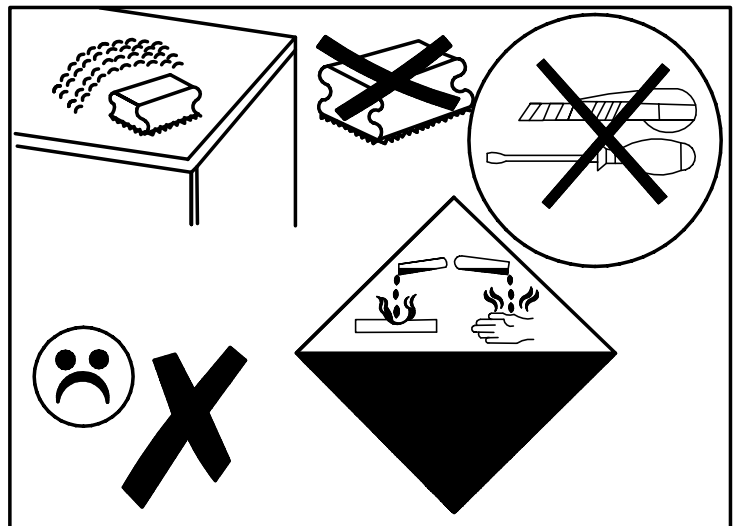
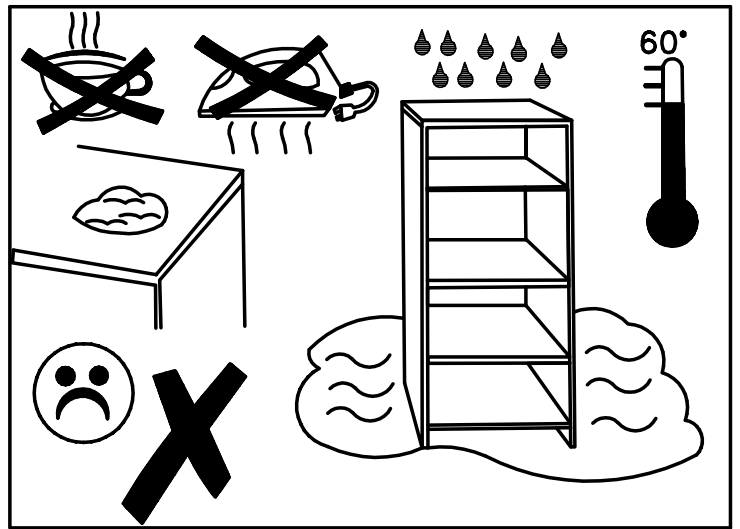
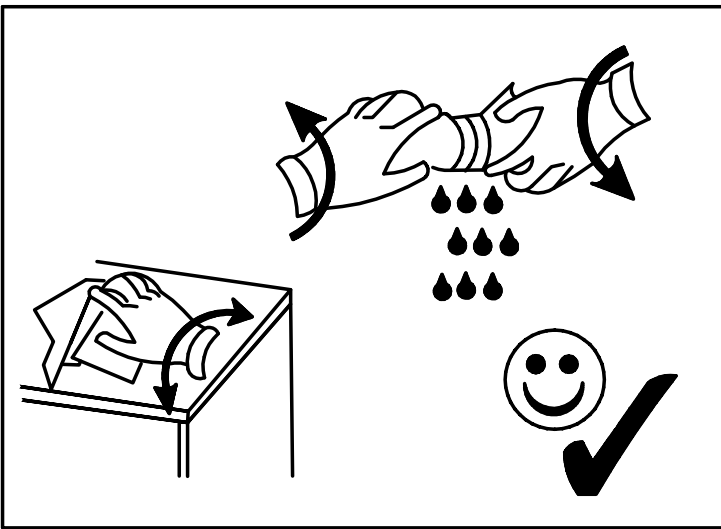
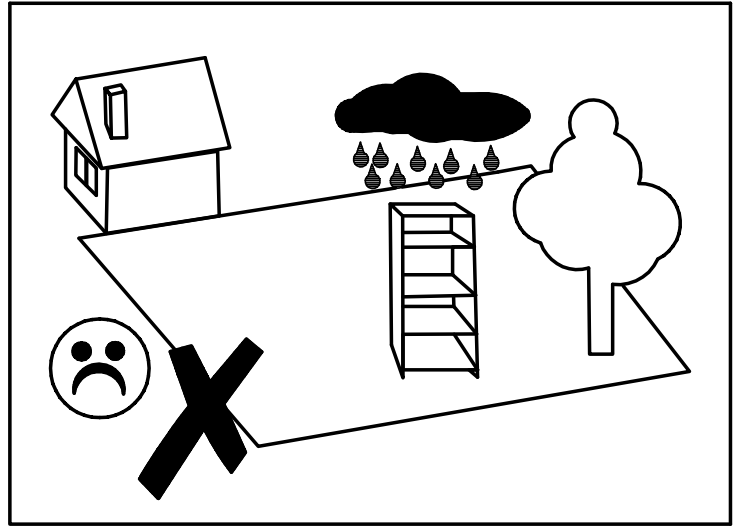
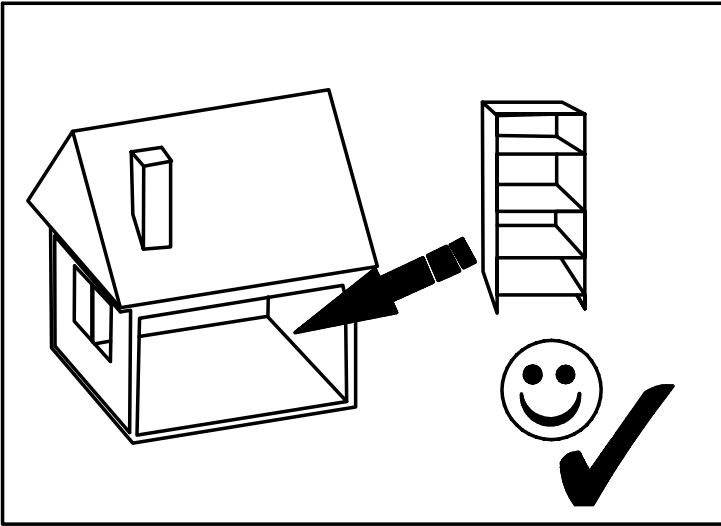

Modell: STUDIO LINE 23

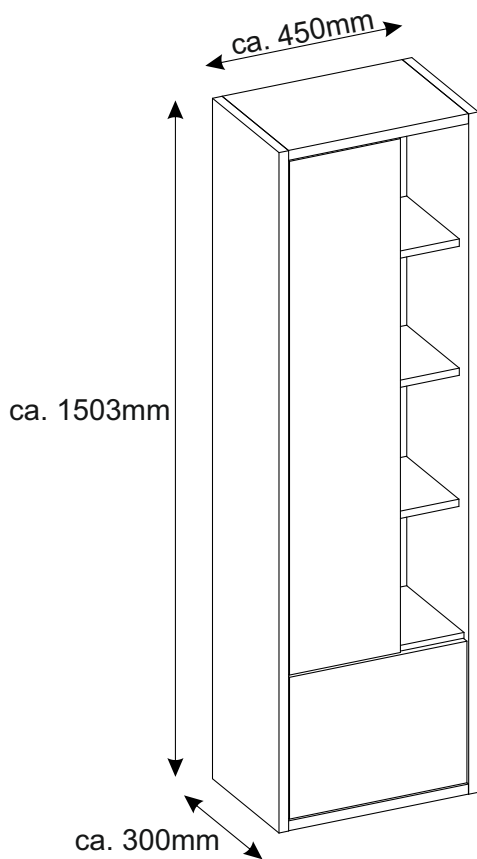

- Ⓛ Montageanleitung
- ⓃL Handleiding voor de montage
- ⓂR Montaj talimati
- ⓕ Notice de montage
- ⒸZ Montážní návod
- ⓂU Szerelési útmutató
- ⓖB Assembly instructions
- ⓅL Instrukcja montażu
- ⓇU Инструкция по монтажу
- ⓂT Istruzioni di montaggio
- ⓂK Návod na montáž
- ⓇO Instrucțiuni de montaj
- ⓔS Instrucciones de montaje
- ⓂR Montaj Talimati

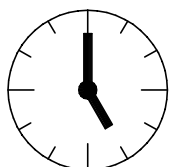
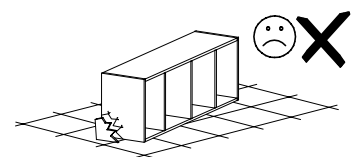
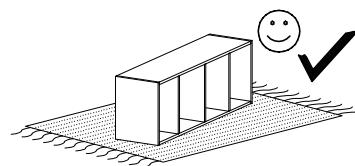
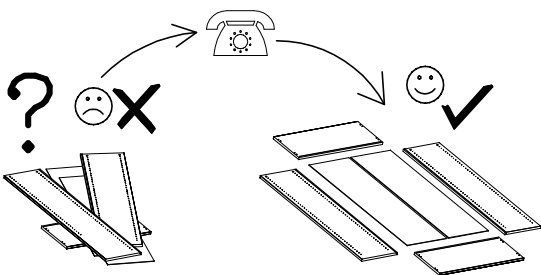
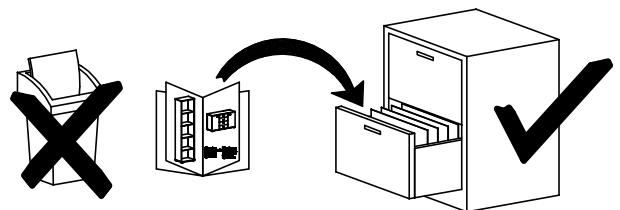
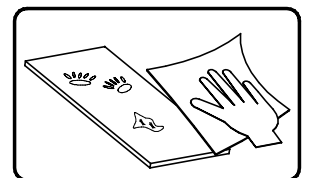
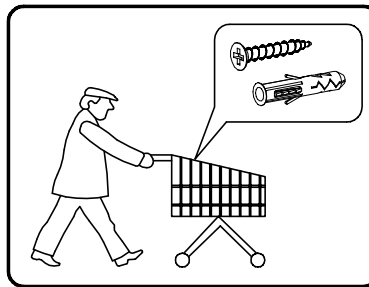
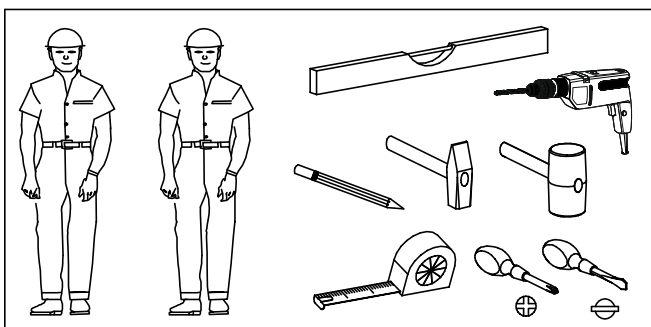

1,5h

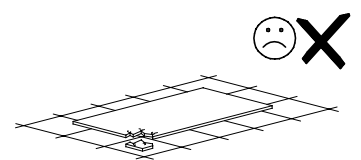
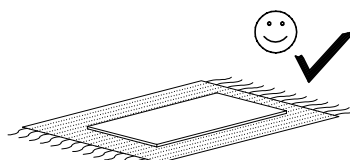



nr	L[mm]	B[mm]	T[mm]	Menge	Colli
1	1503	300	22	1	1/1
2	1134	257	16	1	1/1
3	1503	300	22	1	1/1
4	406	299	22	1	1/1
5	406	258	16	1	1/1
6	406	299	22	1	1/1
7	252	241	16	3	1/1

nr	L[mm]	B[mm]	T[mm]	Menge	Colli
8	237	149	16	3	1/1
9	1135	250	16	1	1/1
10	313	400	16	1	1/1
11	1146	253	3	1	1/1
12	1146	162	3	1	1/1
13	416	321	3	1	1/1

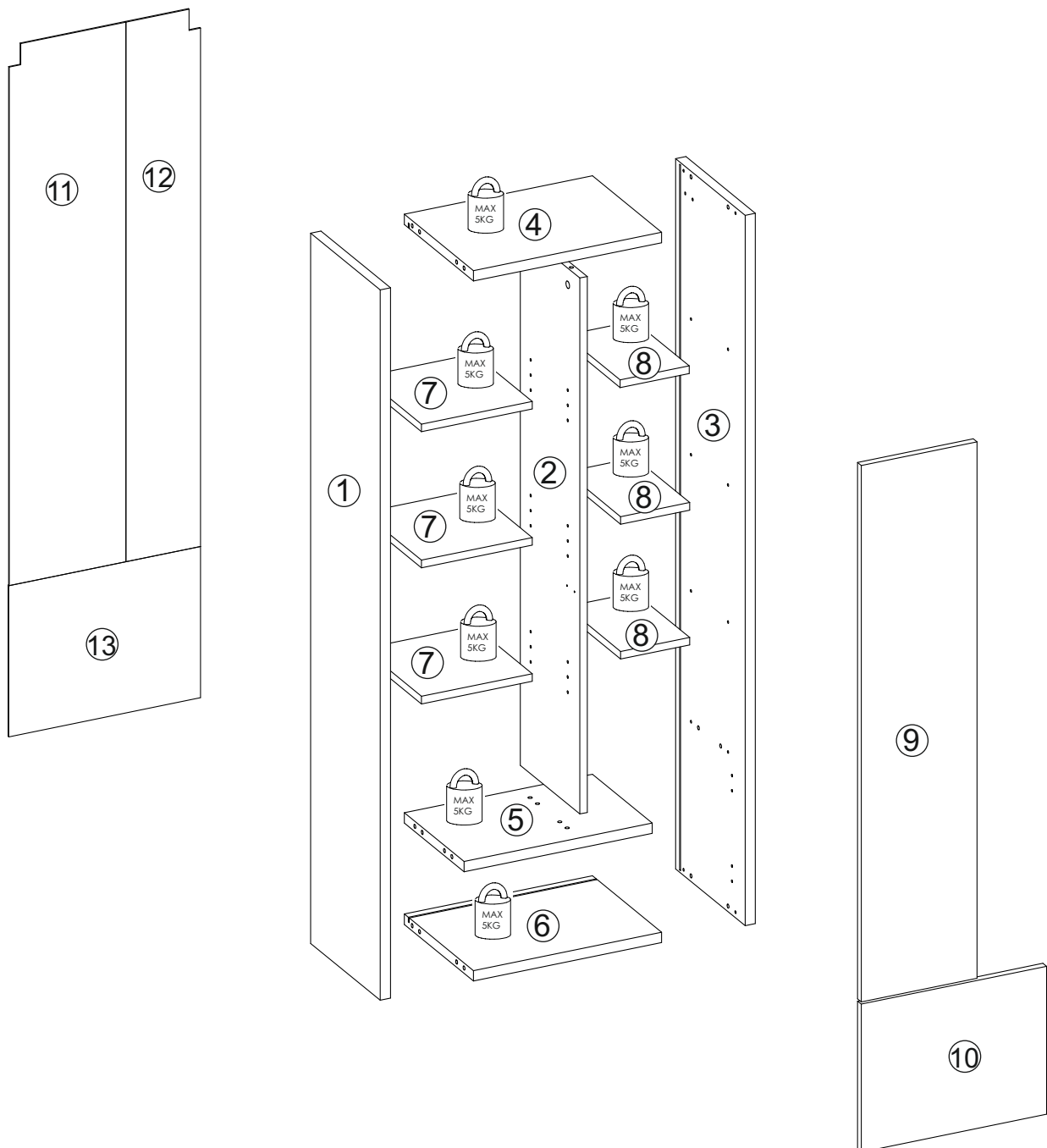

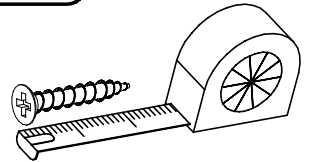
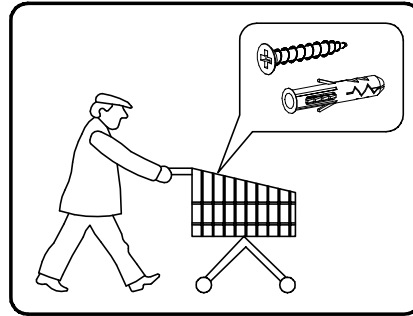
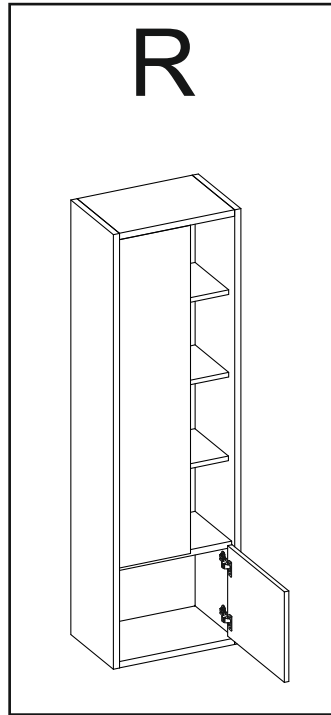
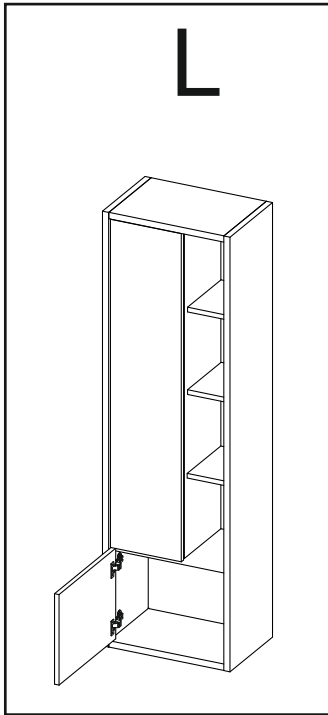

B1 ø8x35 x16	I8 x18	K1 x14	K10 x14	D4 x4
C6 x4	G34 3,5x16 x12	F2 x24	I1 x8	P15 x2
P12 L	P12 R x1	P14 x1	G51 x4	
F10 x2	A1 ø7x50 x2	W2 x1	G50 3x20 x10	
Z6 x10				

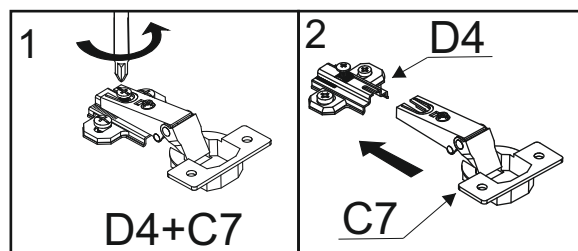

=

D4 x4
C7 x4

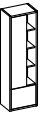

I

P12

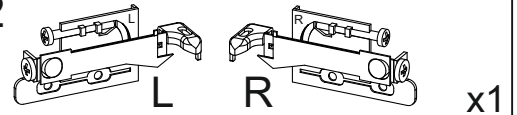

G51



K10

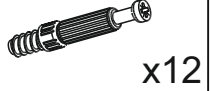

F2

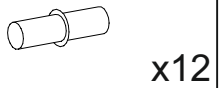

D4

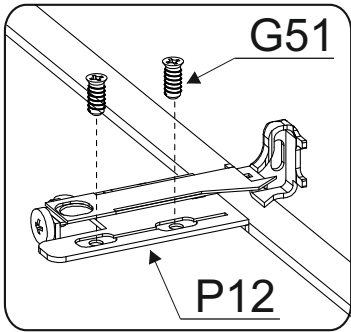
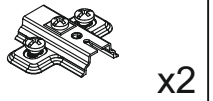

K10

P12

F2

③

P12

①

D4

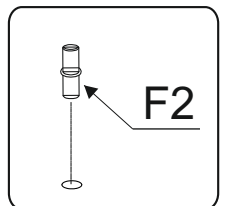
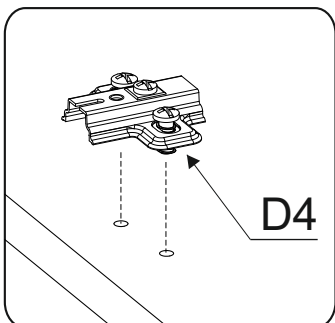
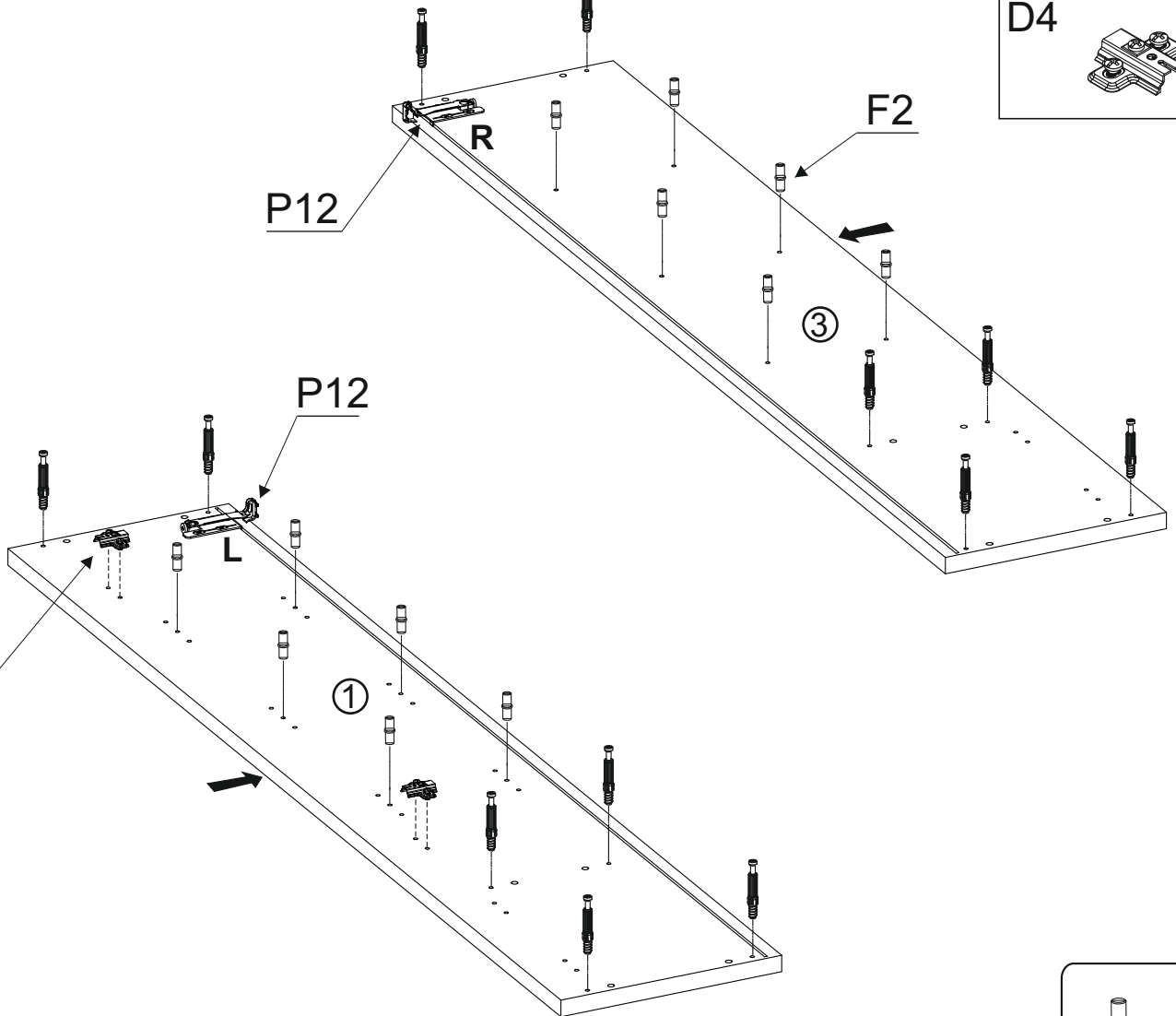

K10

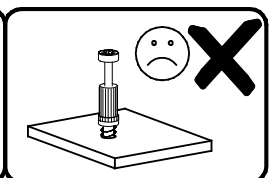
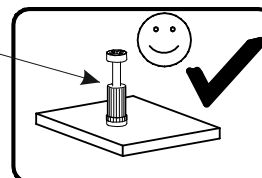

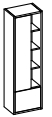

II

G34



3,5x16

x2

F10

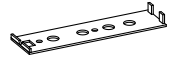
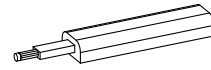

x1

B1

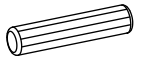

ø8x35

x4

K1



x2

F2

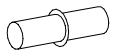

x12

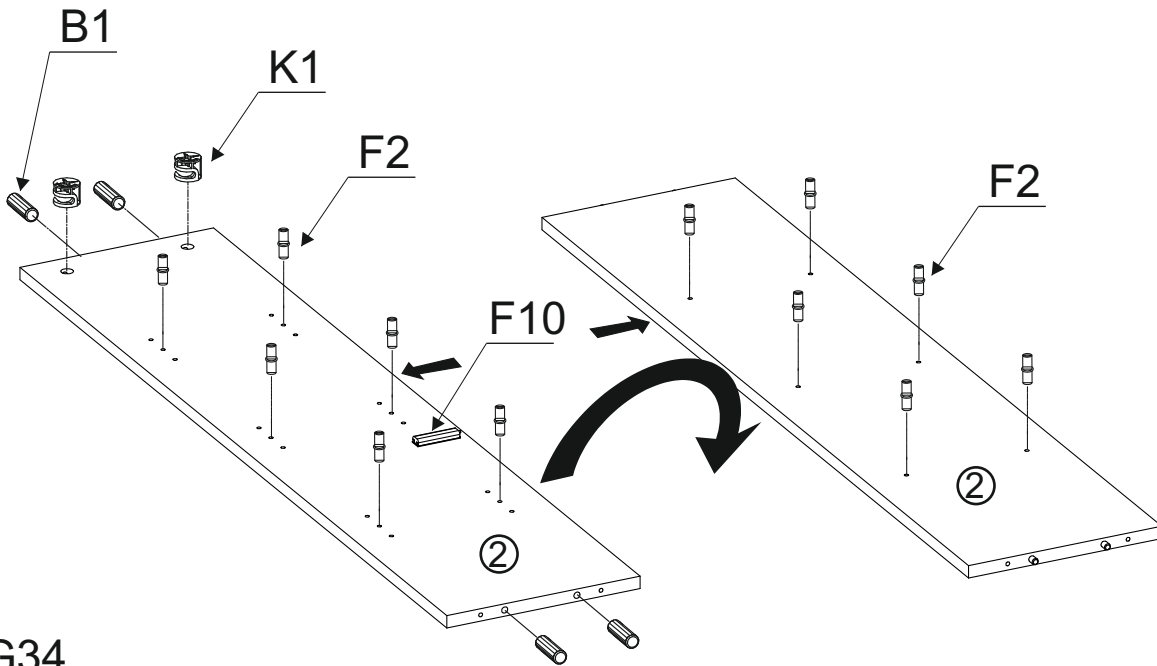

G34

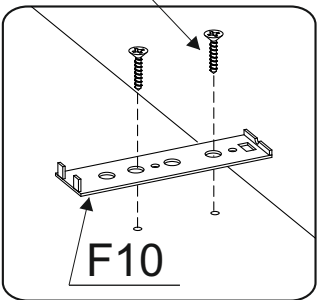

F10

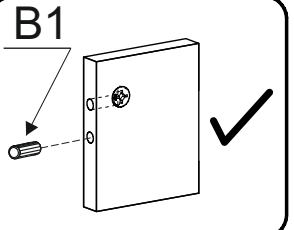
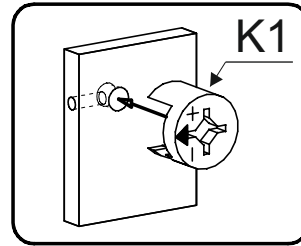
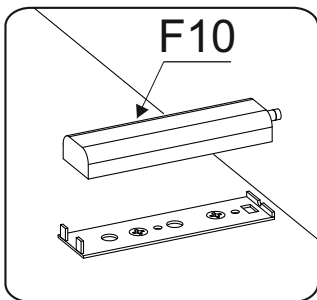

III

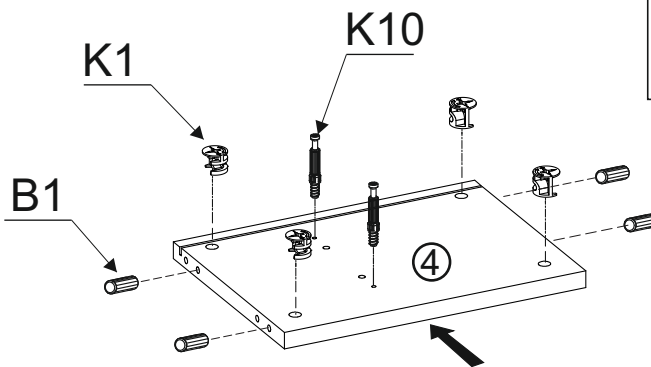

K10



x2

B1



ø8x35

x12

K1



x12

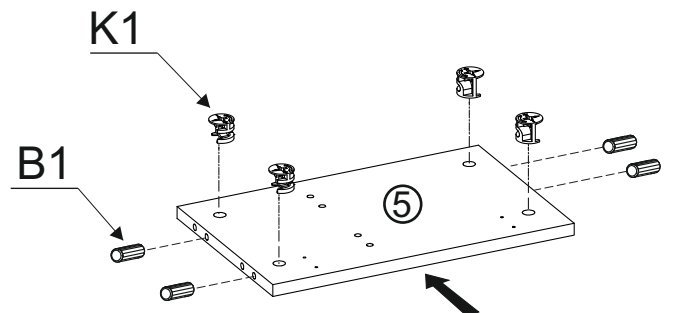
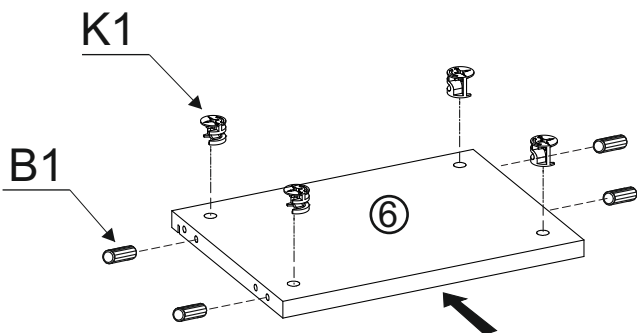

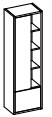

IV

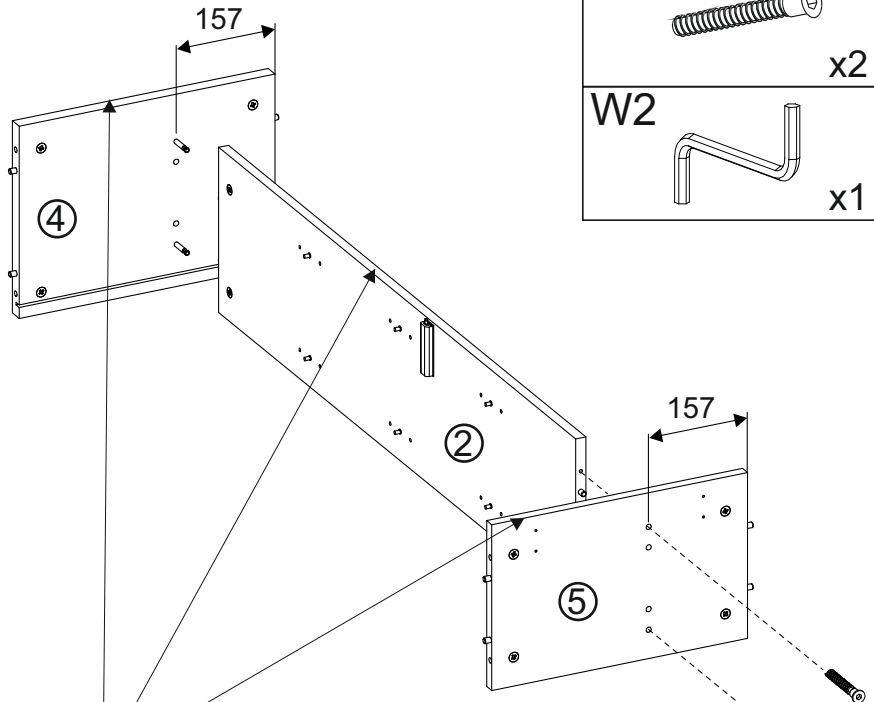
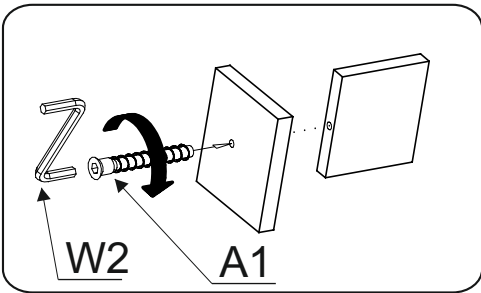
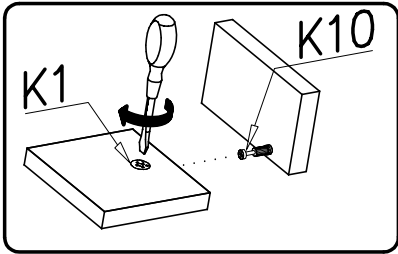

- A1 x2
- W2 x1

2 4 5

24 H

V

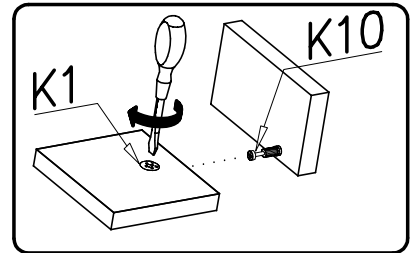
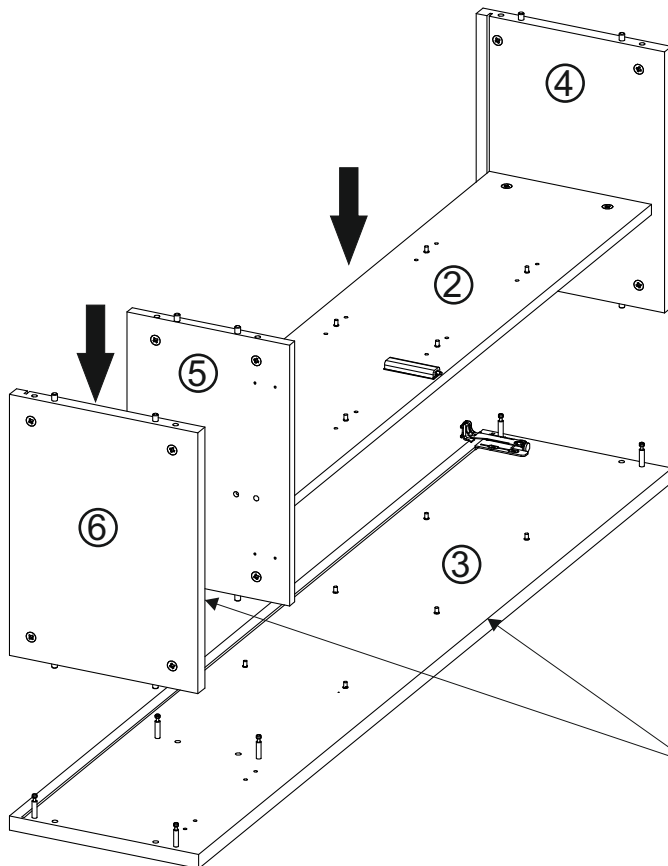

3 6

24 H

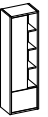

VI

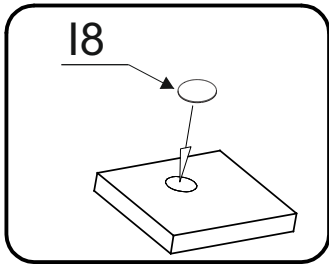
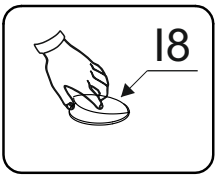
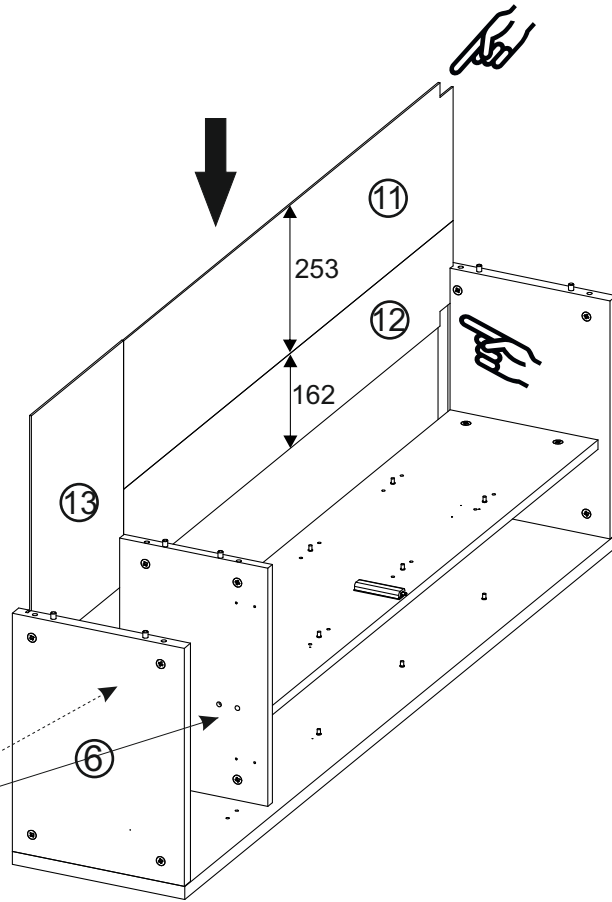
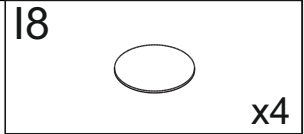

VII

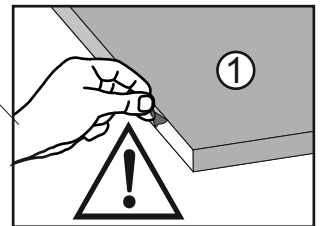
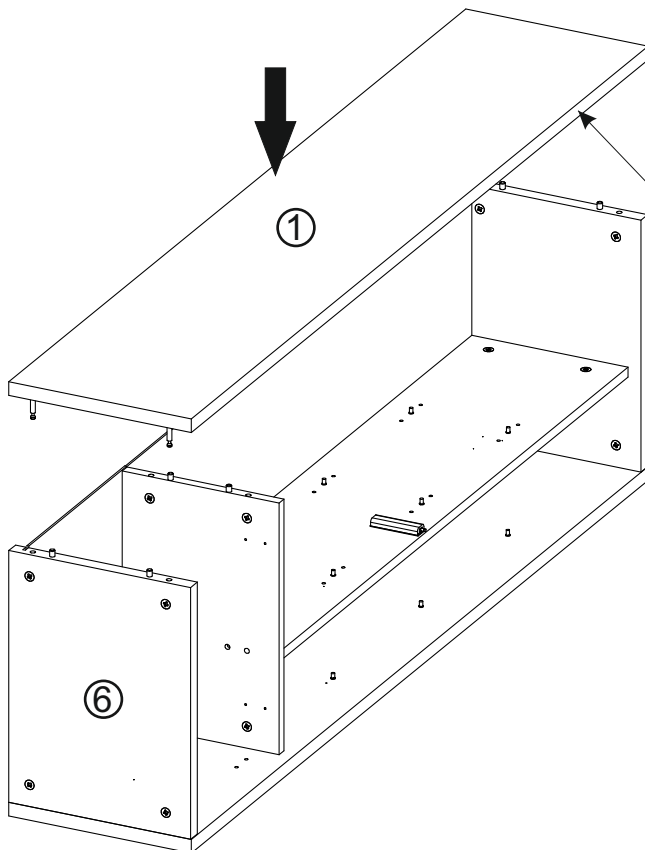
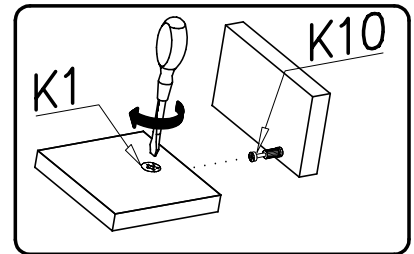

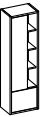

VIII

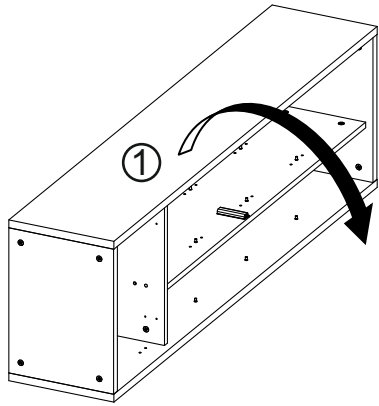

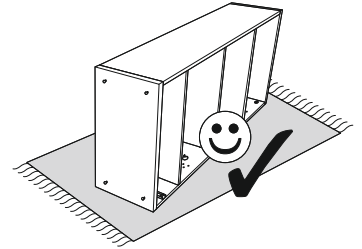
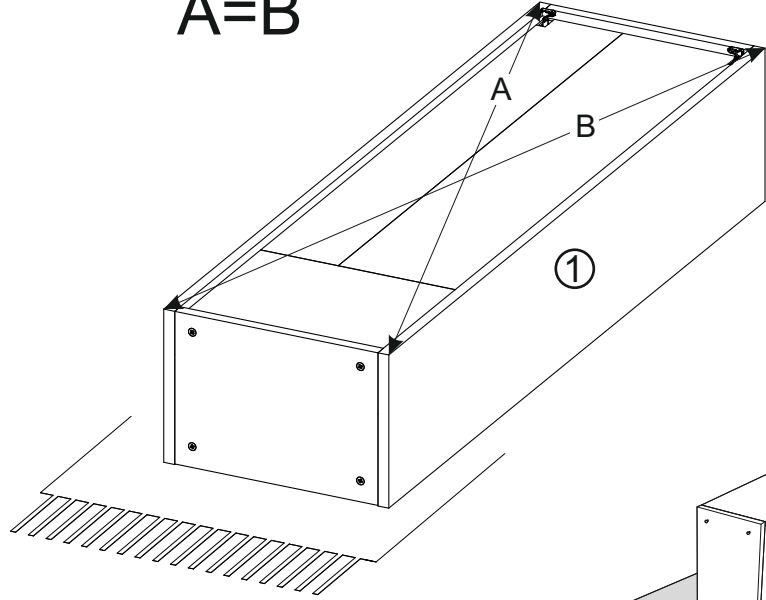

A=B

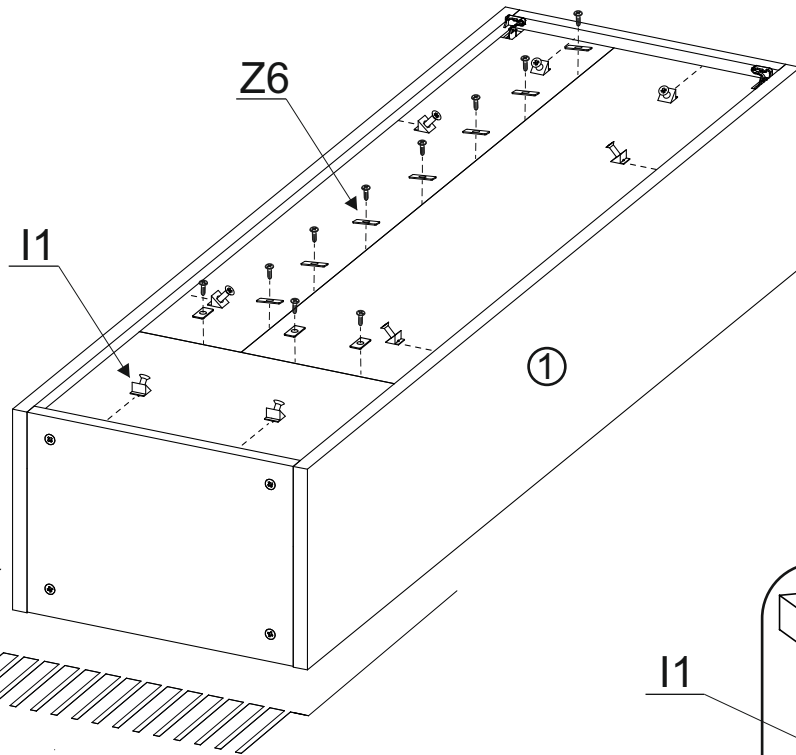

IX

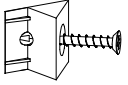
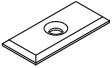

- I1  x8
- Z6  x10
- G50  x10
3x20

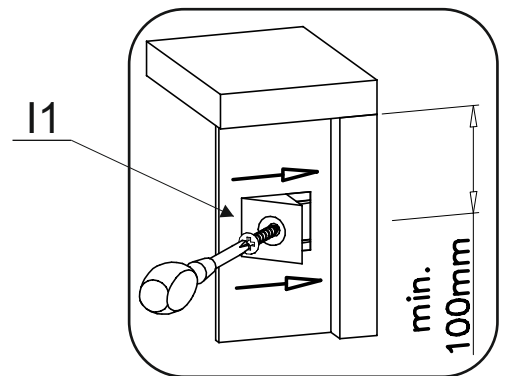
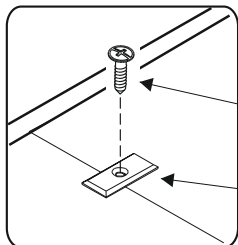
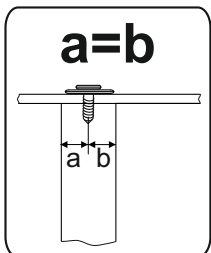

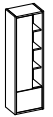

X

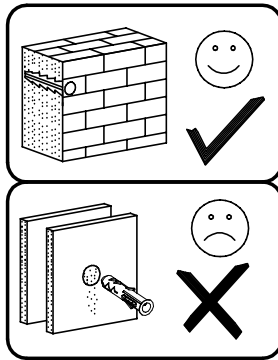
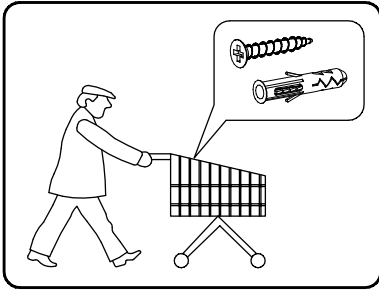

P14

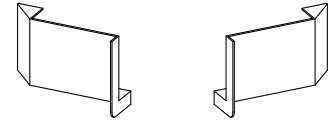

x1

P15

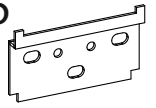

x2

I8



x14

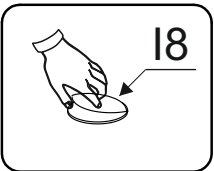
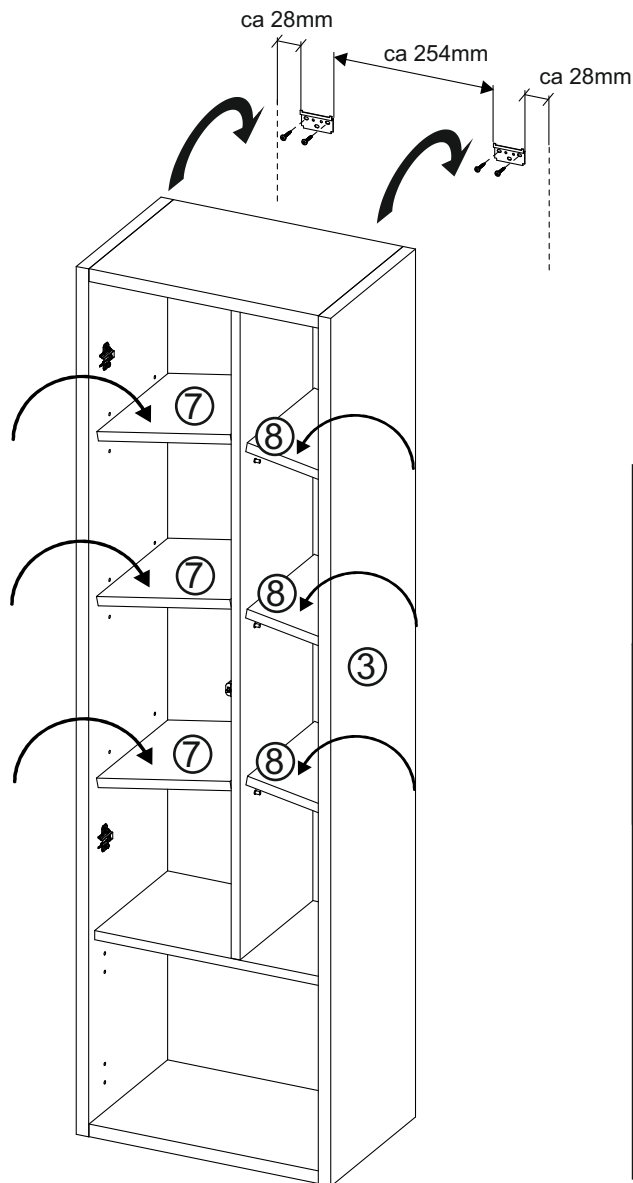
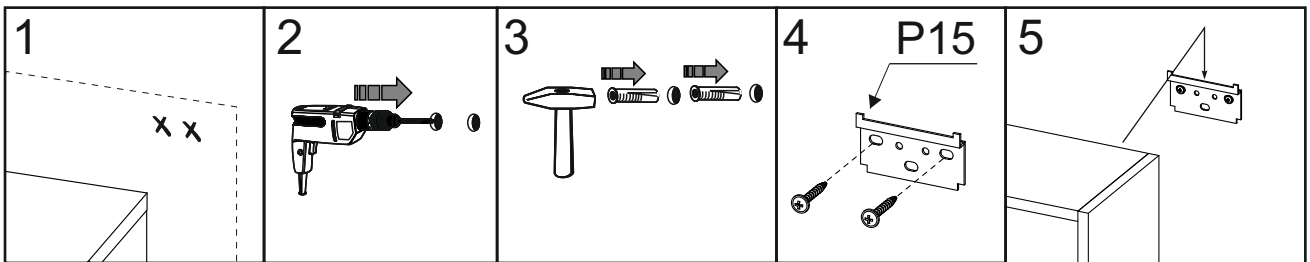

18

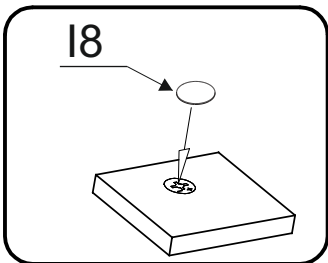

18

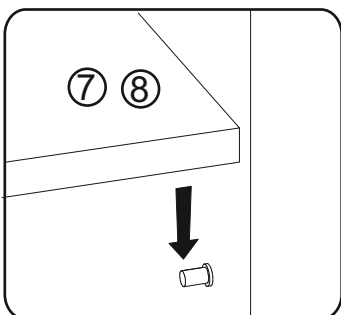

7 8

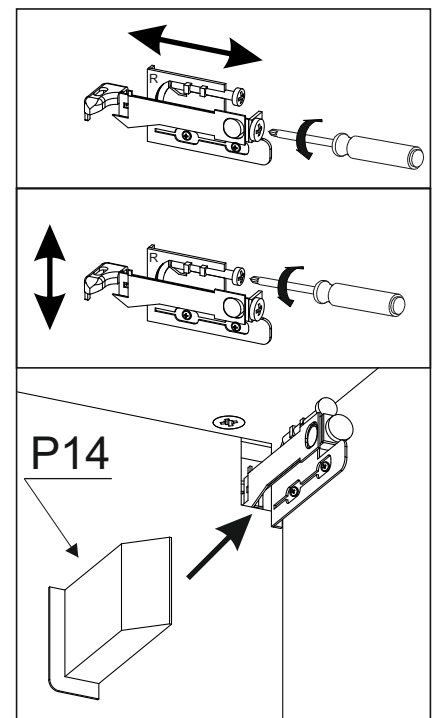

P14

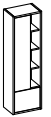

XI

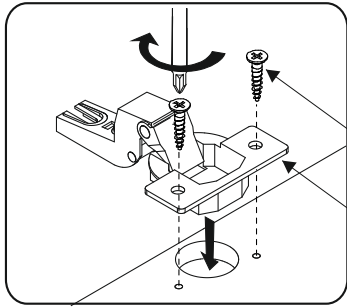

G34

C6

C6

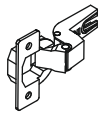

x4

G34



3,5x16

x8

C6

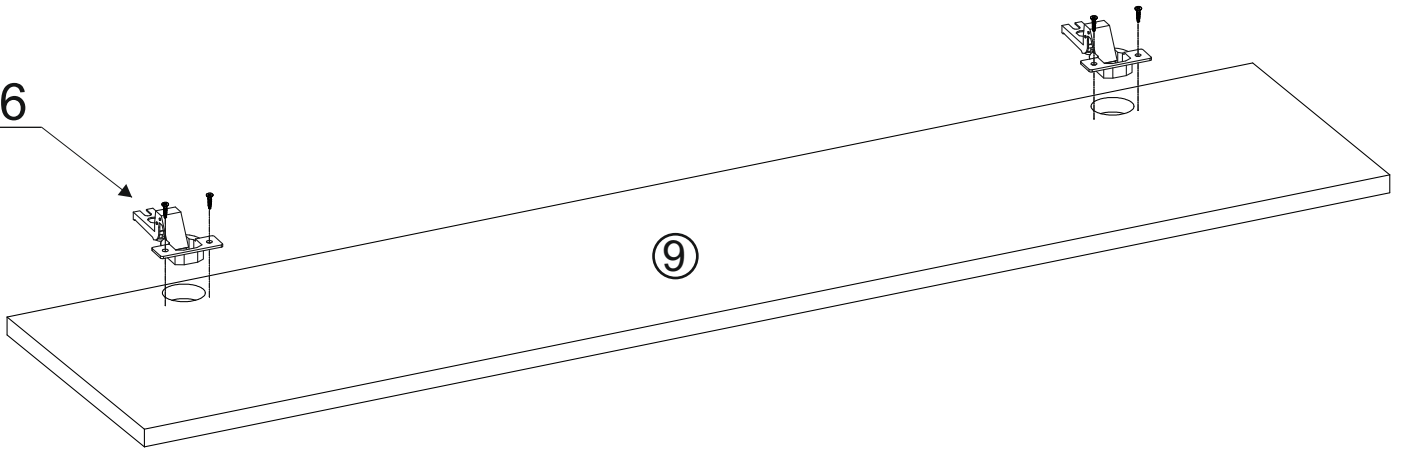

C6

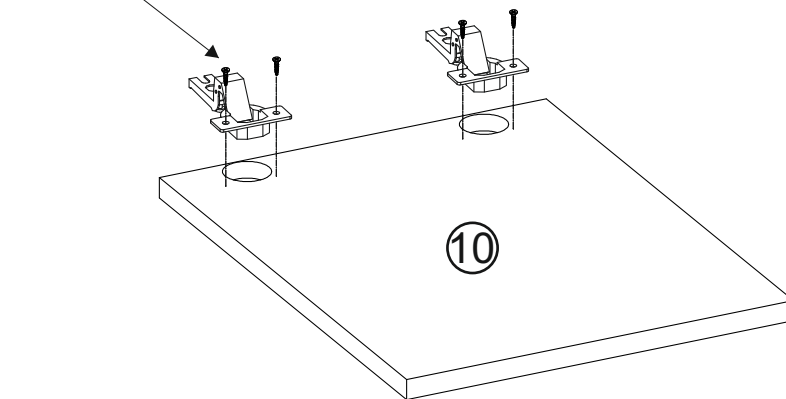

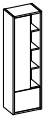

XII

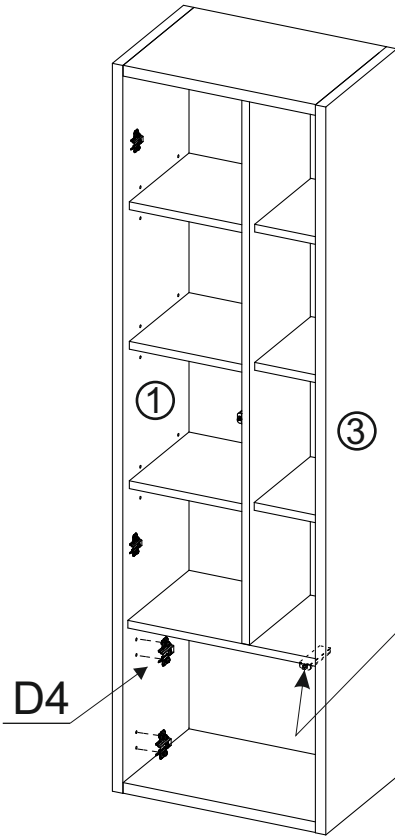
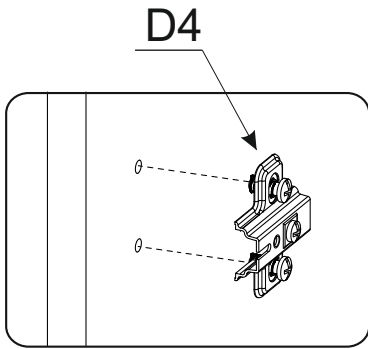
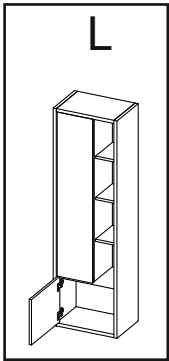

F10



x1

G34



3,5x16

x2

D4

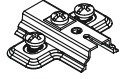

x2

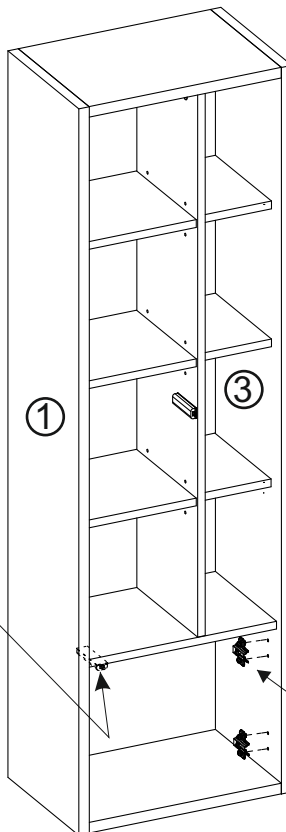
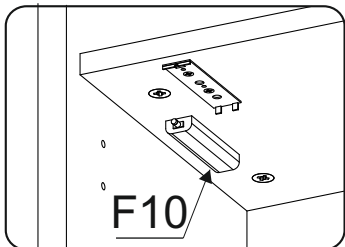
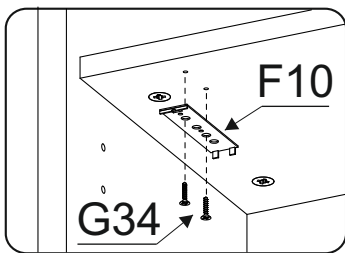
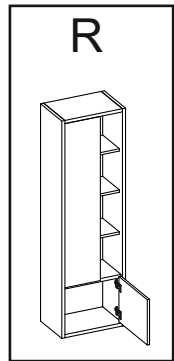
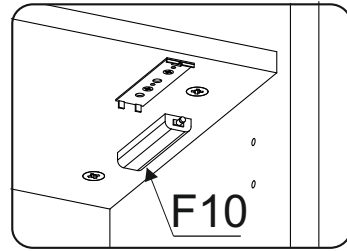
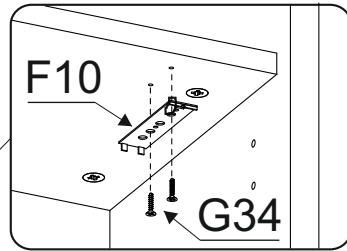

F10



x1

G34



3,5x16

x2

D4

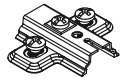

x2

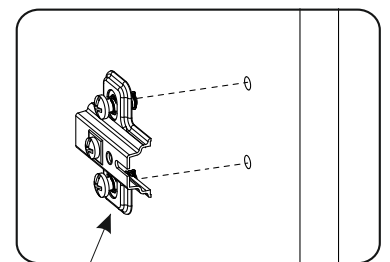

D4

D4

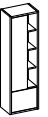

XIII

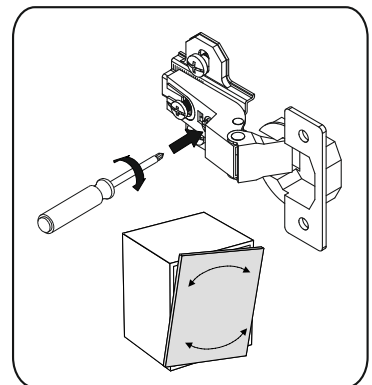
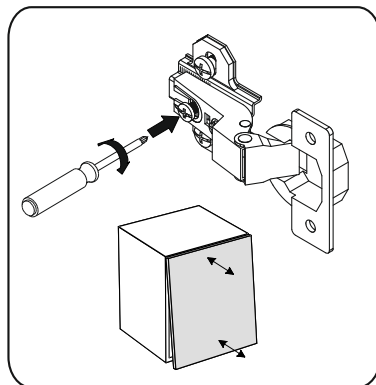
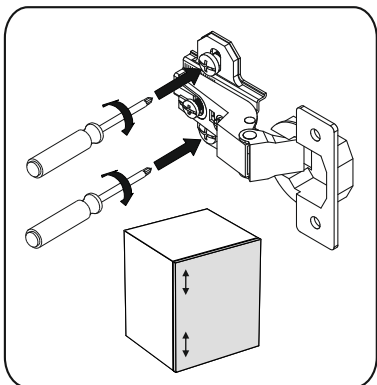
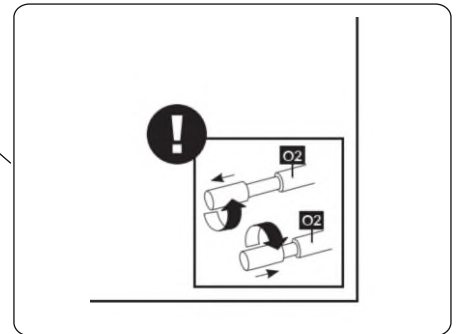
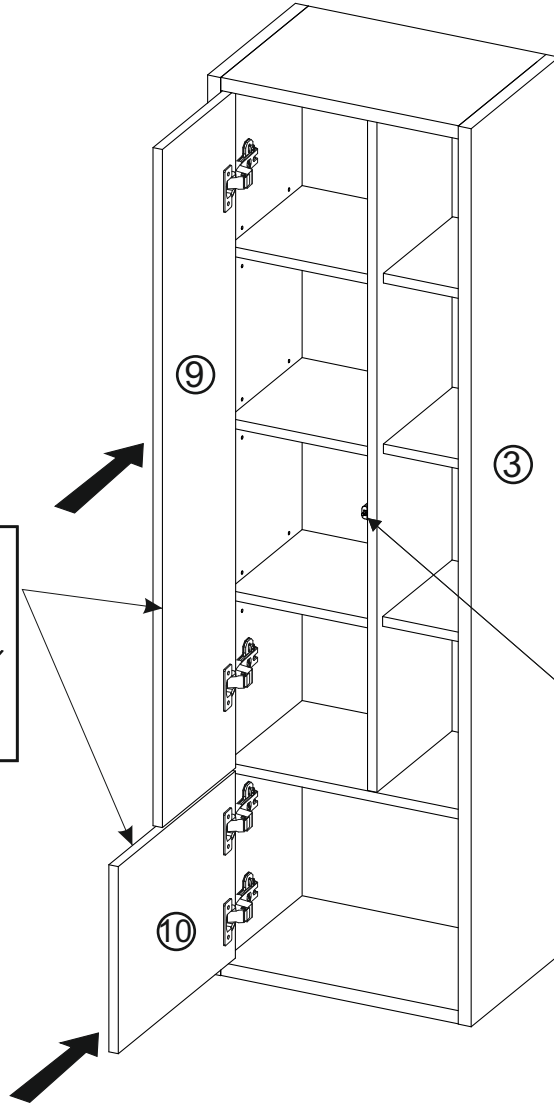
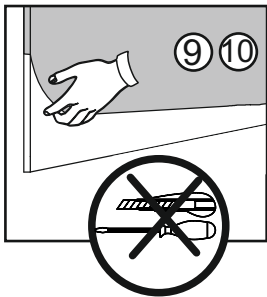
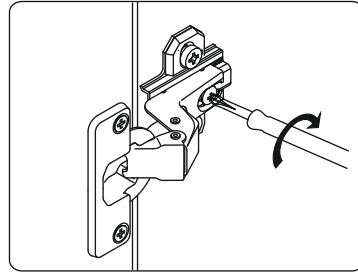
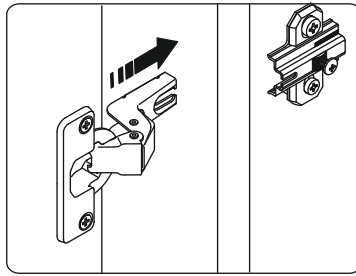
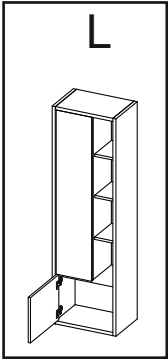

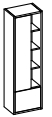

XIV

R

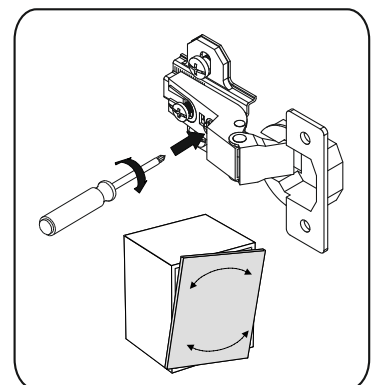
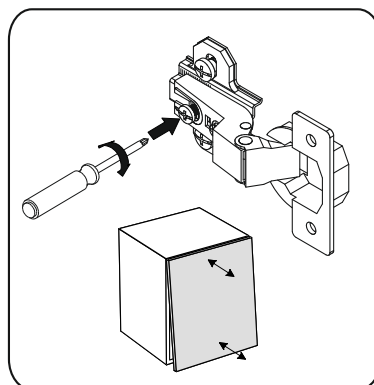
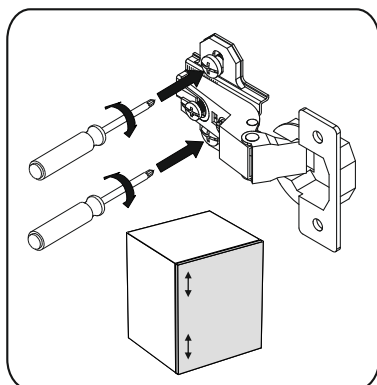
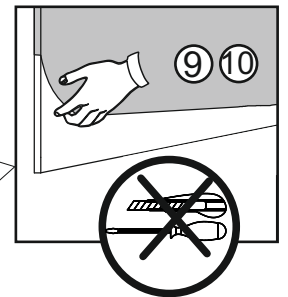
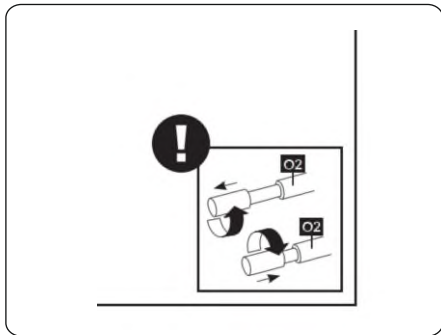
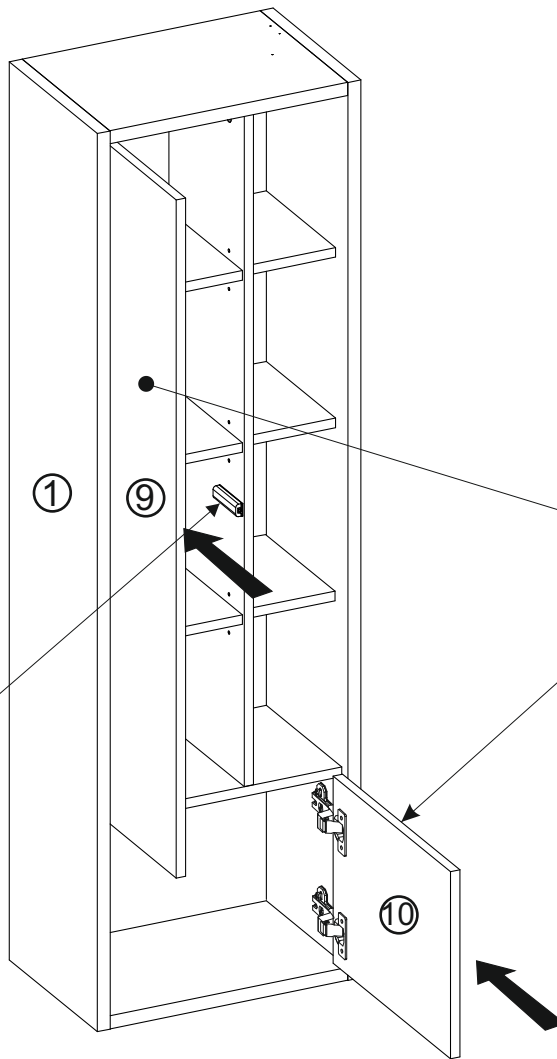
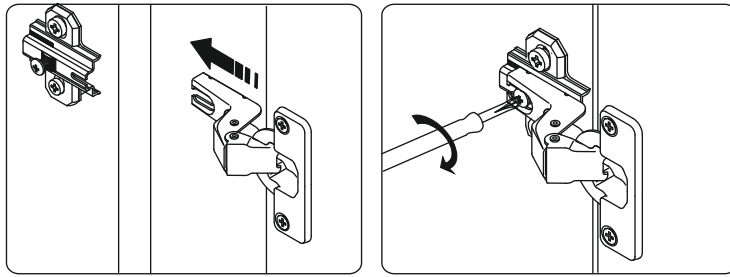
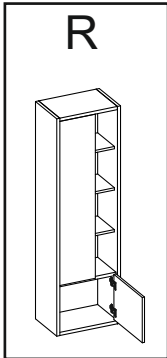

Name • Nom • Nome • Naam • Nazwa • Imięno • Názov • Név • Denumire • Isim • Имянаие

Nr • No • N° • Номер • Č • Sz

Typ • Type • Tip • Típus • Tipo • Tun

STUDIO LINE

— —

23

Unser Direktservice für Beschlagteile

Sollte Ihnen ein Beschlagteil fehlen, können Sie diese Servicekarte direkt an die untenstehende Adresse mailen. Wir können allerdings nur Beschlagteile auf diesem Wege verschicken. Sollten Sie eine andere Beanstandung an Ihrem Möbelstück haben, so wenden sie sich bitte direkt an Ihr Möbelhaus.

Our direct order service for fitting

If a fitting part is missing, you can e-mail this service card directly to the address below. However, we can only send fitting parts in this way. If you have any other cause for complaint concerning your item of furniture, please contact your furniture store directly.

Naše přímé služby pro kování

Chybí-li vám nějaký díl z kování, můžete tuto servisní kartu odeslat e-mailem přímo na níže uvedenou adresu. Touto cestou však můžeme zoslat jen díly kování. Pokud byste reklamovali jiný díl nábytku, obraťte se přímo na svého prodejce nábytku.

Bien etudier la notice de montage

S'il vous manque une ferrure, veuillez envoyer directement la présente carte service à l'adresse e-mail indiquée ci-dessous. Cependant, ceci nous permet uniquement d'envoyer des ferrures. Pour tout autre type de réclamation concernant votre meuble, veuillez contacter directement votre magasin d'ameublement.

Il nostro servizio diretto per l'ordine della ferramenta

Qualora Vi dovesse mancare un pezzo di fissaggio, allora Vi preghiamo di inviare questa carta di servizio immediatamente all'indirizzo sottostante. Possiamo inviare i pezzi di fissaggio solamente per mezzo di questo procedimento. Qualora dovete avere qualche altra reclamazione in merito al mobile, allora Vi preghiamo di rivolgerVi direttamente al Vostro Negozio di mobili.

Нашата директна услуга за обков

Ако липсват части от комплекта, попълнете настоящата сервисна карта и ни я изпратете на е-мил адреса, посочен по-долу. По този начин можем да доставяме само липсващи елементи от обкова. Ако установите други дефекти по мебелите, Ви съветваме да се обърнете към мебелната къща/магазин, от който сте закупили стоката.

Kunde directservice voor losse onderdelen

Wanneer er een onderdeel ontbreekt, kunt u deze servicekaart direct aan onderstaand e-mailadres sturen. Wij kunnen langs deze weg echter alleen beslagdelen versturen. Mocht u een ander probleem aan uw meubel hebben, verzoeken wij u contact op te nemen met uw meubeldealer.

Nasz bezpośredni serwis części montażowych

Jeżeli brakuje części koniecznych do montażu, prosimy o przesłanie nam niniejszej karty serwisowej na niżej podany adres e-mailowy. W ten sposób możemy przesłać Państwu tylko brakujące części. W przypadku innych reklamacji dotyczących mebla, prosimy zgłosić się do salonu meblowego, w którym został dokonany zakup.

Servis za okove

U slučaju da nedostaje neki od dijelova molimo vas da na dolje navedenu mail adresu pošaljete ovaj servisni obrazac. Na ovaj način mogu se dostaviti samo okovi. U slučaju da imate dodatne prigovore vezane uz komad namještaja molimo vas da se obratite izravno trgovini namještaja gdje je isti kupljen.

Direktszolgáltatunk vasalatok esetén

Ha hiányzik egy vasalat, ezt a kártyát közvetlenül elküldheti az alább található címre. Azonban csakis vasalatokat tudunk így küldeni. Amennyiben másfajta reklamáció áll fenn bűtorárábját illetően, forduljon közvetlenül a bűtorárázhoz.

Náš priamy servis pre části kovania

Ak by Vám chýbala nejaká časť kovania, môžete poslať túto servisnú kartu poslať e-mailom na nižšie uvedení adresu. Diely kovania vieme poslať iba týmto spôsobom. Ak by ste mali inú reklamáciu ohľadom Vášho nábytku, obráťte sa priamo na Vašu predajňu nábytku.

Naše direktno uslužne storitve za okovje

Če vam manjka kakšno okovje, lahko to servisno kartico pošljete po e-pošti direktno na spodnji naslov. Po tej poti vam lahko pošljemo samo okovje. Če želite reklamirati kakšen drug del pohištva, se obrnite neposredno na vašo trgovino pohištva.

Service-ul nostru direct pentru feronerie

În cazul în care vă lipsește o piesă de feronerie puteți să trimiteți direct acest card de service prin e-mail la adresa de mai jos. Noi nu putem expedia piese de feronerie decât pe această cale. Dacă aveți o altă reclamație referitoare la piesa de mobilier, atunci vă rugăm să vă adresați direct la magazinul dvs. de mobilă.

Наш прямой сервис для поставок фурнитуры

Если окажется, что Вам не хватает того или иного элемента фурнитуры, Вы можете отправить сервисную карту по факсу непосредственно на нижеприведенный адрес электронной почты. Однако, таким образом мы можем пересылать лишь фурнитуру. Если же у Вас возникнут иные претензии относительно приобретенной мебели, пожалуйста, обращайтесь непосредственно в организацию, осуществившую продажу.

Vår direktservice för beslagsdelar

Om du saknar en beslagsdel kan du skicka detta servicekort direkt till e-postadressen som anges nedan. Tank på att detta är den enda möjligheten att skicka beslagsdelar till dig. Om du vill reklamera din möbel av en annan anledning måste du kontakta ditt möbelhus direkt.

Nuestro servicio directo para accesorios

Si le falta algún accesorio, puede enviar esta tarjeta de servicio directamente a la siguiente dirección. No obstante, por este método solo podemos enviar accesorios. Si tiene alguna otra objeción sobre su mueble, consulte directamente con su mueblería.

Donatilar için doğrudan servisimiz

Bir donatınız eksikse bu servis kartını doğrudan aşağıda bulunan adrese doğrudan mail yazabilirsiniz. Sadece bu yolla donatılar gönderiliriz. Mobilyanızda başka şikayetleriniz varsa lütfen doğrudan mobilya satıcınıza danışın.

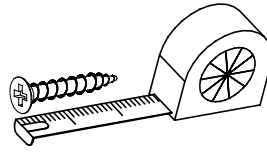

B1 ø8x35 x...	I8 x...	K1 x...
K10 x...	D4 x...	C6 x...
G34 3,5x16 x...	F2 x...	I1 x...
P15 x...	P12 L R x...	
P14 x...	G51 x...	
F10 x...	A1 ø7x50 x...	
W2 x...	G50 3x20 x...	Z6 x...

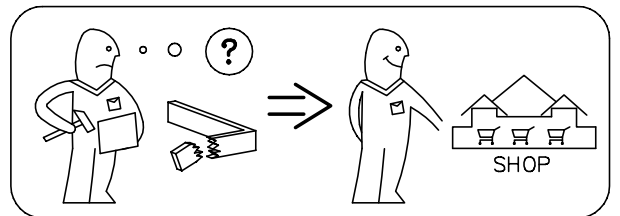
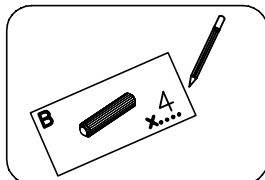

Name • Nom • Nome • Naam • Nazwa • Имяно
• Názov • Név • Denumire • Im • Имя

Nr • No • N° • Номер • Č • Sz

Typ • Type • Tip • Típus • Tipo • Tun

STUDIO LINE

— —

23

Unsere Direktservice für Beschlagteile

Sollte Ihnen ein Beschlagteil fehlen, können Sie diese Servicekarte direkt an die untenstehende Adresse mailen. Wir können allerdings nur Beschlagteile auf diesem Wege verschicken. Sollten Sie eine andere Beanstandung an Ihrem Möbelstück haben, so wenden Sie sich bitte direkt an Ihr Möbelhaus.

Our direct order service for fitting

If a fitting part is missing, you can e-mail this service card directly to the address below. However, we can only send fitting parts in this way. If you have any other cause for complaint concerning your item of furniture, please contact your furniture store directly.

Naše přímé služby pro kování

Chybí-li vám nějaký díl z kování, můžete tuto servisní kartu odeslat e-mailem přímo na níže uvedenou adresu. Touto cestou však můžeme zoslat jen díly kování. Pokud byste reklamovali jiný díl nábytku, obraťte se přímo na svého prodejce nábytku.

Bien etudier la notice de montage

S'il vous manque une ferrure, veuillez envoyer directement la présente carte service à l'adresse e-mail indiquée ci-dessous. Cependant, ceci nous permet uniquement d'envoyer des ferrures. Pour tout autre type de réclamation concernant votre meuble, veuillez contacter directement votre magasin d'ameublement.

Il nostro servizio diretto per l'ordine della ferramenta

Qualora Vi dovesse mancare un pezzo di fissaggio, allora Vi preghiamo di inviare questa carta di servizio immediatamente all'indirizzo sottostante. Possiamo inviare i pezzi di fissaggio solamente per mezzo di questo procedimento. Qualora dovete avere qualche altra reclamazione in merito al mobile, allora Vi preghiamo di rivolgerVi direttamente al Vostro Negoziario di mobili.

Нашата директна услуга за обков

Ако липсват части от комплекта, попълнете настоящата сервисна карта и ни я изпратете на e-mail адреса, посочен по-долу. По този начин можем да доставяме само липсващи елементи от обкова. Ако установите други дефекти по мебелите, Ви съветваме да се обърнете към мебелната къща/магазин, от който сте закупили стоката.

Onze directservice voor losse onderdelen

Wanneer er een onderdeel ontbreekt, kunt u deze servicekaart direct aan onderstaand e-mailadres sturen. Wij kunnen langs deze weg echter alleen beslagdelen versturen. Mocht u een ander probleem aan uw meubel hebben, verzoeken wij u contact op te nemen met uw meubeldealer.

Nasz bezpośredni serwis części montażowych

Jeżeli brakuje części koniecznych do montażu, prosimy o przesłanie nam niniejszej karty serwisowej na niżej podany adres e-mailowy. W ten sposób możemy przelać Państwu tylko brakujące części. W przypadku innych reklamacji dotyczących mebla, prosimy zgłosić się do salonu meblowego, w którym został dokonany zakup.

Servis za okove

U slučaju da nedostaje neki od dijelova molimo vas da na dolje navedenu mail adresu pošaljete ovaj servisni obrazac. Na ovaj način mogu se dostaviti samo okovi. U slučaju da imate dodatne prigovore vezane uz komad namještaja molimo vas da se obratite izravno trgovini namještaja gdje je isti kupljen.

Direktszolgáltatunk vasalatók esetén

Ha hiányzik egy vasalat, ezt a kártyát közvetlenül elküldheti az alább található címre. Azonban csakias vasalatókat tudunk így küldeni. Amennyiben másfajta reklámáció áll fenn bútordarabjárt illetően, forduljon közvetlenül a bútorházhoz.

Náš priamy servis pre časti kovania

Ak by Vám chýbala nejaká časť kovania, môžete poslať túto servisnú kartu poslať e-mailom na nižšie uvedenú adresu. Diely kovania vieme poslať iba týmto spôsobom. Ak by ste mali inú reklamáciu ohľadom Vášho nábytku, obráťte sa priamo na Vašu predajňu nábytku.

Naše direktno uslužne storitve za okovje

Če vam manjka kakšno okovje, lahko to servisno kartico pošljete po e-pošti direktno na spodnji naslov. Po tej poti vam lahko pošljemo samo okovje. Če želite reklamirati kakšen drug del pohištva, se obrnite neposredno na vašo trgovino pohištva.

Service-ul nostru direct pentru feronerie

În cazul în care vă lipsește o piesă de feronerie puteți să trimiteți direct acest card de service prin e-mail la adresa de mai jos. Noi nu putem expedia piese de feronerie decât pe această cale. Dacă aveți o altă reclamație referitoare la piesa de mobilier, atunci vă rugăm să vă adresați direct la magazinul dvs. de mobilier.

Наш прямой сервис для поставок фурнитуры

Если окажется, что Вам не хватает того или иного элемента фурнитуры, Вы можете отправить сервисную карту по факсу непосредственно на нижеприведенный адрес электронной почты. Однако, таким образом мы можем пересылать лишь фурнитуру. Если же у Вас возникнут иные претензии относительно приобретенной мебели, пожалуйста, обращайтесь непосредственно в организацию, осуществившую продажу.

Vår direktservice för beslagsdelar

Om du saknar en beslagsdel kan du skicka detta servicekort direkt till e-postadressen som anges nedan. Tänk på att detta är den enda möjligheten att skicka beslagsdelar till dig. Om du vill reklamera din möbel av en annan anledning måste du kontakta ditt möbelhus direkt.

Nuestro servicio directo para accesorios

Si le falta algún accesorio, puede enviar esta tarjeta de servicio directamente a la siguiente dirección. No obstante, por este método solo podemos enviar accesorios. Si tiene alguna otra objeción sobre su mueble, consulte directamente con su mueblería.

Donatilar için doğrudan servisimiz

Bir donatınız eksikse bu servis kartını doğrudan aşağıda bulunan adrese doğrudan mail yazabilirsiniz. Sadece bu yolla donatılar gönderilebilir. Mobilyanızda başka şikayetleriniz varsa lütfen doğrudan mobilya satıcınıza danışın.

nr	L[mm]	B[mm]	T[mm]	Menge	Colli
1	1503	300	22	1	1/1
2	1134	257	16	1	1/1
3	1503	300	22	1	1/1
4	406	299	22	1	1/1
5	406	258	16	1	1/1
6	406	299	22	1	1/1
7	252	241	16	3	1/1

nr	L[mm]	B[mm]	T[mm]	Menge	Colli
8	237	149	16	3	1/1
9	1135	250	16	1	1/1
10	313	400	16	1	1/1
11	1146	253	3	1	1/1
12	1146	162	3	1	1/1
13	416	321	3	1	1/1

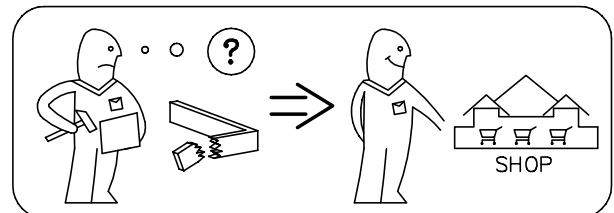
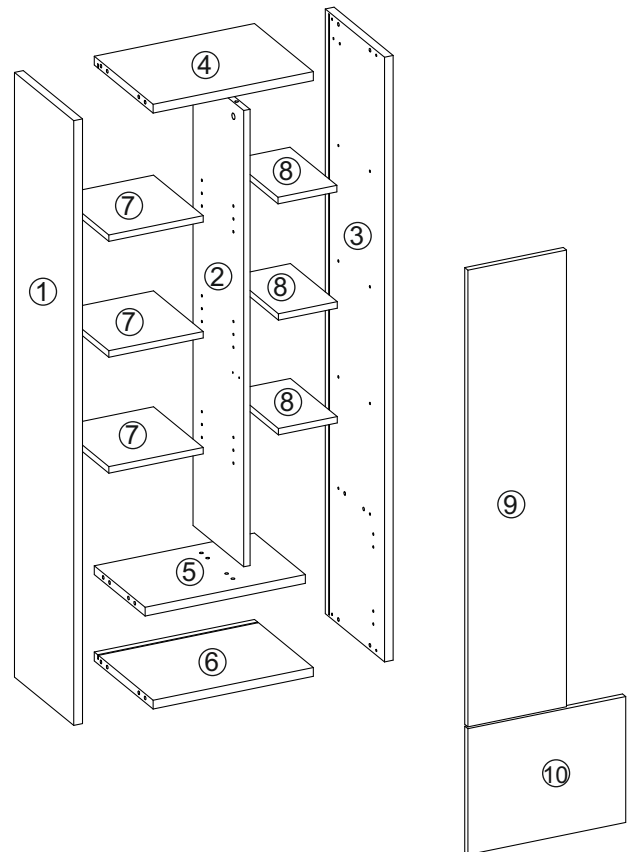
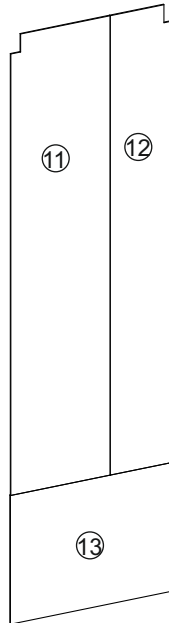

D GB CZ F I BG NL PL HR HU SK SLO RO RUS S ES TR

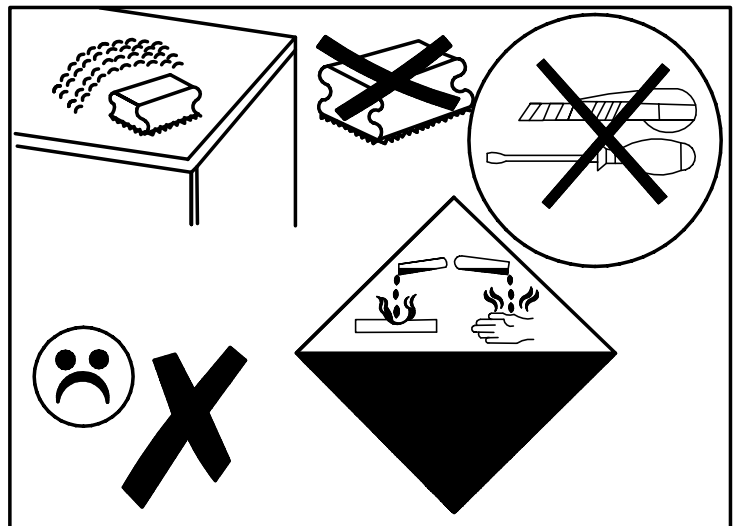
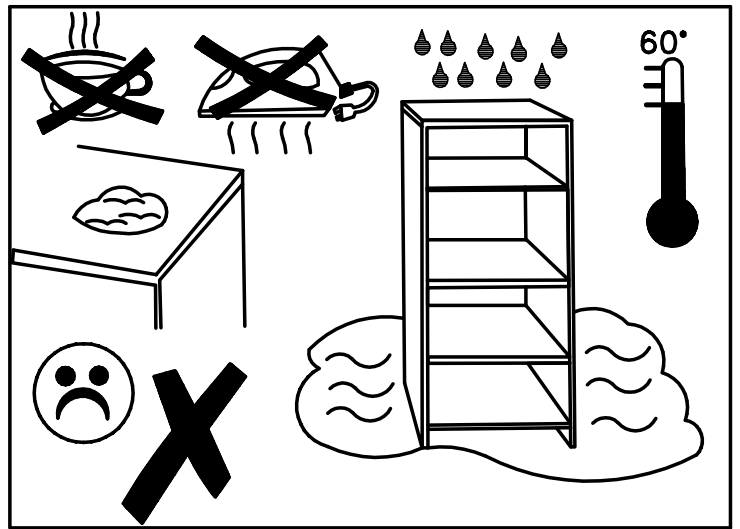
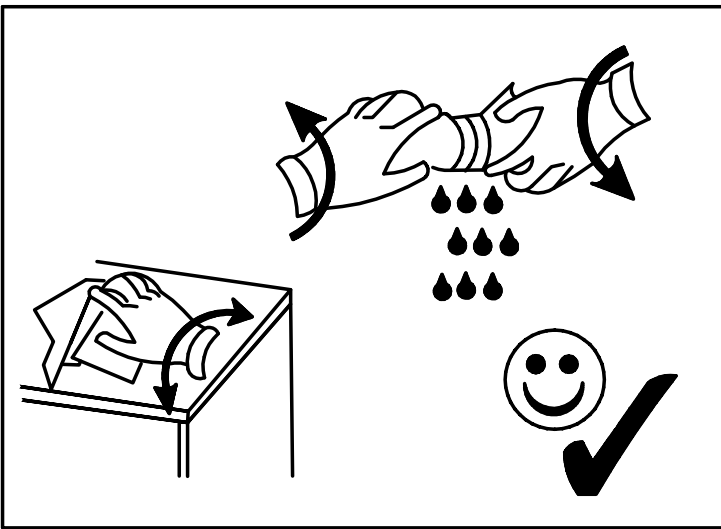
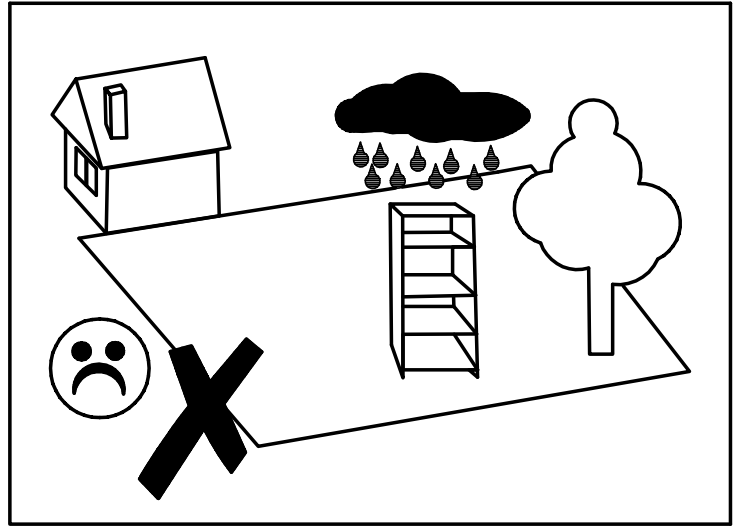
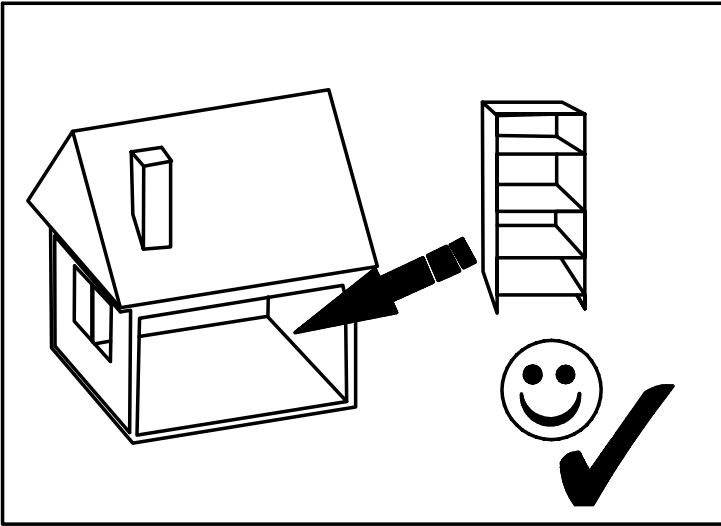

Modell: STUDIO LINE 65

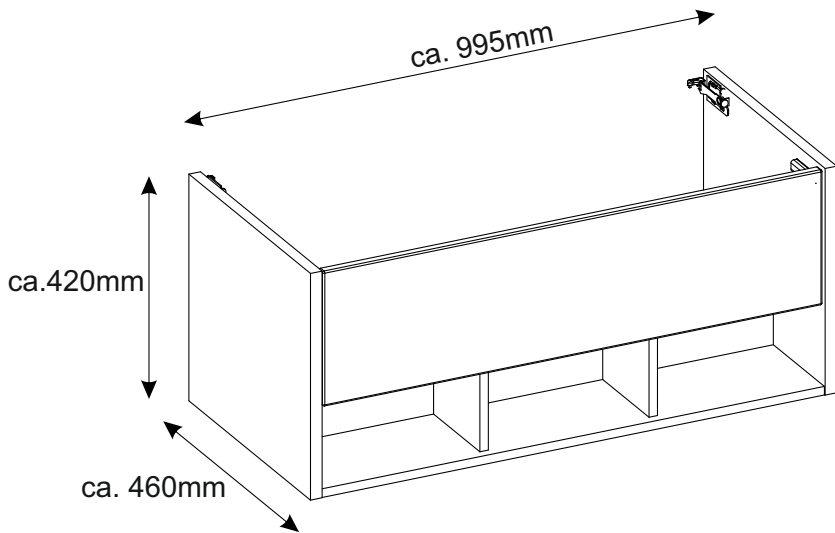

- Ⓛ Montageanleitung
- ⓃL Handleiding voor de montage
- ⓂR Montaj talimati
- Ⓛ Notice de montage
- ⓃZ Montážní návod
- ⓂU Szerelési útmutató
- ⓂB Assembly instructions
- ⓂL Instrukcja montażu
- ⓂU Инструкция по монтажу
- ⓂT Istruzioni di montaggio
- ⓂK Návod na montáž
- ⓂO Instrucțiuni de montaj
- ⓂS Instrucciones de montaje
- ⓂR Montaj Talimati

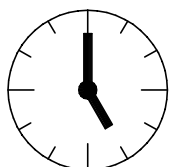
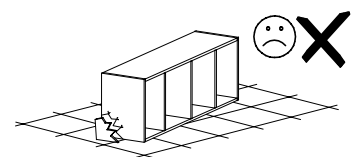
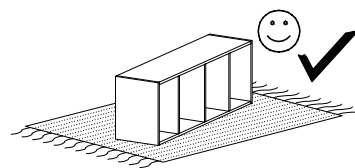
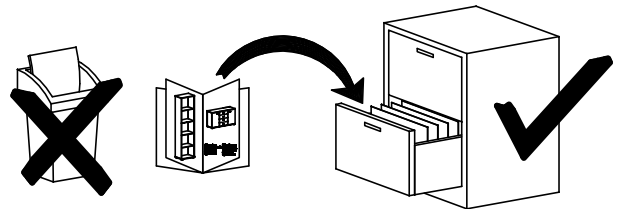
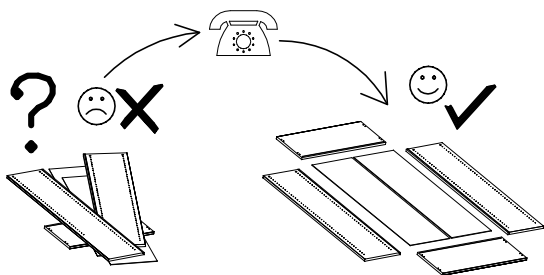
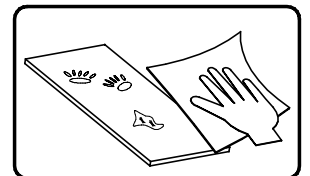
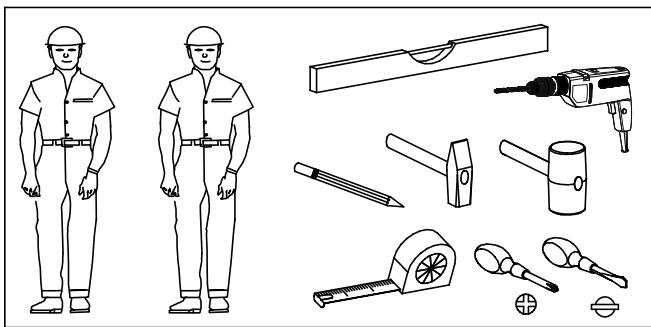

1,2h

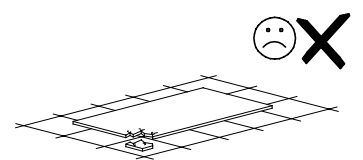
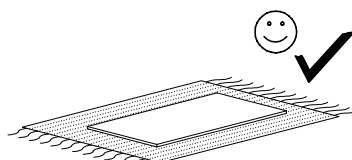

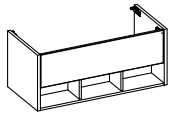



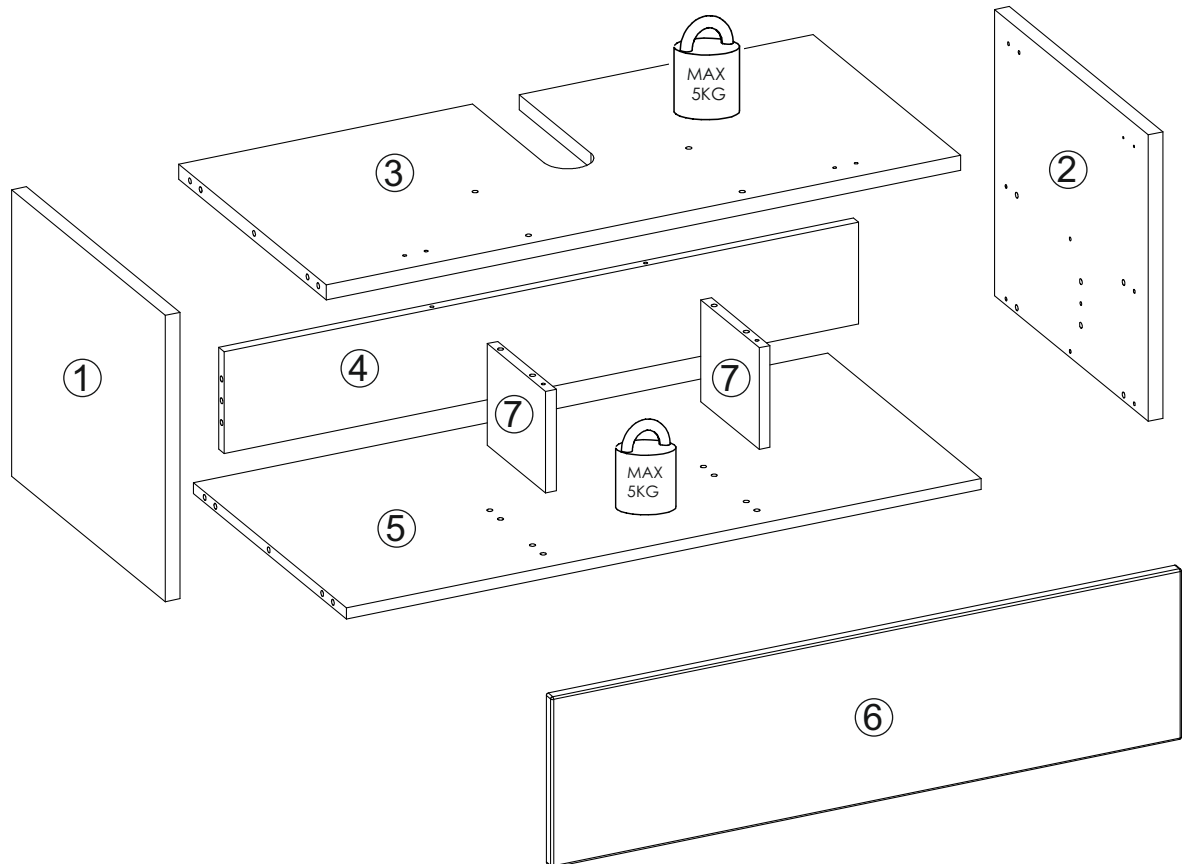

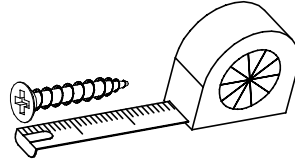
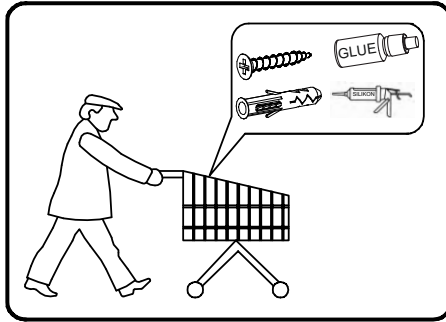
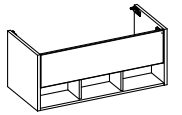

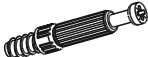
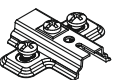
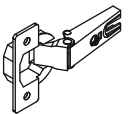

nr	L[mm]	B[mm]	T[mm]	Menge	Colli
1	420	460	22	1	1/1
2	420	460	22	1	1/1
3	950	442	16	1	1/1
4	950	149	16	1	1/1
5	950	459	16	1	1/1
6	944	250	16	1	1/1
7	149	175	16	2	1/1

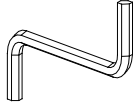
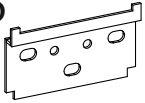
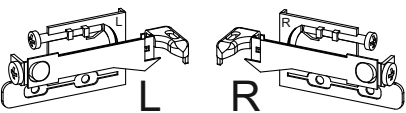
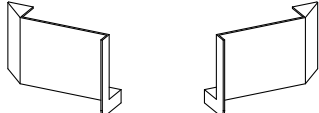

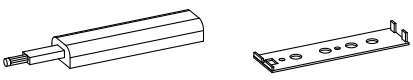
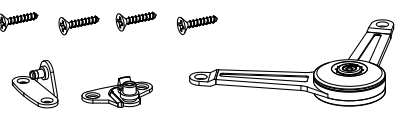

B1  ø8x35 x20	I8  x16	K1  x14	K10  x14	D4  x2
C7  x2	G34  3,5x16 x6	A1  ø7x50 x8	W2  x1	P15  x2
P12  L R x1		P14  x1		G51  x4
F10  x1		P15  x1		O3  x1

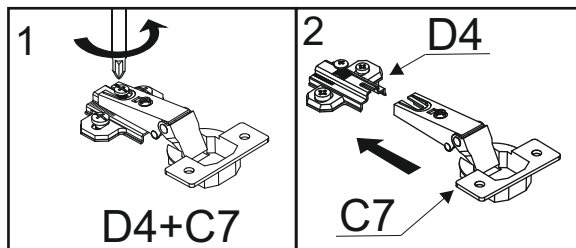

=

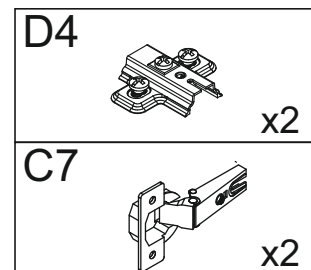

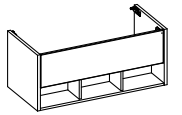

I

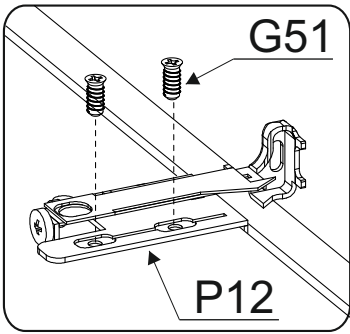

G34 3,5x16 x2	F10 x1
G51 x4	P12 L R x1

K10 x14
B1 ø8x35 x8

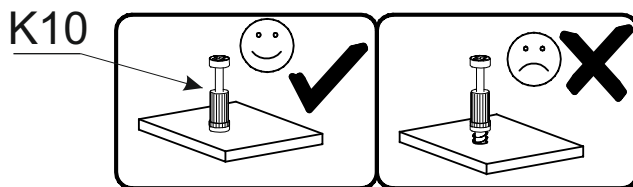
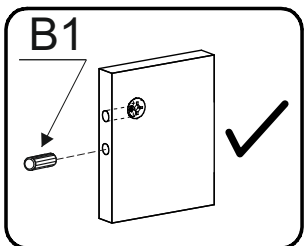
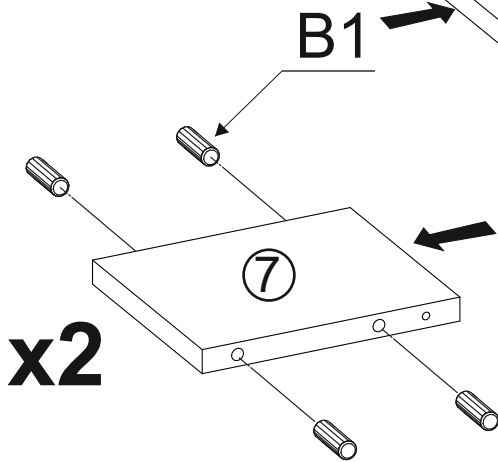
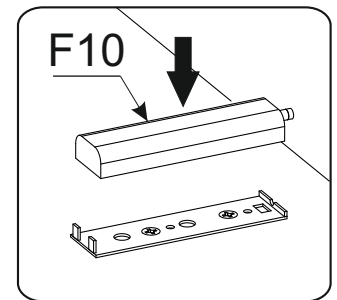
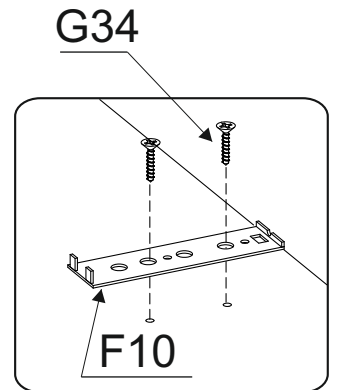
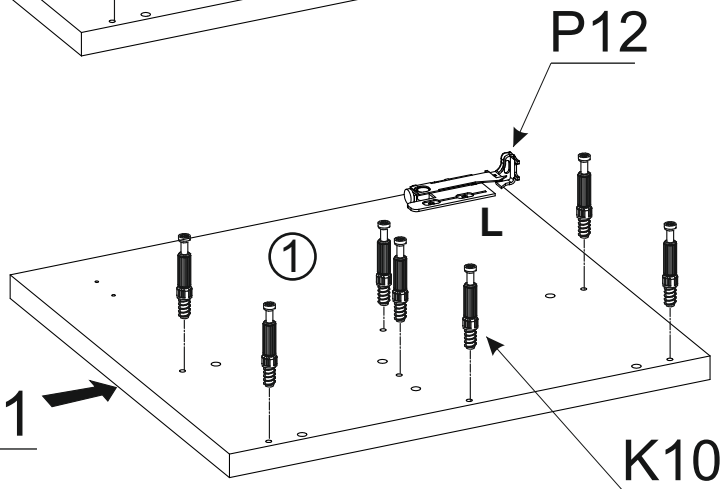
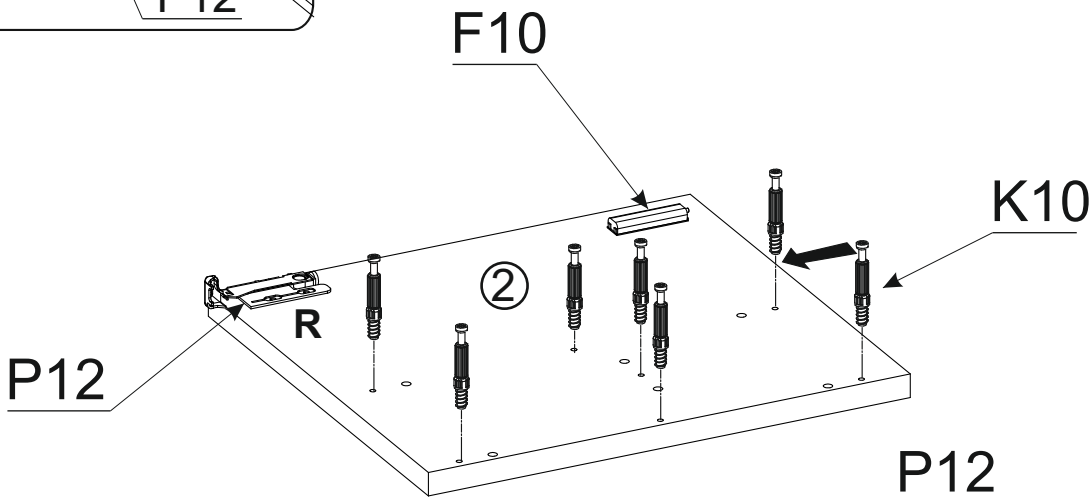

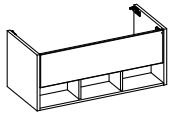

II

K1



x8

B1



ø8x35

x8

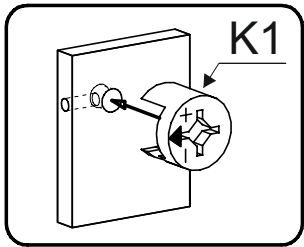
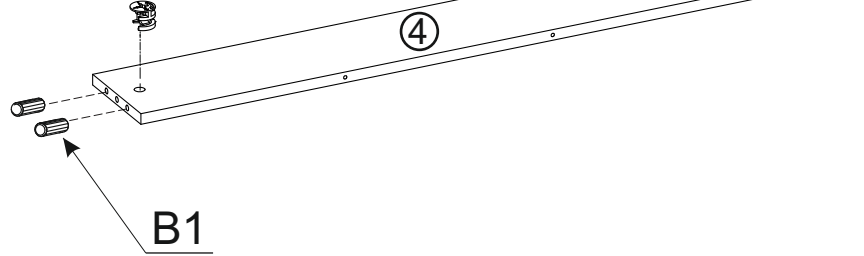
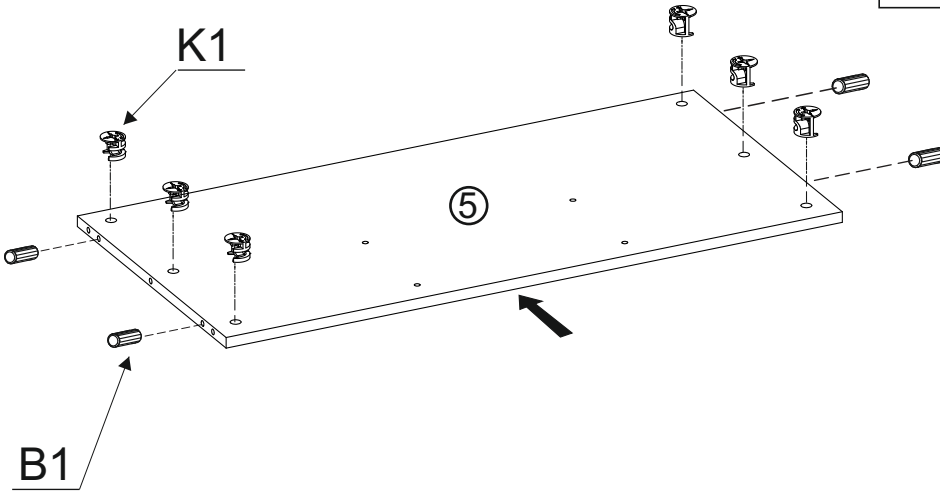

III

K1



x6

B1



ø8x35

x4

D4

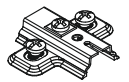

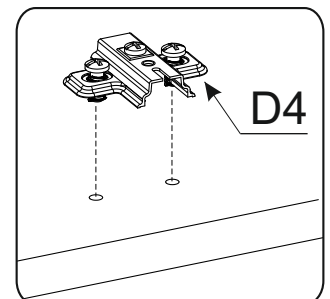
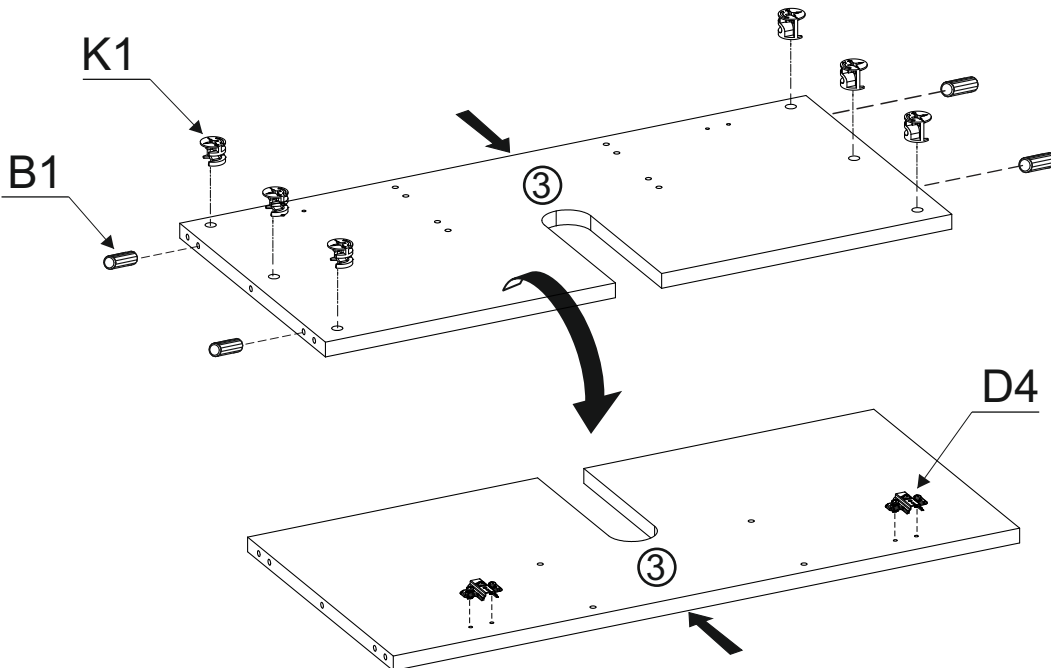

x2

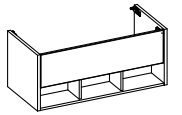

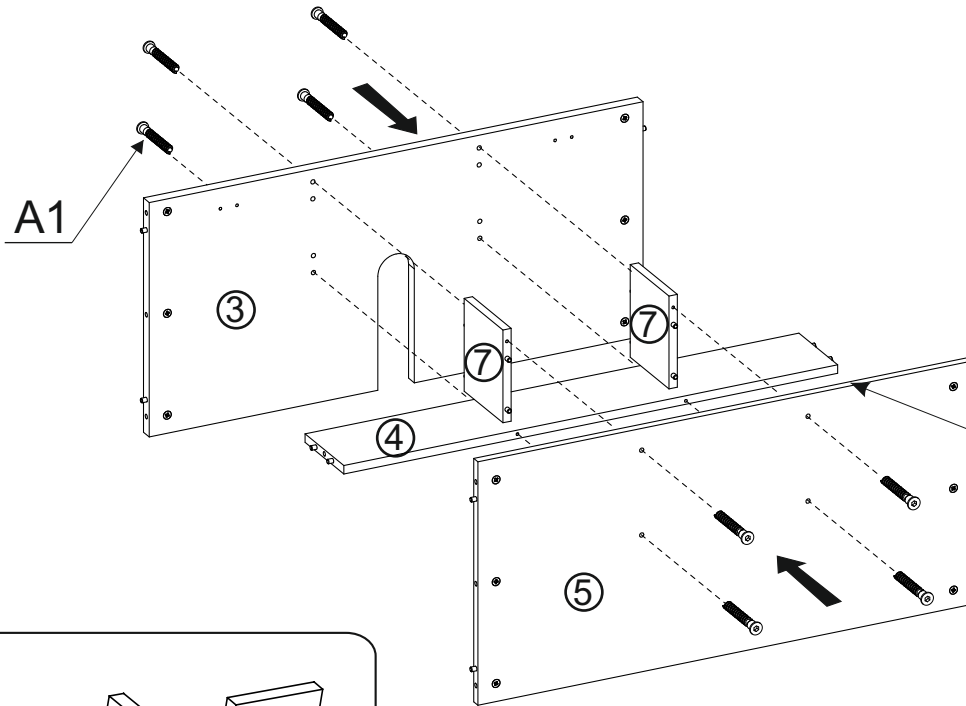

IV

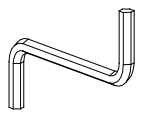

- A1  x8
- W2  x1

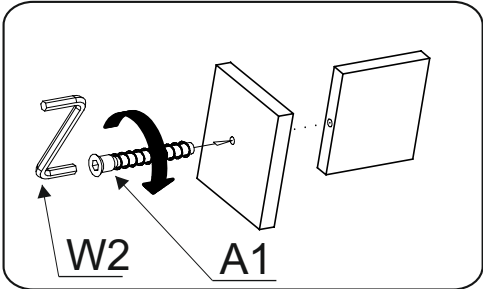

5

24 H

V

1 2

24 H

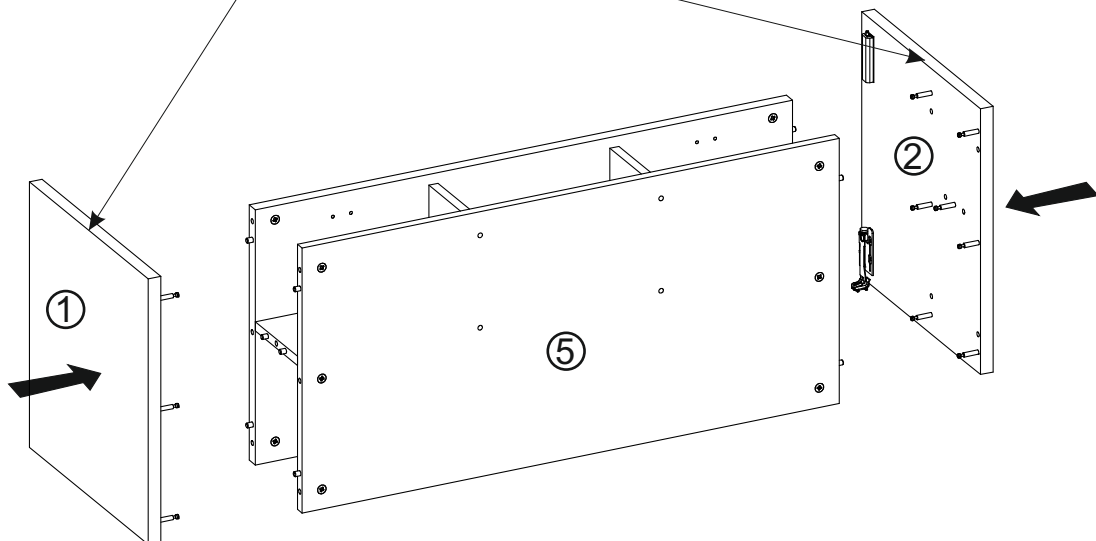
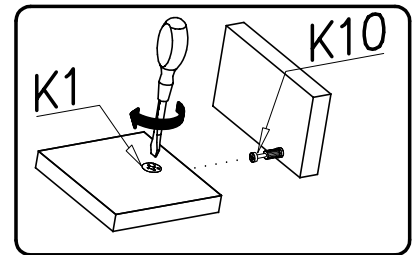

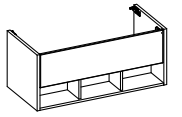

VI

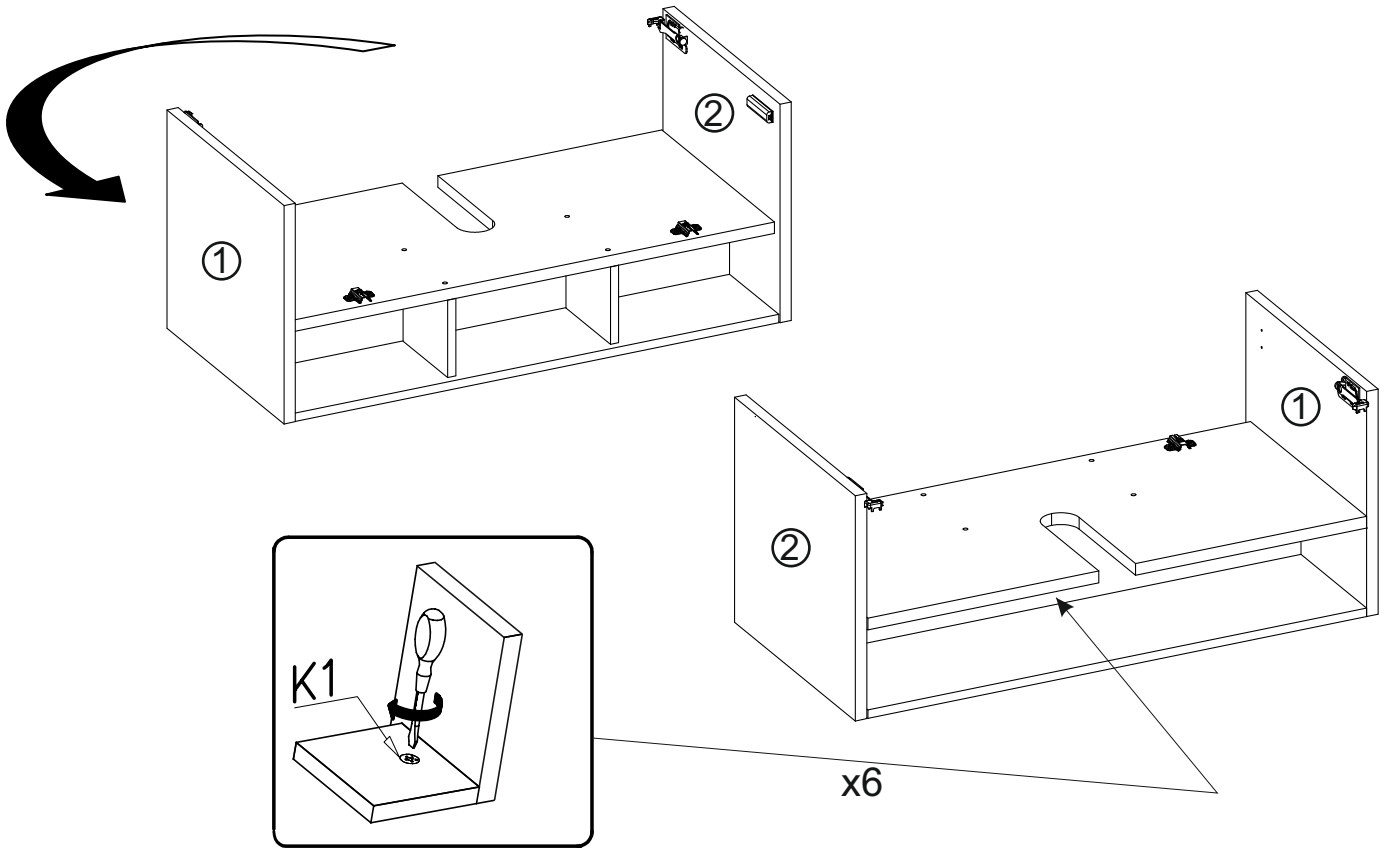

VII

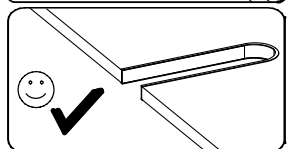
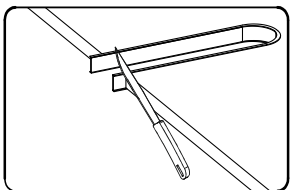
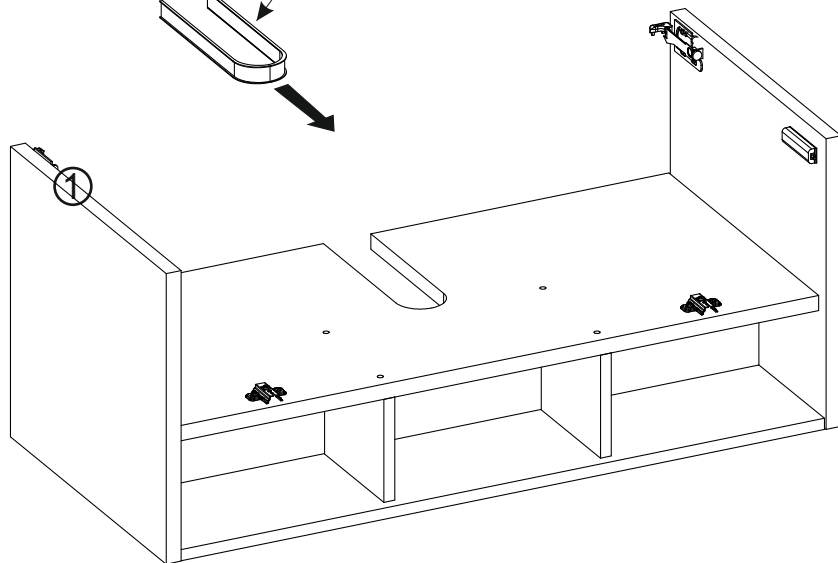
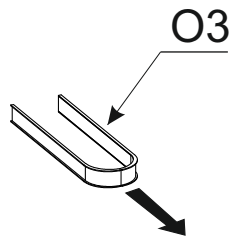
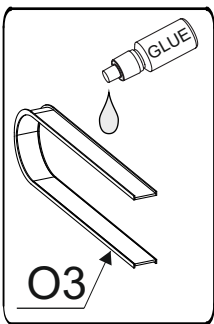
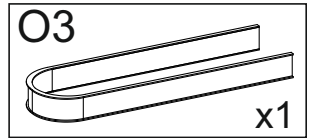
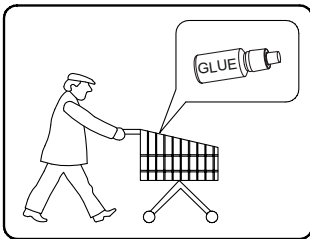

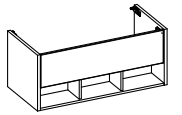

VIII

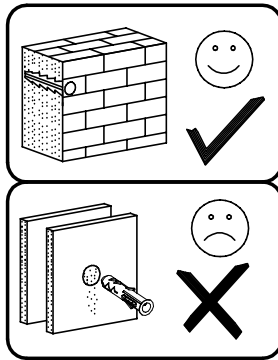
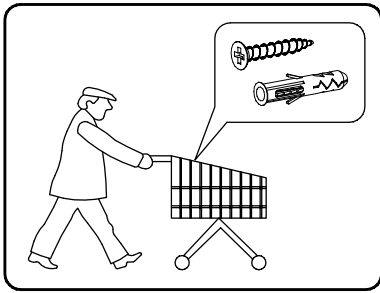

P14

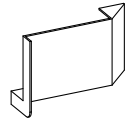
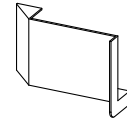

x1

P15

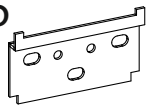

x2

I8



x16

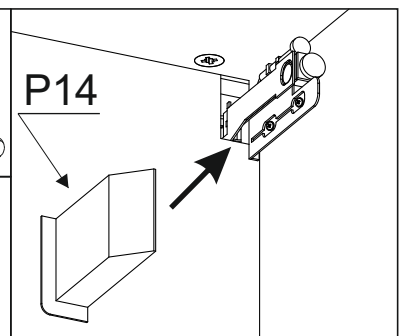
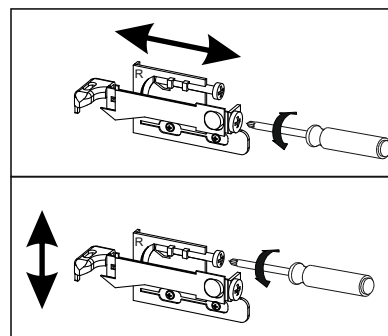
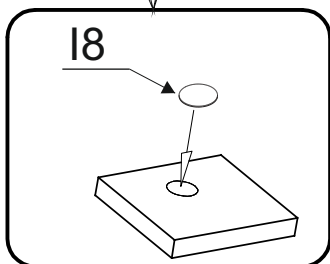
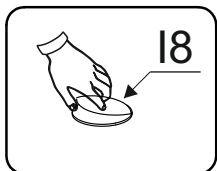
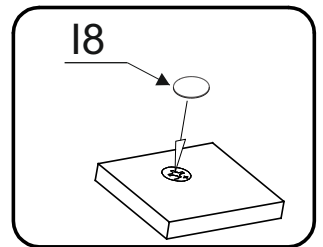
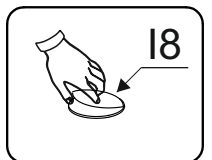
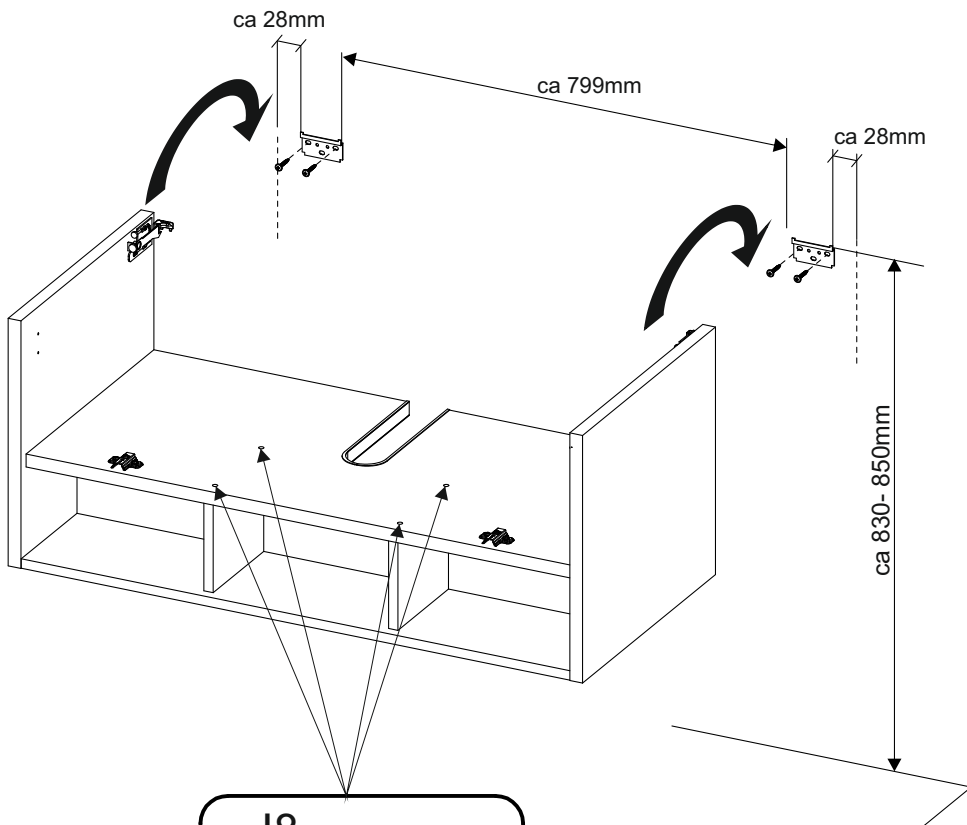
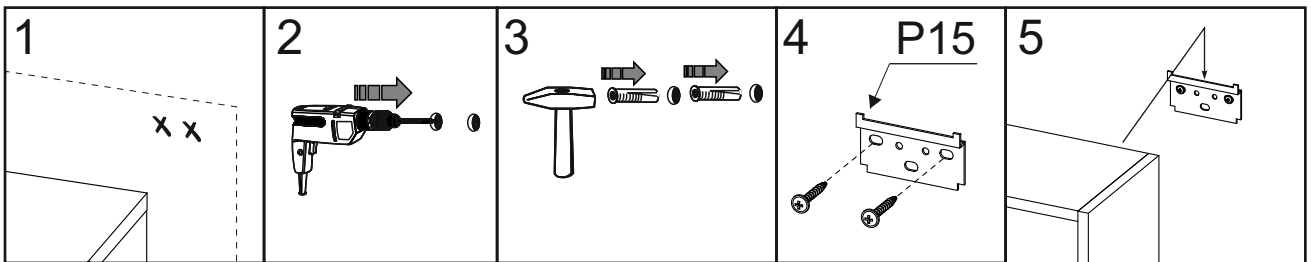

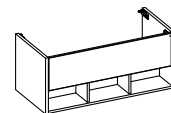

IX

P15

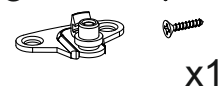

P15

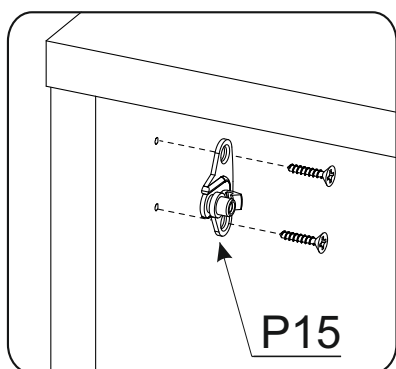
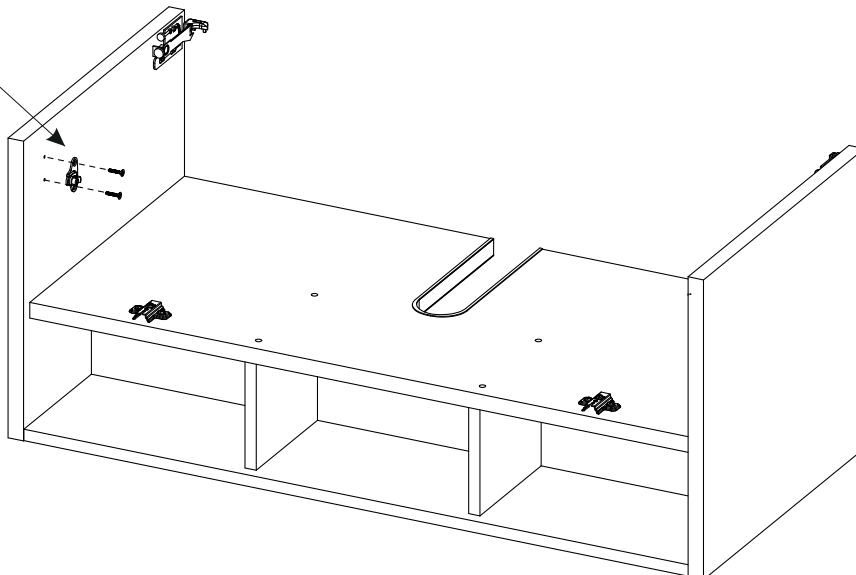

P15

X

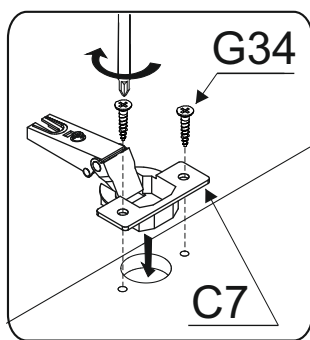

C7

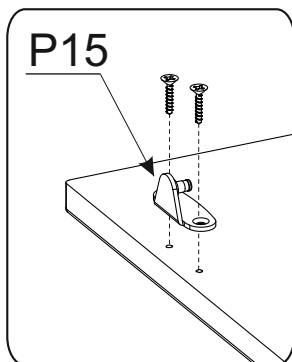

P15

C7

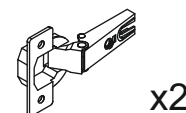

x2

G34



3,5x16

x4

P15



x1

C7

P15

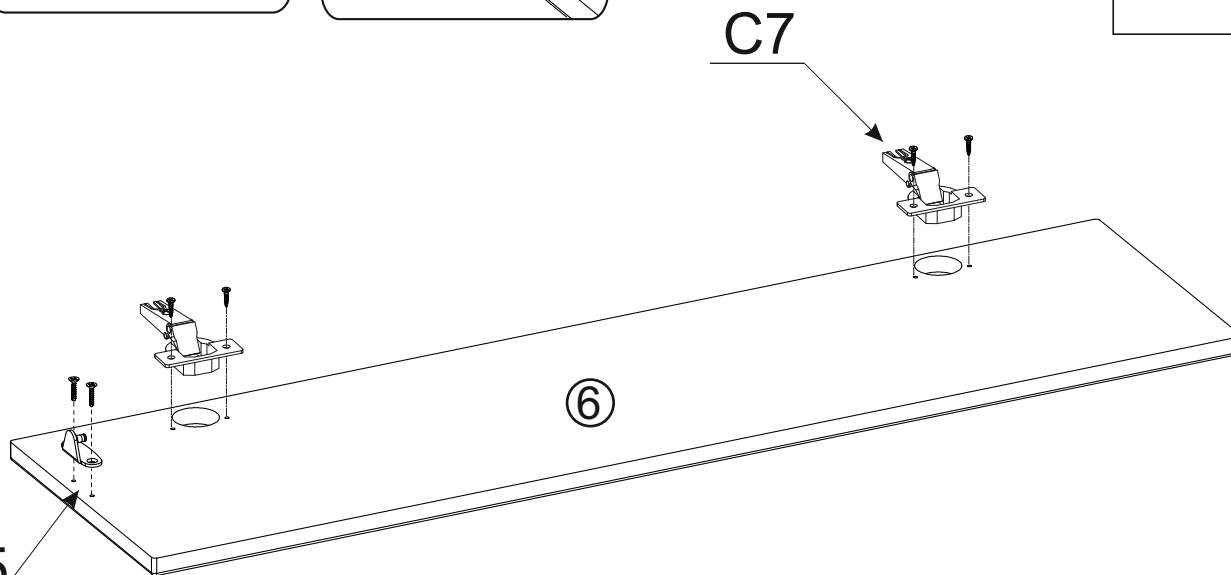

6

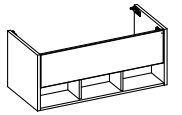

XI

1.

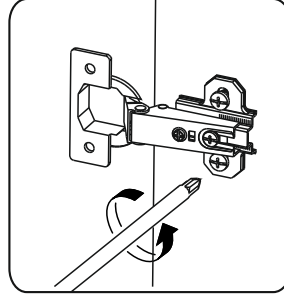
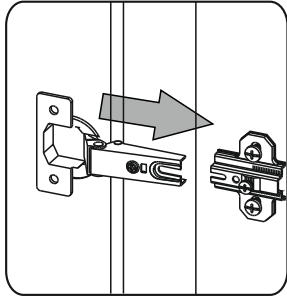

P15

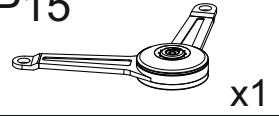

2.

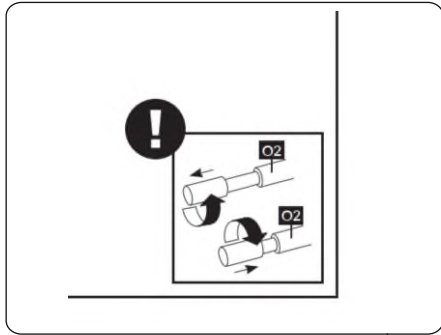

P15

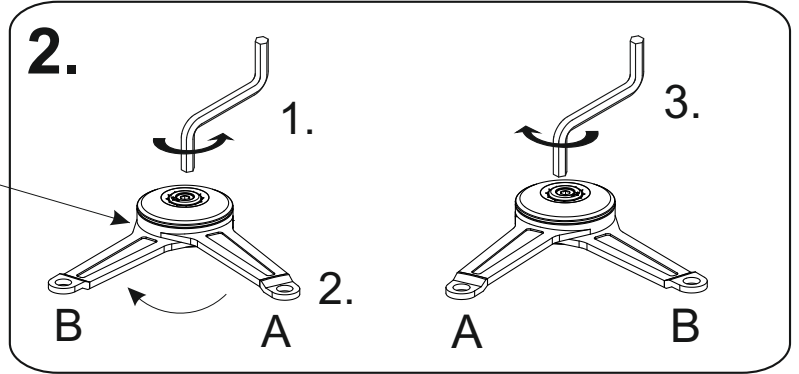

3.

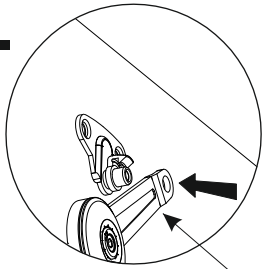

P15

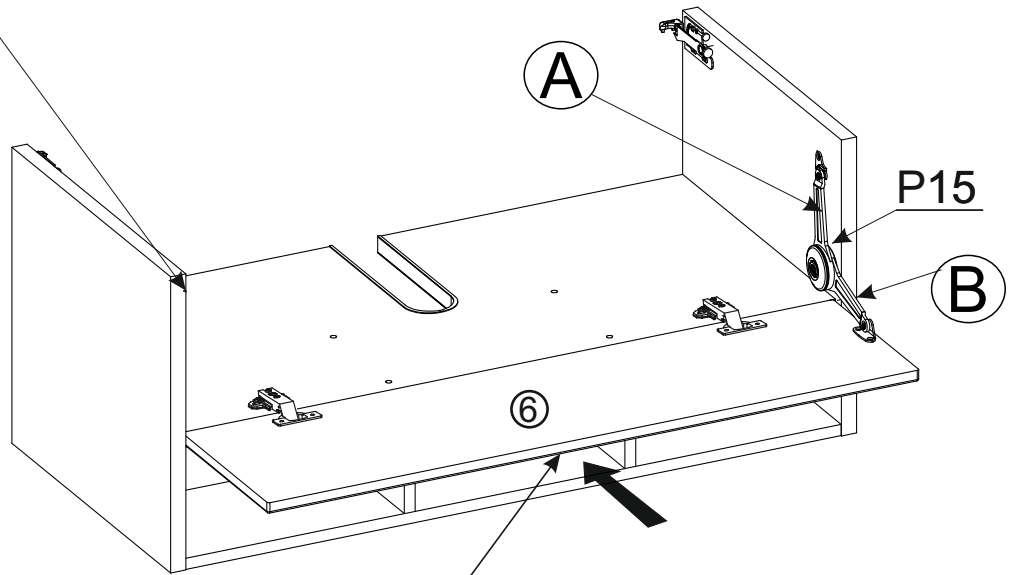
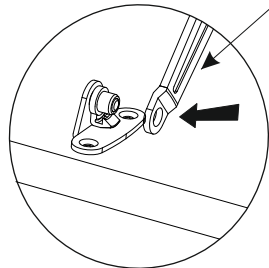

4.

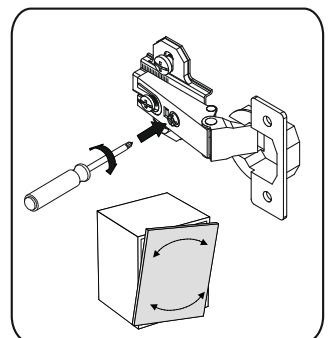
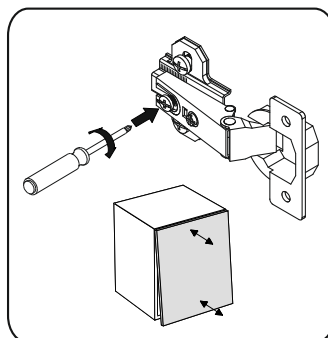
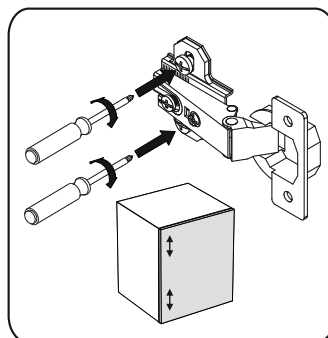
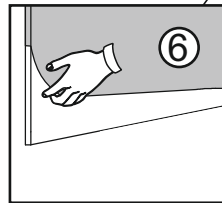
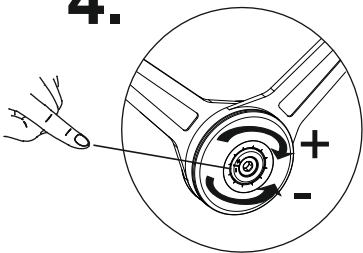

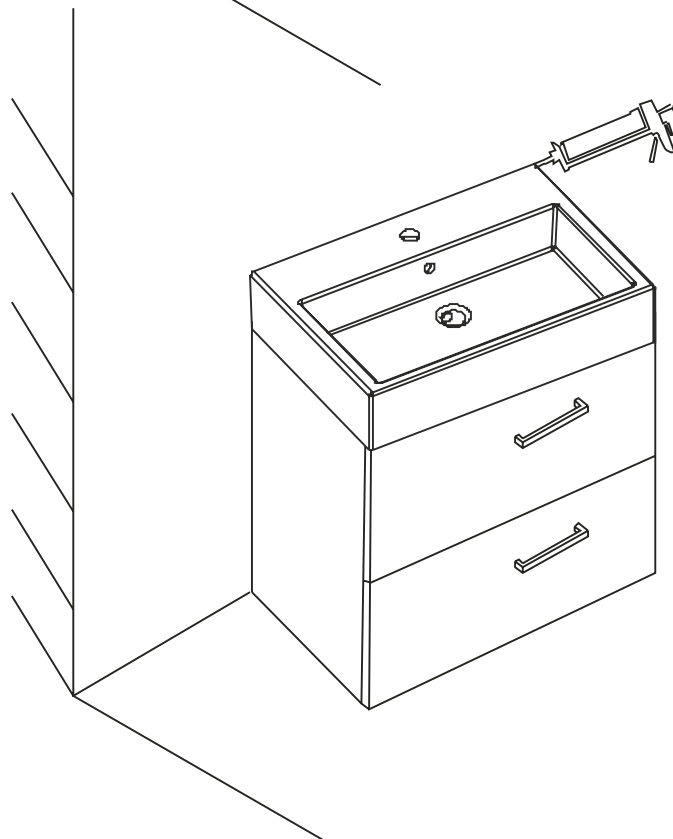
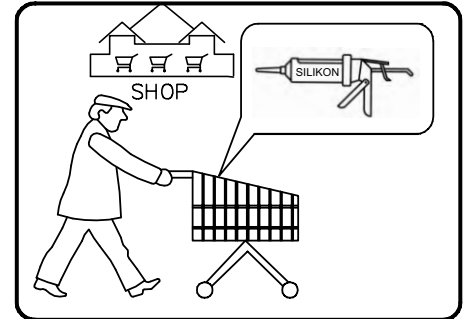
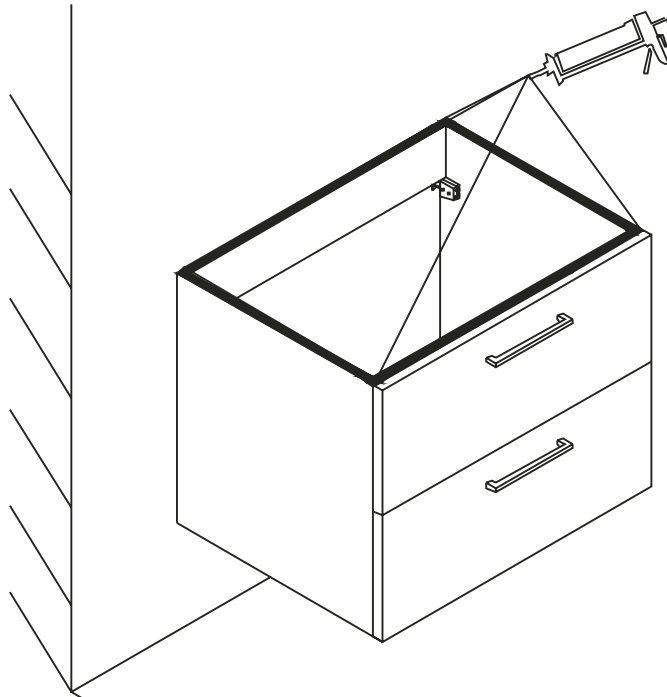
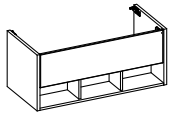

Name • Nom • Nome • Naam • Nazwa • Иméно • Názov • Név • Denumire • Isim • Извание	Nr • No • N° • Номер • Č • Sz	Typ • Type • Tip • Típus • Tipo • Tun
STUDIO LINE	— —	65

Unser Direktservice für Beschlagteile

Sollte Ihnen ein Beschlagteil fehlen, können Sie diese Servicekarte direkt an die untenstehende Adresse mailen. Wir können allerdings nur Beschlagteile auf diesem Wege verschicken. Sollten Sie eine andere Beanstandung an Ihrem Möbelstück haben, so wenden sie sich bitte direkt an Ihr Möbelhaus.

Our direct order service for fitting

If a fitting part is missing, you can e-mail this service card directly to the address below. However, we can only send fitting parts in this way. If you have any other cause for complaint concerning your item of furniture, please contact your furniture store directly.

Naše přímé služby pro kování

Chybí-li vám nějaký díl z kování, můžete tuto servisní kartu odeslat e-mailem přímo na níže uvedenou adresu. Touto cestou však můžeme zoslat jen díly kování. Pokud byste reklamovali jiný díl nábytku, obraťte se přímo na svého prodejce nábytku.

Bien etudier la notice de montage

S'il vous manque une ferrure, veuillez envoyer directement la présente carte service à l'adresse e-mail indiquée ci-dessous. Cependant, ceci nous permet uniquement d'envoyer des ferrures. Pour tout autre type de réclamation concernant votre meuble, veuillez contacter directement votre magasin d'ameublement.

Il nostro servizio diretto per l'ordine della ferramenta

Qualora Vi dovesse mancare un pezzo di fissaggio, allora Vi preghiamo di inviare questa carta di servizio immediatamente all'indirizzo sottostante. Possiamo inviare i pezzi di fissaggio solamente per mezzo di questo procedimento. Qualora dovete avere qualche altra reclamazione in merito al mobile, allora Vi preghiamo di rivolgerVi direttamente al Vostro Negozio di mobili.

Нашата директна услуга за обков

Ако липсват части от комплекта, попълнете настоящата сервисна карта и ни я изпратете на e-mail адреса, посочен по-долу. По този начин можем да доставяме само липсващи елементи от обкова. Ако установите други дефекти по мебелите, Ви съветваме да се обърнете към мебелната къща/магазин, от който сте закупили стоката.

Onze directservice voor losse onderdelen

Wanneer er een onderdeel ontbreekt, kunt u deze servicekaart direct aan onderstaand e-mailadres sturen. Wij kunnen langs deze weg echter alleen beslagdelen versturen. Mocht u een ander probleem aan uw meubel hebben, verzoeken wij u contact op te nemen met uw meubeldealer.

Nasz bezpośredni serwis części montażowych

Jeżeli brakuje części koniecznych do montażu, prosimy o przesłanie nam niniejszej karty serwisowej na niżej podany adres e-mailowy. W ten sposób możemy przesyłać Państwu tylko brakujące części. W przypadku innych reklamacji dotyczących mebla, prosimy zgłosić się do salonu meblowego, w którym został dokonany zakup.

Servis za okove

U slučaju da nedostaje neki od dijelova molimo vas da na dolje navedenu mail adresu pošaljete ovaj servisni obrazac. Na ovaj način mogu se dostaviti samo okovi. U slučaju da imate dodatne prigovore vezane uz komad namještaja molimo vas da se obratite izravno trgovini namještaja gdje je isti kupljen.

Direktszolgálatunk vasalatok esetén

Ha hiányzik egy vasalat, ezt a kártyát közvetlenül elküldheti az alább található címre. Azonban csakis vasalatokat tudunk így küldeni. Amennyiben másfajta reklamáció áll fenn bűtorárábját illetően, forduljon közvetlenül a bűtorházhöz.

Náš priamy servis pre časti kovania

Ak by Vám chýbala nejaká časť kovania, môžete poslať túto servisnú kartu poslať e-mailom na nižšie uvedenú adresu. Diely kovania vieme poslať iba týmto spôsobom. Ak by ste mali inú reklamáciu ohľadom Vášho nábytku, obráťte sa priamo na Vašu predajňu nábytku.

Naše direktne uslužne storitve za okovje

Če vam manjka kakšno okovje, lahko to servisno kartico pošljete po e-pošti direktno na spodnji naslov. Po tej poti vam lahko pošljemo samo okovje. Če želite reklamirati kakšen drug del pohištva, se obrnite neposredno na vašo trgovino pohištva.

Service-ul nostru direct pentru feronerie

În cazul în care vă lipsește o piesă de feronerie puteți să trimiteți direct acest card de service prin e-mail la adresa de mai jos. Noi nu putem expedia piese de feronerie decât pe această cale. Dacă aveți o altă reclamație referitoare la piesa de mobilier, atunci vă rugăm să vă adresați direct la magazinul dvs. de mobilă.

Наш прямой сервис для поставок фурнитуры

Если окажется, что Вам не хватает того или иного элемента фурнитуры, Вы можете отправить сервисную карту по факсу непосредственно на нижеприведенный адрес электронной почты. Однако, таким образом мы можем пересылать лишь фурнитуру. Если же у Вас возникнут иные претензии относительно приобретенной мебели, пожалуйста, обращайтесь непосредственно в организацию, осуществившую продажу.

Vår direktservice för beslagsdelar

Om du saknar en beslagsdel kan du skicka detta servicekort direkt till e-postadressen som anges nedan. Tänk på att detta är den enda möjligheten att skicka beslagsdelar till dig. Om du vill reklamera din möbel av en annan anledning måste du kontakta ditt möbelhus direkt.

Nuestro servicio directo para accesorios

Si le falta algún accesorio, puede enviar esta tarjeta de servicio directamente a la siguiente dirección. No obstante, por este método solo podemos enviar accesorios. Si tiene alguna otra objeción sobre su mueble, consulte directamente con su mueblería.

Donatilar için doğrudan servisimiz

Bir donatınız eksikse bu servis kartını doğrudan aşağıda bulunan adrese doğrudan mail yazabilirsiniz. Sadece bu yolla donatıları gönderebiliriz. Mobilyanızda başka şikayetleriniz varsa lütfen doğrudan mobilya satıcınıza danışın.

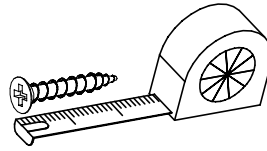

B1 ø8x35 x...	I8 x...	K1 x...
K10 x...	D4 x...	C7 x...
G34 3,5x16 x...	A1 ø7x50 x...	W2 x...
P15 x...	P12 L R x...	
P14 x...	G51 x...	
F10 x...	O3 x...	
P15 x...		

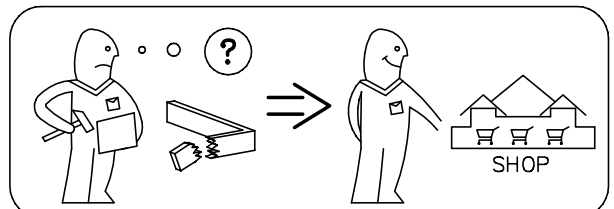
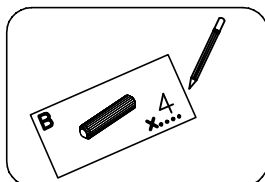

Name • Nom • Nome • Naam • Nazwa • Jméno
• Názov • Név • Denumire • Isim • Имя

Nr • No • N° • Номер • Č • Sz

Typ • Type • Tip • Típus • Tipo • Tun

STUDIO LINE

— —

65

Unser Direktservice für Beschlagteile

D Sollte Ihnen ein Beschlagteil fehlen, können Sie diese Servicekarte direkt an die untenstehende Adresse mailen. Wir können allerdings nur Beschlagteile auf diesem Wege verschicken. Sollten Sie eine andere Beanstandung an Ihrem Möbelstück haben, so wenden Sie sich bitte direkt an Ihr Möbelhaus.

Our direct order service for fitting

GB If a fitting part is missing, you can e-mail this service card directly to the address below. However, we can only send fitting parts in this way. If you have any other cause for complaint concerning your item of furniture, please contact your furniture store directly.

Naše přímé služby pro kování

CZ Chybí-li vám nějaký díl z kování, můžete tuto servisní kartu odeslat e-mailem přímo na níže uvedenou adresu. Touto cestou však můžeme zosílat jen díly kování. Pokud byste reklamovali jiný díl nábytku, obraťte se přímo na svého prodejce nábytku.

Bien etudier la notice de montage

F S'il vous manque une ferrure, veuillez envoyer directement la présente carte service à l'adresse e-mail indiquée ci-dessous. Cependant, ceci nous permet uniquement d'envoyer des ferrures. Pour tout autre type de réclamation concernant votre meuble, veuillez contacter directement votre magasin d'ameublement.

Il nostro servizio diretto per l'ordine della ferramenta

I Qualora Vi dovesse mancare un pezzo di fissaggio, allora Vi preghiamo di inviare questa carta di servizio immediatamente all'indirizzo sottostante. Possiamo inviare i pezzi di fissaggio solamente per mezzo di questo procedimento. Qualora dovete avere qualche altra reclamazione in merito al mobile, allora Vi preghiamo di rivolgerVi direttamente al Vostro Negozio di mobili.

Нашата директна услуга за обков

BG Ако липсват части от комплекта, попълнете настоящата сервисна карта и ни я изпратете на e-mail адреса, посочен по-долу. По този начин можем да доставяме само липсващи елементи от обкова. Ако установите други дефекти по мебелите, Ви съветваме да се обърнете към мебелната къща/магазин, от който сте закупили стоката.

Onze directservice voor losse onderdelen

NL Wanneer er een onderdeel ontbreekt, kunt u deze servicekaart direct aan onderstaand e-mailadres sturen. Wij kunnen langs deze weg echter alleen beslagdelen versturen. Mocht u een ander probleem aan uw meubel hebben, verzoeken wij u contact op te nemen met uw meubeldealer.

Nasz bezpośredni serwis części montazowych

PL Jeżeli brakuje części koniecznych do montażu, prosimy o przesłanie nam niniejszej karty serwisowej na niżej podany adres e-mailowy. W ten sposób możemy przesłać Państwu tylko brakujące części. W przypadku innych reklamacji dotyczących mebla, prosimy zgłosić się do salonu meblowego, w którym został dokonany zakup.

Servis za okove

HR U slučaju da nedostaje neki od dijelova molimo vas da na dolje navedenu mail adresu pošaljete ovaj servisni obrazac. Na ovaj način mogu se dostaviti samo okovi. U slučaju da imate dodatne prigovore vezane uz komad namještaja molimo vas da se obratite izravno trgovini namještaja gdje je isti kupljen.

Direktszolgálatunk vasalatok esetén

HU Ha hiányzik egy vasalat, ezt a kártyát közvetlenül elküldheti az alább található címre. Azonban csakis vasalatoskat tudunk így küldeni. Amennyiben másfajta reklamáció áll fenn bútorárbaját illetően, forduljon közvetlenül a bútorházhoz.

Náš priamy servis pre časti kovania

SK Ak by Vám chýbala nejaká časť kovania, môžete poslať túto servisnú kartu poslať e-mailom na nižšie uvedenú adresu. Diely kovania vieme poslať iba týmto spôsobom. Ak by ste mali inú reklamáciu ohľadom Vášho nábytku, obráťte sa priamo na Vašu predajňu nábytku.

Naše direktne uslužne storitve za okovje

SLO Če vam manjka kakšno okovje, lahko to servisno kartico pošljete po e-pošti direktno na spodnji naslov. Po tej poti vam lahko pošljemo samo okovje. Če želite reklamirati kakšen drug del pohištva, se obrnite neposredno na vašo trgovino pohištva.

Service-ul nostru direct pentru feronerie

RO În cazul în care vă lipsește o piesă de feronerie puteți să trimiteți direct acest card de service prin e-mail la adresa de mai jos. Noi nu putem expedia piese de feronerie decât pe această cale. Dacă aveți o altă reclamație referitoare la piesa de mobilier, atunci vă rugăm să vă adresați direct la magazinul dvs. de mobilă.

Наш прямой сервис для поставок фурнитуры

RUS Если окажется, что Вам не хватает того или иного элемента фурнитуры, Вы можете отправить сервисную карту по факсу непосредственно на нижеприведенный адрес электронной почты. Однако, таким образом мы можем пересылать лишь фурнитуру. Если же у Вас возникнут иные претензии относительно приобретенной мебели, пожалуйста, обращайтесь непосредственно в организацию, осуществившую продажу.

Vår direktservice för beslagsdelar

S Om du saknar en beslagsdel kan du skicka detta servicekort direkt till e-postadressen som anges nedan. Tänk på att detta är den enda möjligheten att skicka beslagsdelar till dig. Om du vill reklamera din möbel av en annan anledning måste du kontakta ditt möbelhus direkt.

Nuestro servicio directo para accesorios

ES Si le falta algún accesorio, puede enviar esta tarjeta de servicio directamente a la siguiente dirección. No obstante, por este método solo podemos enviar accesorios. Si tiene alguna otra objeción sobre su mueble, consulte directamente con su mueblería.

Donatilar için doğrudan servisimiz

TR Bir donatınız eksikse bu servis kartını doğrudan aşağıda bulunan adrese doğrudan mail yazabilirsiniz. Sadece bu yolla donatıları gönderebiliriz. Mobilyanızda başka şikayetleriniz varsa lütfen doğrudan mobilya satıcınıza danışın.

nr	L[mm]	B[mm]	T[mm]	Menge	Colli
1	420	460	22	1	1/1
2	420	460	22	1	1/1
3	950	442	16	1	1/1
4	950	149	16	1	1/1
5	950	459	16	1	1/1
6	944	250	16	1	1/1
7	149	175	16	2	1/1

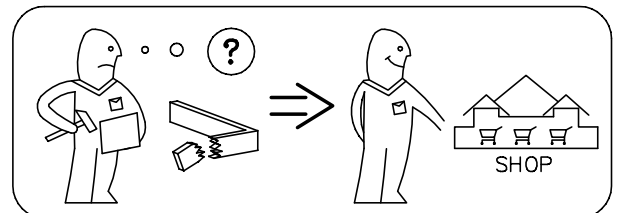
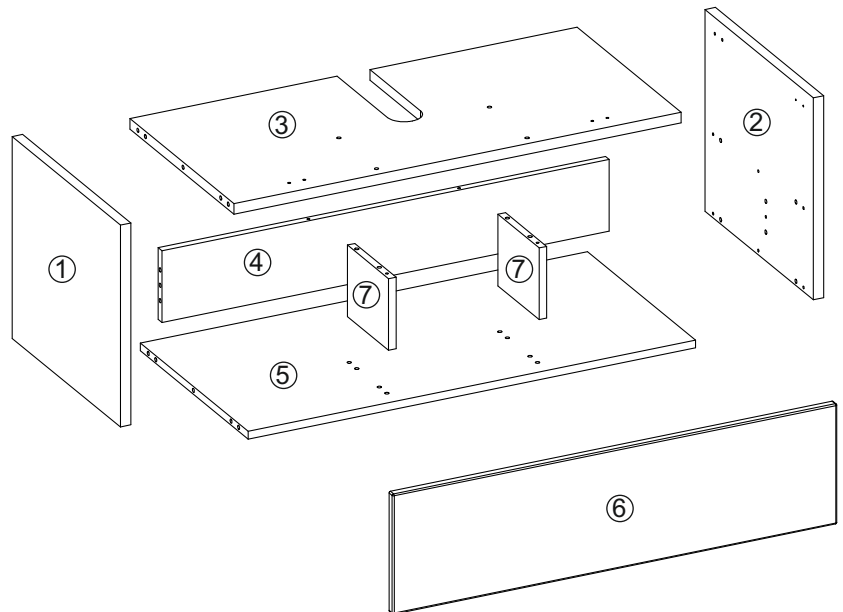

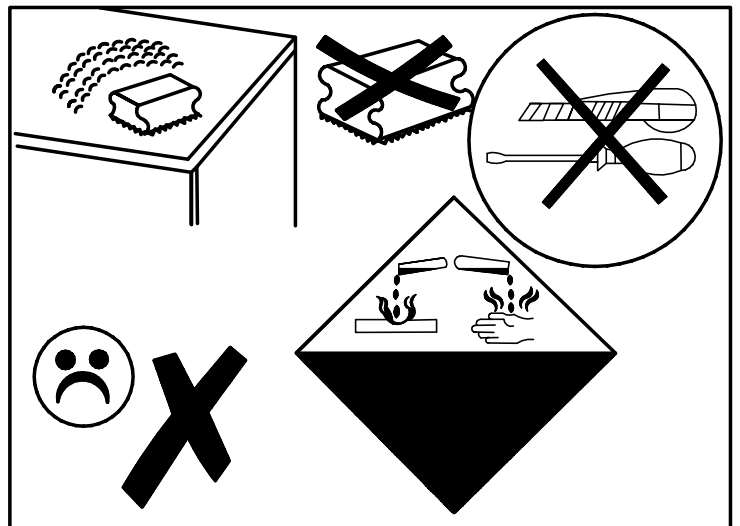
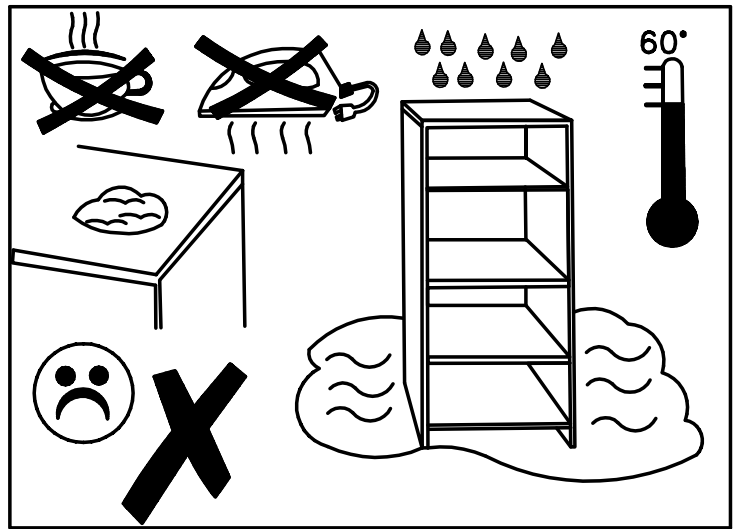
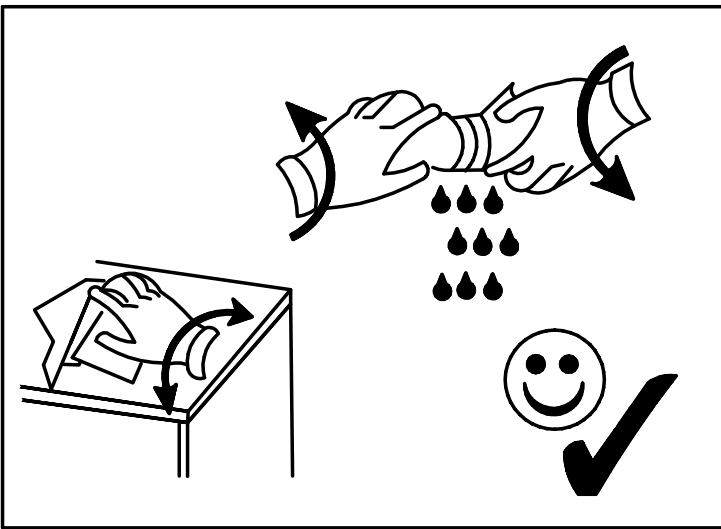
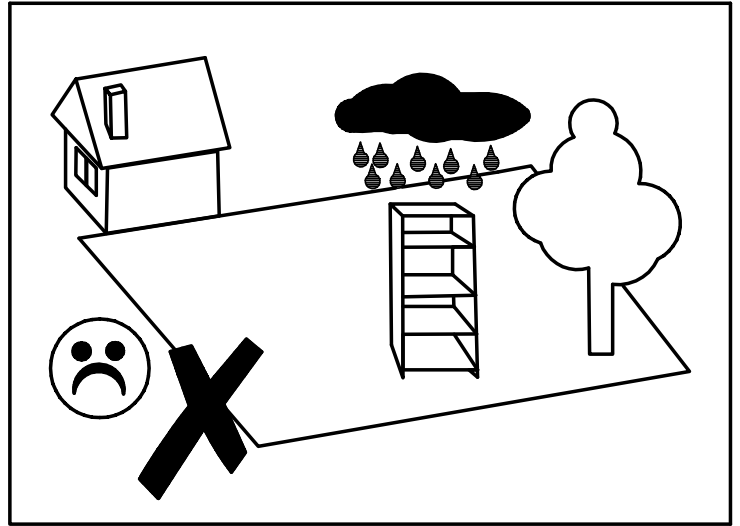
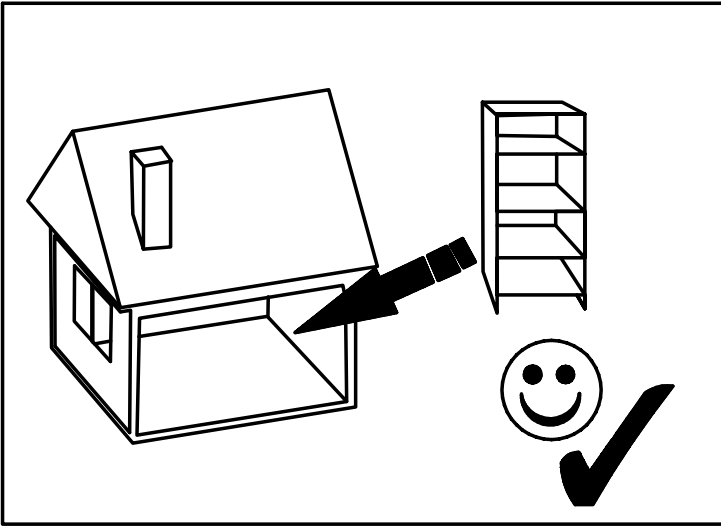

Waschtischbecken BW TB AM 10 00

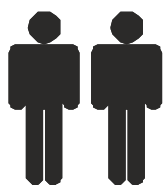

24 h



D Anleitung

NL Handleiding

F Manuel

IT Istruzioni

GB Instruction manual



WASCHBECKEN 100 (465x1004)

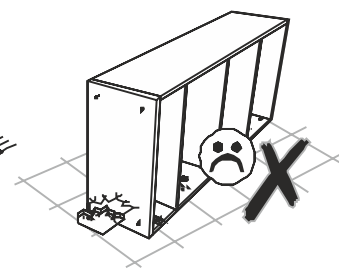
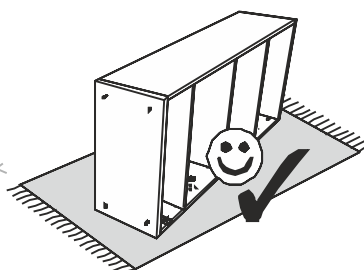
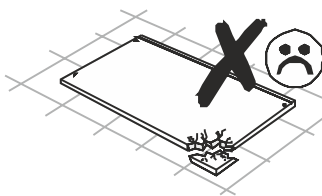
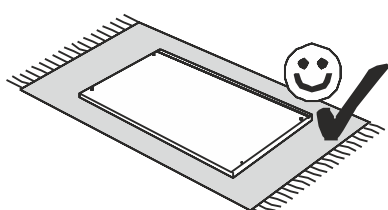
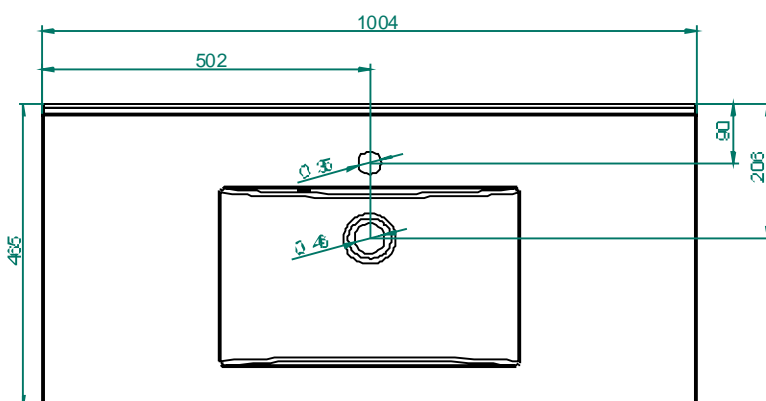
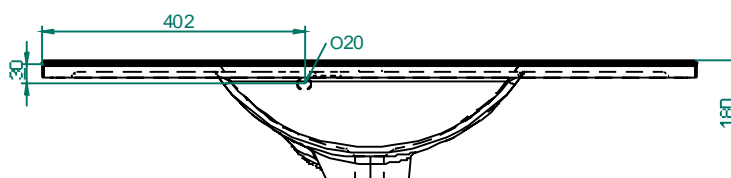

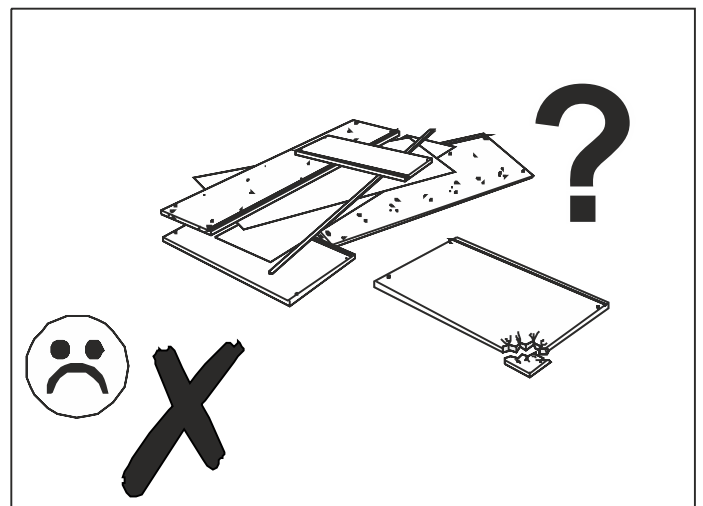
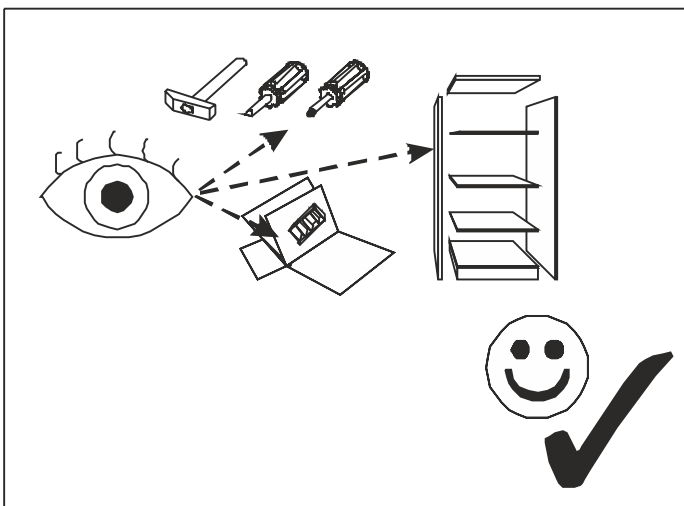
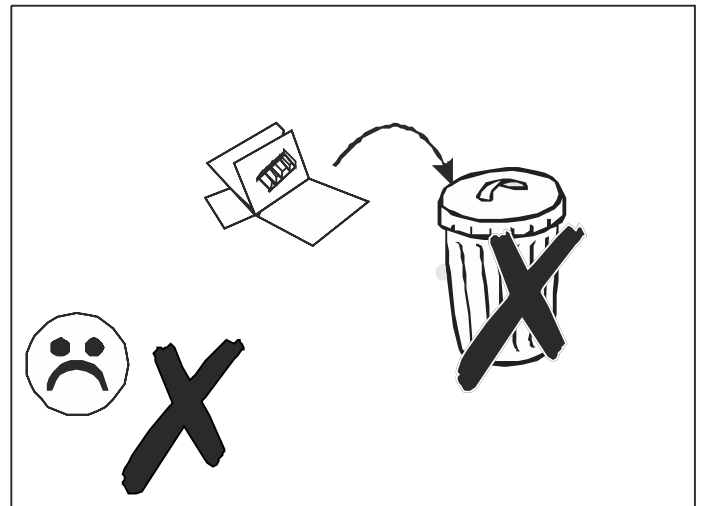
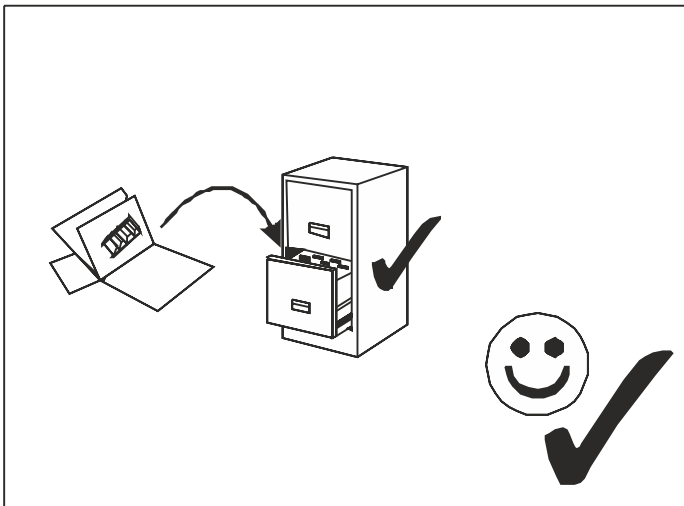
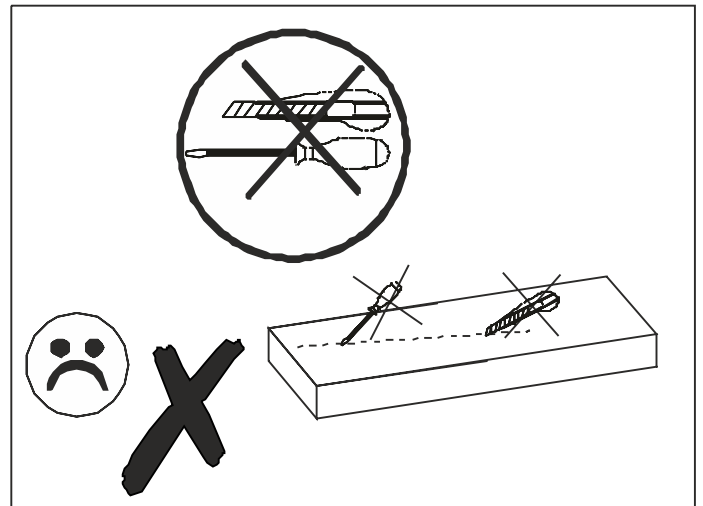
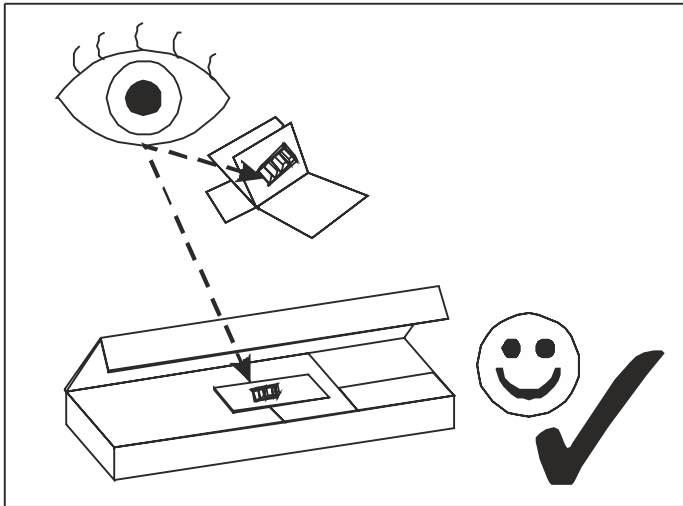

WICHTIG, FÜR SPÄTERE BEZUGNAHME DIESES DOKUMENT AUFBEWAHREN! SORGFÄLTIG LESEN!

Bestimmungsgemäßer Gebrauch

- Diesen Artikel nur für die persönliche Hygiene verwenden. Er ist nicht als Letterersatz, Sitzgelegenheit, Unterstellbock oder Turngerät für Kinder geeignet.
- Dieser Artikel ist nur zum Einsatz im privaten Bereich bestimmt.



Sicherheitshinweise

- **Erstickungs-/ Verletzungsgefahr!** Lassen Sie Kinder nicht mit der Verpackung spielen. Sie könnten an der Folie ersticken oder sich an der Umverpackung verletzen.
- Achten Sie darauf, dass Kinder keine kleinen Teile, wie z. B. Muttern, Abdeckkappen oder Ähnliches in den Mund nehmen. Sie könnten sie verschlucken und daran ersticken.
- Der Artikel darf nur von fachkundigen Personen montiert werden.
- **Verletzungsgefahr!** Der Artikel ist kein Kinderspielzeug. Wenn sich Kinder an den Artikel hängen, könnte er aus der Wand herausgerissen werden und die Kinder könnten sich dabei verletzen.
- Montieren Sie den Artikel nur an einer geeigneten, massiven Wand.
- **Achtung:** Die Befestigung des Möbelstückes an der Wand muss von einer fachkundigen Person vorgenommen werden, da für die Montage an die Wand angepasste Dübel erforderlich sind.
- Stellen Sie sicher, dass sich keine Kabel oder Rohrleitungen in den Bohrbereichen befinden.
- Prüfen Sie die Bereiche vor dem Bohren mit einem Metallsuchgerät.
- Die Materialien zur Wandmontage sind nicht im Lieferumfang enthalten und im Fachmarkt käuflich zu erwerben.

Pflegehinweise

Entfernen Sie Verunreinigungen mit einem leicht angefeuchteten Tuch. Verwenden Sie keinesfalls aggressive oder Lösemittel enthaltende Reinigungsmittel. Diese könnten die Oberflächen beschädigen.

BELANGRIJK, BEWAAREN VOOR LATERE REFERENTIE! ZORGVULDIG DOORLEZEN!

Reglementair gebruik

- Dit artikel enkel voor de persoonlijke hygiëne gebruiken. Het is niet geschikt als vervanging voor een ladder, een opstap of turntoestel voor kinderen.
- Dit artikel is alleen bestemd voor privégebruik.



Veiligheidsinstructies

- **Verstikkings-/ verwondingsgevaar!** Laat kinderen niet met de verpakking spelen. Ze kunnen stikken in de folie of zich aan de verpakking bezeren.
- Zorg ervoor dat kinderen geen kleine stukken, zoals moeren, afdekkapjes of dergelijke in de mond nemen. Ze kunnen ze inslikken en daardoor stikken.
- Het artikel mag alleen door vaklui worden gemonteerd.
- **Gevaar voor verwondingen!** Het artikel is geen speelgoed voor kinderen. Als kinderen aan het artikel gaan hangen, kan het uit de muur worden losgetrokken en de kinderen kunnen zich daarbij bezeren.
- Monteer het artikel alleen op een geschikte, massieve muur.
- **Opgelet:** een vakkundige persoon dient het meubelstuk aan de muur te bevestigen; voor de montage aan de muur zijn immers aangepaste pluggen vereist.
- Controleer of er in de gebieden waar u gaat boren zich geen snoeren of leidingen bevinden.
- Controleer de muren voor het boren met een leidingenzoeker.
- Ondertelen ter bevestiging zijn niet inbegrepen in de levering en moeten in de vakwinkel worden gekocht.

Onderhoud

Verwijder vuil met een licht vochtige doek. Gebruik absoluut geen agressieve of oplosmiddelhoudende reinigingsmiddelen. Deze kunnen de oppervlakken beschadigen.

IMPORTANT : CONSERVER CE DOCUMENT POUR CONSULTATION ULTÉRIEURE ! À LIRE ATTENTIVEMENT !

Usage conforme

- Cet article ne doit être utilisé que pour l'hygiène personnelle. Ne convient pas pour une utilisation comme échelle, pour s'asseoir, comme support ou autre appareil de gymnastique pour enfant.
- Cet article est uniquement destiné à un usage privé.



Consignes de sécurité

- Risque d'asphyxie/de blessure! Ne laissez pas les enfants jouer avec l'emballage. Ils pourraient s'asphyxier avec le film ou se blesser avec les habillages de l'emballage.
- Veillez à ce que les enfants ne mettent aucune petite pièce, comme p. ex. des érous, des capuchons ou similaires, dans la bouche. Ils peuvent les avaler et s'étouffer.
- L'article ne pourra être assemblé que par des personnes s'y connaissant.
- Risque de blessure! L'article n'est pas un jouet. Si des enfants se pendent à l'article, il pourrait alors être arraché du mur et les enfants pourraient se blesser.

- Installez l'article uniquement à un mur massif qui convient.

- Attention : La fixation du meuble contre le mur doit être effectuée par une personne compétente car, pour le montage mural, il faut utiliser des chevilles adaptées.
- Assurez-vous qu'aucun câble ni conduite se trouve dans les endroits où vous percez.
- Avant de percer, vérifiez les endroits avec un appareil de détection du métal.
- Les pièces servant à la fixation ne sont pas fournies. Celles-ci sont en vente dans les magasins spécialisés.

Consignes d'entretien

Enlevez les saletés avec un chiffon légèrement humide. N'utilisez en aucun cas des détergents contenant des produits agressifs ou des solvants. Ceux-ci pourraient endommager les surfaces.

IMPORTANTE: CONSERVARE QUESTO DOCUMENTO PER LA SUCCESSIVA CONSULTAZIONE! LEGGERE ATTENTAMENTE!

Utilizzo conforme alla destinazione d'uso

- Utilizzare questo articolo solo per l'igiene personale.
- Il presente articolo è destinato soltanto all'uso in ambito domestico.



Norme di sicurezza

- Pericolo di soffocamento/di lesioni! Non permettere ai bambini di giocare con l'imballaggio. Correranno il rischio di soffocamento a causa delle pellicole, o di lesioni a causa dell'imballaggio esterno.

- Assicurarsi che i bambini non portino alla bocca le parti piccole, ad es. dadi, coperchietti e simili. Potrebbero ingerirle e soffocare.

- L'articolo può essere montato solo da persone esperte.

- Pericolo di lesioni! L'articolo non è un giocattolo. Se i bambini vi si appendono, potrebbe staccarsi dalla parete e provocare lesioni.

- Montare l'articolo solo una parte idonea, massiccia.

- Attenzione: Il fissaggio del mobile alla parete deve essere eseguito da persone esperte, dato che occorrono tasselli adeguati.

- Assicurarsi che sui punti da trapanare non scorrano cavi o tubazioni.

- Prima di trapanare, ispezionare le zone interessate con un carica-matelli.

- Le parti per il fissaggio non sono contenute nella fornitura e si possono acquistare nei negozi specializzati.

Istruzioni di manutenzione

Rimuovere lo sporco con un panno leggermente umido. In nessun caso utilizzare detergenti aggressivi o a base di solventi, perché potrebbero intaccare le superfici.

IMPORTANT! KEEP THIS DOCUMENT FOR FUTURE REFERENCE! READ CAREFULLY!

Intended use

- This article is only meant to be used for personal hygiene. It is not intended for use as a ladder, seat, support or play equipment for children.
- This item is suitable for domestic use only.



Safety instructions

- Risk of suffocation/injury! Do not allow children to play with the packaging. They could suffocate in the packaging film or injure themselves on the outer packaging.
- Ensure that children do not put any small parts such as nuts, caps or the like in their mouth. They could swallow and choke on them.
- The item should be assembled by competent persons only.
- Risk of injury! This item is not a toy. If children hang from this item it could pull free from the wall and cause injury.
- Mount this item on a suitable wall surface only.

- Attention: A qualified professional is required when mounting furniture to the wall since dowels corresponding to the wall are required for this.

- Ensure that there are no cables or pipes where the holes are to be drilled.

- Check the area before drilling with a metal detector device.

- Installation accessories are not included and need to be purchased from a specialist retailer.

Care information

Clean with a damp cloth. Never use any aggressive cleaning product or those containing solvents. These may damage the surface.

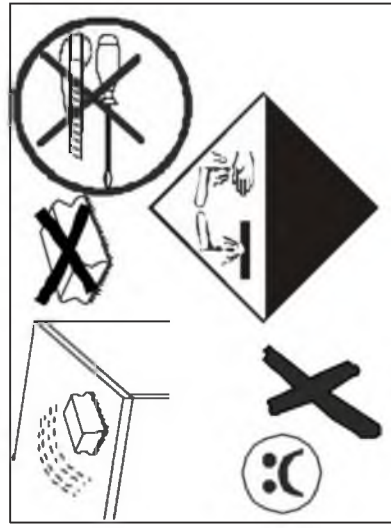
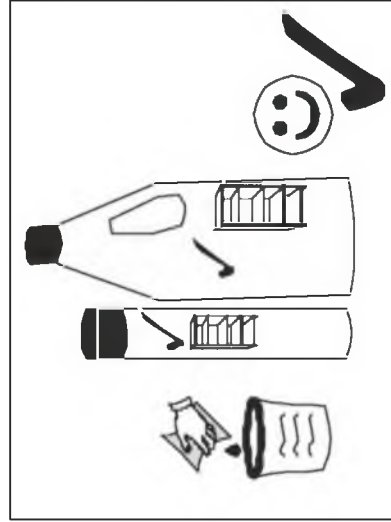
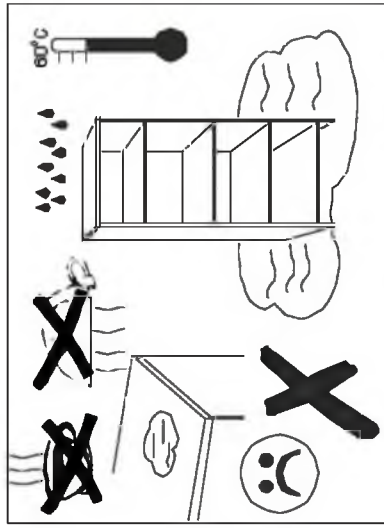
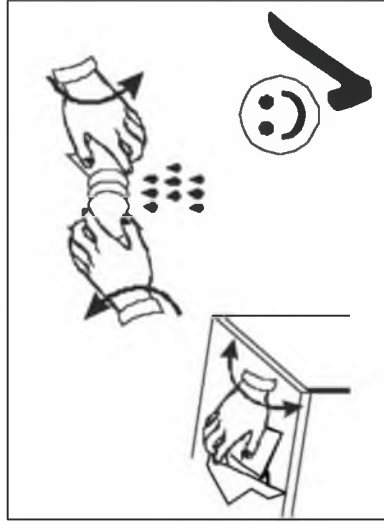
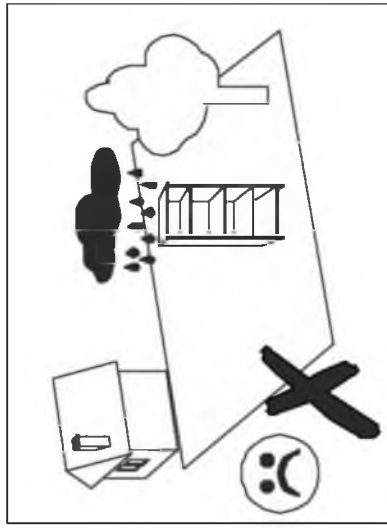
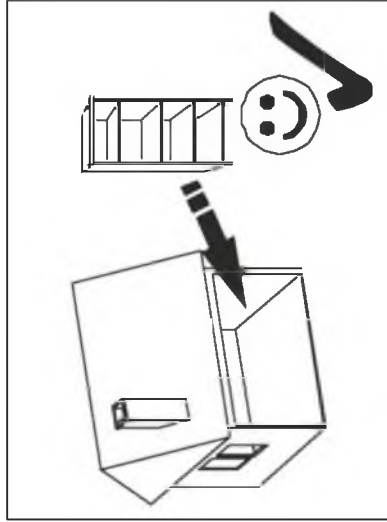
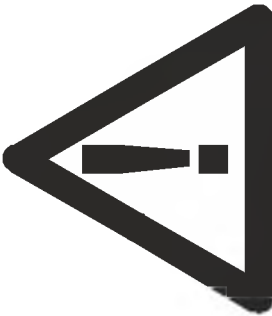

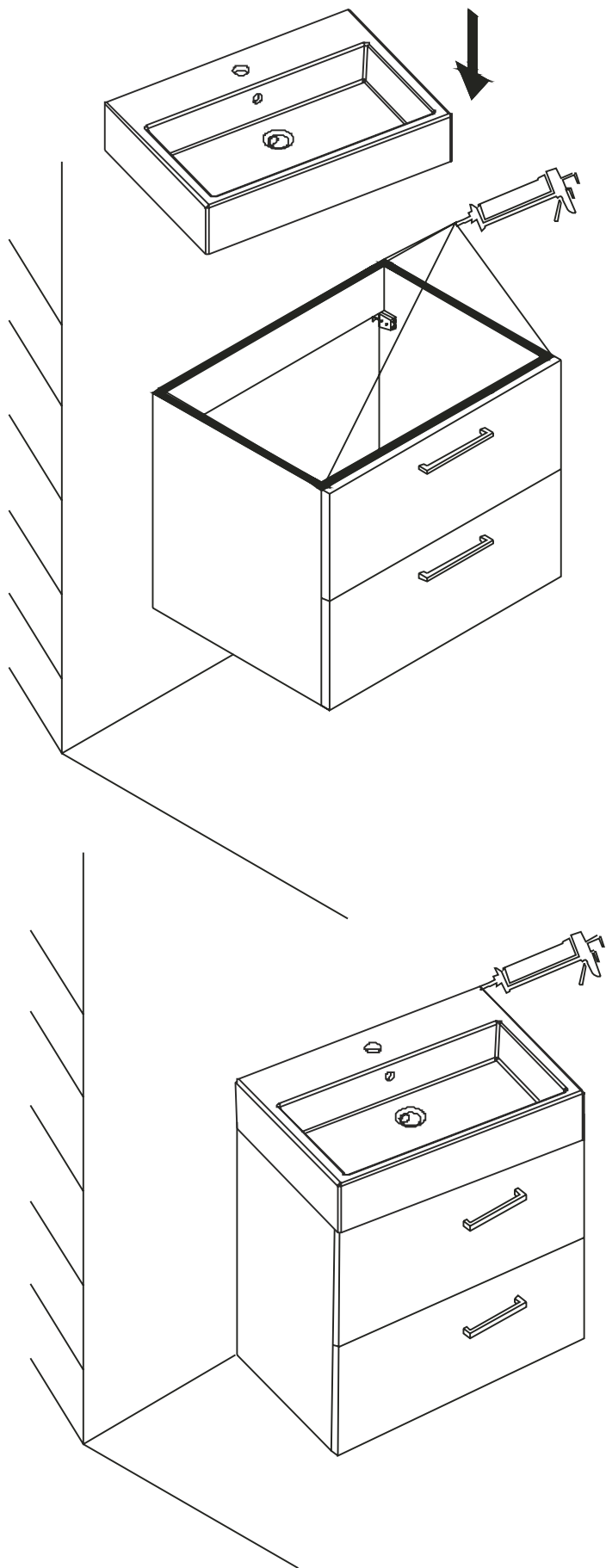

SP 1 MIRROR LED 100x65x3cm

	6300K	ON OFF	15 000	30 000h	<1s	1000x650x30 [mm]
	12,1 kWh/1000h	INPUT: 100-240V~50/60Hz		OUTPUT: 12VDC		
LED: U _{IN} :12VDC I _{IN} :0,9A P _{IN} :11,0W						

Montować tylko w strefie 3 | Mount only in zone 3 | Nur in Zone 3 montieren

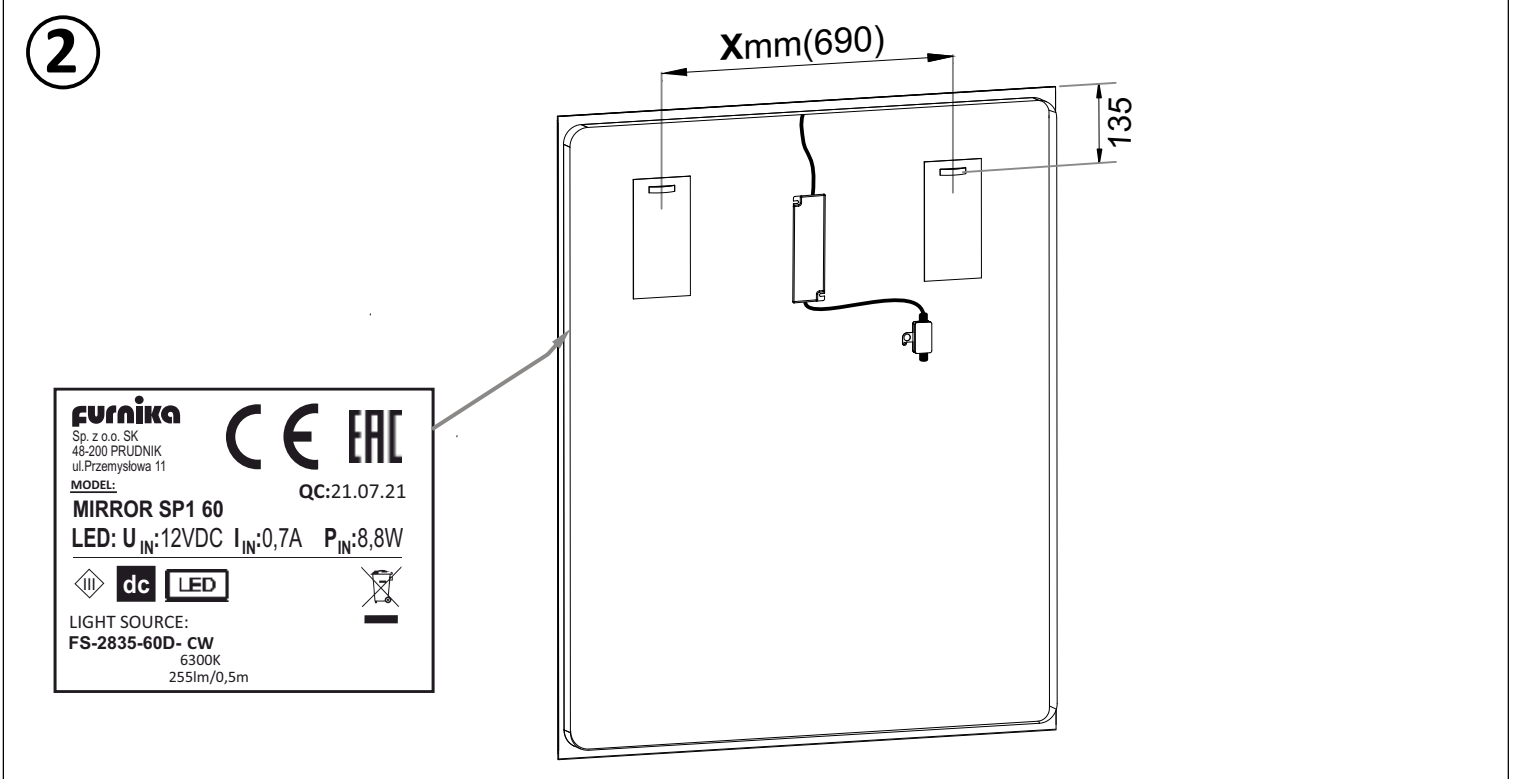
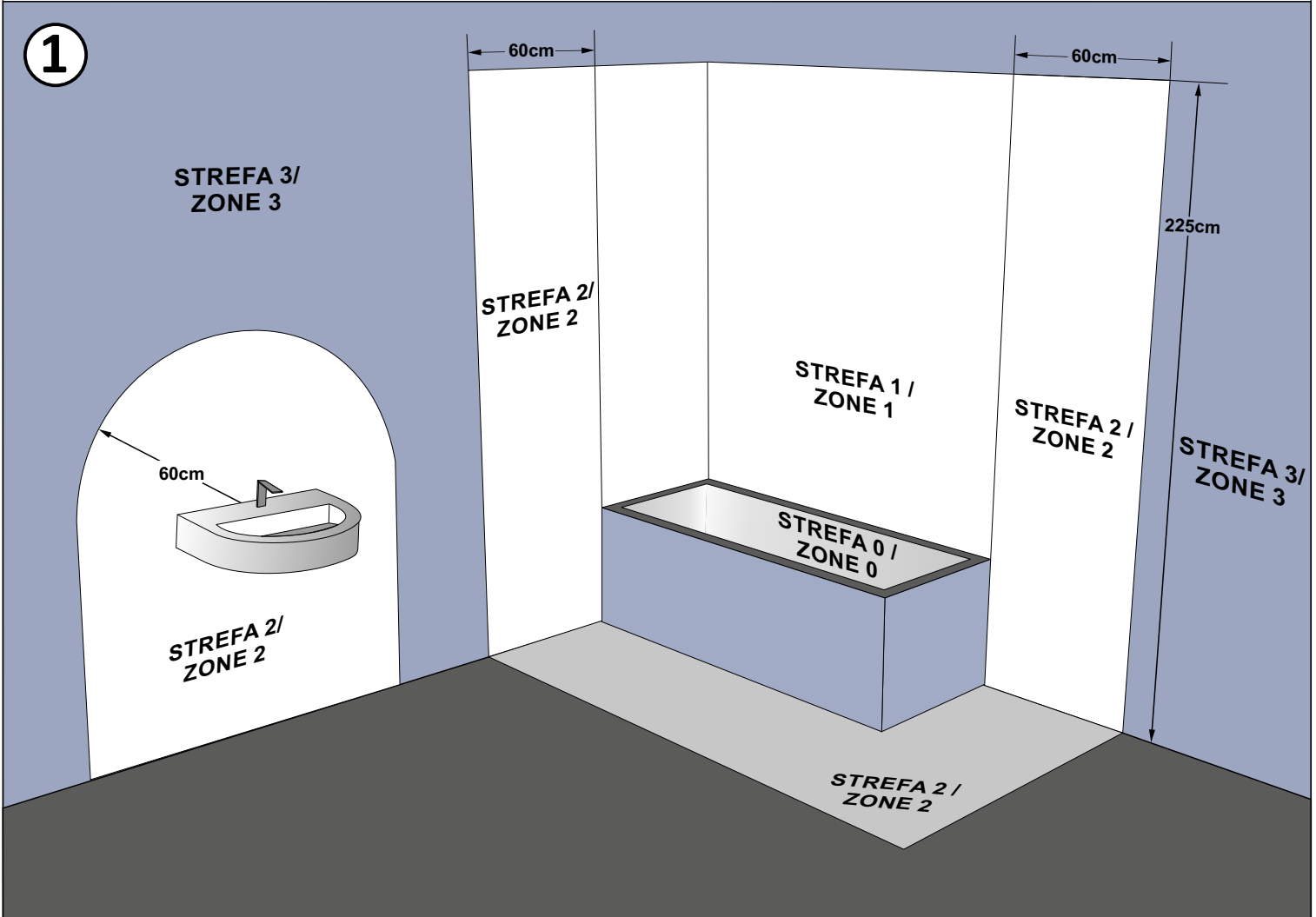

SP 1 MIRROR LED 100x65x3cm

<p>6300K</p>	<p>ON OFF</p>	<p>15 000</p>	<p>30 000h</p>	<p><1s</p>	<p>1000x650x30</p>
	<p>E</p>	<p>kWh/1000h</p> <p>12,1</p>	<p>INPUT: 100-240V~50/60Hz</p> <p>OUTPUT: 12VDC</p> <p>LED: U_{IN}:12VDC I_{IN}:0,9A P_{IN}:11,0W</p>		

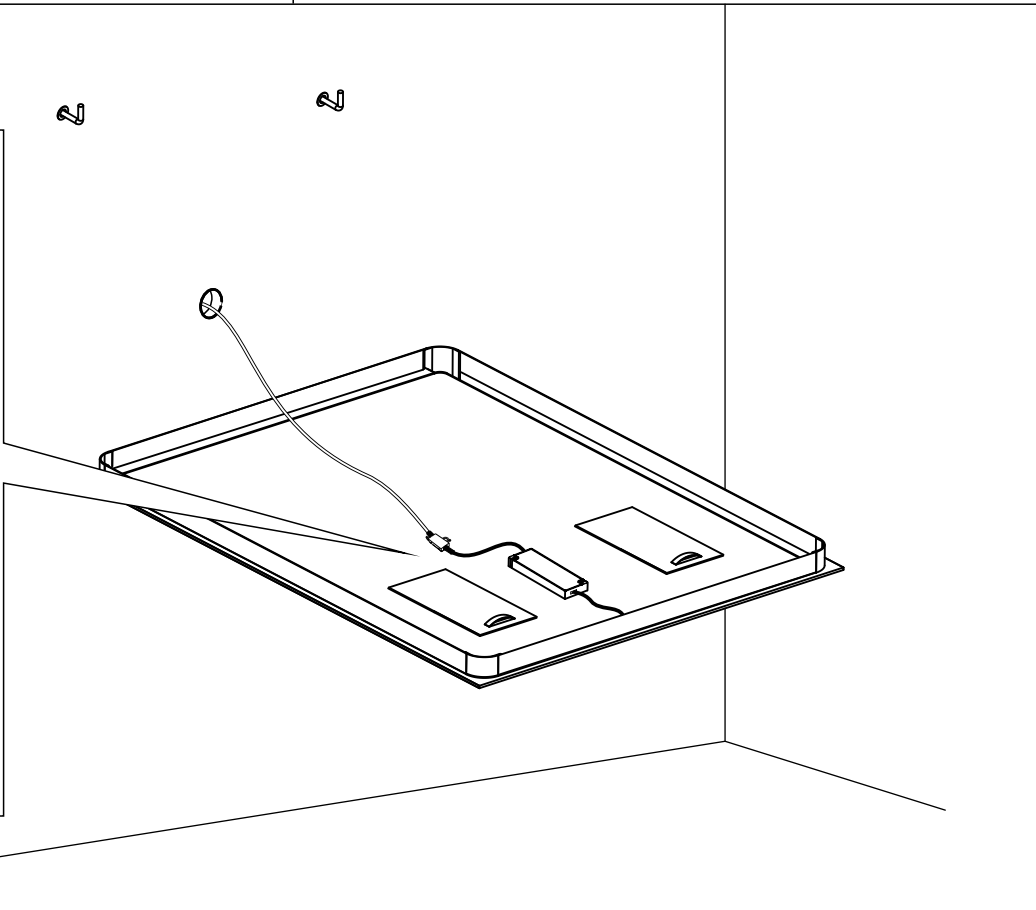
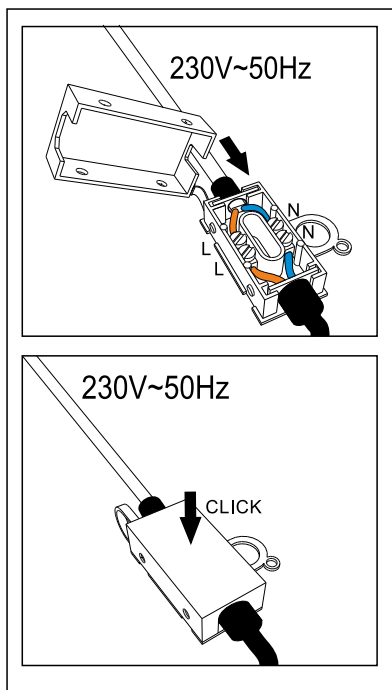
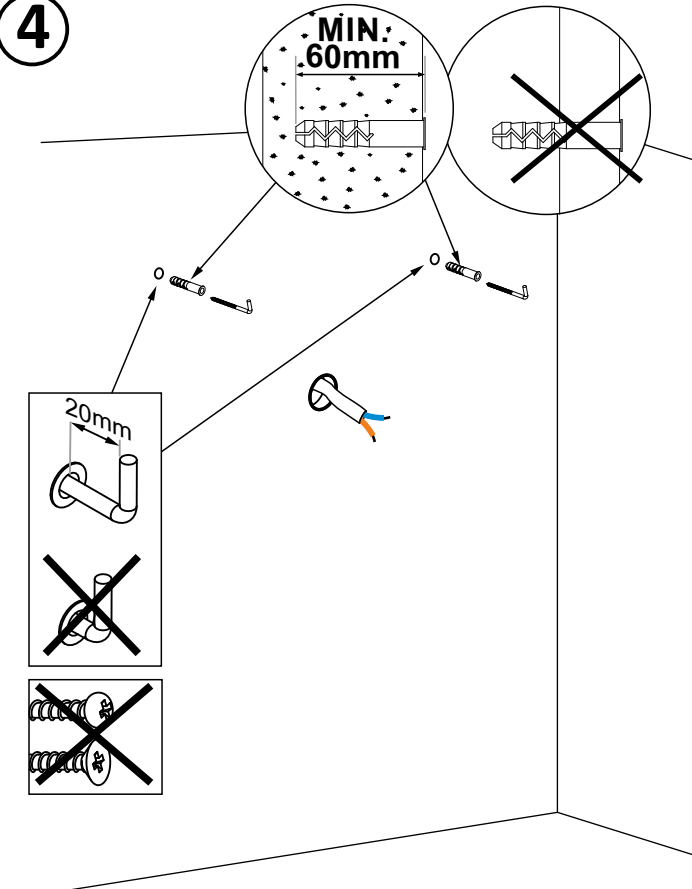
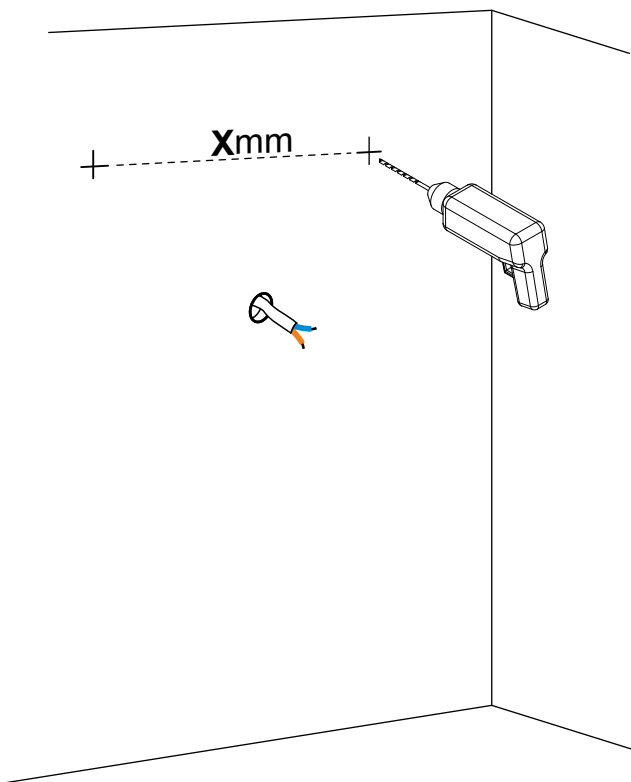
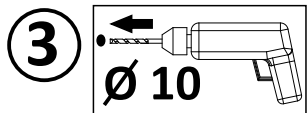

SP 1 MIRROR LED 100x65x3cm

ERAC		CE	IP21	LED	
	6300K	ON OFF 15 000	 30 000h	 <1s	
	E	kWh/1000h 12,1	INPUT: 100-240V~50/60Hz OUTPUT: 12VDC LED: U _{IN} :12VDC I _{IN} :0,9A P _{IN} :11,0W		

6

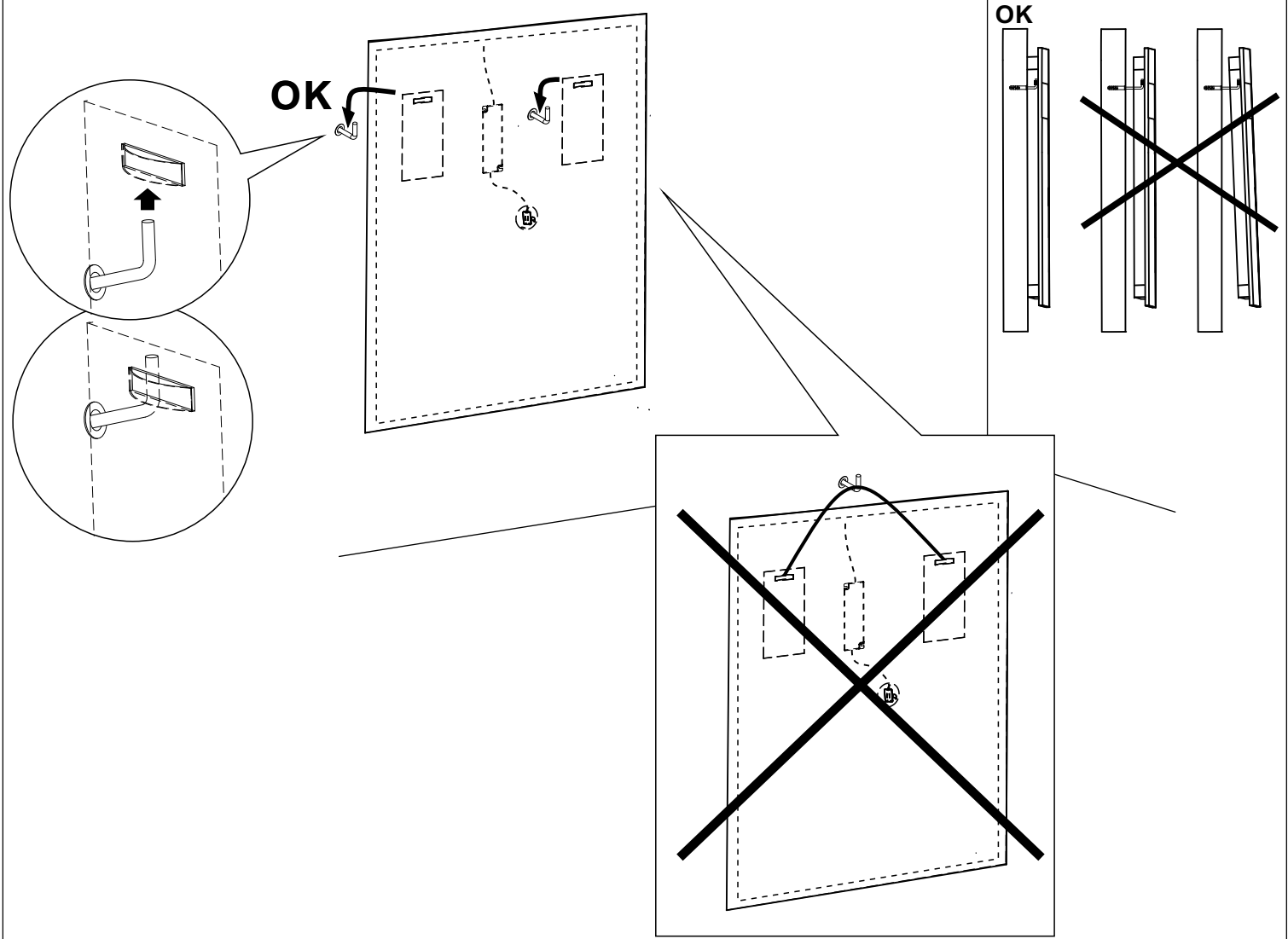

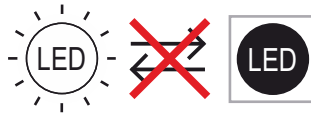

PL - Te produkty wyposażone zawierają źródła światła, które nie mogą być wymienione przez użytkownika końcowego	DE - Diese Produkte enthalten Lichtquellen, die von den Endbenutzer nicht ausgetauscht werden können.	CS - Výrobky obsahující produkty obsahují světelné zdroje, které koncový uživatel nemůže nahradit.
DA - Produkter, der indeholder produkter, indeholder lyskilder, der ikke kan erstattes af slutbrugeren.	EL - Αυτό που περιέχουν προϊόντα περιέχουν πηγές φωτός που δεν μπορούν να αντικατασταθούν από τον τελικό χρήστη.	EN - Those containing products contains a light sources that can not be replaced by the end user.
ES - Aquellos que contienen productos contienen fuentes de luz que no pueden ser reemplazadas por el usuario final.	ET - Tooted sisaldavad valgusallikaid, mida lõpptarbijaja ei saa asendada.	FI - Tuotteita sisältävät valonlähteet, joita loppukäyttäjää ei voi korvata.
FR - Ceux contenant des produits contiennent une source lumineuse qui ne peut pas être remplacée par l'utilisateur final.	HU - A termékeket tartalmazó fényforrások olyan fényforrások tartalmazzak, amelyek a végfelhasználó nem cserélhet ki.	IT - Quelli contenenti prodotti contengono sorgenti luminose che non possono essere sostituite dall'utente finale.
LT - Tuose produktuose yra šviesos šaltinių, kurių negali pakeisti galutinis vartotojas.	LV - Tajos, kas satur produktus, ir gaismas avoti, kurus gala lietotājs nevar aizstāt.	RU - Те, которые содержат продукты, содержат источники света, которые не могут быть заменены конечным пользователем.
PT - Aqueles que contém produtos contém fontes de luz que não podem ser substituídas pelo usuário final.	RO - Cele care conțin produse conțin o sursă de lumină care nu poate fi înlocuită de utilizatorul final.	NL - Die producten bevatten een lichtbron die niet door de eindgebruiker kan worden vervangen.
SK - Výrobky obsahujúce výrobky obsahujú svetelné zdroje, ktoré koncový používateľ nemôže vymeniť.	SLO - Tisti, ki vsebujejo izdelke, vsebujejo svetlobne vire, ki jih končni uporabnik ne more nadomestiti.	SV - De som innehåller produkter innehåller ljuskällor som inte kan ersättas av slutanvändaren.
TR - Ürün içerenerler, son kullanıcı tarafından değiştirilemeyecek bir ışık kaynağı içerir.	HR - Oni koji sadrže proizvode sadrže izvore svjetlosti koje krajnji korisnik ne može zamijeniti.	BG - Тези, които съдържат продукти, съдържат източници на светлина, които не могат да бъдат заменени от крайния потребител.

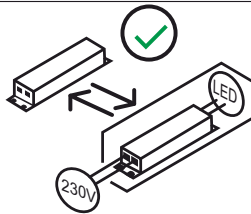

PL - Ten produkt wyposażony zawiera oddzielny osprzęt sterujący, który może być wymieniony przez użytkownika końcowego.	DE - Dieses Produkt enthält ein separates Steuerung Zubehör, dass durch den Endbenutzer ausgetauscht werden kann.	CS - Tento produkt obsahuje samostatné ovládací zařízení, které může koncový uživatel vyměnit.
DA - Dette produkt indeholder separat kontroludstyr, der kan udskiftes af slutbrugeren.	EL - Αυτό το προϊόν περιέχει ξεχωριστό εργαλείο ελέγχου που μπορεί να αντικατασταθεί από τον τελικό χρήστη.	EN - This containing product contains separate control gear that can be replaced by the end user.
ES - Este producto contenedor contiene equipos de control separados que pueden ser reemplazados por el usuario final.	ET - See toode sisaldab eraldi juhtseadmeid, mida lõppkasutaja saab asendada.	FI - Tämä tuote sisältää erillisen ohjaukslaitteen, jonka loppukäyttäjää voi vaihtaa.
FR - Ce produit contenant contient un équipement de commande séparé qui peut être remplacé par l'utilisateur final.	HU - Ez a termék külön vezérlőberendezést tartalmaz, amelyet a végfelhasználó kicserélhet.	IT - Questo prodotto contenente contiene apparecchiature di controllo separate che possono essere sostituite dall'utente finale.
LT - Šiame produkte yra atskira valdymo įranga, kurią gali pakeisti galutinis vartotojas.	LV - Šajā saturšajā produktā ir atsevišķs vadības aprīkojums, kuru gala lietotājs var nomainīt.	RU - Этот содержащий продукт содержит отдельный механизм управления, который может быть заменен конечным пользователем.
PT - Este produto contém acessórios de controle separados que podem ser substituídos pelo usuário final.	RO - Acest produs care conține conține unelte de control separate care pot fi înlocuite de utilizatorul final.	NL - Dit bevattende product bevat aparte voorschakelapparatuur die door de eindgebruiker kan worden vervangen.
SK - Tento produkt obsahuje samostatný predradník, ktorý môže koncový užívateľ vymeniť.	SLO - Ta izdelek vsebuje ločeno krmilno opremo, ki jo lahko zamenja končni uporabnik.	SV - Denna innehållande produkt innehåller separat styrutrustning som kan bytas ut av slutanvändaren.
TR - Bu ürün için ürün, son kullanıcı tarafından değiştirilebilen ayrı bir kontrol tertibatı içerir.	HR - Ovaj proizvod koji sadrži sadrži zasebnu upravljačku opremu koju krajnji korisnik može zamijeniti.	BG - Този съдържащ продукт съдържа отделни контролни уреди, които могат да бъдат заменени от крайния потребител.

PL - Ten produkt zawiera źródła światła o klasie efektywności energetycznej „E”	DE - Diese Produkte enthalten Lichtquellen der Energieeffizienzklasse „E”	CS - Tento výrobek obsahuje světelný zdroj třídy energetické účinnosti „E”
DA - Dette produkt indeholder en lyskilde til energieffektivitetsklasse „E”	EL - Αυτό το προϊόν περιέχει μια πηγή φωτεινής πηγής ενεργειακής απόδοσης „E”	EN - This product contains a light sources of energy efficiency class „E”
ES - Este producto contiene una fuente de luz de clase de eficiencia energética „E”	ET - See toode sisaldab efektiivsusklassi valgusallikat energia „E”	FI - Tämä tuote sisältää energiatehokkuusluokan valonlähteen „E”
FR - Ce produit contient des sources lumineuses de classe d'efficacité „E”	HU - Ez a termék energiatékonysági osztályú fényforrást tartalmaz „E”	IT - Questo prodotto contiene una sorgente luminosa di classe di efficienza energetica „E”
LT - Šiame gaminyje yra energijos vartojimo efektyvumo klasės šviesos šaltinis „E”	LV - Šis produkts satur gaismas avotu ar energoefektivitātes klasi „E”	RU - Этот продукт содержит источник света класса энергоэффективности „E”
PT - Este produto contém uma fonte de luz da classe de eficiência energética „E”	RO - Acest produs conține o sursă de lumină de clasă de eficiență energetică „E”	NL - Dit product bevat een lichtbron met energie-efficiëntieklasse „E”
SK - Tento výrobok obsahuje svetelný zdroj triedy energetickej účinnosti „E”	SLO - Ta izdelek vsebuje svetlobni vir razreda energijske učinkovitosti „E”	SV - Denna produkt innehåller en ljuskälla för energieffektivitetsklass „E”
TR - Bu ürün bir ışık kaynağı enerji verimliliği sınıfı içerir „E”	HR - Ovaj proizvod sadrži izvor svjetlosti razreda energetske učinkovitosti „E”	BG - Този продукт съдържа източник на светлина от клас на енергийна ефективност „E”

PL - Źródło światła oraz oddzielny osprzęt sterujący mogą zostać wyjęte bez trwałego ich uszkodzenia do celów weryfikacji przez organy nadzoru rynku. Instrukcja dotycząca tej czynności znajduje się w dokumentacji technicznej produktu	DE - Die Lichtquellen und die separaten Steuerung Geräte können zu Überprüfung durch die Markt Überwachung Behörde rausgenommen werden ohne sie dauerhaft zu beschädigen. Anweisungen dazu finden Sie in der technischen Dokumentation des Produkts.	EN - The light source and separate control gear can be removed without permanently damaging them for verification by the market surveillance authorities. Instructions on how to do this can be found in the product's technical documentation.
FR - La source lumineuse et les appareils séparés peuvent être retirés sans les endommager de façon permanente pour vérification par les autorités de surveillance du marché. Vous trouverez des instructions sur la façon de procéder dans la documentation technique du produit.	IT - La sorgente luminosa e le apparecchiature di controllo separate possono essere rimosse senza danneggiarle in modo permanente per la verifica da parte delle autorità di vigilanza del mercato. Le istruzioni su come eseguire questa operazione sono disponibili nella documentazione tecnica del prodotto.	RU - Источник света и отдельный пускорегулирующий аппарат могут быть сняты, не повреждая их, для проверки органами надзора за рынком. Инструкции о том, как это сделать, можно найти в технической документации продукта.