



(D) Videounterstützte Montageanleitung

(TR) Video destekli kurulum talimatları

(RU) инструкция по монтажу с помощью видеосигнала

(RO) Instrucțiuni de instalare acceptate video

(GB) Video-assisted assembly instructions

(IT) Istruzioni di montaggio video-assistite

(CZ) Instalační pokyny podporované videem

(PL) Instrukcje montażu wspomagane sygnałem wizyjnym

(FR) Instructions de montage assistées par vidéo

(NL) Video-ondersteunde montage-instructies

(HU) Video-támogatott telepítési utasítások

(SK) Inštalčné pokyny podporované videom

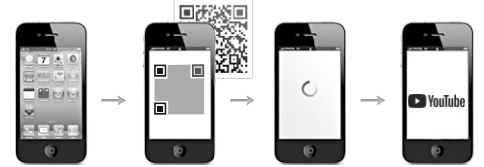

Montageanleitungs.-Nr.:

**MA1-00147**

# Beistellschrank

REPC-Nr.:

Service • Assistenza • Dienstverlening • Serwis  
Servis • Szerviz • Сервисная служба

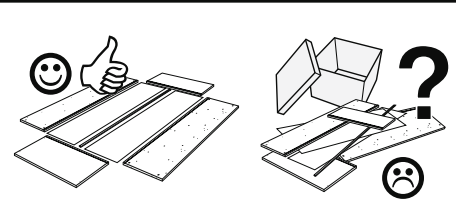
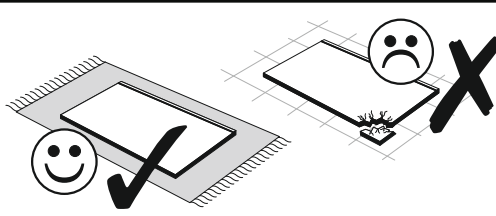
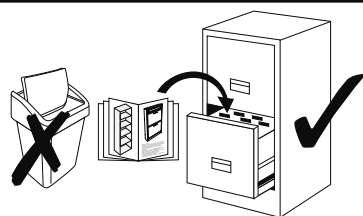
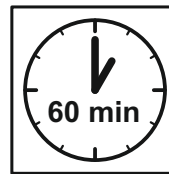
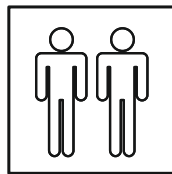
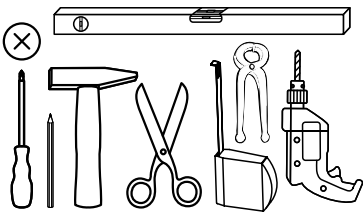

SCAN ME

Das Ersatzteil-Anforderungsformular finden Sie auf  
The replacement parts requisition form you find on  
<https://www.maeusbacher.de/ersatzteile/>

## BT1-00389 Colli 1/2

B02-10 26x ø15x12mm	B02-20 30x	B02-103 12x 8x30
B01-30 21x 3x16	B01-10 10x 6,3x50	B01-175 4x 4,5x60
B02-160 12x	B02-08 4x ø15x10mm	B01-70 2x 3x30
B01-329 4x M4x22	B01-200 4x 6,3x13	B01-37 1x 4,5x25
B01-80 4x 3,5x13	B08-80 1x	

## BT1-00228 Colli 1/2

B03-43 2x	B03-11 2x
B03-07 1x	



▶ SCAN ME

## BT1-00390 Colli 1/2

B05-02 8x ø20mm	B05-02 K1002 2x ø20mm
B05-130 1x Leim	B06-440 2x

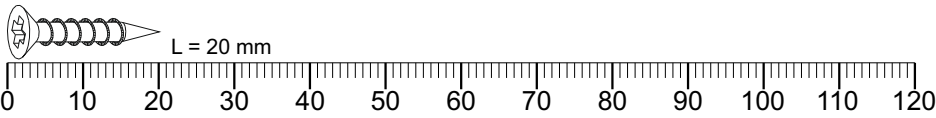

## Colli 1/2

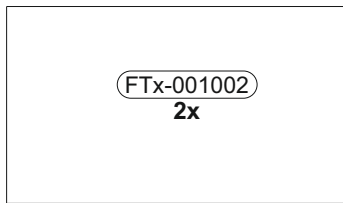

226 x 389

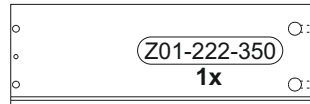

350 x 120

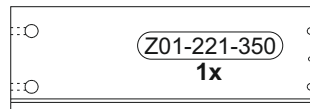

350 x 120

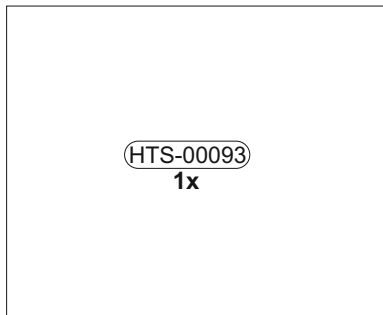
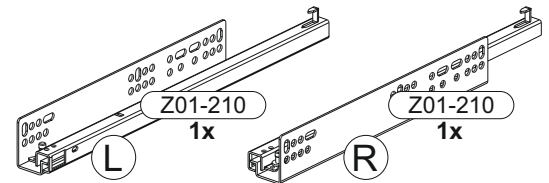

436 x 358

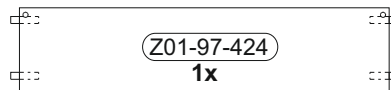

424 x 97

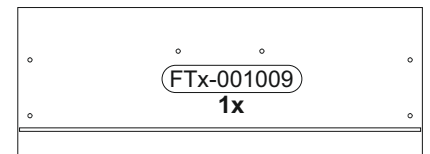

464 x 172

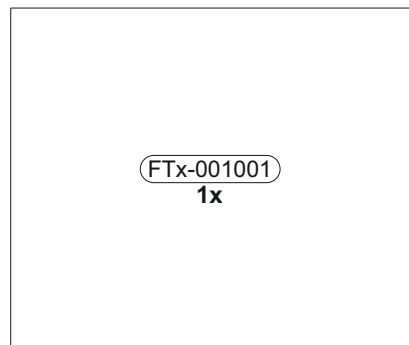

468 x 390

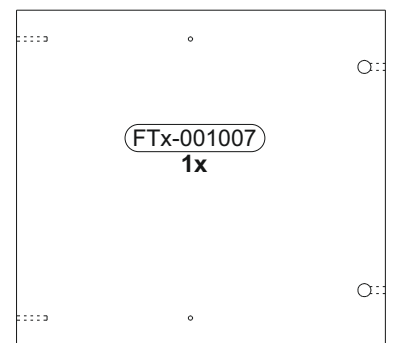

423 x 390

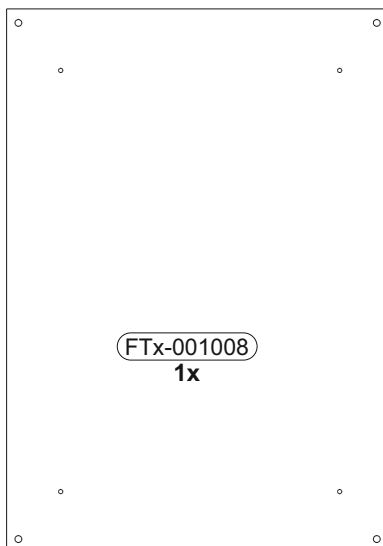

624 x 439

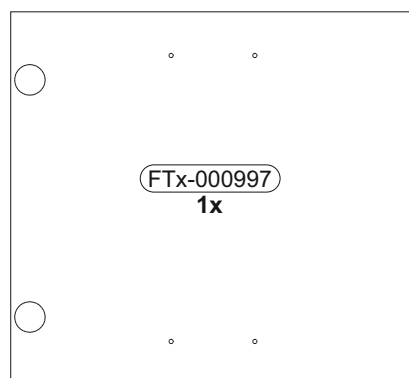

428 x 464

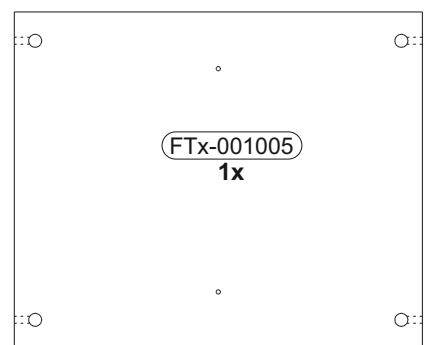

468 x 390

**Colli 2/2**

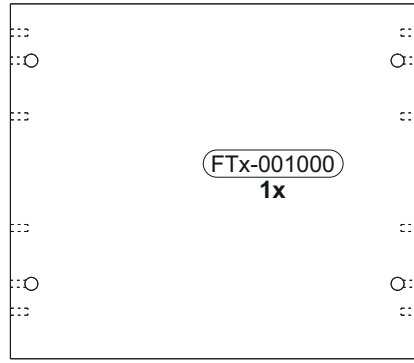

468 x 407

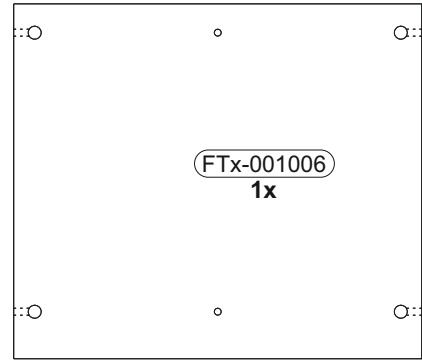

468 x 407

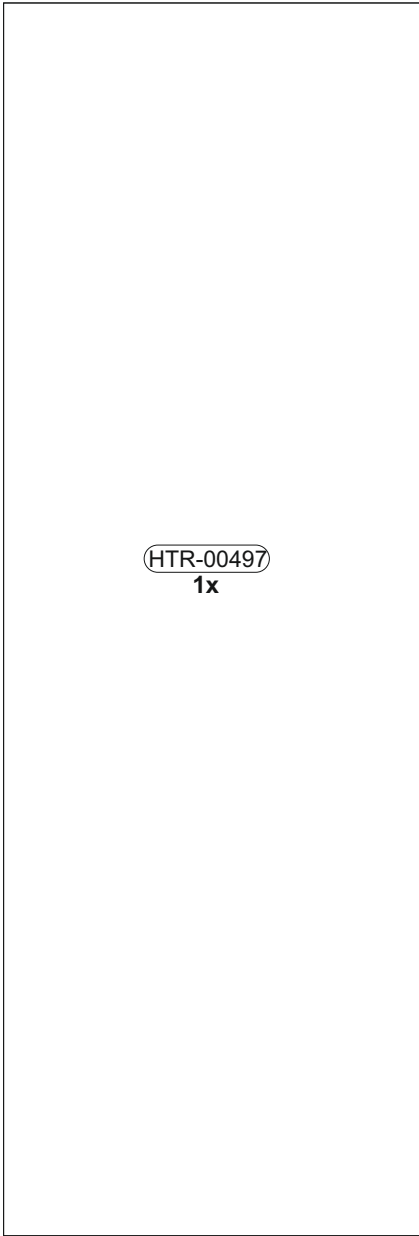

1414 x 480

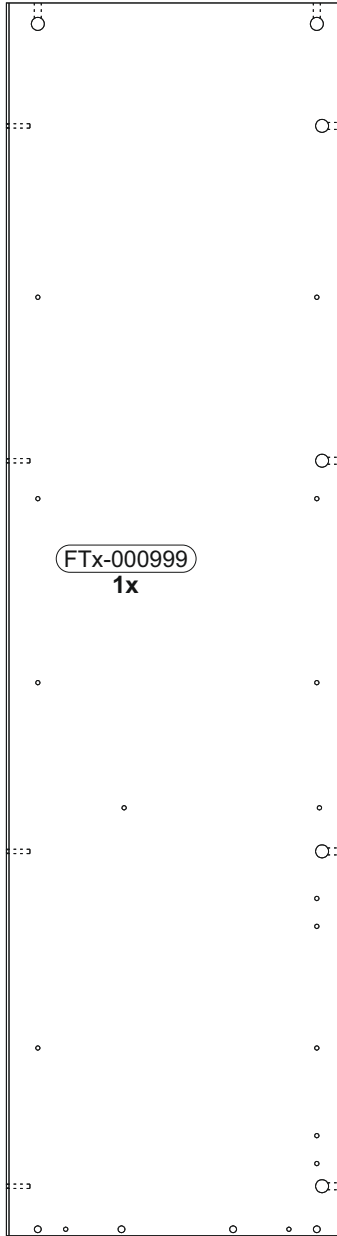

1414 x 386

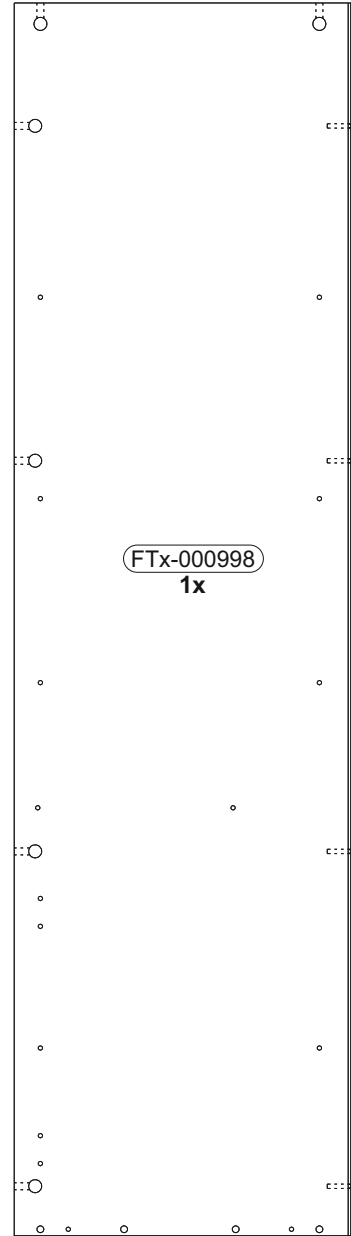

1414 x 386

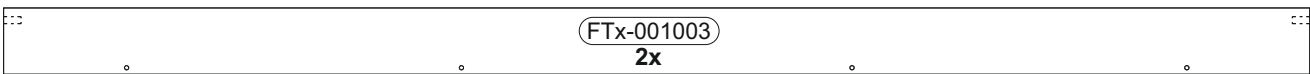

1498 x 76

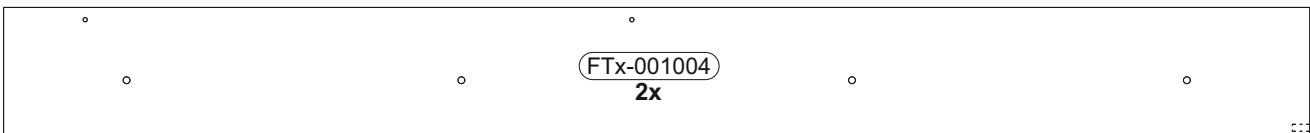

1498 x 152

**1**

	B02-10		B02-20		B02-103		B05-130	
	12x	ø15x12mm	2x		8x	8x30	1x	Leim

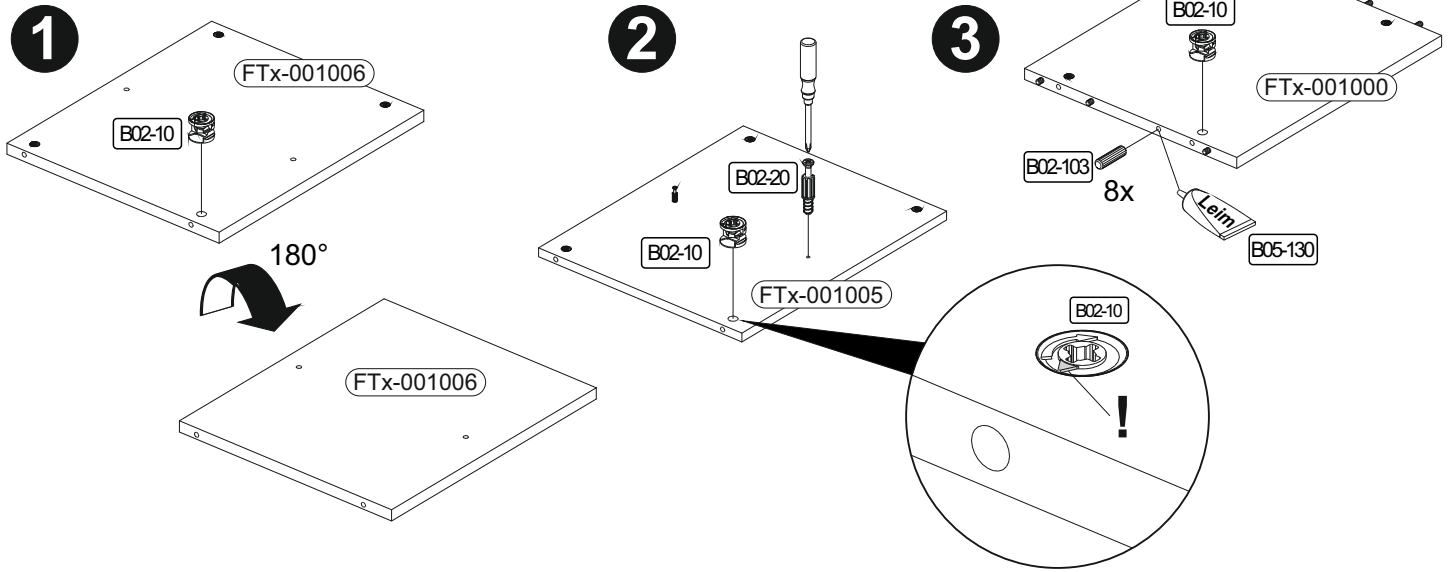

**2**

	B02-10		B02-20		B02-160	
	2x	ø15x12mm	4x		4x	

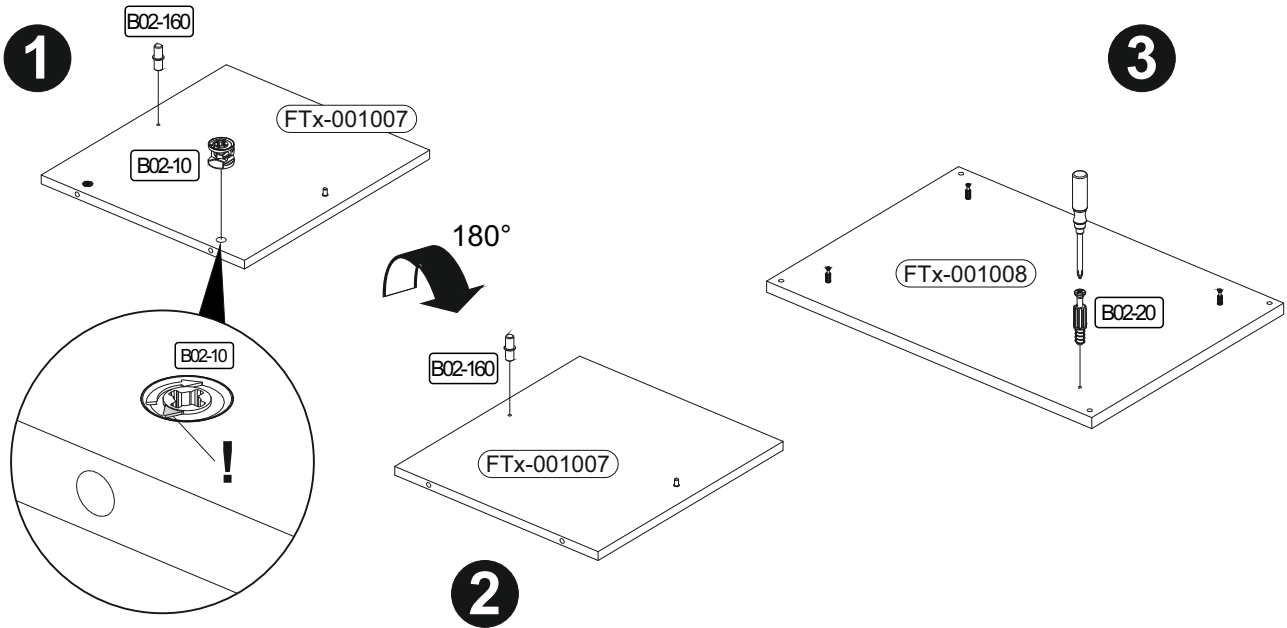

**3**

	B02-20	
	8x	

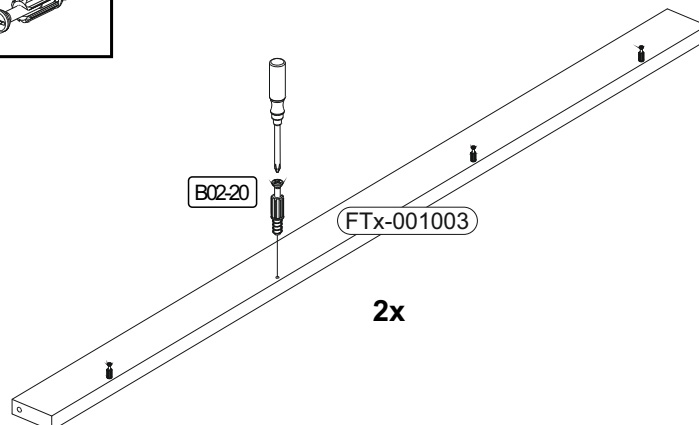

4

	B02-10		B02-20		B02-160		B01-200	
	12x	ø15x12mm	12x		8x		4x	6,3x13

1

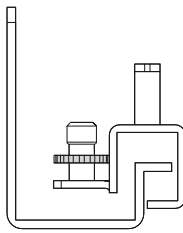
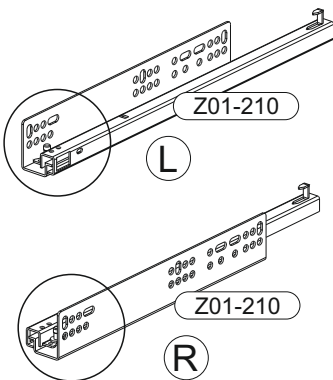

Die Stellräder, die der Höhenverstellung dienen nach ganz unten drehen

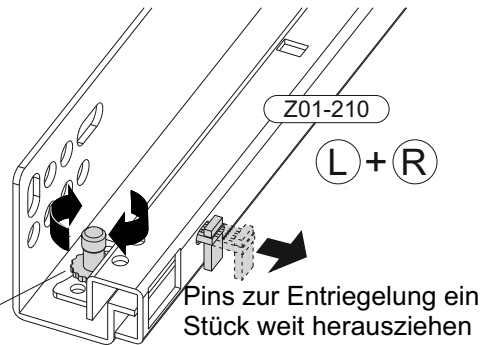
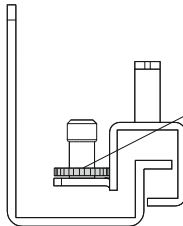

2

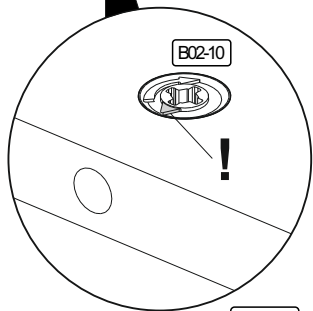
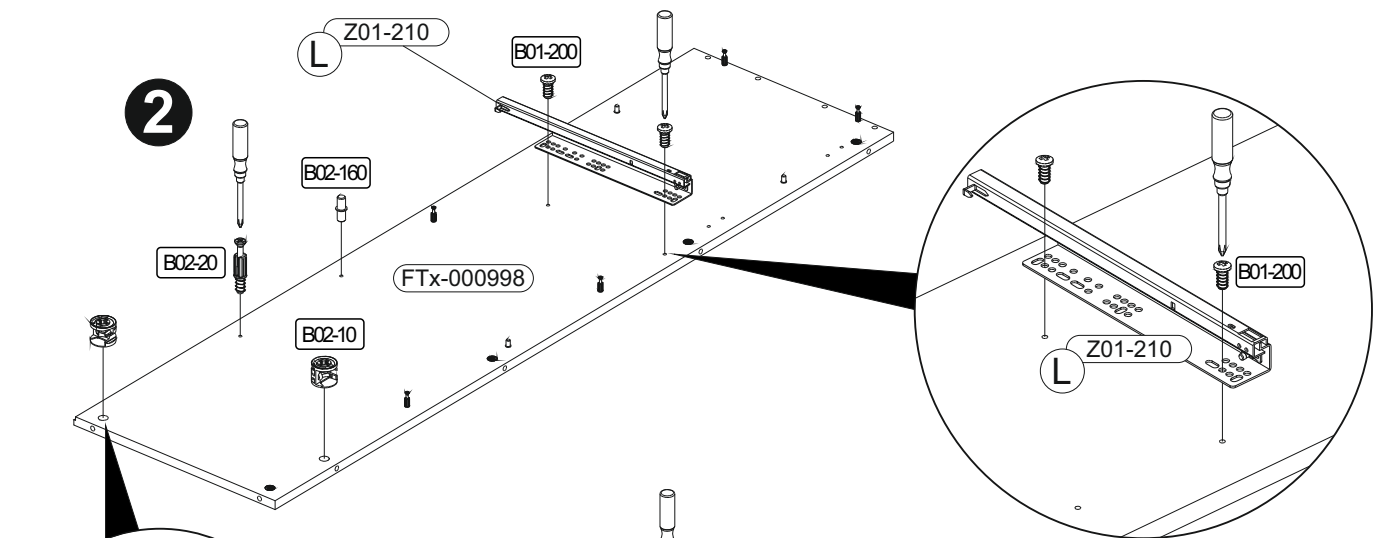

3

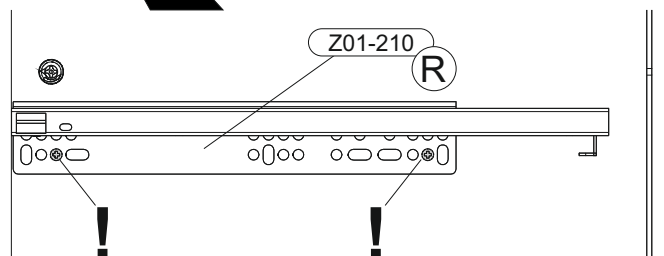
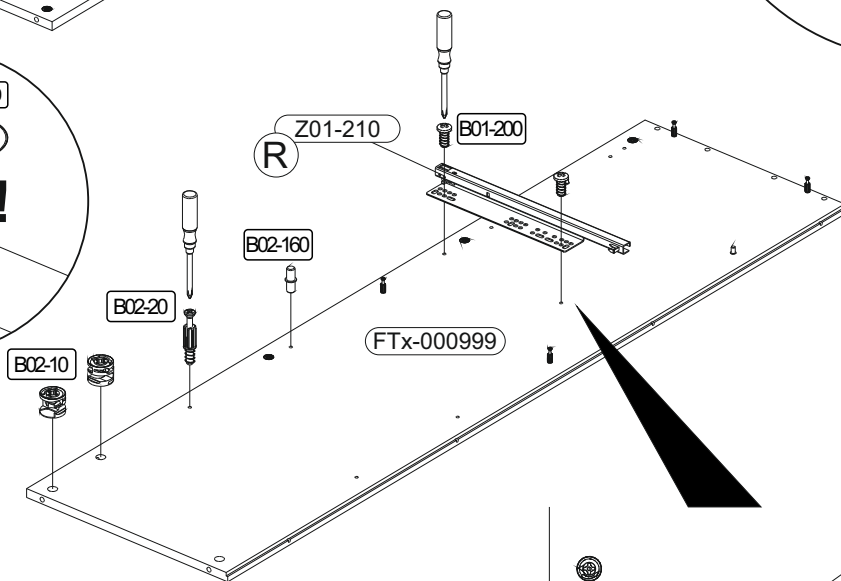

**5**

	<b>B01-329</b> 2x	 M4x22	<b>B01-30</b> 5x	 3x16	<b>B06-440</b> 1x		<b>B02-08</b> 4x	 ø15x10mm	<b>B02-20</b> 4x	
									<b>B01-70</b> 2x	 3x30

**1**

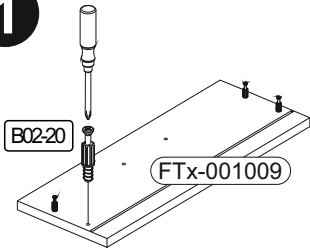

**2**

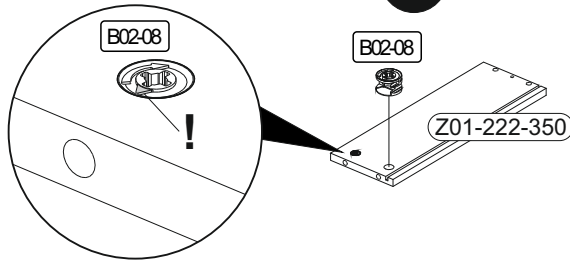

**3**

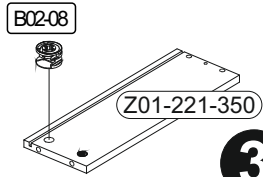

**4**

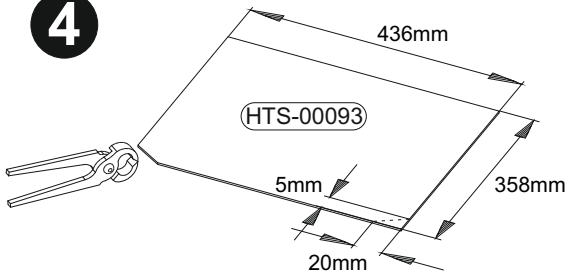

**5**

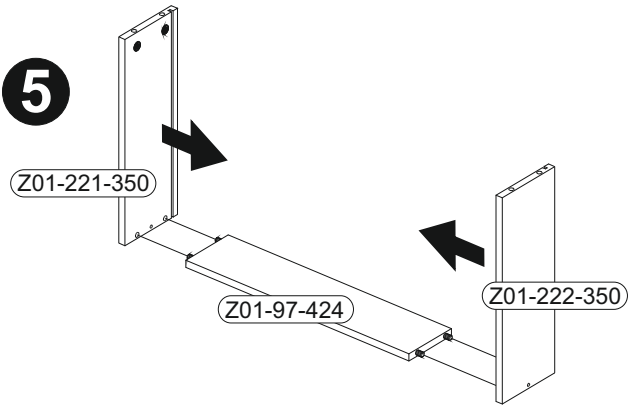

**6**

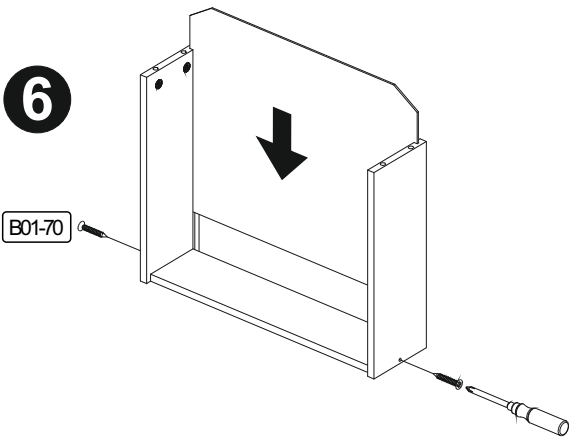

**7**

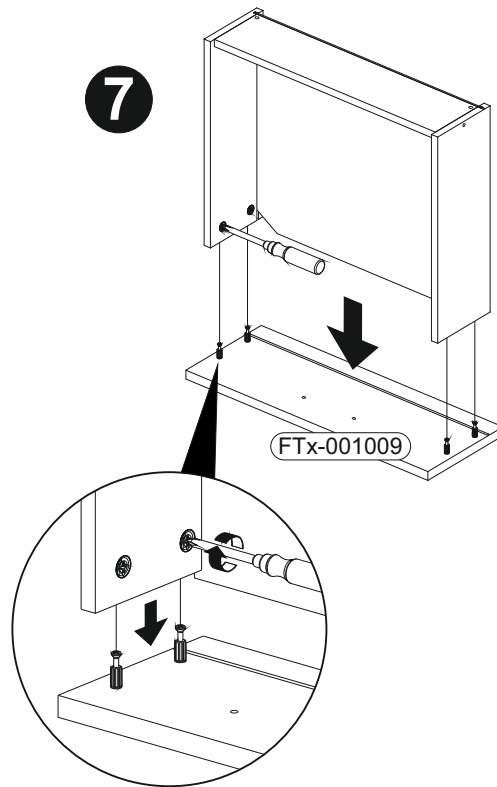

**8**

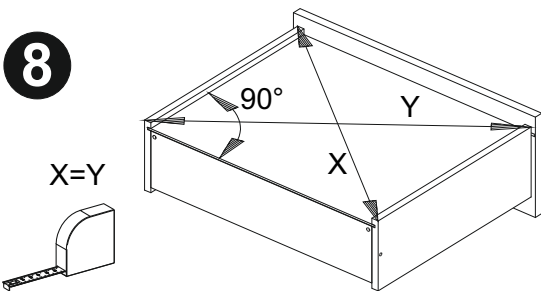

**9**

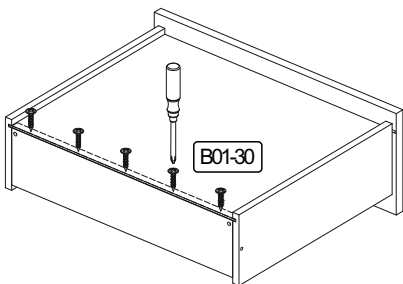

**10**

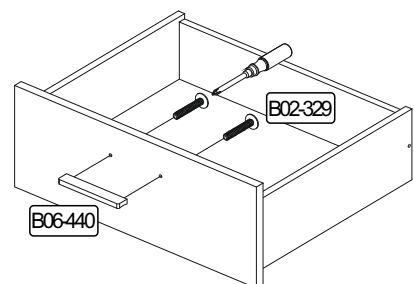

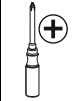
**6** 

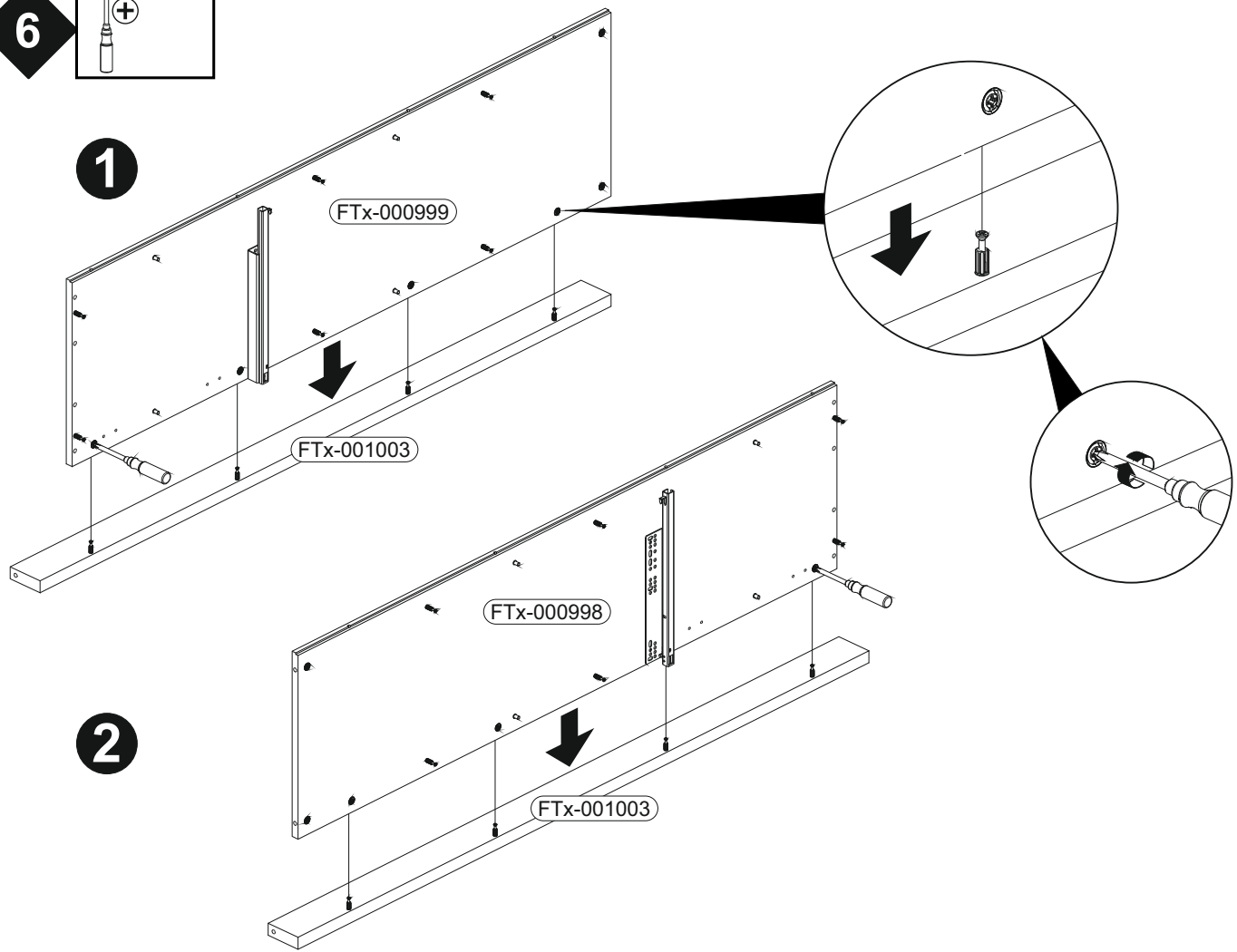

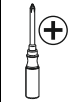

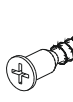

**7** 

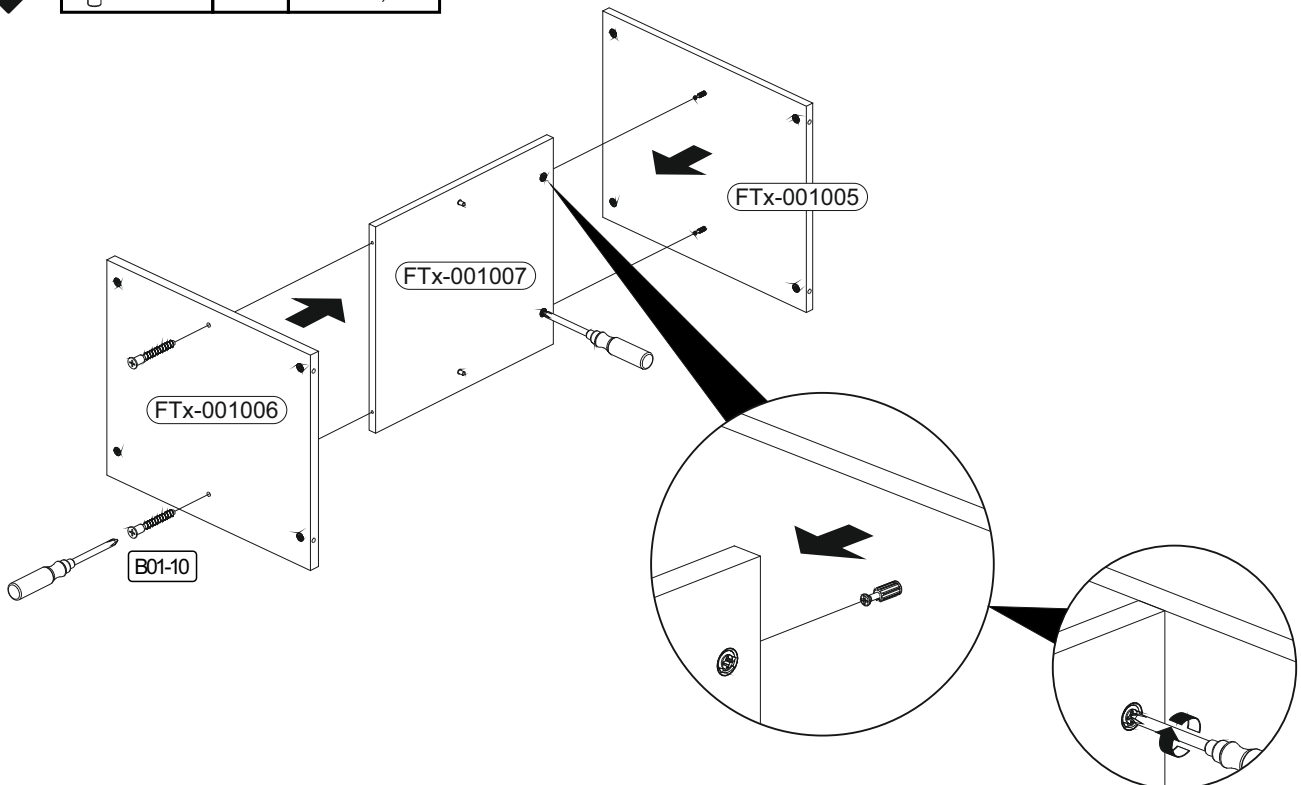
B01-10
2x

 6,3x50



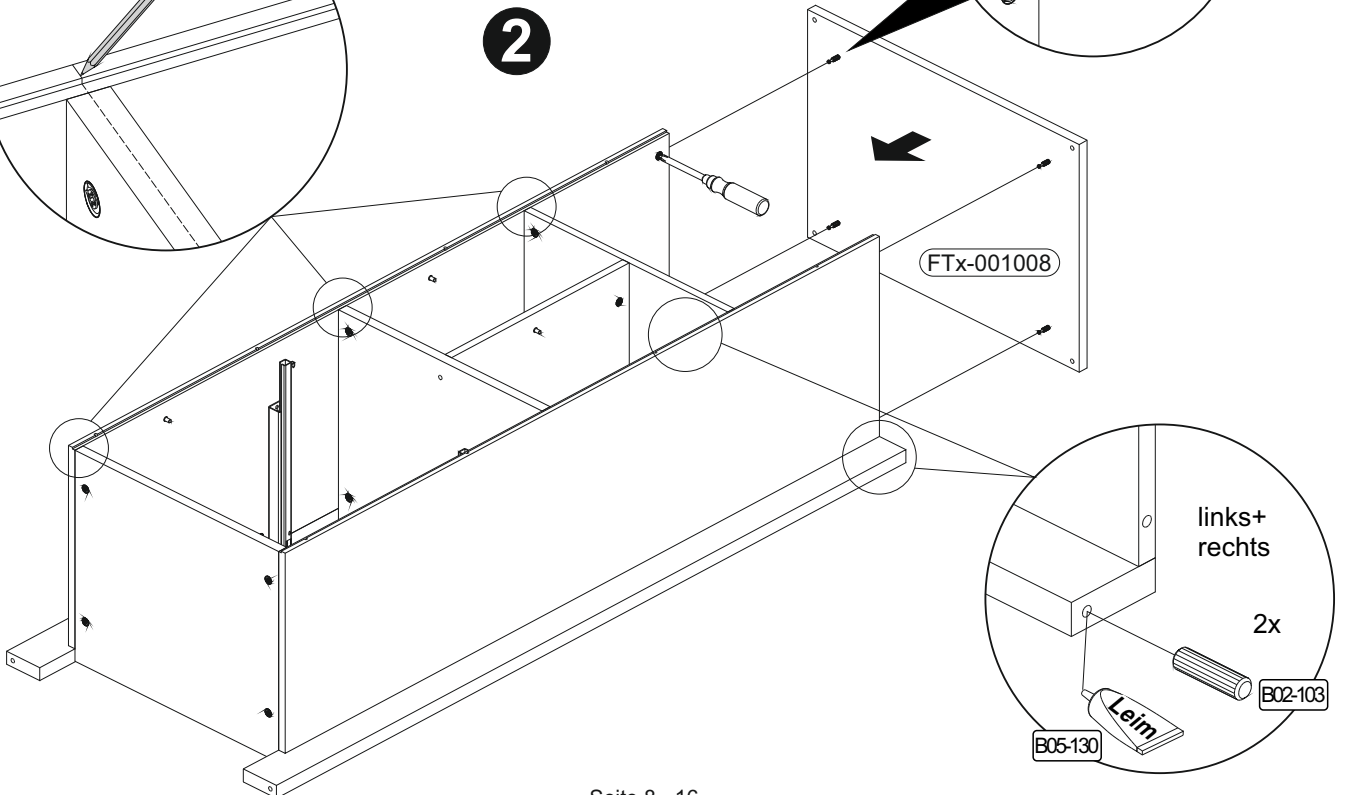
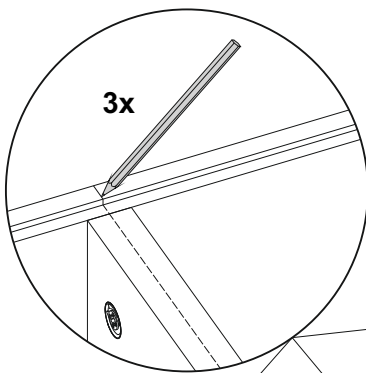
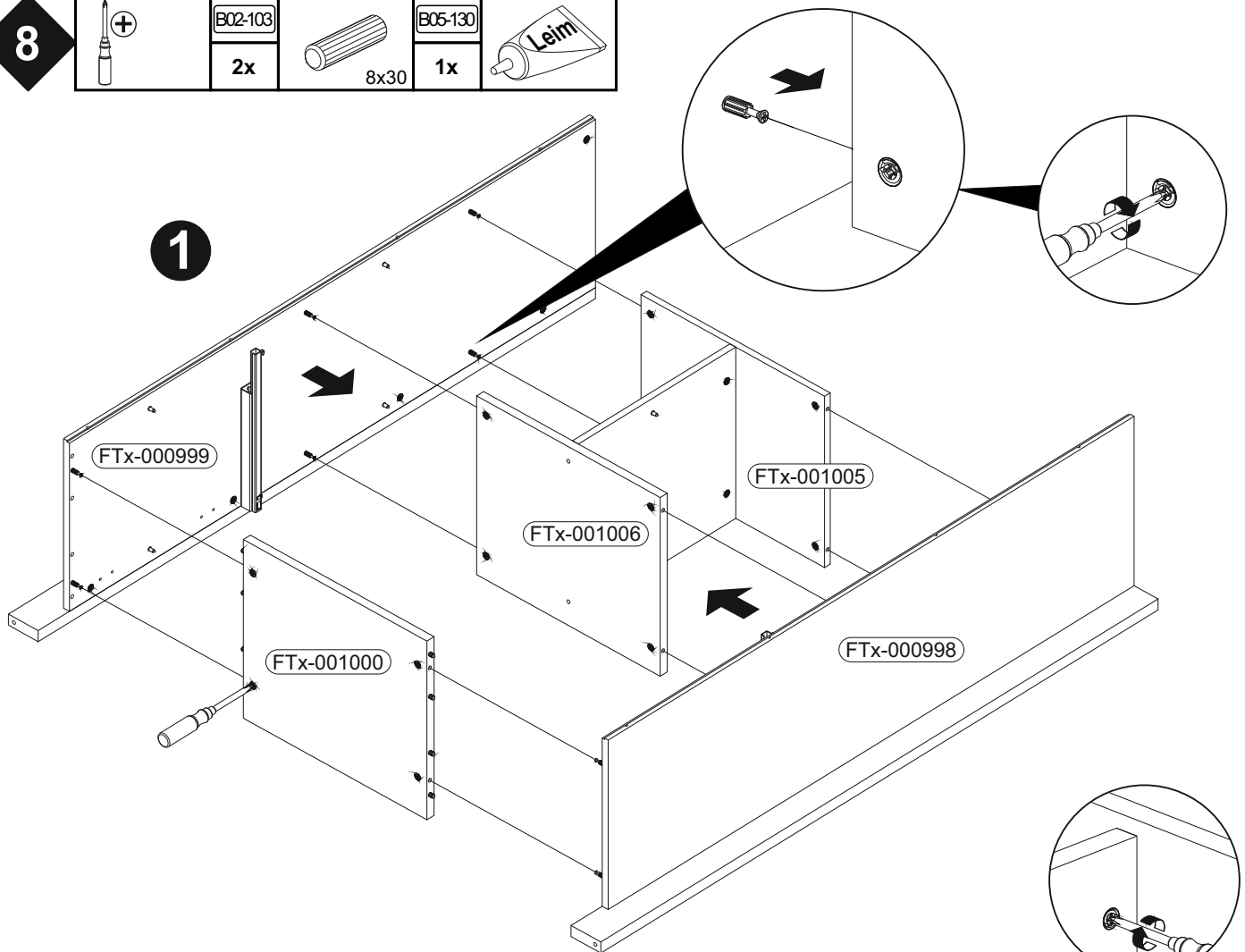

8

				
		2x	8x30 1x	Leim





9

		
B01-30		3x16
16x		

HTR-00497

1

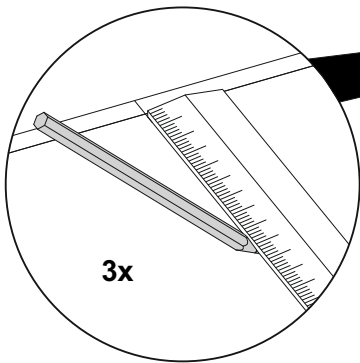
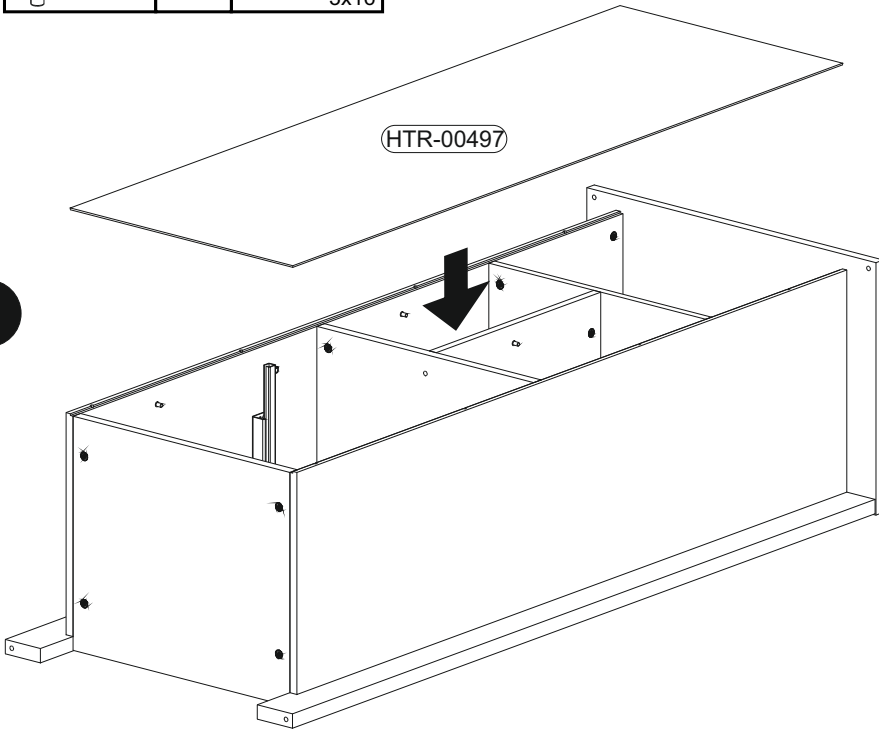

2

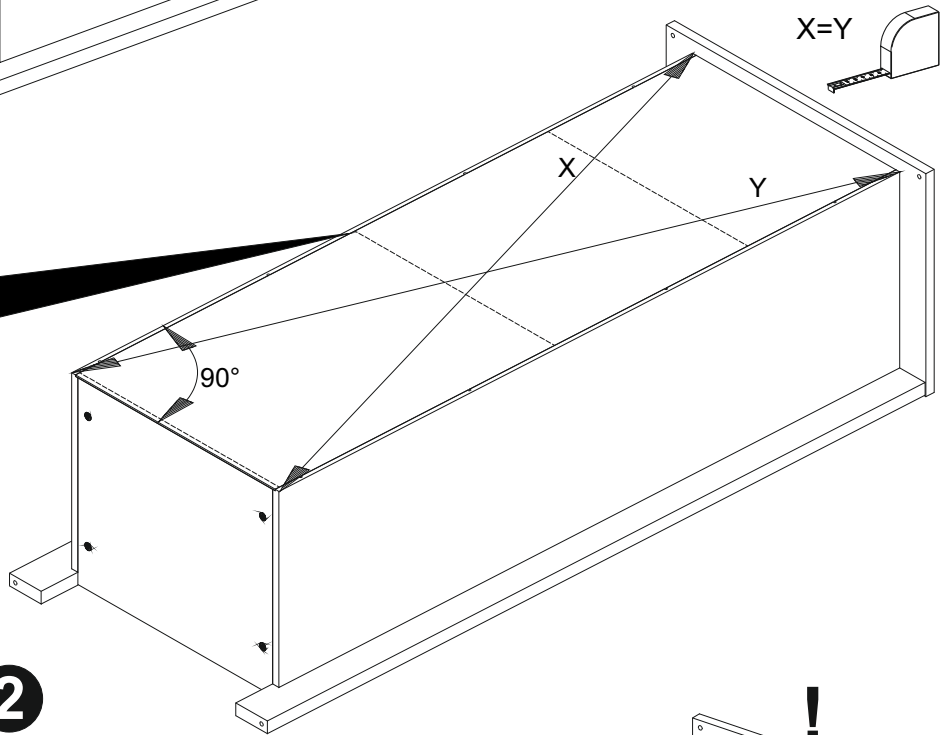

3

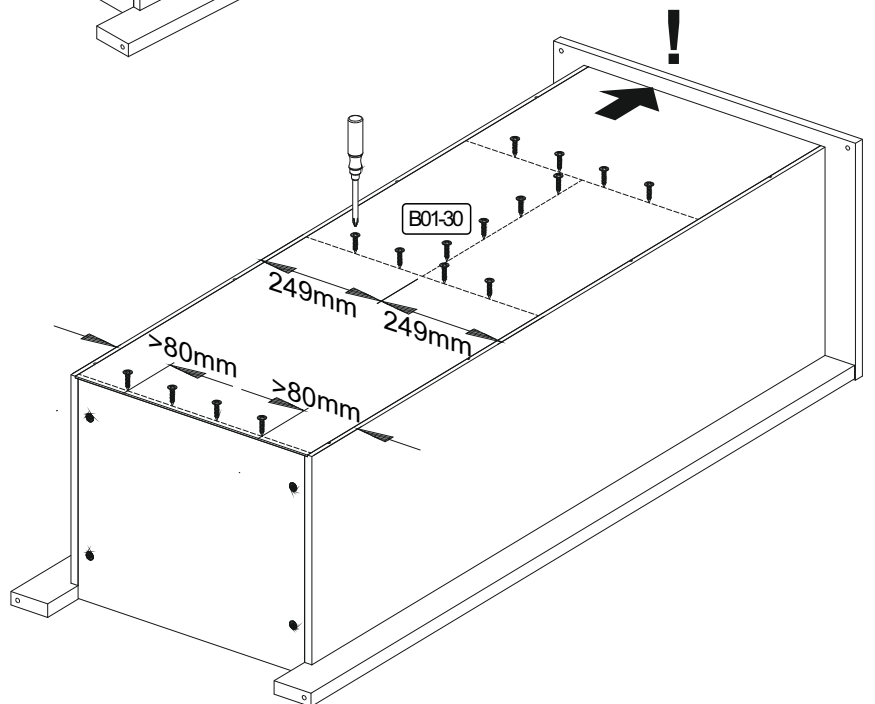

10

	8x	4x	2x	1x	
		6,3x50	4,5x60	8x30	

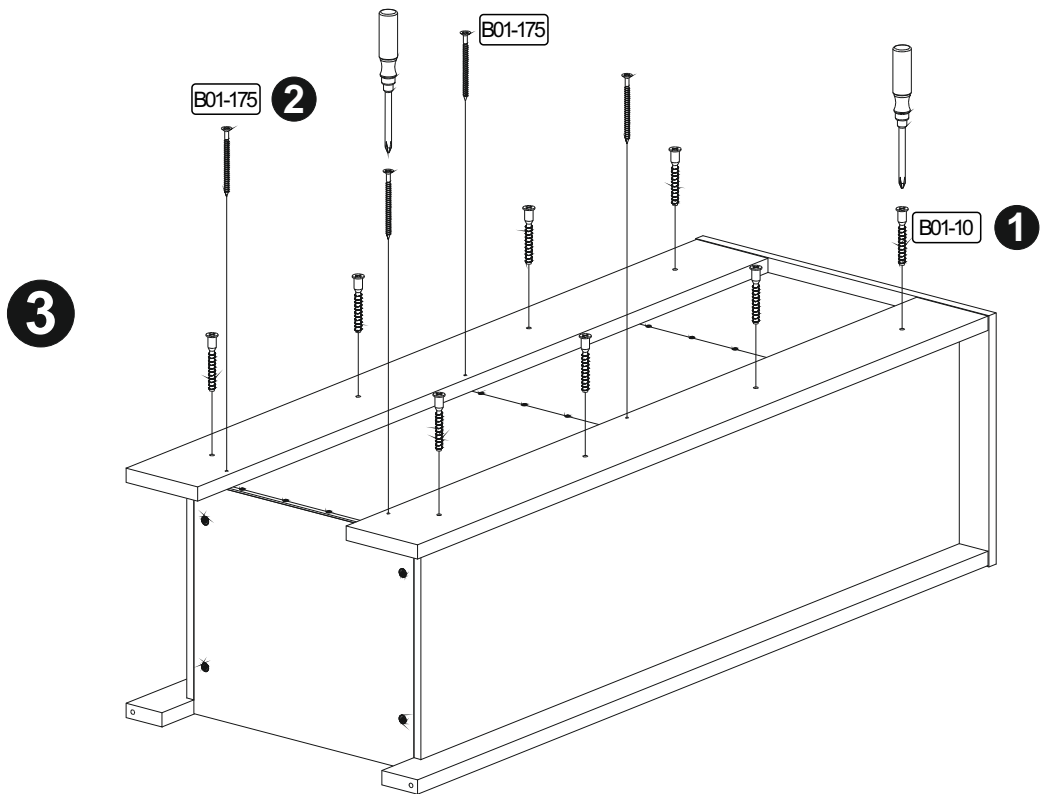
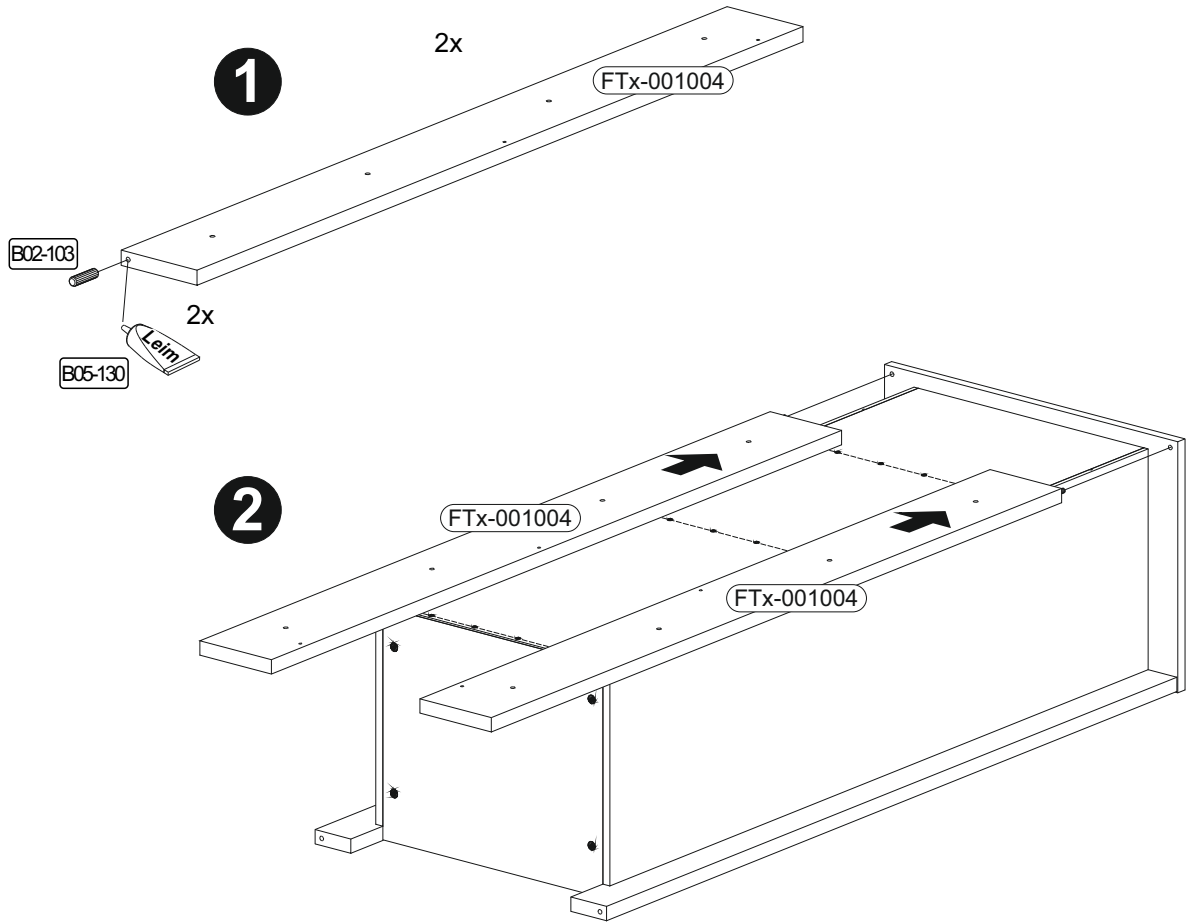

11

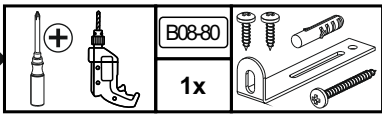

▶ SCAN ME

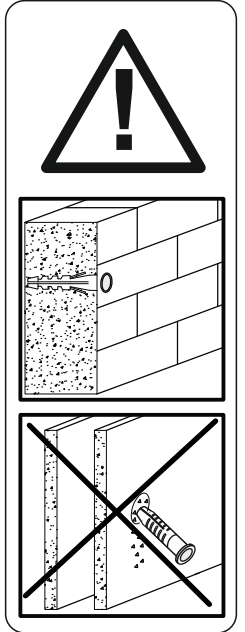
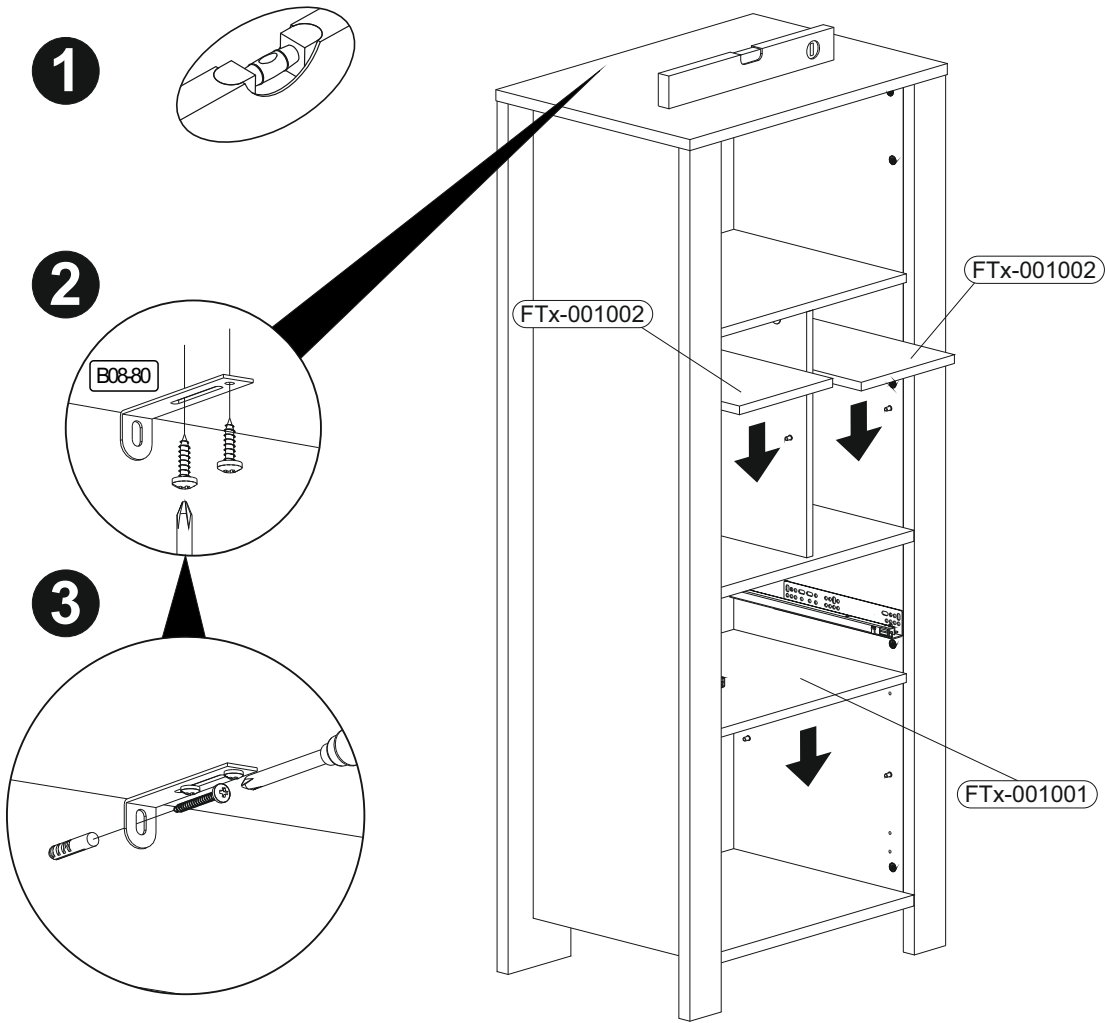

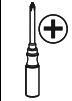

<b>Achtung • Attention • Attenzione • Opgelet • Uwaga • Pozor • Figyelem • Atenție • Dikkat • Внимание</b>	
(D)	Wandbefestigung dient als Kippschutz - unbedingt anbringen! Bei einigen Wandtypen kann ein Spezialdübel erforderlich sein!
(GB)	The wall fastening serves to prevent tipping - be absolutely sure to mount it! For certain wall types, a special wall plug may be necessary!
(FR)	La fixation murale sert de protection contre le basculement – à installer impérativement ! Pour certains types de murs il faut des chevilles spéciales !
(TR)	Duvardaki sabitleme, devrilmeye karşı bir emniyet tedbiridir ve mutlaka monte edilmelidir! Bazı duvar tiplerinde bunun için özel bir dübel gerekli olabilir!
(IT)	Il fissaggio alla parete serve da protezione anti-ribaltamento – attaccarla assolutamente! Per alcune strutture di parete può essere necessario un tassello speciale!
(NL)	Bevestiging aan de muur dient als kantelbescherming – zeker en vast bevestigen! Bij enkele muurtypes is een speciale plug misschien vereist!
(RU)	Обязательно установите крепление на стене во избежание опрокидывания! Для некоторых типов стен может потребоваться специальный дюбель!
(CZ)	Montáž na stěnu slouží jako ochrana proti převrnutí – bezpodmínečně umístěte! U některých typů stěn může být zapotřebí speciální hmoždinka!
(HU)	A termék a falhoz kel rögzíténi, különben az felborulhat! Egyes faltípusoknál speciális tiplít kell használni!
(RO)	Sistemul de fixare la perete servește ca protecție la răsturnare - de montat obligatoriu! Pentru unele tipuri de pereți este posibil să fie necesar un diblu special!
(PL)	Mocowanie do ściany jest jednocześnie zabezpieczeniem przed przewróceniem – koniecznie zamontować! Do niektórych rodzajów ścian konieczne zastosować specjalne kołki mocujące.
(SK)	Upevnenie na stenu slúži ako ochrana proti prevráteniu – bezpodmienečne použite! Pre niektoré druhy stien môže byť potrebná špeciálna hmoždinka!

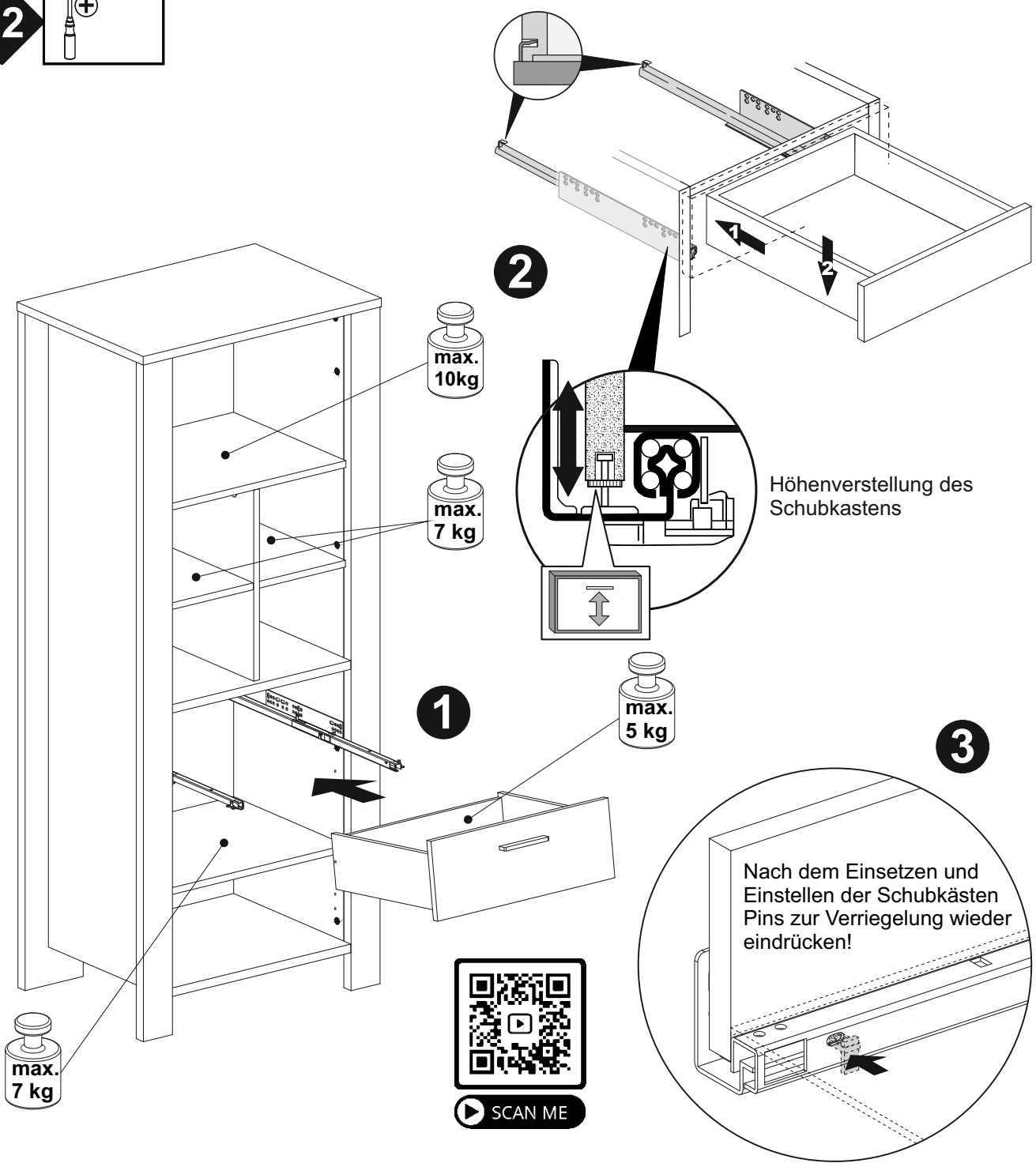
**12** 

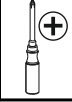

**13** 

B03-43		B01-80	
2x		4x	3,5x13

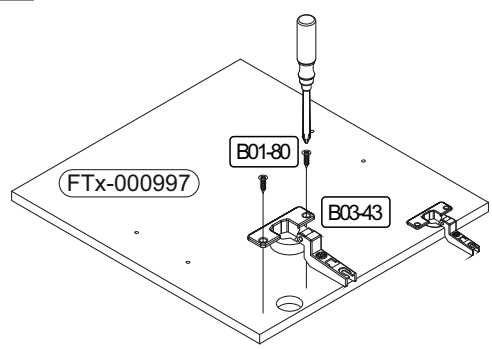

14

	B03-11		B01-37		B06-440		
	2x		1x	4,5x25	1x	2x	M4x22

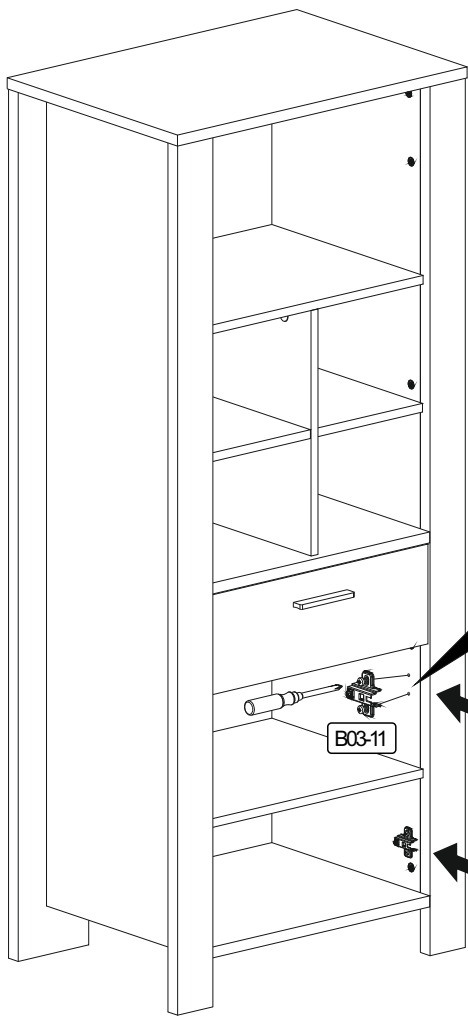

1

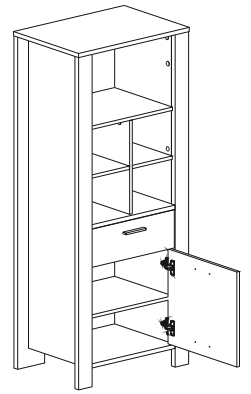
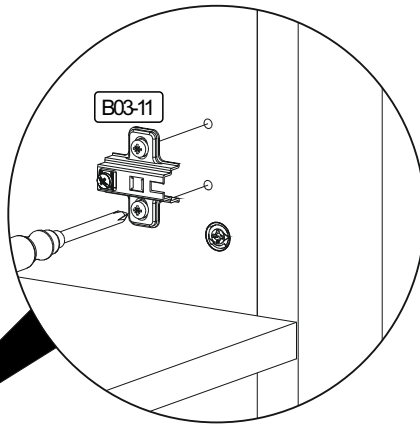

R

2

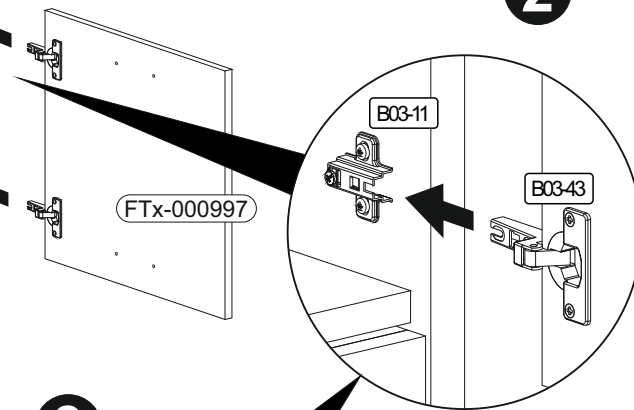

3

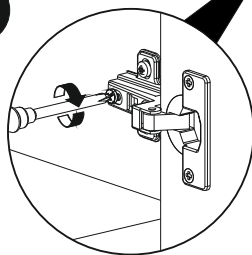

4

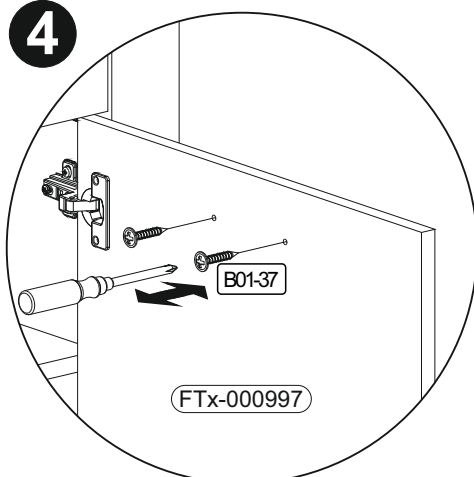

SCAN ME

5

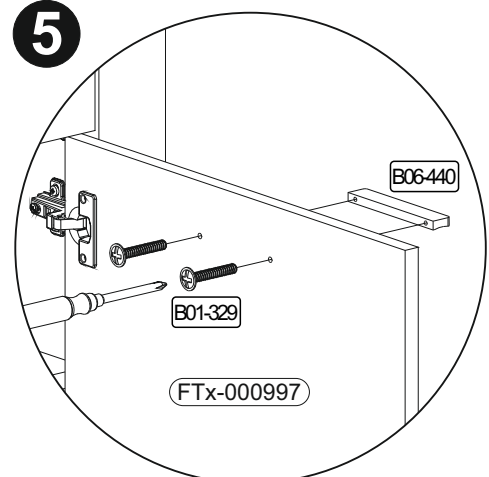

15

	B03-07		B05-02		B05-02 K1002	
	1x		8x	ø20mm	2x	ø20mm

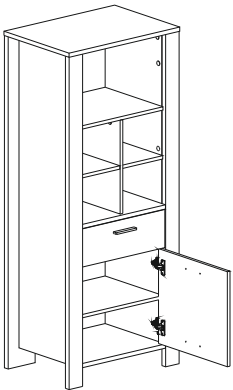

R

### Montage der Türdämpfung

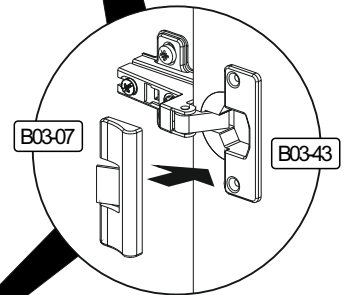
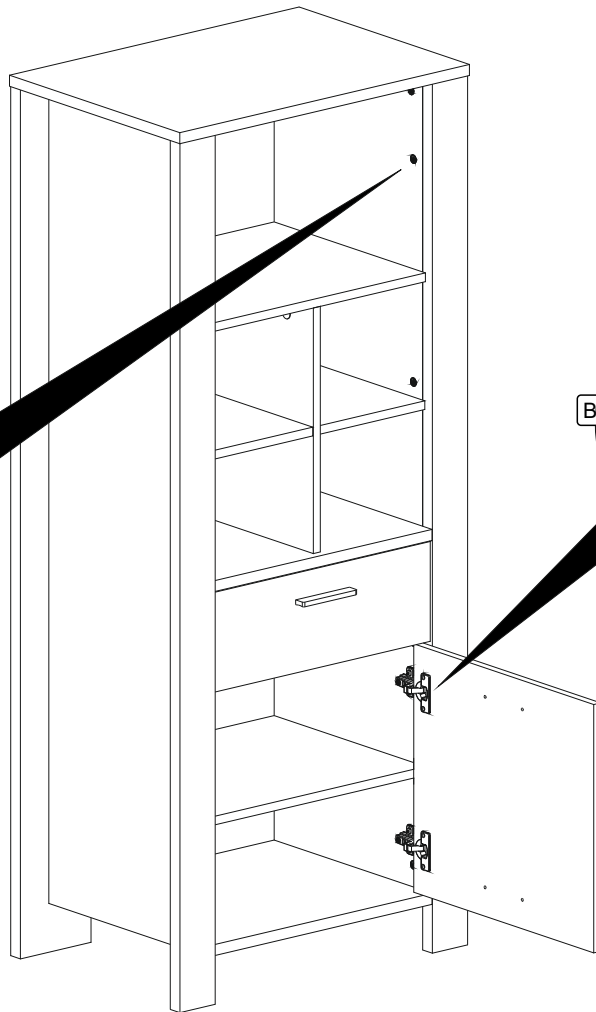
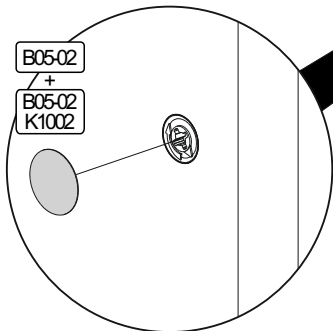
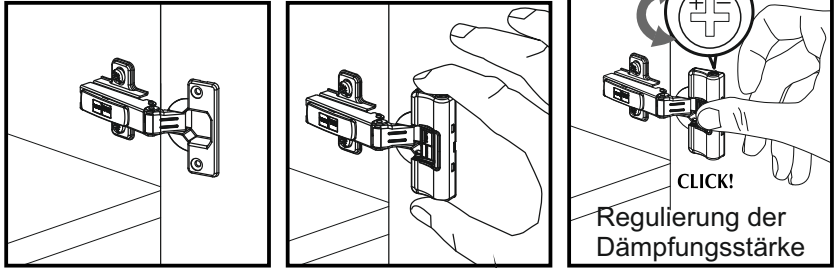

### Einstellung der Türen



SCAN ME

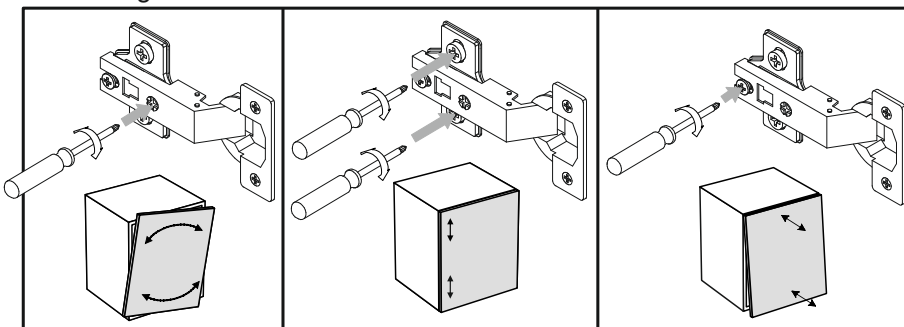

14

	B03-11		B01-37		B06-440		
	2x		1x	4,5x25	1x	2x	M4x22

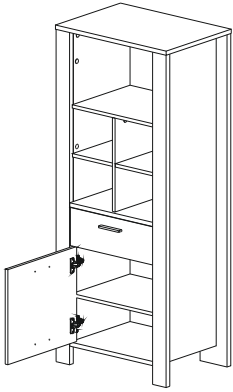

L

1

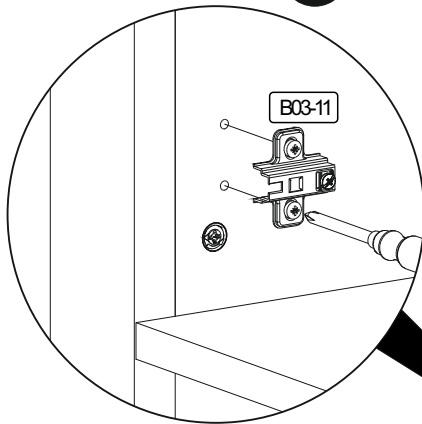

2

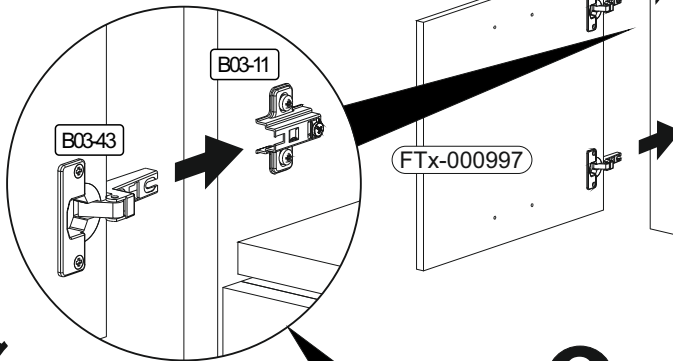

3

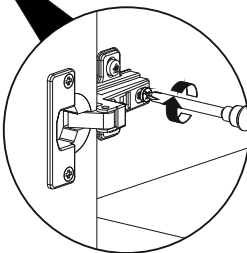

4

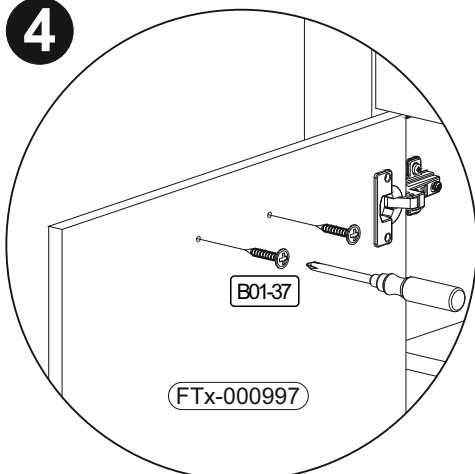

5

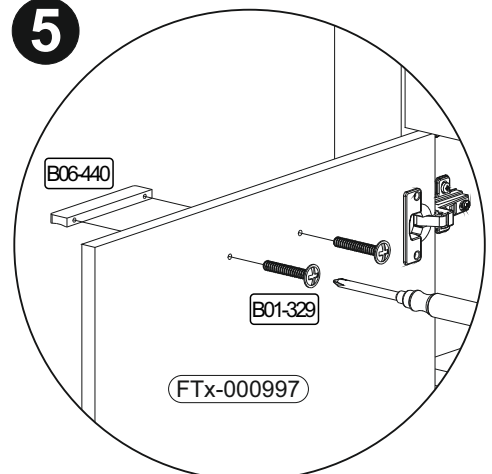

▶ SCAN ME

15

	1x	8x	ø20mm	2x	ø20mm

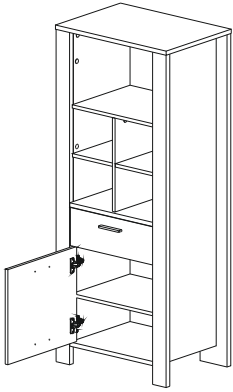

L

### Montage der Türdämpfung

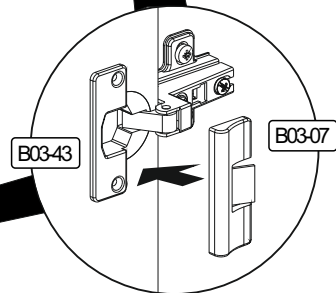
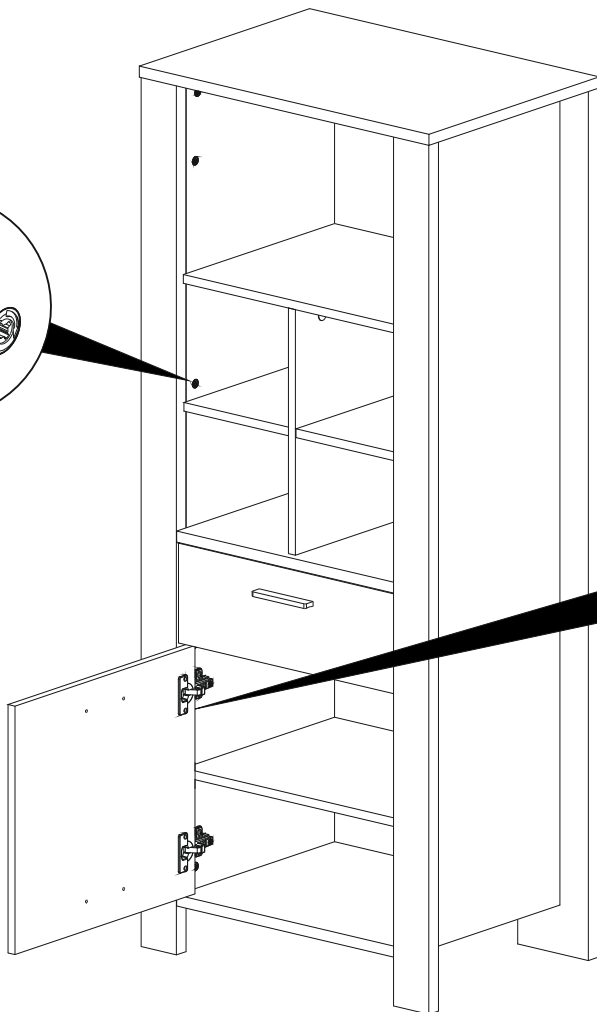
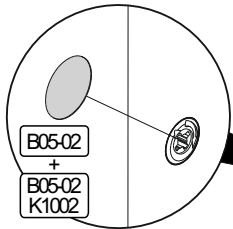
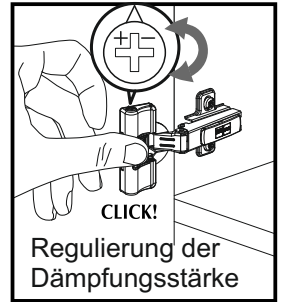
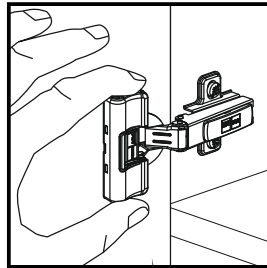
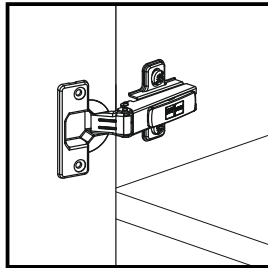

### Einstellung der Türen



▶ SCAN ME

