

Art. Nr.	Kasten Nr. Colli Nr. Colli Nr. Коробка Hom. Polu Nr. Kutusu Nr. Kolonka Č. Počet balení Colli Nr. Nu pachete Colli száma. Colli Nr. Kastes Nr.	Art. Nr.	Kasten Nr. Colli Nr. Colli Nr. Коробка Hom. Polu Nr. Kutusu Nr. Kolonka Č. Počet balení Colli Nr. Nu pachete Colli száma. Colli Nr. Kastes Nr.	Art. Nr.	Kasten Nr. Colli Nr. Colli Nr. Коробка Hom. Polu Nr. Kutusu Nr. Kolonka Č. Počet balení Colli Nr. Nu pachete Colli száma. Colli Nr. Kastes Nr.	Art. Nr.	Kasten Nr. Colli Nr. Colli Nr. Коробка Hom. Polu Nr. Kutusu Nr. Kolonka Č. Počet balení Colli Nr. Nu pachete Colli száma. Colli Nr. Kastes Nr.
50045024	1 / 10	76369366	1 / 1	69642036	1 / 10	29655267	1 / 1
	2 / 10	76400952	1 / 1		2 / 10	65772416	1 / 1
	3 / 10	44492021	1 / 1		3 / 10	63557367	1 / 1
	4 / 10	70512937	1 / 1		4 / 10	24197526	1 / 1
	5 / 10	82723532	1 / 1		5 / 10	63297664	1 / 1
	6 / 10	44727303	1 / 2		6 / 10	52009719	1 / 2
	7 / 10		2 / 2		7 / 10		2 / 2
	8 / 10	75855429	1 / 2		8 / 10	50321914	1 / 2
	9 / 10		2 / 2		9 / 10		2 / 2
	10 / 10		48739164		1 / 1		10 / 10

idpOSBY8-1 idpOSBY8-2

Art. 76369366 29655267

LKZ 75007

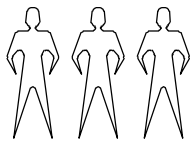

≈2h

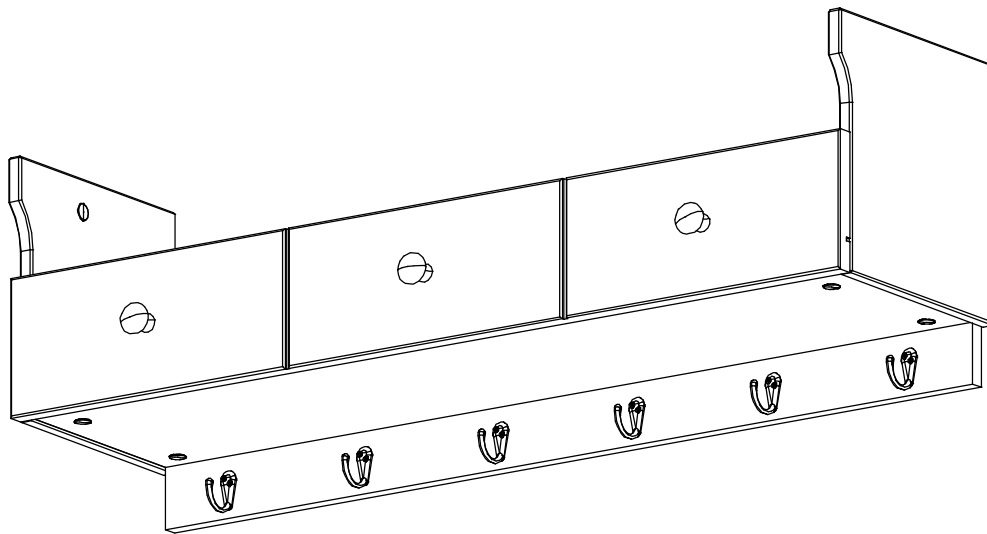
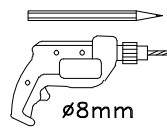
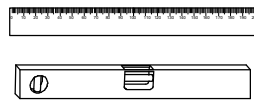
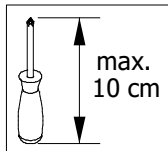
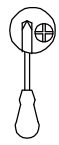





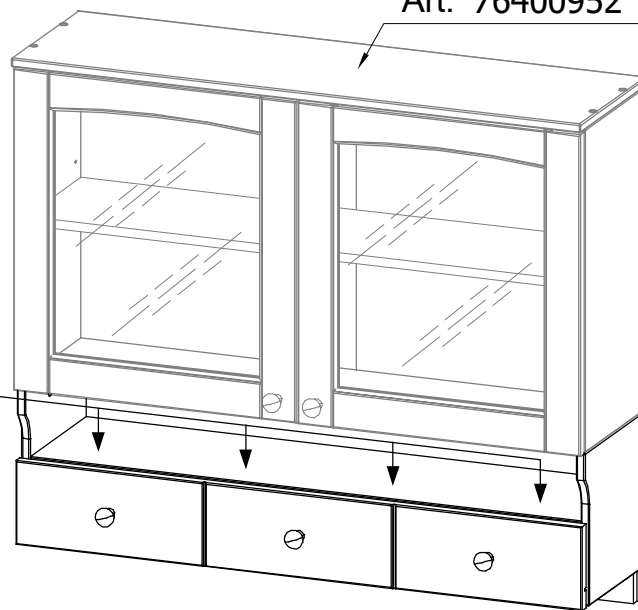



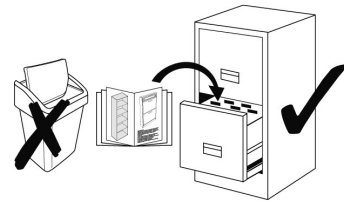
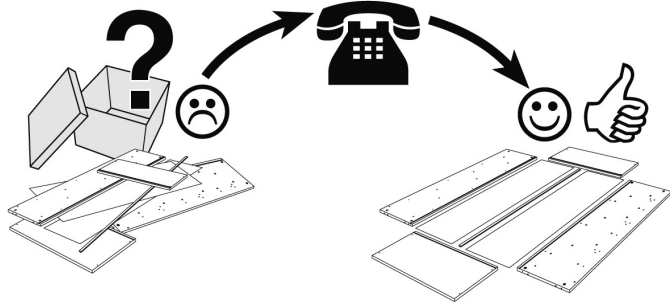



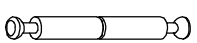
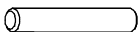

Art. 76400952 65772416

Max. 8 kg



idp12458-1 idp12458-2

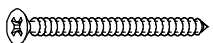

Service • Assistenza • Dienstverlening • Serwis Servis • Szerviz • Сервисная служба	
Name • Nom • Nome • Naam Nazwa • Jméno • Názov • Név Denumire • Isim • Название	
Nr • No • N • Номер • Č • Sz	
Tur • Туре • Тір • Тірус • Тіро Тип	
	
	

				H1		x10 ø 8x30
D2	 x16 ø 5/11x34	D59	 x2 L=34/34	H3		x4 Ø8x50
D317	 x20 ø 15x12	B122	 x3	A16		x3 M4x25
D4	 x16 ø 17	L50	 x6	A121		x12 meln. ø 3x15
E4	 x1 17x182mm	A15	 x4 ø 5,8x11	A8		x2 M4x12
N3	 x2 Ø7x1,5	H20	 x2 ø 8x50	A133		x2 ø 4,5x60

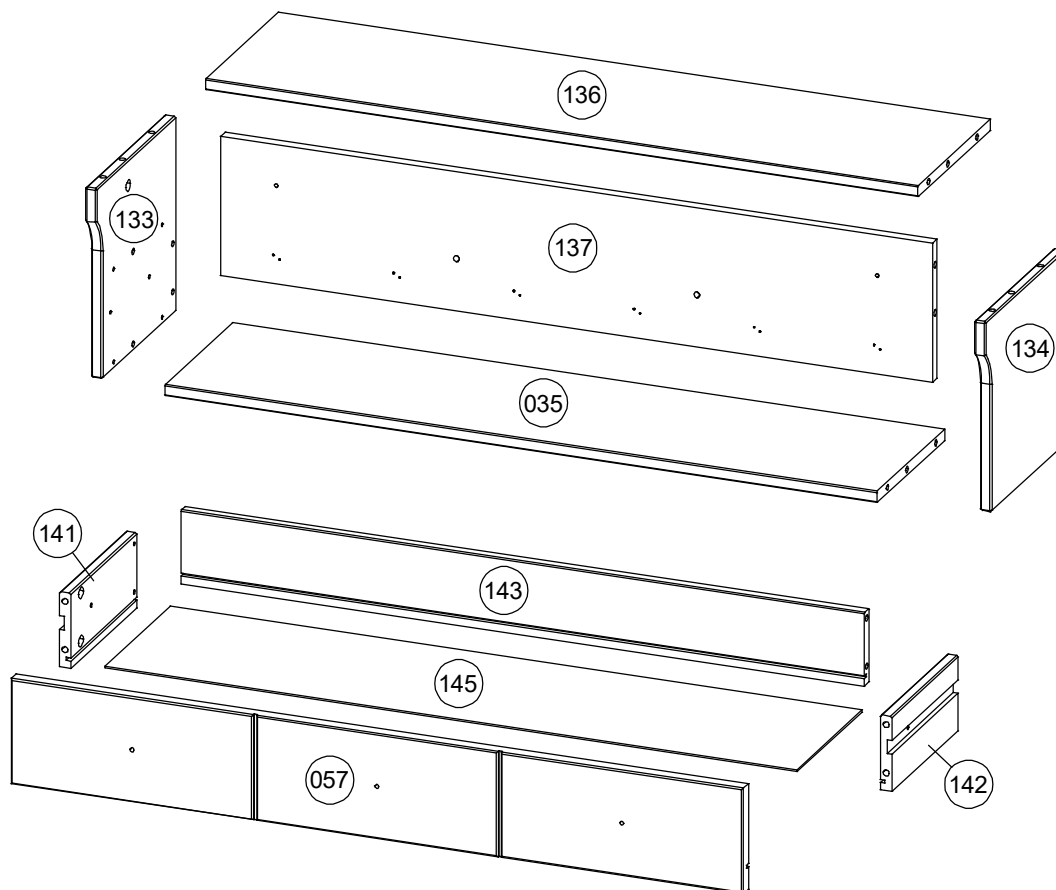



Teil Nr. Pièces Nr. Pieces Nr. Часть Ном. Kawalek Nr. Parça No Kusů Nr. Kusov Nr. Pezzi Nr. Nr piese. Darab száma. Stukken Nr. Kārtas Nr.	Anzahl Quantité Quantity Количество Ilość Miktar Množství Množstvo Quantità Cantitatea Mennyiség Hoeveelheid Skaitis	Kasten Nr. Colli Nr. Colli Nr. Коробка Ном. Polu Nr. Kutusu Nr. Kolonka Č. Počet balení Colli Nr. Nu pachete Colli száma. Colli Nr. Kastes Nr.	Maß, mm Dimensions, mm Dimensions, mm Размеры, mm Wymiary, mm Boyutlar, mm Rozměry, mm Rozmery, mm Dimensioni, mm Dimensiuni, mm Méterek, mm Afmetingen, mm Izmēri, mm	✓
057	1	1 / 1	975 x 140 x 18	
133	1	1 / 1	260 x 260 x 15	
134	1	1 / 1	260 x 260 x 15	
135	1	1 / 1	948 x 223 x 15	
136	1	1 / 1	948 x 239 x 15	
137	1	1 / 1	948 x 185 x 15	
141	1	1 / 1	218 x 100 x 18	
142	1	1 / 1	218 x 100 x 18	
143	1	1 / 1	910 x 98 x 15	
145	1	1 / 1	921 x 214 x 3	

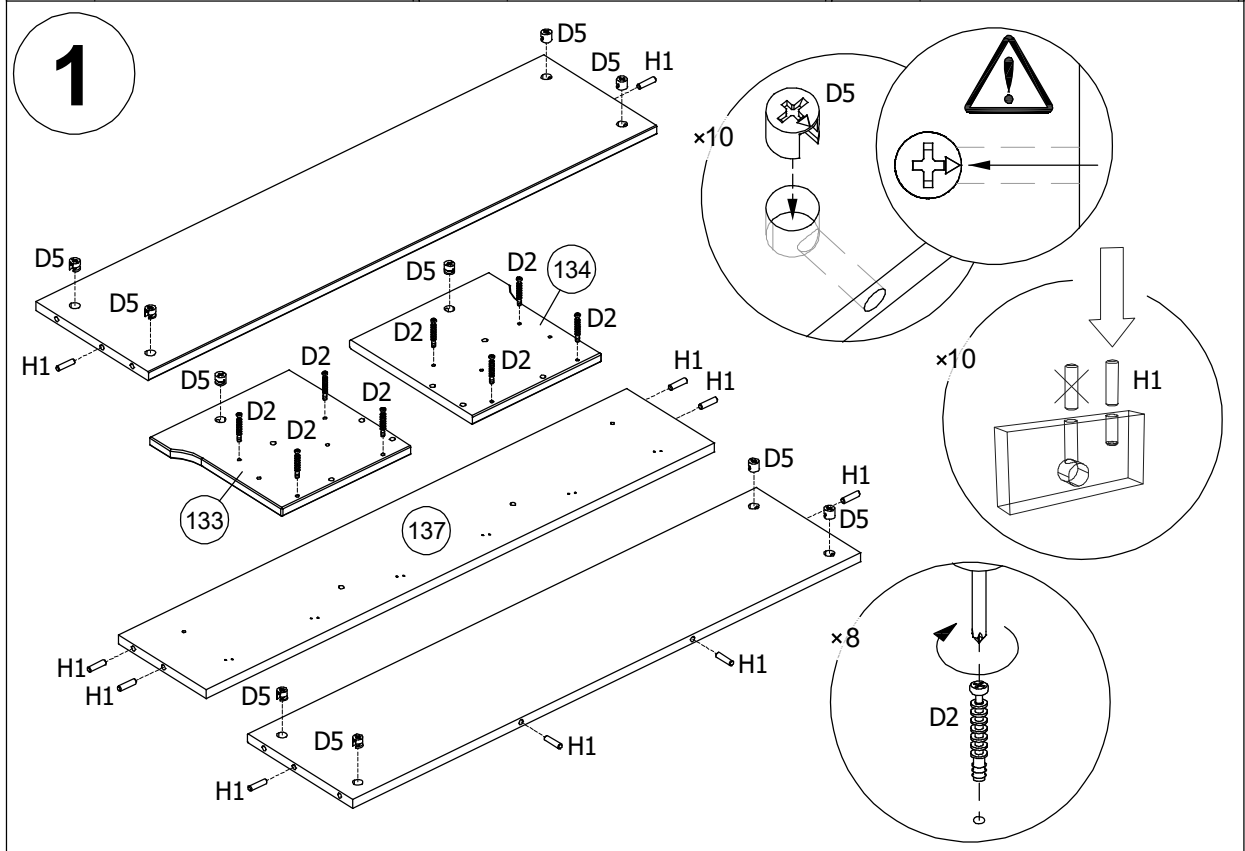

idp12458-1 idp12458-2

H1		x10 ø 8x30	D2		x8 ø 5/11x34	D5		x10 ø 15x12,5
----	---	---------------	----	---	-----------------	----	---	------------------



L50		x6	E4		x1 17x182mm	A15		x4 ø 5,8x11
A121		x12 3x15						

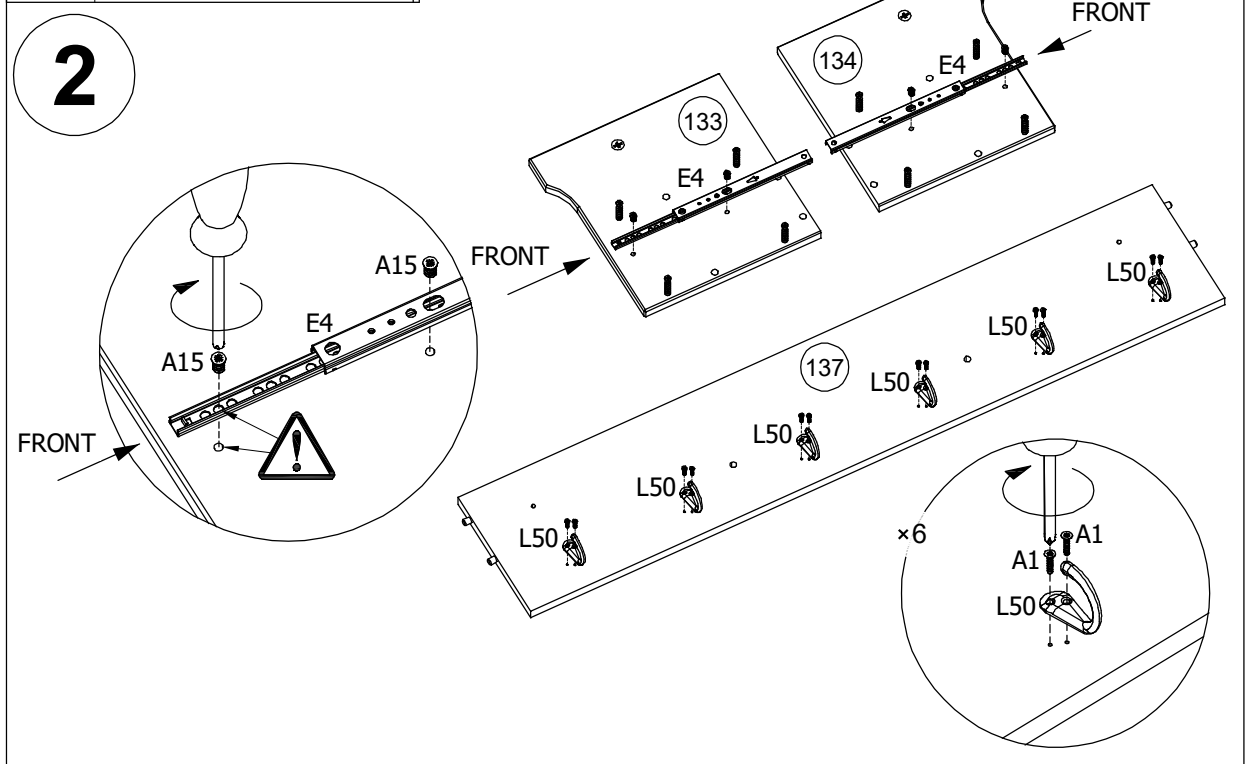

idp12458-1 idp12458-2



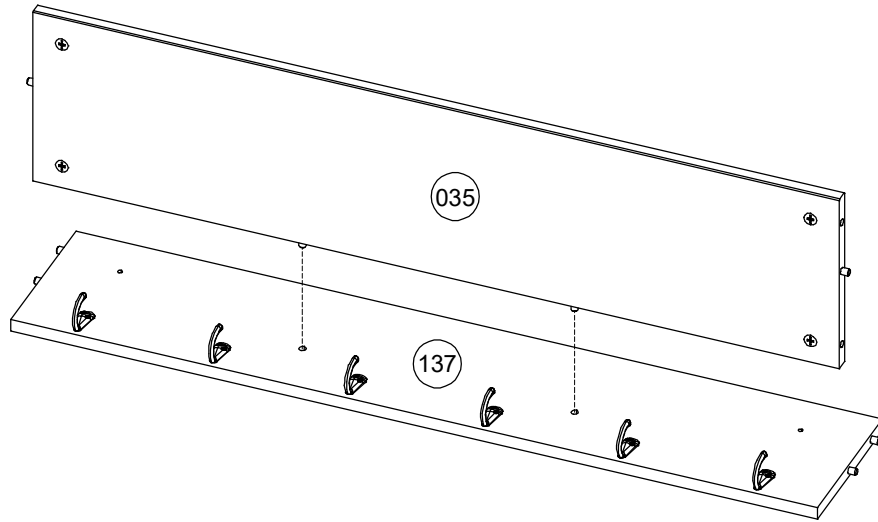

3

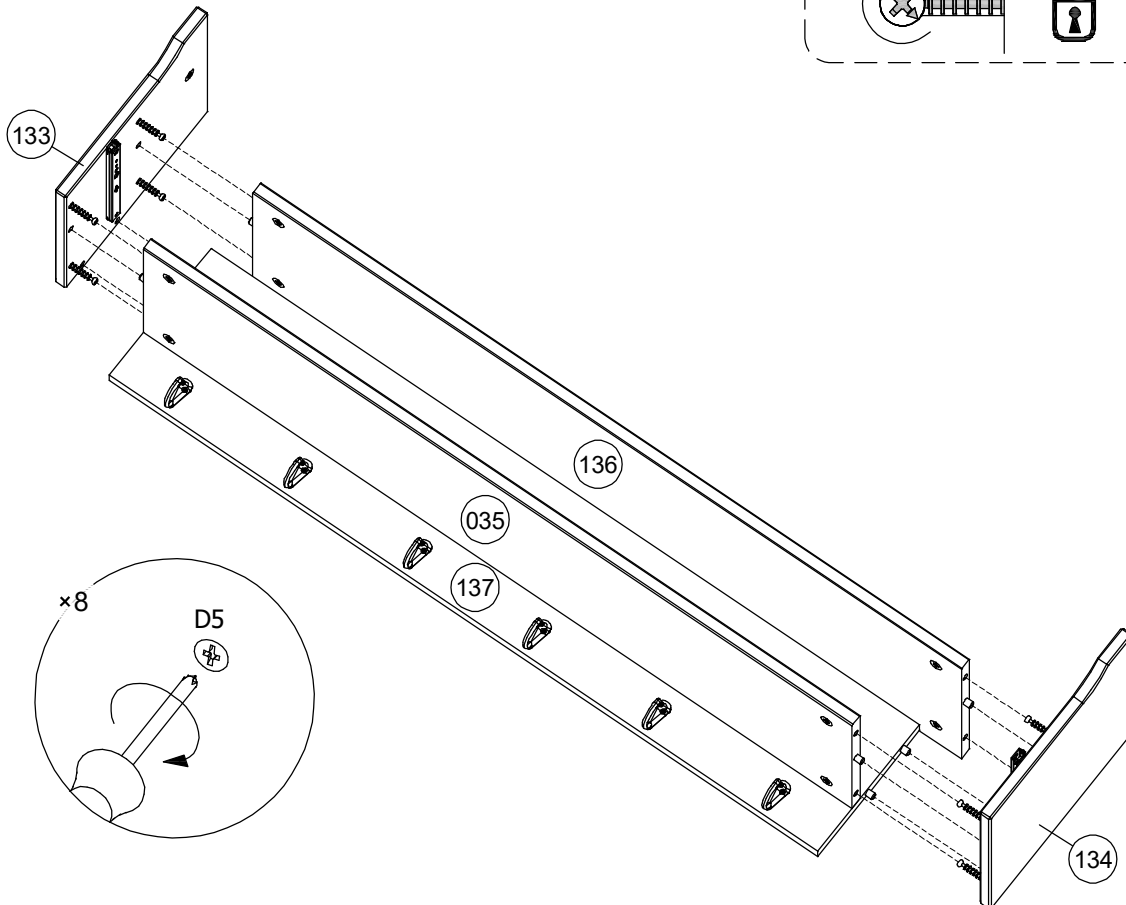
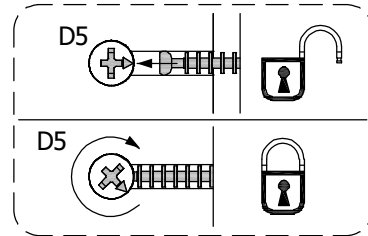
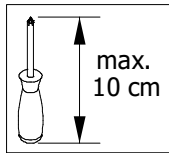

4



idp12458-1 idp12458-2

D317	 x8 ø 15x12	D2	 x8 ø 5/11x34	N3	 x2 Ø7x1,5
B122	 x3	A16	 x3 M4x25		

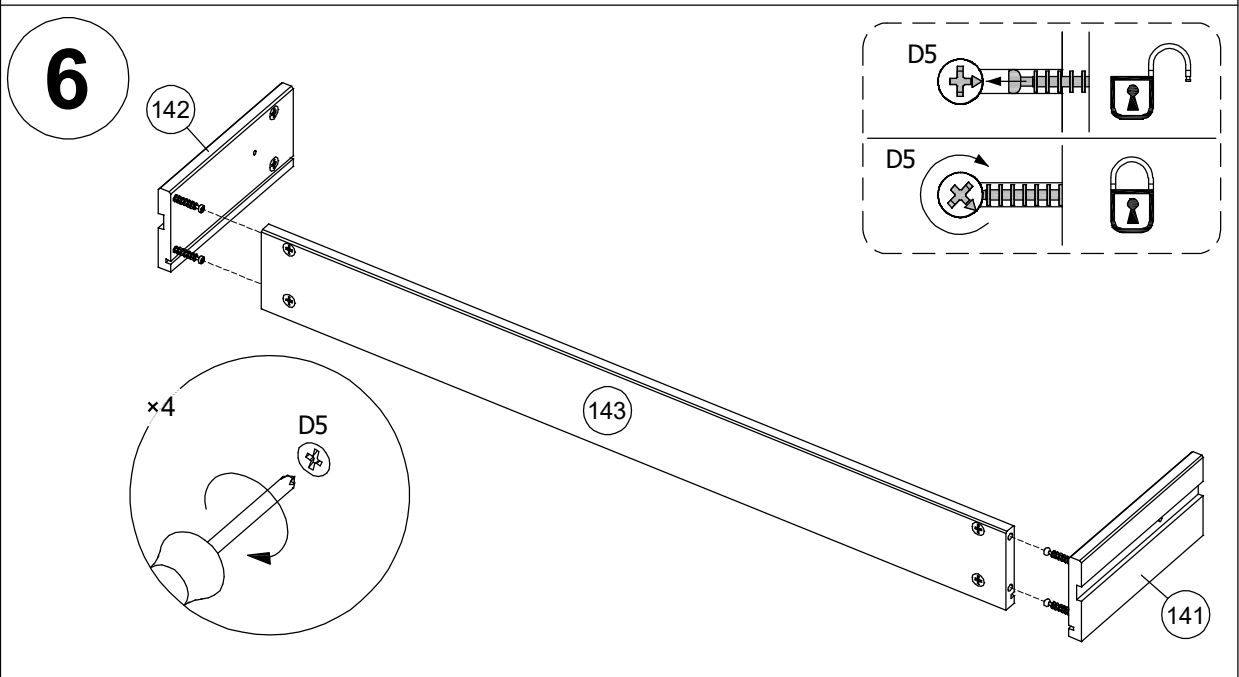
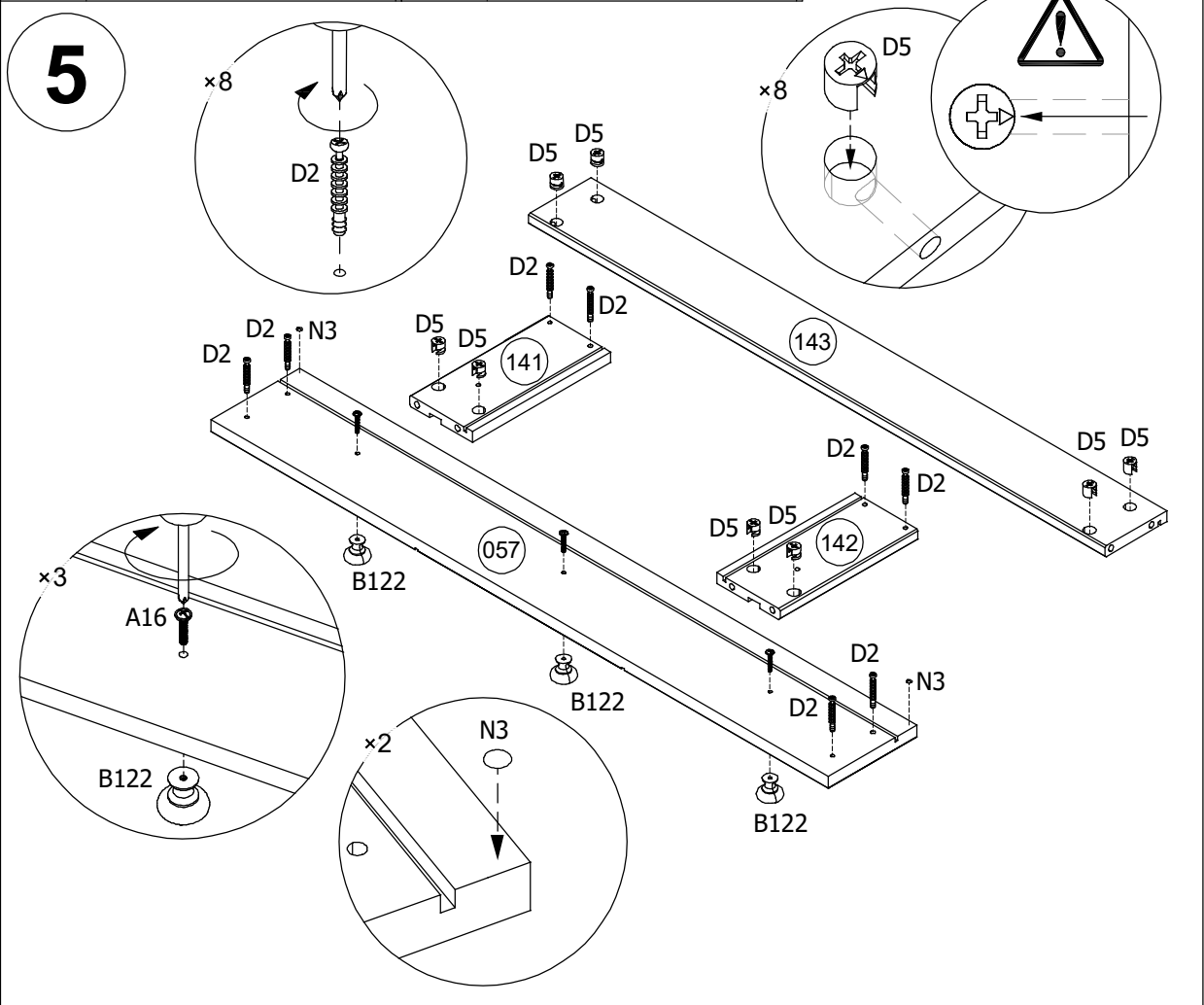

idp12458-1 idp12458-2

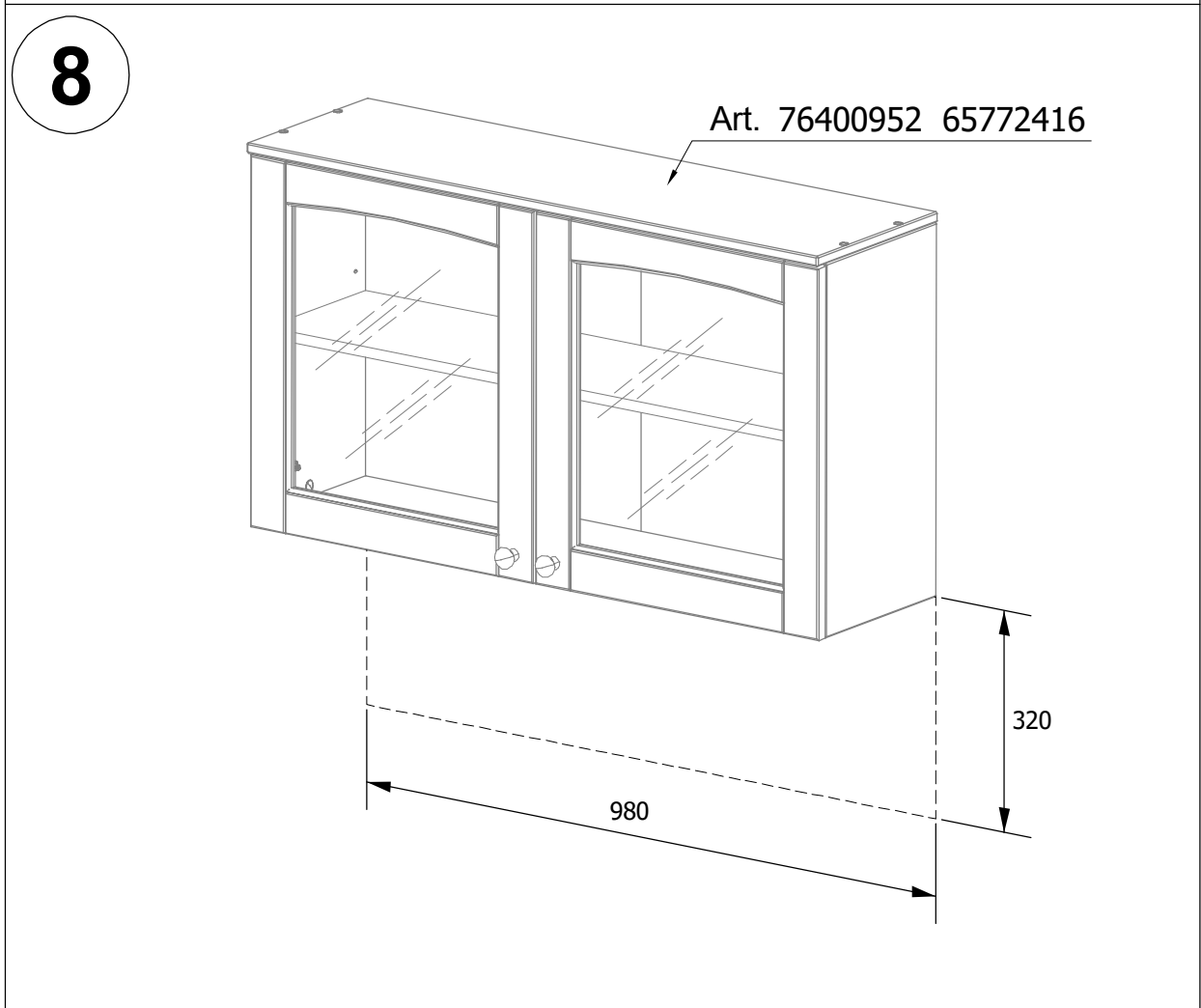
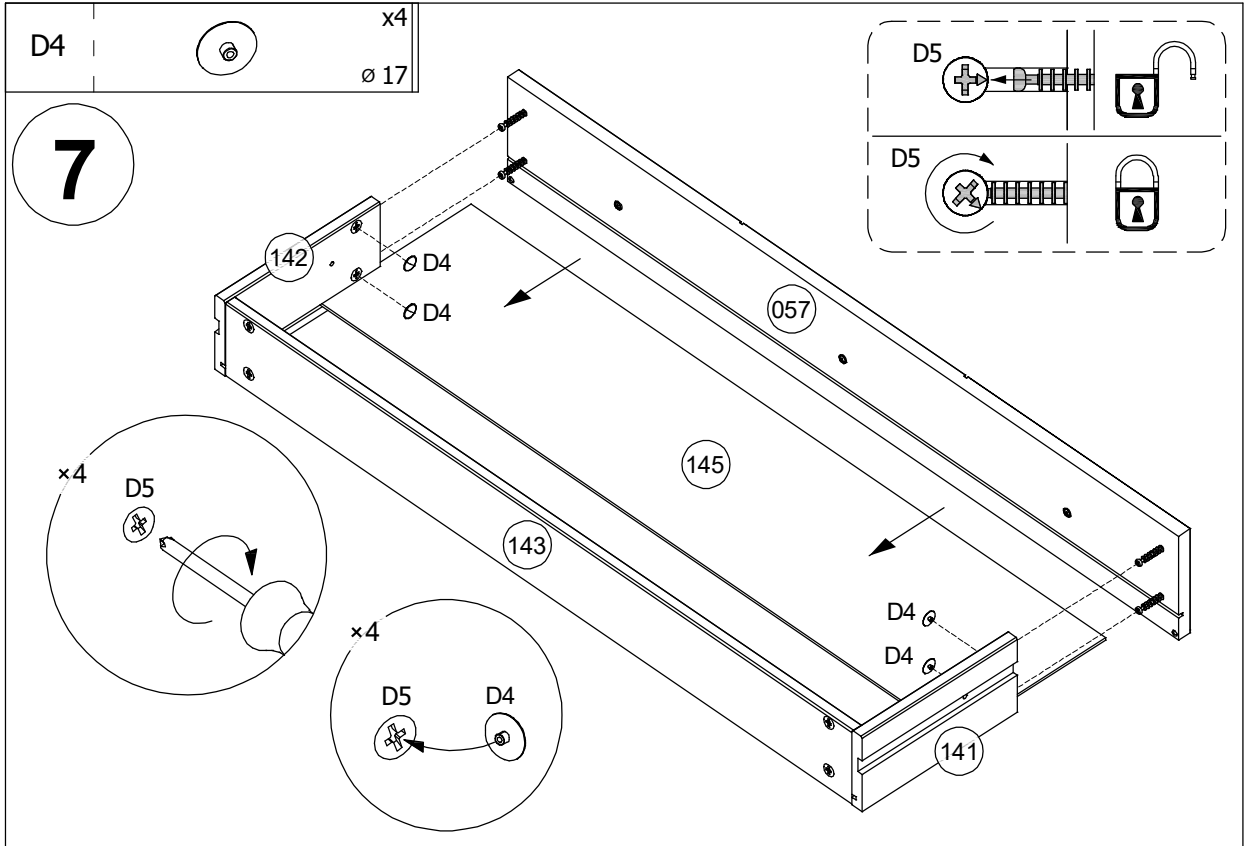

idp12458-1 idp12458-2

9

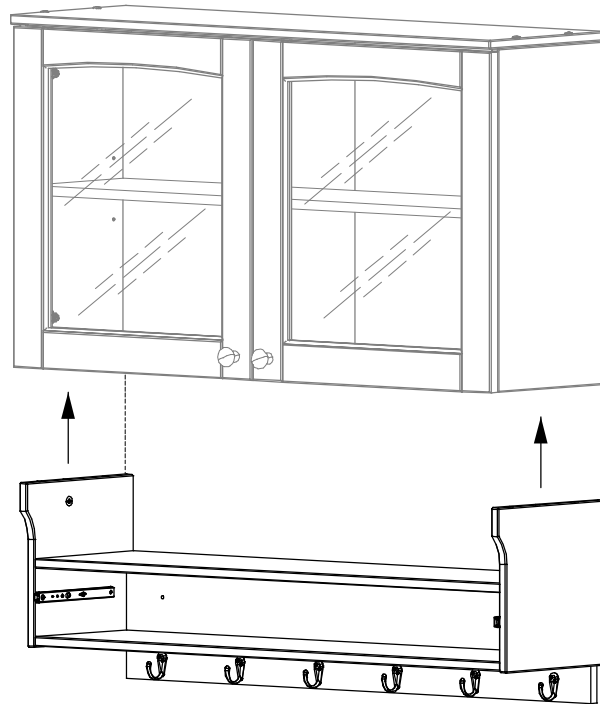
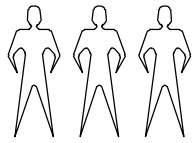

10

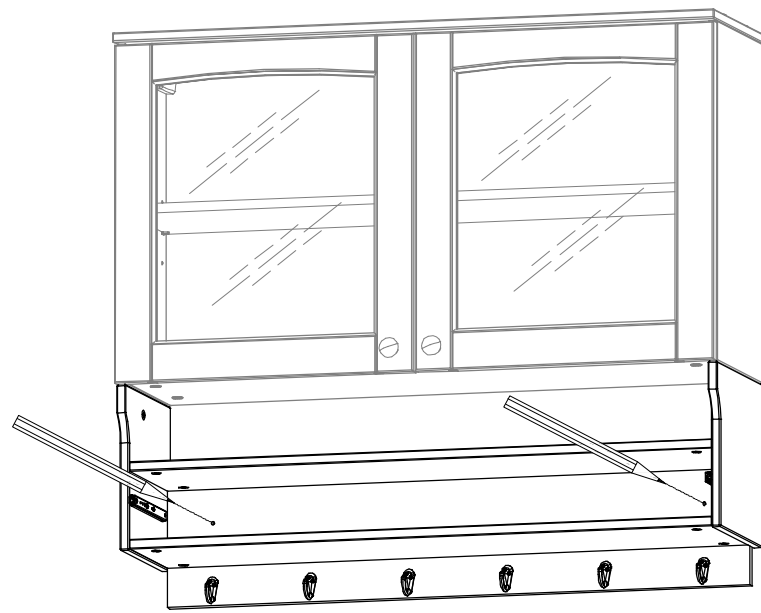
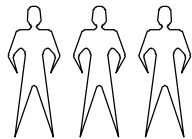

idp12458-1 idp12458-2

11

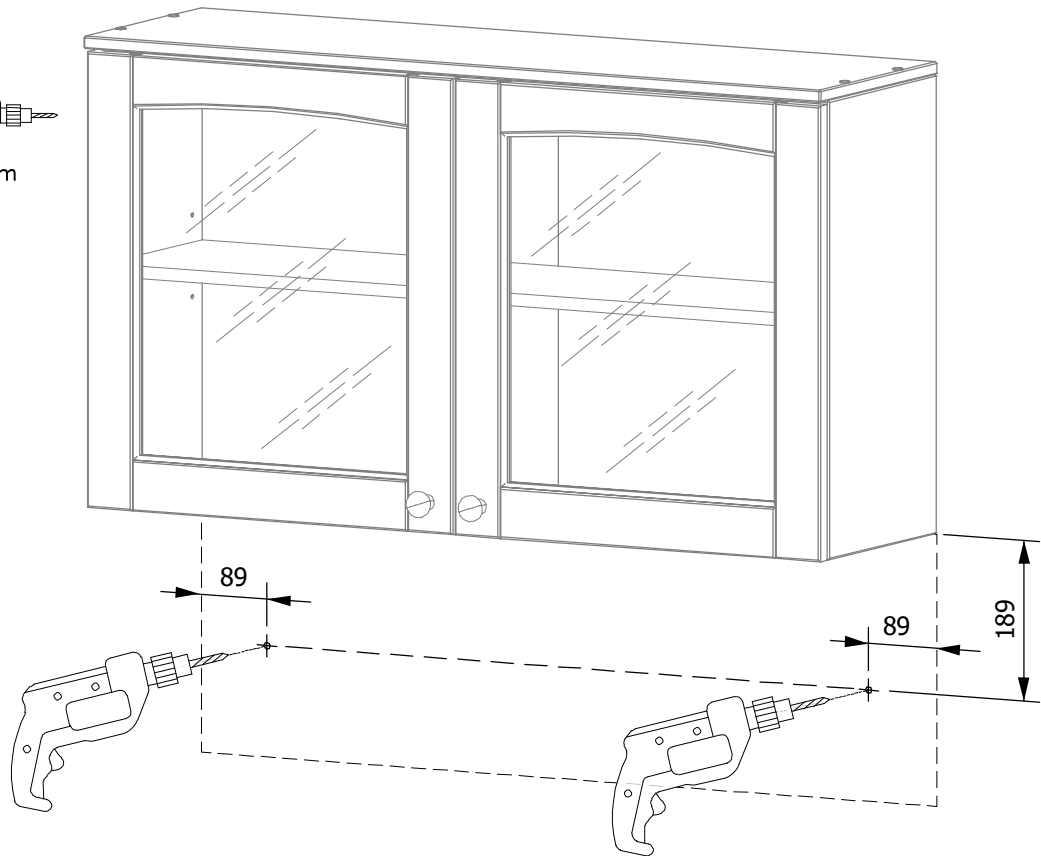
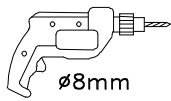

H20 x2
ø8x50

12

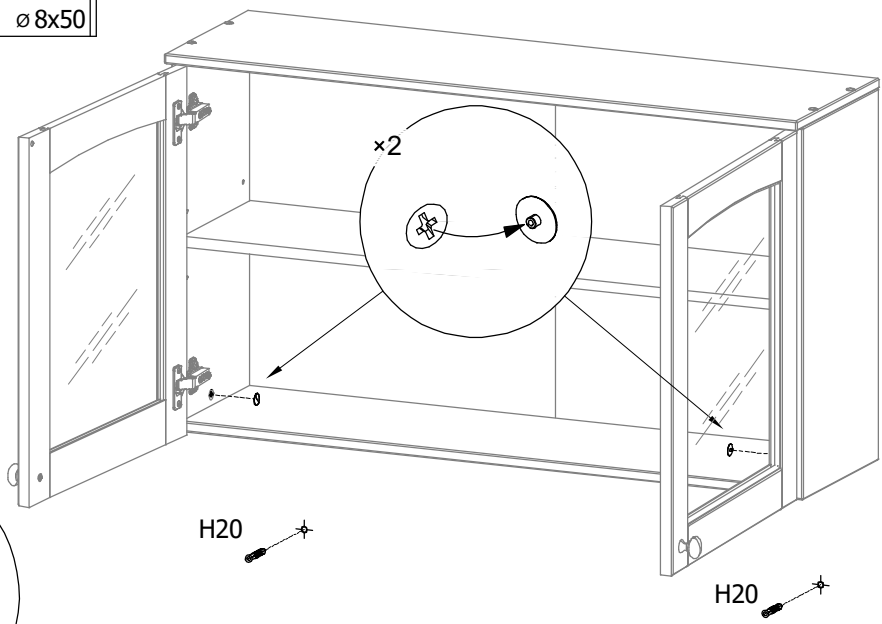
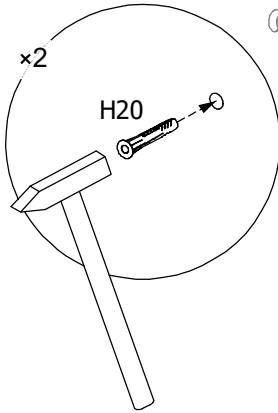

idp12458-1 idp12458-2

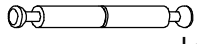
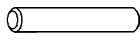
D59		x2	H3		x4
		L=34/34			Ø8x50

13

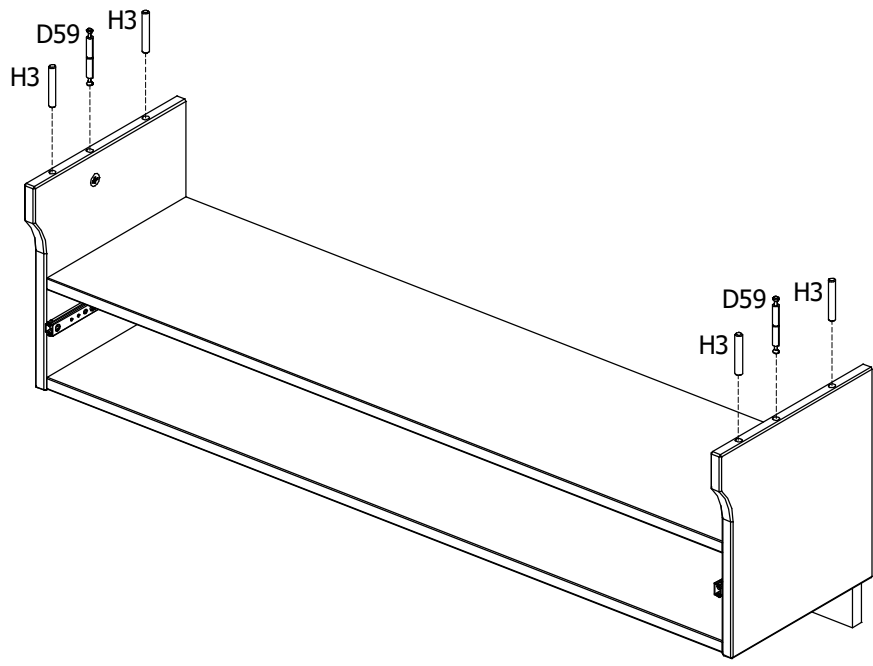

14

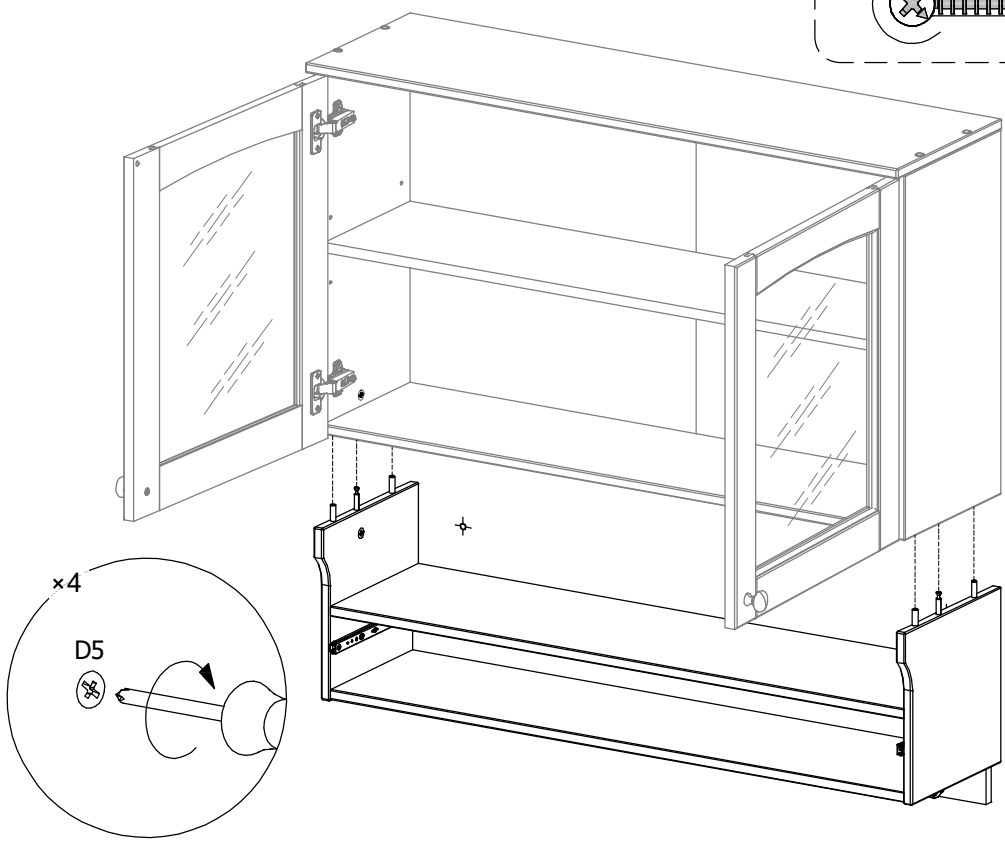
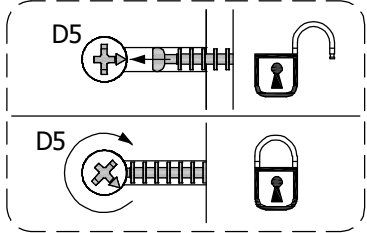
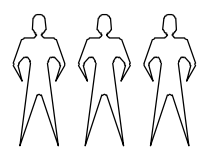

idp12458-1 idp12458-2

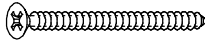
A133  x2
ø 4,5x60

15

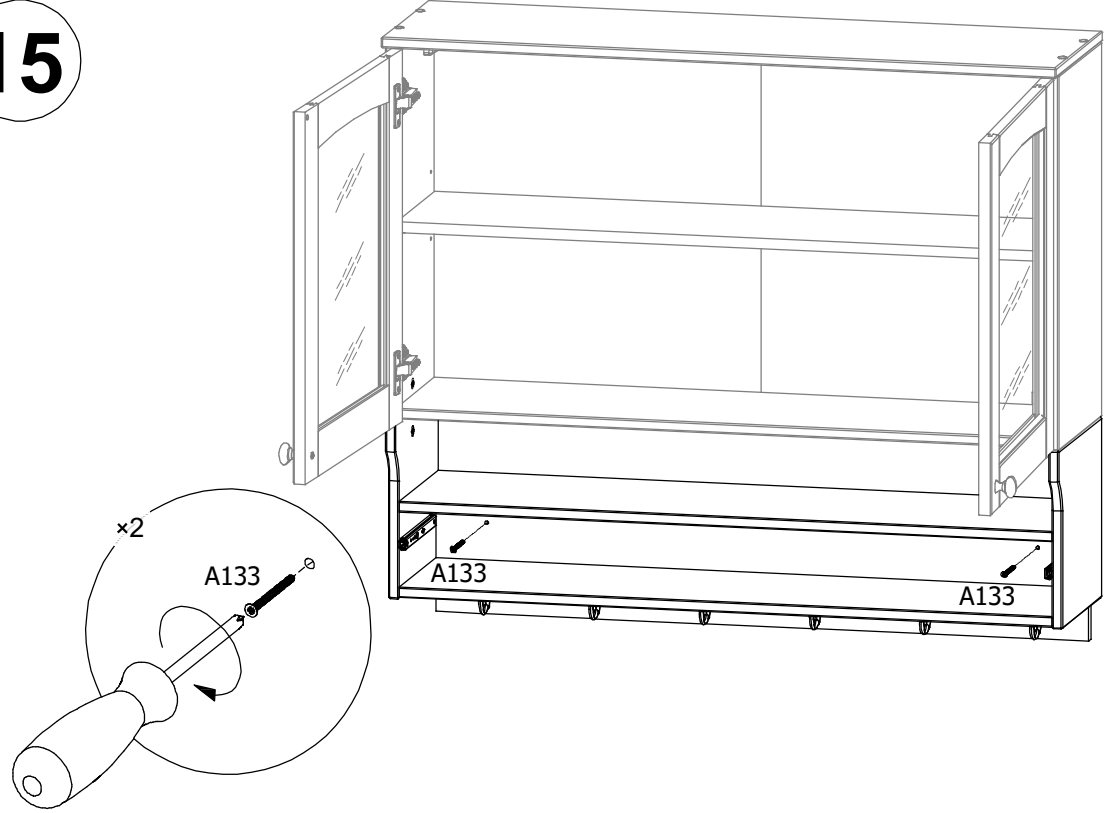

D4  x12
ø 17

16

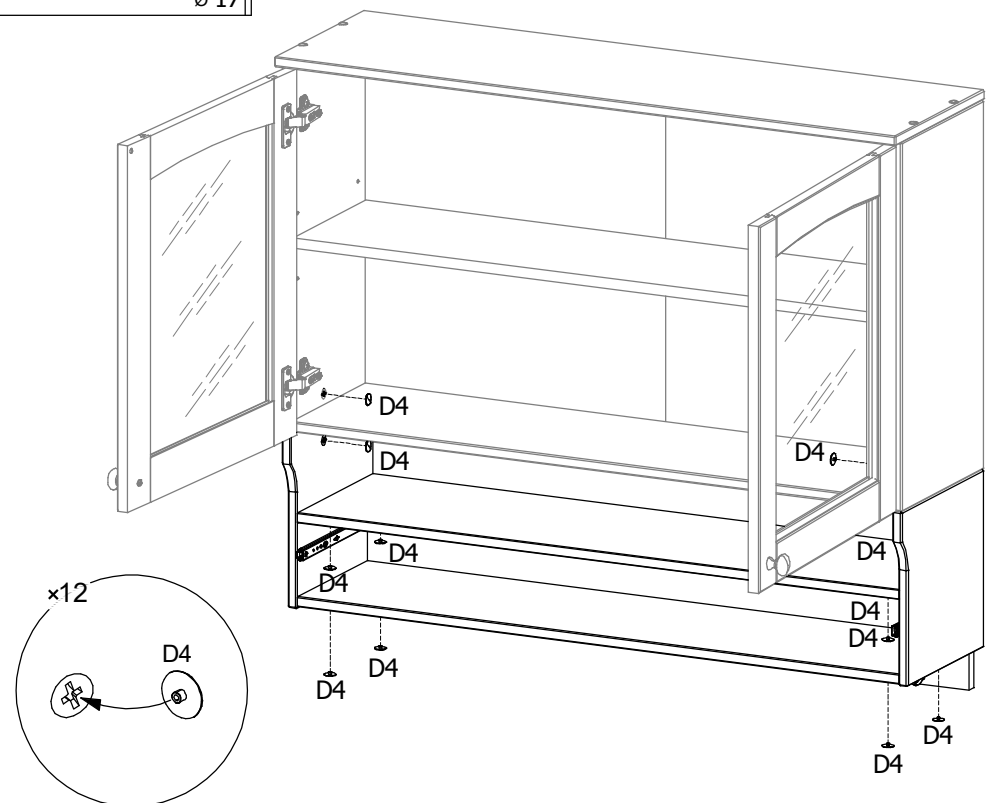

idp12458-1 idp12458-2

A8



x2

M4x12

17

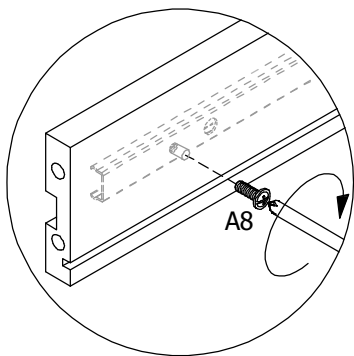
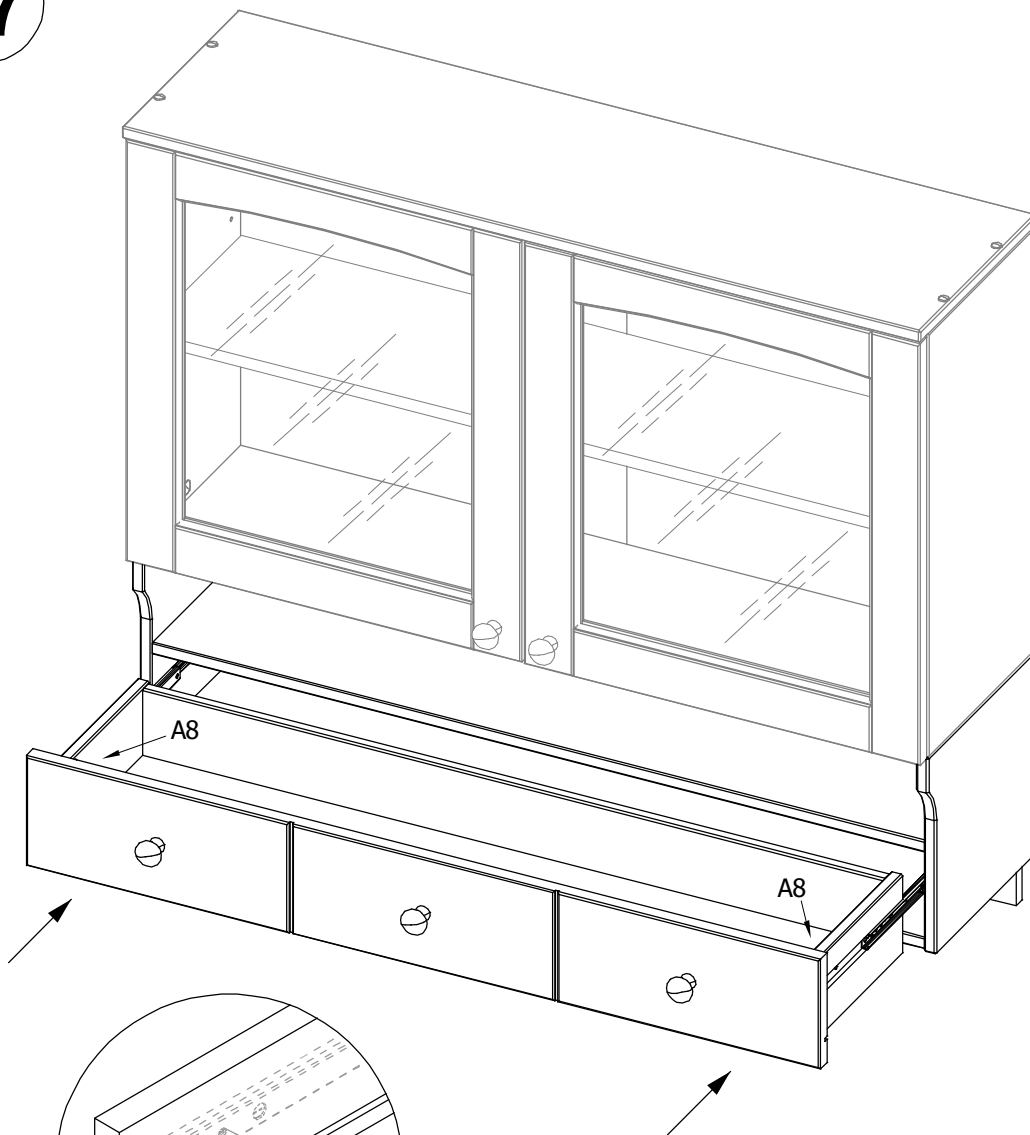

idp12458-1 idp12458-2

H20 

A133 
ø4,5x60

 ø8mm

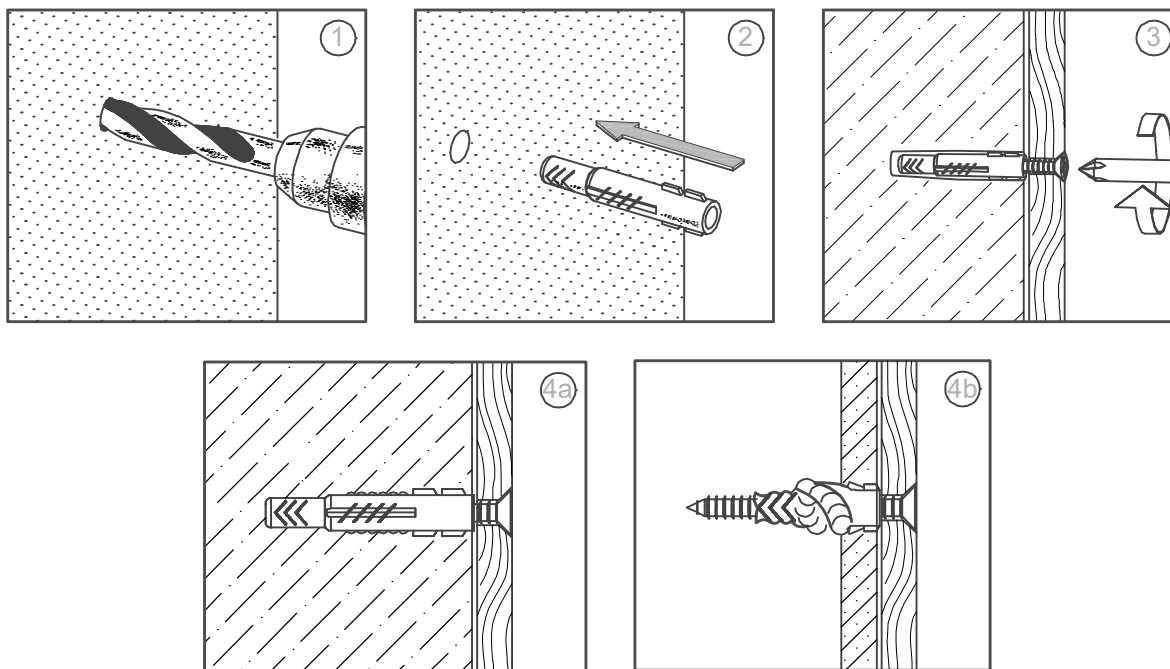

- D** **Achtung:** Die Befestigung des Möbelstückes an der Wand muss von einer fachkundigen Person vorgenommen werden, da für die Montage an die Wand angepasste Dübel erforderlich sind.
- GB** **Attention:** A qualified professional is required when mounting furniture to the wall since dowels corresponding to the wall are required for this.
- FR** **Attention :** La fixation du meuble contre le mur doit être effectuée par une personne compétente car, pour le montage mural, il faut utiliser des chevilles adaptées.
- IT** **Attenzione:** Il fissaggio del mobile alla parete deve essere eseguito da persone esperte, dato che occorrono tasselli adeguati.
- NL** **Opgelet:** een vakkundige persoon dient het meubelstuk aan de muur te bevestigen; voor de montage aan de muur zijn immers aangepaste pluggen vereist.
- PL** **Uwaga:** Mocowanie mebla do ściany mogą przeprowadzić wyłącznie wykwalifikowane osoby, z uwagi na zastosowanie odpowiednio dopasowanych kołków do rodzaju ściany.
- CZ** **Pozor:** Montáž nábytku na stěnu musí provést odborník, protože k montáži na stěnu jsou zapotřebí upravené hmoždinky.
- SK** **Pozor:** Upevnenie nábytku na stenu musí vykonať odborník, nakoľko sú pre montáž na stenu potrebné vhodné hmoždinky.
- HU** **Figyelem:** A bútorelemek falra rögzítését szakembernek kell végeznie, mert a rögzítéshez megfelelő tiplit kell használni.
- RO** **Atenție:** Fixarea la perete a piesei de mobilier se realizează numai de către personal competent, deoarece montajul de perete necesită dibluri adecvate.
- TR** **Dikkat:** Mobilya parçasının duvara sabitlenmesi, duvar montajı için özel uyarlanmış dübeller gerektirdiğinden bu iş sadece bu konuda uzman bir kişi tarafından gerçekleştirilmelidir.
- RU** **Внимание:** Поскольку для монтажа на стене необходимо использовать специальные дюбели, мебель должна быть закреплена на стене квалифицированным персоналом.
- LV** **Uzmanību:** Mēbeles montāžai pie sienas paredzēts izmantot speciālus dībeļus. Ietecams šo darbu veikt kvalificētam darbiniekam.

Art. 76400952 65772416

LKZ 75007

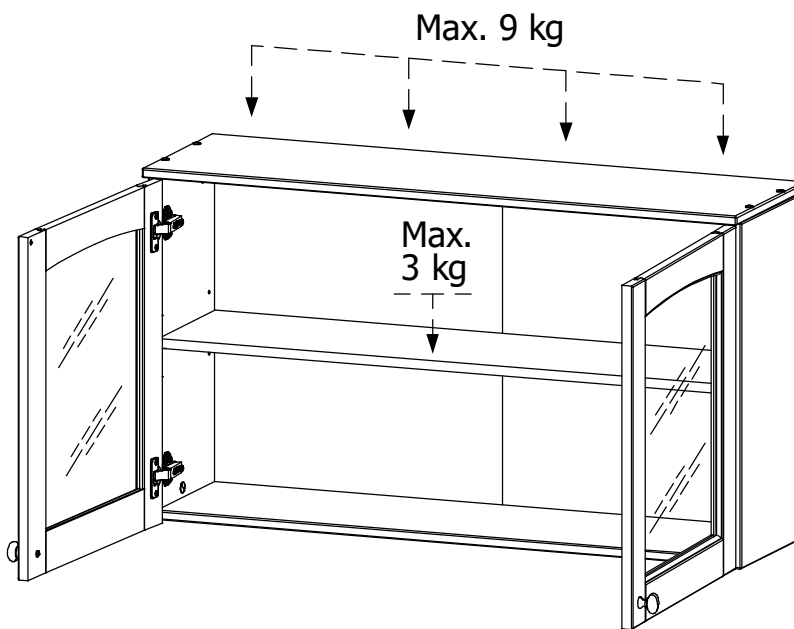
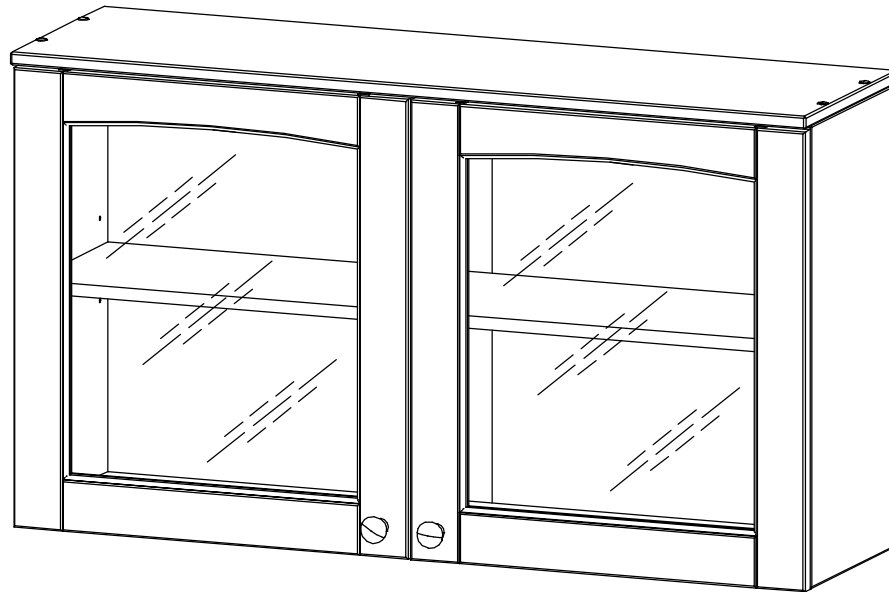
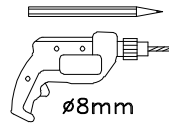
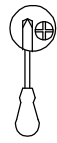
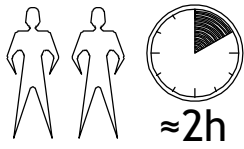

idp68238-1 idp68238-2

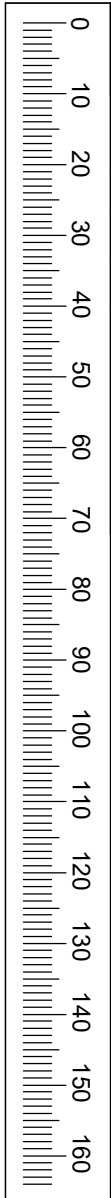

Service • Assistenza • Dienstverlening • Serwis
 Servis • Szerviz • Сервисная служба

Name • Nom • Nome • Naam
 Nazwa • Jméno • Názov • Név
 Denumire • Isim • Название

Nr • No • N • Номер • Č • Sz

Tur • Ture • Тір • Тірус • Тіро
 Тип

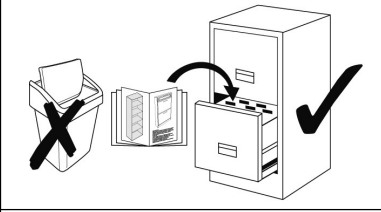
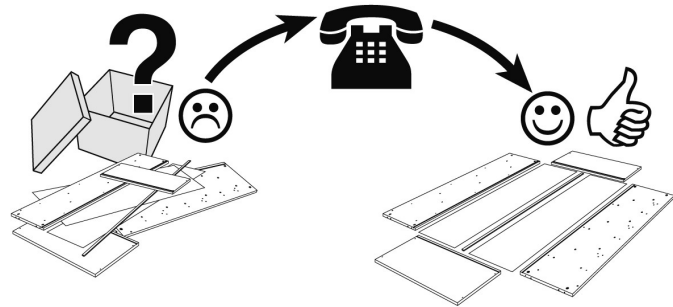



		D5		x6 ø 15x12,5	H1		x8 ø 8x30	
D1		x4 ø 5	D4		x6 ø 17	D2		x4 ø 5/11x34
A5		x1 SW4	D24		x4 ø 13	A27		x4 ø 7x50
N3		x2 ø 7x1,5	B122		x2	A16		x2 M4x25
G101		x4 2mm	G98		x4 ø 35	A1		x8 ø 3,5x15
D48		x2	H20		x4 ø 8x50	A133		x4 ø 4,5x60
D141		x1 Right	D142		x1 Left	A108		x4 ø 4x15
D144		x1 Right	D143		x1 Left	D36		x8 15x15x10

idp68238-1 idp68238-2

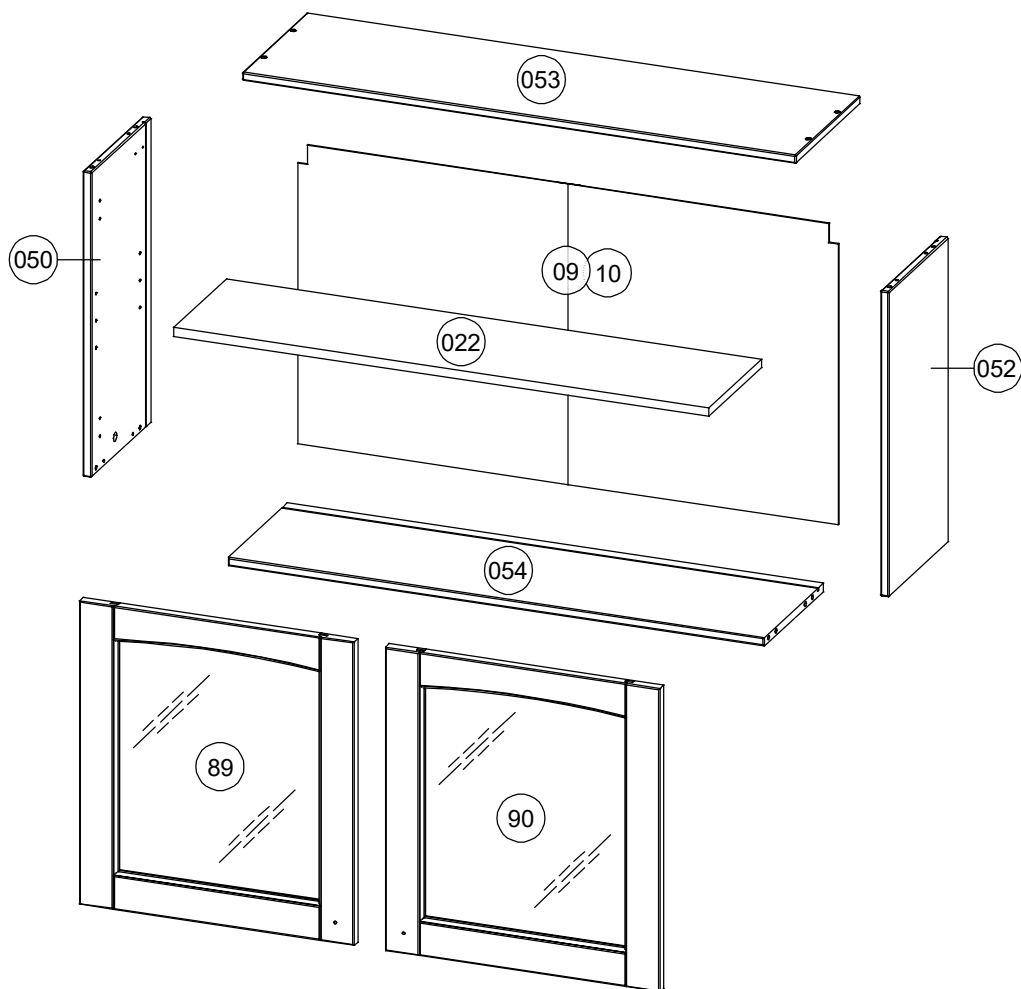

Teil Nr. Pièces Nr. Pieces Nr. Часть Ном. Kawalek Nr. Parça No Kusů Nr. Kusov Nr. Pezzi Nr. Nr piese. Darab száma. Stukken Nr. Kārtas Nr.	Anzahl Quantité Quantity Количество Ilość Miktar Množství Množstvo Quantità Cantitatea Mennyiség Hoeveelheid Skaitis	Kasten Nr. Colli Nr. Colli Nr. Коробка Ном. Polu Nr. Kutusu Nr. Kolonka Č. Počet balení Colli Nr. Nu pachete Colli száma. Colli Nr. Kastes Nr.	Maß, mm Dimensions, mm Dimensions, mm Размеры, mm Wymiary, mm Boyutlar, mm Rozměry, mm Rozmery, mm Dimensioni, mm Dimensiuni, mm Méretek, mm Afmetingen, mm Izmēri, mm	✓
050	1	1 / 1	540 x 260 x 15	
052	1	1 / 1	540 x 260 x 15	
053	1	1 / 1	980 x 282 x 15	
054	1	1 / 1	948 x 260 x 15	
022	1	1 / 1	947 x 232 x 15	
09 (10)	1	1 / 1	956 x 530 x 3	
89	1	1 / 1	536 x 486 x 18	
90	1	1 / 1	536 x 486 x 18	

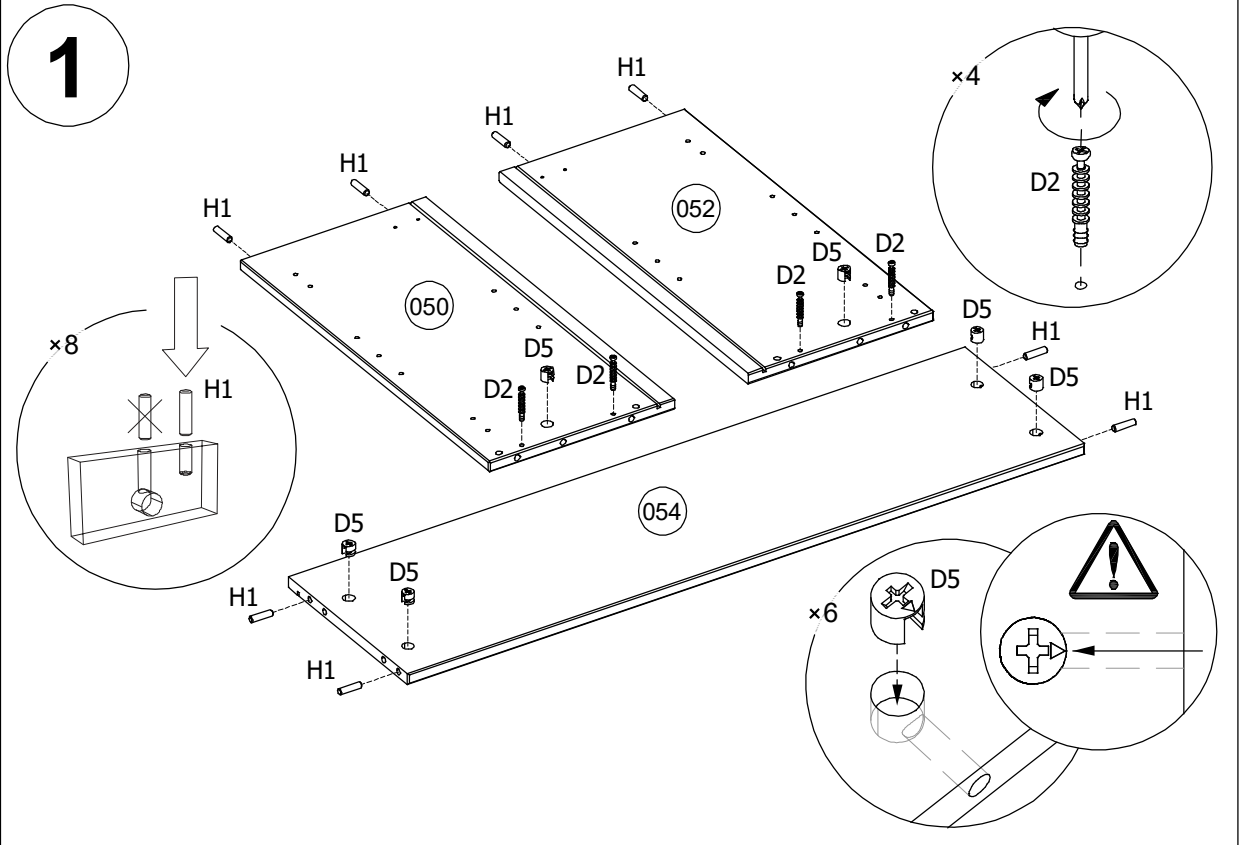

idp68238-1 idp68238-2

H1		x8 ø 8x30	D2		x4 ø 5/11x34	D5		x6 ø 15x12,5
----	---	--------------	----	---	-----------------	----	---	-----------------

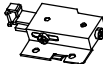

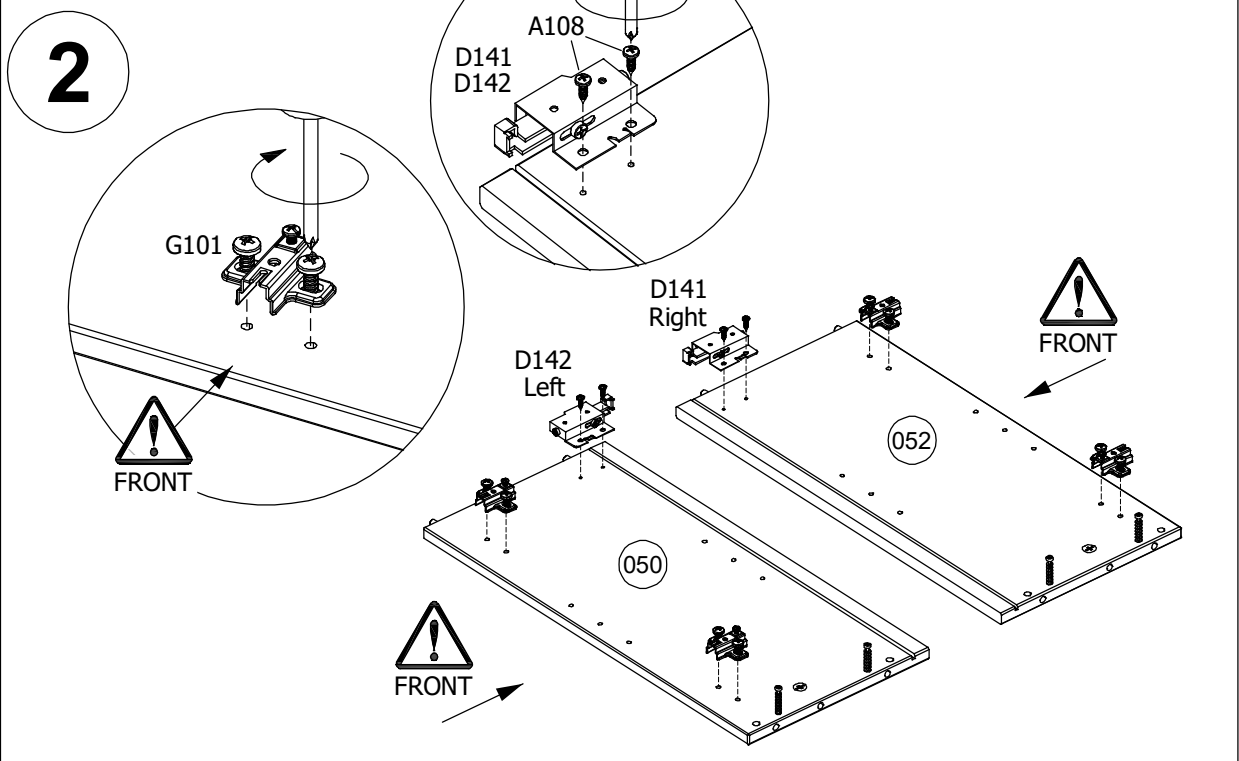

D142		x1 Left	D141		x1 Right	A108		x4 ø 4x15
G101		x4 2mm						

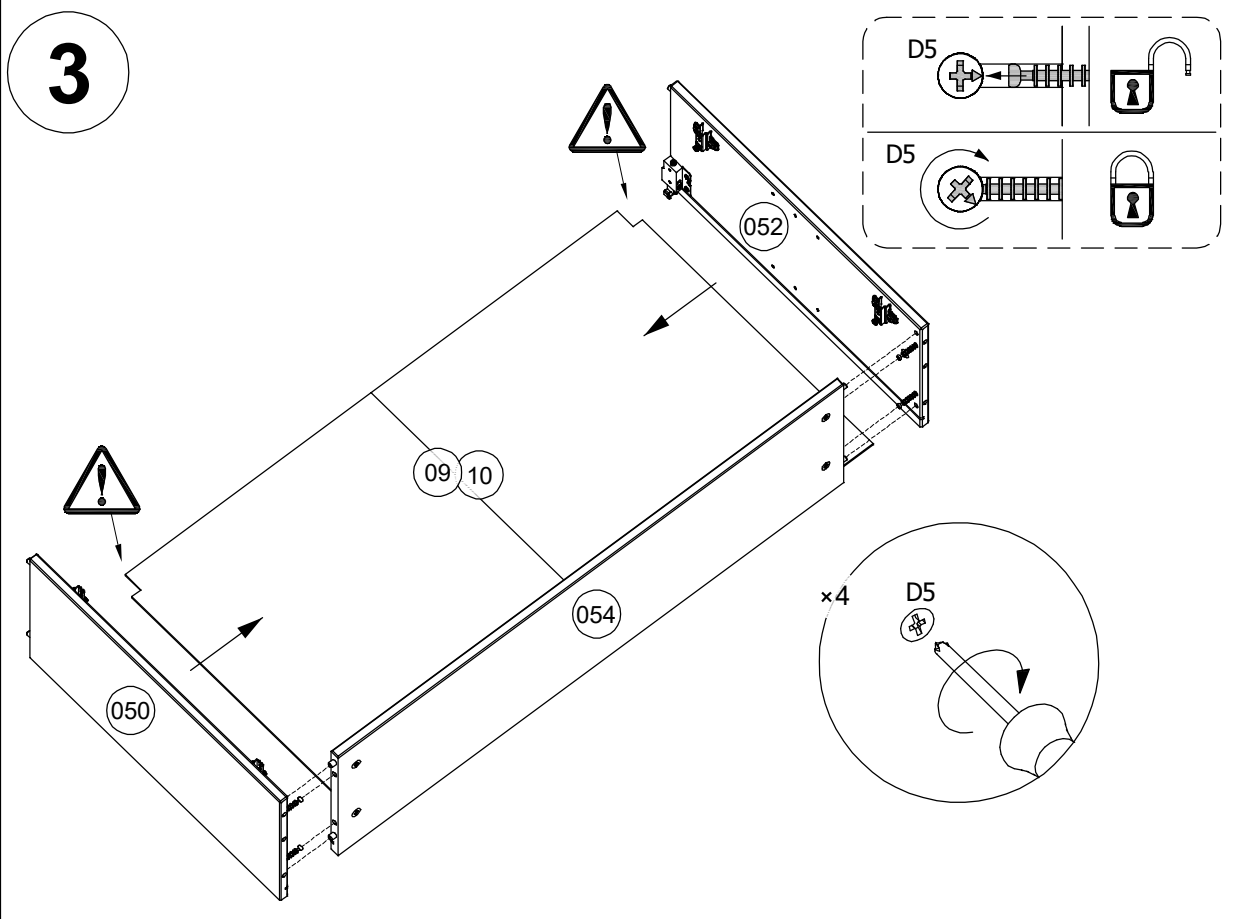

idp68238-1 idp68238-2

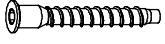
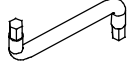

A27		x4	A5		x1	D24		x4
	ø7x50			SW4			Ø13	

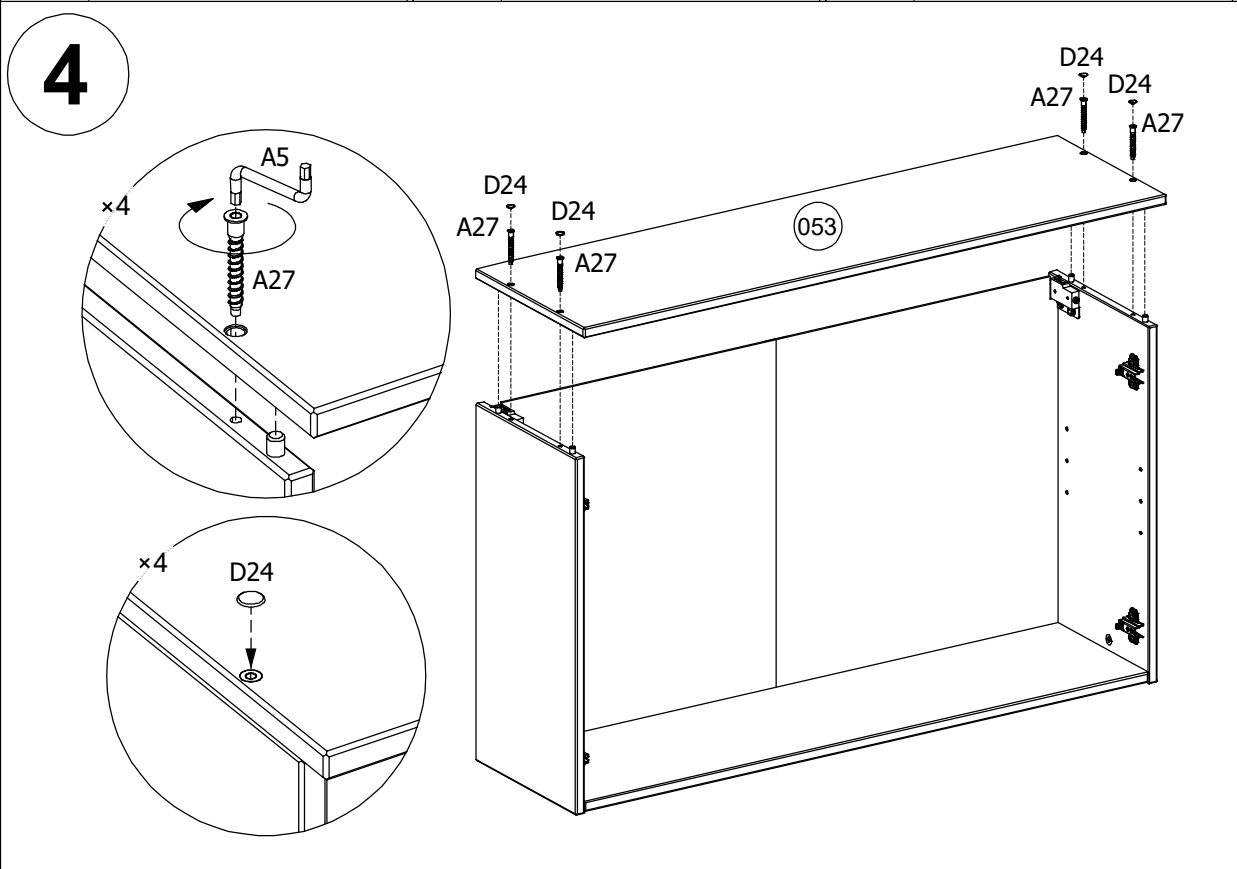

idp68238-1 idp68238-2

D36



x8

15x15x10

5

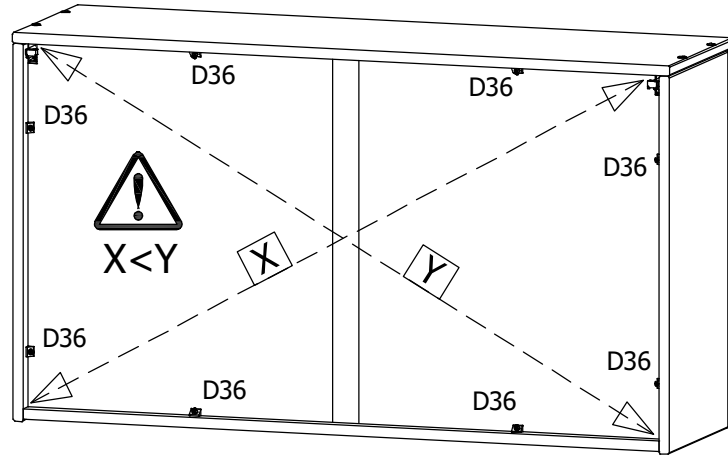
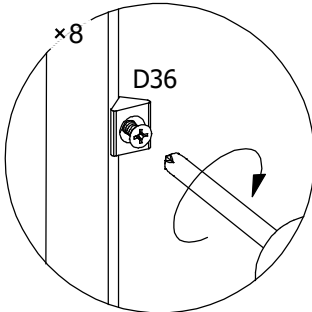
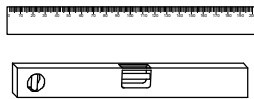

D48

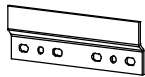

x2

H20



x4

ø 8x50

A133

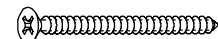

x4

ø4,5x60

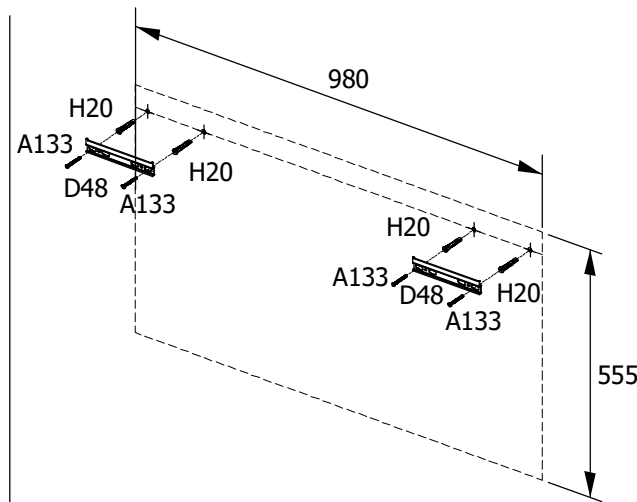
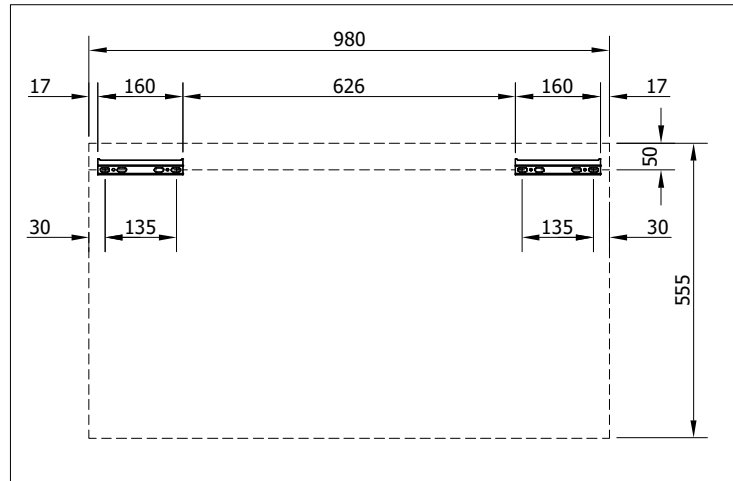
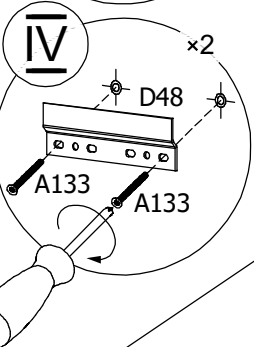
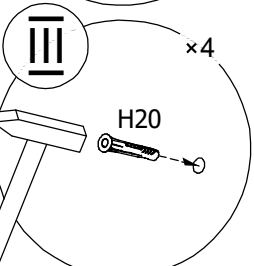
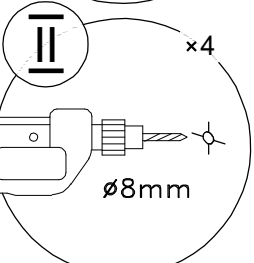
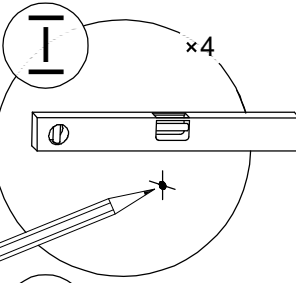

6

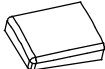
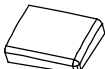

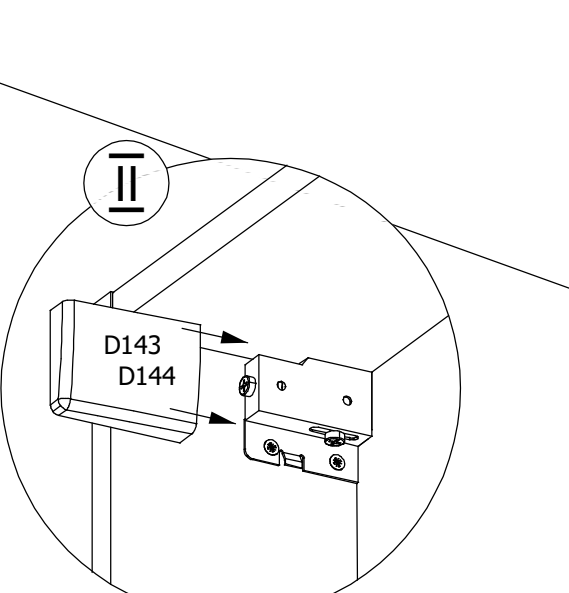
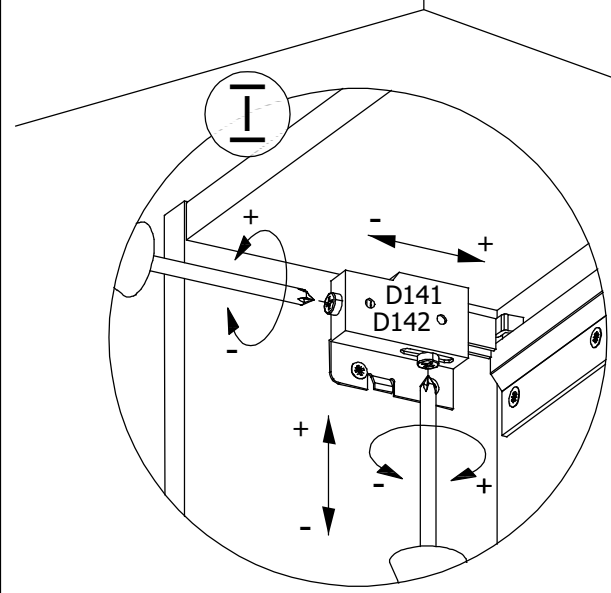
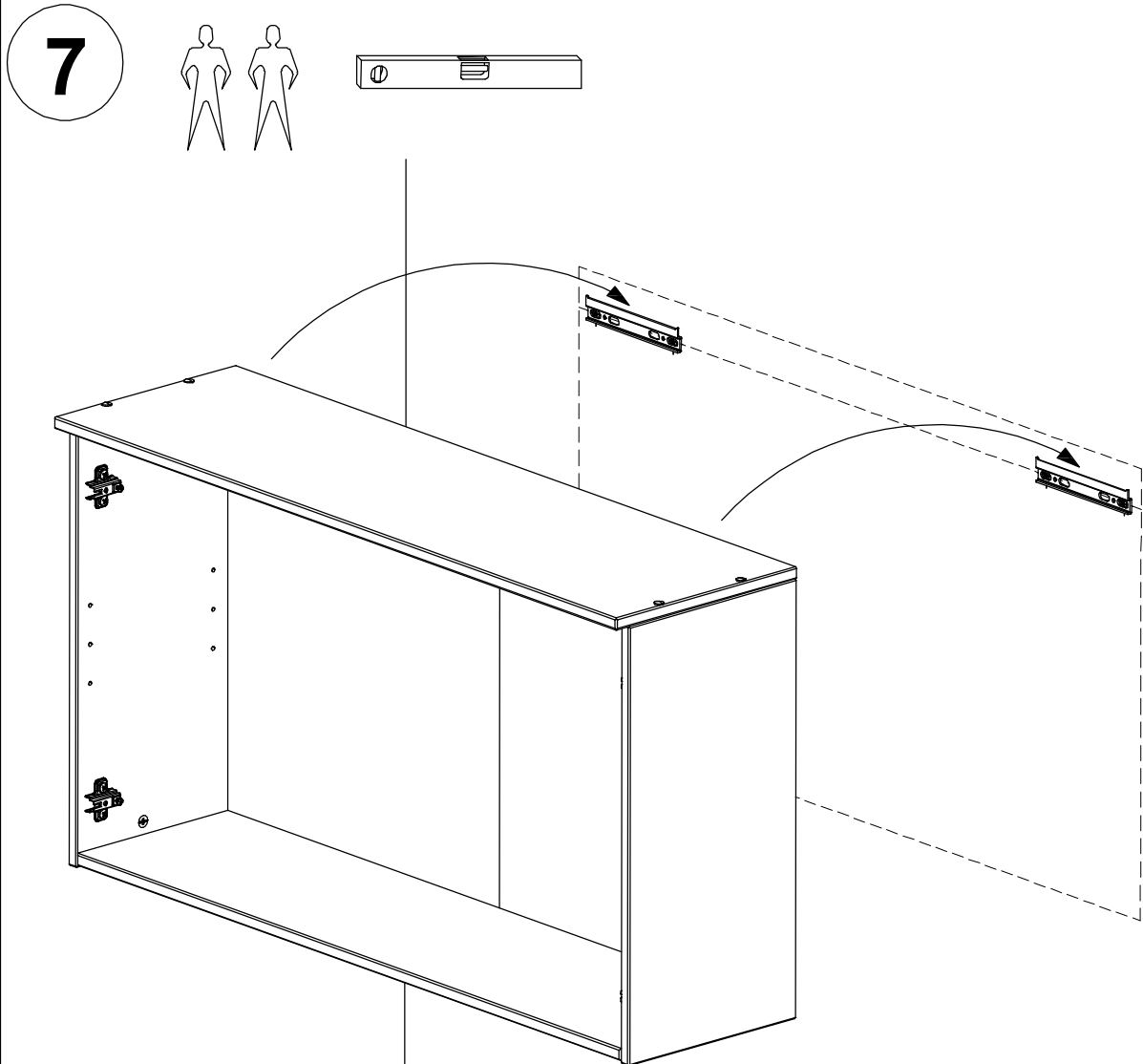
D143		x1	D144		x1
		Left			Right



idp68238-1 idp68238-2

D1		x4 ø5	D4		x6 ø17
----	---	----------	----	---	-----------



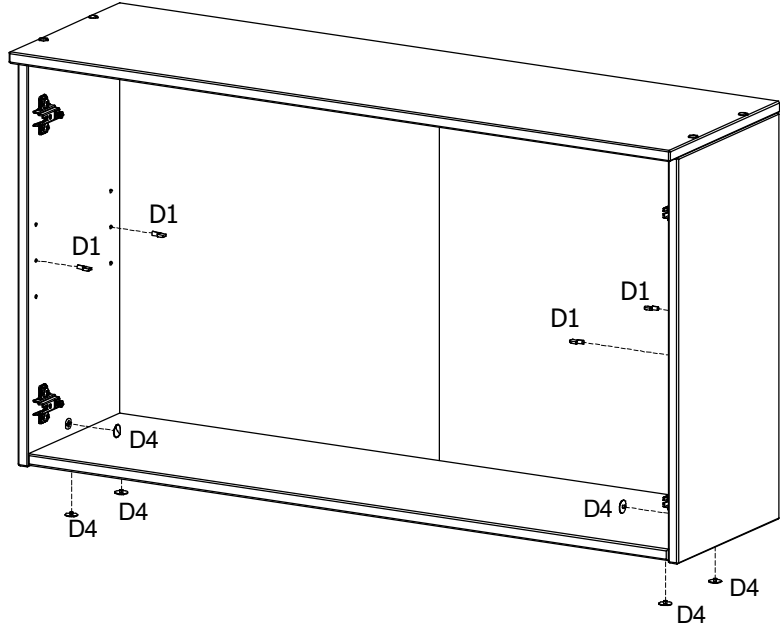
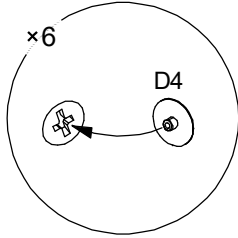
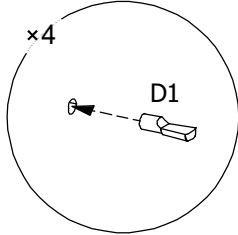

8

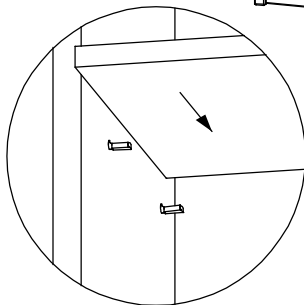
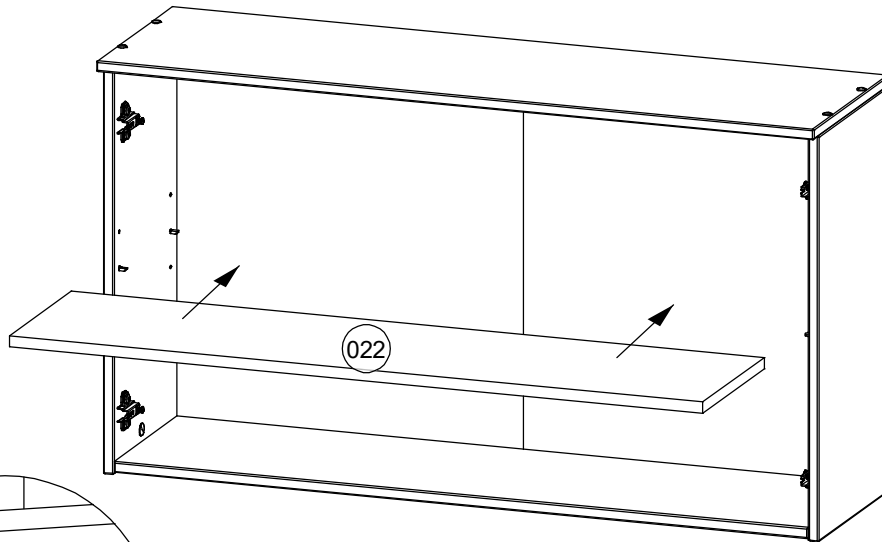

9

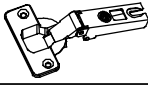

idp68238-1 idp68238-2

G98		x4 ø35	A1		x8 ø 3,5x15	N3		x2 Ø7x1,5
B122		x2	A16		x2 M4x25			

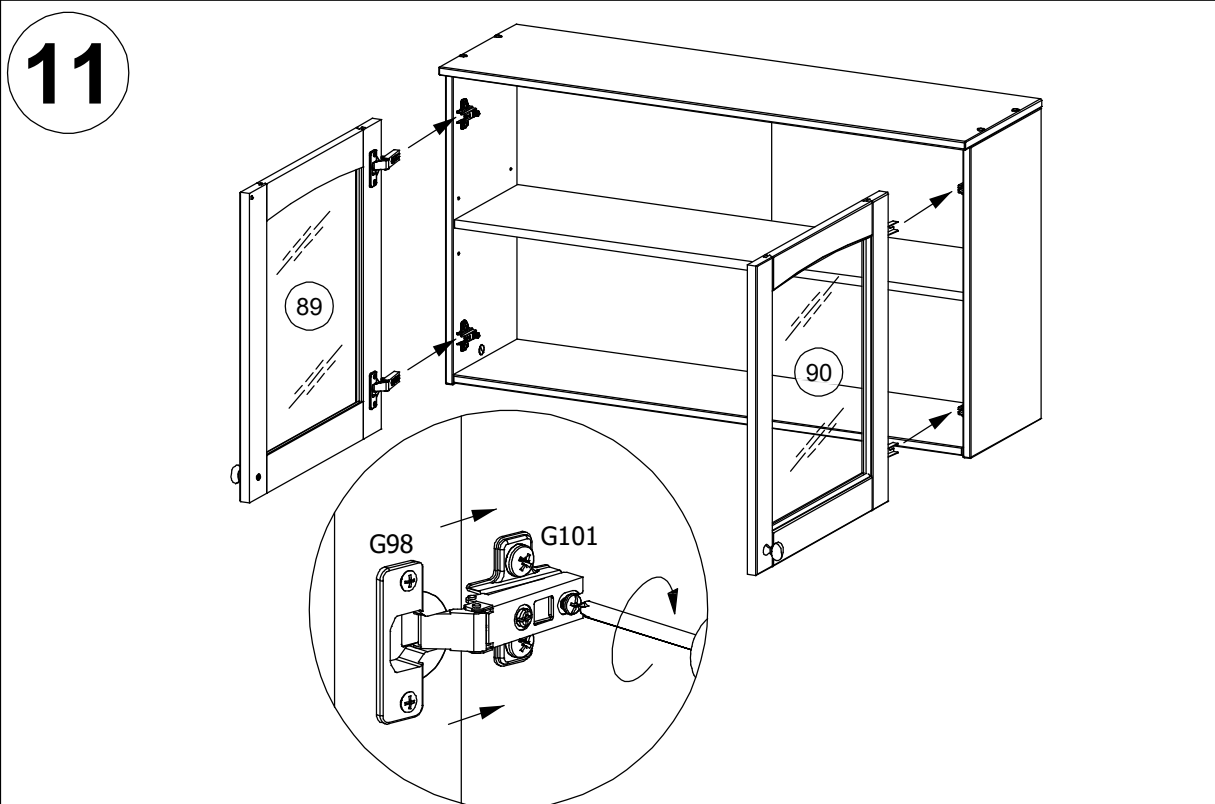
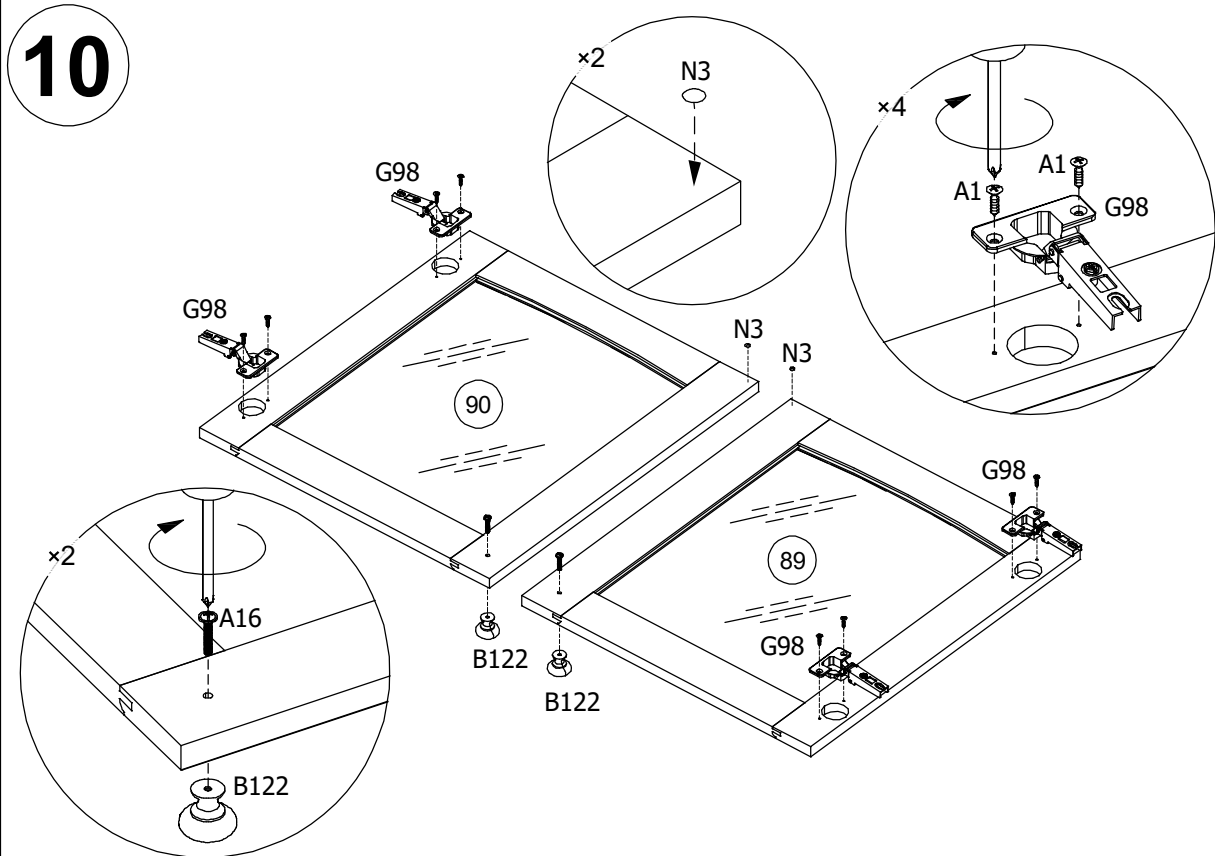

idp68238-1 idp68238-2

H20 

A133 
 ø4,5x60

 ø8mm

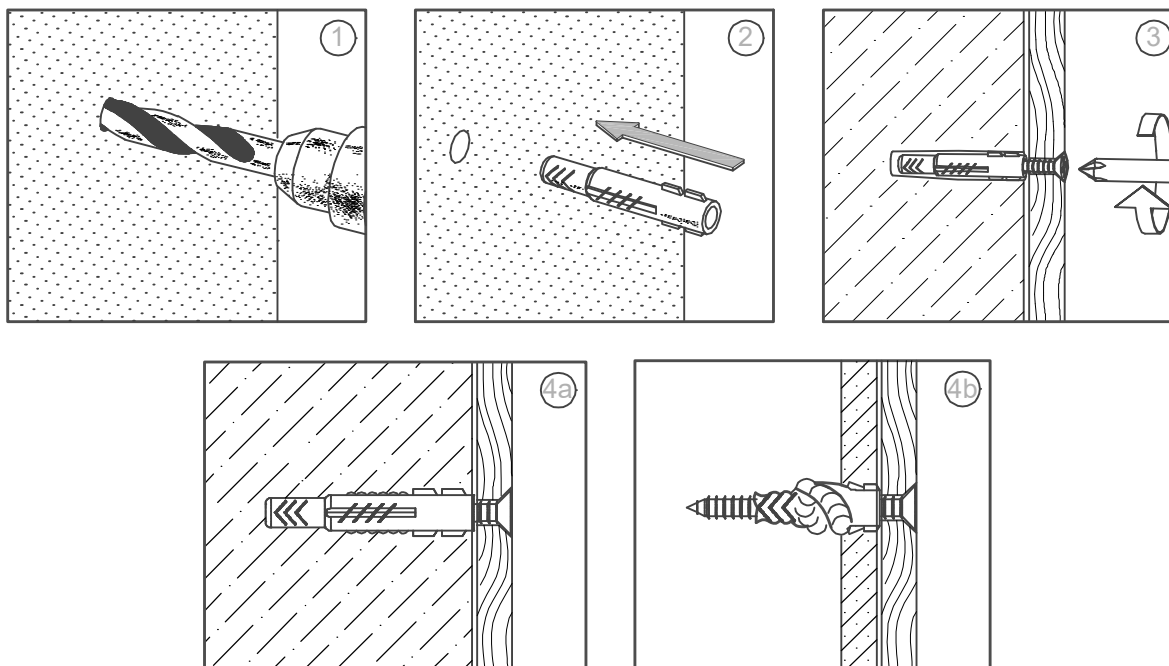

- D** **Achtung:** Die Befestigung des Möbelstückes an der Wand muss von einer fachkundigen Person vorgenommen werden, da für die Montage an die Wand angepasste Dübel erforderlich sind.
- GB** **Attention:** A qualified professional is required when mounting furniture to the wall since dowels corresponding to the wall are required for this.
- FR** **Attention :** La fixation du meuble contre le mur doit être effectuée par une personne compétente car, pour le montage mural, il faut utiliser des chevilles adaptées.
- IT** **Attenzione:** Il fissaggio del mobile alla parete deve essere eseguito da persone esperte, dato che occorrono tasselli adeguati.
- NL** **Opgelet:** een vakkundige persoon dient het meubelstuk aan de muur te bevestigen; voor de montage aan de muur zijn immers aangepaste pluggen vereist.
- PL** **Uwaga:** Mocowanie mebla do ściany mogą przeprowadzić wyłącznie wykwalifikowane osoby, z uwagi na zastosowanie odpowiednio dopasowanych kołków do rodzaju ściany.
- CZ** **Pozor:** Montáž nábytku na stěnu musí provést odborník, protože k montáži na stěnu jsou zapotřebí upravené hmoždinky.
- SK** **Pozor:** Upevnenie nábytku na stenu musí vykonať odborník, nakoľko sú pre montáž na stenu potrebné vhodné hmoždinky.
- HU** **Figyelem:** A bútorelemek falra rögzítését szakembernek kell végeznie, mert a rögzítéshez megfelelő tiplít kell használni.
- RO** **Atenție:** Fixarea la perete a piesei de mobilier se realizează numai de către personal competent, deoarece montajul de perete necesită dibluri adecvate.
- TR** **Dikkat:** Mobilya parçasının duvara sabitlenmesi, duvar montajı için özel uyarlanmış dübeller gerektirdiğinden bu iş sadece bu konuda uzman bir kişi tarafından gerçekleştirilmelidir.
- RU** **Внимание:** Поскольку для монтажа на стене необходимо использовать специальные дюбели, мебель должна быть закреплена на стене квалифицированным персоналом.
- LV** **Uzmanību:** Mēbeles montāžai pie sienas paredzēts izmantot speciālus dībeļus. Ietecams šo darbu veikt kvalificētam darbiniekam.

- ⒸZ Úprava dverí
- Ⓓ Das Richten einer Türe
- Ⓕ Réglage d'une porte.
- ⒽU Beállítás egy ajtó
- Ⓘ Regolare una porta
- Ⓕ Durvju regulēšana
- ⒼNL Instellen van een deur
- ⒼPL Regulacja drzwi
- ⒼRO Reglarea o ușă
- ⒼRU Регулировка Дверей
- ⒼSK Úprava dverí
- ⒼTR Bir kapı ayarlama
- ⒼUK Adjusting a door
- ⒼFIN Oven säätö

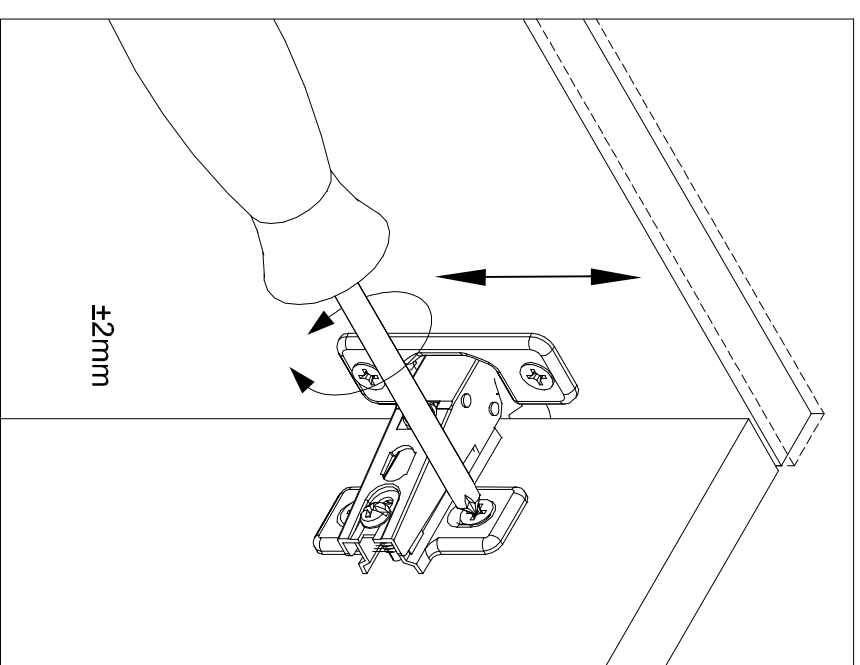
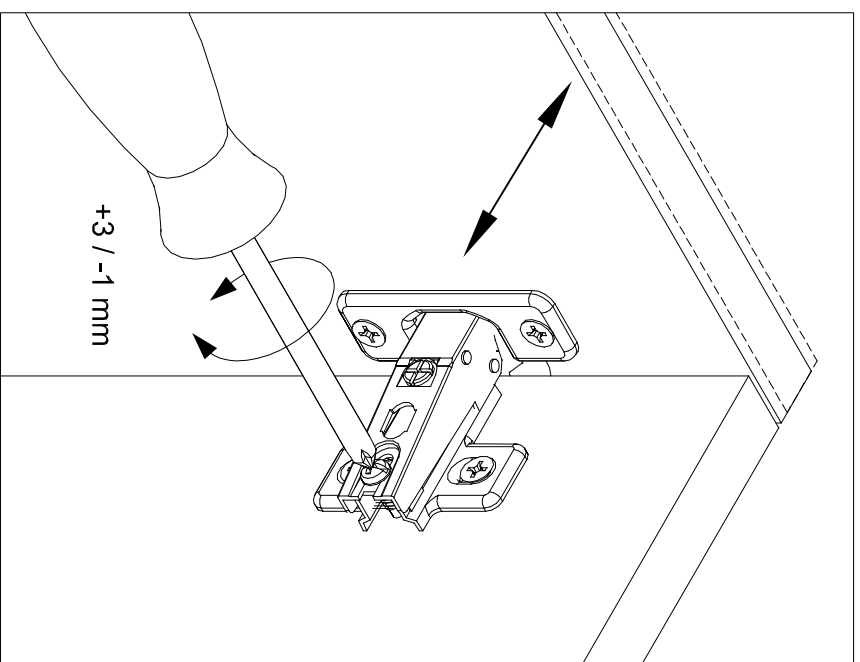
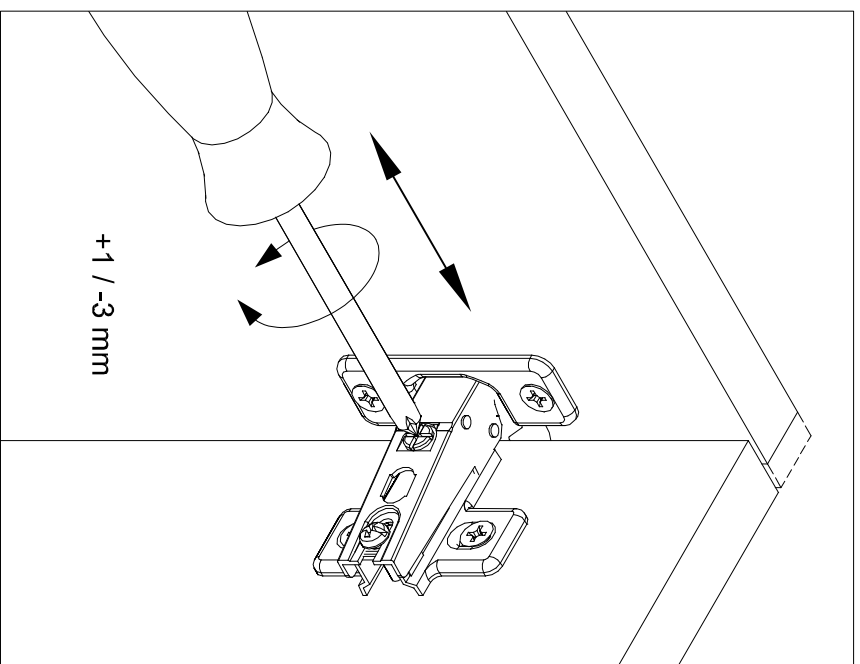

Art. 44492021 63557367

LKZ 75007

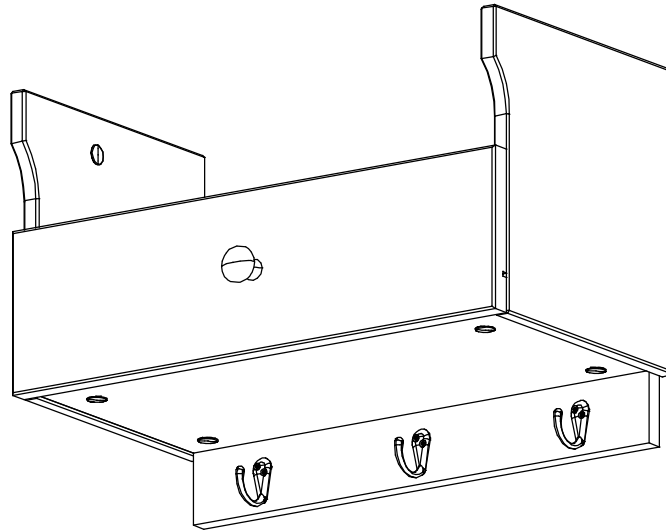
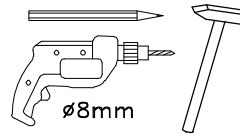
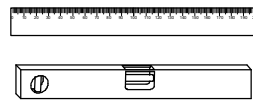
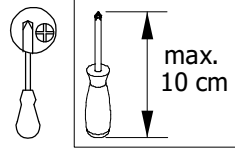
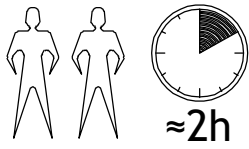



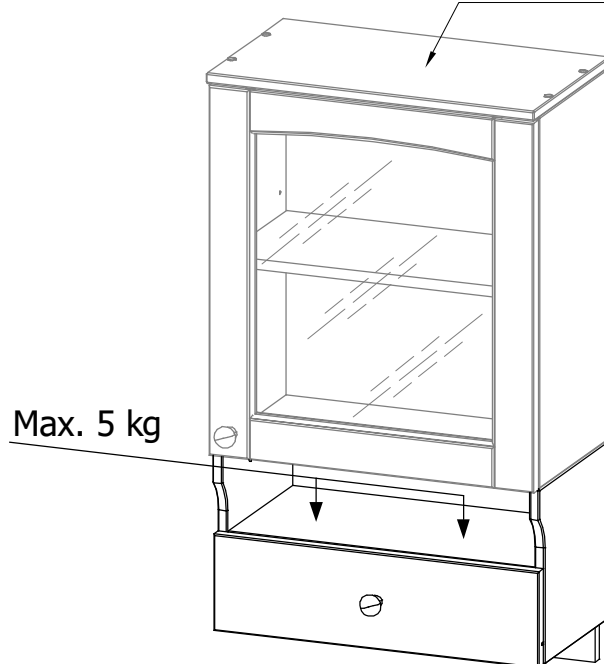



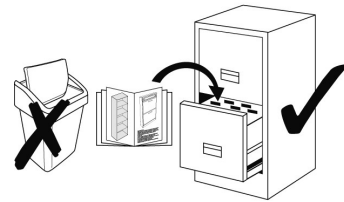
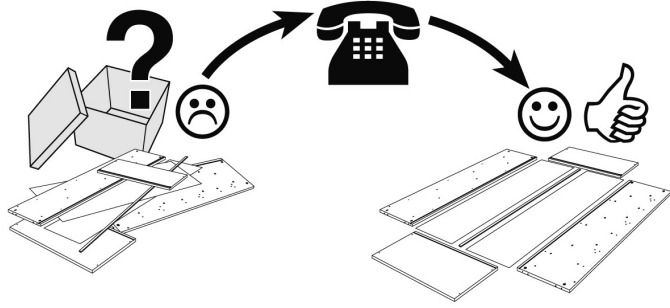



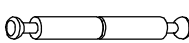
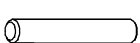



Art. 70512937 24197526



idp12459-1 idp12459-2

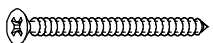

Service • Assistenza • Dienstverlening • Serwis Servis • Szerviz • Сервисная служба	
Name • Nom • Nome • Naam Nazwa • Jméno • Názov • Név Denumire • Isim • Название	
Nr • No • N • Номер • Č • Sz	
Tur • Туре • Тір • Тірус • Тіро Тип	
	
	

				H1		x10 ø 8x30
D2	 x16 ø 5/11x34	D59	 x2 L=34/34	H3		x4 Ø8x50
D317	 x20 ø 15x12	B122	 x1	A16		x1 M4x25
D4	 x16 ø 17	L50	 x3	A121		x6 meln. ø 3x15
E4	 x1 17x182mm	A15	 x4 ø 5,8x11	A8		x2 M4x12
N3	 x2 Ø7x1,5	H20	 x2 ø 8x50	A133		x2 ø 4,5x60

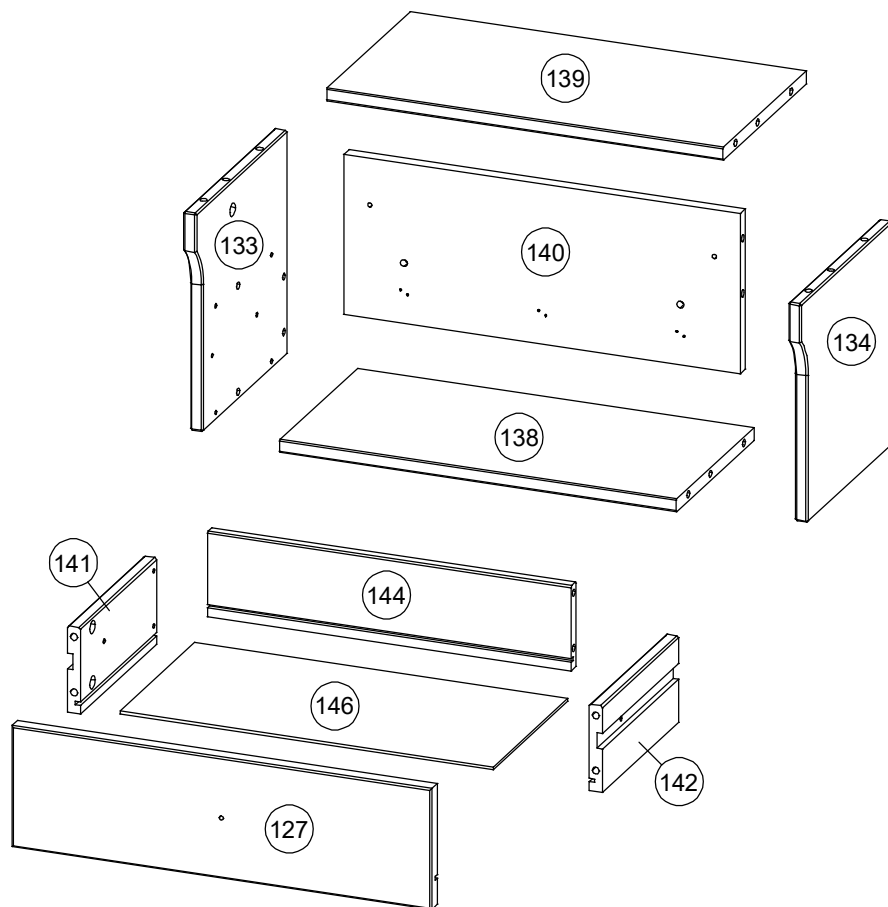

Teil Nr. Pièces Nr. Pieces Nr. Часть Ном. Kawalek Nr. Parça No Kusù Nr. Kusov Nr. Pezzi Nr. Nr piese. Darab száma. Stukken Nr. Kārtas Nr.	Anzahl Quantité Quantity Количество Ilość Miktar Množství Množstvo Quantità Cantitatea Mennyiség Hoeveelheid Skaitis	Kasten Nr. Colli Nr. Colli Nr. Коробка Ном. Polu Nr. Kutusu Nr. Kolonka Č. Počet balení Colli Nr. Nu pachete Colli száma. Colli Nr. Kastes Nr.	Maß, mm Dimensions, mm Dimensions, mm Размеры, mm Wymiary, mm Boyutlar, mm Rozměry, mm Rozmery, mm Dimensioni, mm Dimensiuni, mm Méterek, mm Afmetingen, mm Izmēri, mm	✓
127	1	1 / 1	486 x 140 x 18	
133	1	1 / 1	260 x 260 x 15	
134	1	1 / 1	260 x 260 x 15	
138	1	1 / 1	459 x 223 x 15	
139	1	1 / 1	459 x 239 x 15	
140	1	1 / 1	459 x 185 x 15	
141	1	1 / 1	218 x 100 x 18	
142	1	1 / 1	218 x 100 x 18	
144	1	1 / 1	421 x 98 x 15	
146	1	1 / 1	432 x 214 x 3	

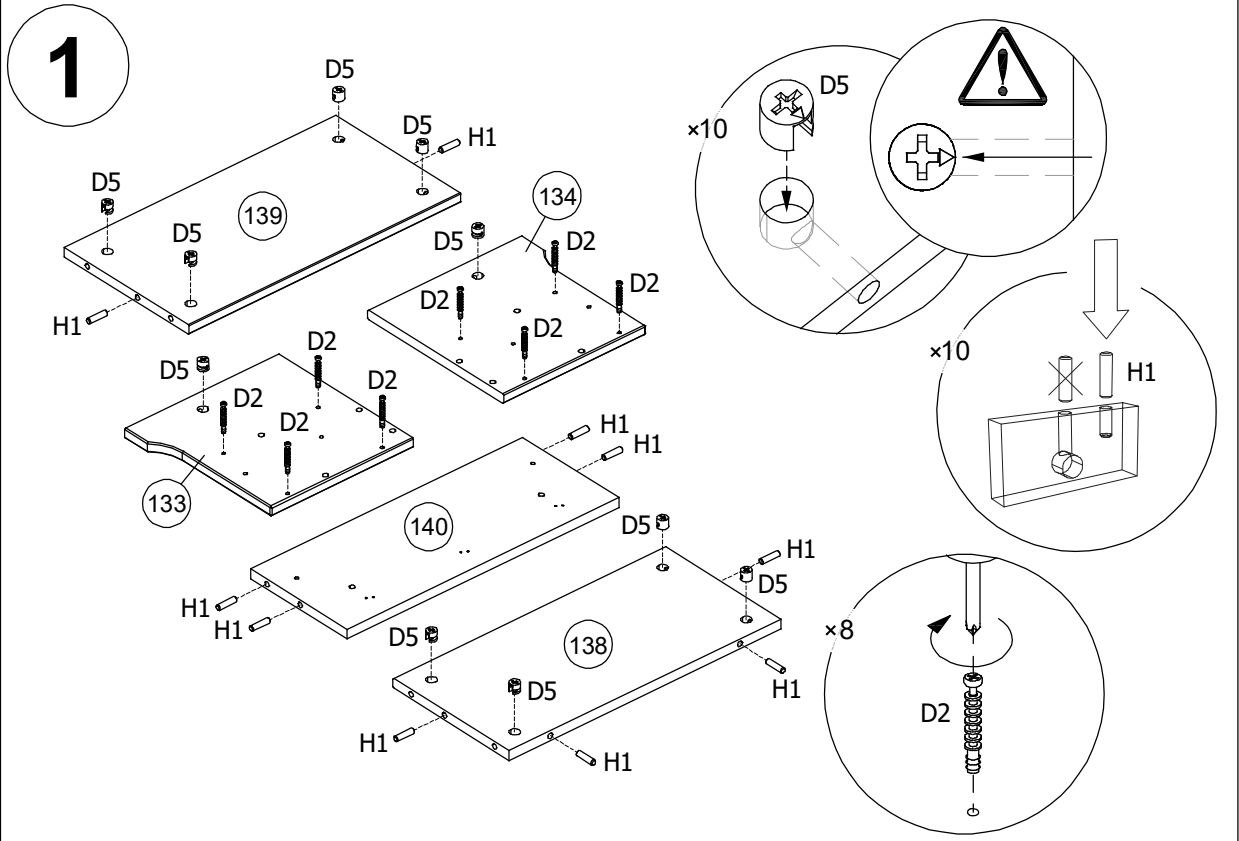

idp12459-1 idp12459-2

H1		x10 ø 8x30	D2		x8 ø 5/11x34	D5		x10 ø 15x12,5
----	---	---------------	----	---	-----------------	----	---	------------------

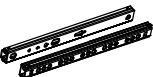

L50		x3	E4		x1 17x182mm	A15		x4 ø 5,8x11
A121		x6 3x15						

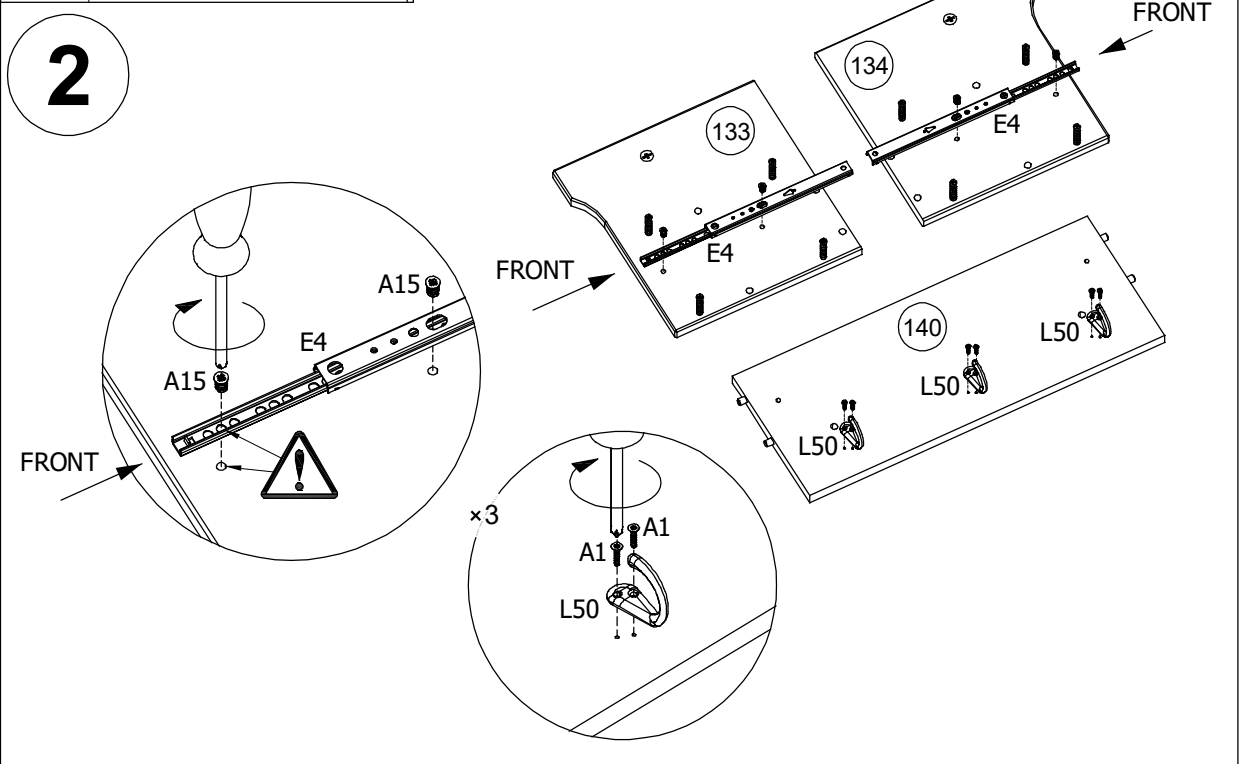

idp12459-1 idp12459-2



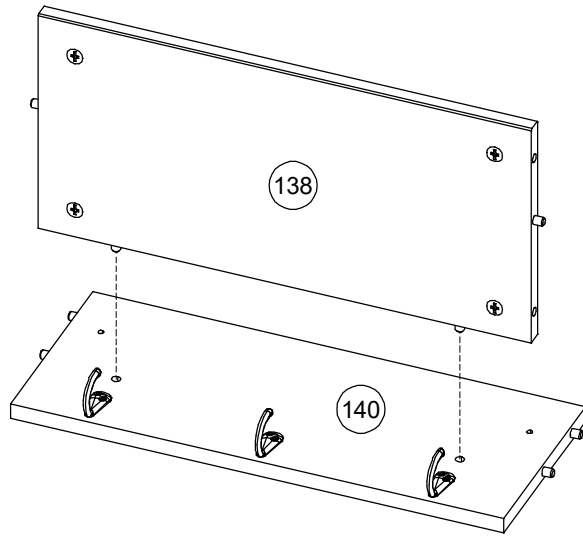

3

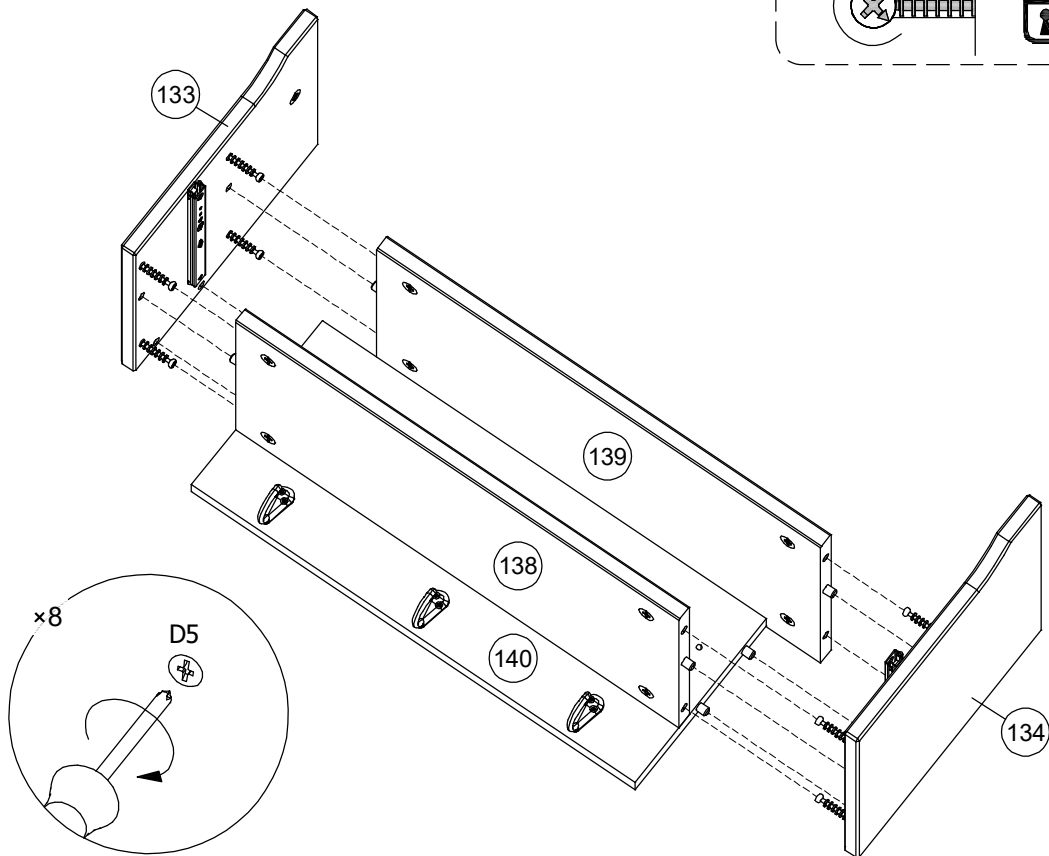
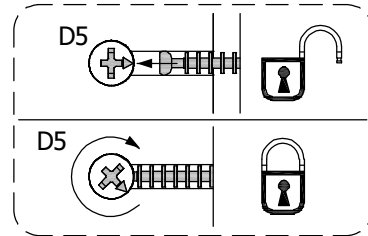
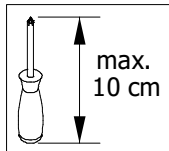

4



idp12459-1 idp12459-2

D317	 x8 ø 15x12	D2	 x8 ø 5/11x34	N3	 x2 Ø7x1,5
B122	 x1	A16	 x1 M4x25		

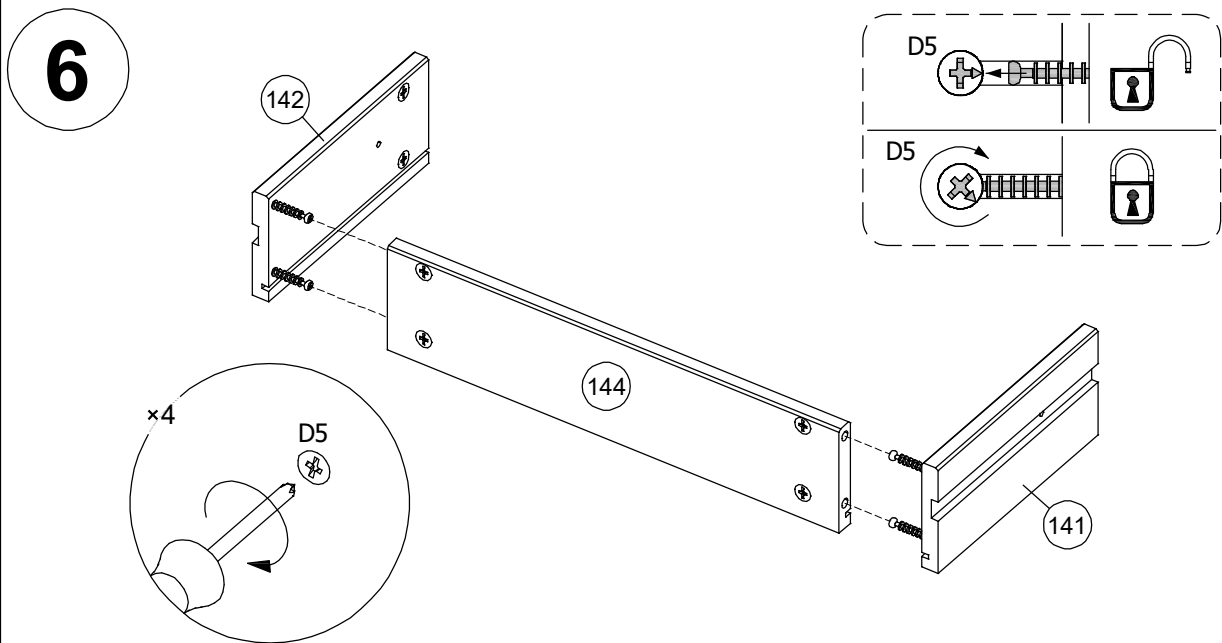
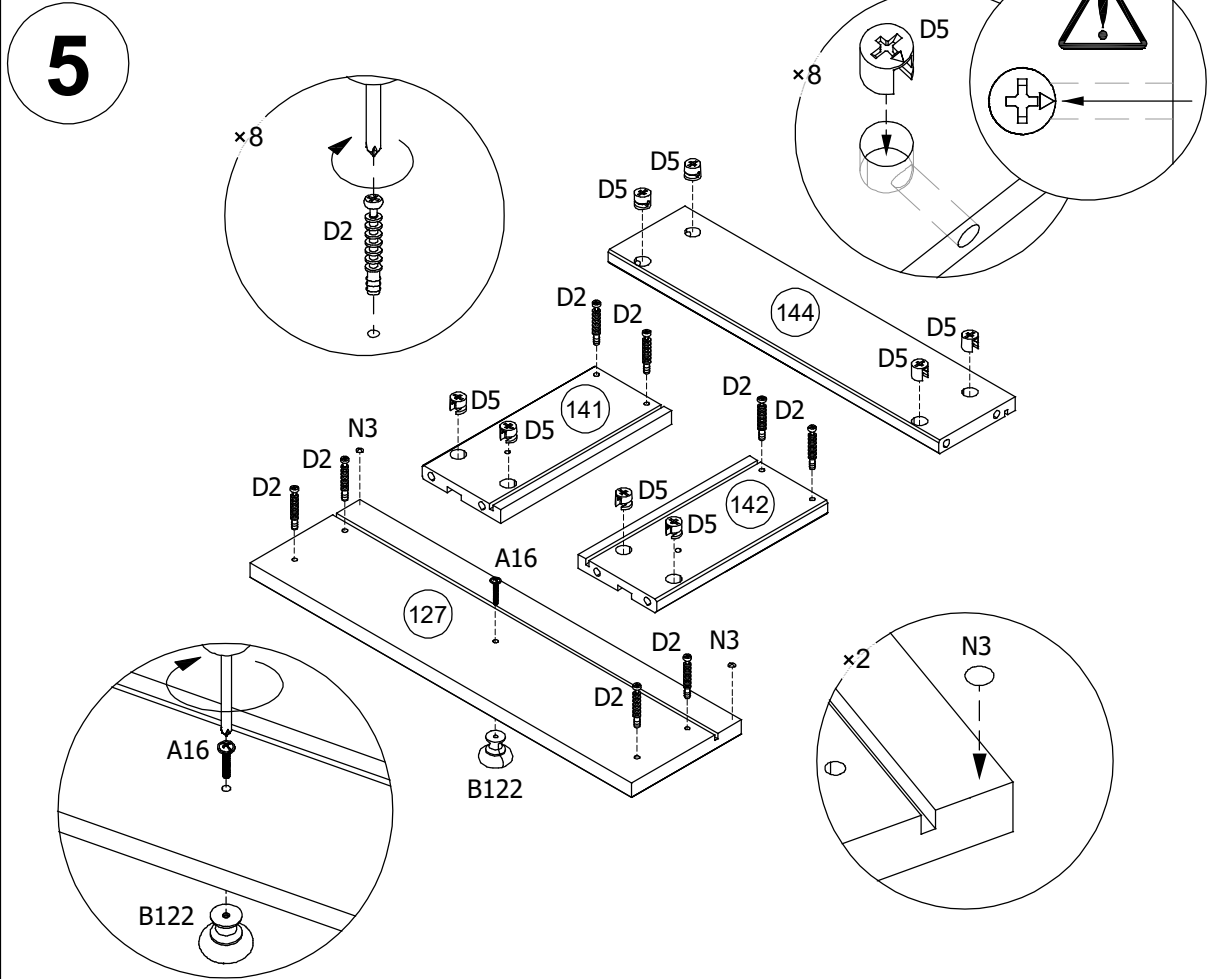

idp12459-1 idp12459-2

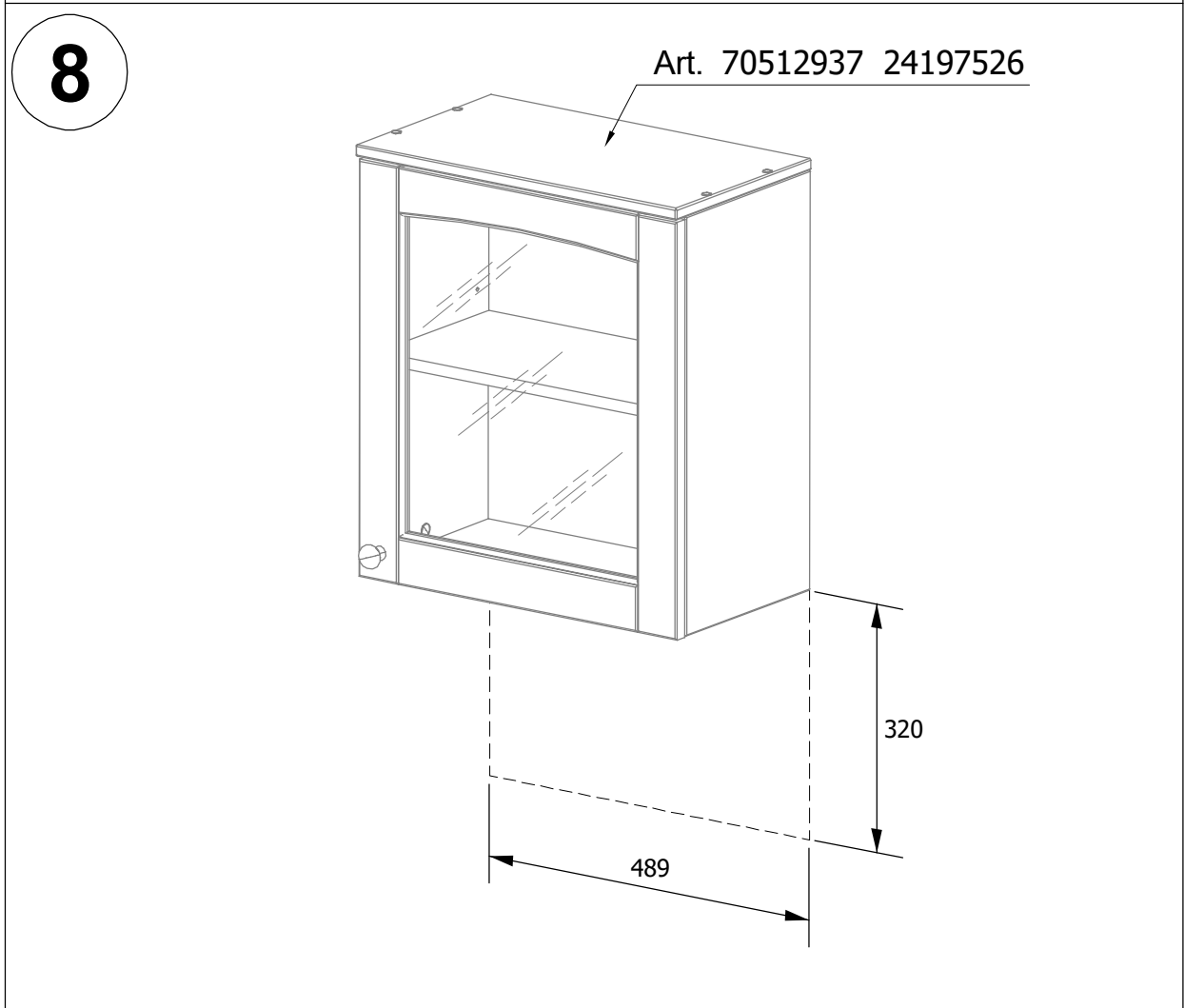
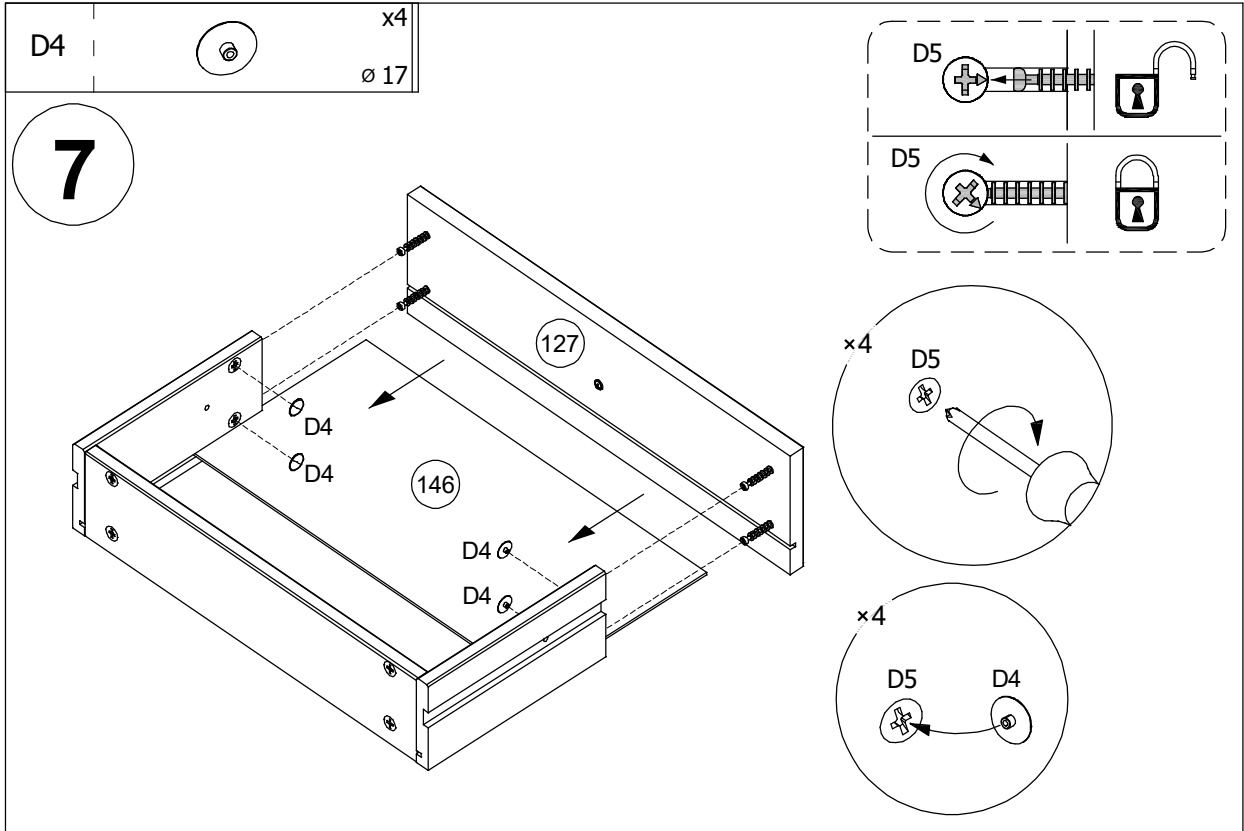

idp12459-1 idp12459-2

9

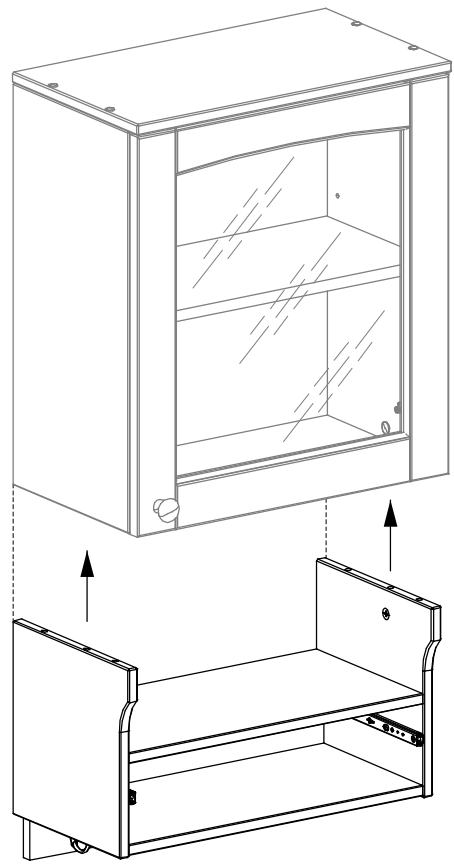
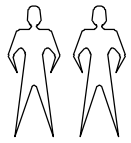

10

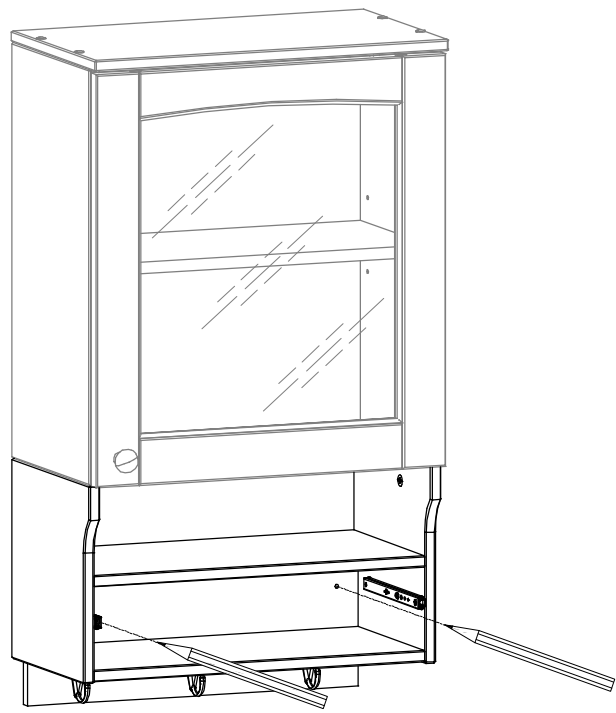
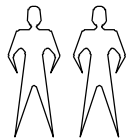

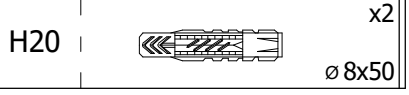
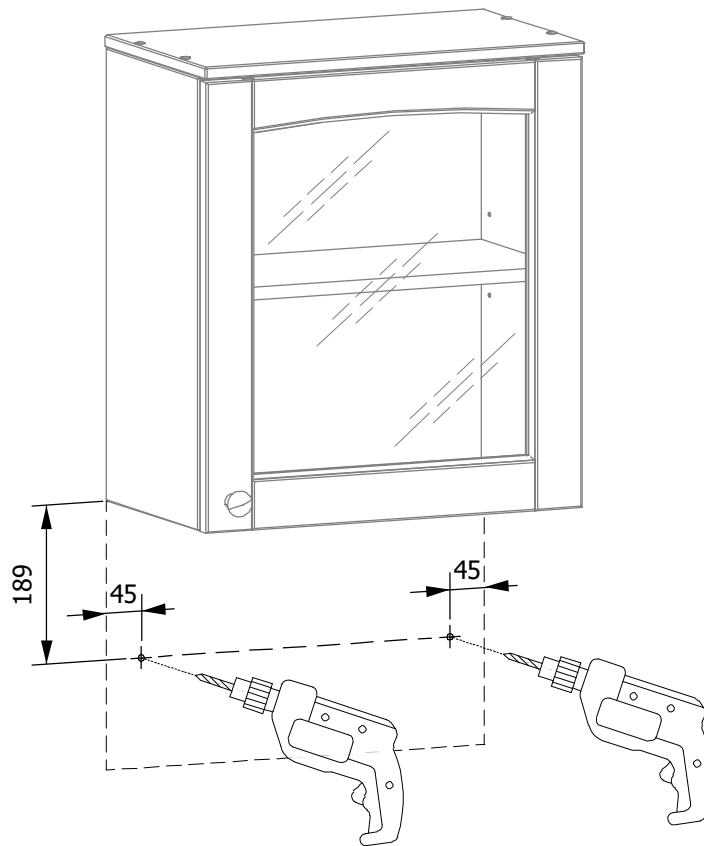
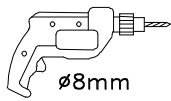

idp12459-1 idp12459-2

11

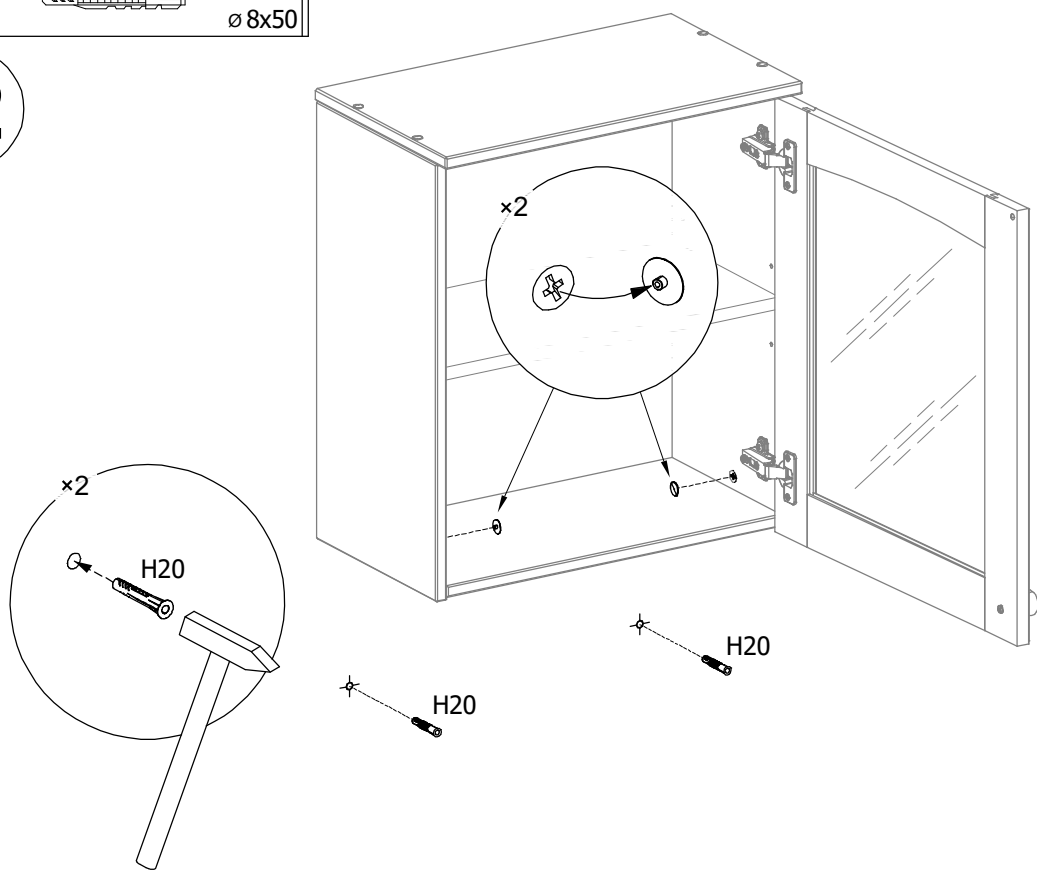

12

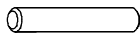

D59		x2	H3		x4
		L=34/34			Ø8x50

13

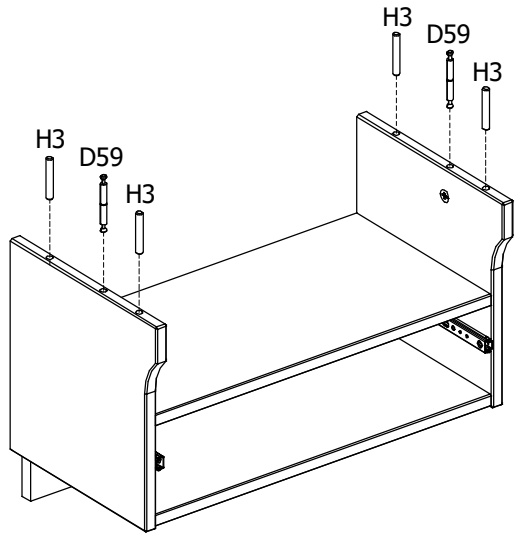

14

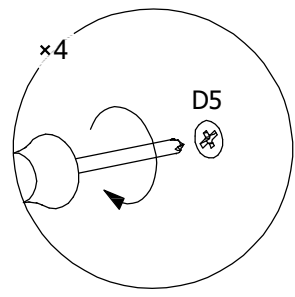
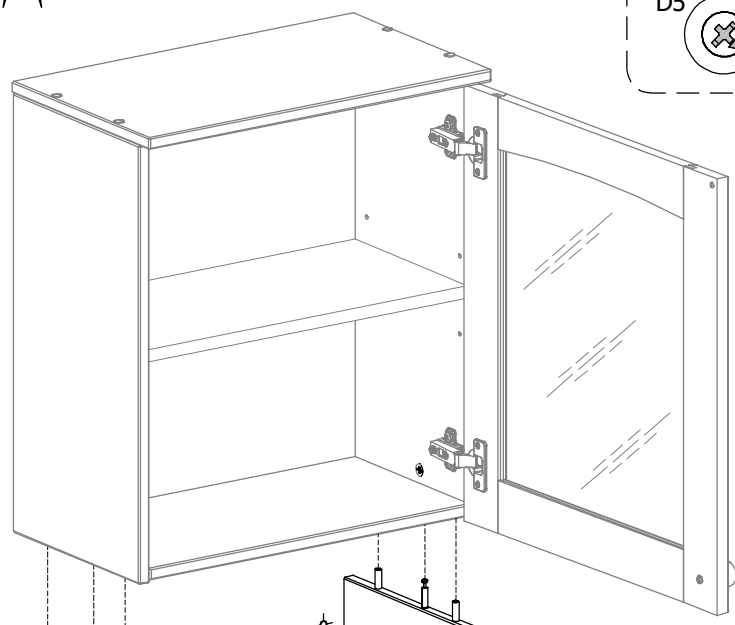
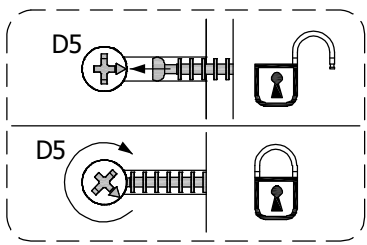
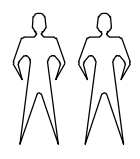

idp12459-1 idp12459-2

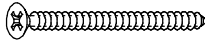
A133 |  x2
ø 4,5x60

15

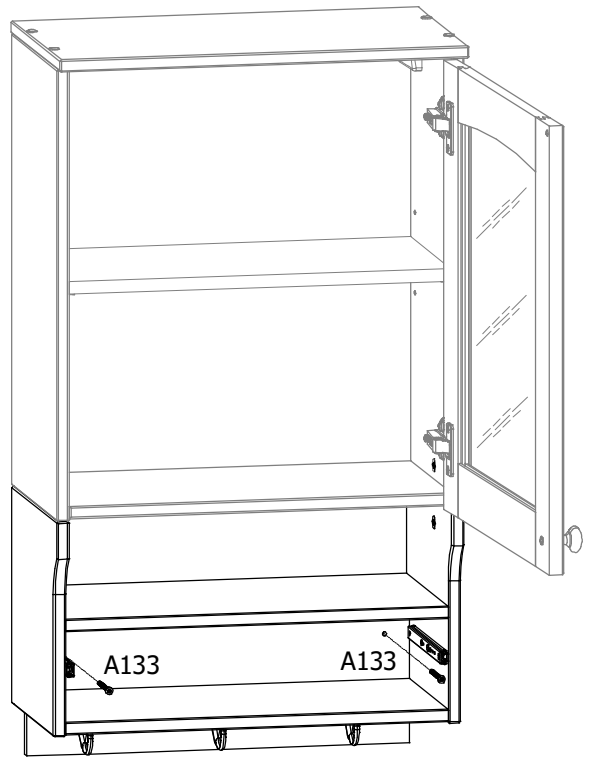
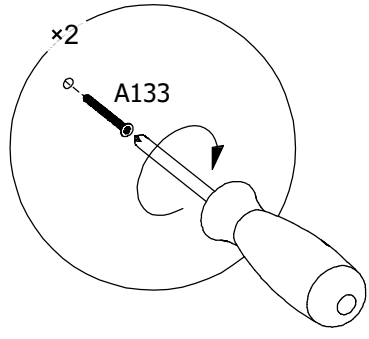

D4 |  x12
ø 17

16

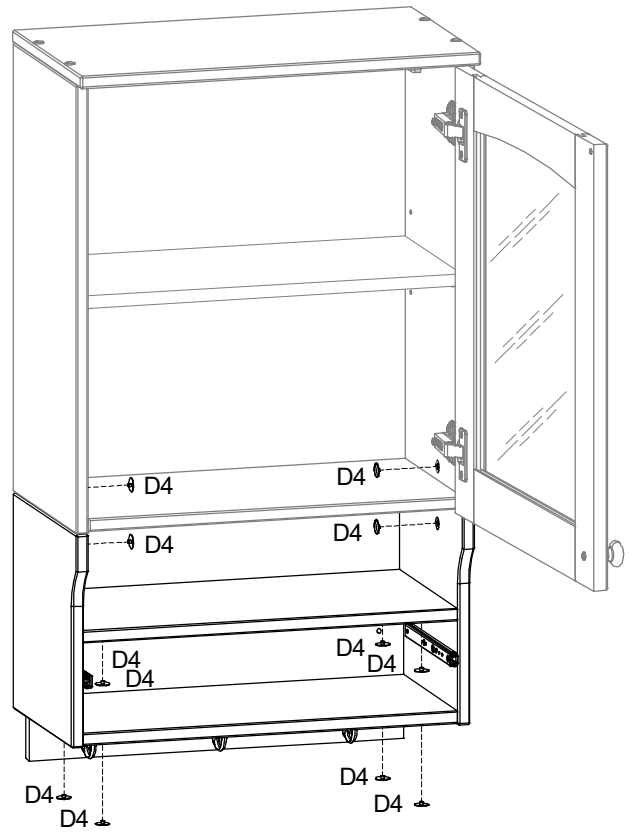
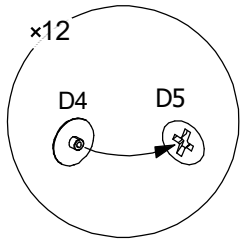

A8



x2

M4x12

17

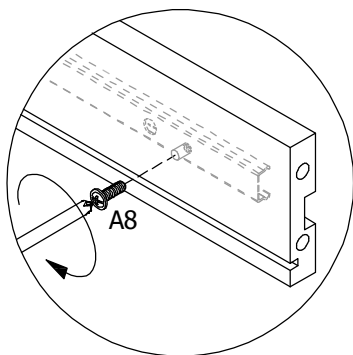
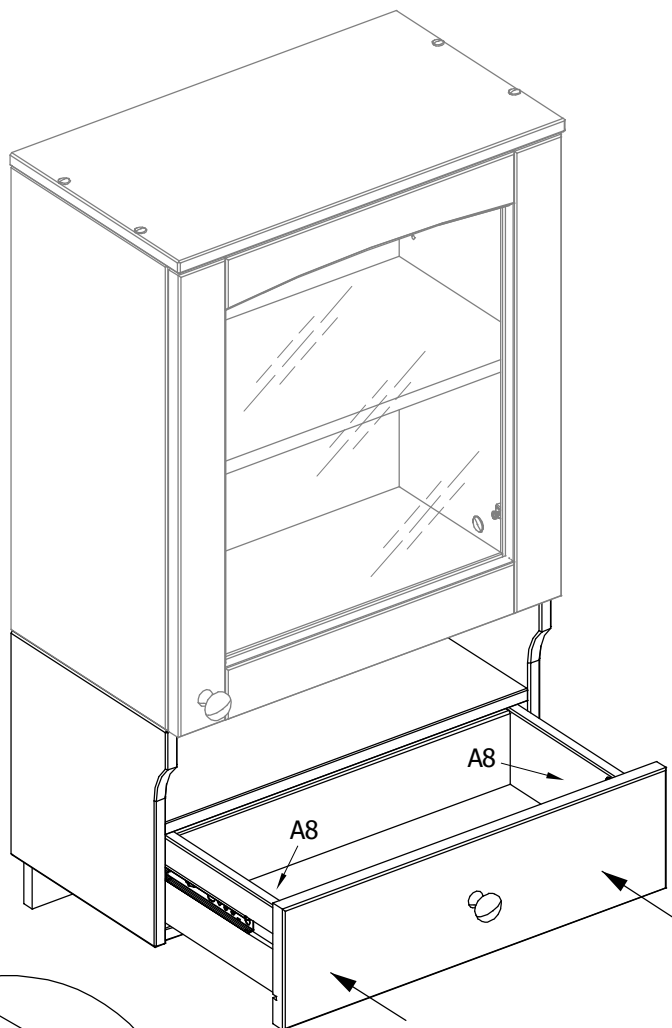

idp12459-1 idp12459-2

H20 

A133 
 ø4,5x60

 ø8mm

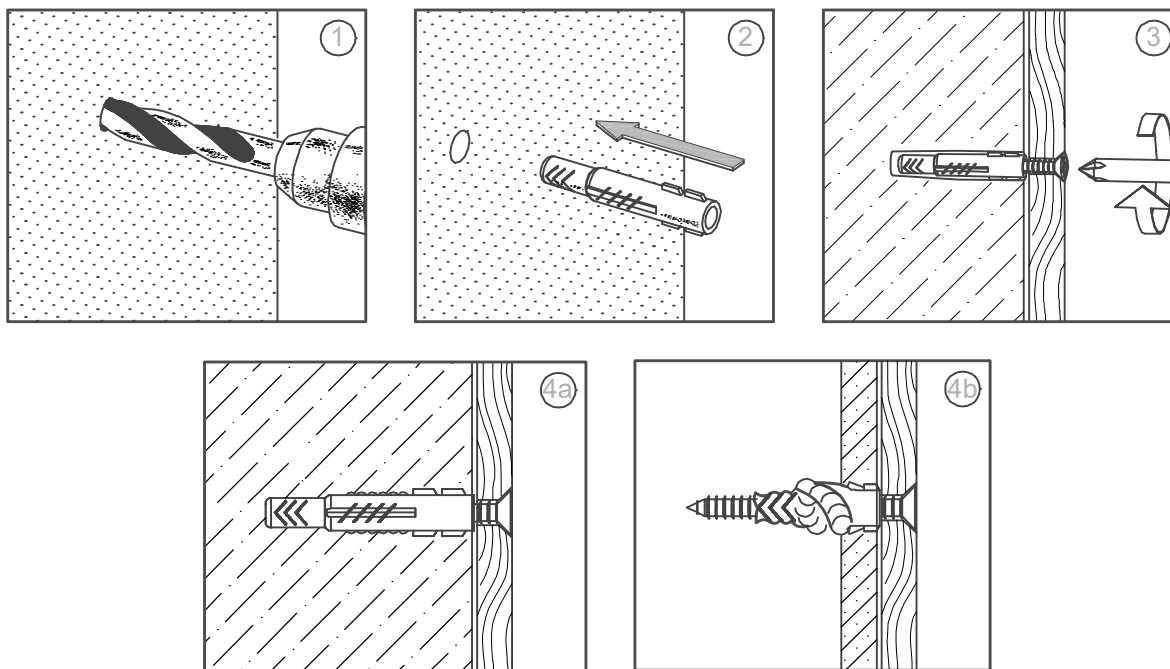

- D** **Achtung:** Die Befestigung des Möbelstückes an der Wand muss von einer fachkundigen Person vorgenommen werden, da für die Montage an die Wand angepasste Dübel erforderlich sind.
- GB** **Attention:** A qualified professional is required when mounting furniture to the wall since dowels corresponding to the wall are required for this.
- FR** **Attention :** La fixation du meuble contre le mur doit être effectuée par une personne compétente car, pour le montage mural, il faut utiliser des chevilles adaptées.
- IT** **Attenzione:** Il fissaggio del mobile alla parete deve essere eseguito da persone esperte, dato che occorrono tasselli adeguati.
- NL** **Opgelet:** een vakkundige persoon dient het meubelstuk aan de muur te bevestigen; voor de montage aan de muur zijn immers aangepaste pluggen vereist.
- PL** **Uwaga:** Mocowanie mebla do ściany mogą przeprowadzić wyłącznie wykwalifikowane osoby, z uwagi na zastosowanie odpowiednio dopasowanych kołków do rodzaju ściany.
- CZ** **Pozor:** Montáž nábytku na stěnu musí provést odborník, protože k montáži na stěnu jsou zapotřebí upravené hmoždinky.
- SK** **Pozor:** Upevnenie nábytku na stenu musí vykonať odborník, nakoľko sú pre montáž na stenu potrebné vhodné hmoždinky.
- HU** **Figyelem:** A bútorelemek falra rögzítését szakembernek kell végeznie, mert a rögzítéshez megfelelő tiplit kell használni.
- RO** **Atenție:** Fixarea la perete a piesei de mobilier se realizează numai de către personal competent, deoarece montajul de perete necesită dibluri adecvate.
- TR** **Dikkat:** Mobilya parçasının duvara sabitlenmesi, duvar montajı için özel uyarlanmış dübeller gerektirdiğinden bu iş sadece bu konuda uzman bir kişi tarafından gerçekleştirilmelidir.
- RU** **Внимание:** Поскольку для монтажа на стене необходимо использовать специальные дюбели, мебель должна быть закреплена на стене квалифицированным персоналом.
- LV** **Uzmanību:** Mēbeles montāžai pie sienas paredzēts izmantot speciālus dībeļus. Ietecams šo darbu veikt kvalificētam darbiniekam.

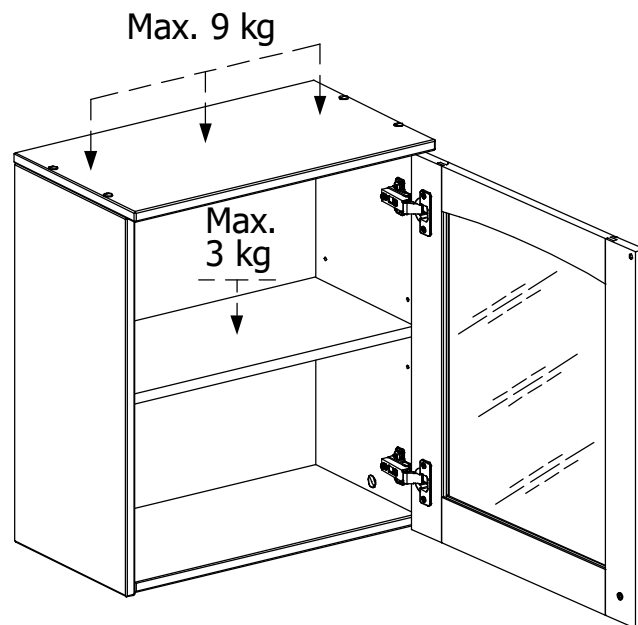
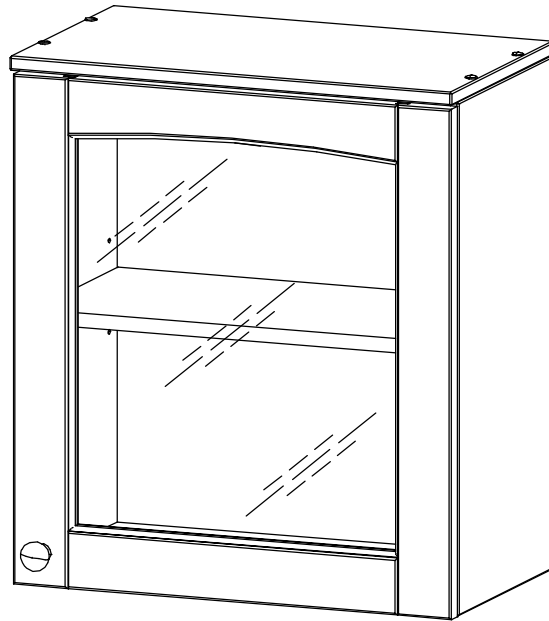
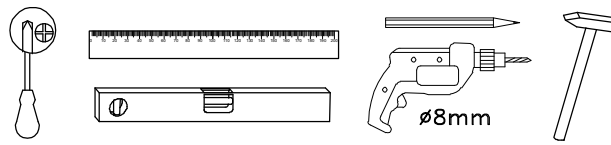
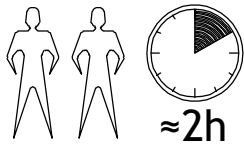

idp68239-1 idp68239-2

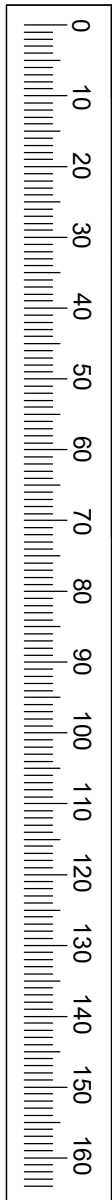









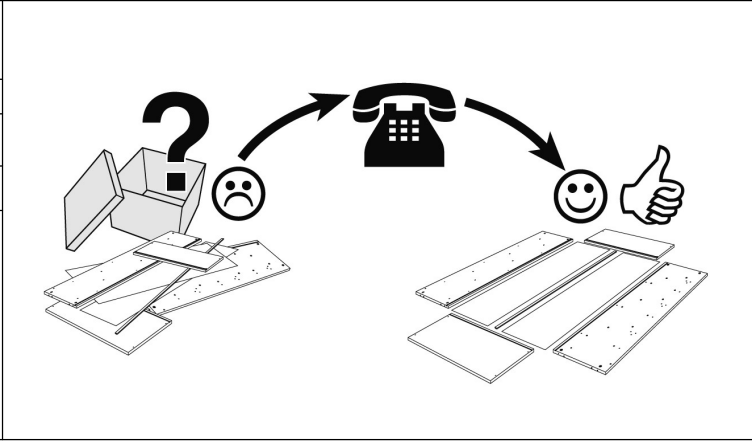
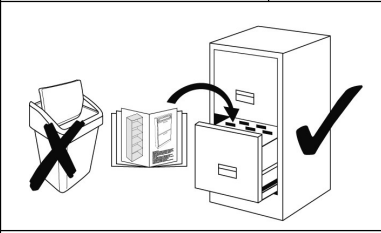







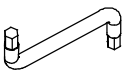

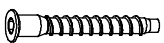

Service • Assistenza • Dienstverlening • Serwis
 Servis • Szerviz • Сервисная служба

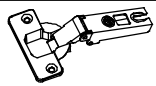
Name • Nom • Nome • Naam
 Nazwa • Jméno • Názov • Név
 Denumire • Isim • Название

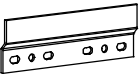
Nr • No • N • Номер • Č • Sz

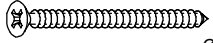
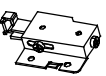
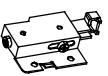
Tur • Ture • Тір • Тірус • Тіро
 Тип

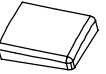
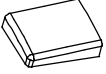



		D5		x6 ø 15x12,5	H1		x8 ø 8x30	
D1		x4 ø 5	D4		x6 ø 17	D2		x4 ø 5/11x34
A5		x1 SW4	D24		x4 ø 13	A27		x4 ø 7x50
N3		x1 ø 7x1,5	B122		x1	A16		x1 M4x25
G101		x2 2mm	G98		x2 ø 35	A1		x4 ø 3,5x15
D48		x2	H20		x4 ø 8x50	A133		x4 ø 4,5x60
D141		x1 Right	D142		x1 Left	A108		x4 ø 4x15
D144		x1 Right	D143		x1 Left	D36		x6 15x15x10

idp68239-1 idp68239-2

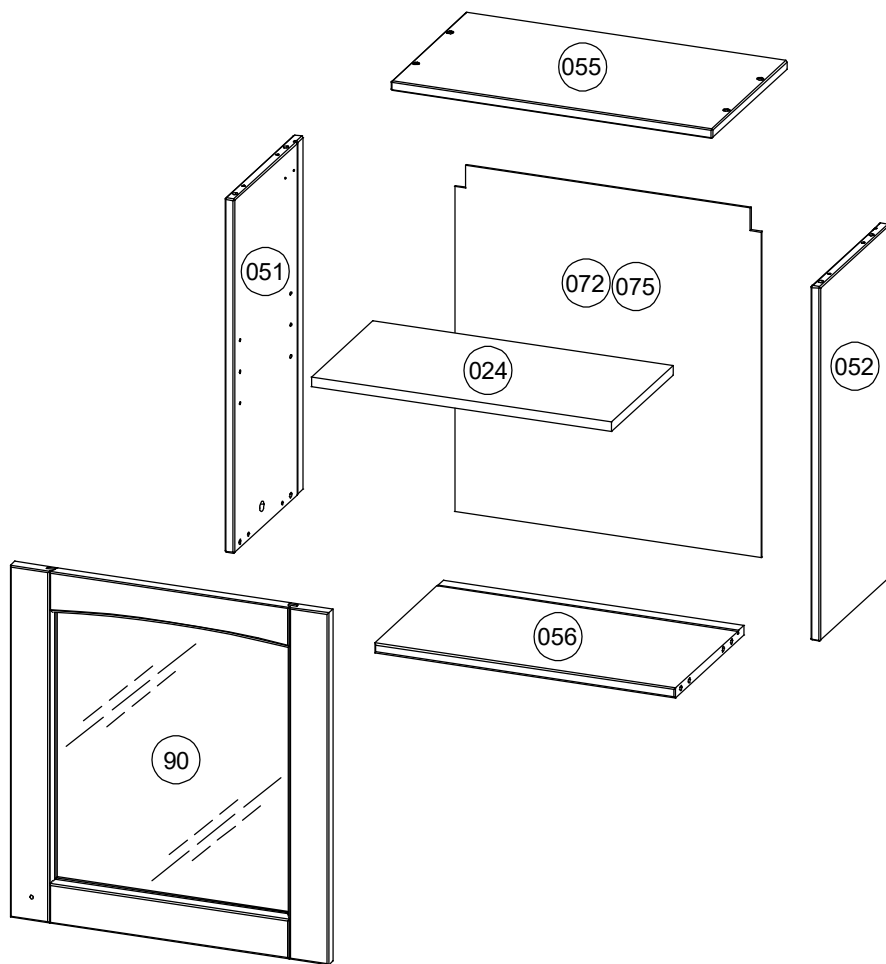

Teil Nr. Pièces Nr. Pieces Nr. Часть Ном. Kawalek Nr. Parça No Kusù Nr. Kusov Nr. Pezzi Nr. Nr piese. Darab száma. Stukken Nr. Kārtas Nr.	Anzahl Quantité Quantity Количество Ilość Miktar Množství Množstvo Quantità Cantitatea Mennyiség Hoeveelheid Skaitis	Kasten Nr. Colli Nr. Colli Nr. Коробка Ном. Polu Nr. Kutusu Nr. Kolonka Č. Počet balení Colli Nr. Nu pachete Colli száma. Colli Nr. Kastes Nr.	Maß, mm Dimensions, mm Dimensions, mm Размеры, mm Wymiary, mm Boyutlar, mm Rozměry, mm Rozmery, mm Dimensioni, mm Dimensiuni, mm Méterek, mm Afmetingen, mm Izmēri, mm	✓
051	1	1 / 1	540 x 260 x 15	
052	1	1 / 1	540 x 260 x 15	
055	1	1 / 1	491 x 282 x 15	
056	1	1 / 1	459 x 260 x 15	
024	1	1 / 1	458 x 232 x 15	
72 (75)	1	1 / 1	530 x 468 x 3	
90	1	1 / 1	536 x 486 x 18	

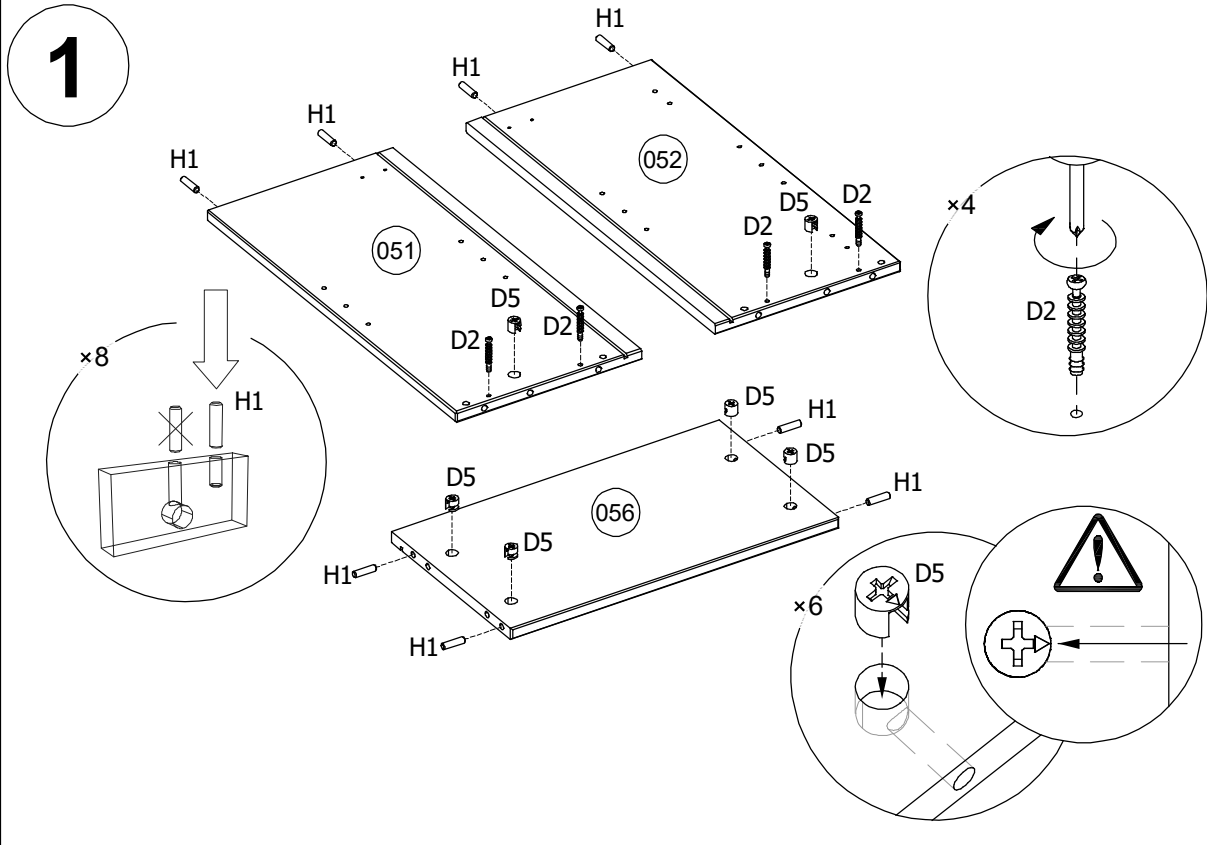

idp68239-1 idp68239-2

H1		x8 ø 8x30	D2		x4 ø 5/11x34	D5		x6 ø 15x12,5
----	---	--------------	----	---	-----------------	----	---	-----------------

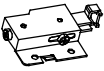
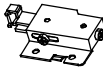

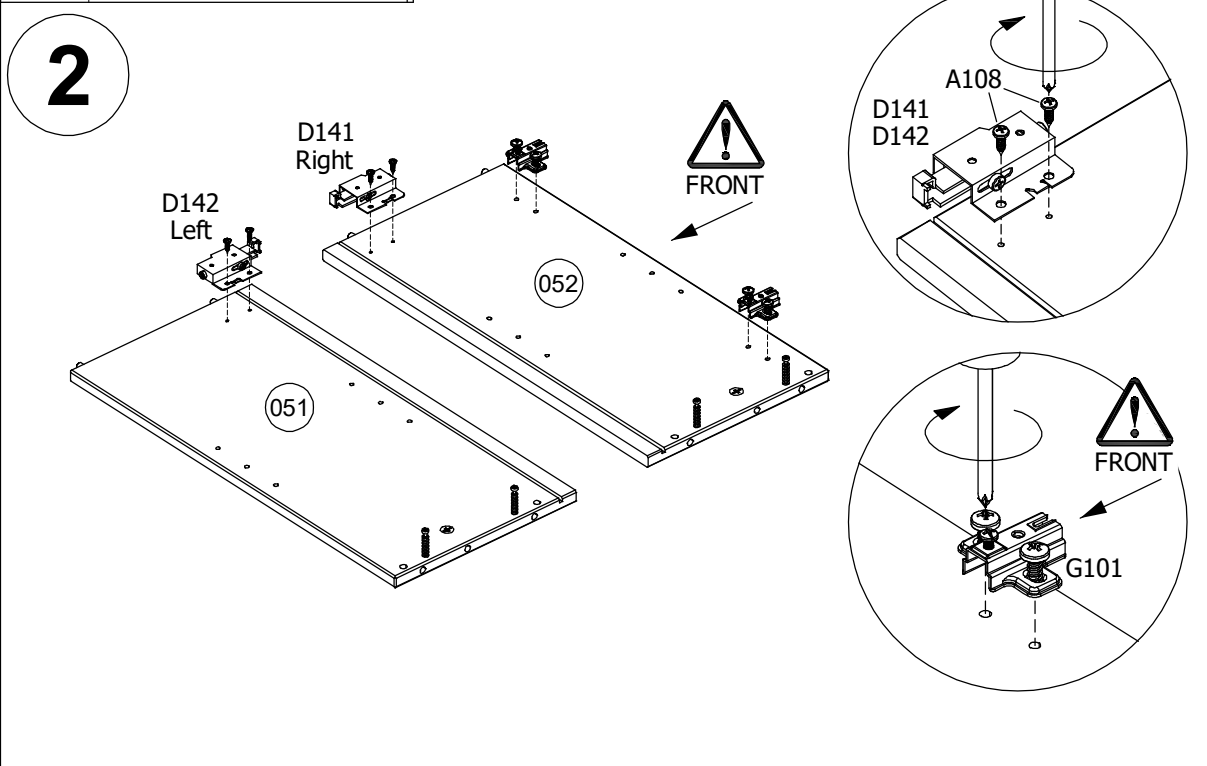

D142		x1 Left	D141		x1 Right	A108		x4 ø 4x15
G101		x2 2mm						

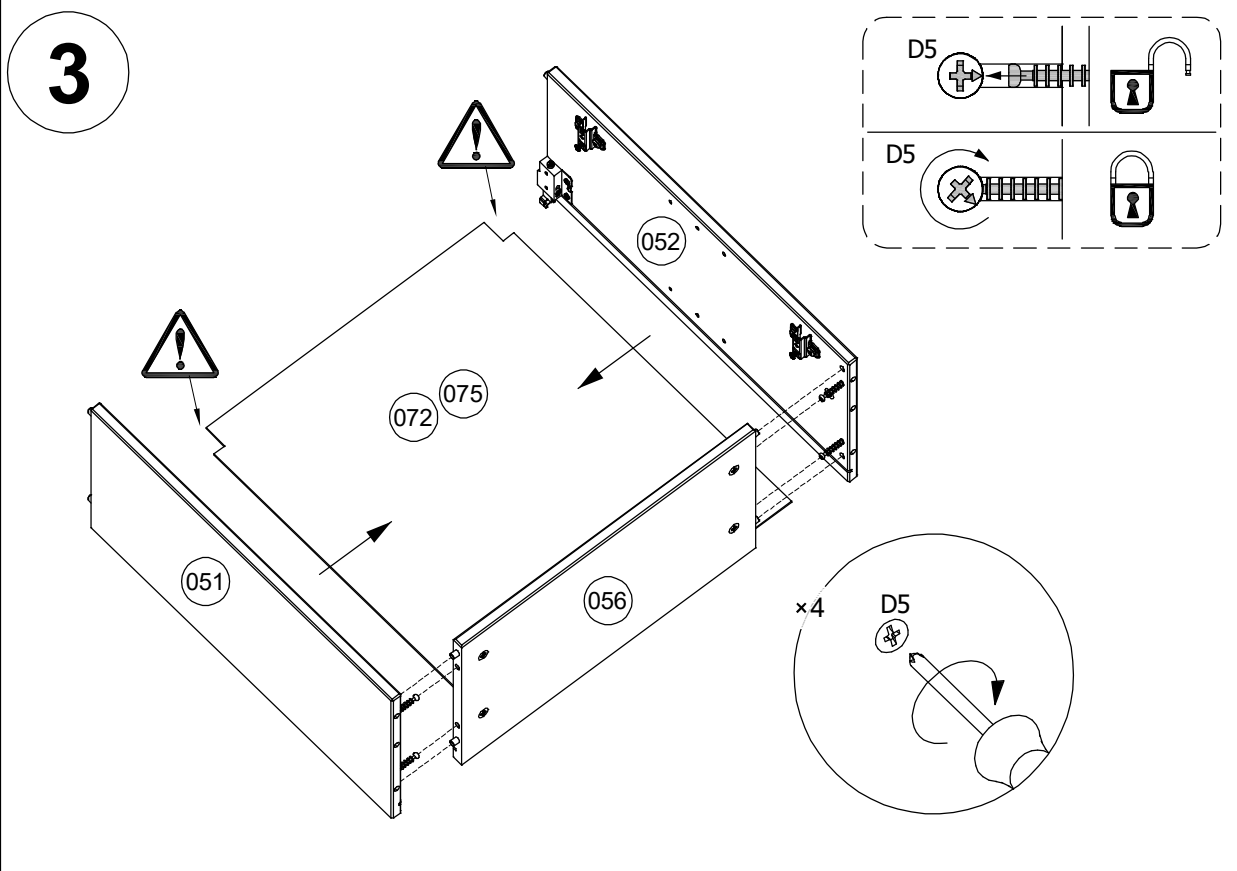

idp68239-1 idp68239-2



A27		x4	A5		x1	D24		x4
		ø7x50			SW4			Ø13

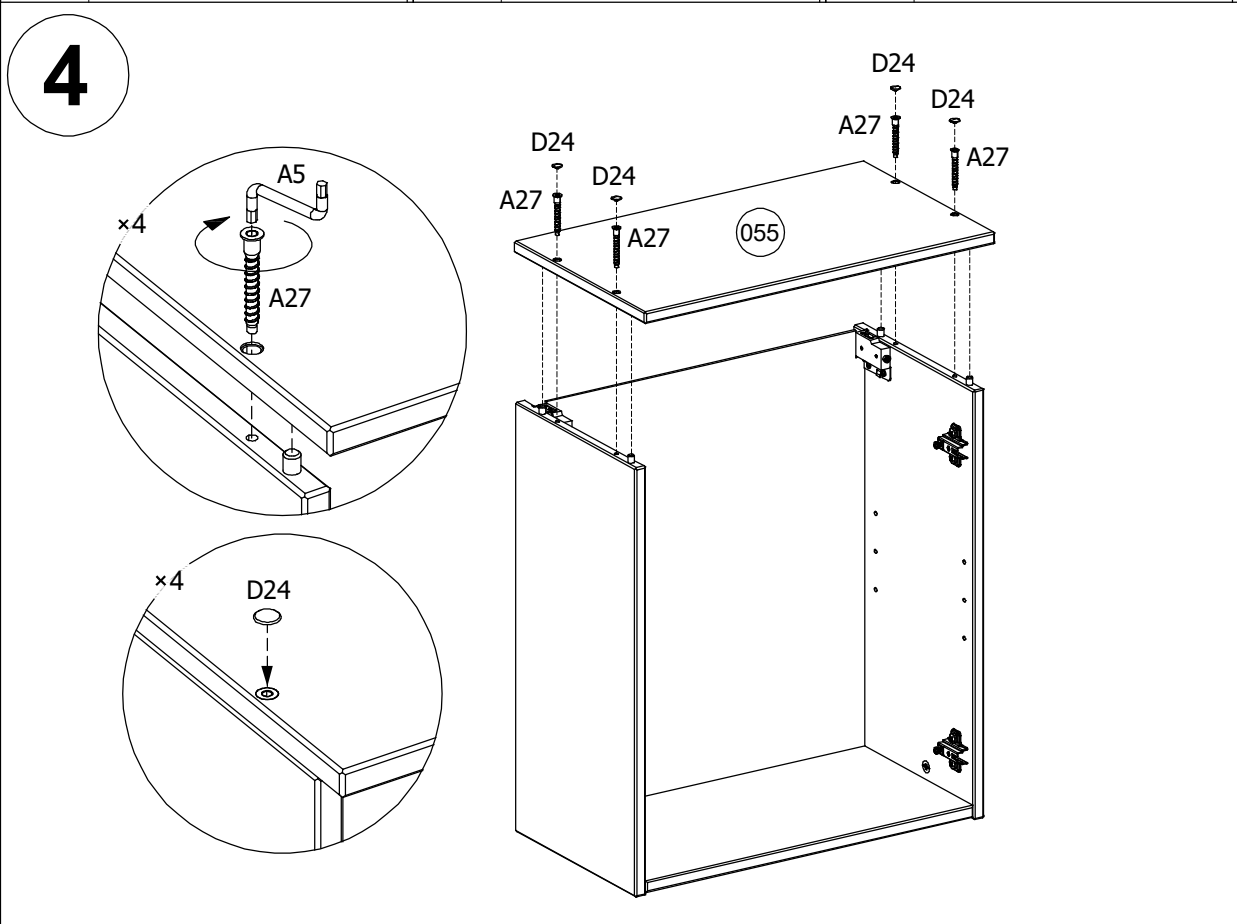

idp68239-1 idp68239-2

D36 x6
15x15x10

5

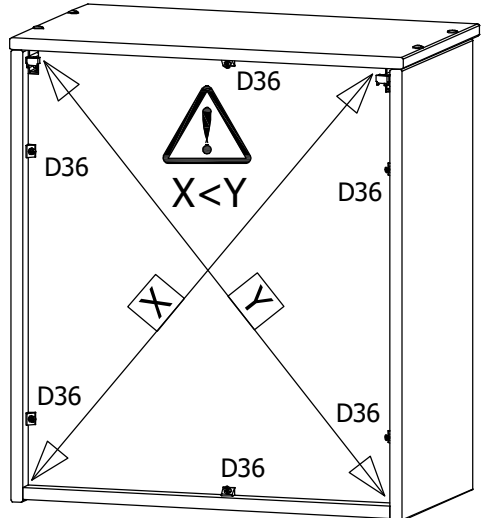
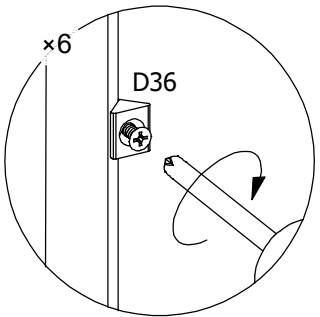
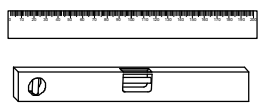

D48 x2

H20 x4
ø 8x50

A133 x4
ø4,5x60

6

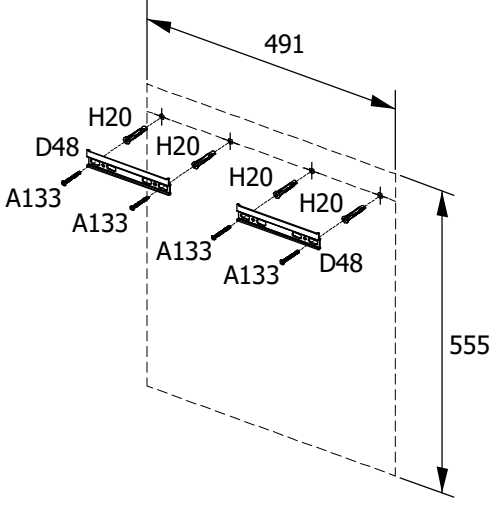
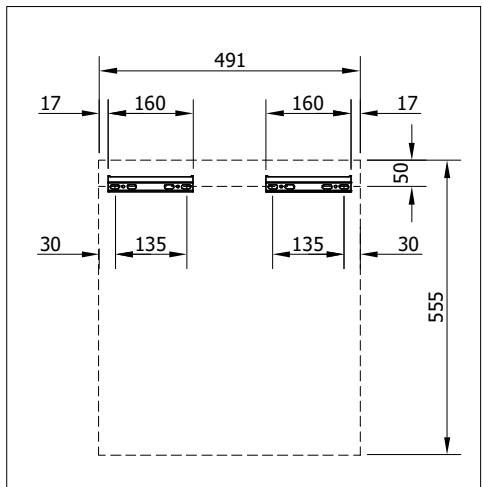
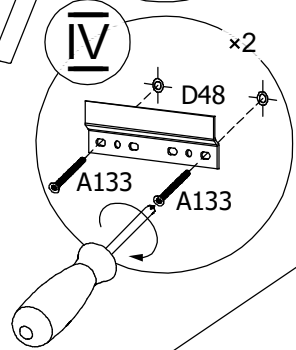
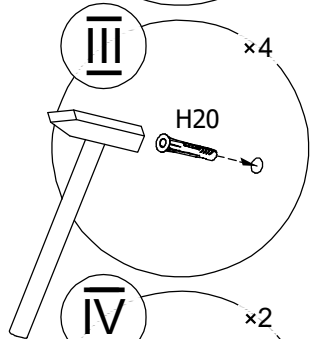
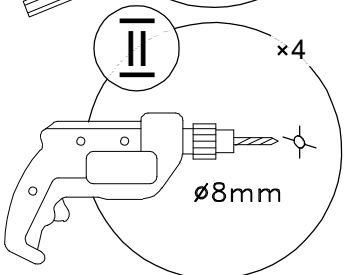
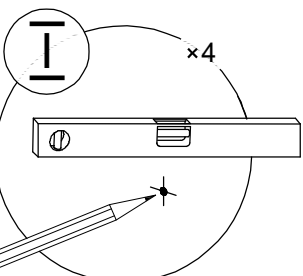

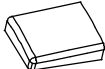
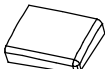

D143		x1	D144		x1
		Left			Right

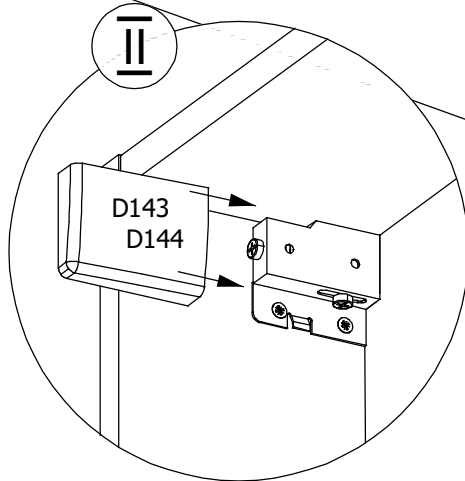
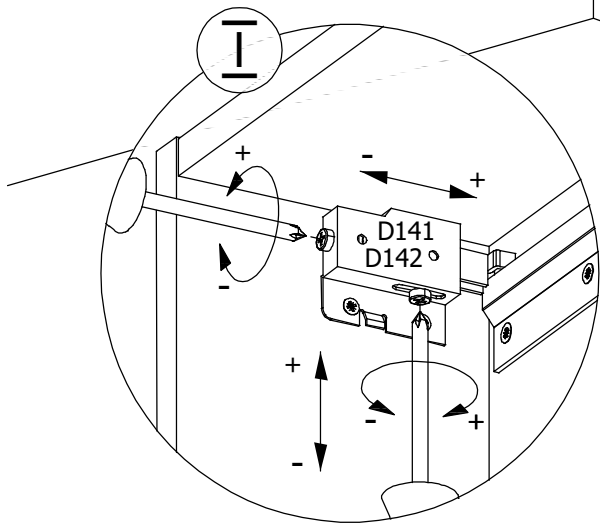
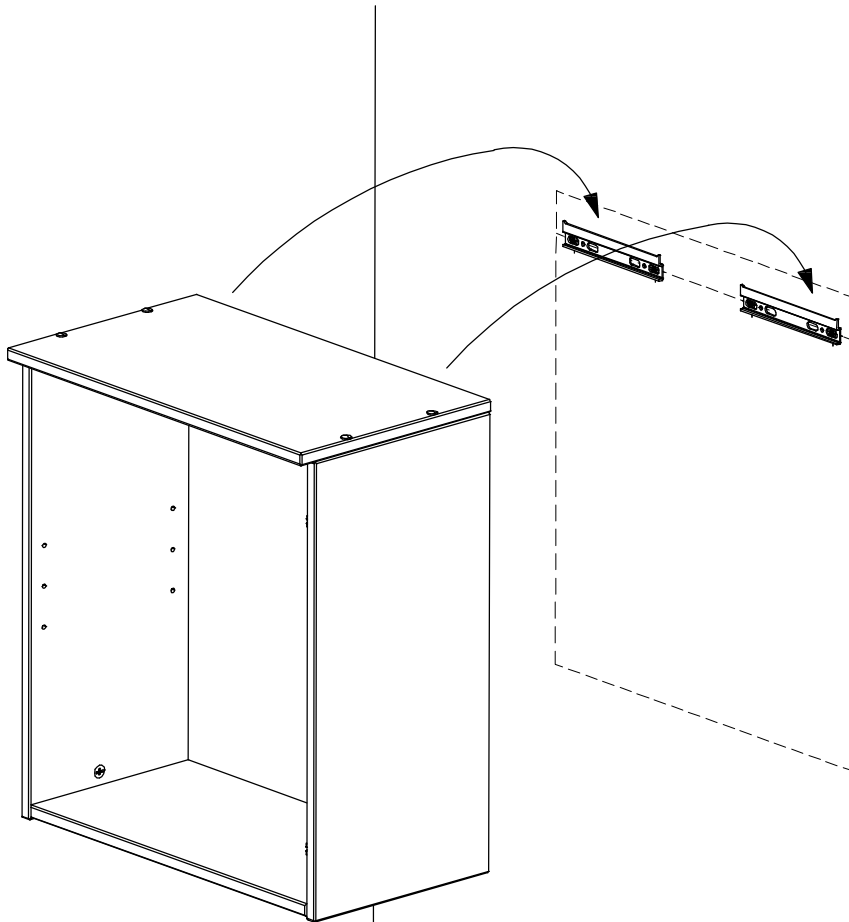
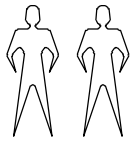
7



idp68239-1 idp68239-2

D1		x4 ø5	D4		x6 ø17
----	---	----------	----	---	-----------



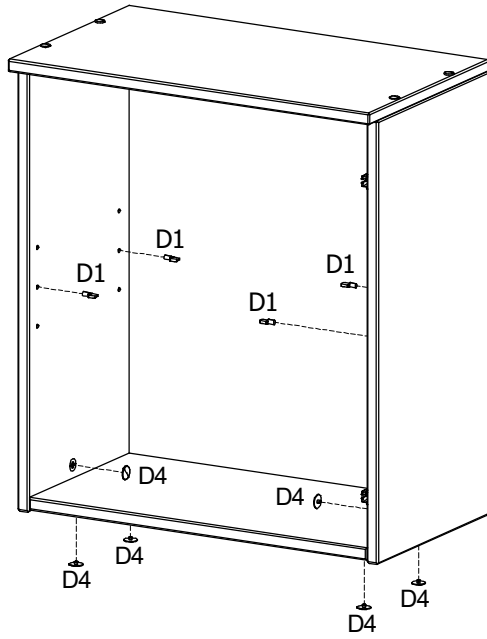
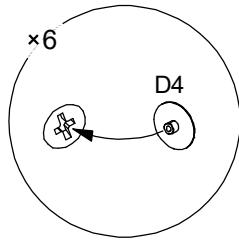
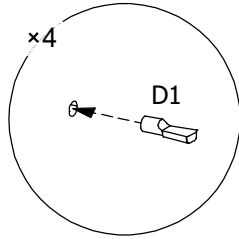

8

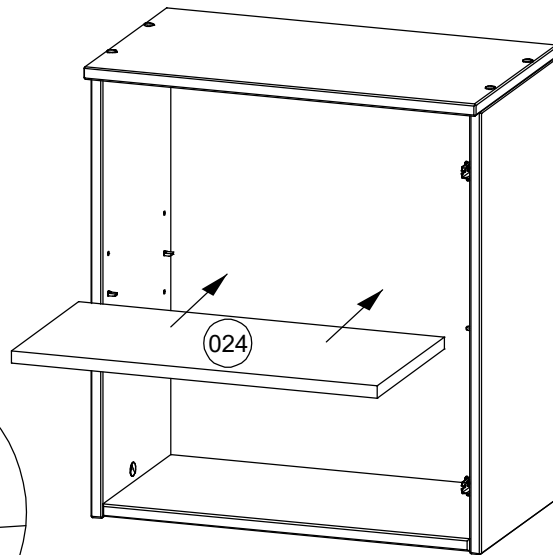
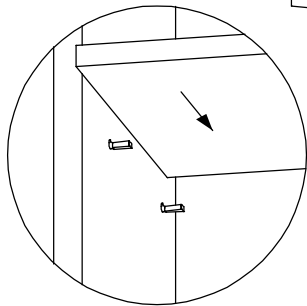

9

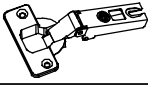

idp68239-1 idp68239-2

G98		x2	A1		x4	N3		x1
B122		x1	A16		x1			
					Ø 3,5x15			Ø7x1,5
					M4x25			

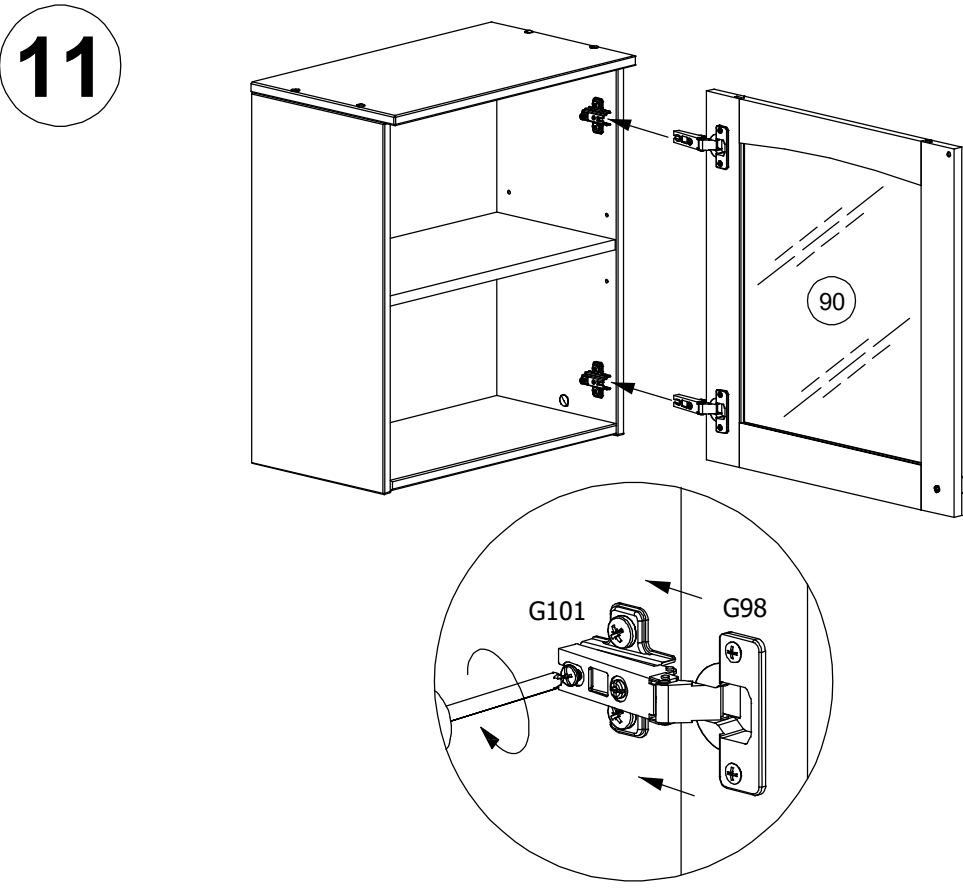
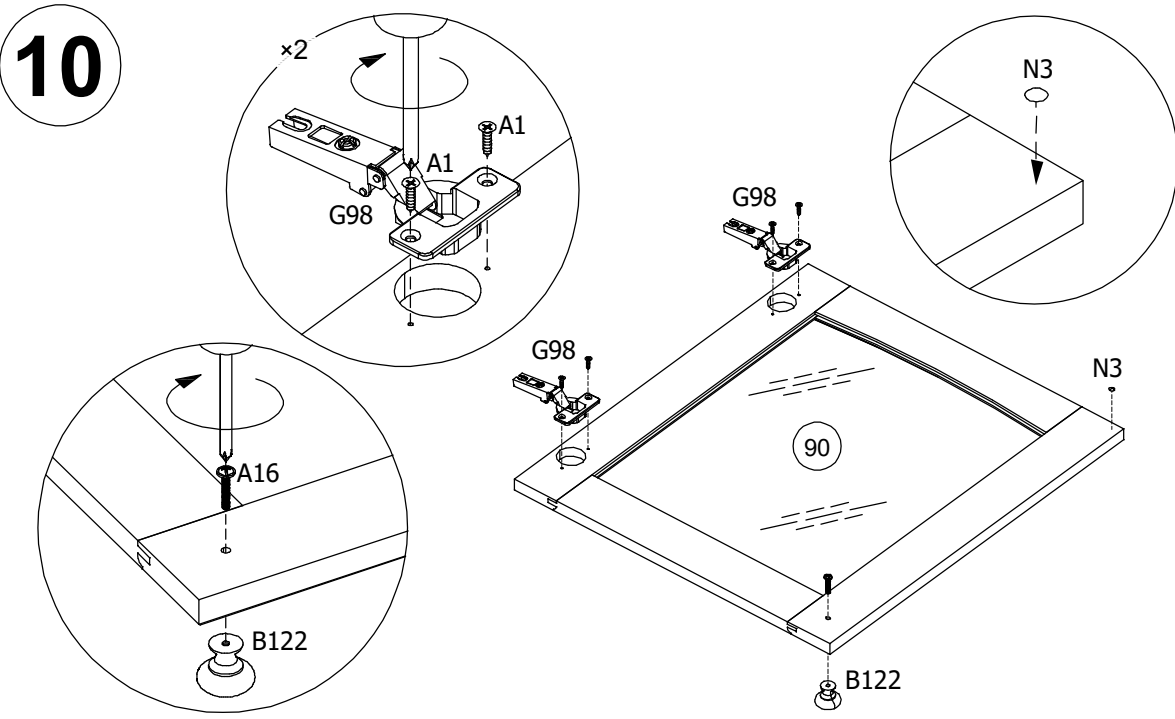

idp68239-1 idp68239-2

H20 

A133 
 ø4,5x60

 ø8mm

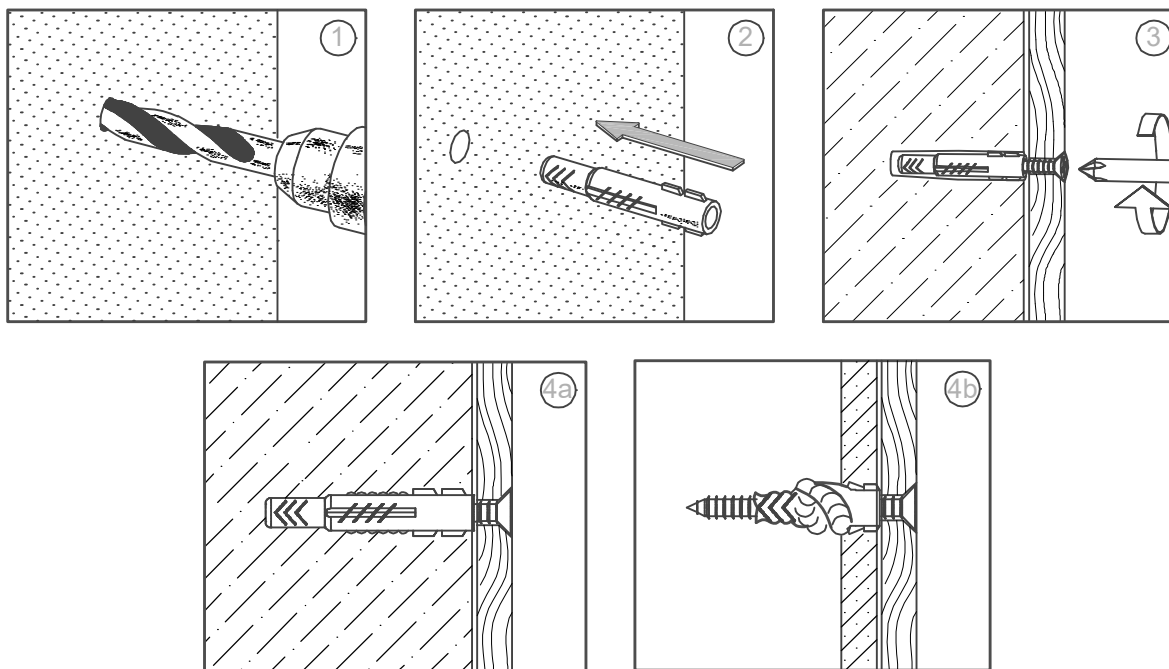

- D** **Achtung:** Die Befestigung des Möbelstückes an der Wand muss von einer fachkundigen Person vorgenommen werden, da für die Montage an die Wand angepasste Dübel erforderlich sind.
- GB** **Attention:** A qualified professional is required when mounting furniture to the wall since dowels corresponding to the wall are required for this.
- FR** **Attention :** La fixation du meuble contre le mur doit être effectuée par une personne compétente car, pour le montage mural, il faut utiliser des chevilles adaptées.
- IT** **Attenzione:** Il fissaggio del mobile alla parete deve essere eseguito da persone esperte, dato che occorrono tasselli adeguati.
- NL** **Opgelet:** een vakkundige persoon dient het meubelstuk aan de muur te bevestigen; voor de montage aan de muur zijn immers aangepaste pluggen vereist.
- PL** **Uwaga:** Mocowanie mebla do ściany mogą przeprowadzić wyłącznie wykwalifikowane osoby, z uwagi na zastosowanie odpowiednio dopasowanych kołków do rodzaju ściany.
- CZ** **Pozor:** Montáž nábytku na stěnu musí provést odborník, protože k montáži na stěnu jsou zapotřebí upravené hmoždinky.
- SK** **Pozor:** Upevnenie nábytku na stenu musí vykonať odborník, nakoľko sú pre montáž na stenu potrebné vhodné hmoždinky.
- HU** **Figyelem:** A bútorelemek falra rögzítését szakembernek kell végeznie, mert a rögzítéshez megfelelő tiplít kell használni.
- RO** **Atenție:** Fixarea la perete a piesei de mobilier se realizează numai de către personal competent, deoarece montajul de perete necesită dibluri adecvate.
- TR** **Dikkat:** Mobilya parçasının duvara sabitlenmesi, duvar montajı için özel uyarlanmış dübeller gerektirdiğinden bu iş sadece bu konuda uzman bir kişi tarafından gerçekleştirilmelidir.
- RU** **Внимание:** Поскольку для монтажа на стене необходимо использовать специальные дюбели, мебель должна быть закреплена на стене квалифицированным персоналом.
- LV** **Uzmanību:** Mēbeles montāžai pie sienas paredzēts izmantot speciālus dībeļus. Ietecams šo darbu veikt kvalificētam darbiniekam.

- ⒸZ) Úprava dverí
- Ⓓ) Das Richten einer Türe
- Ⓕ) Réglage d'une porte.
- ⒽU) Beállítás egy ajtó
- Ⓘ) Regolare una porta
- ⒻV) Durvju regulēšana
- ⒼNL) Instellen van een deur
- ⒼPL) Regulacja drzwi
- ⒼRO) Reglarea o ușă
- ⒼRU) Регулировка Дверей
- ⒼSK) Úprava dverí
- ⒼTR) Bir kapı ayarlama
- ⒼUK) Adjusting a door
- ⒼFIN) Oven säätö

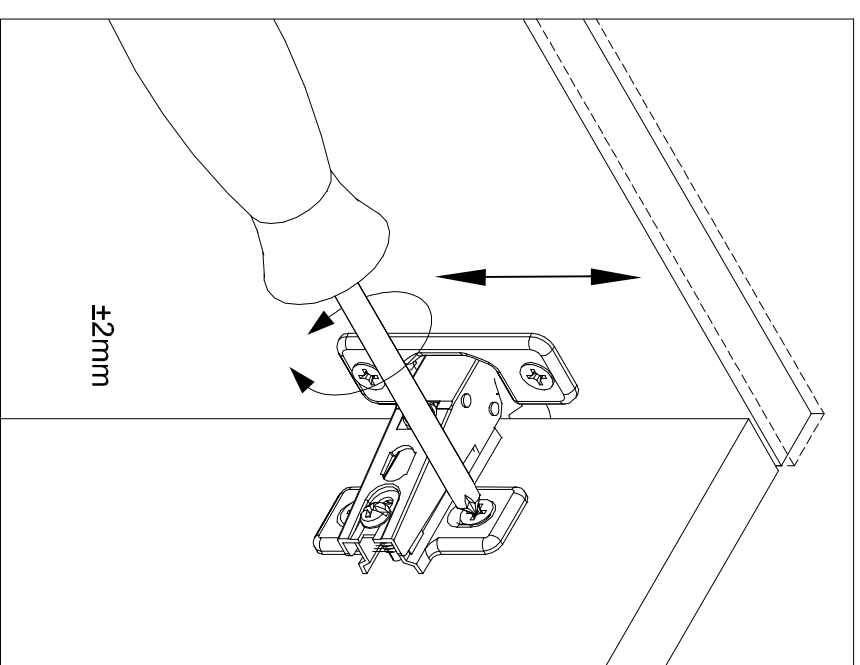
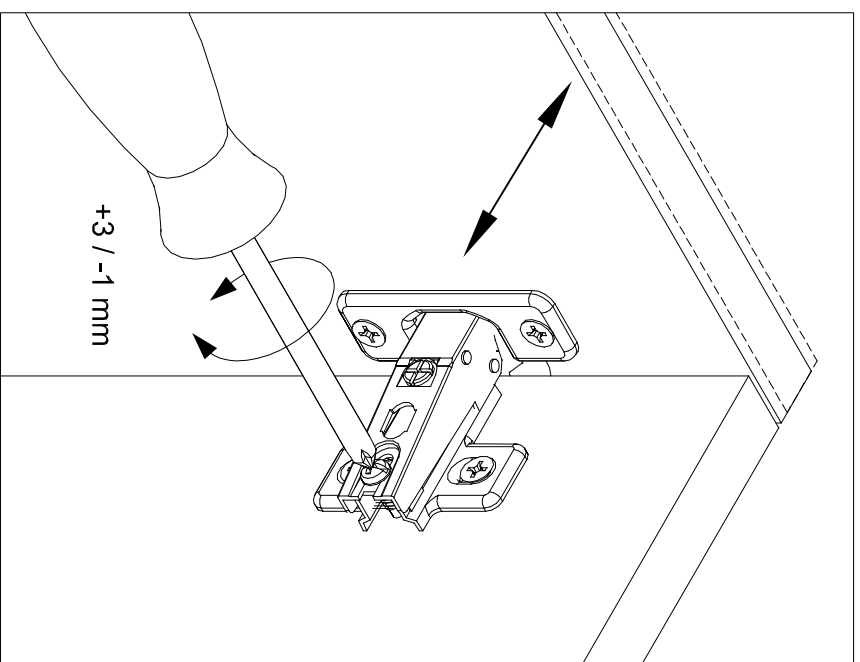
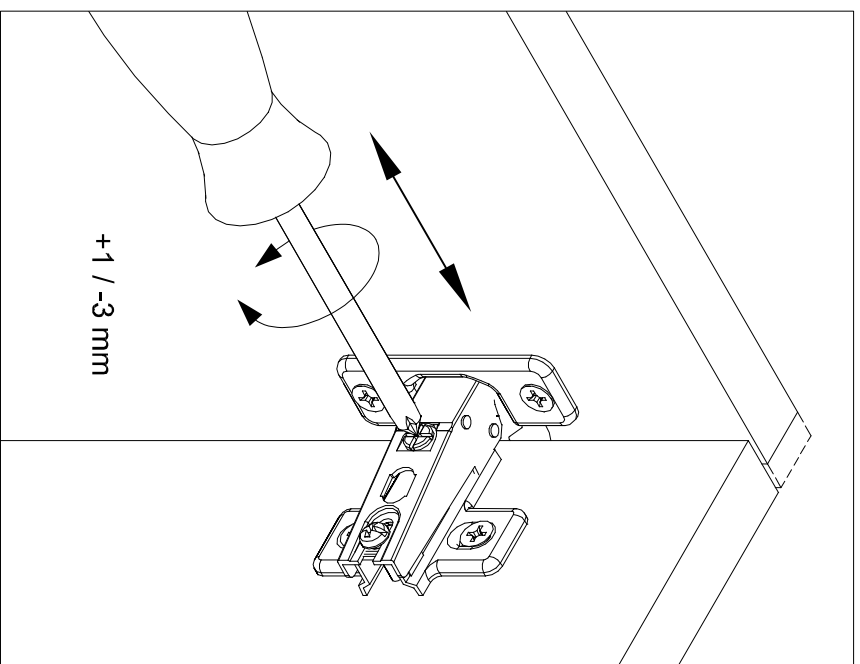





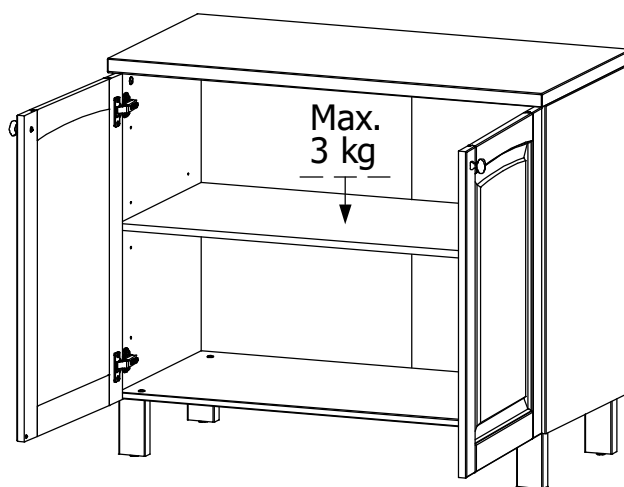
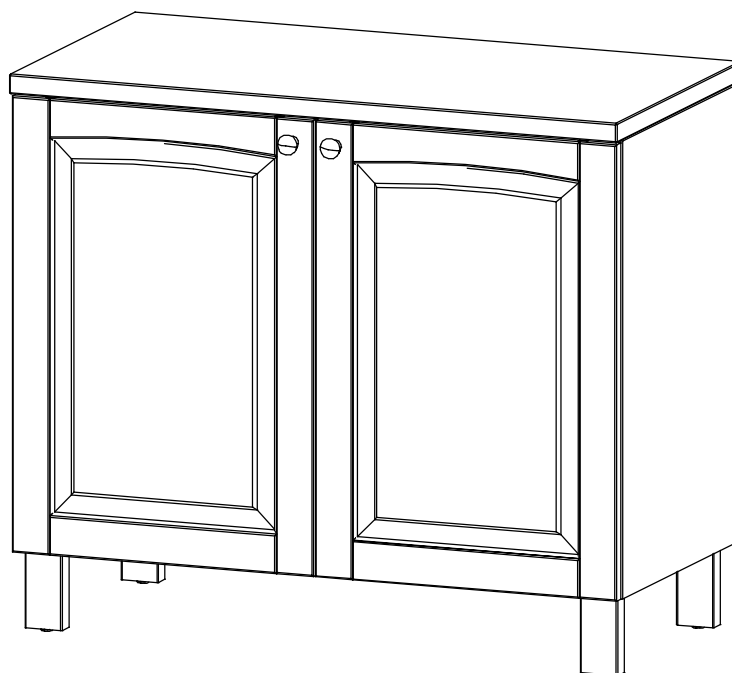
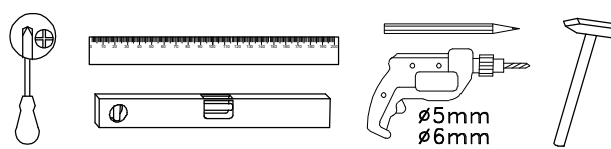
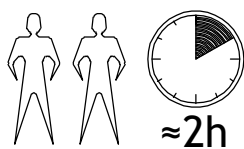



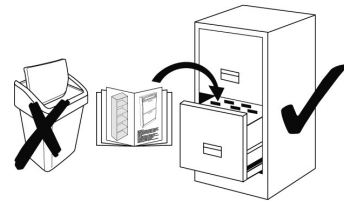
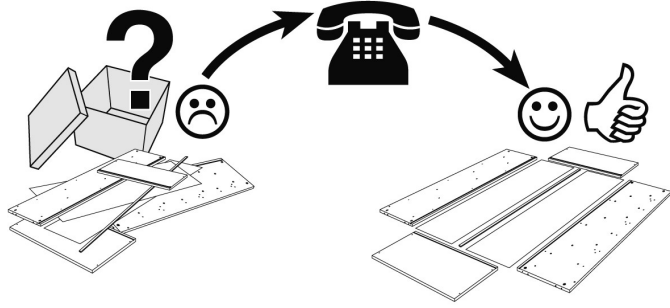









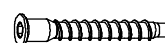

Art. 82723532 63297664

LKZ 75007



idp68240-1 idp68240-2

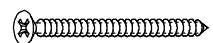

Service • Assistenza • Dienstverlening • Serwis Servis • Szerviz • Сервисная служба	
Name • Nom • Nome • Naam Nazwa • Jméno • Názov • Név Denumire • Isim • Название	
Nr • No • N • Номер • Č • Sz	
Тур • Туре • Тір • Тірус • Тіро Тип	
	
	

			H1		x12 ø 8x30	D2		x12 ø 5/11x34
D4		x6 ø 17	D5		x12 ø 15x12,5	D36		x12 15x15x10
D24		x4 ø 13	A5		x1 SW4	A27		x4 ø 7x50
G101		x4 2mm	G98		x4 ø 35	A1		x8 ø 3,5x15
B122		x2	A278		x2 M4x15	A16		x4 M4x25
N3		x2 ø 7x1,5	D1		x4 ø 5	A10		x4 ø 4x16
D31		x2	H8		x2 ø 6x35	A69		x2 ø 4x60

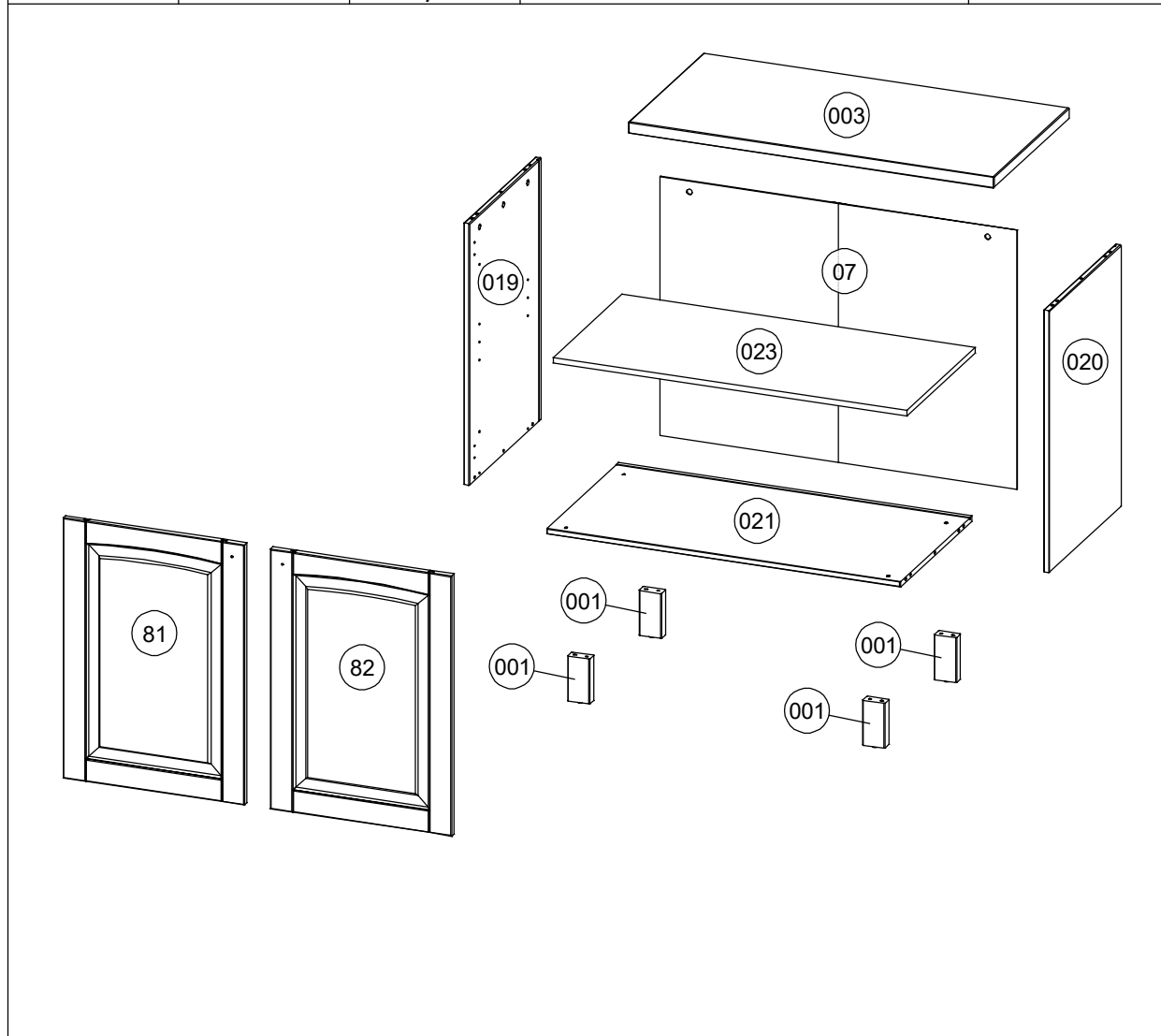
Teil Nr. Pièces Nr. Pieces Nr. Часть Ном. Kawalek Nr. Parça No Kusù Nr. Kusov Nr. Pezzi Nr. Nr piese. Darab száma. Stukken Nr. Kārtas Nr.	Anzahl Quantité Quantity Количество Ilość Miktar Množství Množstvo Quantità Cantitatea Mennyiség Hoeveelheid Skaitis	Kasten Nr. Colli Nr. Colli Nr. Коробка Ном. Polu Nr. Kutusu Nr. Kolonka Č. Počet balení Colli Nr. Nu pachete Colli száma. Colli Nr. Kastes Nr.	Maß, mm Dimensions, mm Dimensions, mm Размеры, mm Wymiary, mm Boyutlar, mm Rozměry, mm Rozmery, mm Dimensioni, mm Dimensiuni, mm Méterek, mm Afmetingen, mm Izmēri, mm	✓
001	4	1 / 1	120 x 60 x 30	
003	1	1 / 1	980 x 500 x 30	
019	1	1 / 1	700 x 476 x 15	
020	1	1 / 1	700 x 476 x 15	
021	1	1 / 1	948 x 476 x 15	
023	1	1 / 1	948 x 456 x 15	
07	1	1 / 1	693 x 956 x 3	
81	1	1 / 1	696 x 486 x 18	
82	1	1 / 1	696 x 486 x 18	





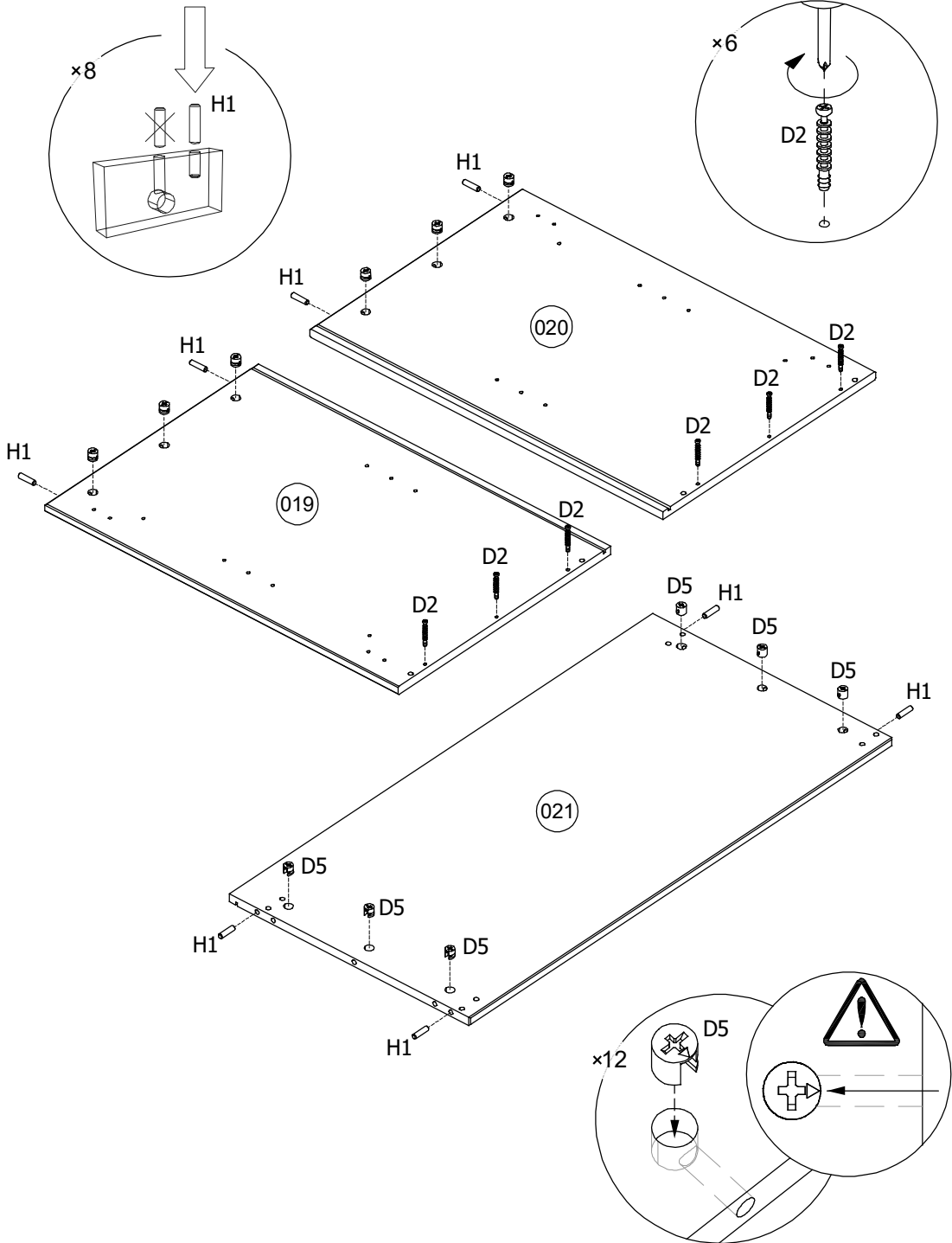

idp68240-1 idp68240-2

H1	 x8 ø 8x30	D2	 x6 ø 5/11x34	D5	 x12 ø 15x12,5
----	--	----	---	----	--

1



idp68240-1 idp68240-2

D2	 x6 ø 5/11x34	D31	 x2	A10	 x4 ø4x16
G101	 x4 2mm				

2

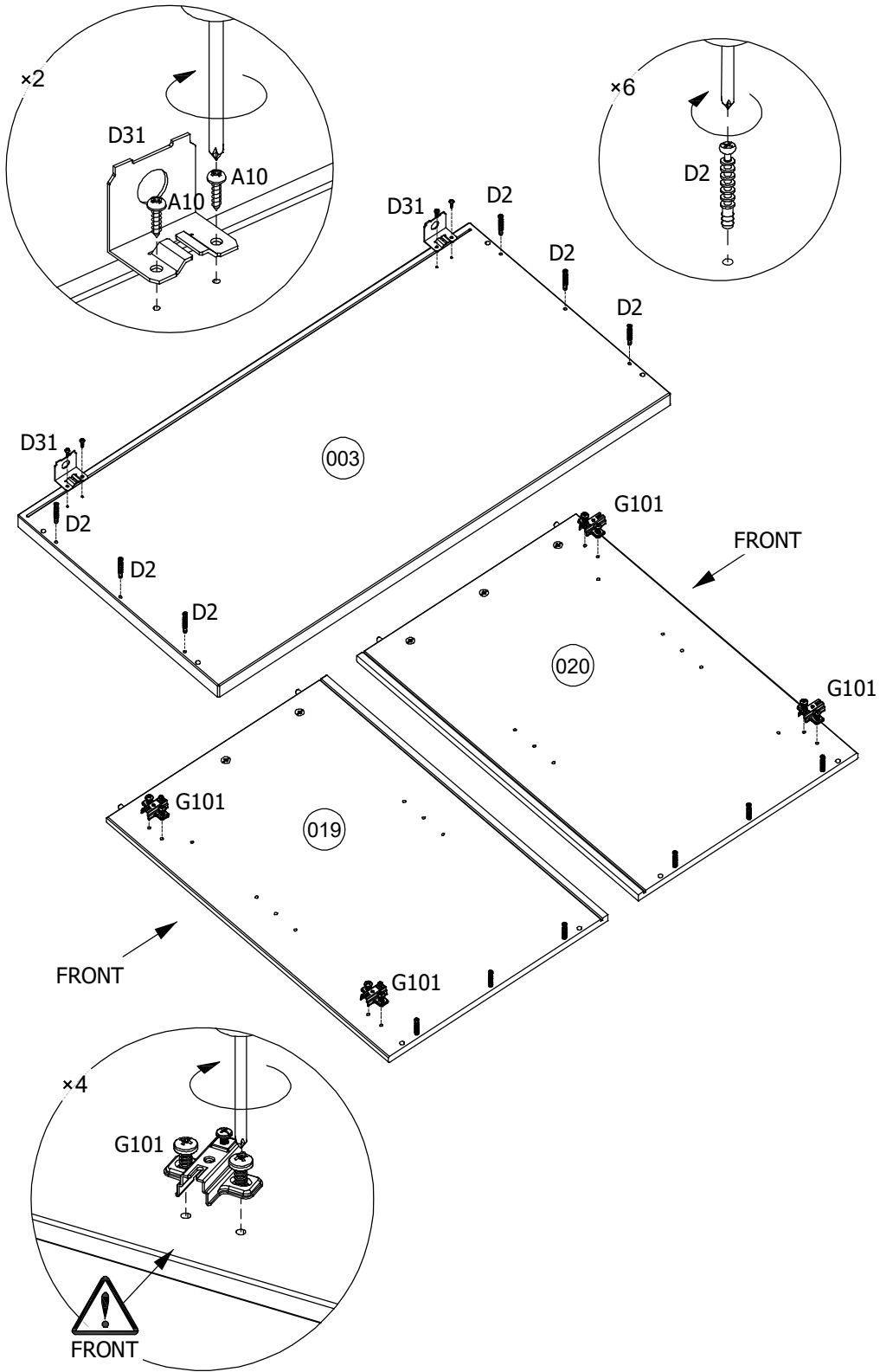

idp68240-1 idp68240-2

3

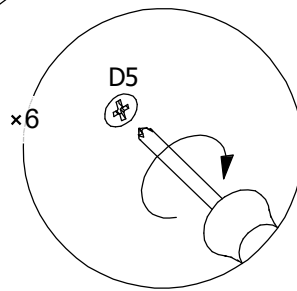
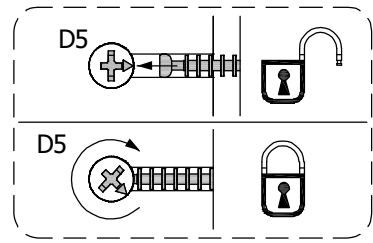
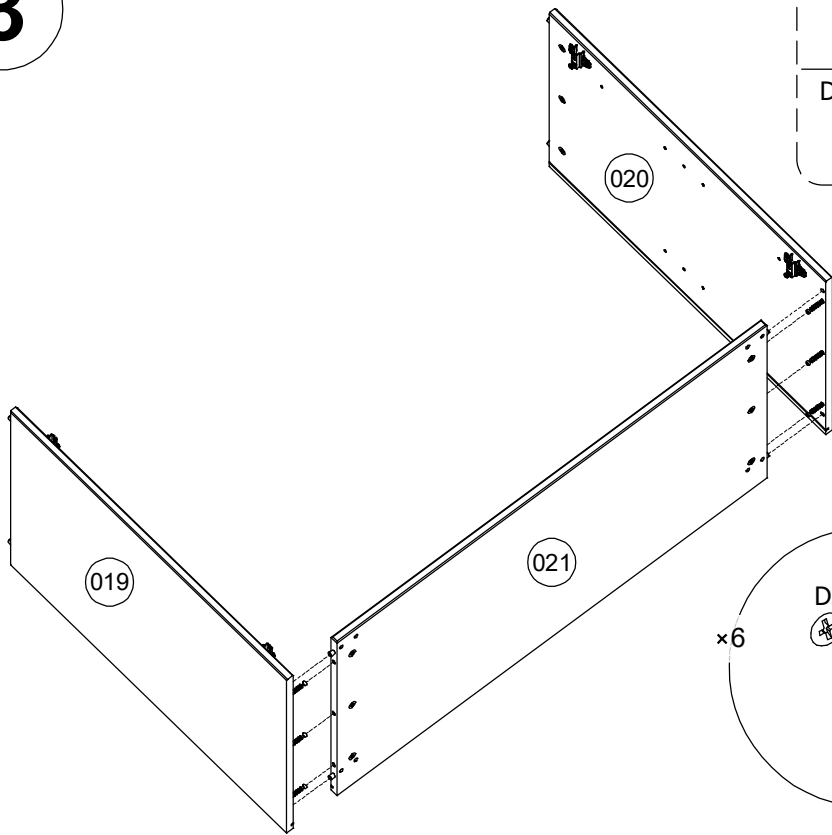

4

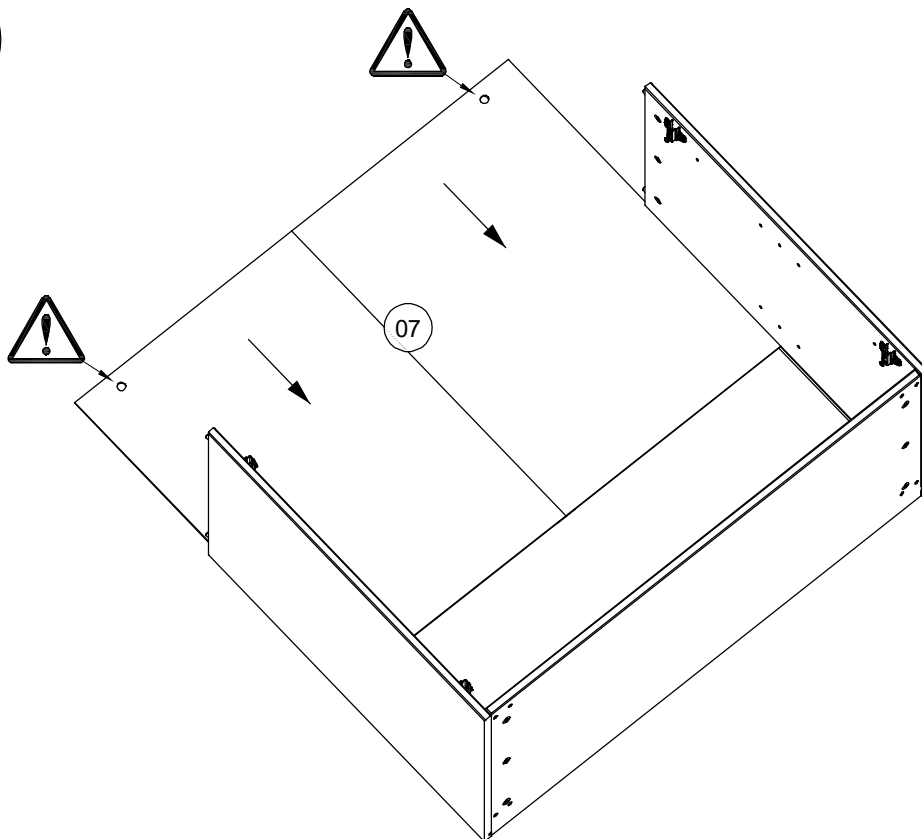

5

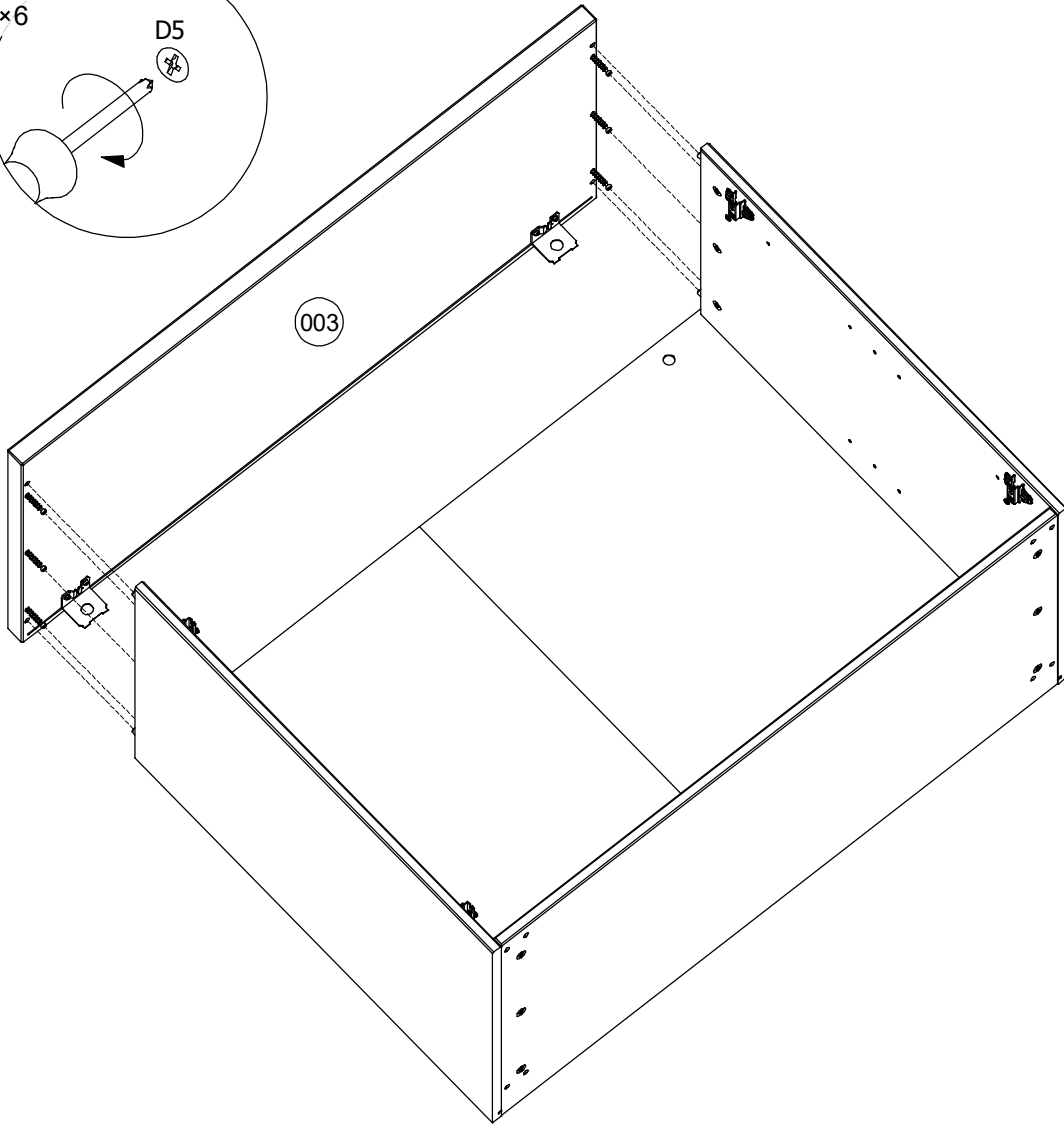
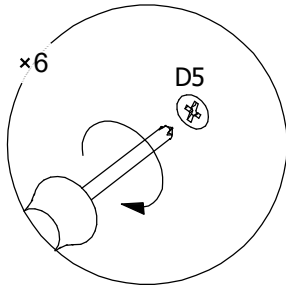
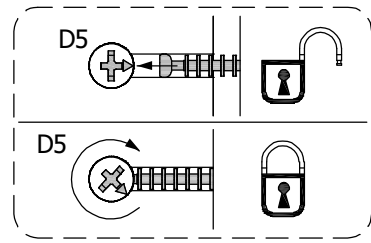

H1



x4

ø 8x30

6

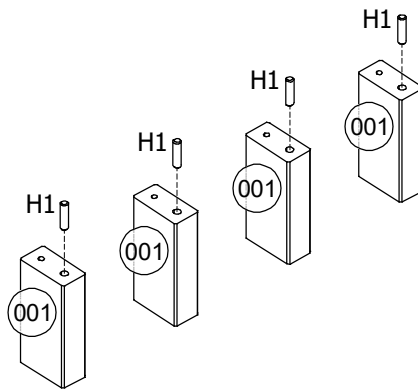

A27

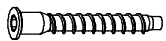

x4

ø 7x50

A5

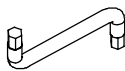

x1

SW4

7

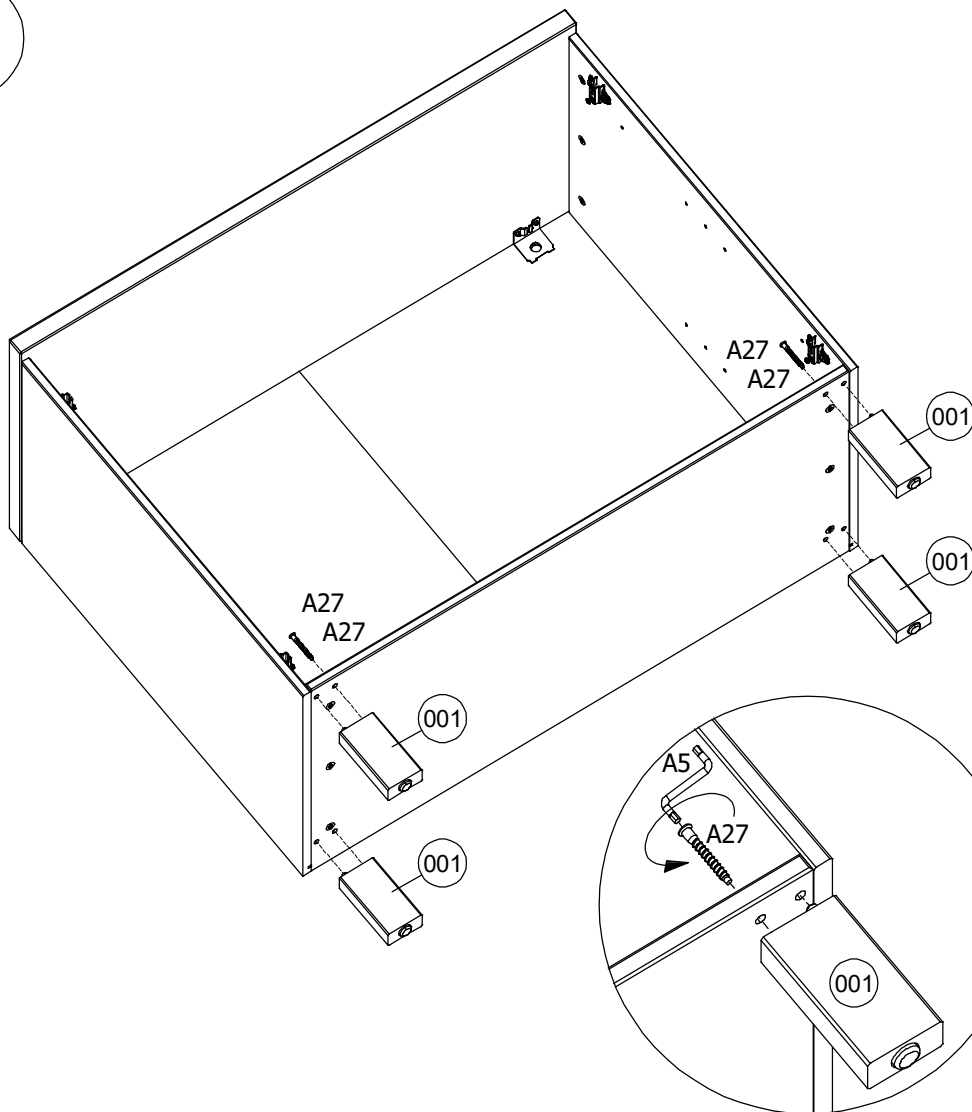

idp68240-1 idp68240-2

8

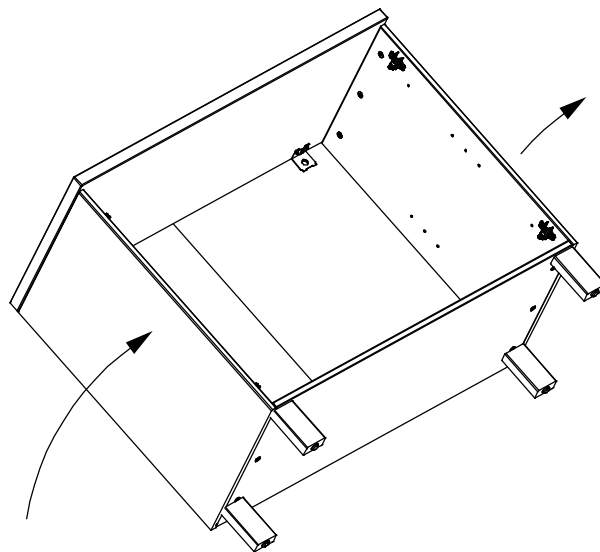
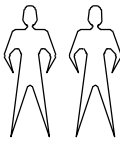

D36



x12

15x15x10

9

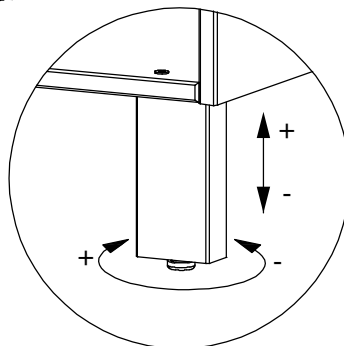
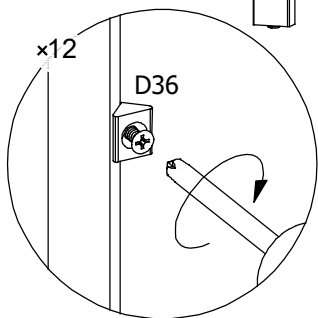
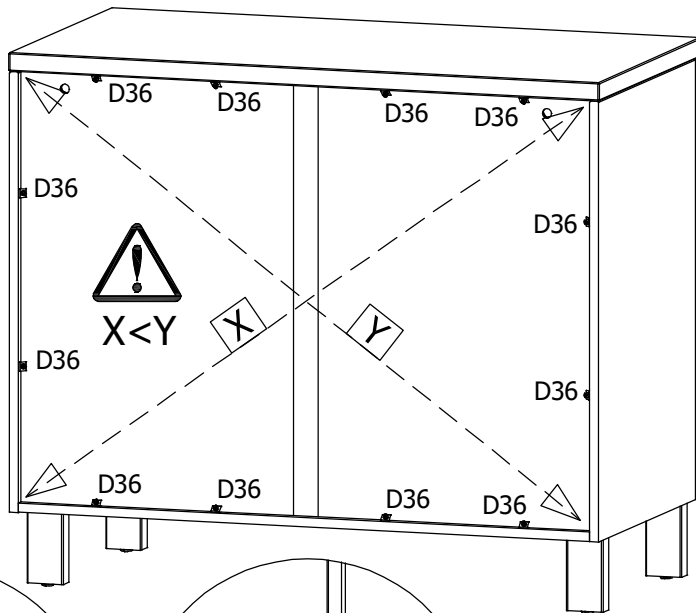
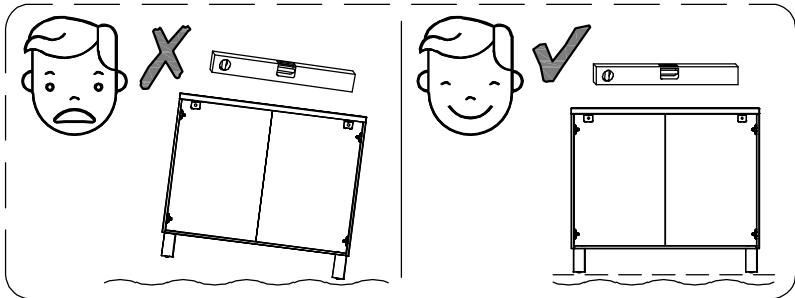

idp68240-1 idp68240-2

10

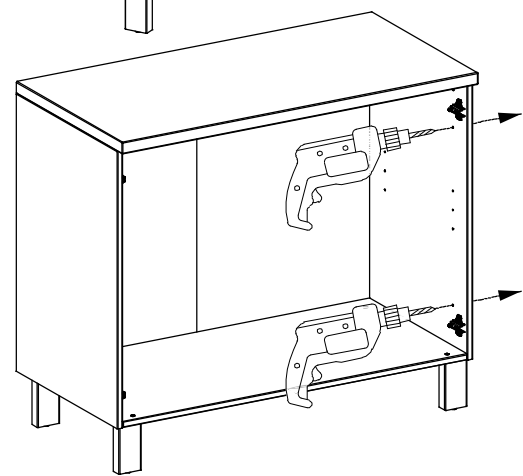
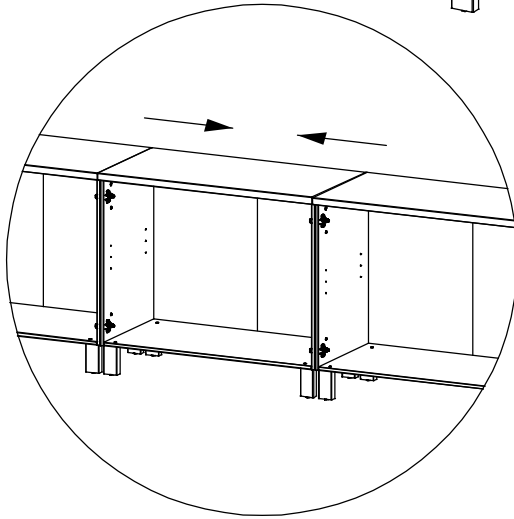
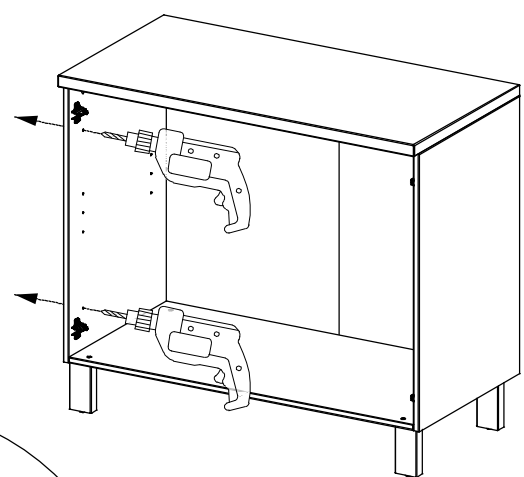
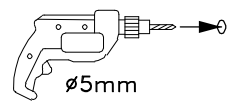

A278



x2

M4x15

A16



x2

M4x25

11

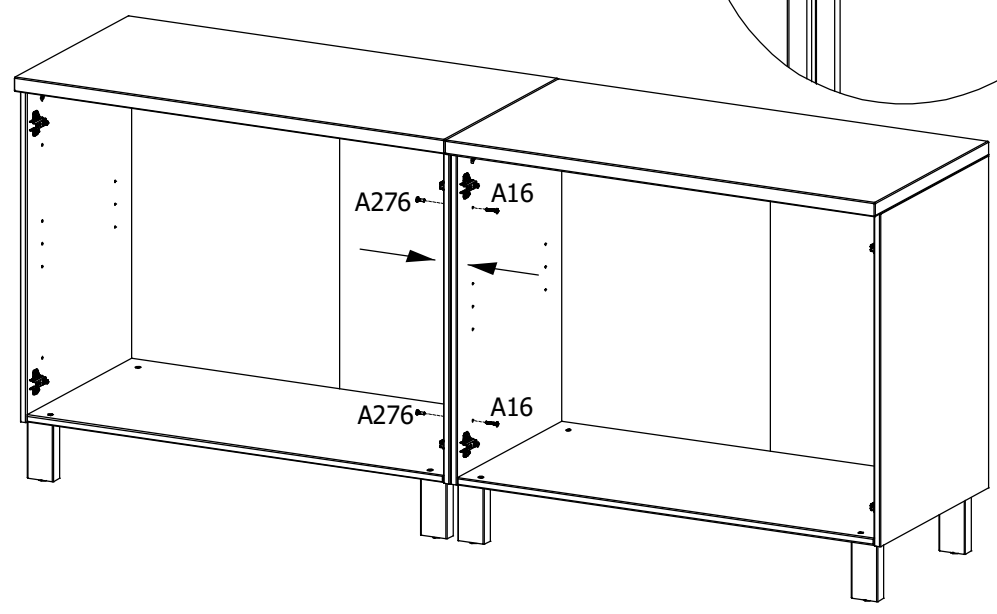
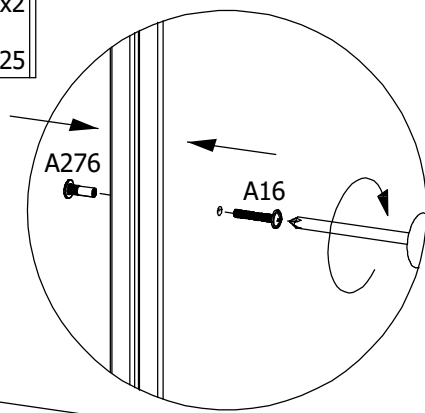

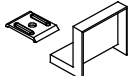
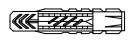
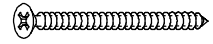

idp68240-1 idp68240-2

D31	 x2	H8	 x2 ø 6x35	A69	 x2 ø 4x60
-----	--	----	--	-----	--

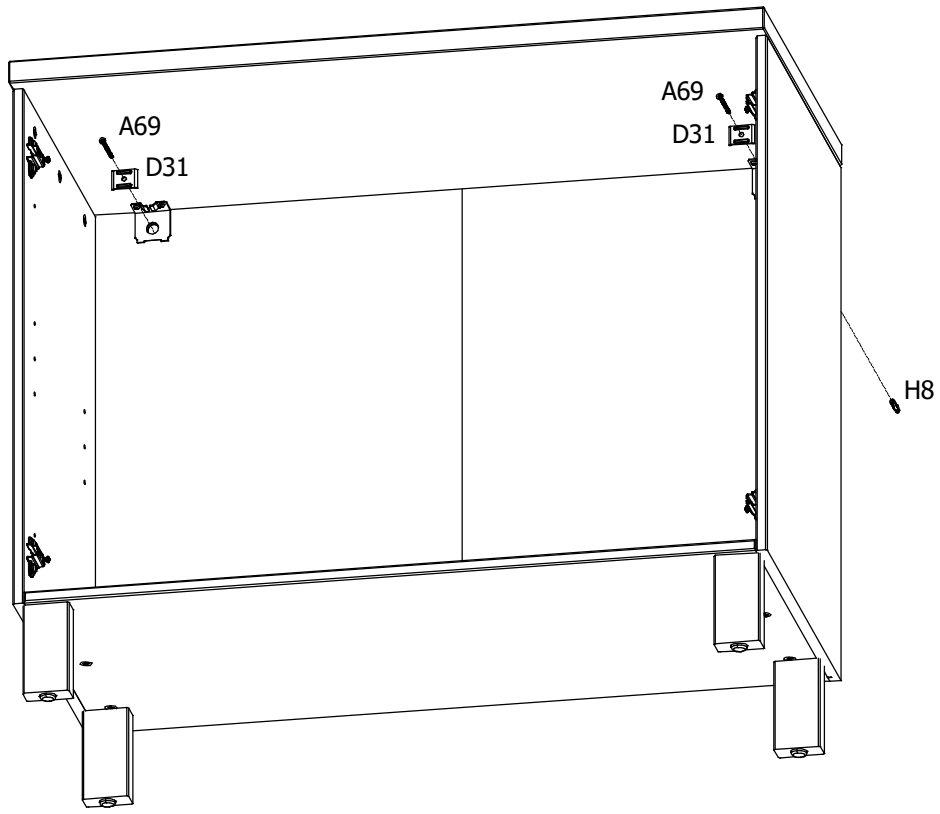
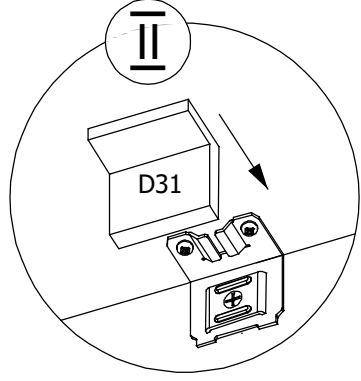
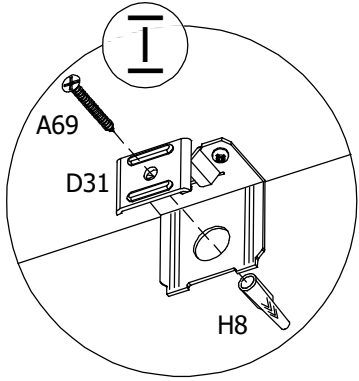
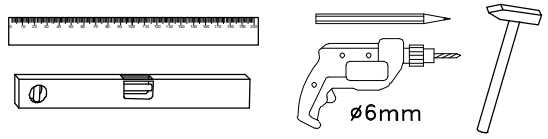
12



idp68240-1 idp68240-2

D1		x4 ø5	D4		x6 ø17	D24		x4 Ø13
----	---	----------	----	---	-----------	-----	---	-----------

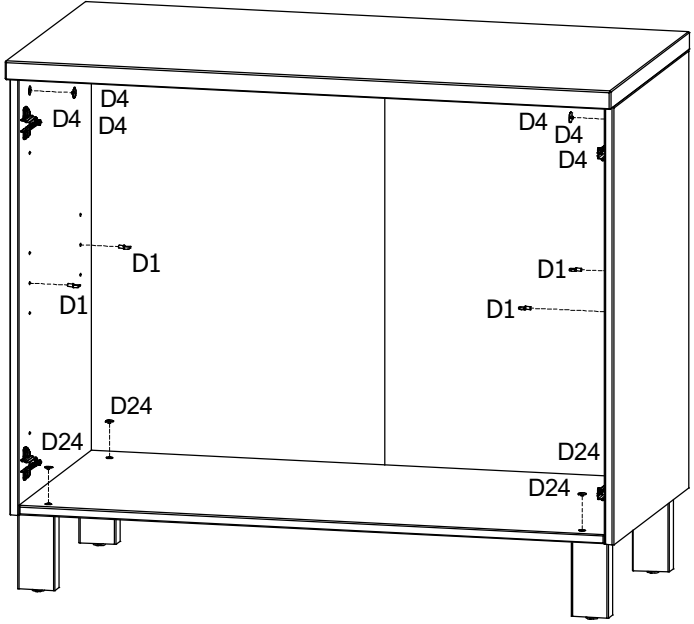
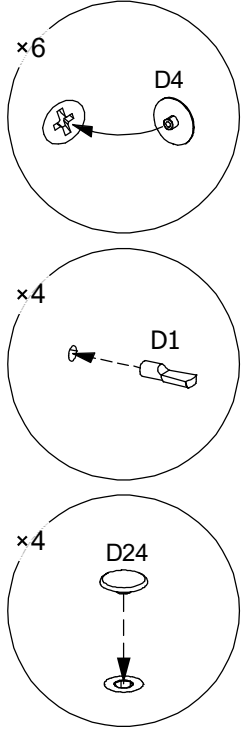

13

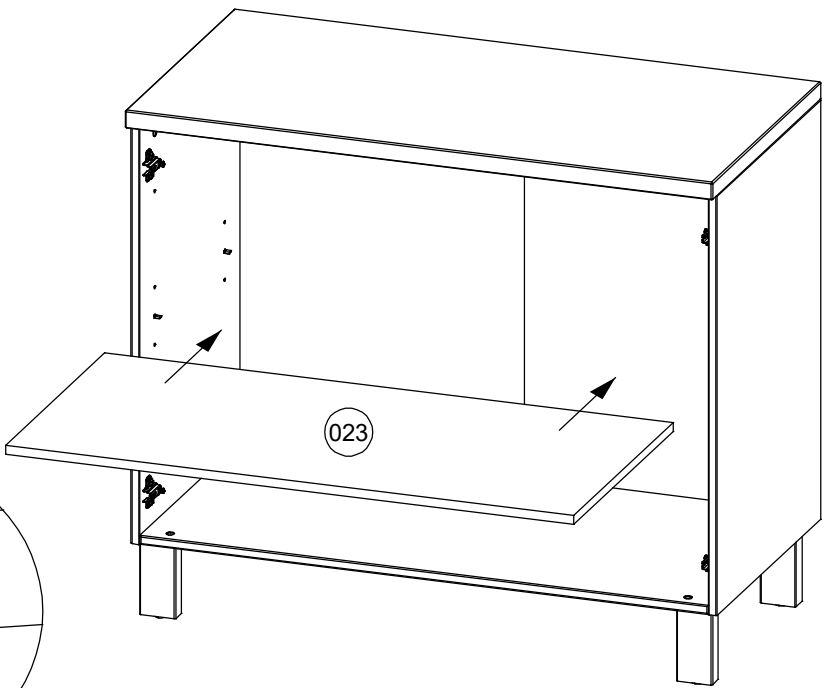
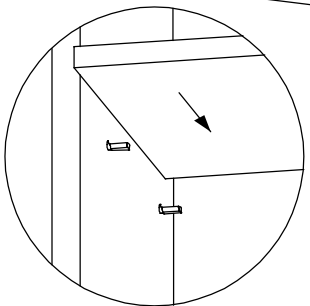

14

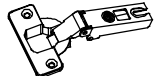

idp68240-1 idp68240-2

B122		x2	G98		x4 ø35	A1		x8 ø 3,5x15
A16		x2 M4x25						

15

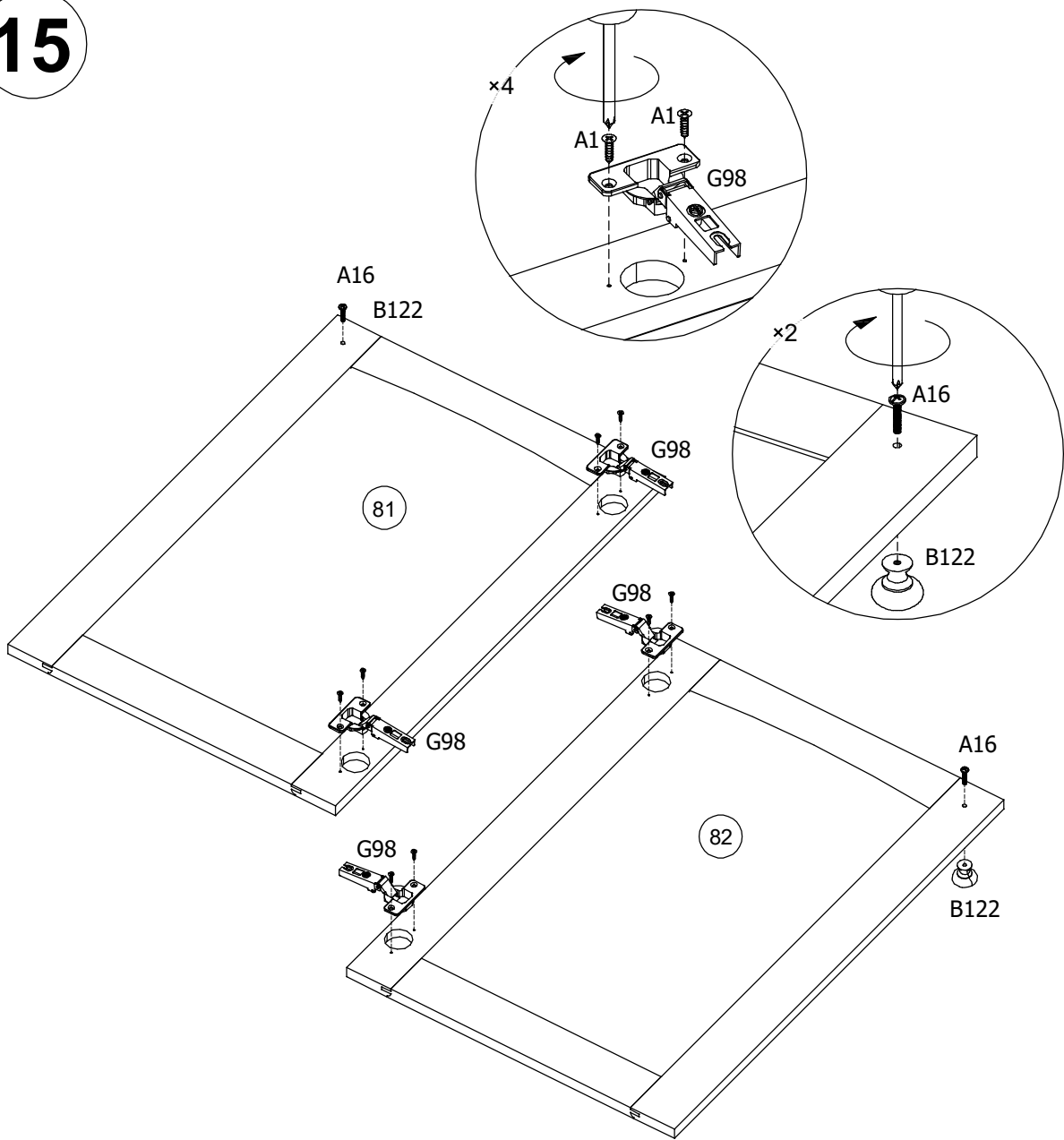

idp68240-1 idp68240-2

N3



x2

Ø7x1,5

16

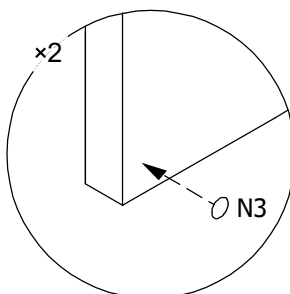
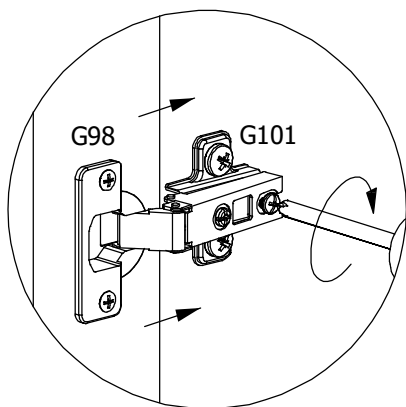
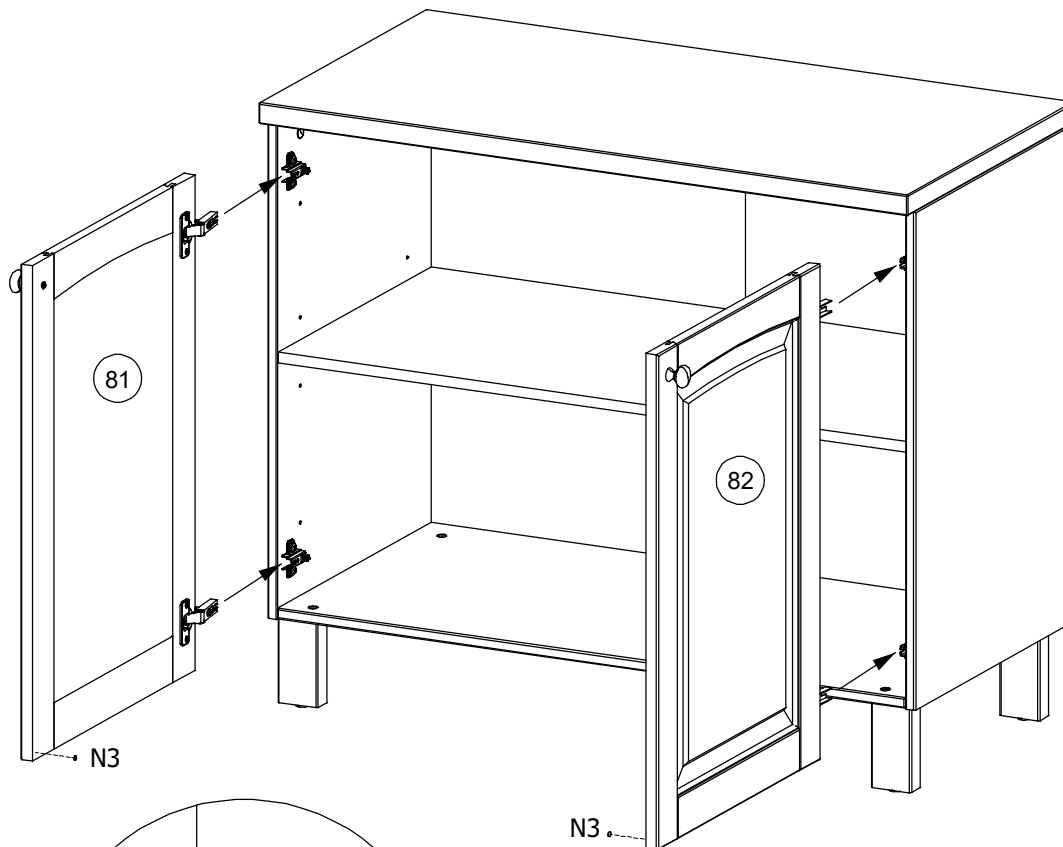

idp68240-1 idp68240-2

H8 

A69 
 ø4x60

 ø6mm

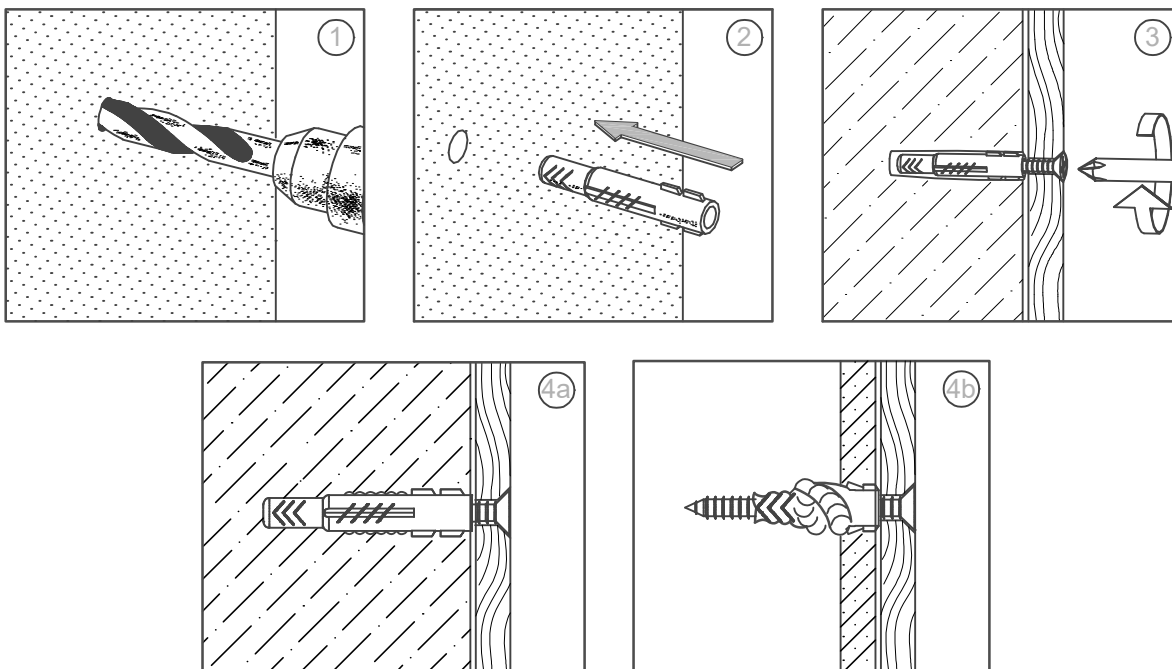

- D** **Achtung:** Die Befestigung des Möbelstückes an der Wand muss von einer fachkundigen Person vorgenommen werden, da für die Montage an die Wand angepasste Dübel erforderlich sind.
- GB** **Attention:** A qualified professional is required when mounting furniture to the wall since dowels corresponding to the wall are required for this.
- FR** **Attention :** La fixation du meuble contre le mur doit être effectuée par une personne compétente car, pour le montage mural, il faut utiliser des chevilles adaptées.
- IT** **Attenzione:** Il fissaggio del mobile alla parete deve essere eseguito da persone esperte, dato che occorrono tasselli adeguati.
- NL** **Opgelet:** een vakkundige persoon dient het meubelstuk aan de muur te bevestigen; voor de montage aan de muur zijn immers aangepaste pluggen vereist.
- PL** **Uwaga:** Mocowanie mebla do ściany mogą przeprowadzić wyłącznie wykwalifikowane osoby, z uwagi na zastosowanie odpowiednio dopasowanych kołków do rodzaju ściany.
- CZ** **Pozor:** Montáž nábytku na stěnu musí provést odborník, protože k montáži na stěnu jsou zapotřebí upravené hmoždinky.
- SK** **Pozor:** Upevnenie nábytku na stenu musí vykonať odborník, nakoľko sú pre montáž na stenu potrebné vhodné hmoždinky.
- HU** **Figyelem:** A bútorelemek falra rögzítését szakembernek kell végeznie, mert a rögzítéshez megfelelő tiplit kell használni.
- RO** **Atenție:** Fixarea la perete a piesei de mobilier se realizează numai de către personal competent, deoarece montajul de perete necesită dibluri adecvate.
- TR** **Dikkat:** Mobilya parçasının duvara sabitlenmesi, duvar montajı için özel uyarlanmış dübeller gerektirdiğinden bu iş sadece bu konuda uzman bir kişi tarafından gerçekleştirilmelidir.
- RU** **Внимание:** Поскольку для монтажа на стене необходимо использовать специальные дюбели, мебель должна быть закреплена на стене квалифицированным персоналом.
- LV** **Uzmanību:** Mēbeles montāžai pie sienas paredzēts izmantot speciālus dībeļus. Ietecams šo darbu veikt kvalificētam darbiniekam.



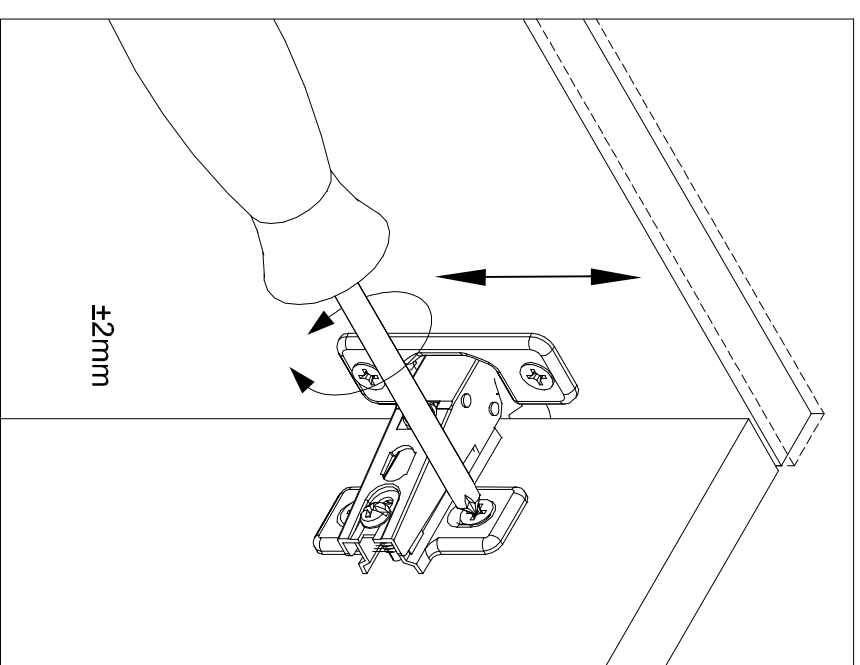
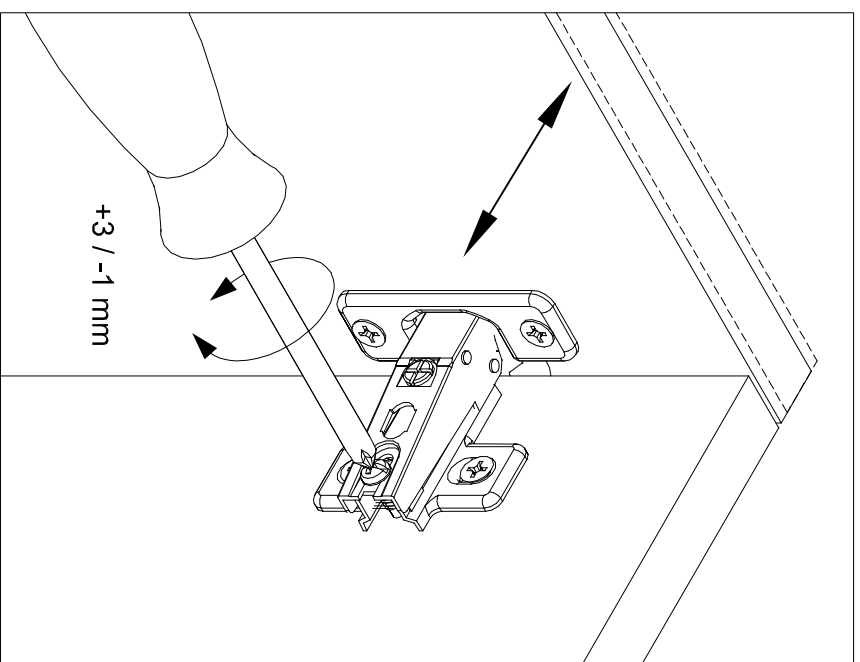
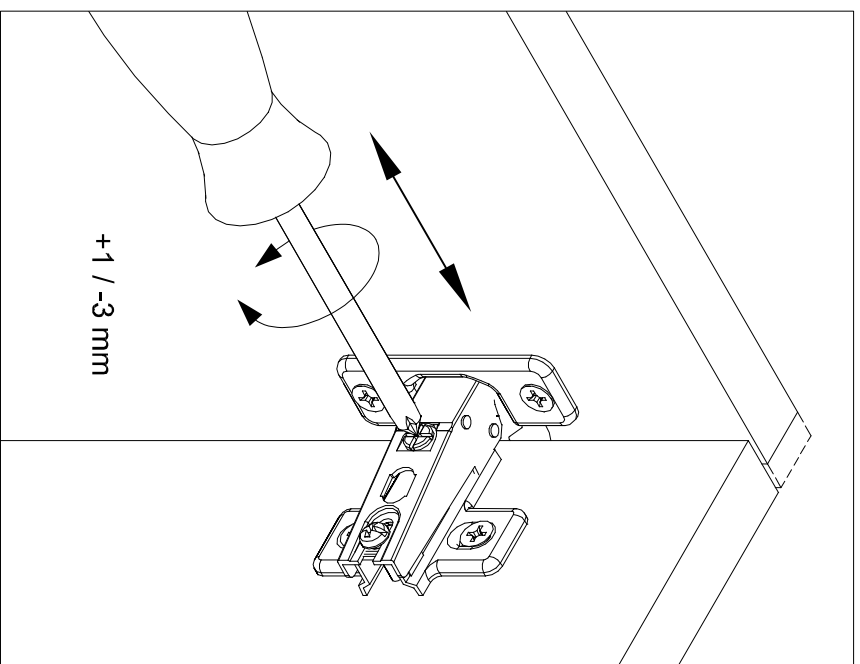

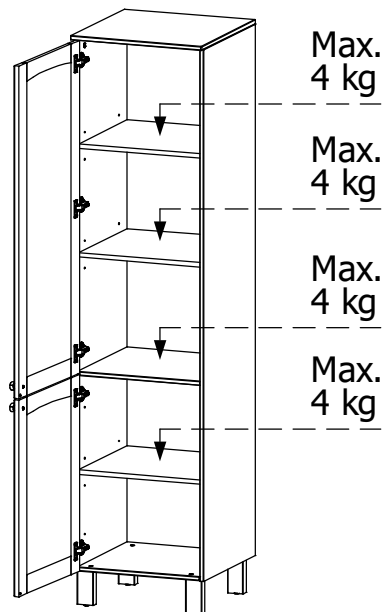
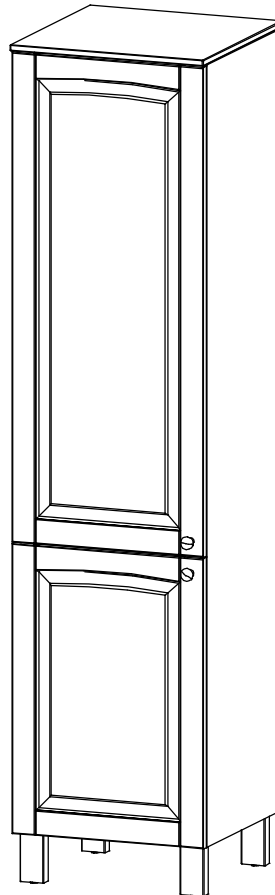
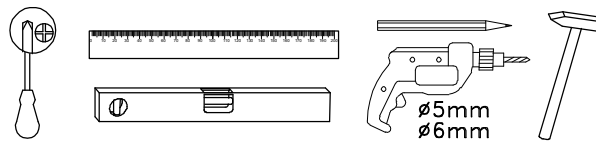
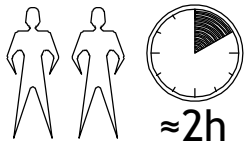



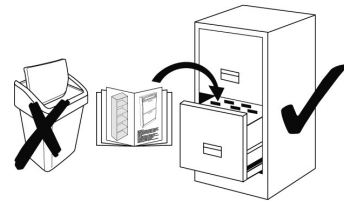
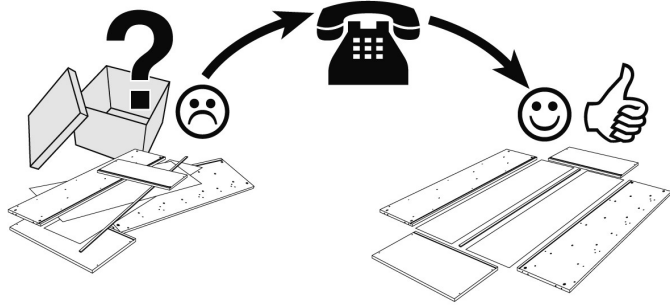







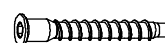

- ⒸZ) Úprava dverí
- Ⓓ) Das Richten einer Türe
- Ⓕ) Réglage d'une porte.
- ⒽU) Beállítás egy ajtó
- Ⓘ) Regolare una porta
- Ⓕ) Durvju regulēšana
- ⒼNL) Instellen van een deur
- ⒼPL) Regulacja drzwi
- ⒼRO) Reglarea o ușă
- ⒼRU) Регулировка Дверей
- ⒼSK) Úprava dverí
- ⒼTR) Bir kapı ayarlaması
- ⒼUK) Adjusting a door
- ⒼFIN) Oven säätö





idp68245-1 idp68245-2

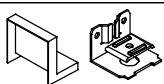

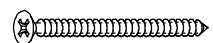
Service • Assistenza • Dienstverlening • Serwis Servis • Szerviz • Сервисная служба	
Name • Nom • Nome • Naam Nazwa • Jméno • Názov • Név Denumire • Isim • Название	
Nr • No • N • Номер • Č • Sz	
Тур • Туре • Тір • Тірус • Тіро Тип	
	
	

		H1		x18 ø 8x30	D2		x16 ø 5/11x34	
D4		x10 ø 17	D5		x16 ø 15x12,5	D36		x8 15x15x10
D24		x4 ø 13	A5		x1 SW4	A27		x4 ø 7x50
G101		x5 2mm	G98		x5 ø 35	A1		x10 ø 3,5x15
B122		x2	A278		x2 M4x15	A16		x4 M4x25
N3		x2 ø 7x1,5	D1		x12 ø 5	A10		x2 ø 4x16
D31		x1	H8		x1 ø 6x35	A69		x1 ø 4x60

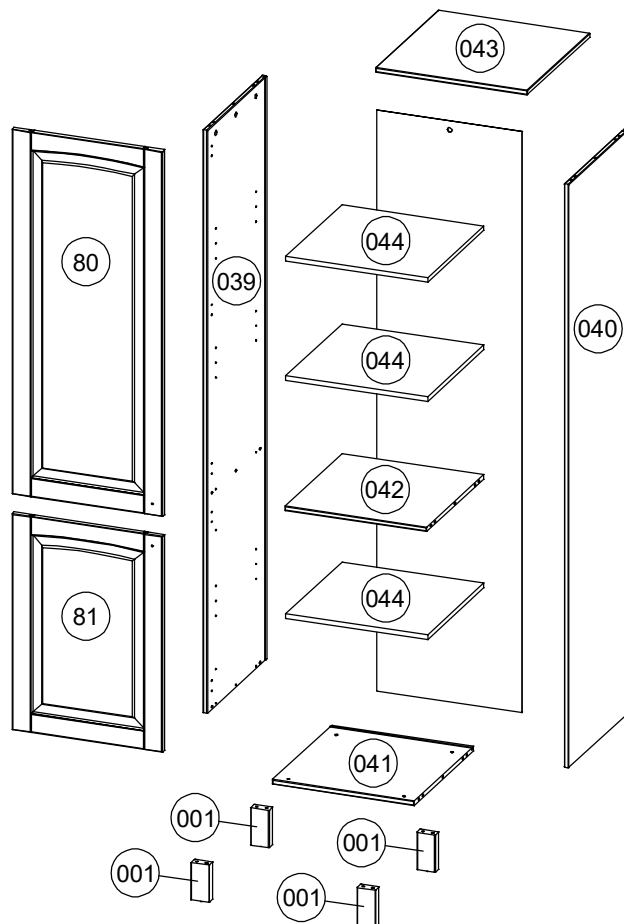
Teil Nr. Pièces Nr. Pieces Nr. Часть Ном. Kawalek Nr. Parça No Kusů Nr. Kusov Nr. Pezzi Nr. Nr piese. Darab száma. Stukken Nr. Kārtas Nr.	Anzahl Quantité Quantity Количество Ilość Miktar Množství Množstvo Quantità Cantitatea Mennyiség Hoeveelheid Skaitis	Kasten Nr. Colli Nr. Colli Nr. Коробка Ном. Polu Nr. Kutusu Nr. Kolonka Č. Počet balení Colli Nr. Nu pachete Colli száma. Colli Nr. Kastes Nr.	Maß, mm Dimensions, mm Dimensions, mm Размеры, mm Wymiary, mm Boyutlar, mm Rozměry, mm Rozmery, mm Dimensioni, mm Dimensiuni, mm Méterek, mm Afmetingen, mm Izmēri, mm	✓
001	4	1 / 2	120 x 60 x 30	
039	1	2 / 2	1880 x 476 x 15	
040	1	2 / 2	1880 x 476 x 15	
041	1	1 / 2	458 x 476 x 15	
042	1	1 / 2	458 x 458 x 15	
043	1	1 / 2	490 x 500 x 15	
044	3	1 / 2	458 x 450 x 15	
066	1	2 / 2	1873 x 467 x 3	
80	1	2 / 2	1176 x 486 x 18	
81	1	2 / 2	696 x 486 x 18	



idp68245-1 idp68245-2

H1		x14 ø 8x30	D5		x16 ø 15x12,5	D2		x16 ø 5/11x34
----	---	---------------	----	---	------------------	----	---	------------------

1

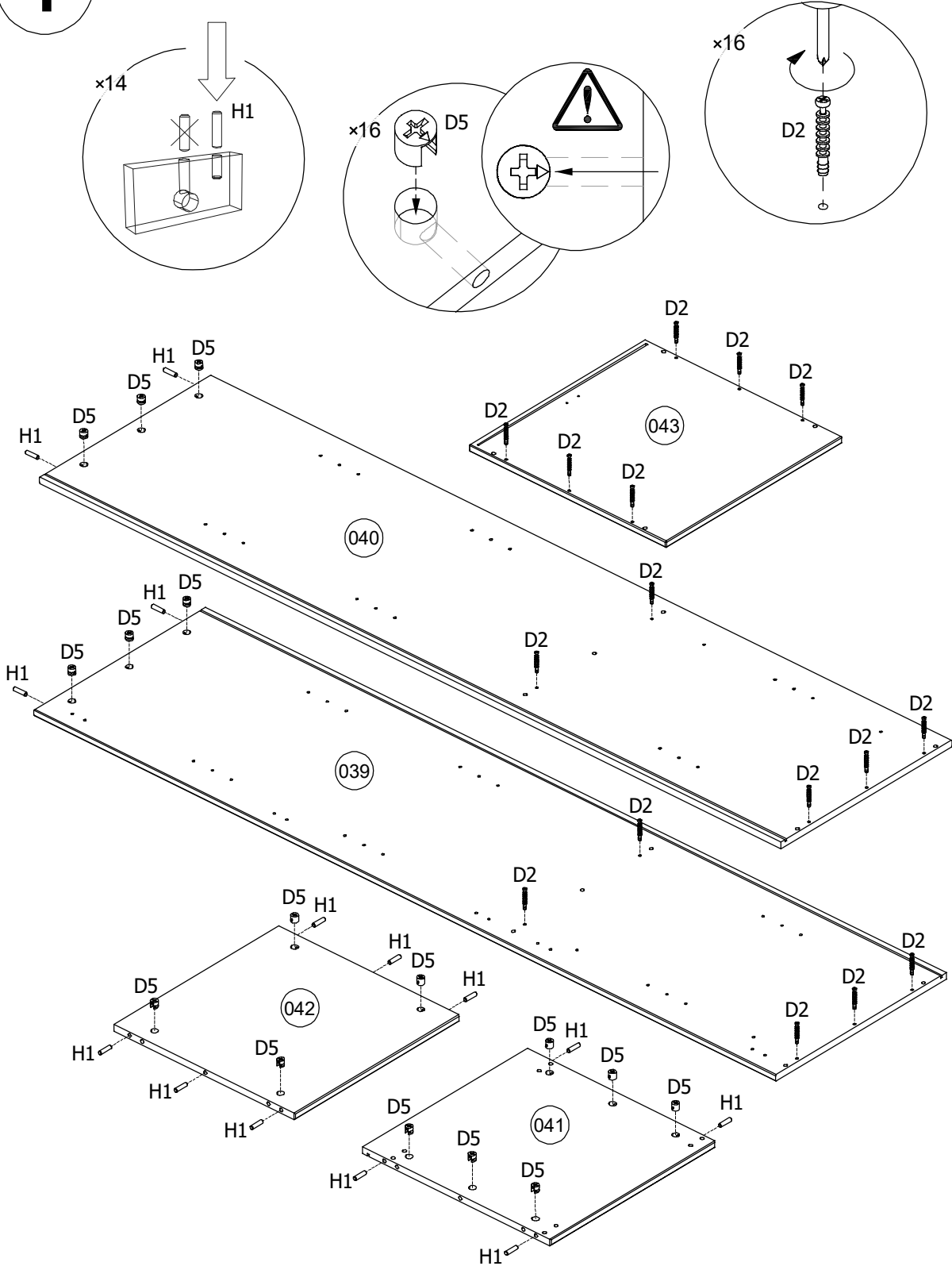

idp68245-1 idp68245-2

G101



x5

2mm

2

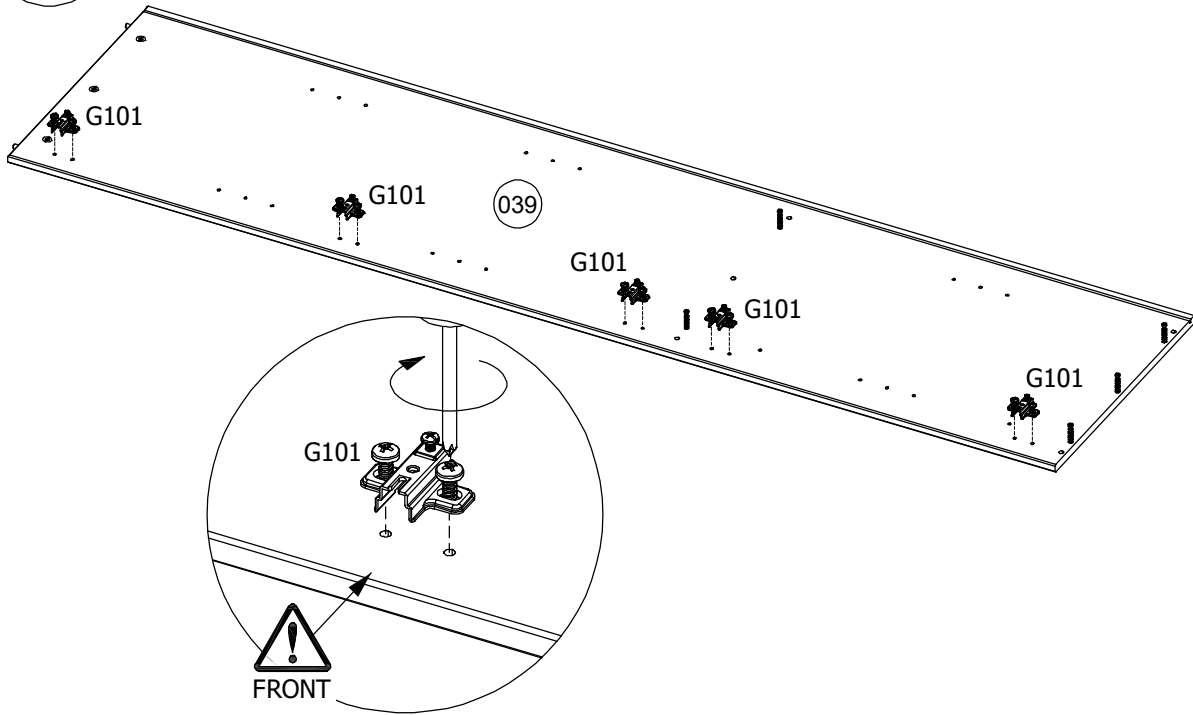

D31



x1

A10



x2

ø4x16

3

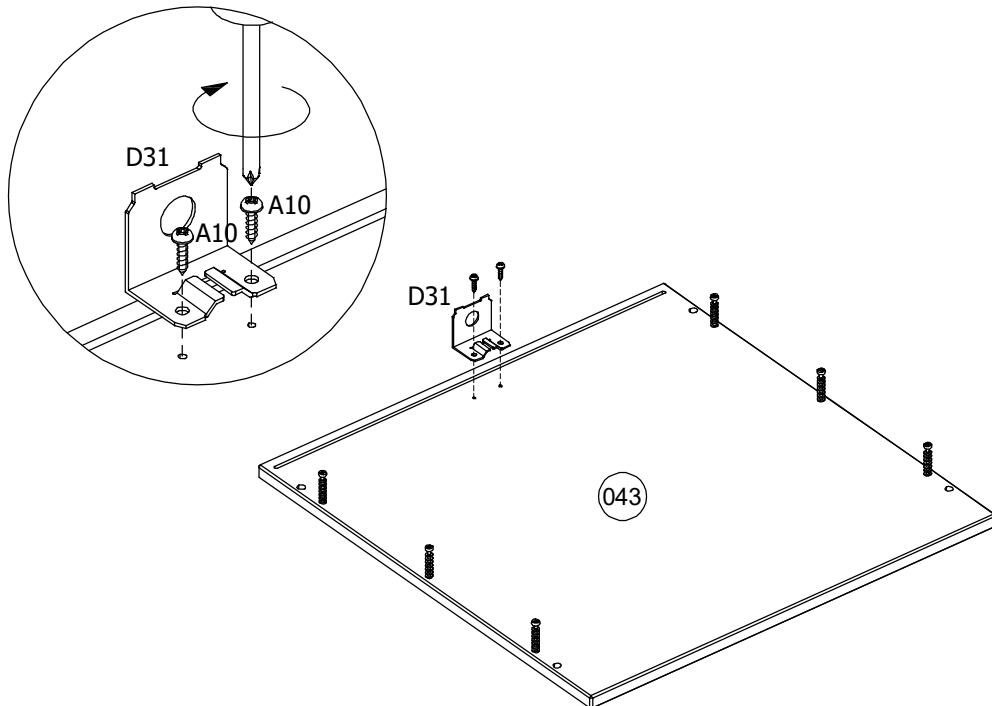

idp68245-1 idp68245-2

4

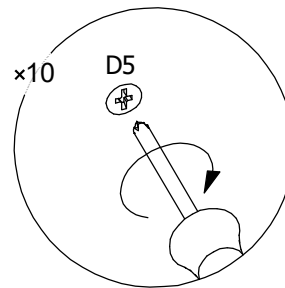
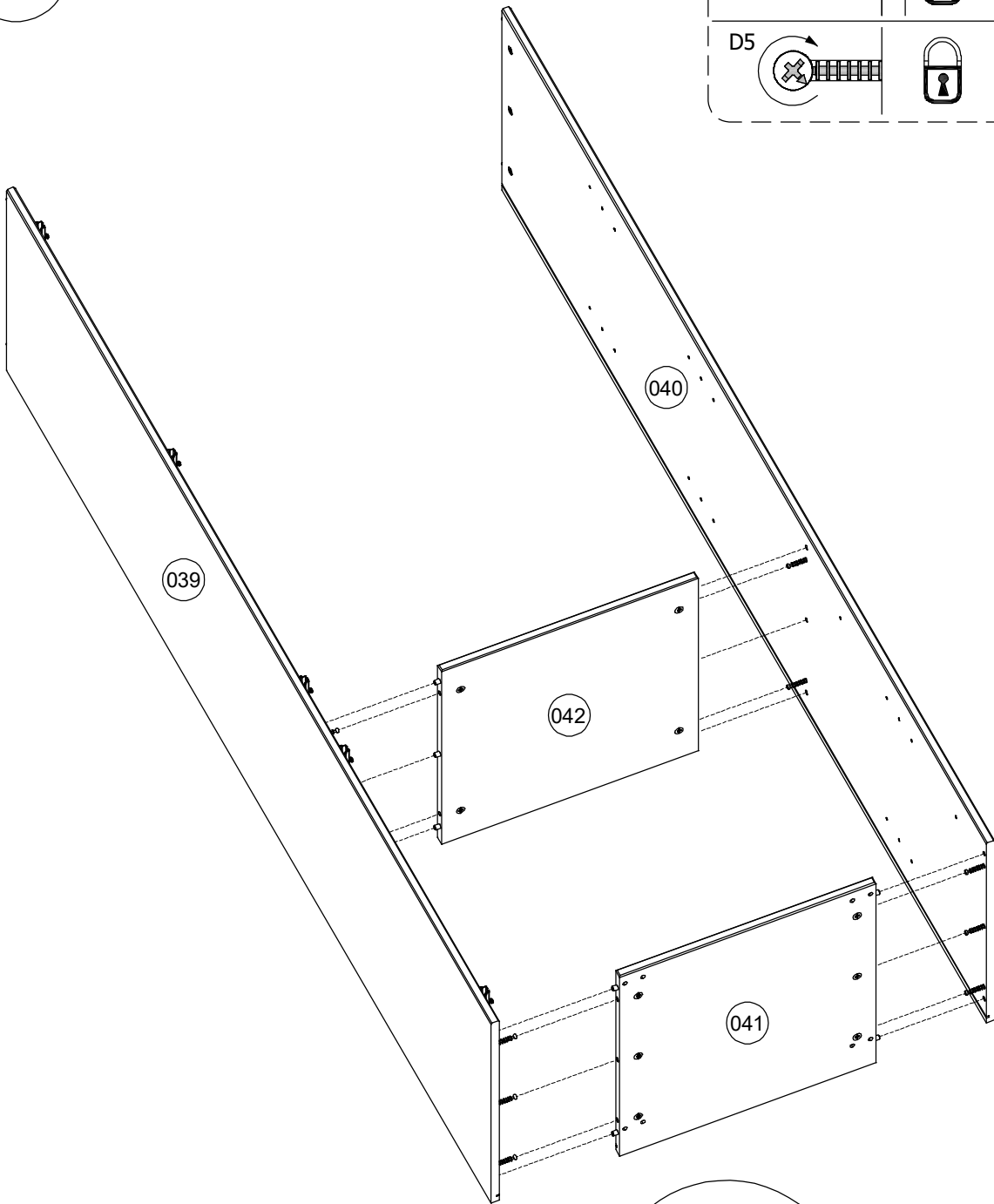
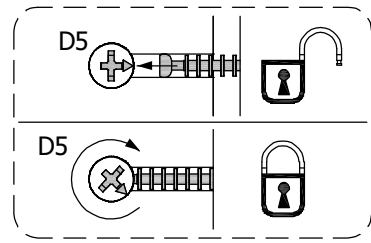

idp68245-1 idp68245-2

5

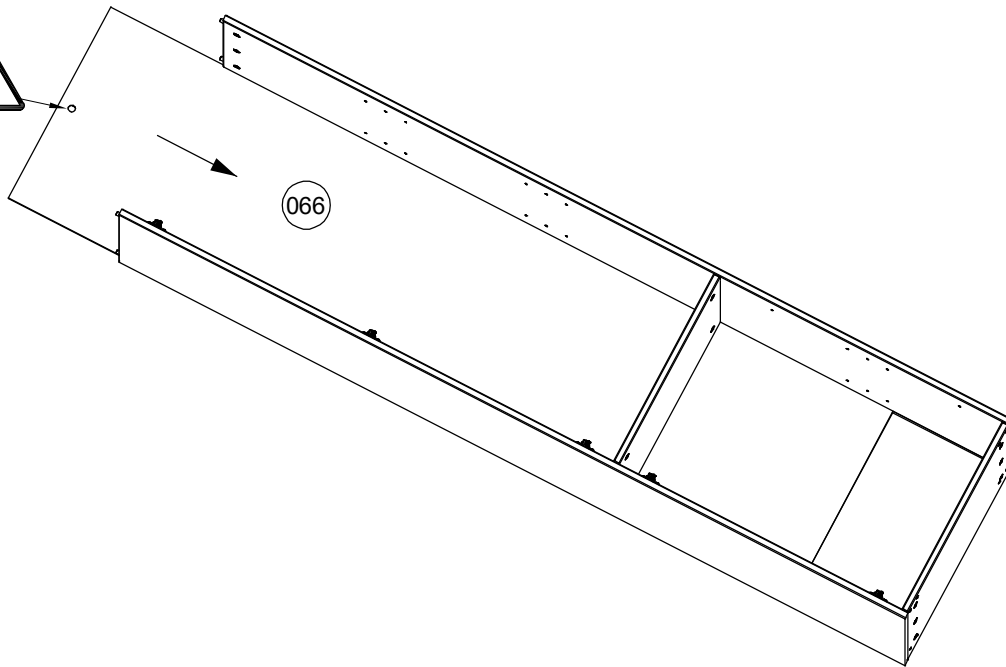

6

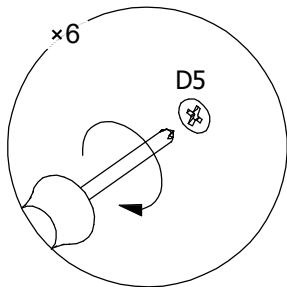
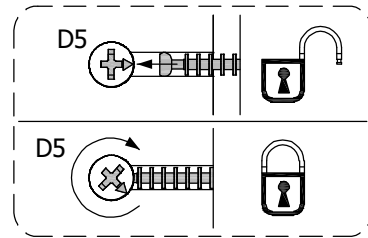
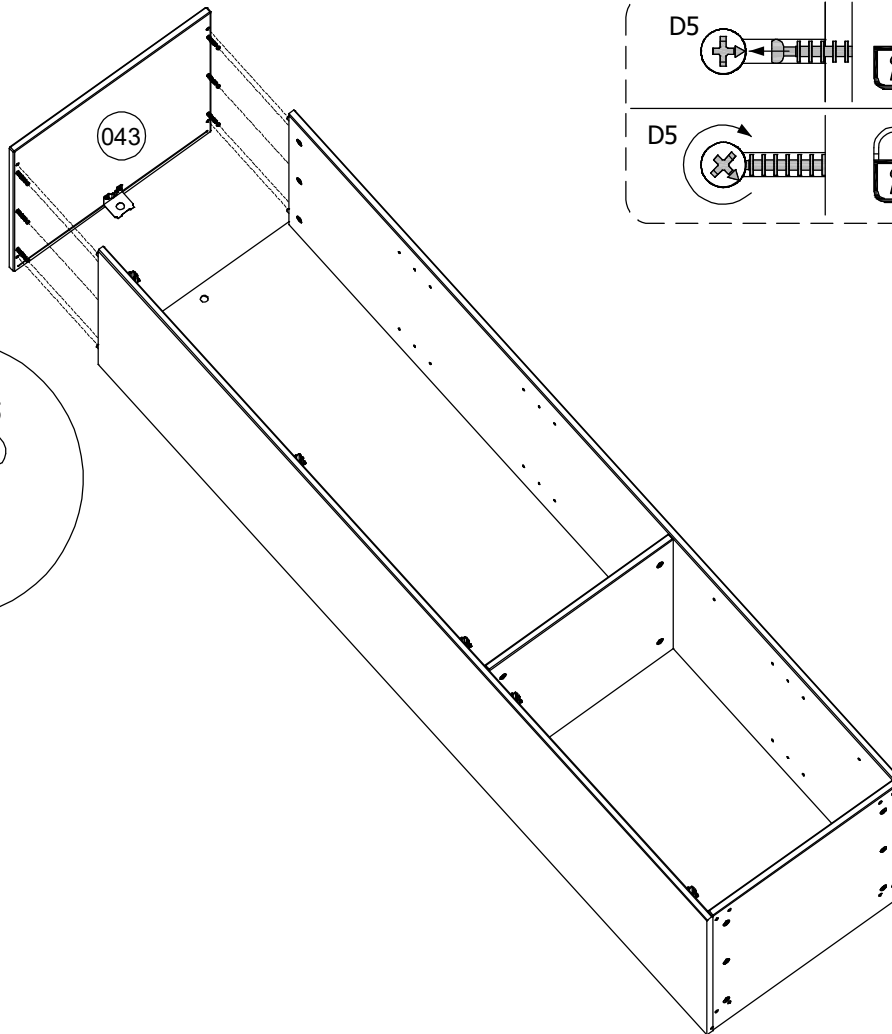

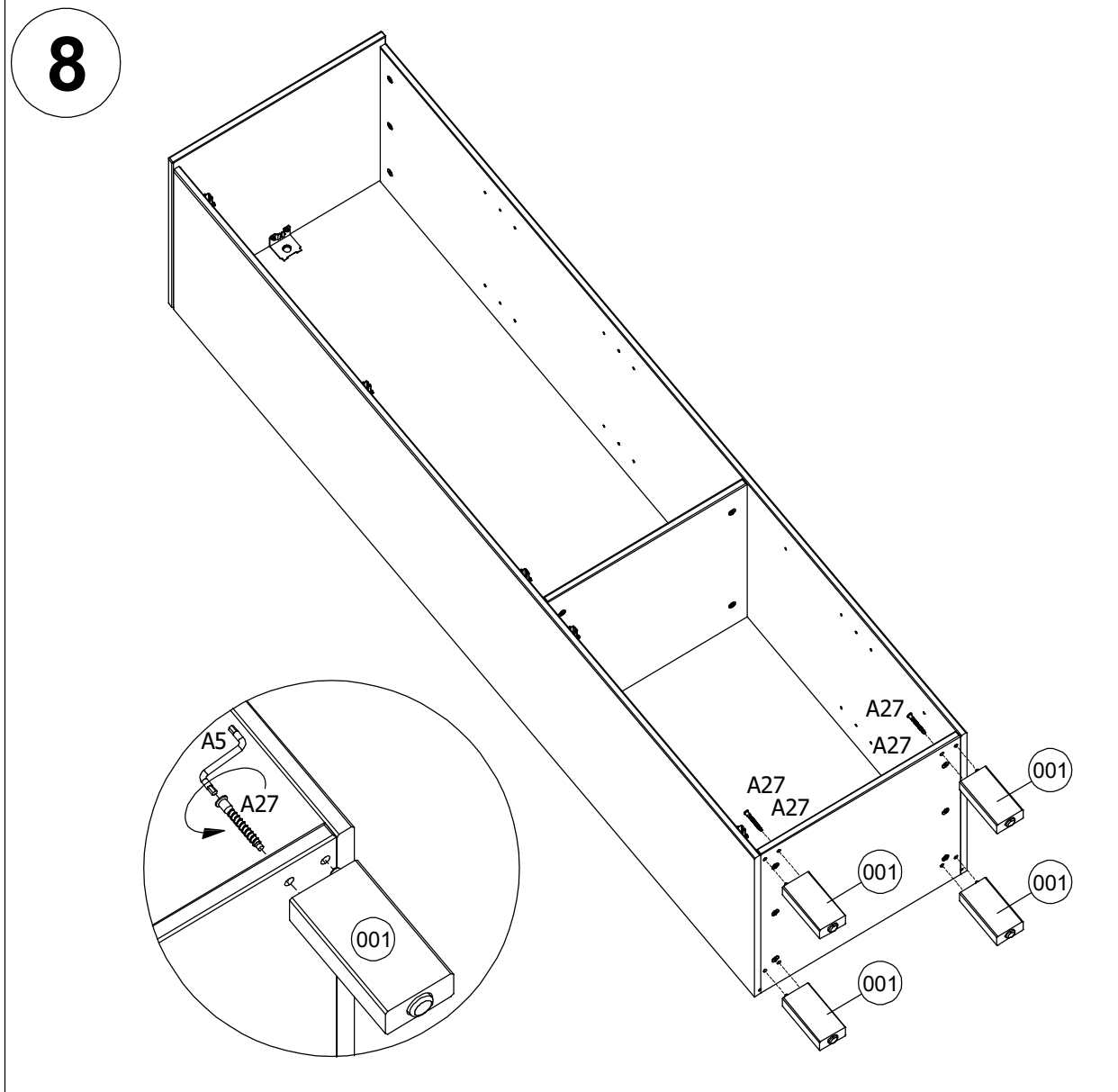
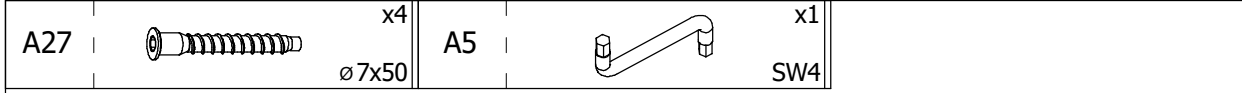
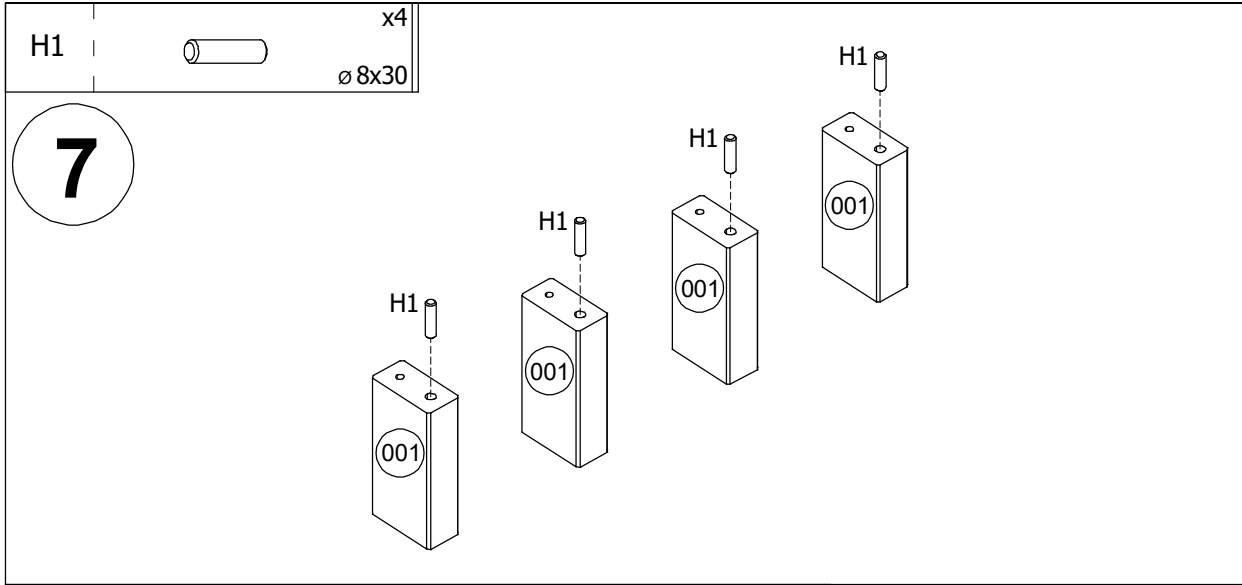

idp68245-1 idp68245-2

9

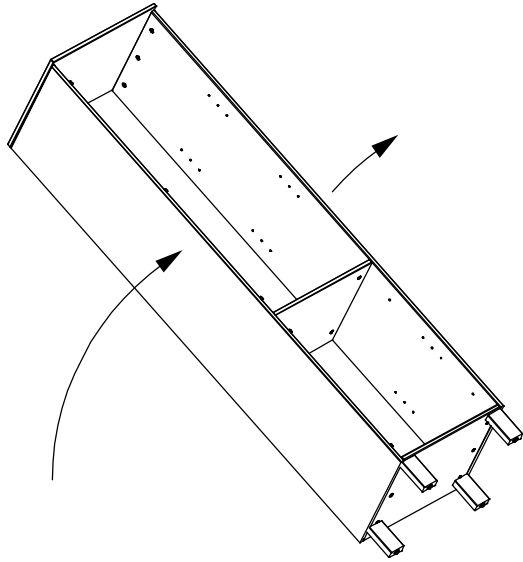
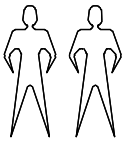

D36



x8

15x15x10

10

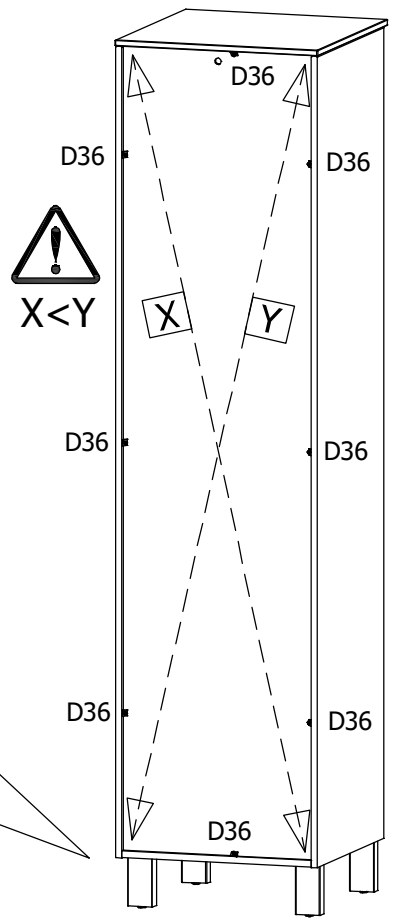
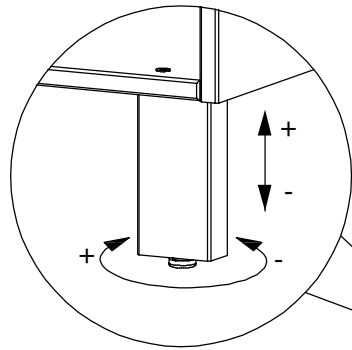
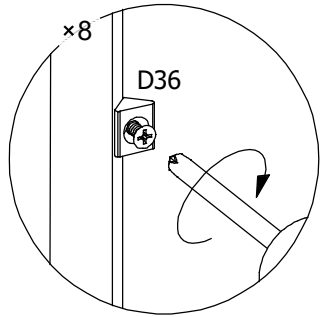
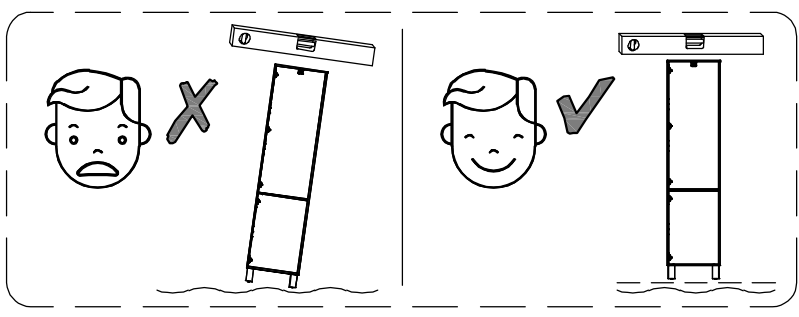
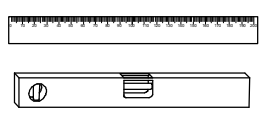

idp68245-1 idp68245-2

11

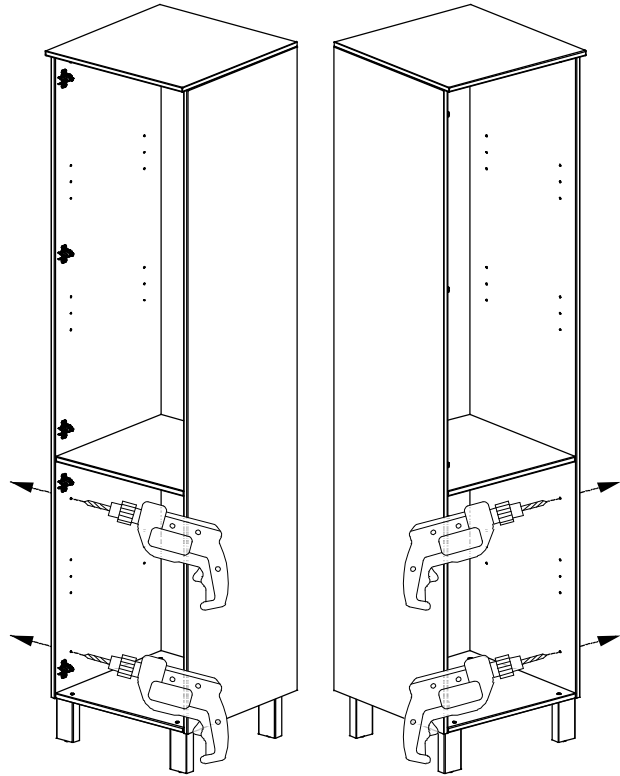
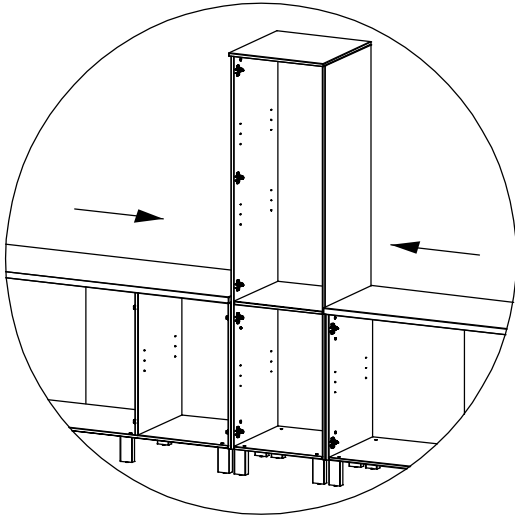
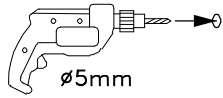

A278



x2

M4x15

A16





x2

M4x25

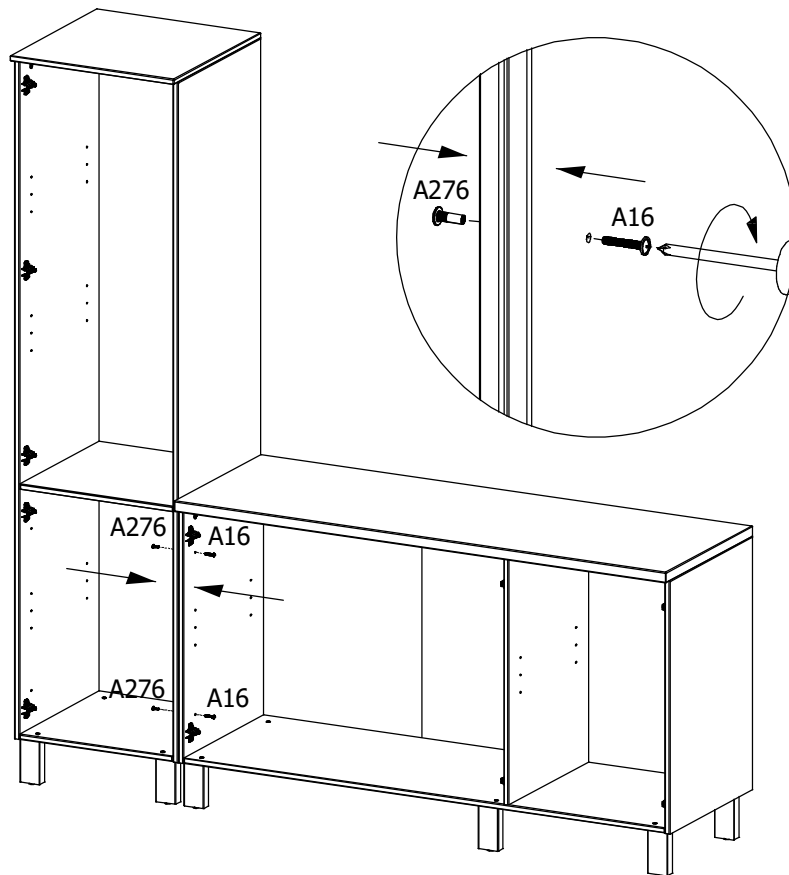
12



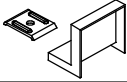

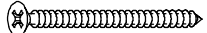
idp68245-1 idp68245-2

D31	 x1	H8	 x1	A69	 x1
			∅ 6x35		∅ 4x60

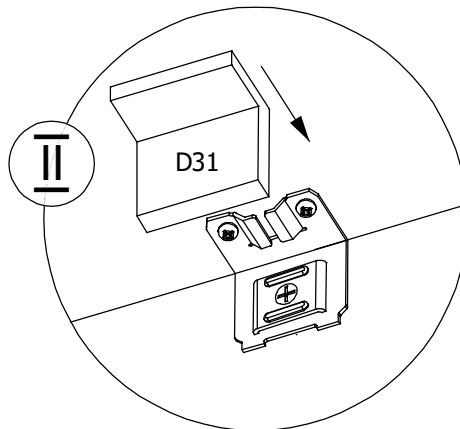
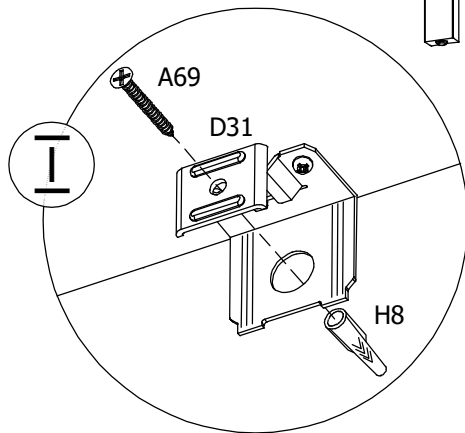
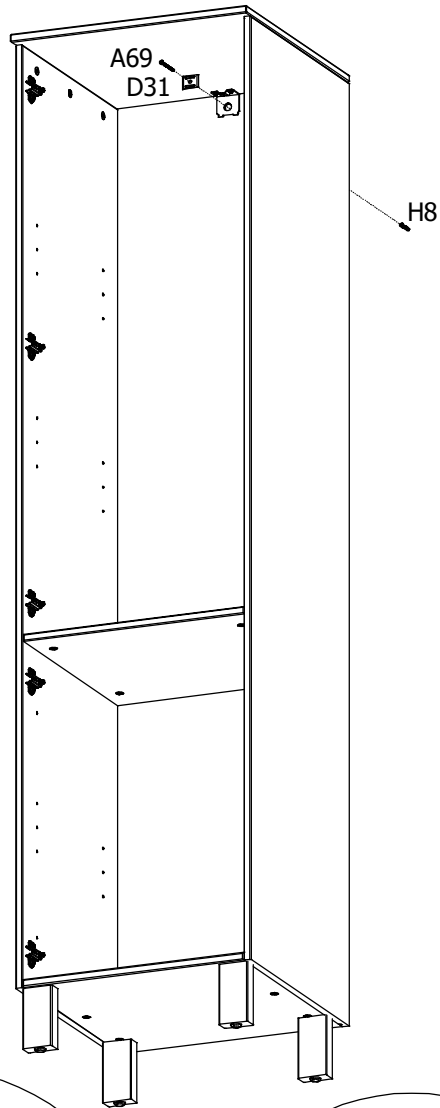
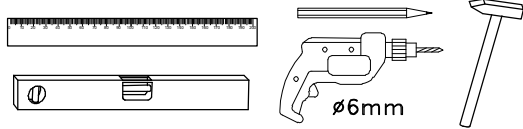
13



idp68245-1 idp68245-2

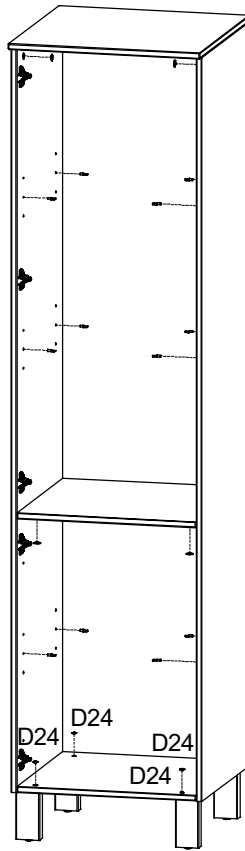
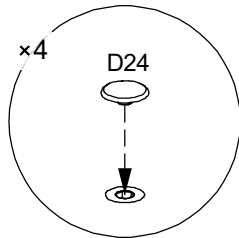
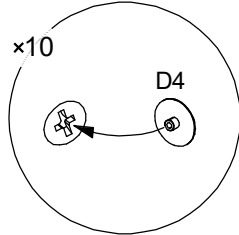
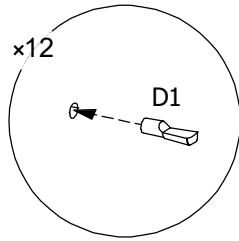

D1		x12 ø5	D4		x10 ø17	D24		x4 Ø13
----	---	-----------	----	---	------------	-----	---	-----------

14



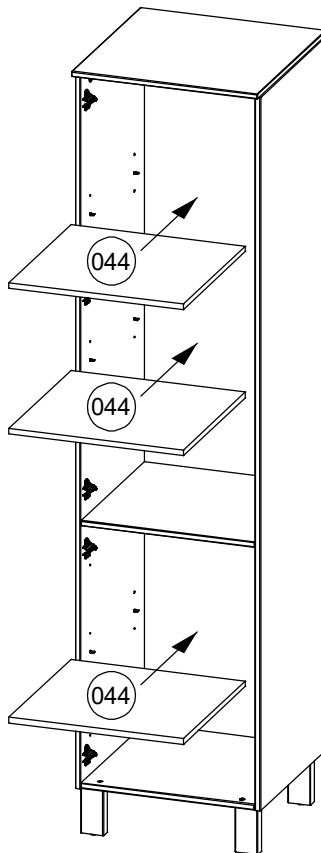
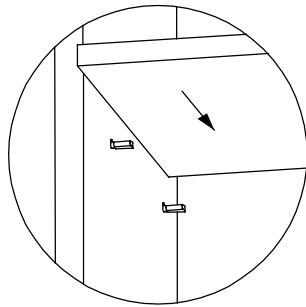

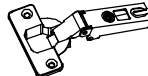
15

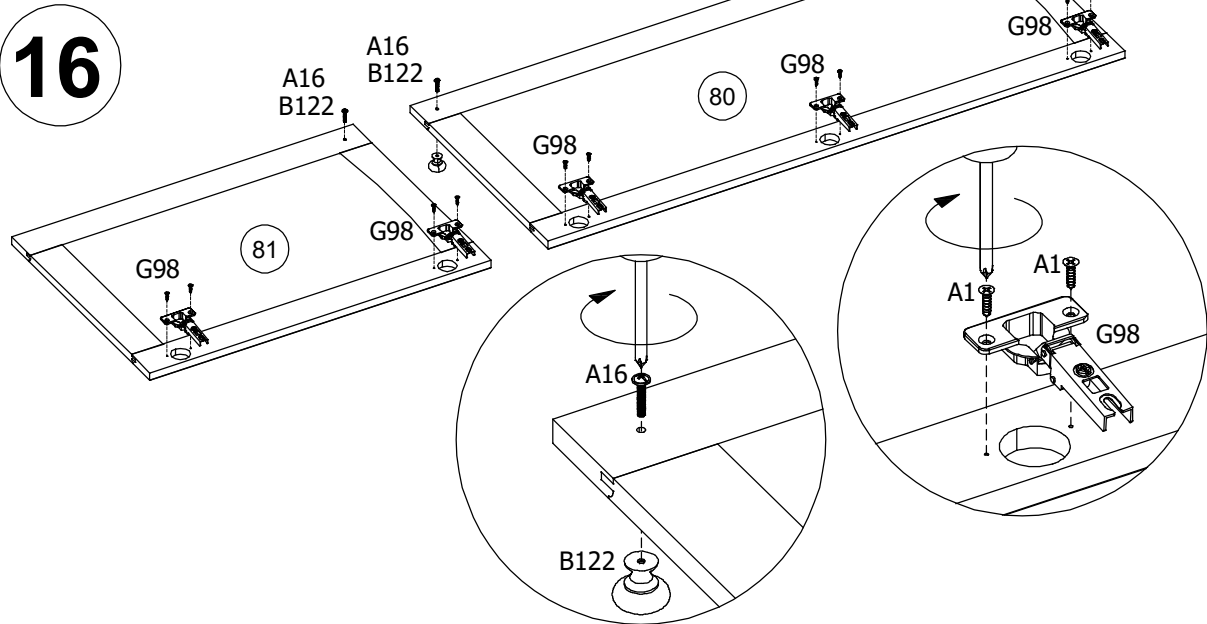

B122		x2	G98		x5	A1		x10
					ø35			ø 3,5x15

A16		x2
		M4x25



N3		x2
		Ø7x1,5

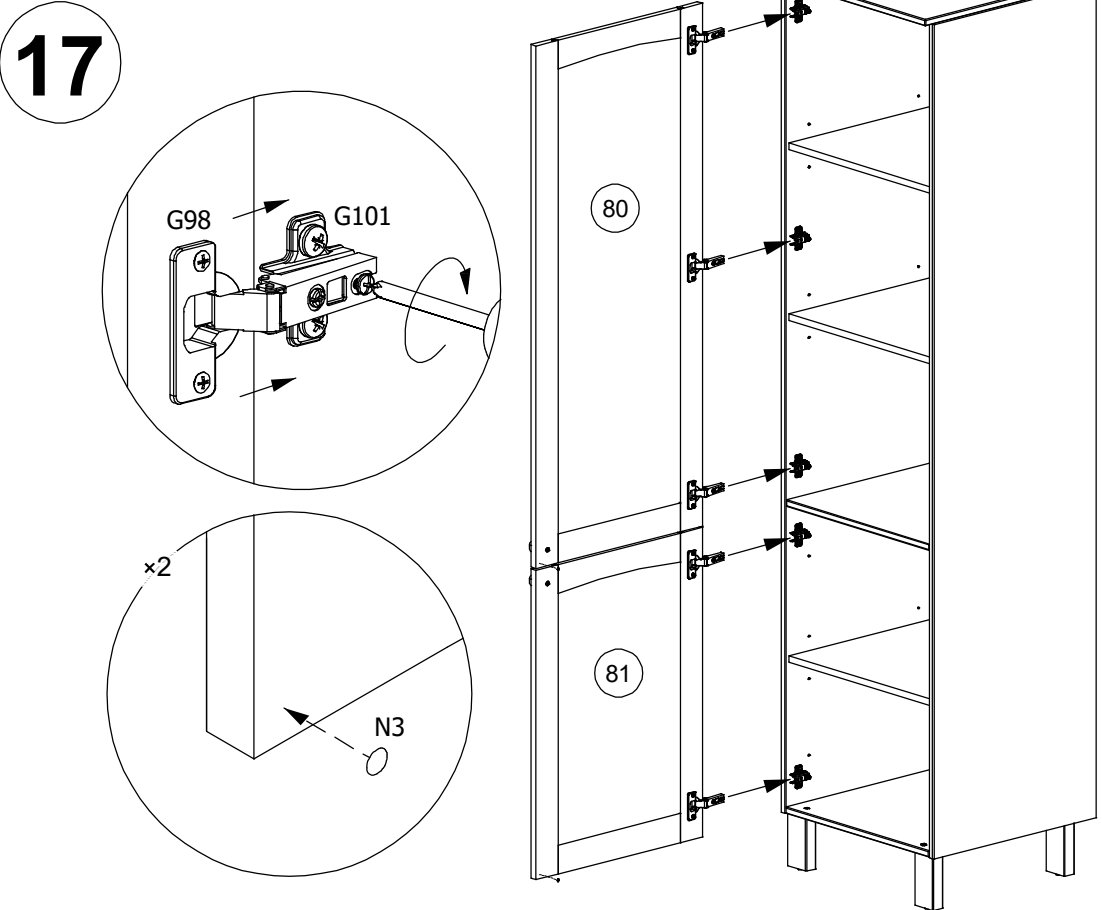

idp68245-1 idp68245-2

H8 

A69 
 ø4x60

 ø6mm

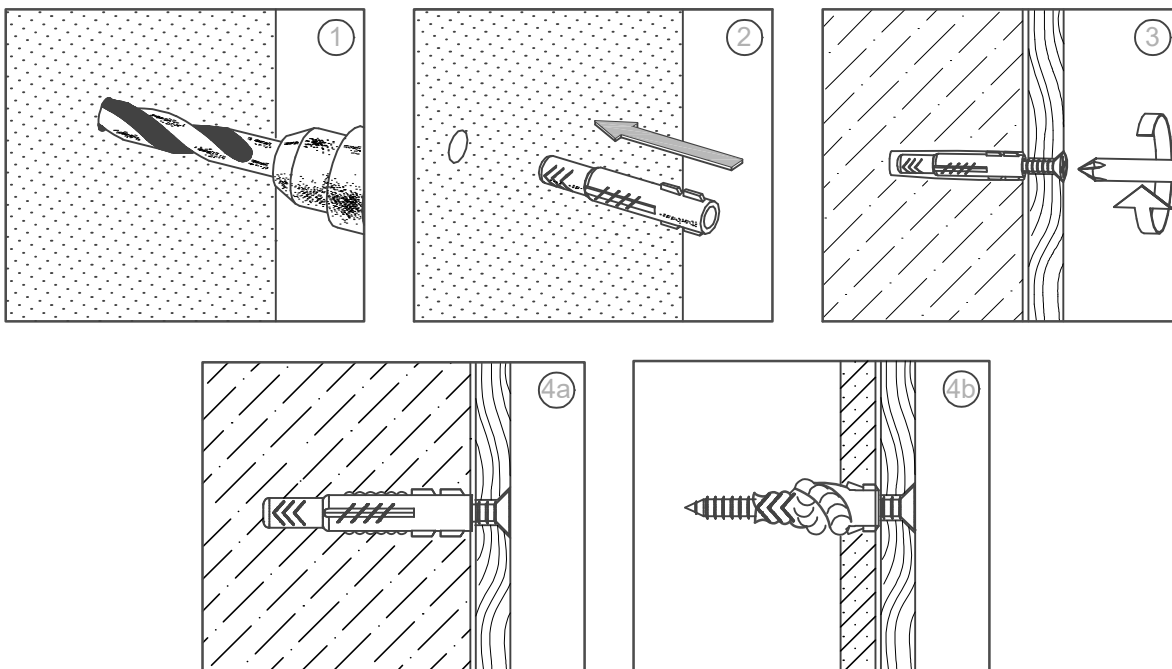

- D** **Achtung:** Die Befestigung des Möbelstückes an der Wand muss von einer fachkundigen Person vorgenommen werden, da für die Montage an die Wand angepasste Dübel erforderlich sind.
- GB** **Attention:** A qualified professional is required when mounting furniture to the wall since dowels corresponding to the wall are required for this.
- FR** **Attention :** La fixation du meuble contre le mur doit être effectuée par une personne compétente car, pour le montage mural, il faut utiliser des chevilles adaptées.
- IT** **Attenzione:** Il fissaggio del mobile alla parete deve essere eseguito da persone esperte, dato che occorrono tasselli adeguati.
- NL** **Opgelet:** een vakkundige persoon dient het meubelstuk aan de muur te bevestigen; voor de montage aan de muur zijn immers aangepaste pluggen vereist.
- PL** **Uwaga:** Mocowanie mebla do ściany mogą przeprowadzić wyłącznie wykwalifikowane osoby, z uwagi na zastosowanie odpowiednio dopasowanych kołków do rodzaju ściany.
- CZ** **Pozor:** Montáž nábytku na stěnu musí provést odborník, protože k montáži na stěnu jsou zapotřebí upravené hmoždinky.
- SK** **Pozor:** Upevnenie nábytku na stenu musí vykonať odborník, nakoľko sú pre montáž na stenu potrebné vhodné hmoždinky.
- HU** **Figyelem:** A bútorelemek falra rögzítését szakembernek kell végeznie, mert a rögzítéshez megfelelő tiplit kell használni.
- RO** **Atenție:** Fixarea la perete a piesei de mobilier se realizează numai de către personal competent, deoarece montajul de perete necesită dibluri adecvate.
- TR** **Dikkat:** Mobilya parçasının duvara sabitlenmesi, duvar montajı için özel uyarlanmış dübeller gerektirdiğinden bu iş sadece bu konuda uzman bir kişi tarafından gerçekleştirilmelidir.
- RU** **Внимание:** Поскольку для монтажа на стене необходимо использовать специальные дюбели, мебель должна быть закреплена на стене квалифицированным персоналом.
- LV** **Uzmanību:** Mēbeles montāžai pie sienas paredzēts izmantot speciālus dībeļus. Ietecams šo darbu veikt kvalificētam darbiniekam.

- ⒸZ) Úprava dverí
- Ⓓ) Das Richten einer Türe
- Ⓕ) Réglage d'une porte.
- ⒽU) Beállítás egy ajtó
- Ⓘ) Regolare una porta
- ⒻV) Durvju regulēšana
- ⒼNL) Instellen van een deur
- ⒼPL) Regulacja drzwi
- ⒼRO) Reglarea o ușă
- ⒼRU) Регулировка Дверей
- ⒼSK) Úprava dverí
- ⒼTR) Bir kapı ayarlama
- ⒼUK) Adjusting a door
- ⒼFIN) Oven säätö

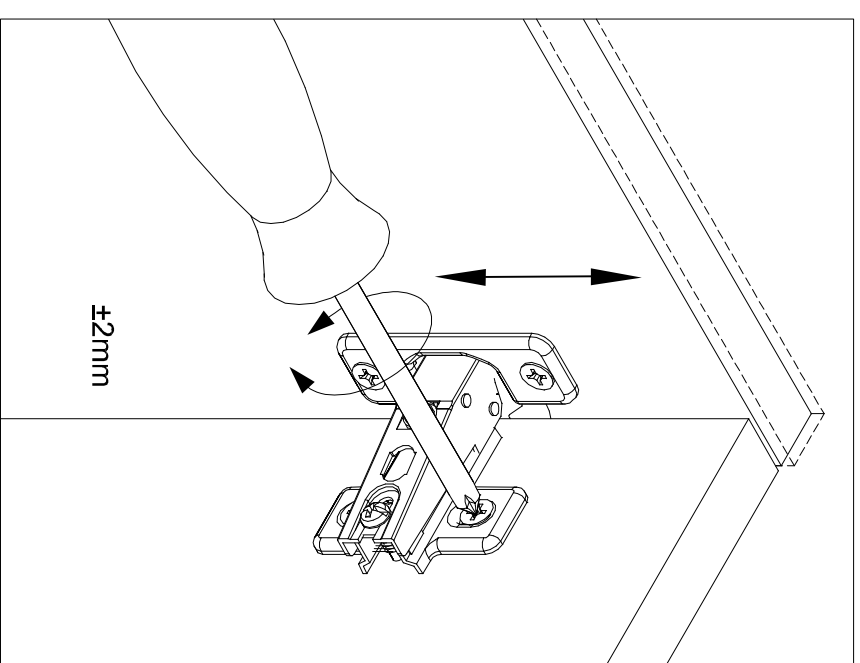
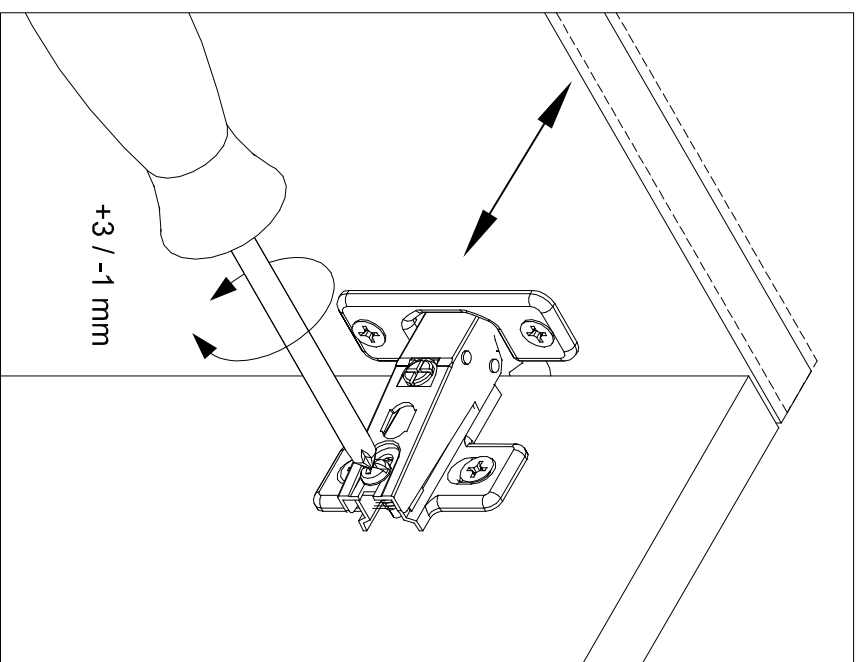
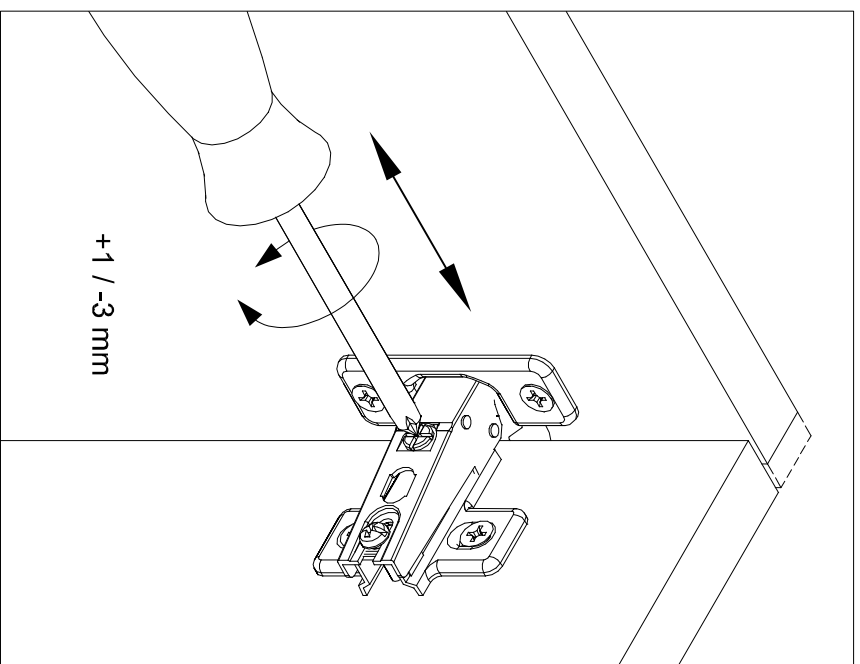





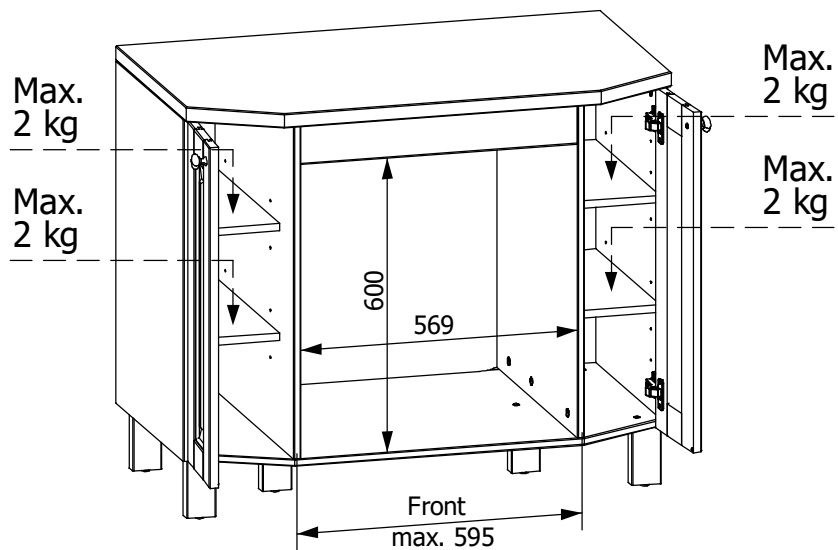
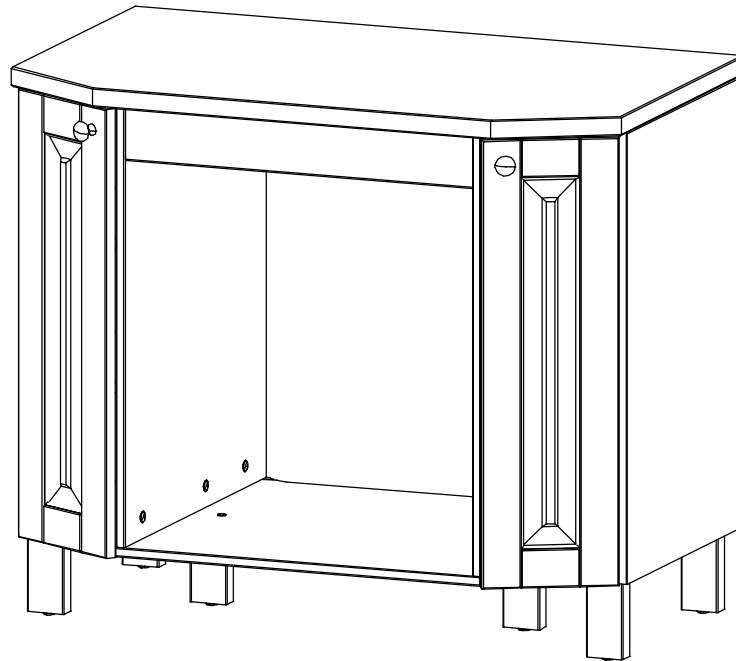
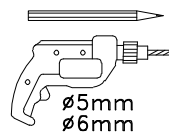
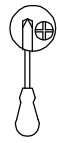
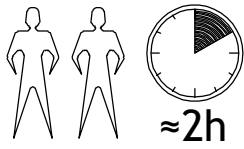



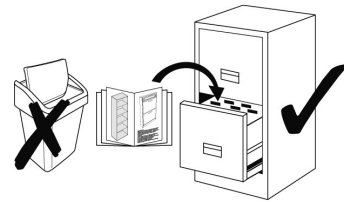
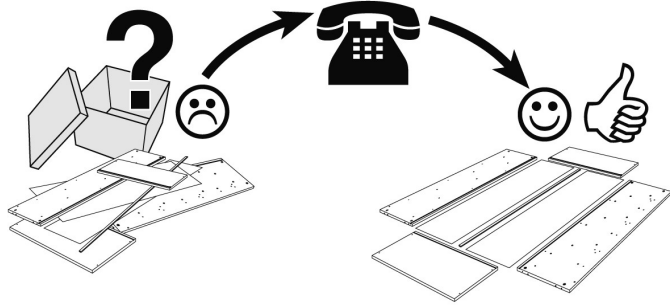





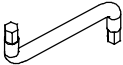

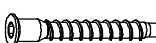

Art. 75855429 50321914

LKZ 75007



idp68241-1 idp68241-2

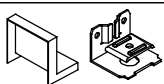

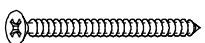
Service • Assistenza • Dienstverlening • Serwis Servis • Szerviz • Сервисная служба	
Name • Nom • Nome • Naam Nazwa • Jméno • Názov • Név Denumire • Isim • Название	
Nr • No • N • Номер • Č • Sz	
Tur • Туре • Тір • Тірус • Тіро Тип	
	
	

					H1		x24 ø 8x30
D5	 x26 ø 15x12,5	D4	 x20 ø 17	D2	 x26 ø 5/11x34		
A5	 x1 SW4	D24	 x6 Ø13	A27	 x6 ø 7x50		
D36	 x12 15x15x10	G144	 x4 ø 35	A1	 x16 ø 3,5x15		
B122	 x2	A278	 x2 M4x15	A16	 x4 M4x25		
N3	 x2 Ø7x1,5	D1	 x16 ø 5	A10	 x4 ø 4x16		
D31	 x2	H8	 x2 ø 6x35	A69	 x2 ø 4x60		

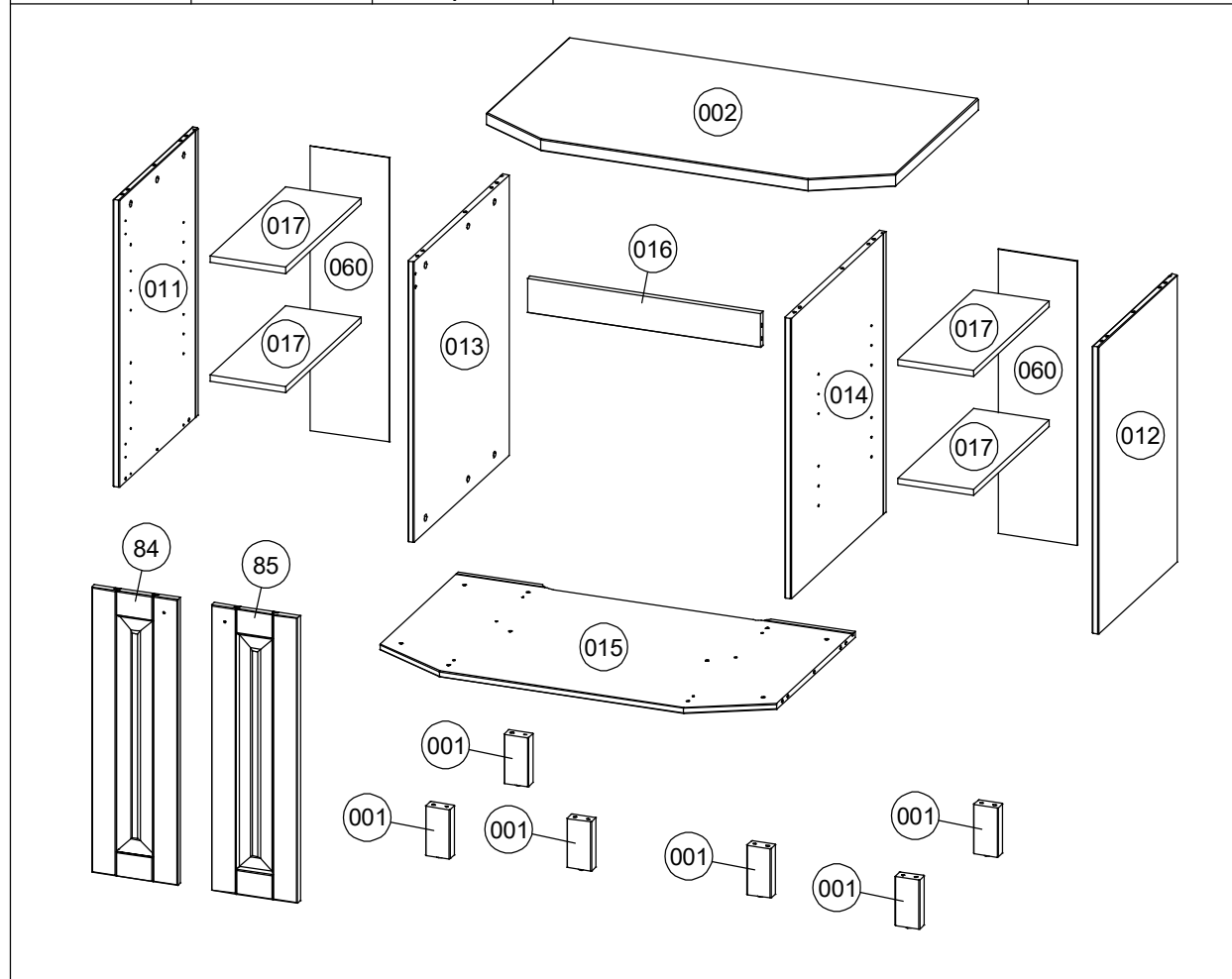
Teil Nr. Pièces Nr. Pieces Nr. Часть Ном. Kawalek Nr. Parça No Kusù Nr. Kusov Nr. Pezzi Nr. Nr piese. Darab száma. Stukken Nr. Kārtas Nr.	Anzahl Quantité Quantity Количество Ilość Miktar Množství Množstvo Quantità Cantitatea Mennyiség Hoeveelheid Skaitis	Kasten Nr. Colli Nr. Colli Nr. Коробка Ном. Polu Nr. Kutusu Nr. Kolonka Č. Počet balení Colli Nr. Nu pachete Colli száma. Colli Nr. Kastes Nr.	Maß, mm Dimensions, mm Dimensions, mm Размеры, mm Wymiary, mm Boyutlar, mm Rozměry, mm Rozmery, mm Dimensioni, mm Dimensiuni, mm Méretek, mm Afmetingen, mm Izmēri, mm	✓
001	6	1 / 2	120 x 60 x 30	
002	1	2 / 2	999 x 600 x 30	
011	1	1 / 2	700 x 476 x 15	
012	1	1 / 2	700 x 476 x 15	
013	1	1 / 2	684 x 574 x 15	
014	1	1 / 2	684 x 574 x 15	
015	1	2 / 2	968 x 576 x 15	
016	1	1 / 2	569 x 84 x 15	
017	4	1 / 2	184 x 456 x 15	
060	2	1 / 2	693 x 193 x 3	
84	1	1 / 2	696 x 210 x 18	
85	1	1 / 2	696 x 210 x 18	





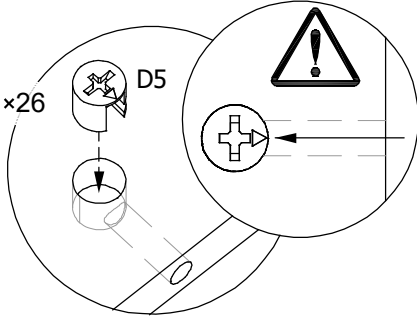
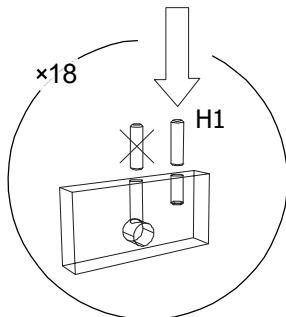
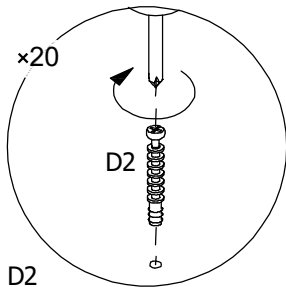
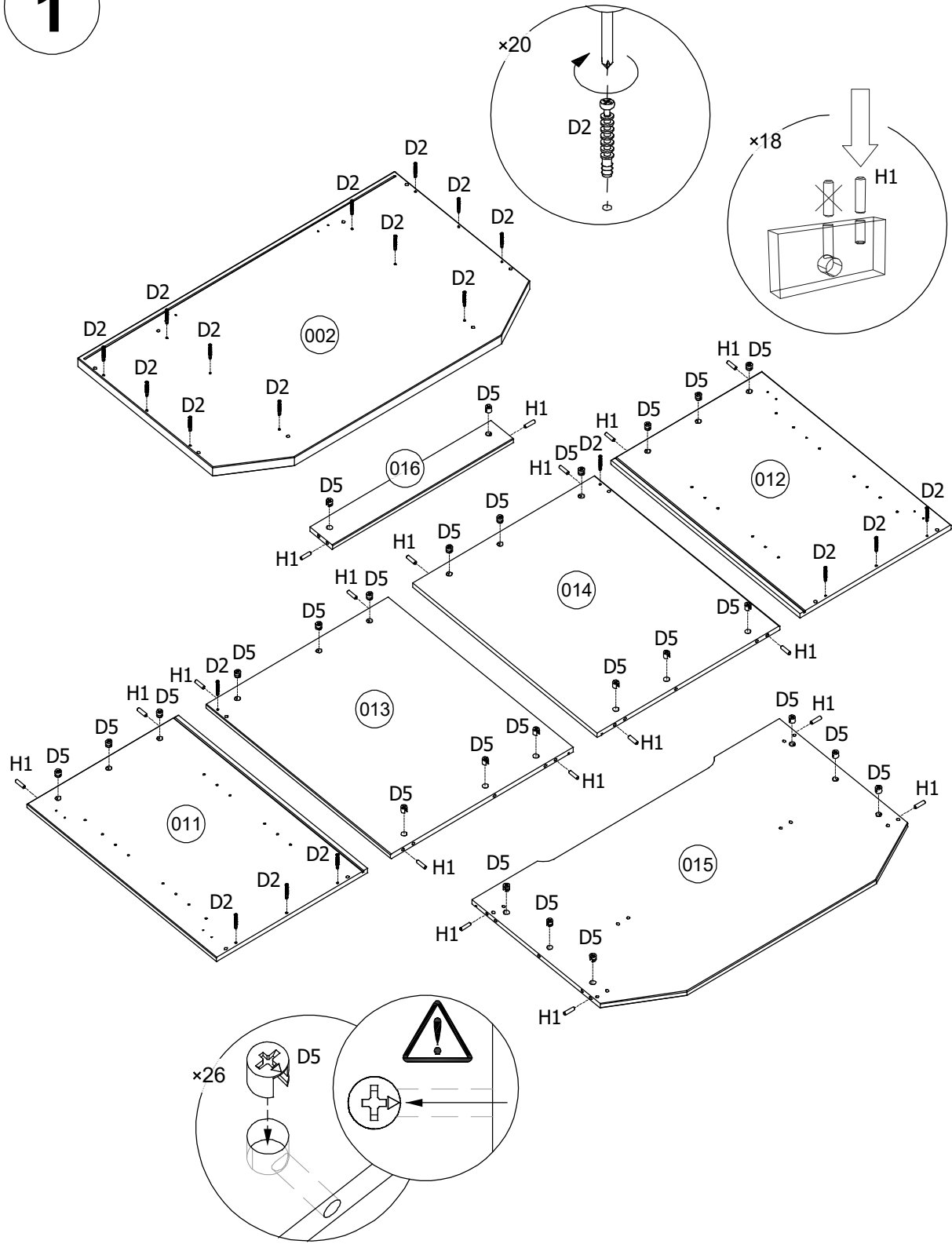

idp68241-1 idp68241-2

H1		x18 ø 8x30	D2		x20 ø 5/11x34	D5		x26 ø 15x12,5
----	---	---------------	----	---	------------------	----	---	------------------

1

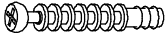

idp68241-1 idp68241-2

D31		x2	A10		x4 ø4x16	D2		x6 ø 5/11x34
G144		x4	A1		x8 ø 3,5x15			

2

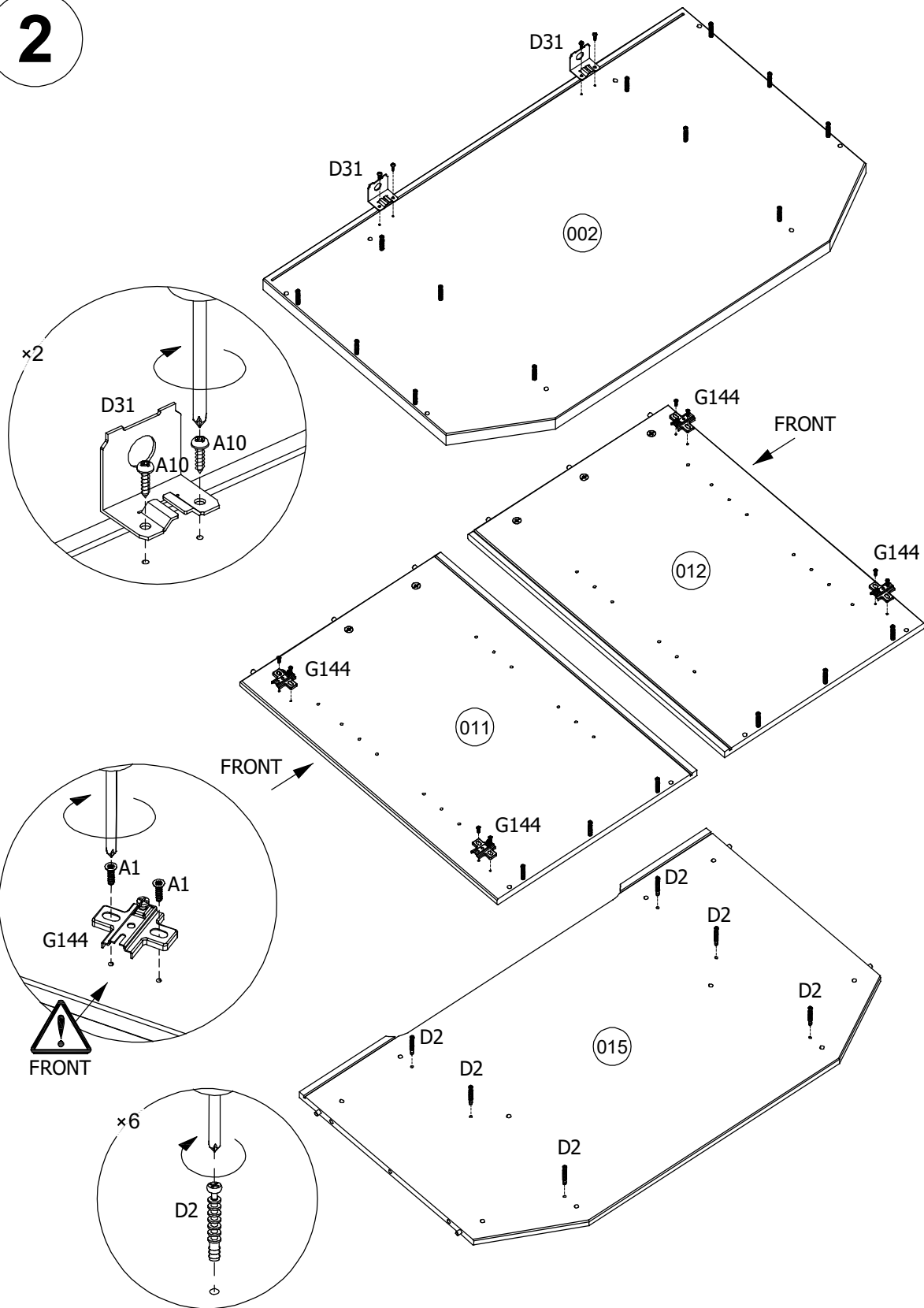

idp68241-1 idp68241-2

3

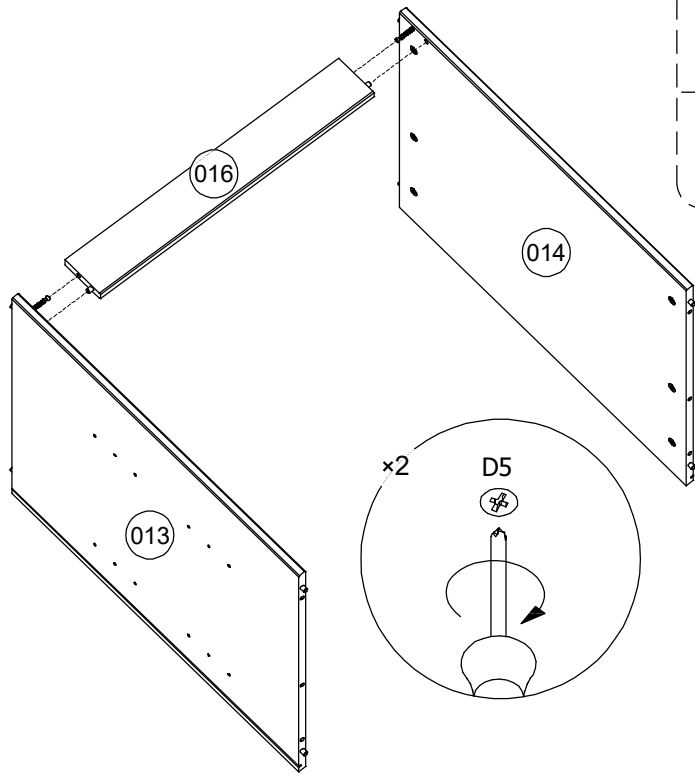

4

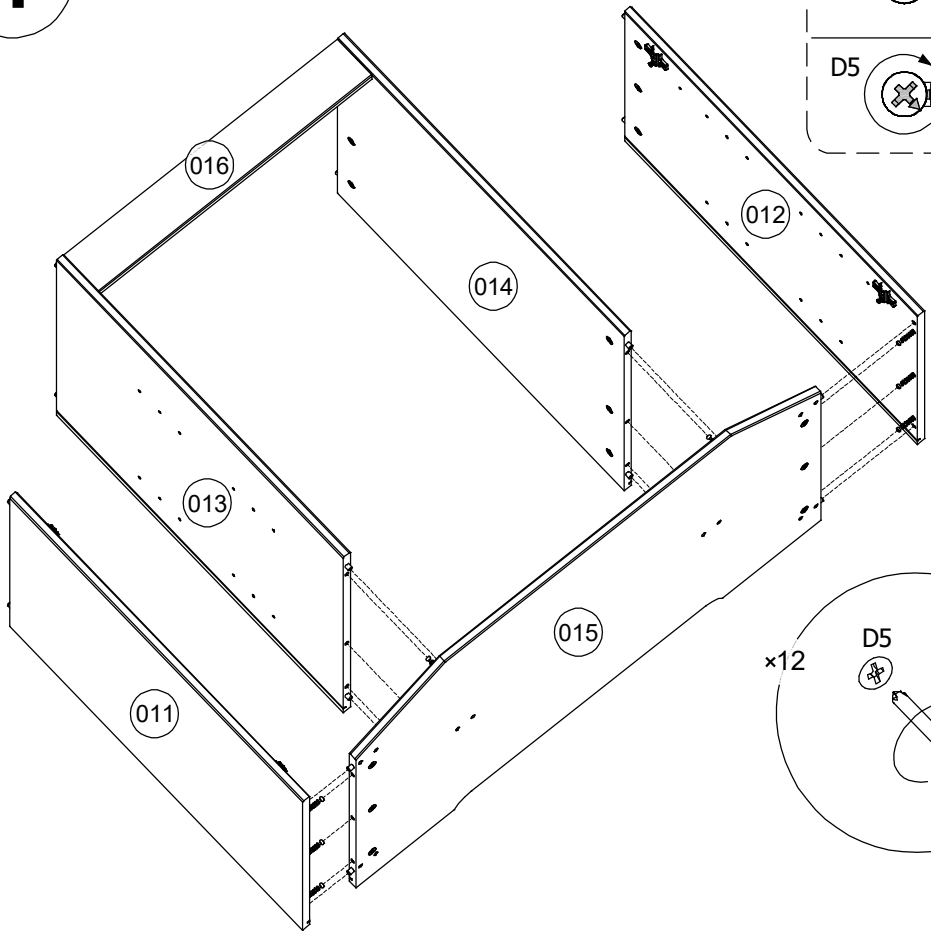

idp68241-1 idp68241-2

5

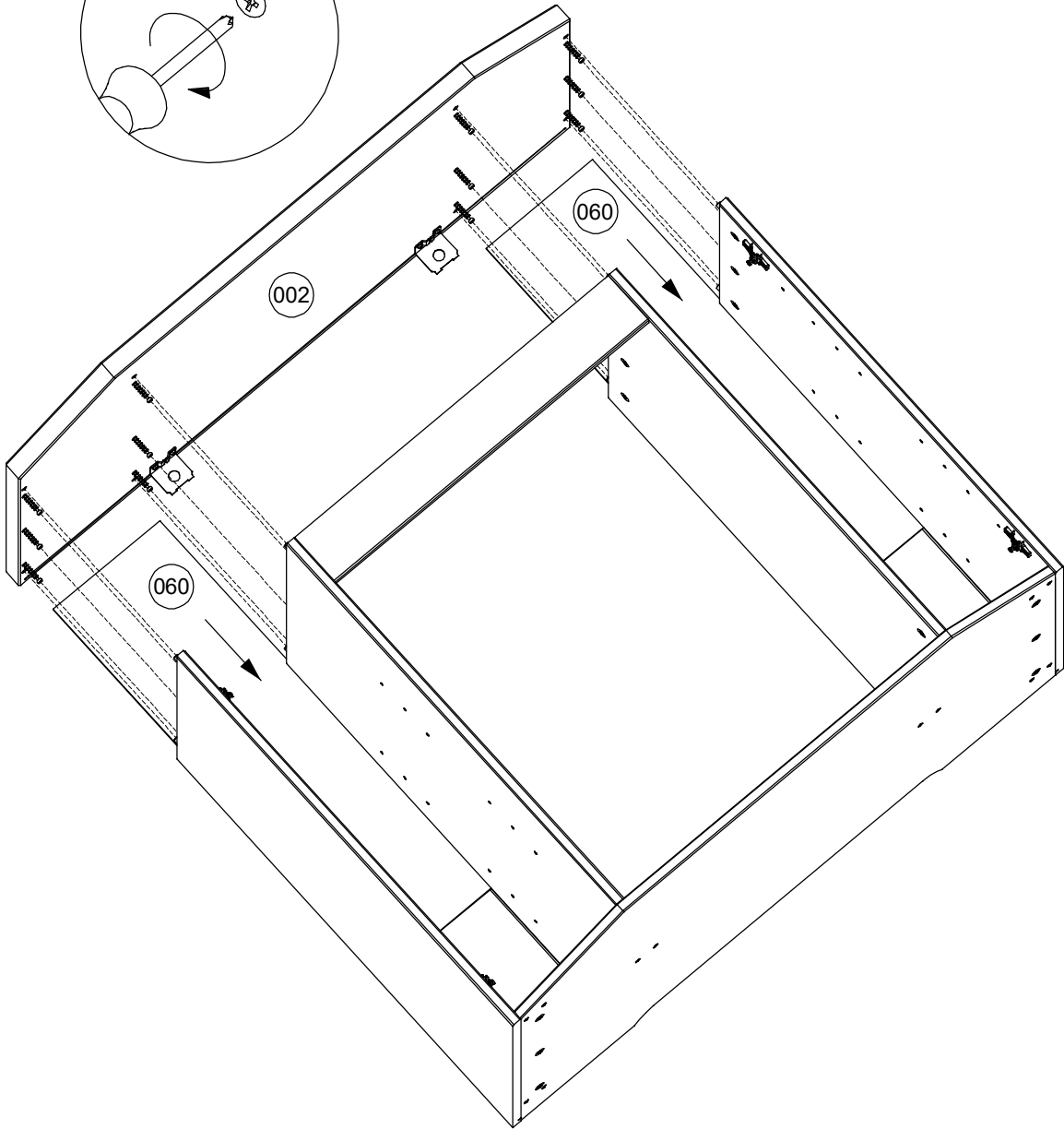
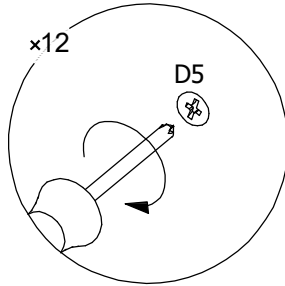
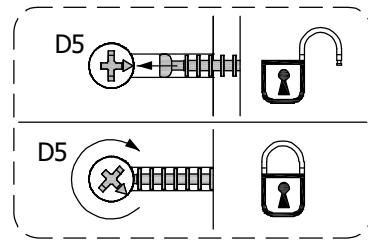

idp68241-1 idp68241-2

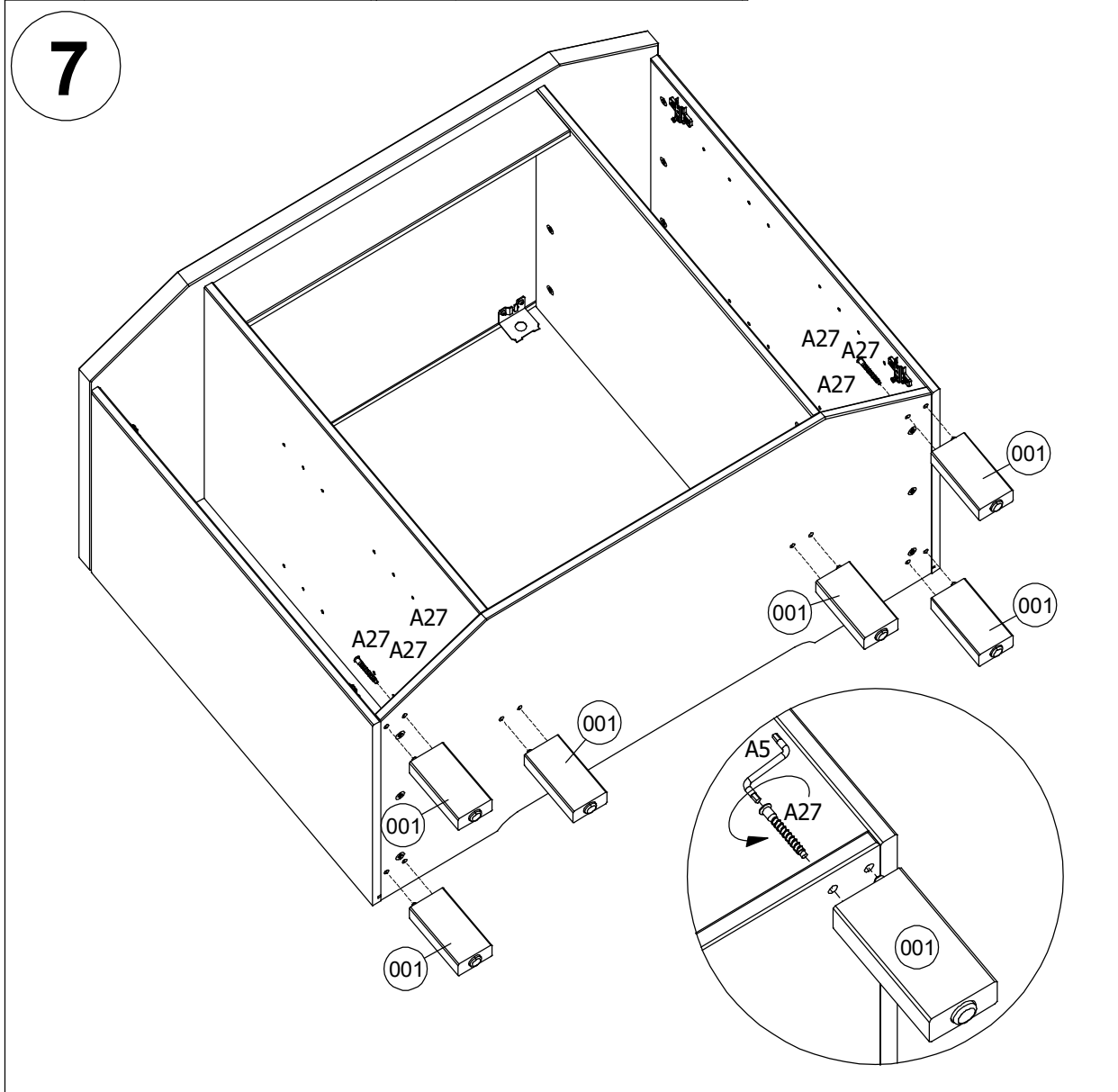
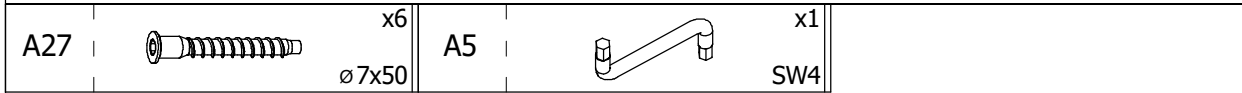
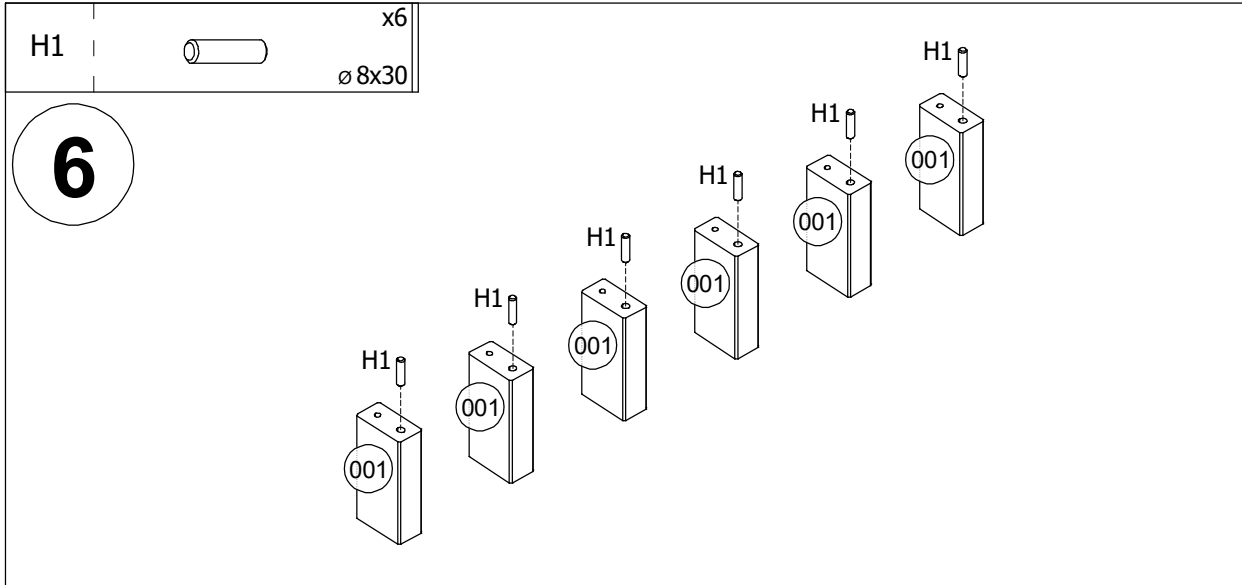

idp68241-1 idp68241-2

8

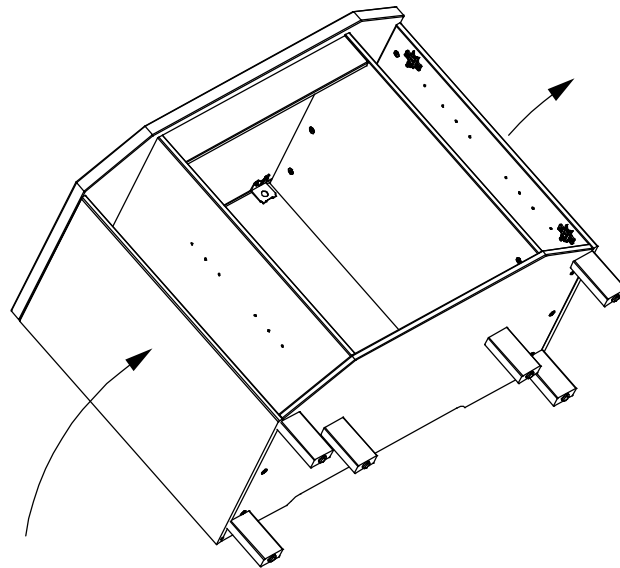
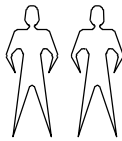

D36



x12

15x15x10

9

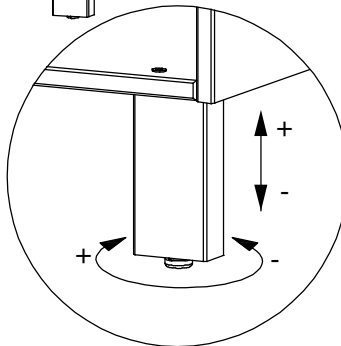
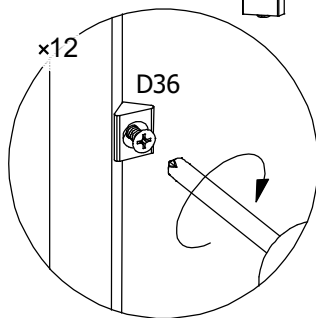
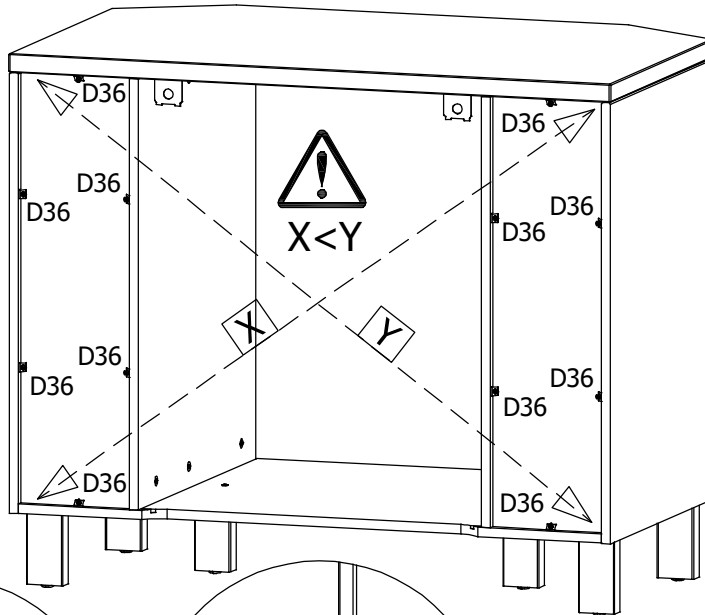
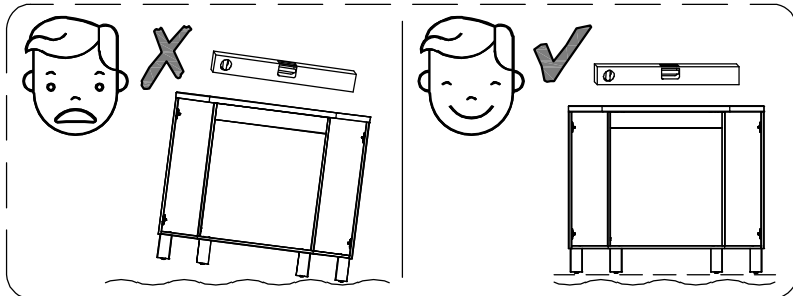

idp68241-1 idp68241-2

10

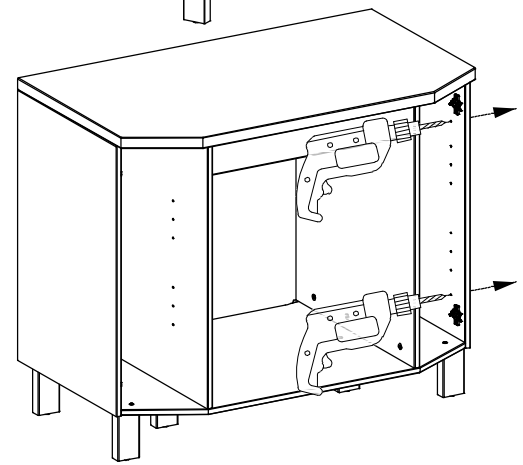
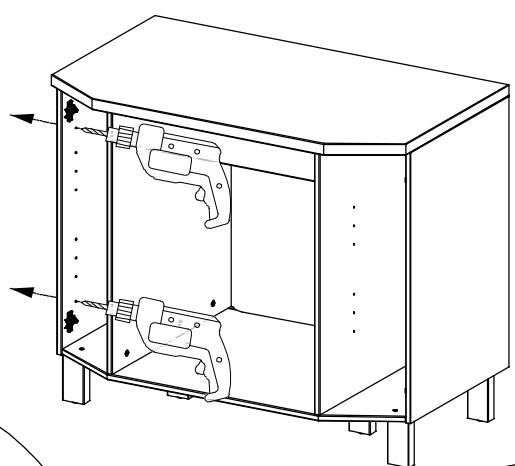
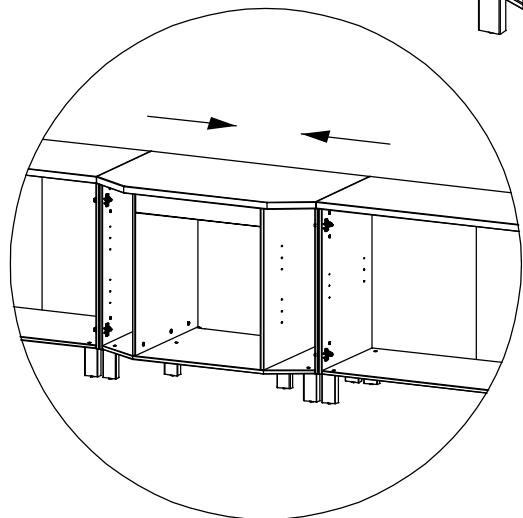
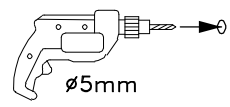

A278



x2

M4x15

A16



x2

M4x25

11

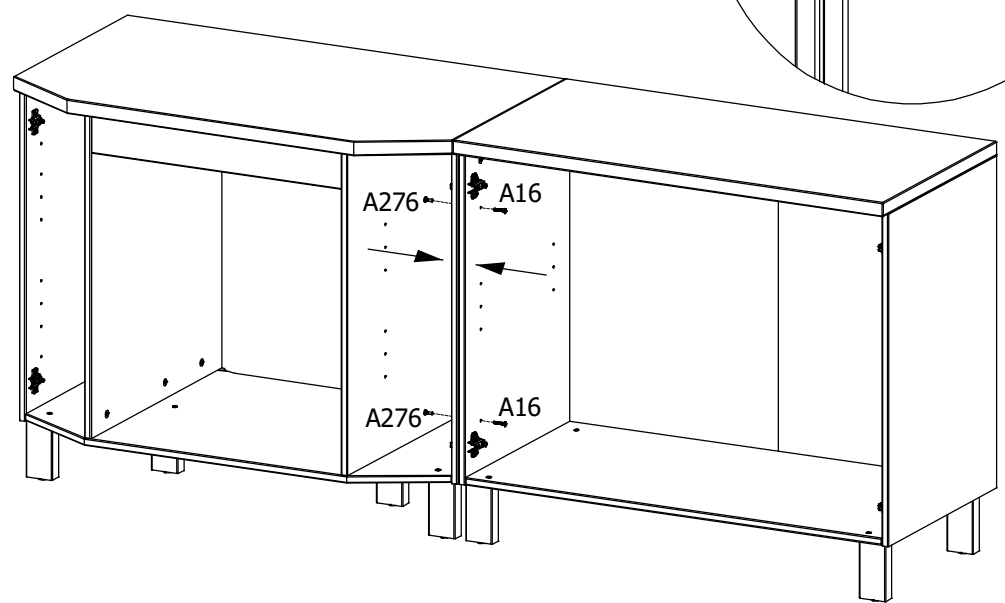
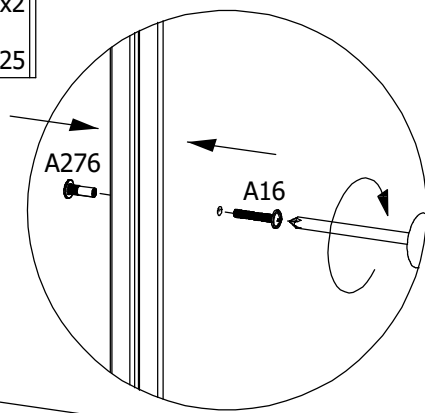

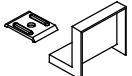
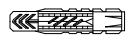
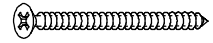

idp68241-1 idp68241-2

D31	 x2	H8	 x2 ø 6x35	A69	 x2 ø 4x60
-----	--	----	--	-----	--

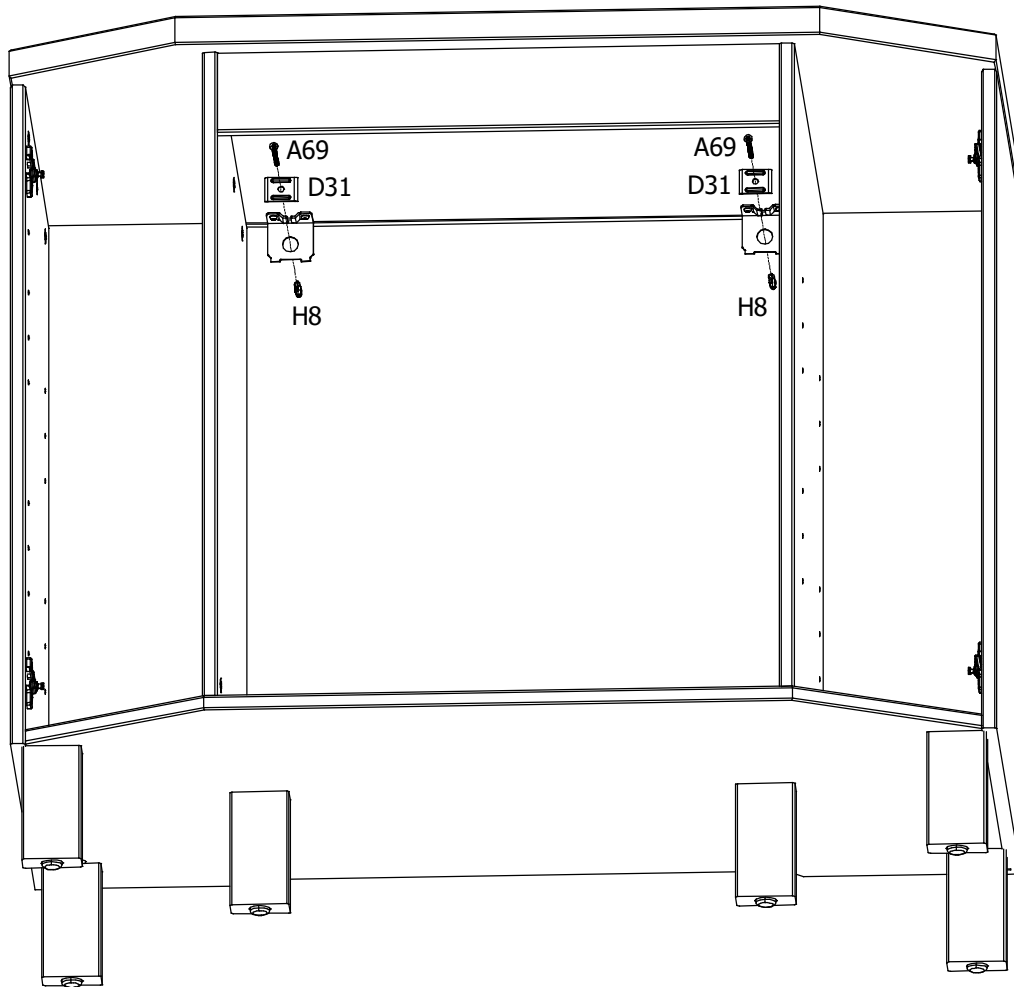
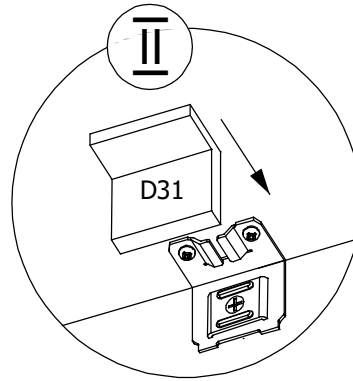
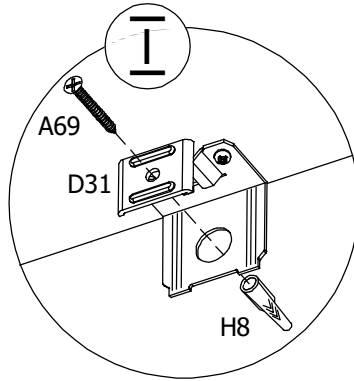
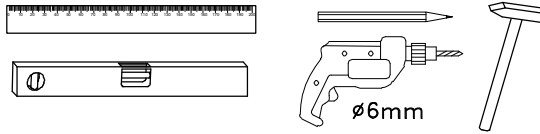
12



idp68241-1 idp68241-2

D1		x16 ø5	D4		x20 ø17	D24		x6 Ø13
----	---	-----------	----	---	------------	-----	---	-----------



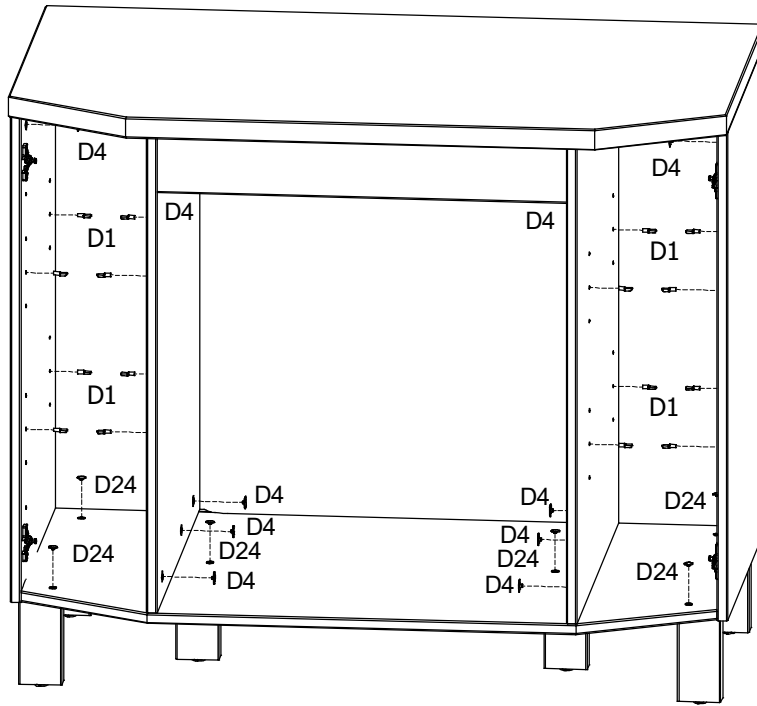
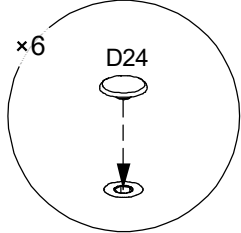
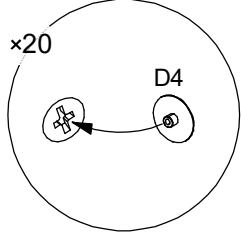
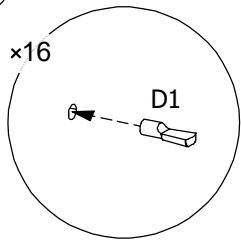

13

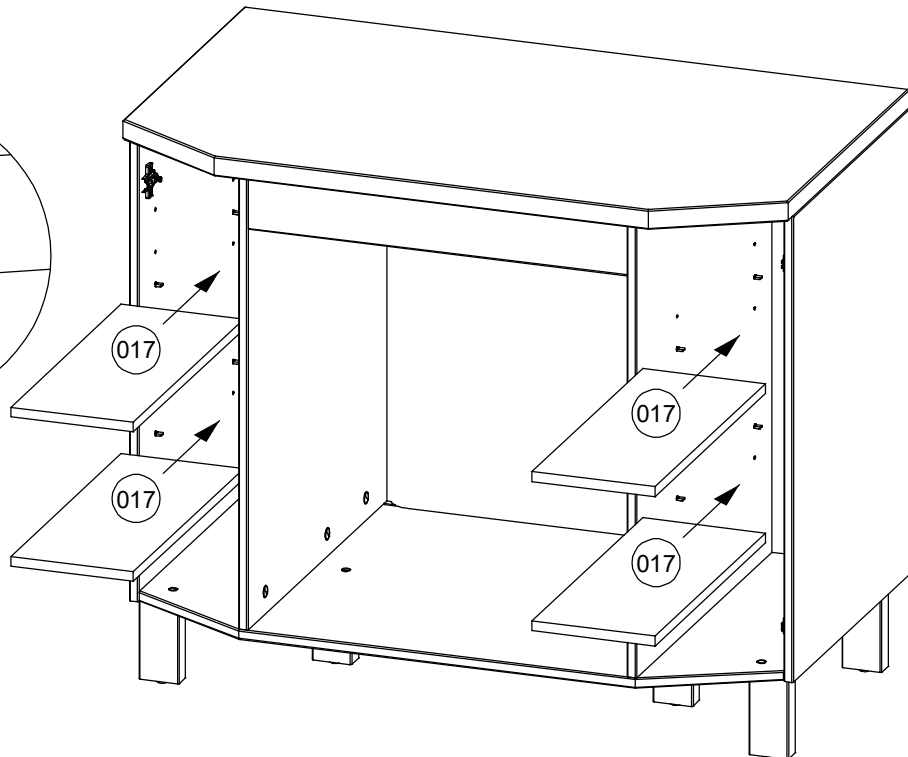
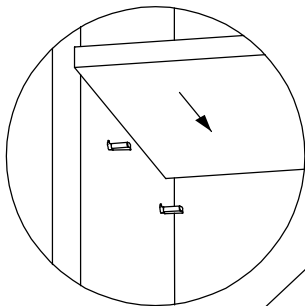

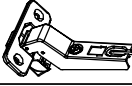

14

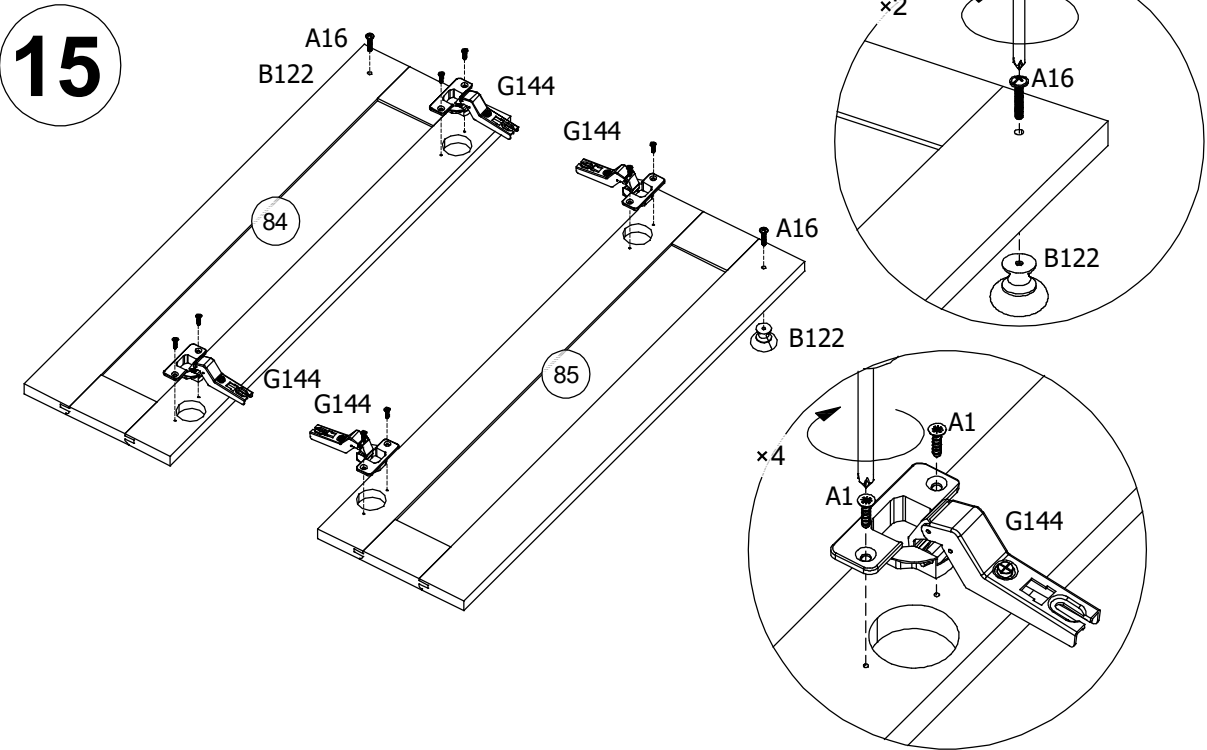

idp68241-1 idp68241-2

G144		x4 ø35	B122		x2	A16		x2 M4x25
A1		x8 ø 3,5x15						



N3		x2 Ø7x1,5
----	---	--------------

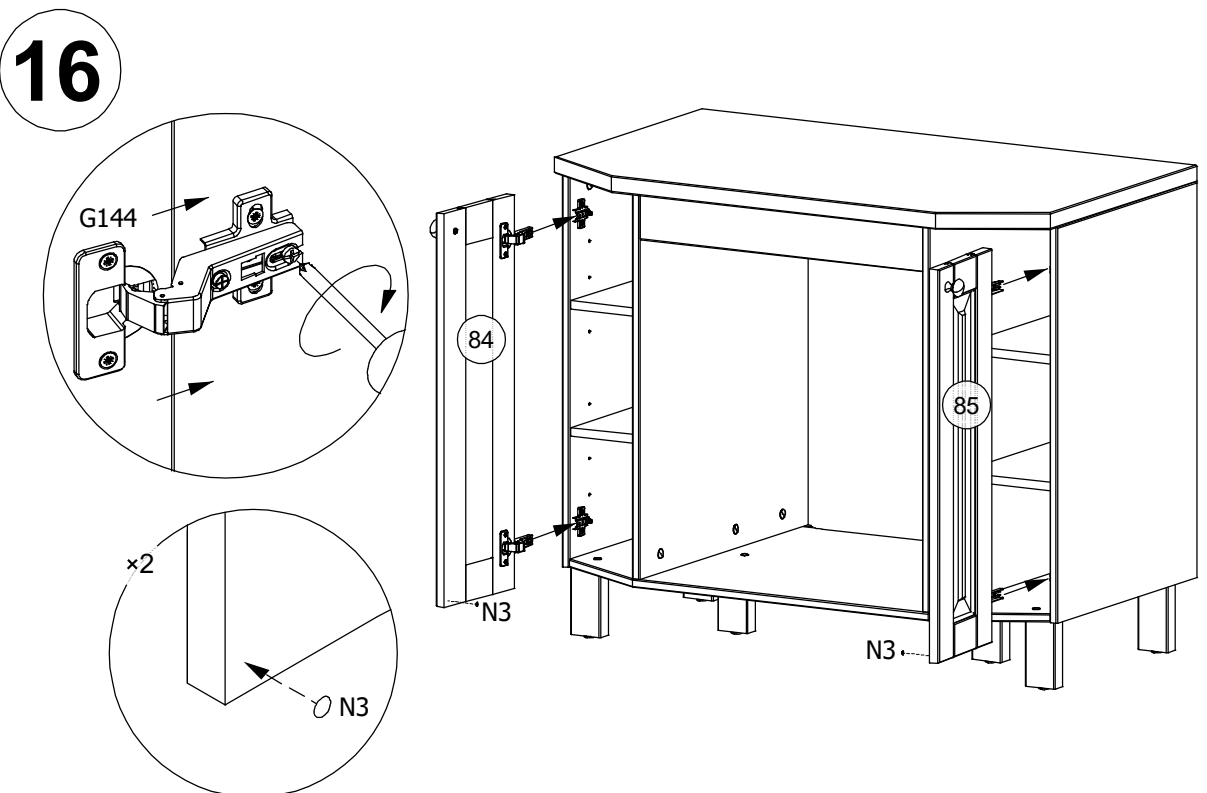

idp68241-1 idp68241-2

H8 

A69 
 ø4x60

 ø6mm

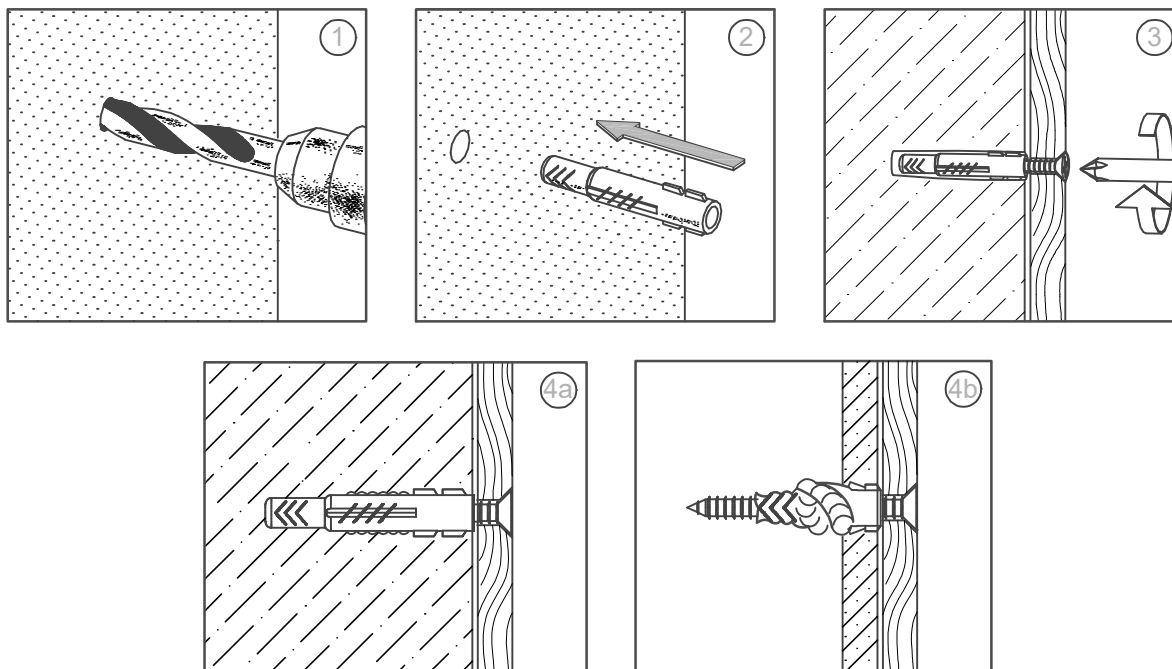

- D** **Achtung:** Die Befestigung des Möbelstückes an der Wand muss von einer fachkundigen Person vorgenommen werden, da für die Montage an die Wand angepasste Dübel erforderlich sind.
- GB** **Attention:** A qualified professional is required when mounting furniture to the wall since dowels corresponding to the wall are required for this.
- FR** **Attention :** La fixation du meuble contre le mur doit être effectuée par une personne compétente car, pour le montage mural, il faut utiliser des chevilles adaptées.
- IT** **Attenzione:** Il fissaggio del mobile alla parete deve essere eseguito da persone esperte, dato che occorrono tasselli adeguati.
- NL** **Opgelet:** een vakkundige persoon dient het meubelstuk aan de muur te bevestigen; voor de montage aan de muur zijn immers aangepaste pluggen vereist.
- PL** **Uwaga:** Mocowanie mebla do ściany mogą przeprowadzić wyłącznie wykwalifikowane osoby, z uwagi na zastosowanie odpowiednio dopasowanych kołków do rodzaju ściany.
- CZ** **Pozor:** Montáž nábytku na stěnu musí provést odborník, protože k montáži na stěnu jsou zapotřebí upravené hmoždinky.
- SK** **Pozor:** Upevnenie nábytku na stenu musí vykonať odborník, nakoľko sú pre montáž na stenu potrebné vhodné hmoždinky.
- HU** **Figyelem:** A bútorelemek falra rögzítését szakembernek kell végeznie, mert a rögzítéshez megfelelő tiplit kell használni.
- RO** **Atenție:** Fixarea la perete a piesei de mobilier se realizează numai de către personal competent, deoarece montajul de perete necesită dibluri adecvate.
- TR** **Dikkat:** Mobilya parçasının duvara sabitlenmesi, duvar montajı için özel uyarlanmış dübeller gerektirdiğinden bu iş sadece bu konuda uzman bir kişi tarafından gerçekleştirilmelidir.
- RU** **Внимание:** Поскольку для монтажа на стене необходимо использовать специальные дюбели, мебель должна быть закреплена на стене квалифицированным персоналом.
- LV** **Uzmanību:** Mēbeles montāžai pie sienas paredzēts izmantot speciālus dībeļus. Ietecams šo darbu veikt kvalificētam darbiniekam.



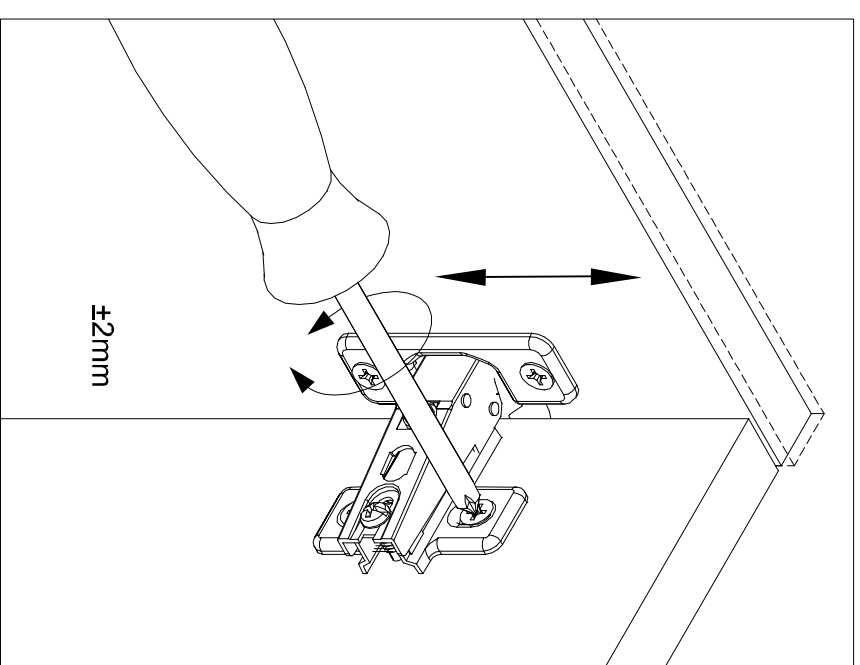
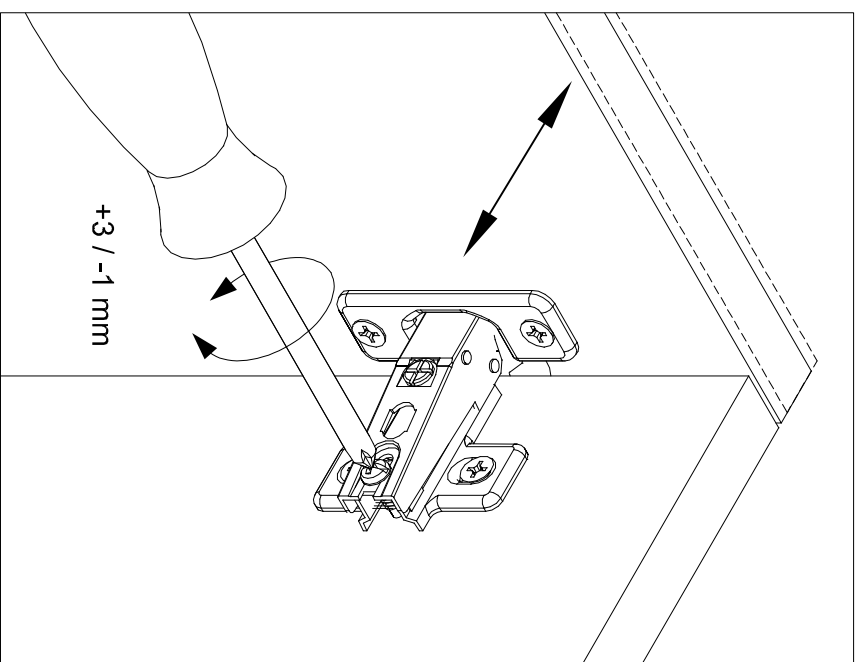
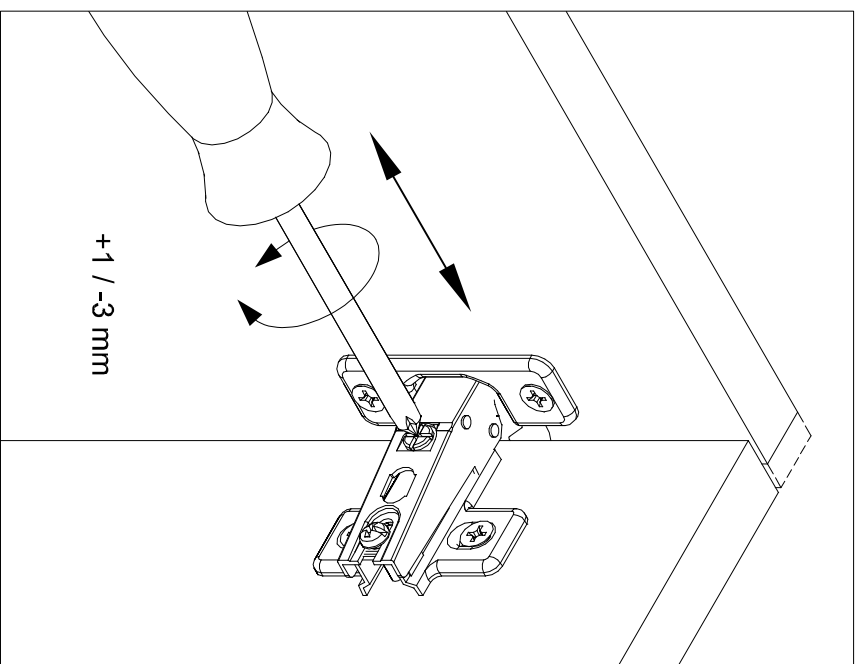

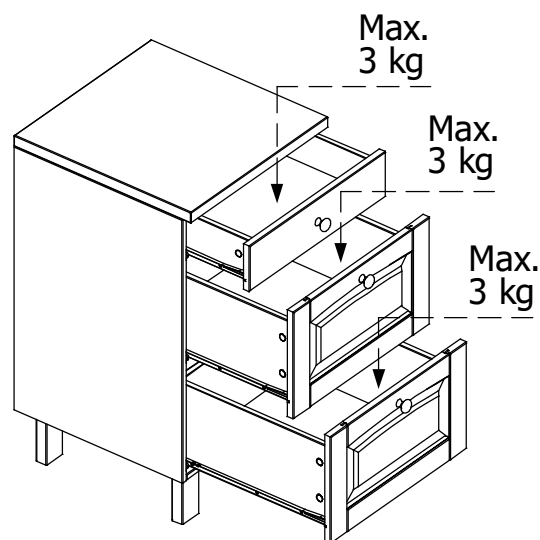
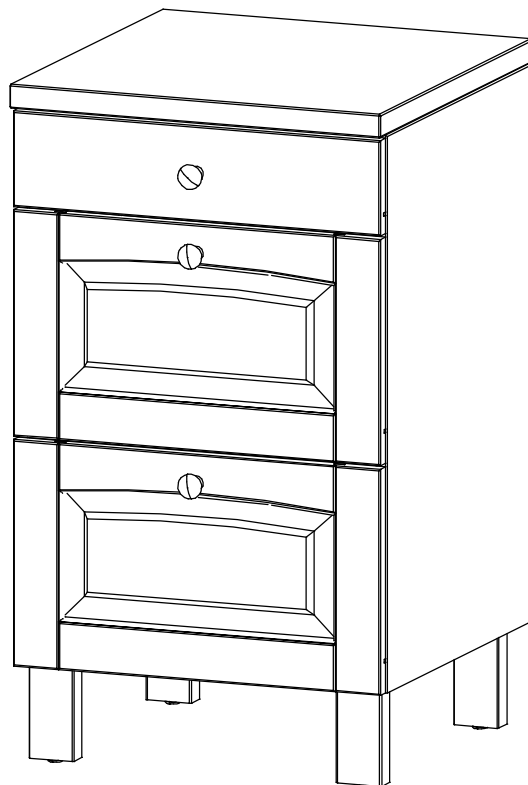
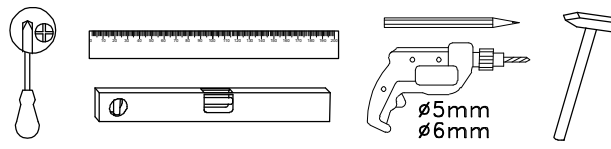
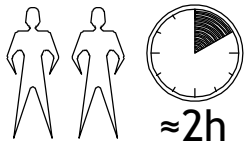



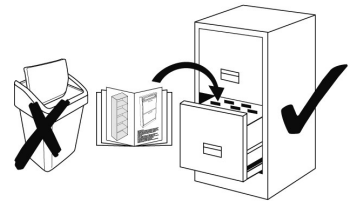
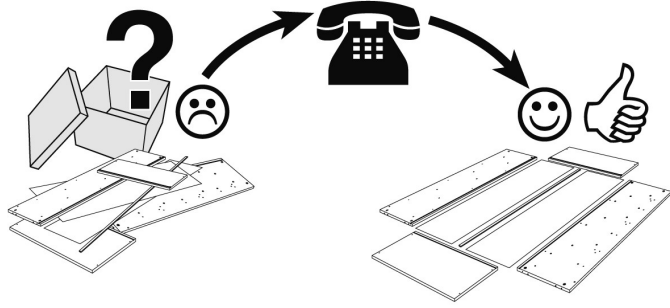







- ⒸZ) Úprava dverí
- Ⓓ) Das Richten einer Türe
- Ⓕ) Réglage d'une porte.
- ⒽU) Beállítás egy ajtó
- Ⓘ) Regolare una porta
- ⒻV) Durvju regulēšana
- ⒼNL) Instellen van een deur
- ⒼPL) Regulacja drzwi
- ⒼRO) Reglarea o ușă
- ⒼRU) Регулировка Дверей
- ⒼSK) Úprava dverí
- ⒼTR) Bir kapı ayarlama
- ⒼUK) Adjusting a door
- ⒼFIN) Oven säätö

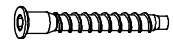



idp68242-1 idp68242-2

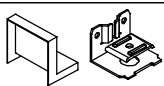

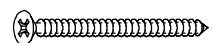

Service • Assistenza • Dienstverlening • Serwis Servis • Szerviz • Сервисная служба	
Name • Nom • Nome • Naam Nazwa • Jméno • Název • Név Denumire • Isim • Название	
Nr • No • N • Номер • Č • Sz	
Тур • Туре • Тір • Тірус • Тіро Тип	
	
	

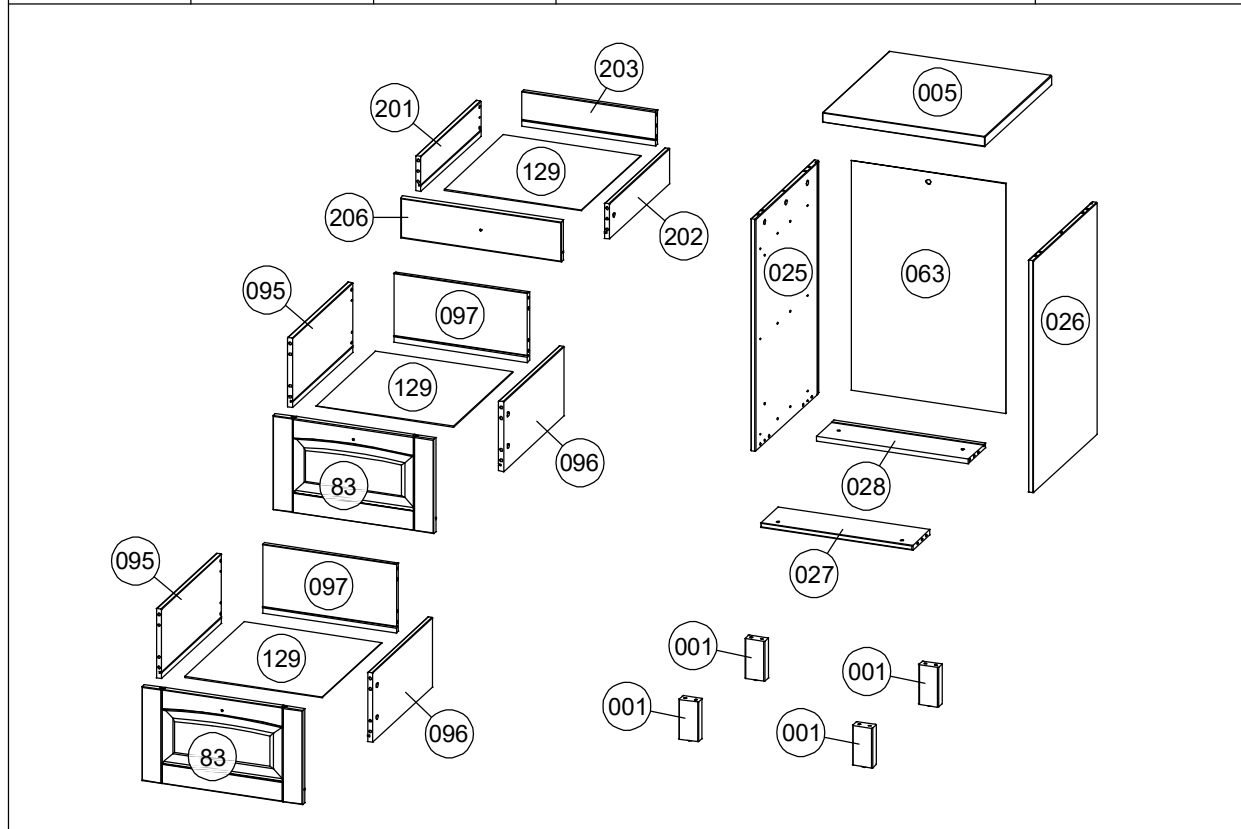
					D2		x30 ø 5/11x34	
D5		x30 ø 15x12,5	H1		x40 ø 8x30	A121		x36 ø 3x15
D4		x16 ø 17	E159		x3 450mm	A15		x24 ø 5,8x11
D24		x4 ø 13	A5		x1 SW4	A27		x4 ø 7x50
B122		x3	A278		x2 M4x15	A16		x5 M4x25
N3		x6 ø 7x1,5	D36		x8 15x15x10	A10		x2 ø 4x16
D31		x1	H8		x1 ø 6x35	A69		x1 ø 4x60

Teil Nr. Pièces Nr. Pieces Nr. Часть Ном. Kawalek Nr. Parça No Kusù Nr. Kusov Nr. Pezzi Nr. Nr piese. Darab száma. Stukken Nr. Kārtas Nr.	Anzahl Quantité Quantity Количество Ilość Miktar Množství Množstvo Quantità Cantitatea Mennyiség Hoeveelheid Skaitis	Kasten Nr. Colli Nr. Colli Nr. Коробка Ном. Polu Nr. Kutusu Nr. Kolonka Č. Počet balení Colli Nr. Nu pachete Colli száma. Colli Nr. Kastes Nr.	Maß, mm Dimensions, mm Dimensions, mm Размеры, mm Wymiary, mm Boyutlar, mm Rozměry, mm Rozmery, mm Dimensioni, mm Dimensiuni, mm Méterek, mm Afmetingen, mm Izmēri, mm	✓
001	4	1 / 1	120 x 60 x 30	
005	1	1 / 1	491 x 500 x 30	
025	1	1 / 1	700 x 476 x 15	
026	1	1 / 1	700 x 476 x 15	
027	1	1 / 1	459 x 130 x 15	
028	1	1 / 1	459 x 130 x 15	
063	1	1 / 1	693 x 468 x 3	
095	2	1 / 1	450 x 210 x 15	
096	2	1 / 1	450 x 210 x 15	
097	2	1 / 1	404 x 208 x 15	
129	3	1 / 1	415 x 444 x 3	
201	1	1 / 1	450 x 106 x 15	
202	1	1 / 1	450 x 106 x 15	
203	1	1 / 1	404 x 104 x 15	
206	1	1 / 1	486 x 120 x 18	
83	2	1 / 1	486 x 284 x 18	



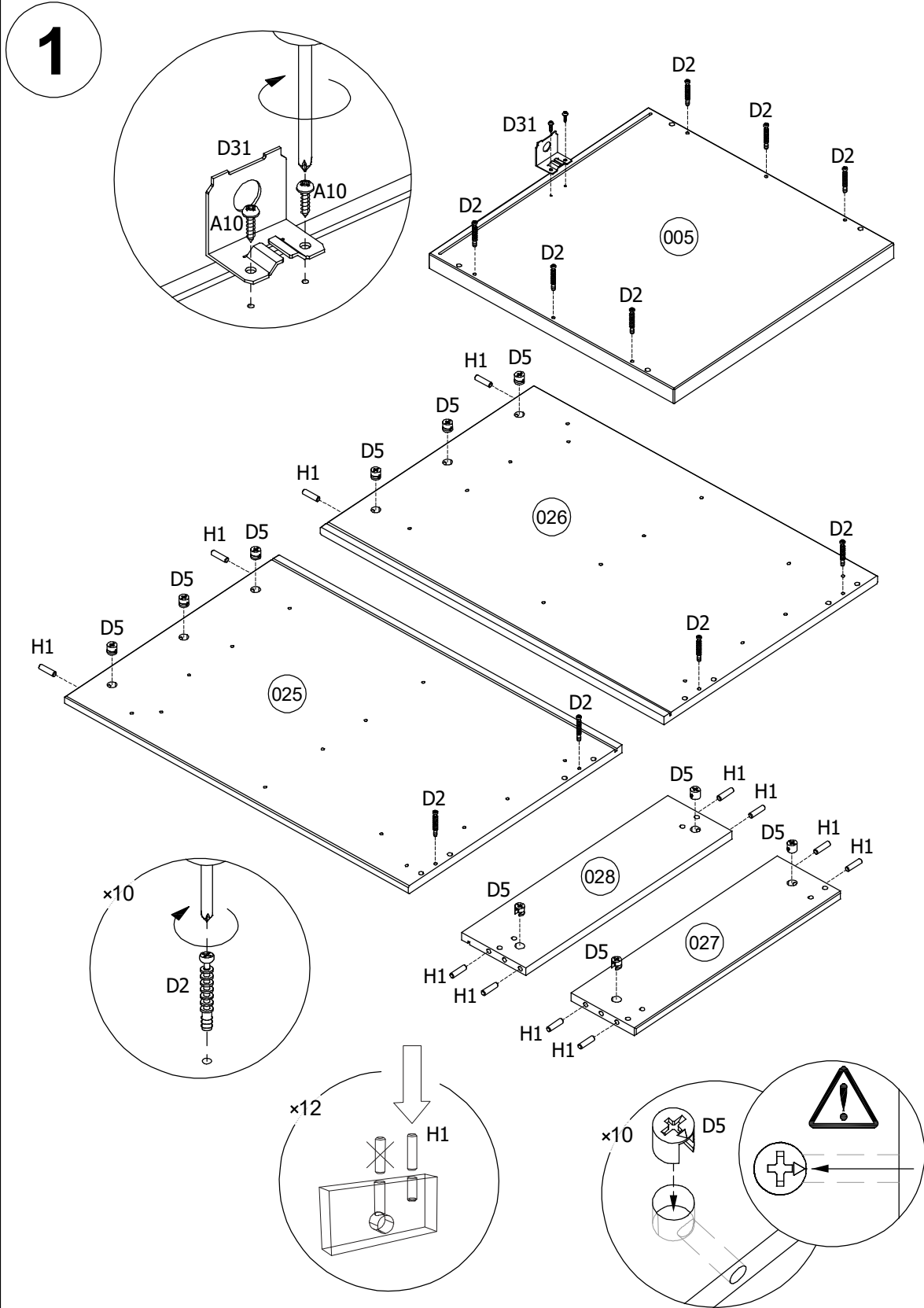

idp68242-1 idp68242-2

H1		x12 ø 8x30	D2		x10 ø 5/11x34	D5		x10 ø 15x12,5
D31		x1	A10		x2 ø 4x16			



idp68242-1 idp68242-2

E159	 x3 450mm	A15	 x24 ø 5,8x11
------	---	-----	---

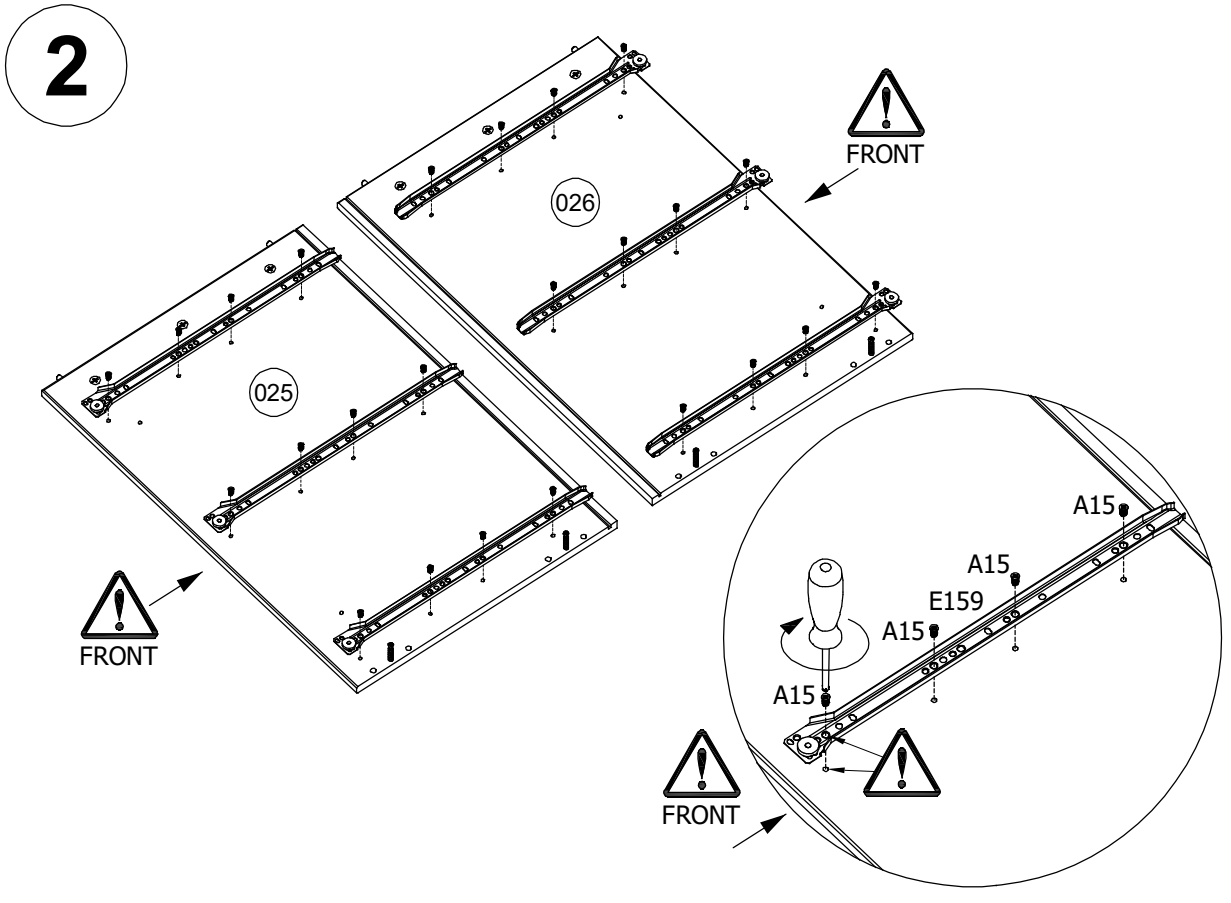

A121	 x18 ø 3x15
------	---

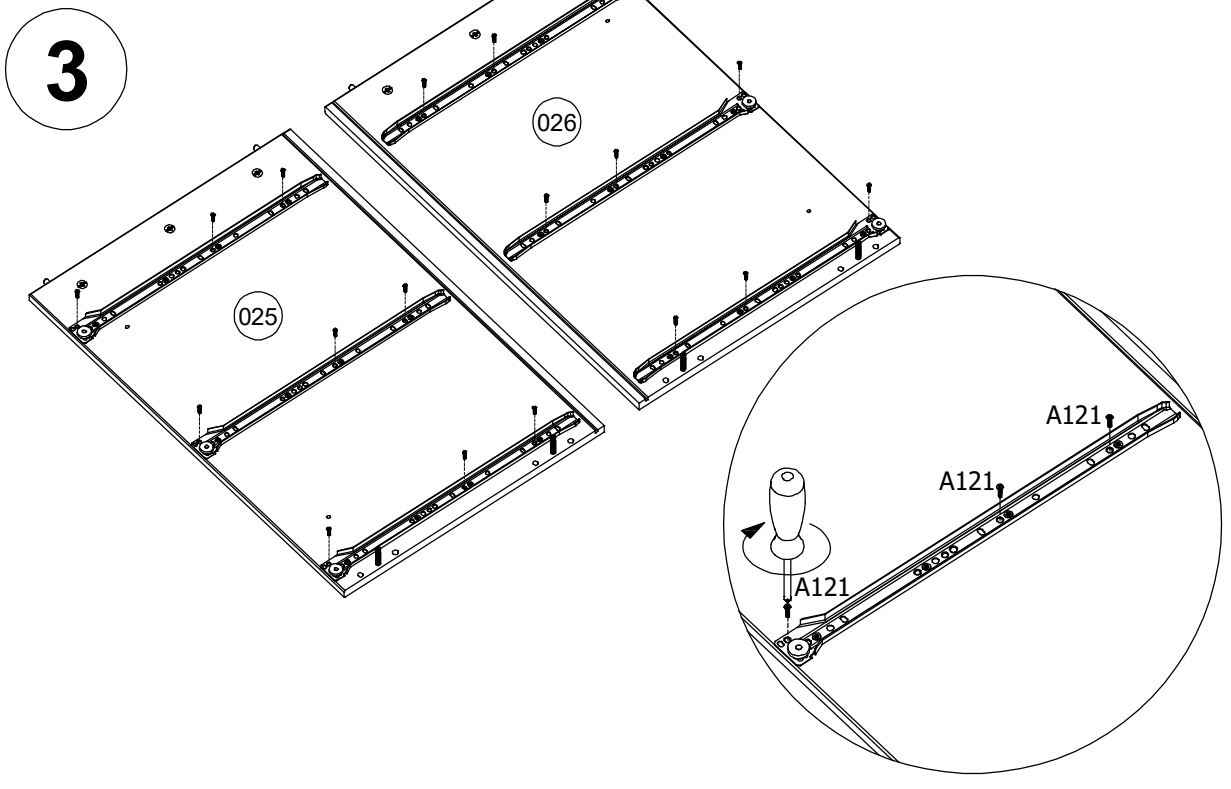

idp68242-1 idp68242-2

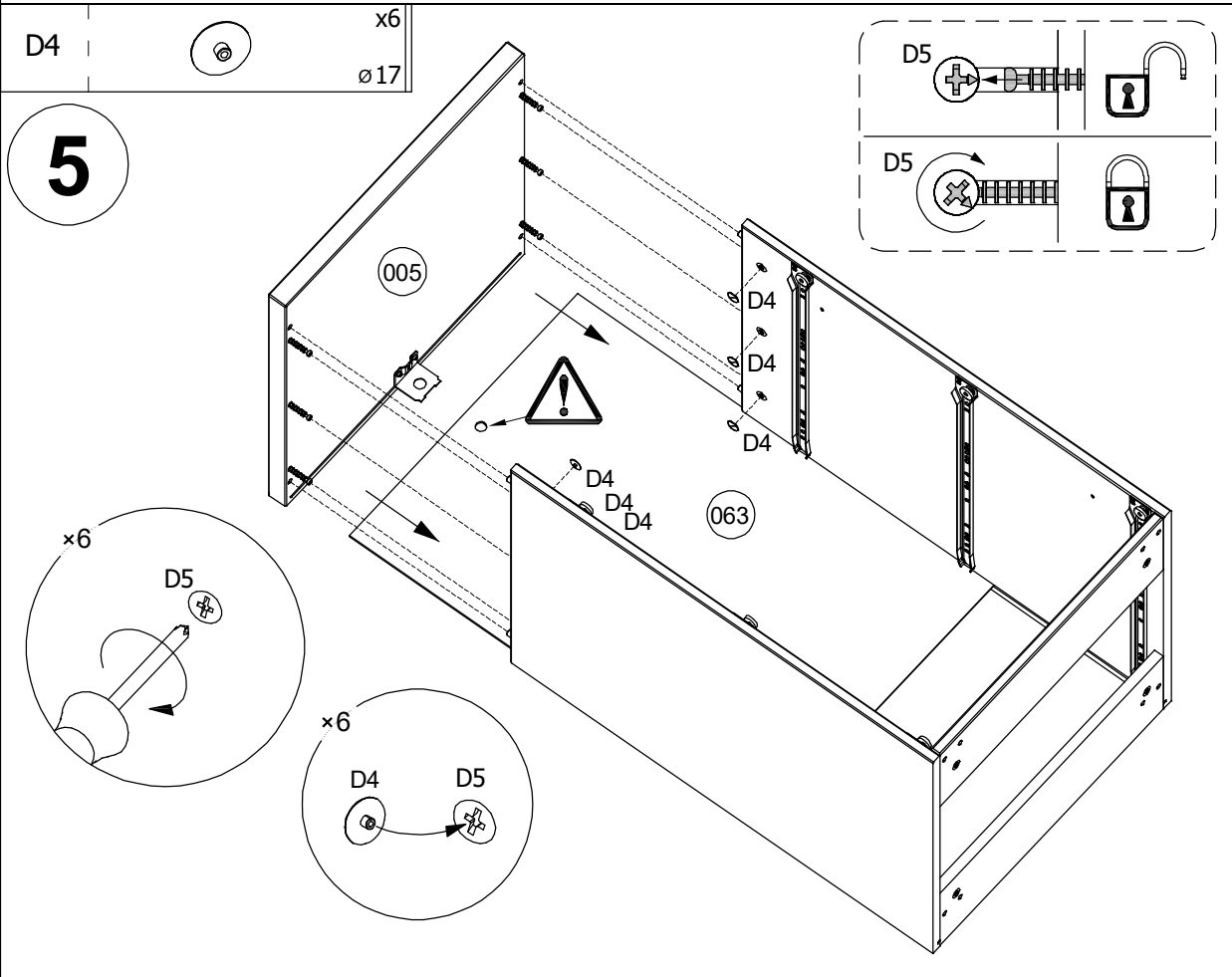
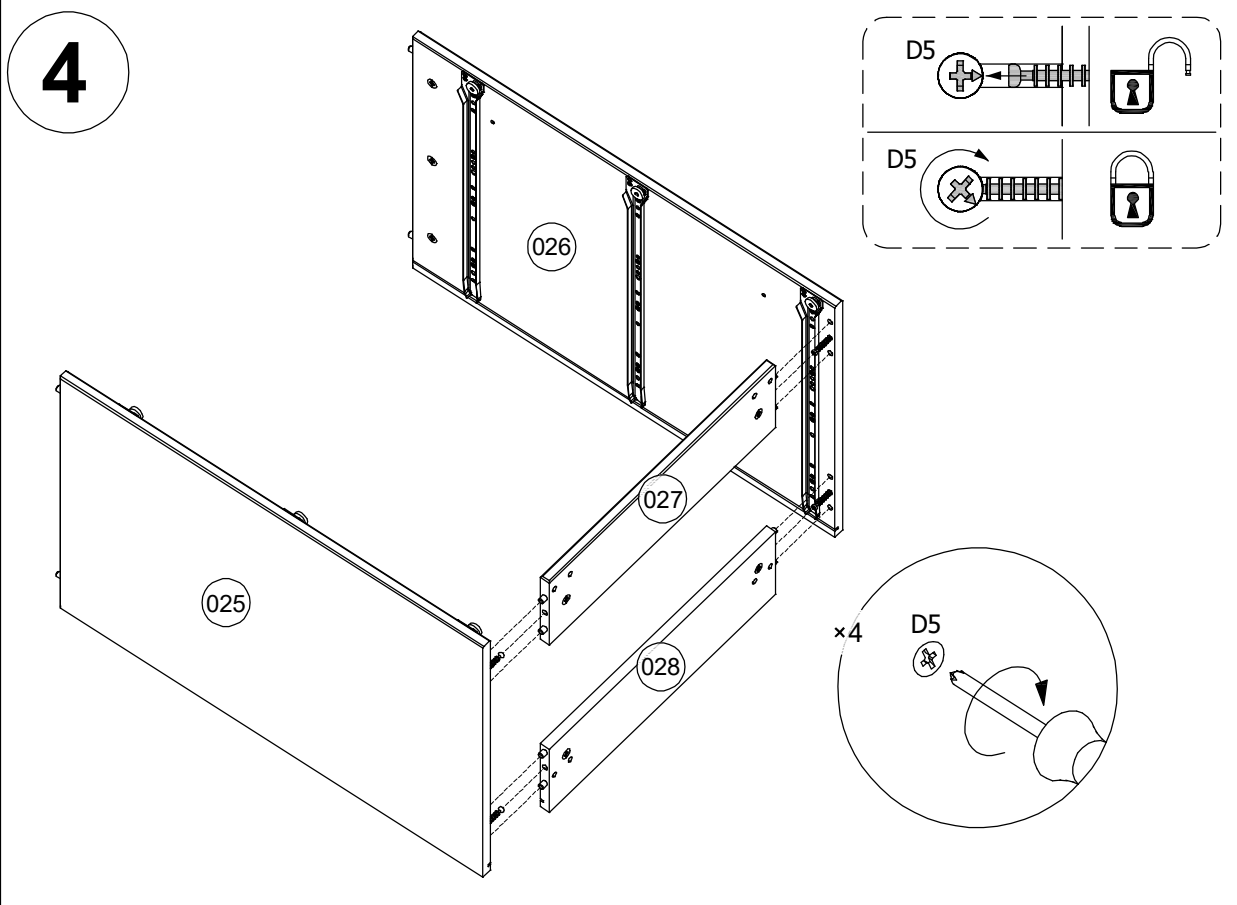

idp68242-1 idp68242-2

H1



x4

∅ 8x30

6

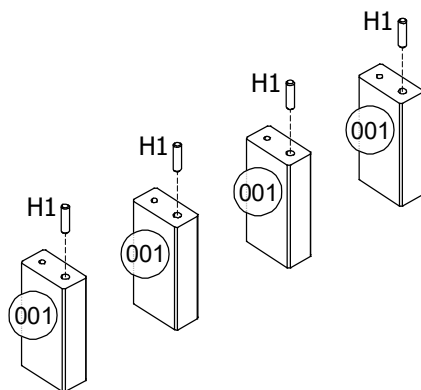

A27



x4

∅ 7x50

A5



x1

SW4

D24



x4

∅ 13

7

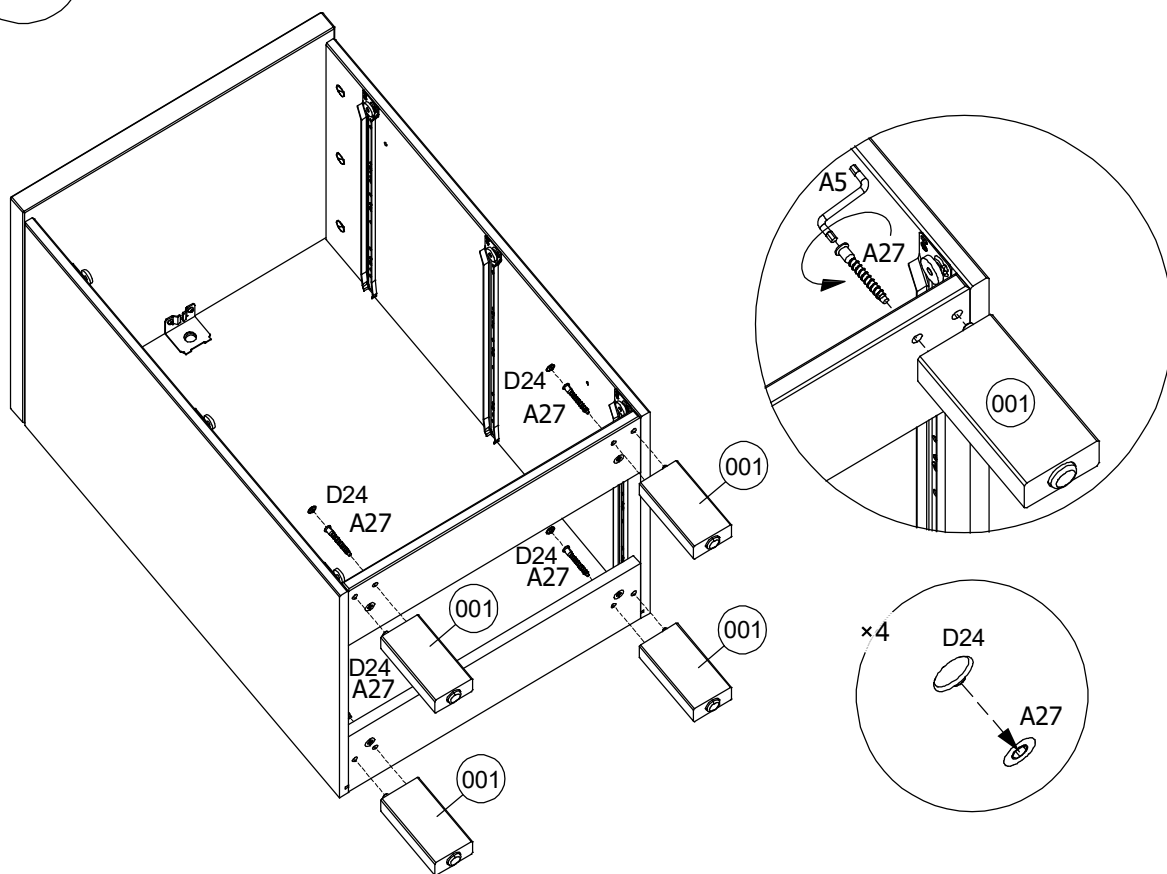

idp68242-1 idp68242-2

8

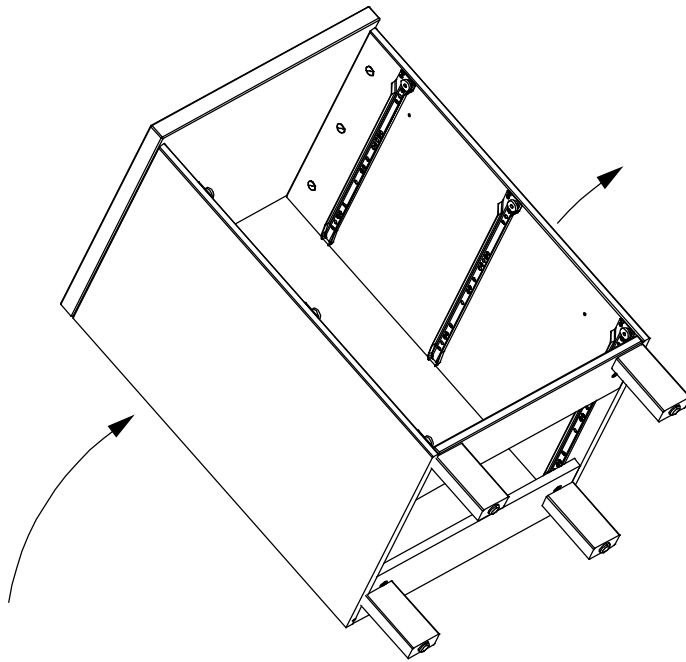
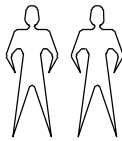

D36



x8

15x15x10

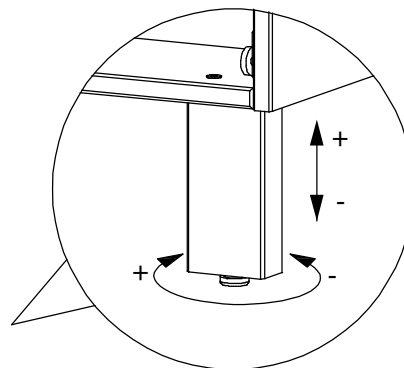
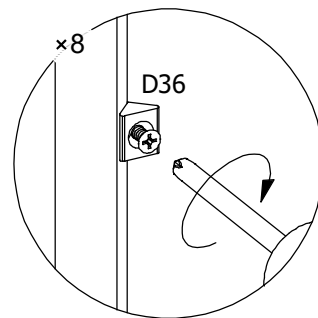
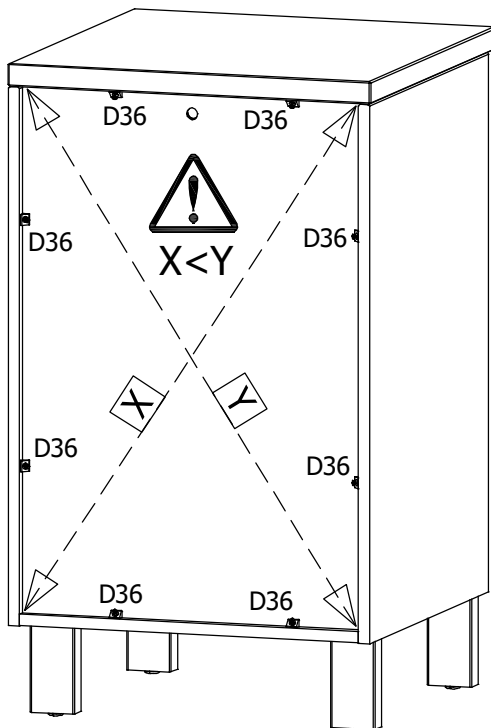
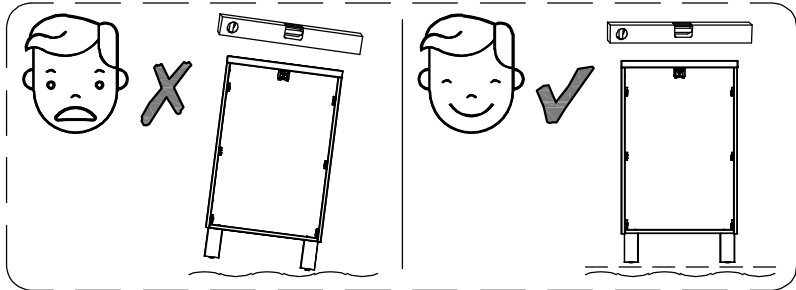

9

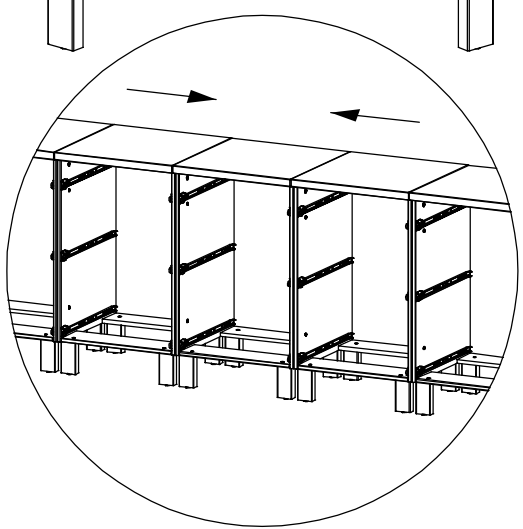
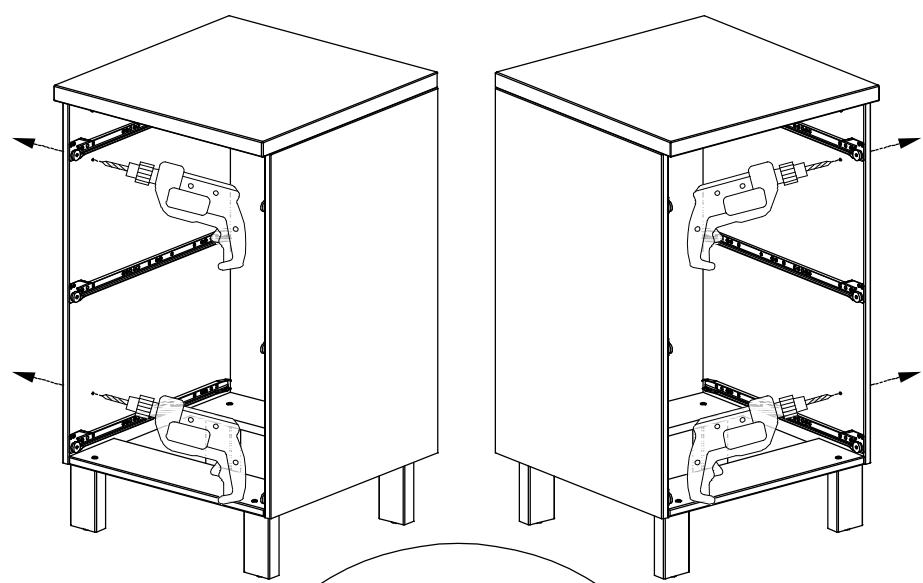
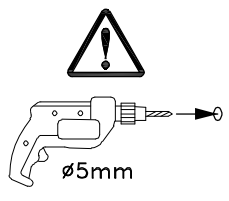

idp68242-1 idp68242-2

10



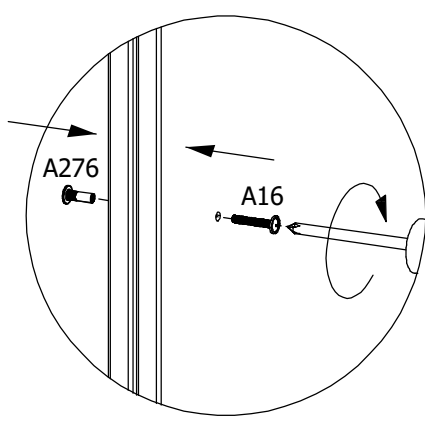
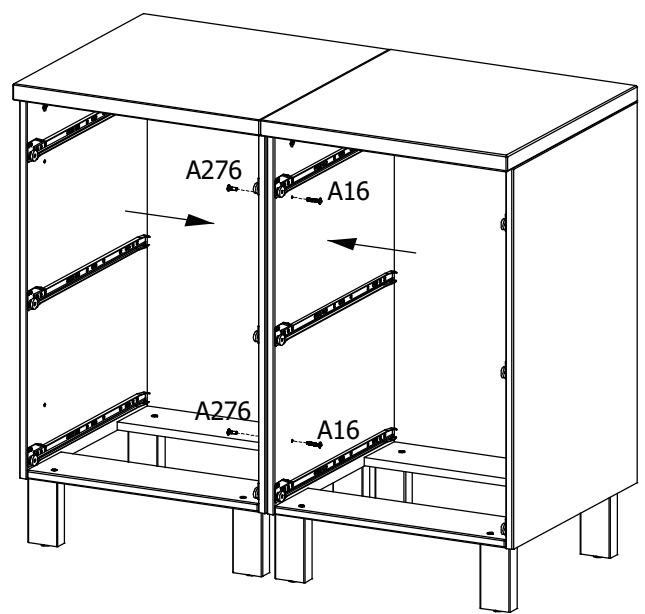

A278		x2	A16		x2
		M4x15			M4x25

11

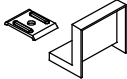

idp68242-1 idp68242-2

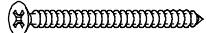
D31	 x1	H8	 x1	A69	 x1
			∅ 6x35		∅ 4x60

12

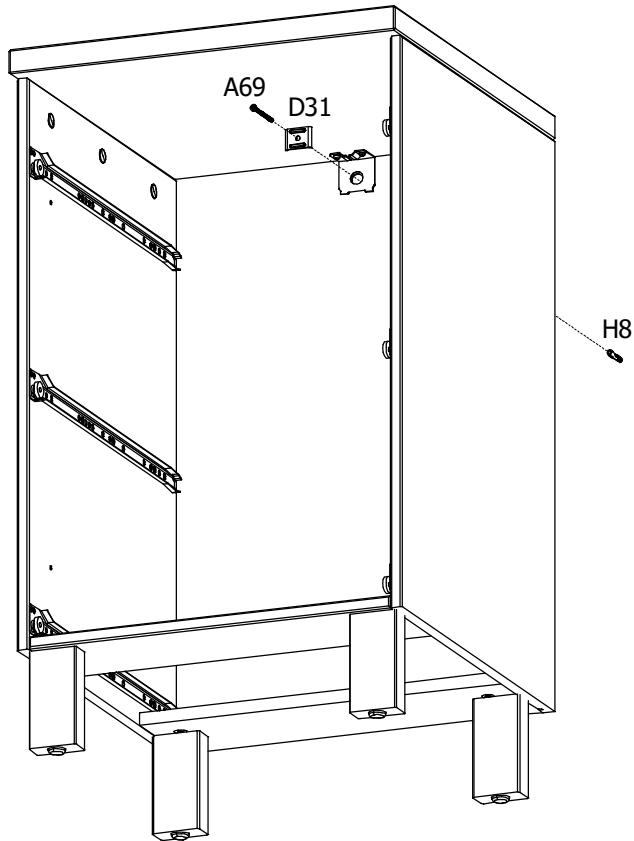
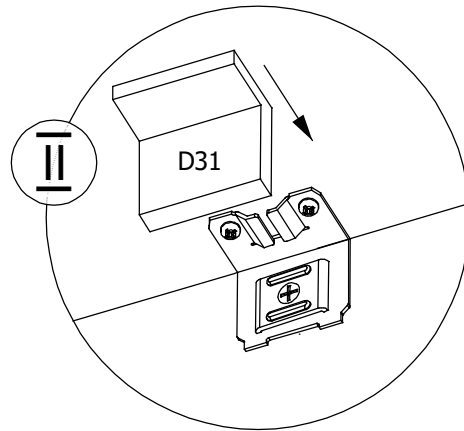
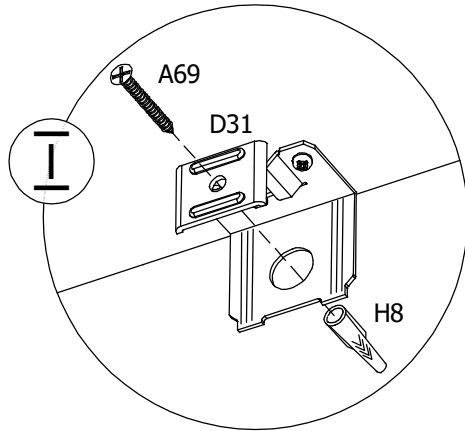
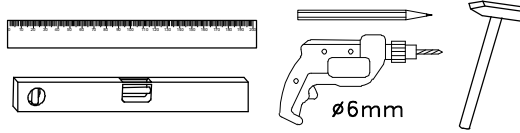

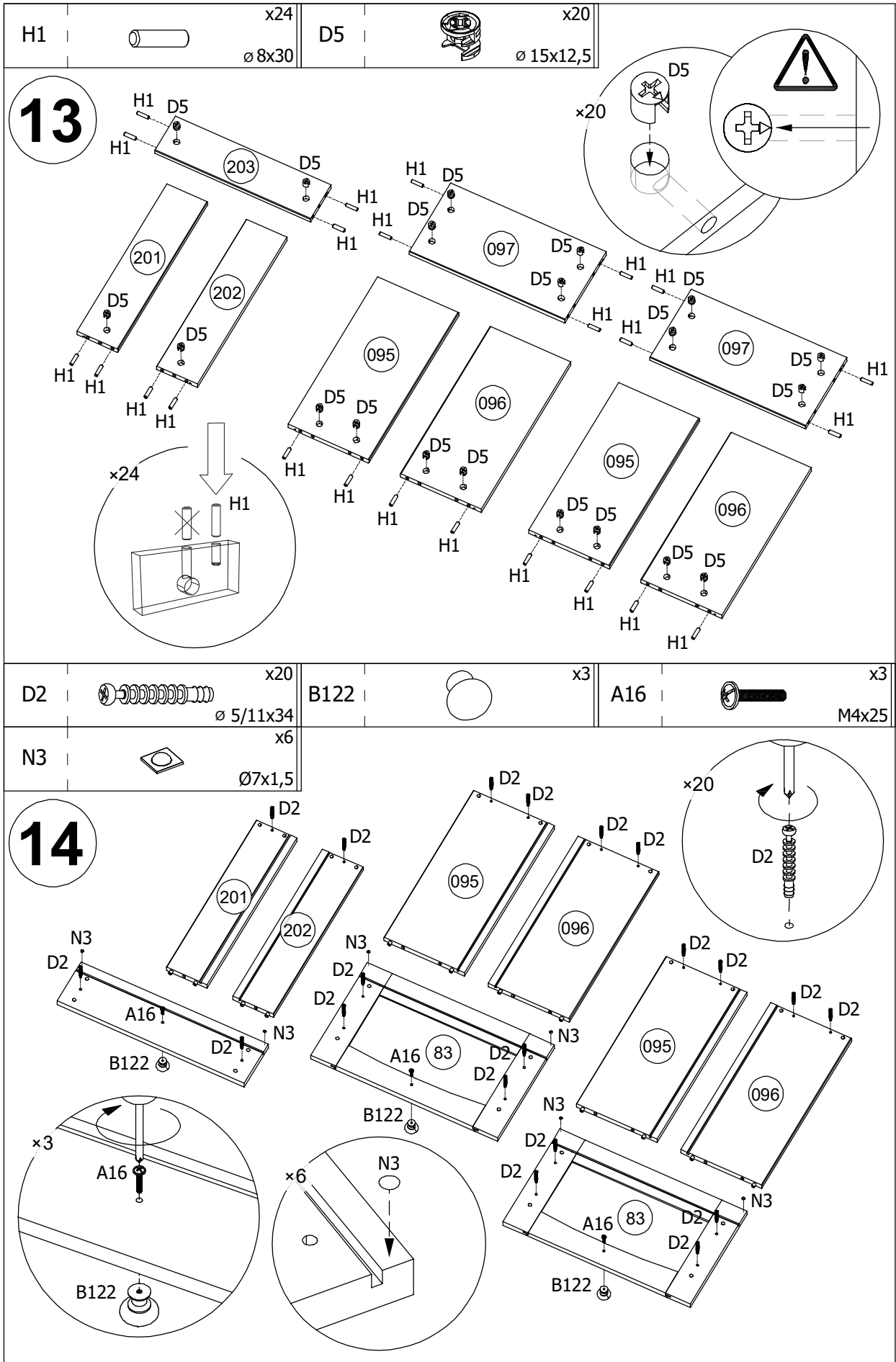

idp68242-1 idp68242-2

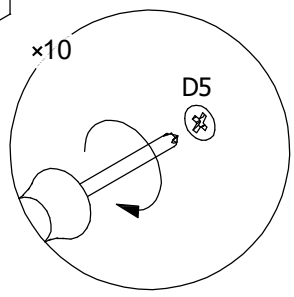
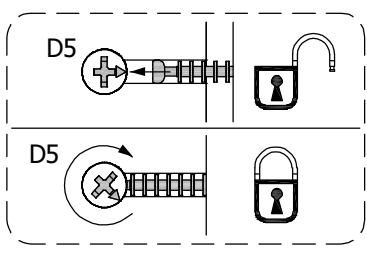
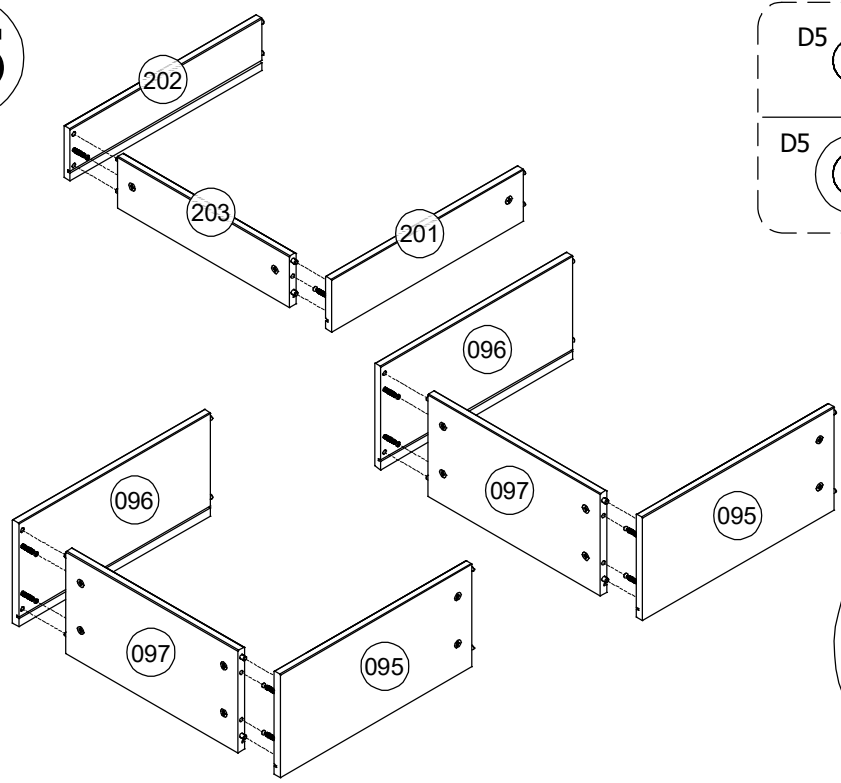

idp68242-1 idp68242-2

15



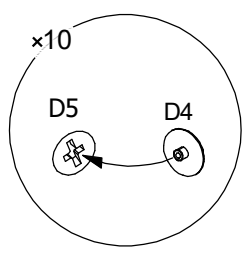
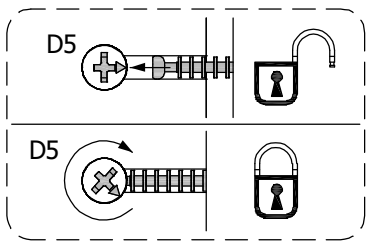
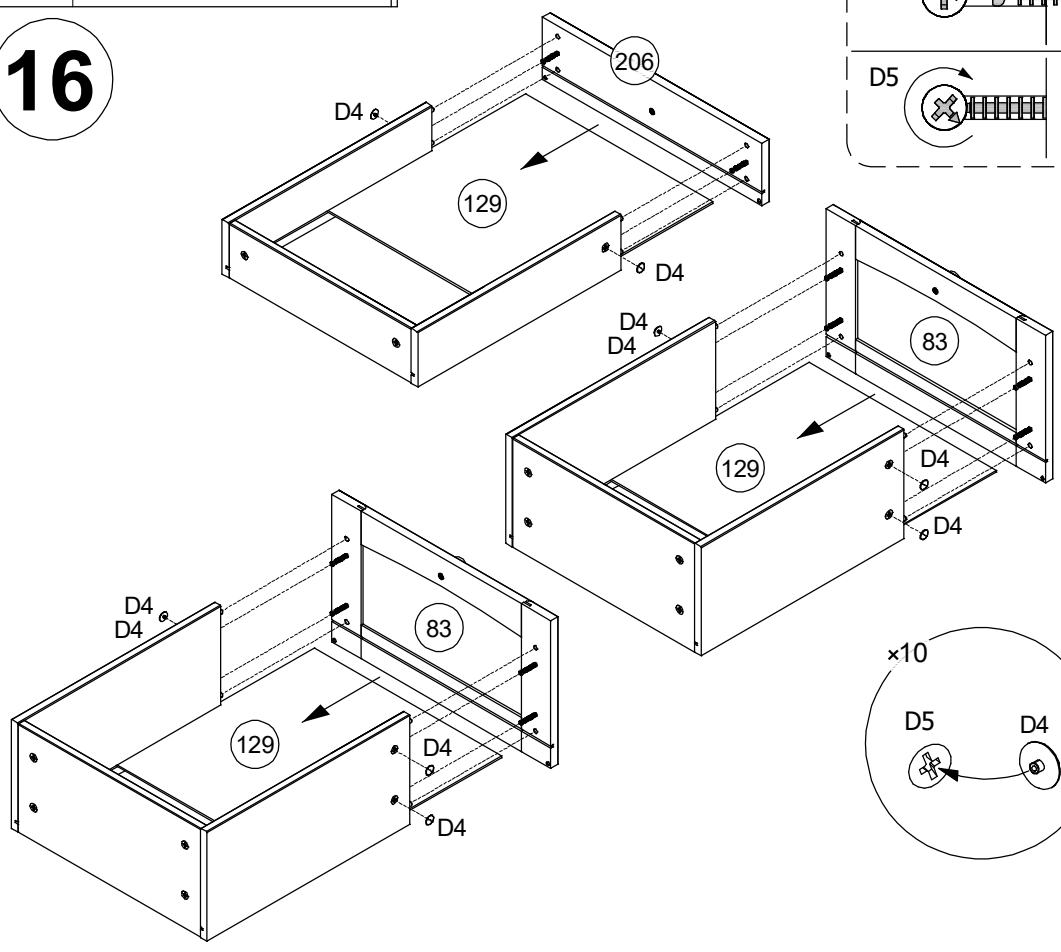

D4  x10
ø17

16



idp68242-1 idp68242-2

E159	 x3 450mm	A121	 x18 ø 3x15
------	---	------	---

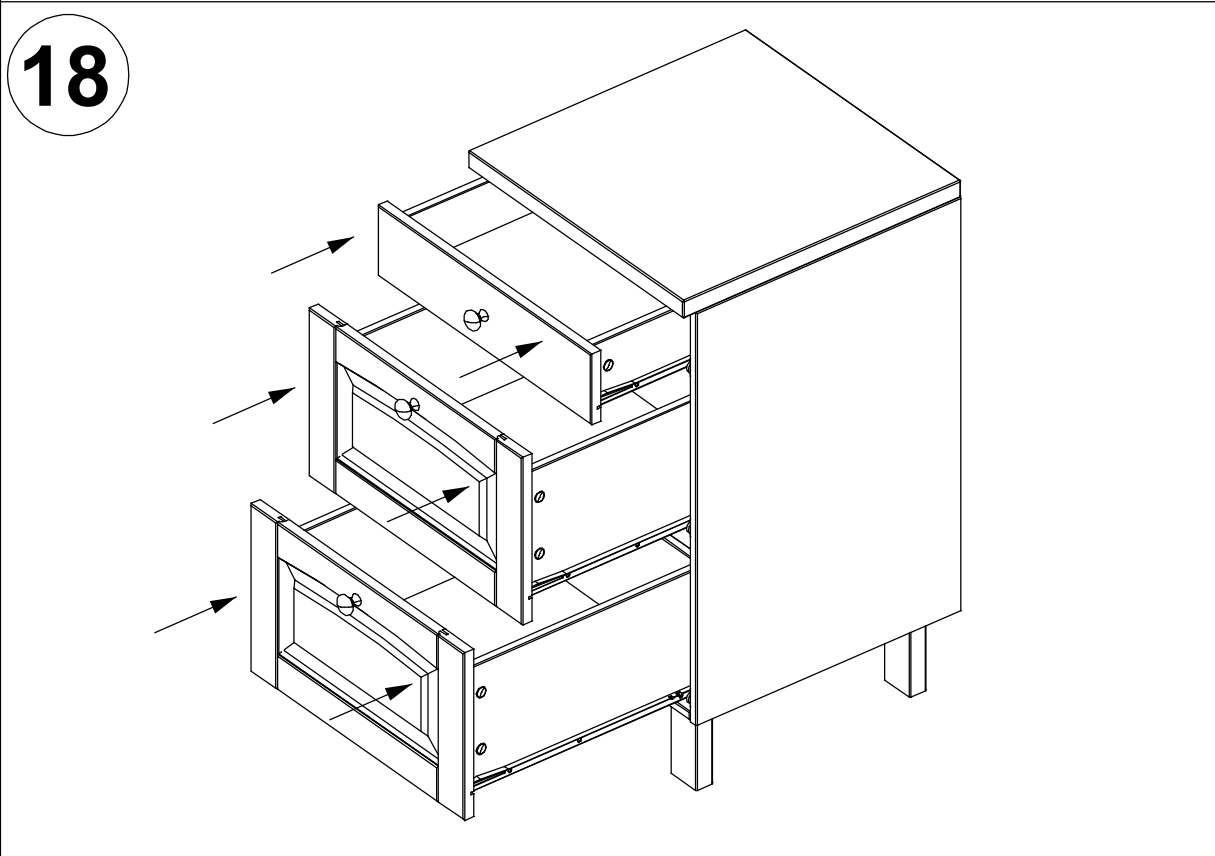
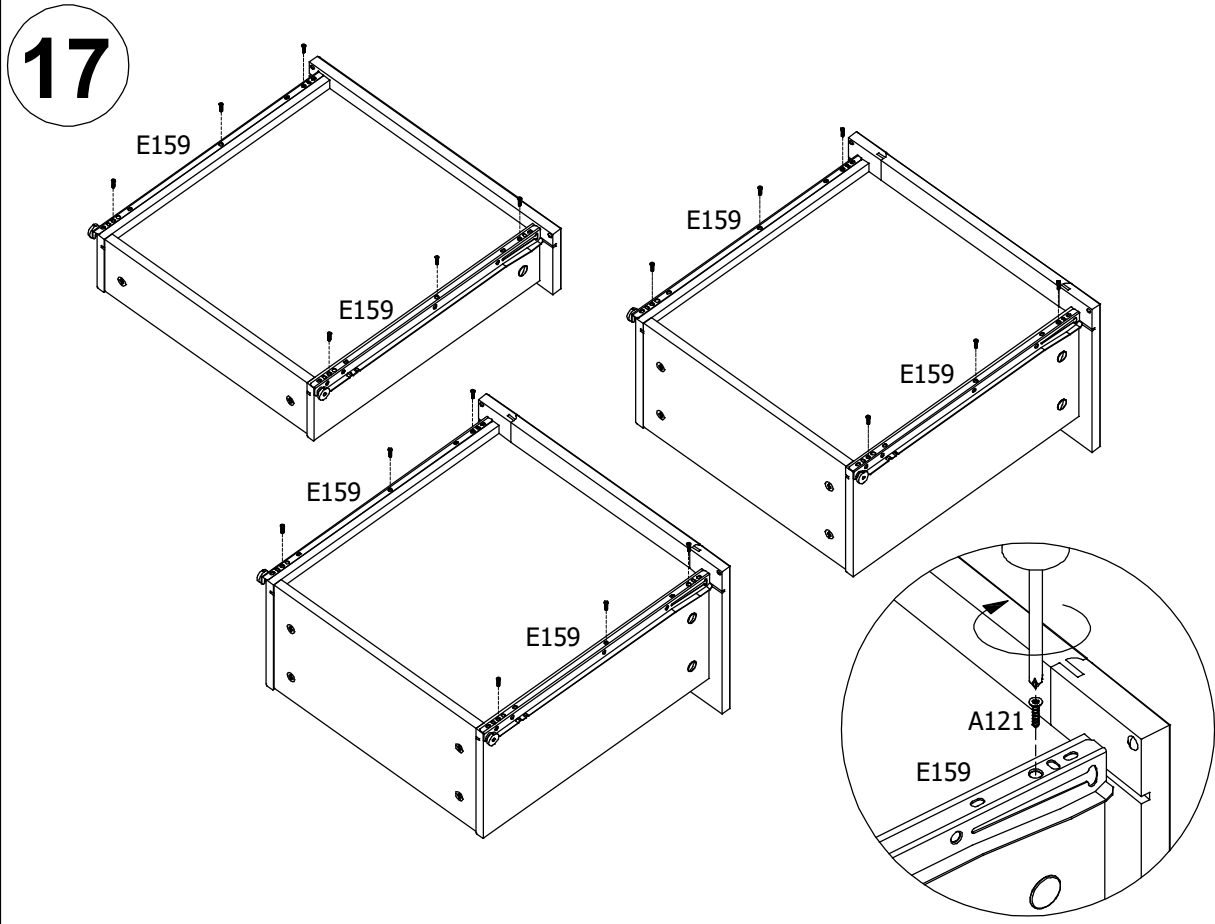

idp68242-1 idp68242-2

H8 

A69 
 ø4x60

 ø6mm

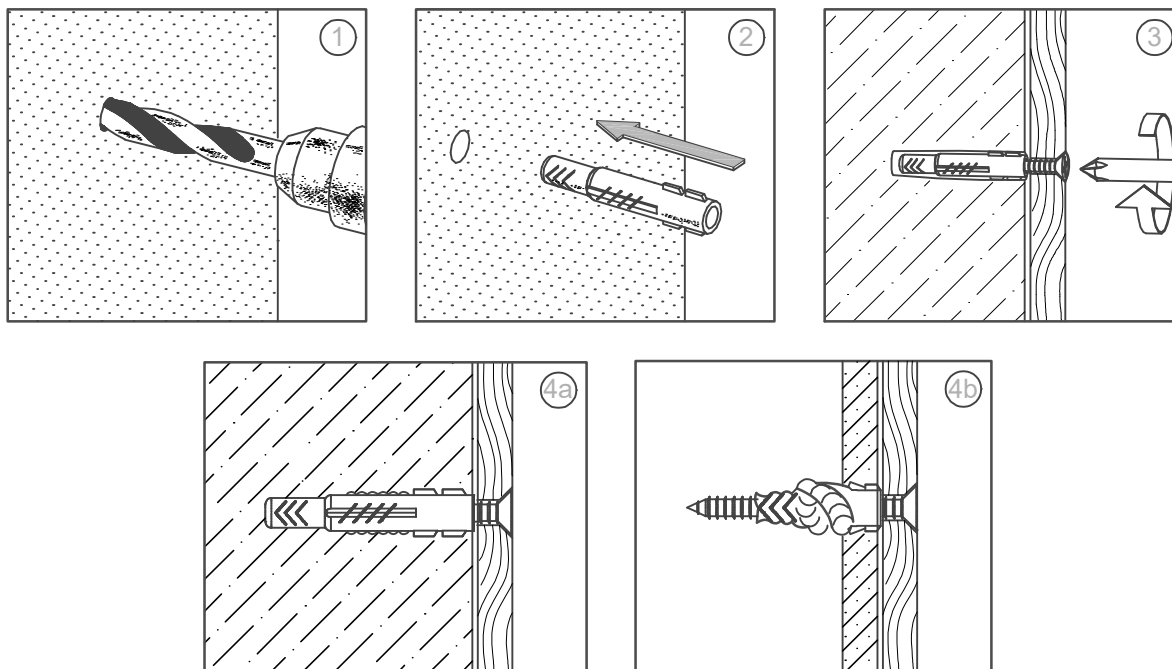

- D** **Achtung:** Die Befestigung des Möbelstückes an der Wand muss von einer fachkundigen Person vorgenommen werden, da für die Montage an die Wand angepasste Dübel erforderlich sind.
- GB** **Attention:** A qualified professional is required when mounting furniture to the wall since dowels corresponding to the wall are required for this.
- FR** **Attention :** La fixation du meuble contre le mur doit être effectuée par une personne compétente car, pour le montage mural, il faut utiliser des chevilles adaptées.
- IT** **Attenzione:** Il fissaggio del mobile alla parete deve essere eseguito da persone esperte, dato che occorrono tasselli adeguati.
- NL** **Opgelet:** een vakkundige persoon dient het meubelstuk aan de muur te bevestigen; voor de montage aan de muur zijn immers aangepaste pluggen vereist.
- PL** **Uwaga:** Mocowanie mebla do ściany mogą przeprowadzić wyłącznie wykwalifikowane osoby, z uwagi na zastosowanie odpowiednio dopasowanych kołków do rodzaju ściany.
- CZ** **Pozor:** Montáž nábytku na stěnu musí provést odborník, protože k montáži na stěnu jsou zapotřebí upravené hmoždinky.
- SK** **Pozor:** Upevnenie nábytku na stenu musí vykonať odborník, nakoľko sú pre montáž na stenu potrebné vhodné hmoždinky.
- HU** **Figyelem:** A bútorelemek falra rögzítését szakembernek kell végeznie, mert a rögzítéshez megfelelő tiplit kell használni.
- RO** **Atenție:** Fixarea la perete a piesei de mobilier se realizează numai de către personal competent, deoarece montajul de perete necesită dibluri adecvate.
- TR** **Dikkat:** Mobilya parçasının duvara sabitlenmesi, duvar montajı için özel uyarlanmış dübeller gerektirdiğinden bu iş sadece bu konuda uzman bir kişi tarafından gerçekleştirilmelidir.
- RU** **Внимание:** Поскольку для монтажа на стене необходимо использовать специальные дюбели, мебель должна быть закреплена на стене квалифицированным персоналом.
- LV** **Uzmanību:** Mēbeles montāžai pie sienas paredzēts izmantot speciālus dībeļus. Ietecams šo darbu veikt kvalificētam darbiniekam.