



# ARTISAN 7x7



USER MANUAL | MODE D'EMPLOI | MANUAL DEL USUARIO | GEBRAUCHSANLEITUNG |  
 GEBRUIKSHANDLEIDING | MANUALE PER L'UTENTE | MANUAL DO UTILIZADOR

## IMPORTANT | IMPORTANT | IMPORTANTE

RETAIN FOR FUTURE REFERENCE: READ CAREFULLY

CONSERVER POUR RÉFÉRENCE FUTURE ET LIRE ATTENTIVEMENT

CONSERVE PARA REFERENCIA FUTURA. LEA CUIDADOSAMENTE ANTES

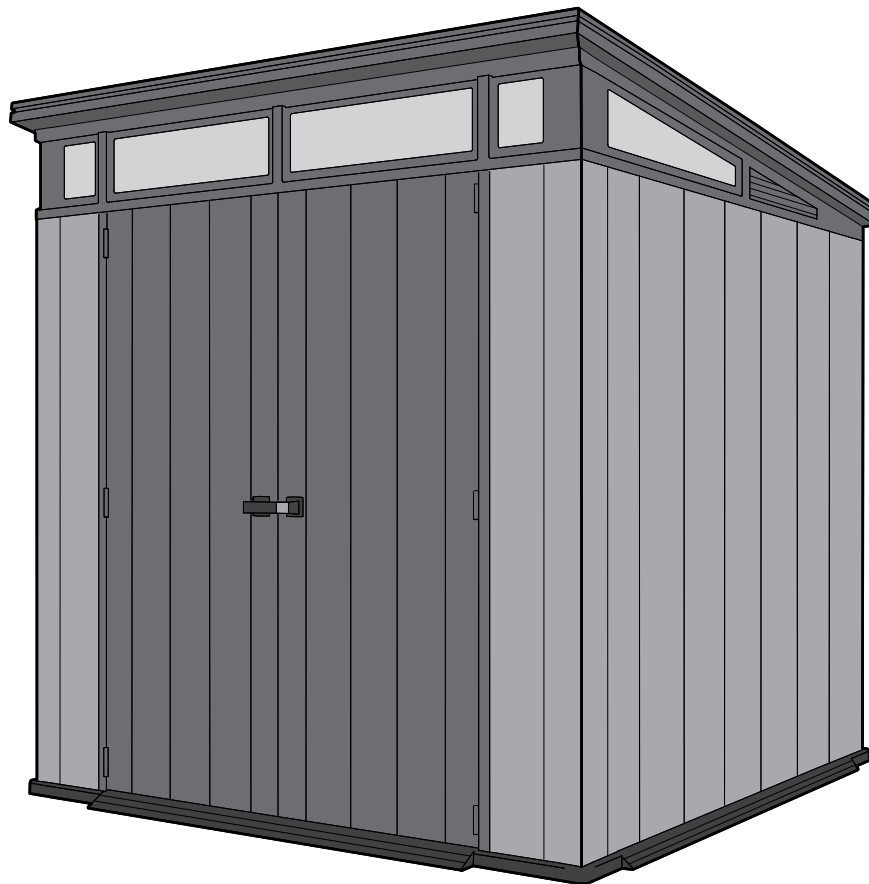

A-1424-6 388130

SKU: 17203426

	<p><b>US, Canada:</b>                  Tel: +1-877-638-7056                  Fax: +1-704-263-9271</p> <p><b>UK:</b> Tel: +44-121-506-0008                  Fax: 44-121-422-0808</p> <p><b>Spain:</b> Tlf: 34-976-460-006                  Fax: 34-976-460-281</p> <p><b>Other European Countries:</b>                  Tel: +31-8847-22277, Fax: +31-1612-27002</p>		<p><b>WARRANTY ACTIVATION</b></p>
--	-----------------------------------------------------------------------------------------------------------------------------------------------------------------------------------------------------------------------------------------------------------------------------------------------------------------------------------------------------------------------------------------	--	-----------------------------------

**WARRANTY ACTIVATION** Thank you for your purchase of the Keter shed. In order to activate your warranty, please log onto our website and fill in the form under warranty activation.  
[il.keter.com/en/warrant-activation](http://il.keter.com/en/warrant-activation)

SITE PREPARATION | PRÉPARATION DU SITE | PREPARACIÓN DEL LUGAR | VORBEREITUNG DES AUFSTELLUNGSORTES  
| VOORBEREIDING VAN HET TERREIN | PREPARAZIONE DEL LUOGO DI MONTAGGIO | PREPARAÇÃO DO LOCAL

Level the ground surface | Égalisez la surface du sol | Nivela la superficie del suelo | Ebenen Sie die Bodenoberfläche |  
Maak de bodem vlak | Livella la superficie del terreno | Nivela a superfície do solo

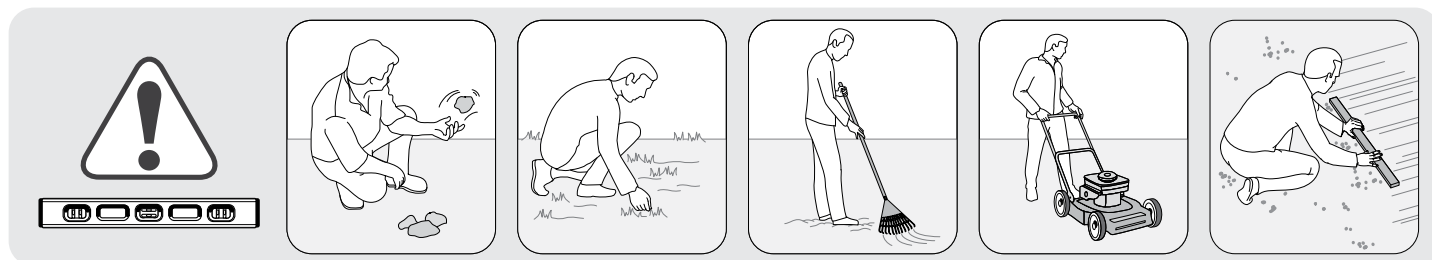

Recommendation: Construct a wooden or concrete base as a foundation | Recommandation: fabriquez une base en bois ou en béton en guise de fondation | Recomendación: construya una base de madera o de cemento a modo de cimiento | Empfehlung: Bauen Sie als Fundament eine Grundfläche aus Holz oder Beton | Aanbeveling: maak een houten of betonnen ondergrond als fundering | Raccomandazione: costruisci una base di legno o di cemento come fondamenta | Recomendação: Construa uma base de madeira ou de cimento como fundação

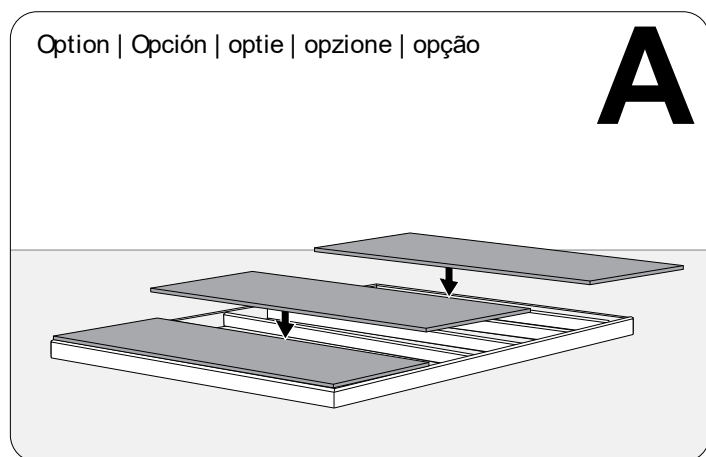

For external access during assembly, make sure to leave enough room around the outside of the shed assembly site.

Pour un accès externe au cours du montage, veillez à laisser suffisamment de place autour du site de montage.

Para tener un acceso exterior durante el montaje, asegúrese de dejar suficiente espacio alrededor del lugar de montaje del cobertizo.

Lassen Sie am Aufstellungsort außerhalb des Schuppens ausreichend Platz, so dass Sie während des Aufbaus von außen Zugang zum Schuppen haben.

Om tijdens de montage aan de buitenkant van het schuurtje te kunnen werken, moet u ervoor zorgen dat u genoeg ruimte laat aan de buitenkant van de montageplaats.

Per l'accesso esterno durante il montaggio, assicurati di lasciare abbastanza spazio intorno alla parte esterna del luogo di montaggio del deposito attrezzi.

Para ter acesso externo durante a montagem certifique-se de que deixa espaço suficiente em redor do exterior do local de montagem do abrigo.

External floor measurements are: | Les mesures externes de la étage sont: | Las medidas del suelo externo son: | Die Außen-Bodenmaße betragen: | De afmetingen van de externe vloer zijn: | Le misure del pavimento esterno sono: | As medidas externas do chão são:

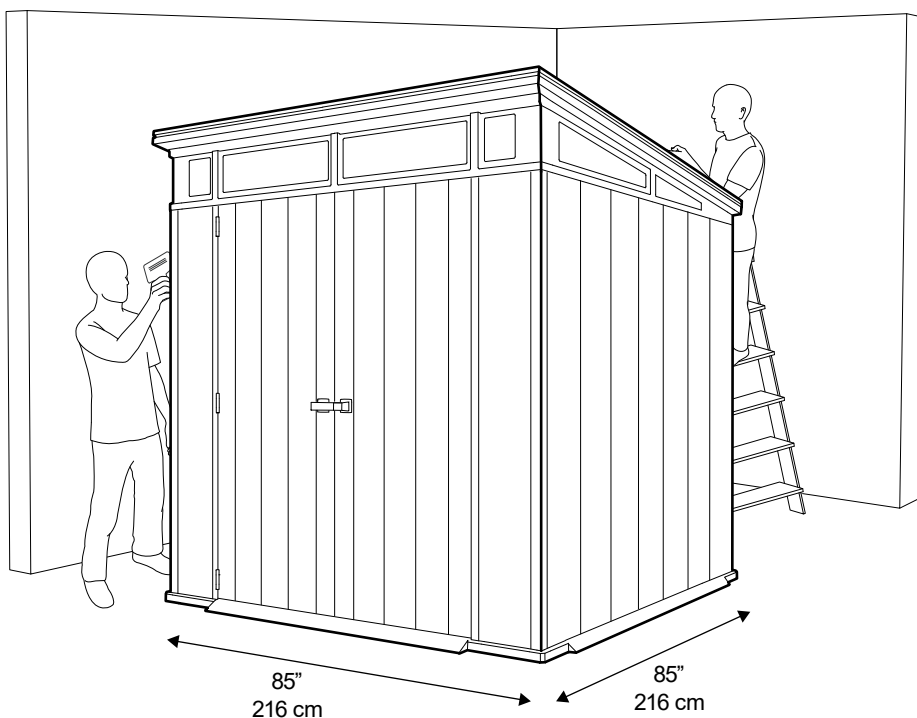

BEFORE STARTING ASSEMBLY | AVANT DE COMMENCER LE MONTAGE | ANTES DE EMPEZAR EL ARMADO | VOR MONTAGEBEGINN | VOORDAT U BEGINT TE MONTEREN | PRIMA DI INIZIARE IL MONTAGGIO | ANTES DE INICIAR A MONTAGEM

Read the care and safety guidelines at the end of this manual | Check to ensure that there are no missing or damaged parts BEFORE starting or arranging assembly | Review all assembly instructions | Assemble all the parts according to the directions in this manual. Do not skip any steps.

Lisez les instructions de précaution et de sécurité à la fin de ce manuel | Assurez-vous qu'il n'y a pas de pièces manquantes ou endommagées AVANT de commencer ou d'organiser l'assemblage | Lisez toutes les instructions de montage | Assemblez toutes les pièces selon les instructions de ce manuel. Ne sautez aucune étape.

Lea las instrucciones de precauciones y seguridad que están al final de este manual | Asegúrese de que no faltan piezas ni están dañadas ANTES de comenzar o disponer el montaje | Revise todas las instrucciones de montaje | Monte todas las piezas según las instrucciones de este manual. No se saltee ningún paso.

Lesen Sie die Sicherheitsrichtlinien am Ende des Benutzerhandbuchs durch | Prüfen Sie bitte VOR dem Zusammenbau, dass keine Teile beschädigt sind oder fehlen | Gehen Sie noch einmal die komplette Aufbauanleitung durch | Bauen Sie alle Teile entsprechend der Anleitung in diesem Handbuch zusammen. Lassen Sie dabei keinen Arbeitsschritt aus.

Lees de richtlijnen voor zorg en veiligheid achterin deze handleiding | Controleer dat er geen onderdelen mankeren, of beschadigd zijn, VOORDAT u met de montage begint | Bekijk alle montagehandleidingen | Monteer alle onderdelen volgens de aanwijzingen van deze handleiding. Sla geen stappen over.

Leggi le linee guida di assistenza e sicurezza alla fine di questo manuale | Verificare per assicurarsi che non ci siano parti mancanti o danneggiate PRIMA di iniziare o di disporre il montaggio | Consulta tutte le istruzioni di montaggio | Monta tutti i componenti secondo le istruzioni contenute in questo manuale. Non saltare nessuna fase.

Leia as diretrizes de cuidados e segurança que constam da parte final deste manual | Verifique para se assegurar de que não há peças em falta ou danificadas ANTES de começar a preparar a montagem | Reveja todas as instruções de montagem | Monte todas as peças de acordo com as instruções do manual. Não salte quaisquer passos.

REQUIRED TOOLS | OUTILS EXIGÉS | HERRAMIENTAS NECESARIAS | BENÖTIGTE WERKZEUGE | BENODIGD GEREEDSCHAP | ATTREZZATURA OCCORRENTE | FERRAMENTAS NECESSÁRIAS

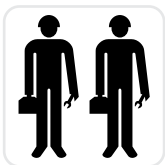
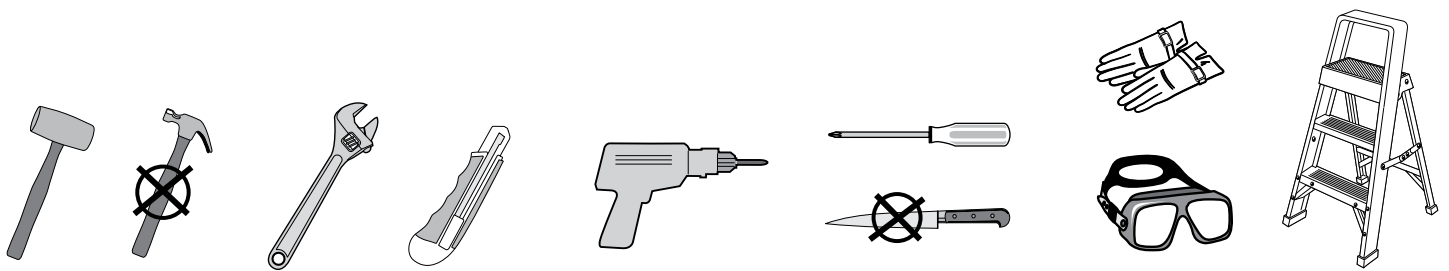

ASSEMBLY REQUIRES TWO PEOPLE | LE MONTAGE DOIT ÊTRE EFFECTUÉ PAR DEUX PERSONNES | SE NECESITAN DOS PERSONAS PARA ARMARLO | ZWEI PERSONEN ZUR MONTAGE NOTWENDIG | MONTAGE VEREIST TWEETWEE PERSONEN | MONTAGGIO RICHIEDE DUE PERSONE | A MONTAGEM EXIGE DUAS PESSOAS

SHED PARTS | PIÈCES DE L'ABRI | PARTES DEL COBERTIZO | TEILE DES SCHUPPENS | ONDERDELEN VAN HET SCHUURTJE | COMPONENTI DEL DEPOSITO ATTREZZI | PEÇAS DO ABRIGO

Remove all parts from the package(s) and spread them out on a clean work surface | Code letters are imprinted on each part for easy identification | Retirez toutes les pièces du/des paquet(s) et étalez-les sur une surface de travail propre | Des lettres sont imprimées sur chaque pièce pour une identification facile | Saque todas las piezas del paquete o paquetes y póngalas sobre una superficie de trabajo limpia | El código de letras está marcado en cada pieza para que sea más fácil identificarla | Nehmen Sie alle Teile aus der Verpackung und breiten Sie sie auf einer sauberen Arbeitsfläche aus | Auf jedem Teil sind Kennbuchstaben aufgedruckt, die die Zuordnung der einzelnen Teile erleichtern | Haal alle onderdelen uit het pakket (of uit de pakketten) en leg ze op een schoon werkoppervlak | Op ieder onderdeel zijn codes aangebracht voor een gemakkelijke identificatie | Rimuovi tutti i componenti dal pacchetto (i) e spargili su una superficie di lavoro pulita | Le lettere del codice sono state stampate su ciascun componente per una facile identificazione | Retire todas as peças da embalagem e espalhe-as numa superfície de trabalho limpa | Existem letras de código impressas em cada peça para fácil identificação

FLOOR PARTS | ÉLÉMENTS DU PLANCHER | PARTES DEL SUELO | BODENTEILE | VLOERPANELEN | PARTI DEL PAVIMENTO | PEÇAS DO CHÃO

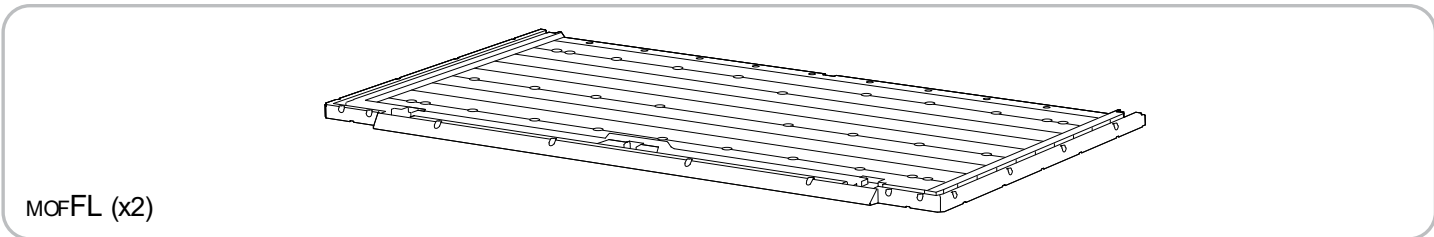

WALL PARTS | PIÈCES DU CONTOUR | PARTES DE LAS PAREDES | WANDELEMENTE | MUURONDERDELEN | PARTI DELLA PARETE | PAINÉIS LATERAIS

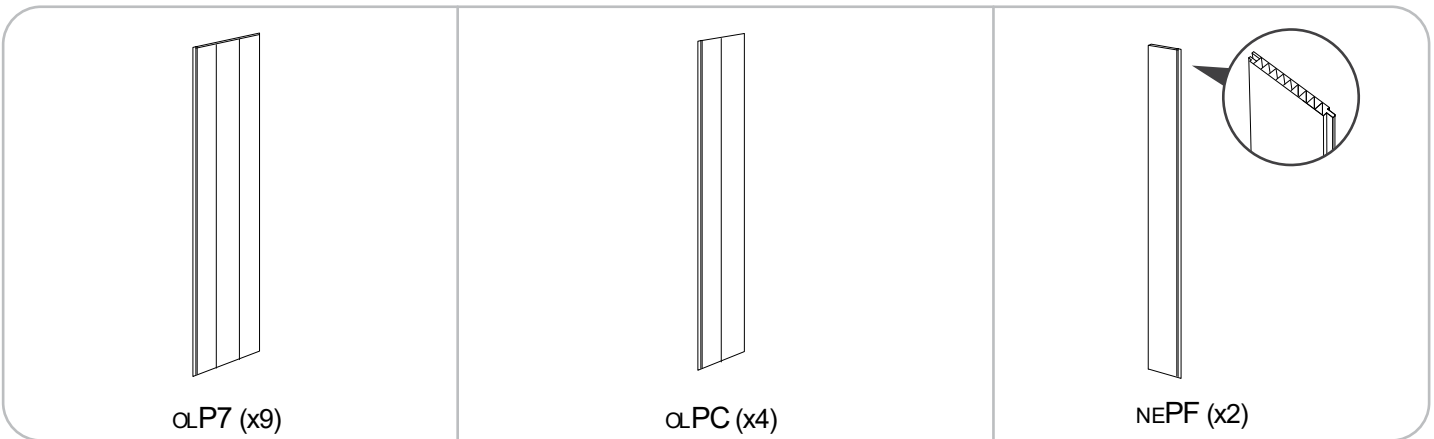

DOOR PARTS | PIÈCES DE LA PORTE | PARTES DE LA PUERTA | TÜRELEMENTE | DEURONDERDELEN | PARTI DELLA PORTA | PEÇAS DAS PORTAS

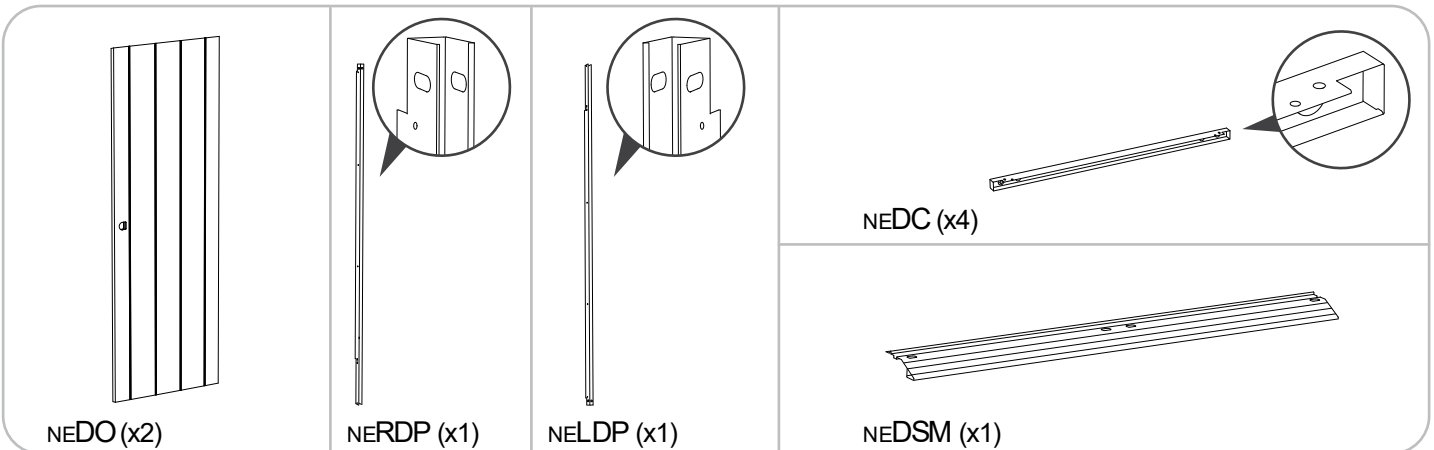

ROOF PARTS | PIÈCES DU TOIT | PARTES DEL TECHO | DACHELEMENTE | DAKONDERDELEN | PARTI DEL TETTO | PEÇAS DO TELHADO

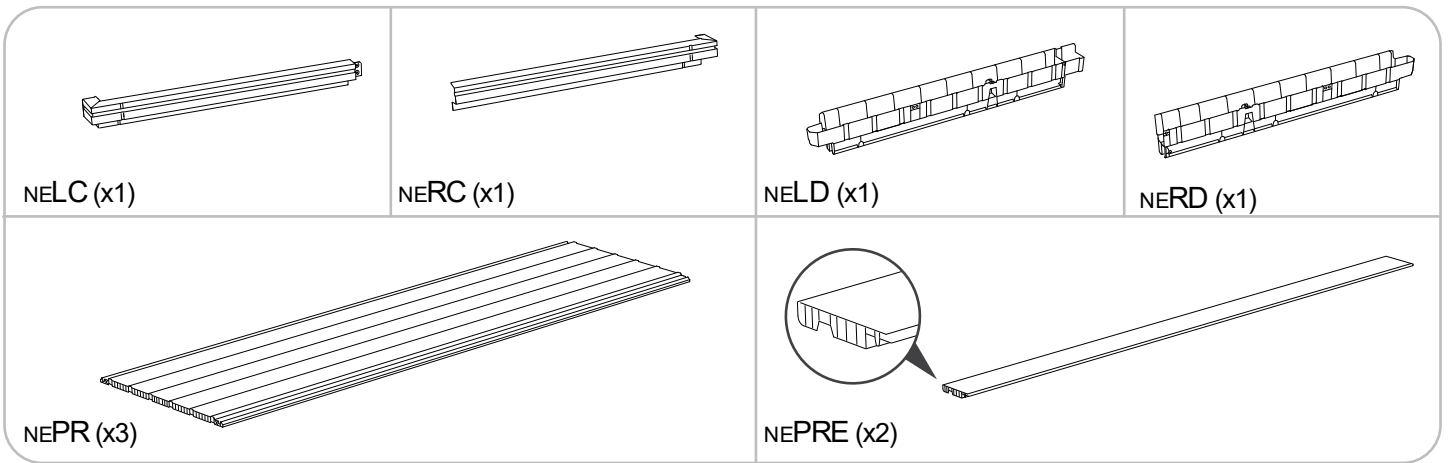

METAL PARTS | PIÈCES MÉTALLIQUES | PIEZAS METÁLICAS | METALLTEILE | METALEN DELEN | PARTI IN METALLO | PARTES METÁLICAS

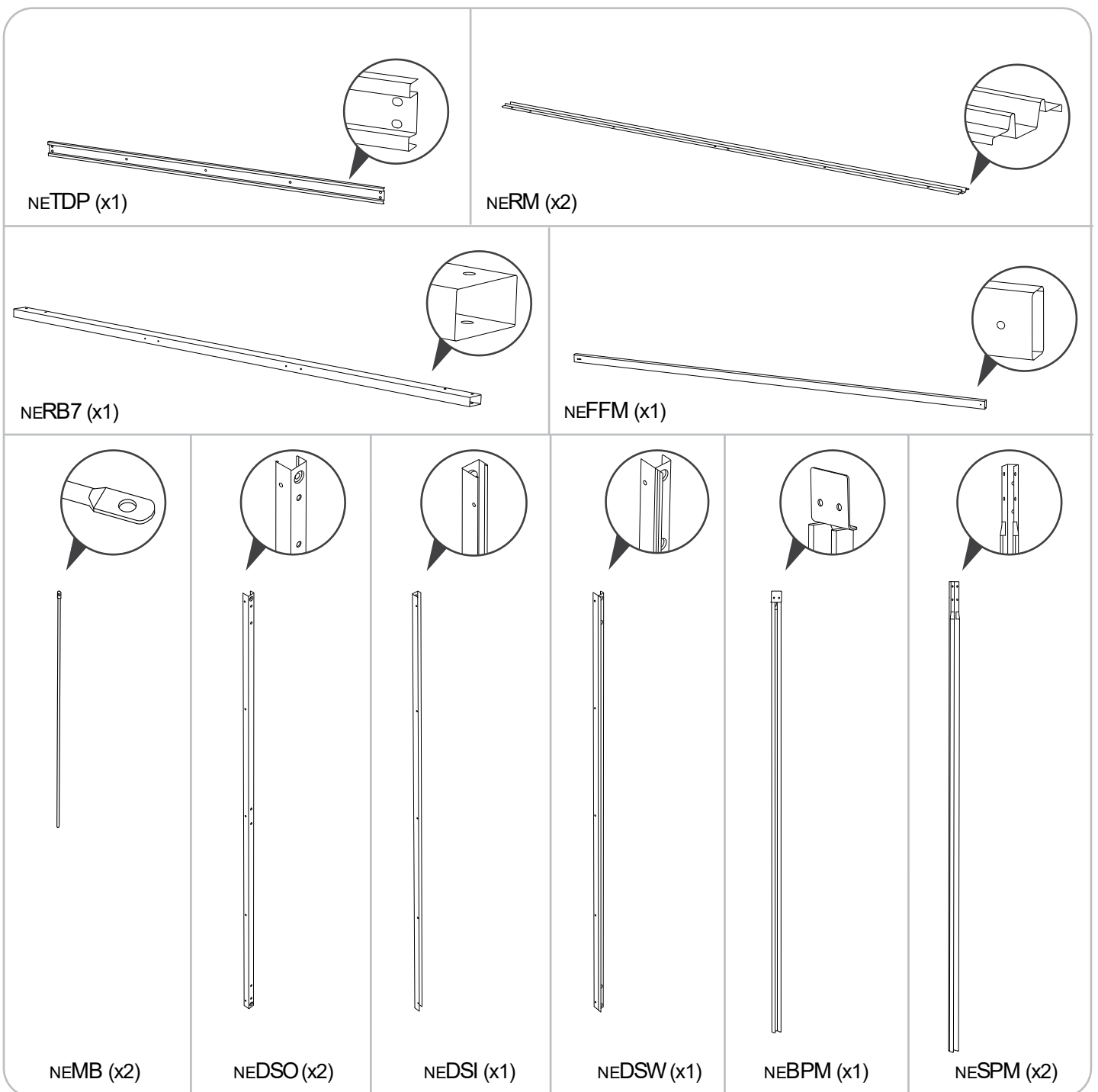

WINDOW PARTS | PIÈCES DE LA FENÊTRE | PARTES DE LA VENTANA | FENSTERELEMENTE | VENSTERONDERDELEN | PARTI DELLA FINESTRA | PEÇAS DA JANELA

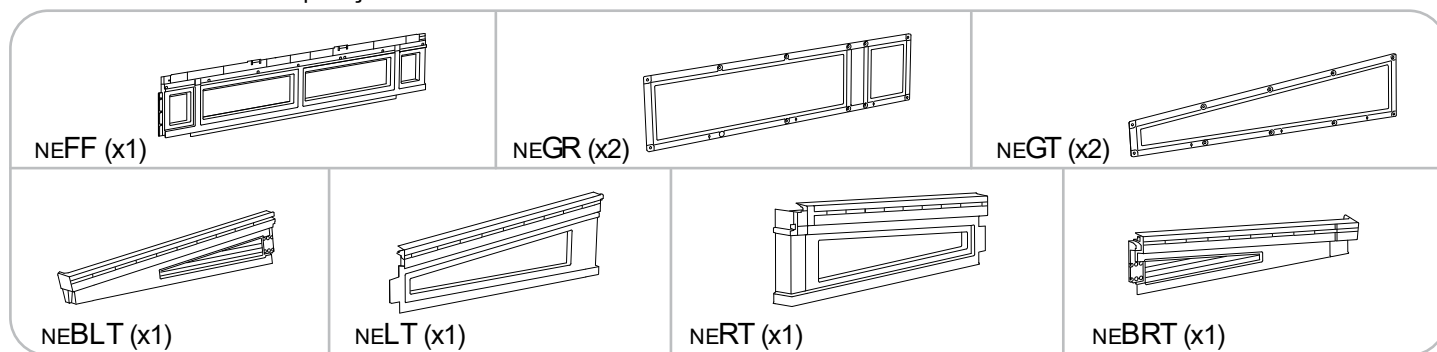

SMALL PARTS | PETITES PIÈCES | PARTES PEQUEÑAS | KLEINTEILE | KLEINE ONDERDELEN | MINUTERIA | PEÇAS PEQUENAS

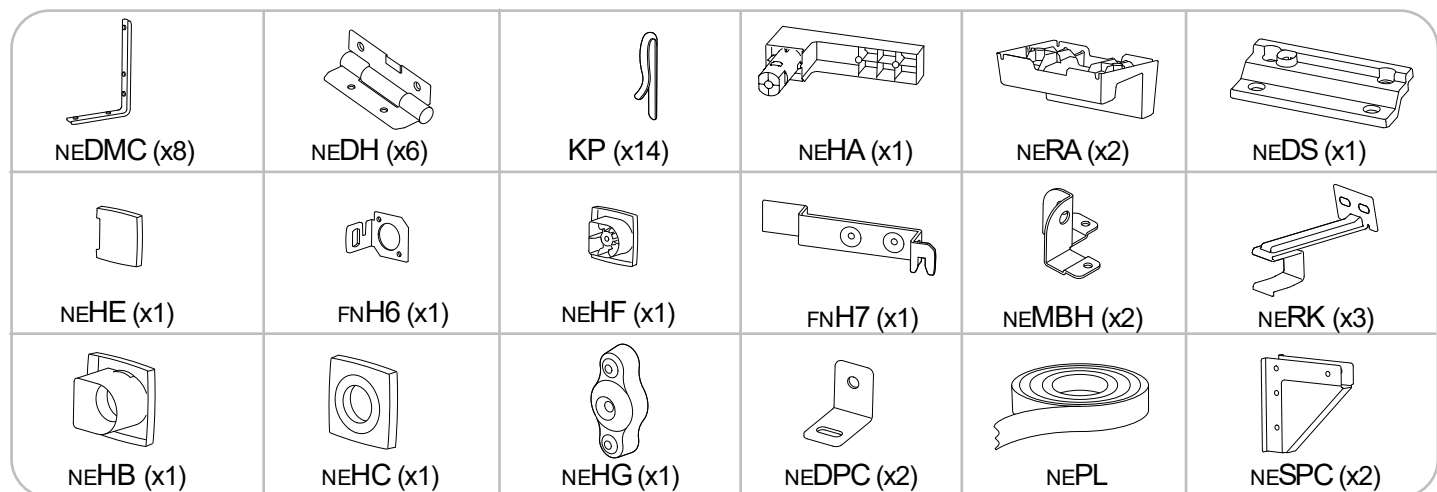

SCREWS | VIS | TORNILLOS | SCHRAUBEN | SCHROEVEN | VITI | PARAFUSOS

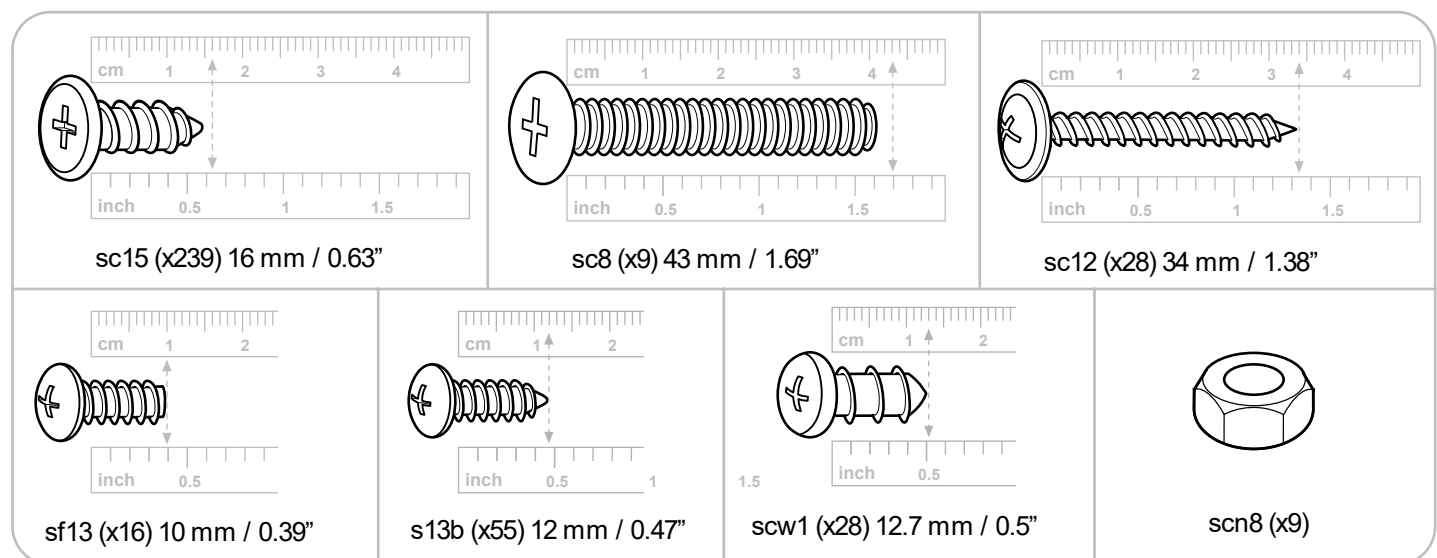

Packaging may contain some additional small parts for use as spare parts | L'emballage peut contenir de petites pièces supplémentaires à utiliser comme pièces de rechange | El envoltorio puede contener algunas piezas pequeñas adicionales que se pueden utilizar como repuestos | In der Verpackung können kleine Zusatzteile enthalten sein, die als Ersatzteile genutzt werden können | De verpakking kan een aantal kleine extra onderdelen bevatten, die als reserveonderdeel gebruikt kunnen worden | La confezione potrebbe contenere piccole parti supplementari da utilizzare come parti di ricambio | A embalagem pode conter algumas pequenas peças adicionais para utilização como peças de reposição

**NOTE:** Due to variations in production, the actual assembled size may vary slightly from the specified dimensions.

**REMARQUE:** En raison de variantes dans la production, la taille de montage réelle peut différer quelque peu des dimensions indiquées.

**NOTA:** debido a las variaciones en la producción, el tamaño real al montarlo puede variar ligeramente con respecto a las dimensiones especificadas.

**BITTE BEACHTEN:** Aufgrund von Abweichungen in der Herstellung kann die tatsächliche Größe leicht von den angegebenen Maßen abweichen.

**LET OP:** vanwege afwijkingen in de productie kan de werkelijke afmeting na montage een klein beetje afwijken van de opgegeven afmetingen.

**NOTA:** a causa di variazioni nella produzione, la dimensione effettiva del prodotto assemblato può variare leggermente dalle dimensioni menzionate.

**NOTA:** Devido a variações na produção o tamanho real da montagem poderá variar ligeiramente das dimensões especificadas.

1

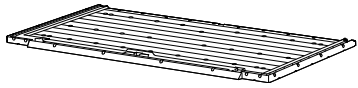

MOFL (x2)

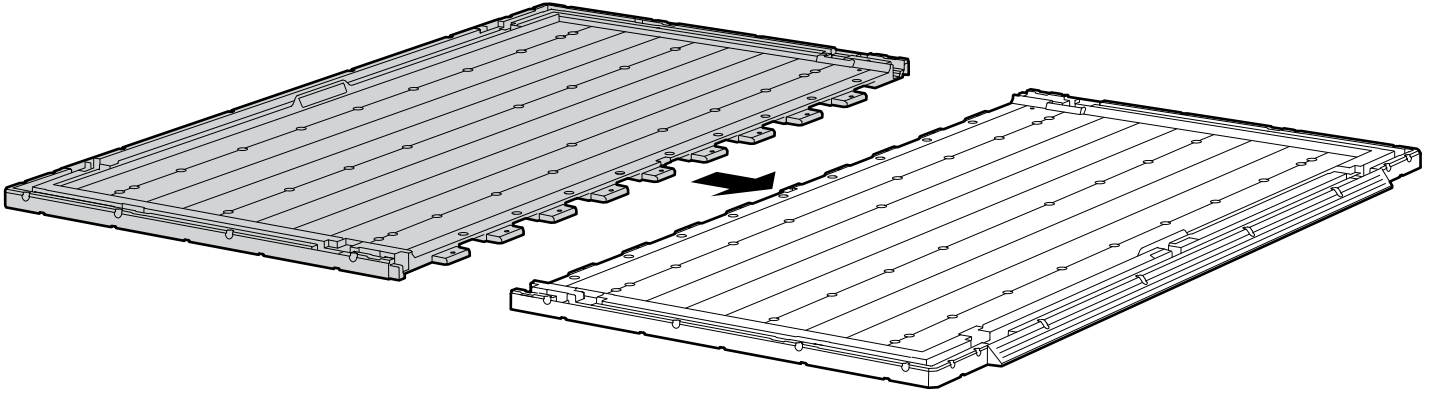

2

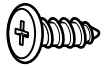

sc15 (x18)

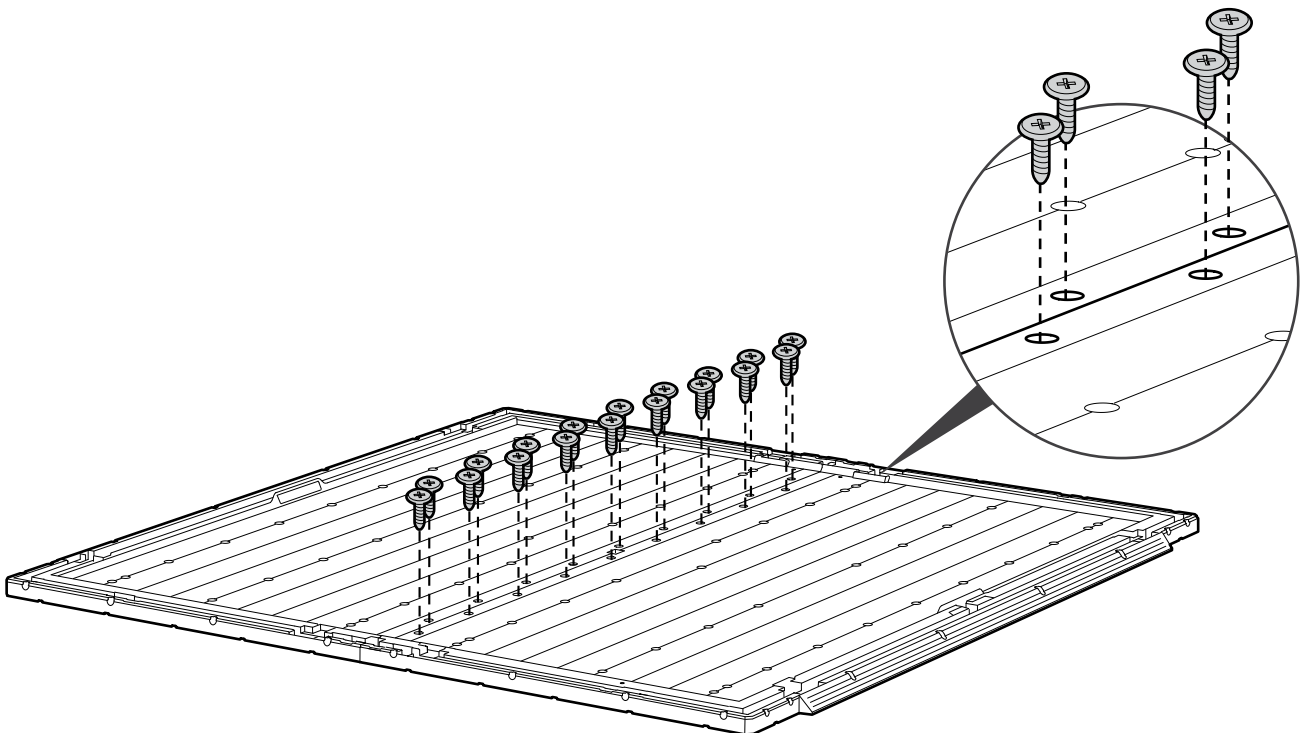

3



NEDSM (x1)

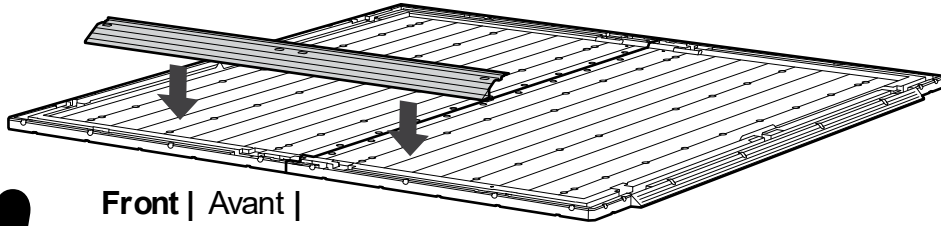

**!** Front | Avant |  
Delante | Vorderseite |  
Voorkant | Anteriore  
| Frente

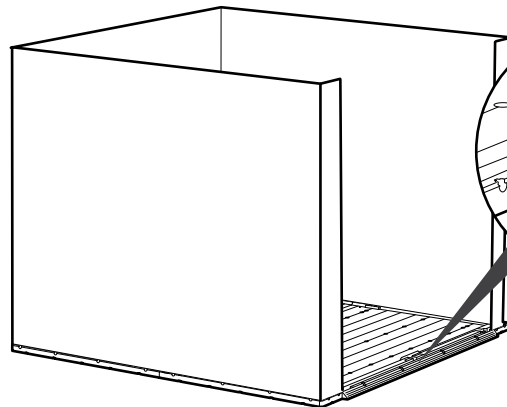
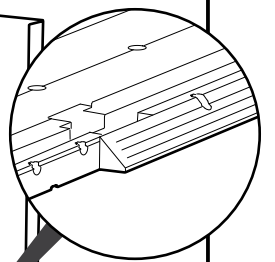
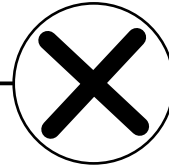
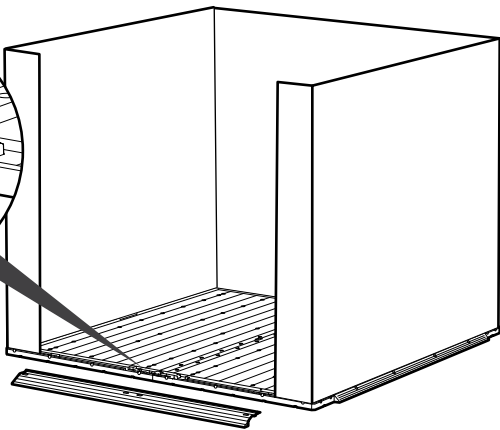
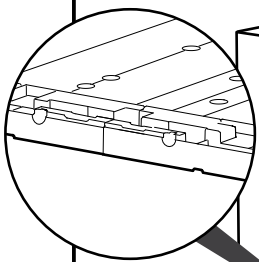
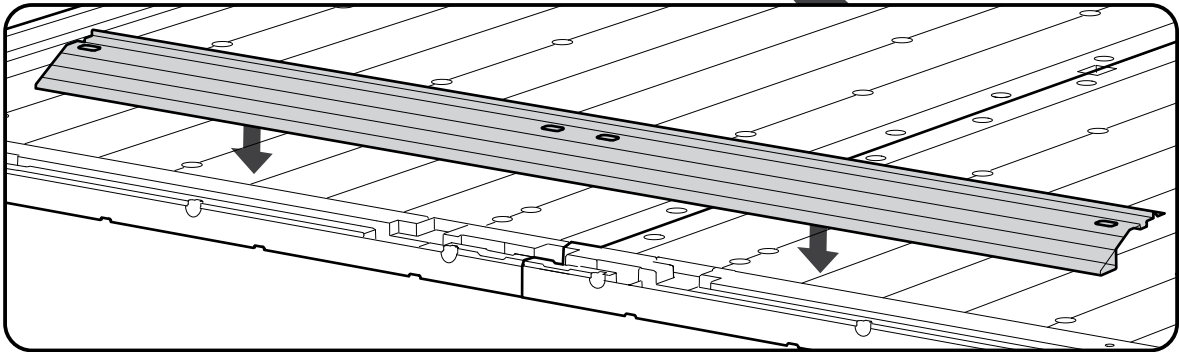



4

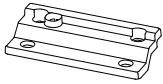

nEDS (x1)



sc15 (x2)

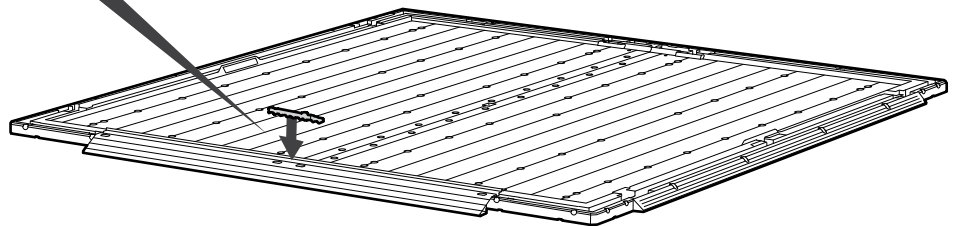
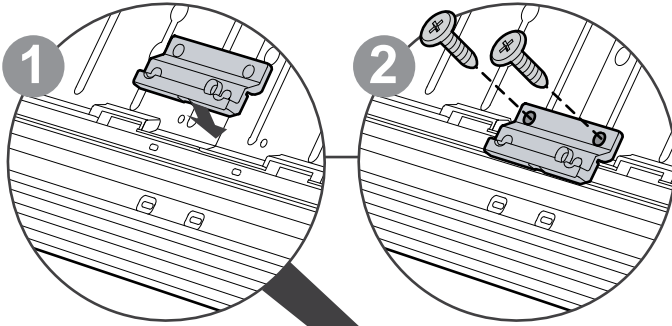

WALL ASSEMBLY | MONTAGE DU MUR | ARMADO DE PAREDES | MONTAGE DER WÄNDE | MONTAGE VAN DE MUREN | ASSEMBLAGGIO DELLE PARETI | MONTAGEM DA PAREDE

5



αPC (x1)



αP7 (x1)

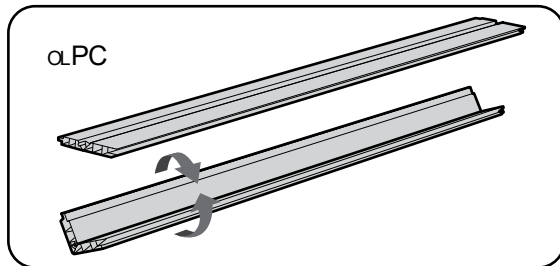

αPC

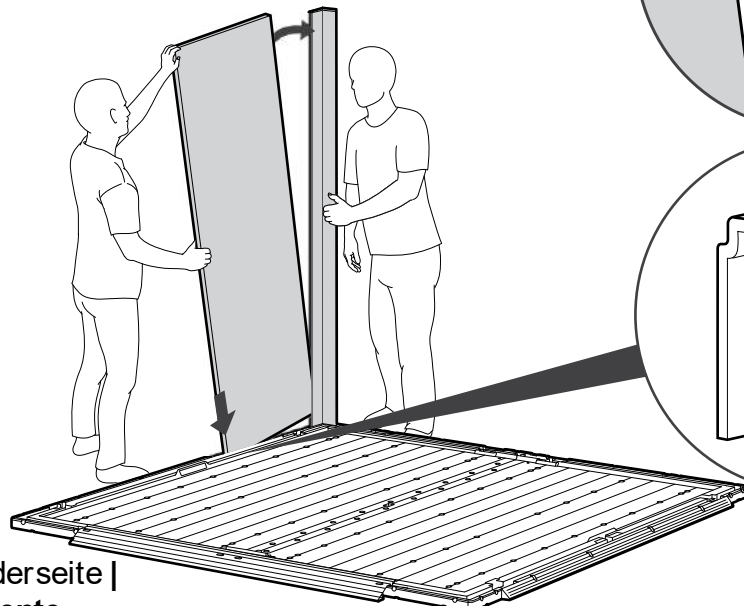
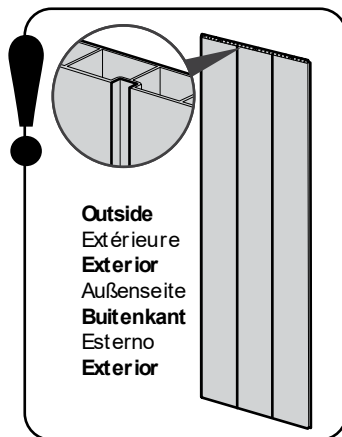
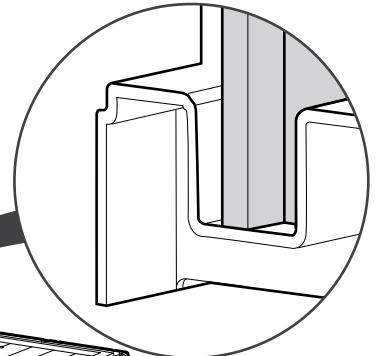
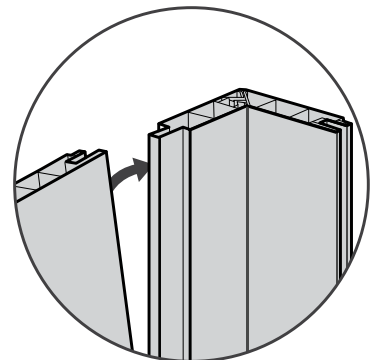

**Front** | Avant | **Delante** | Vorderseite |  
**Voorkant** | Anteriore | **Frente**

6



KP (x1)



s13b (x1)

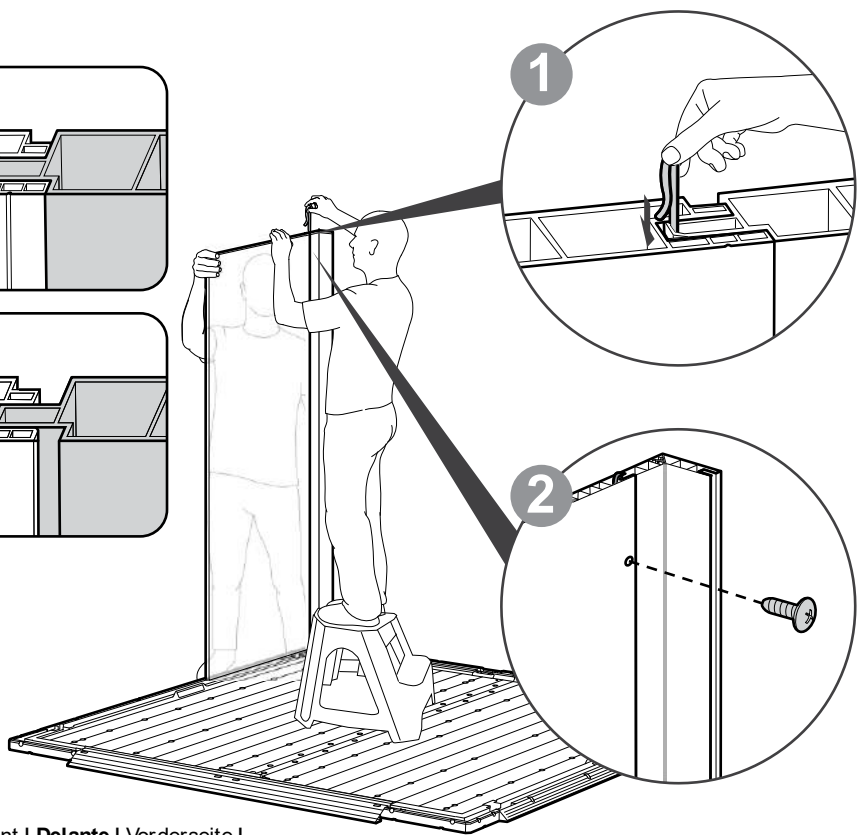
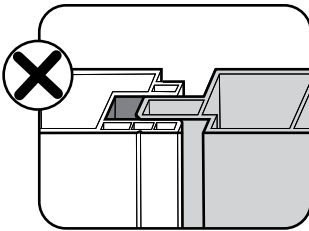
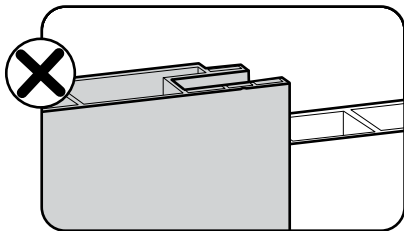
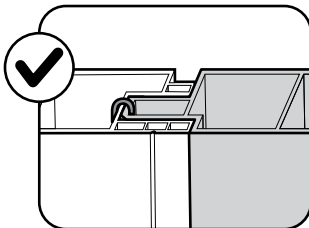
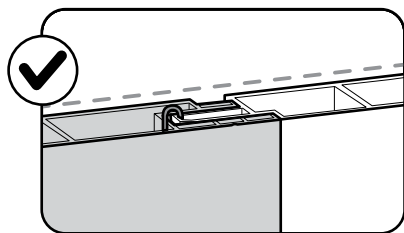

Front | Avant | Delante | Vorderseite |  
Voorkant | Anteriore | Frente

7



oLP7 (x1)

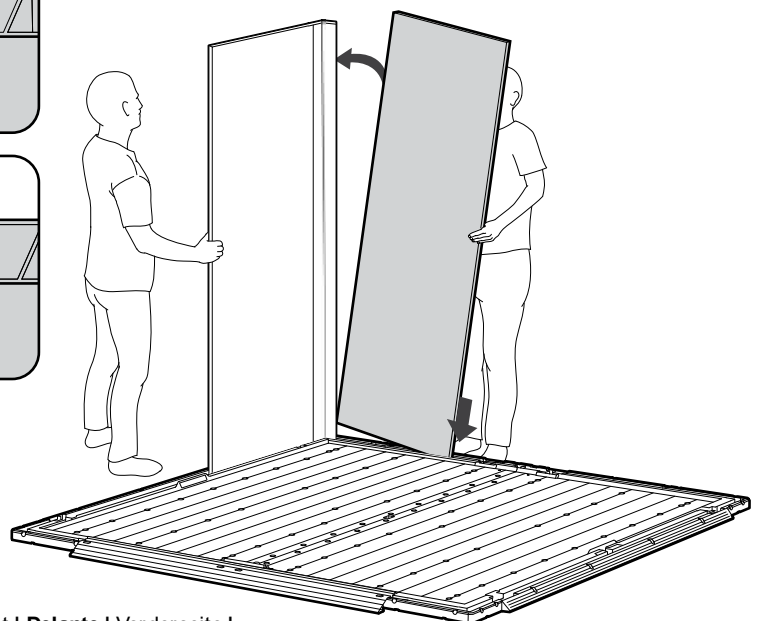
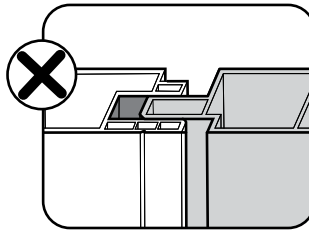
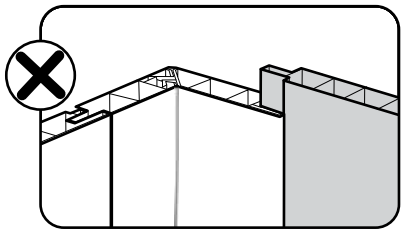
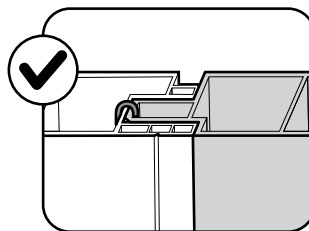
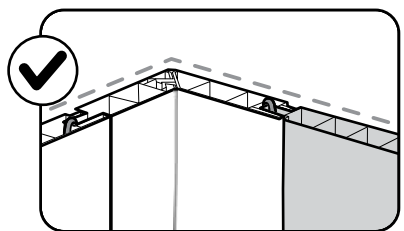

Front | Avant | Delante | Vorderseite |  
Voorkant | Anteriore | Frente

8



KP (x1)

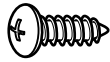

s13b (x1)

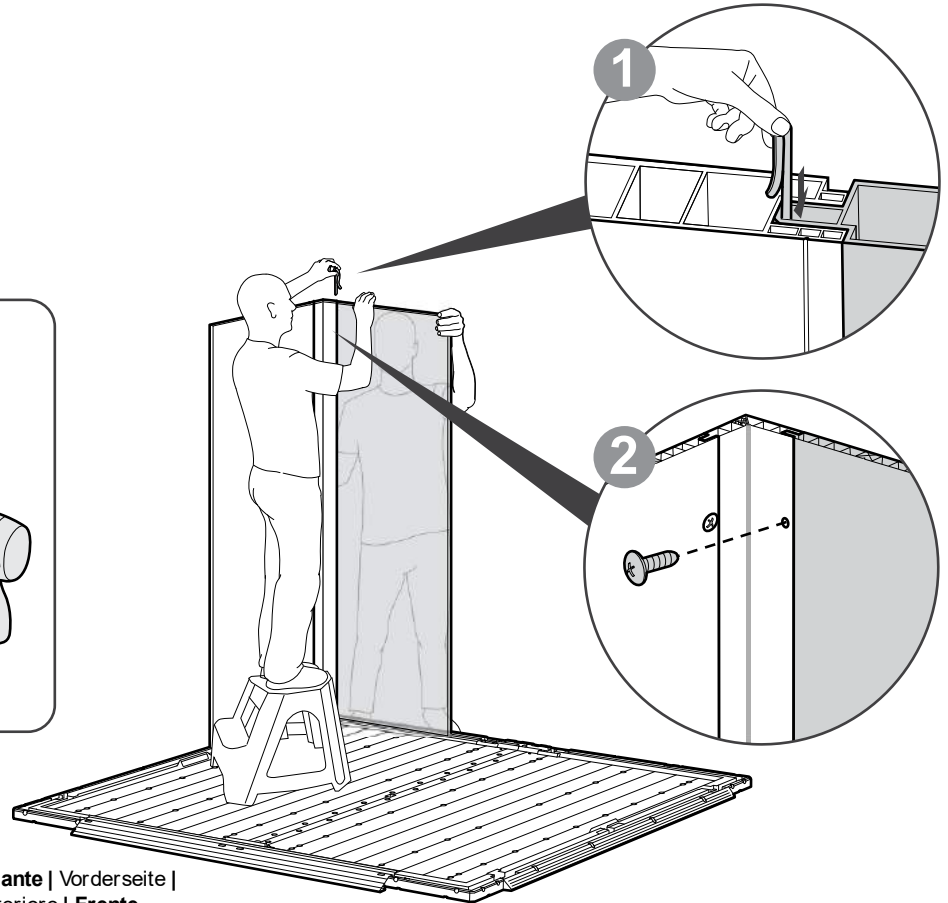
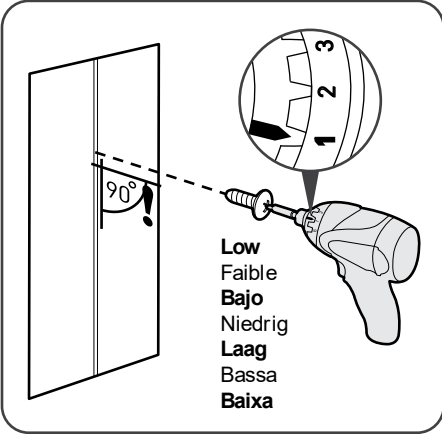
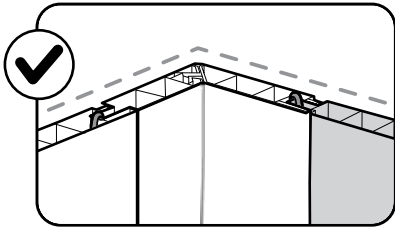

Front | Avant | Delante | Vorderseite |  
Voorkant | Anteriore | Frente

9



αLP7 (x2)



KP (x2)

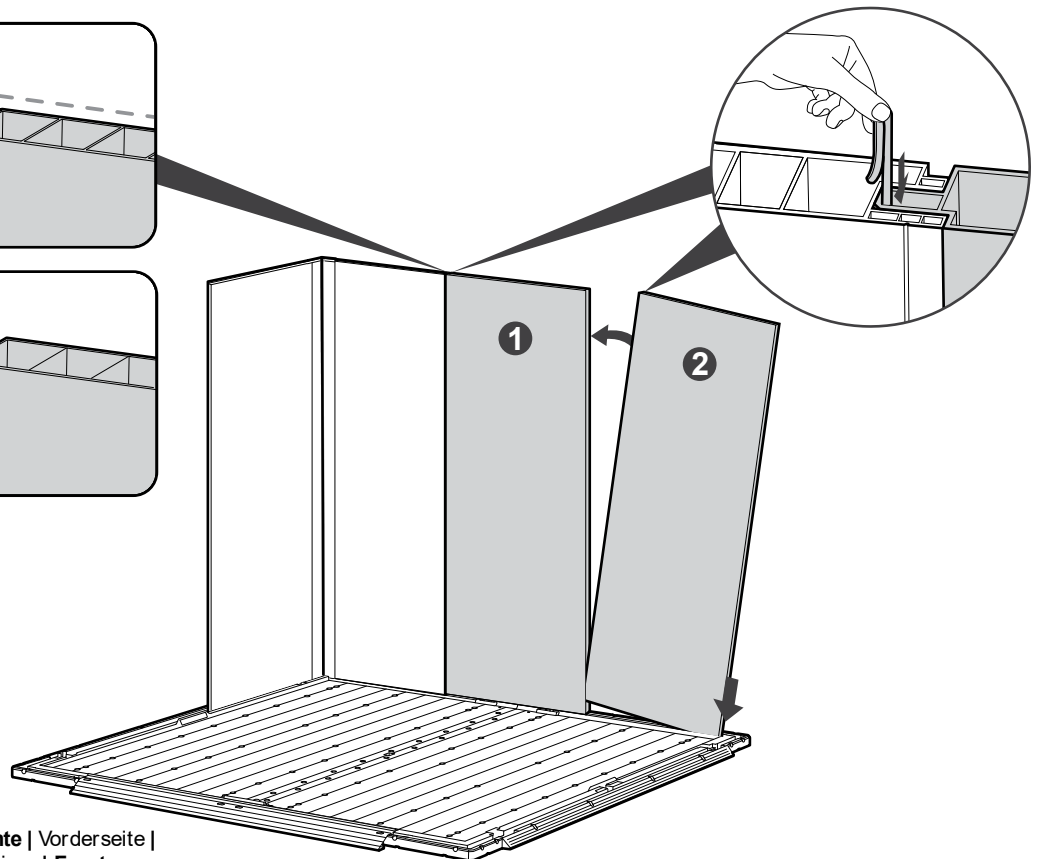
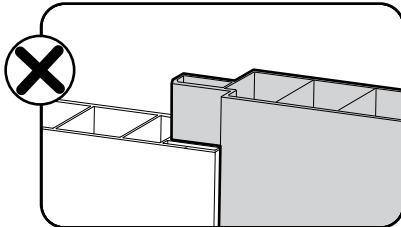
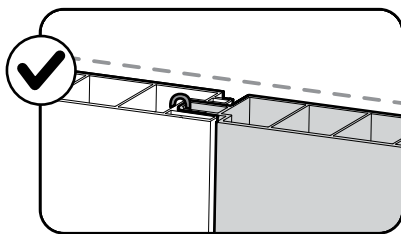

Front | Avant | Delante | Vorderseite |  
Voorkant | Anteriore | Frente

10



αLPC (x1)



KP (x1)



s13b (x1)

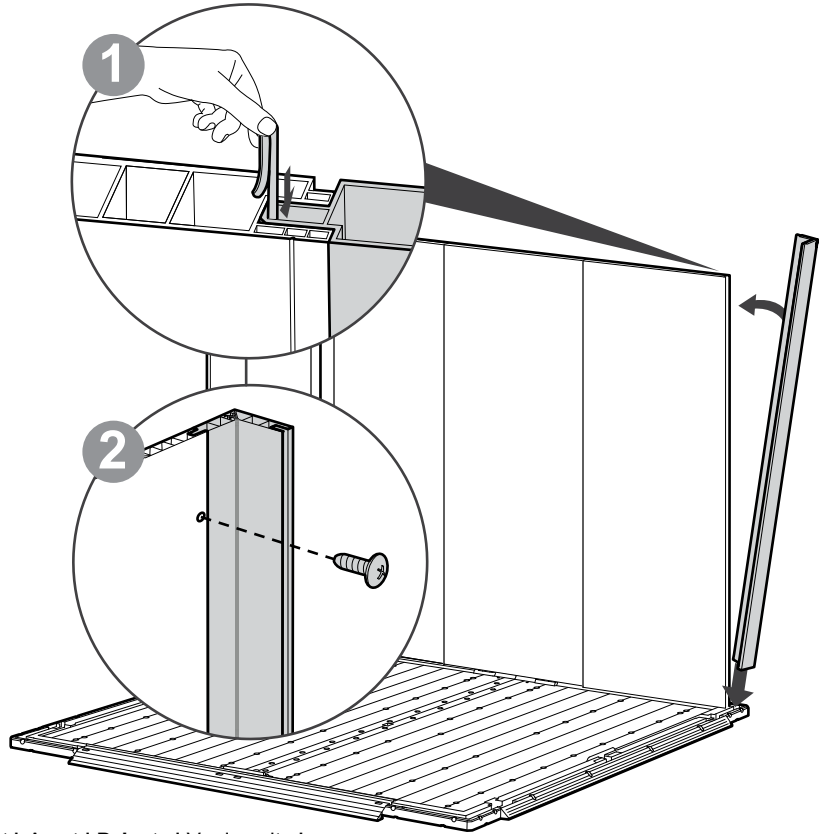
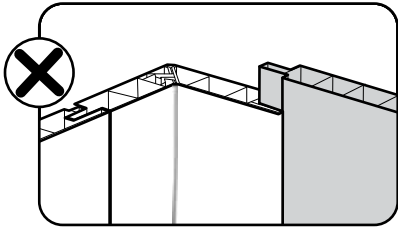
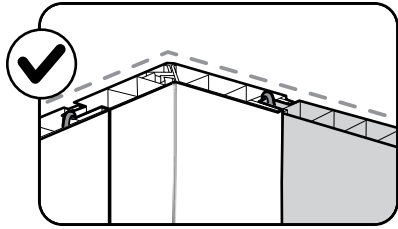
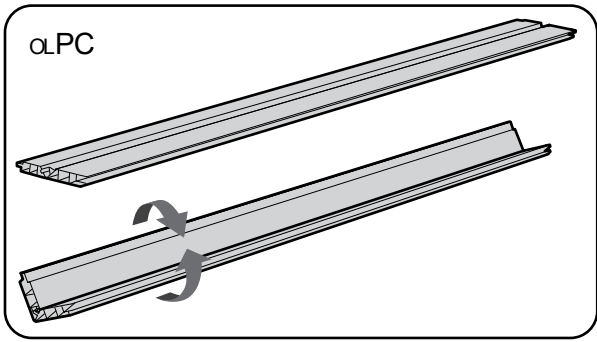

Front | Avant | **Delante** | Vorderseite |  
Voorkant | Anteriore | **Frente**

11



αLP7 (x1)



KP (x1)



s13b (x1)

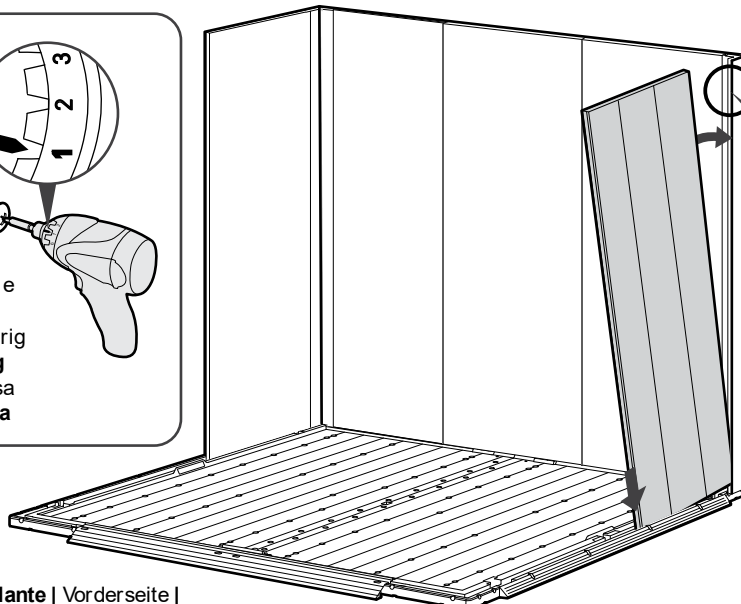
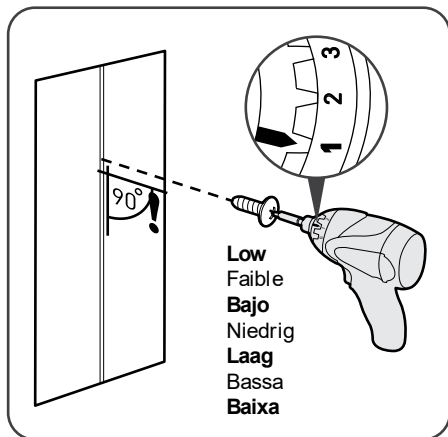
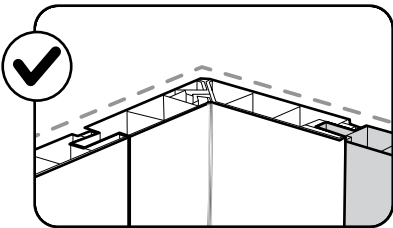

Front | Avant | **Delante** | Vorderseite |  
Voorkant | Anteriore | **Frente**

12



α.P7 (x2)



KP (x2)

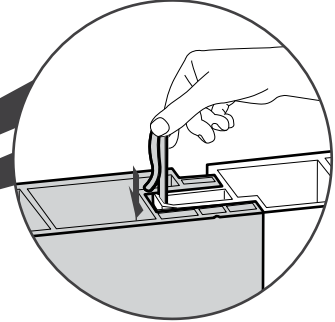
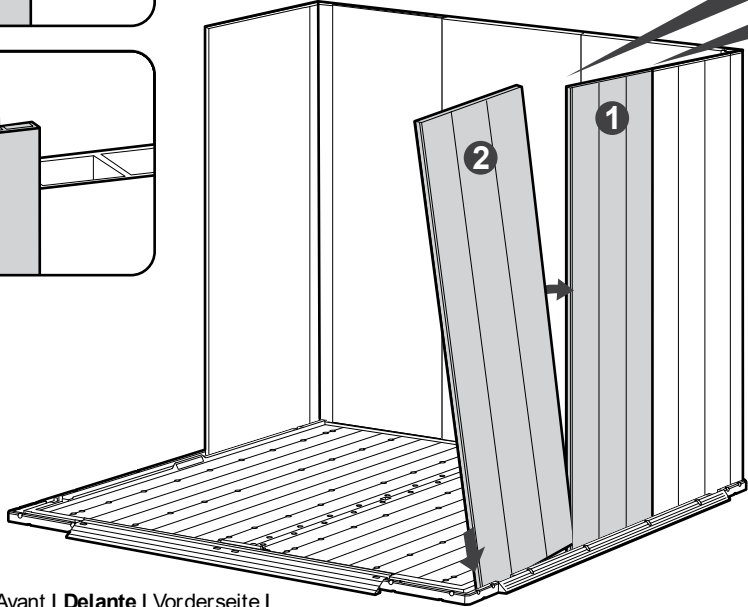
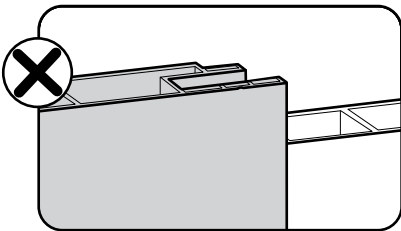
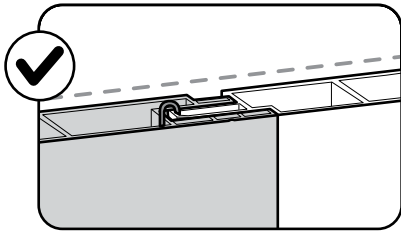

Front | Avant | Delante | Vorderseite |  
Voorkant | Anteriore | Frente

13



α.PC (x1)



KP (x1)

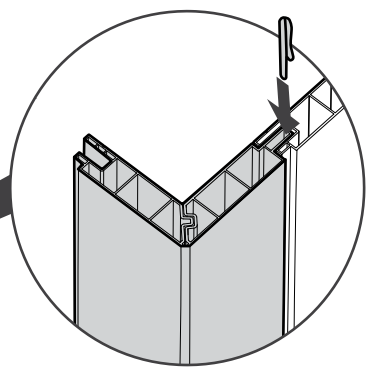
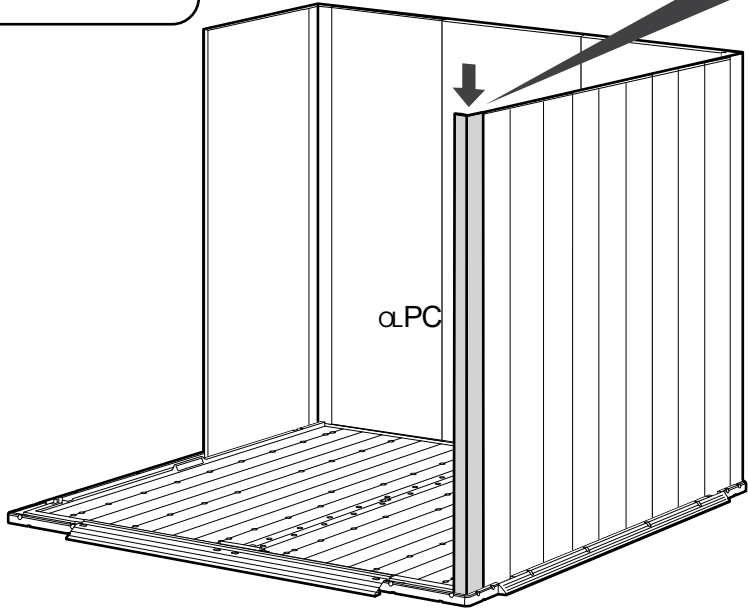
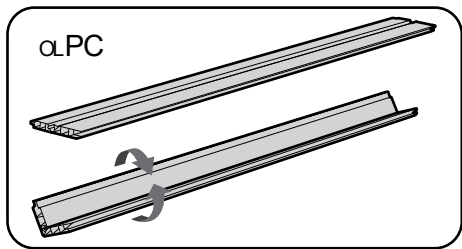

Front | Avant | Delante | Vorderseite |  
Voorkant | Anteriore | Frente

14

 s13b (x2)

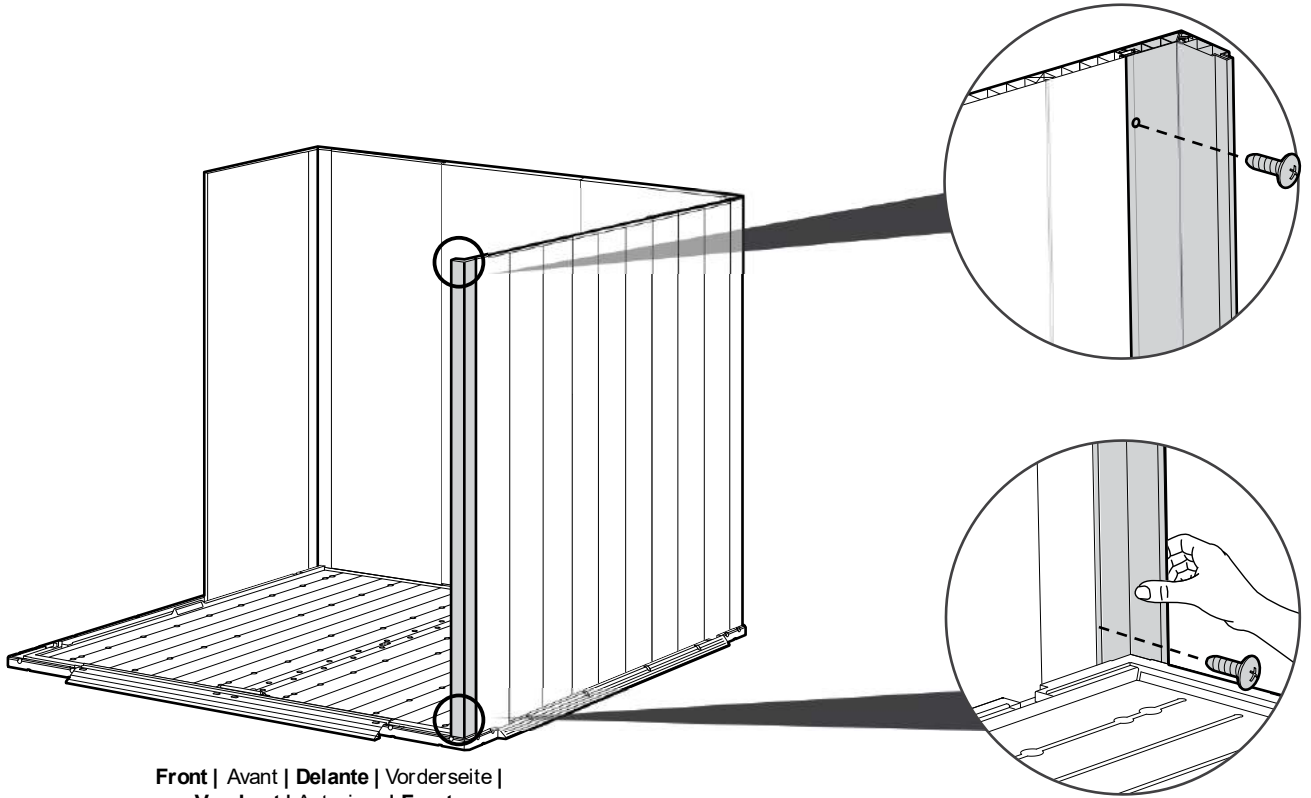

Front | Avant | Delante | Vorderseite |  
Voorkant | Anteriore | Frente

15



αLP7 (x2)



KP (x2)

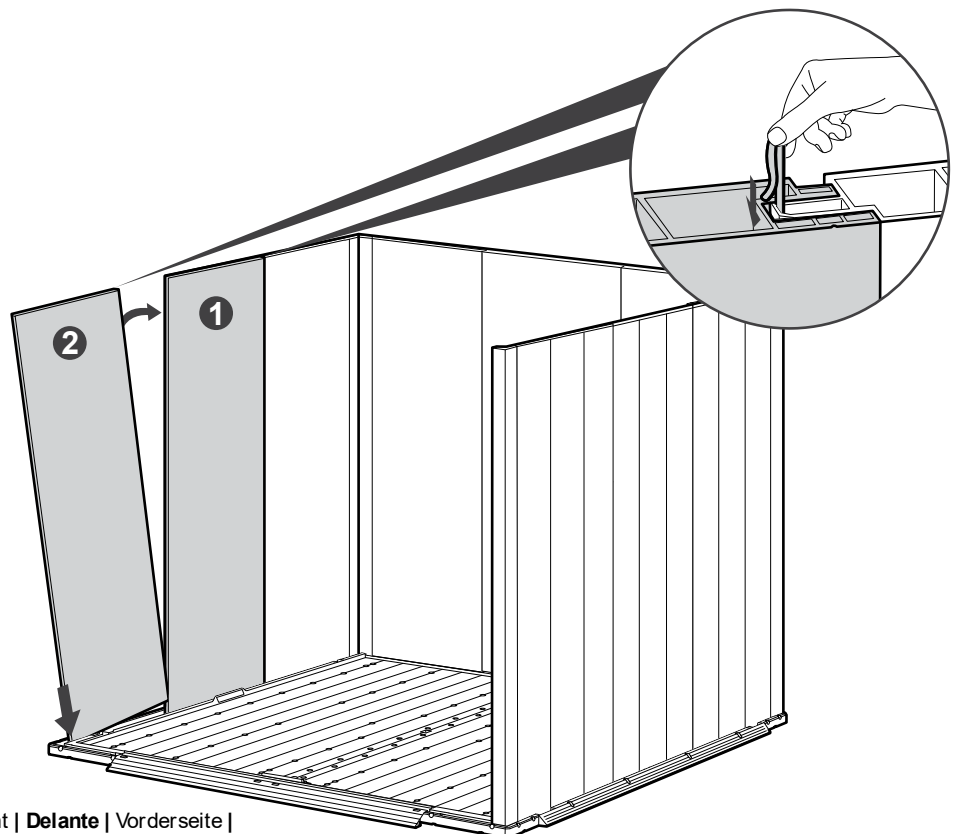
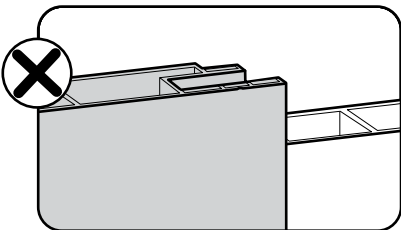
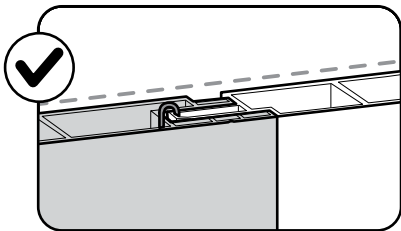

Front | Avant | Delante | Vorderseite |  
Voorkant | Anteriore | Frente

16

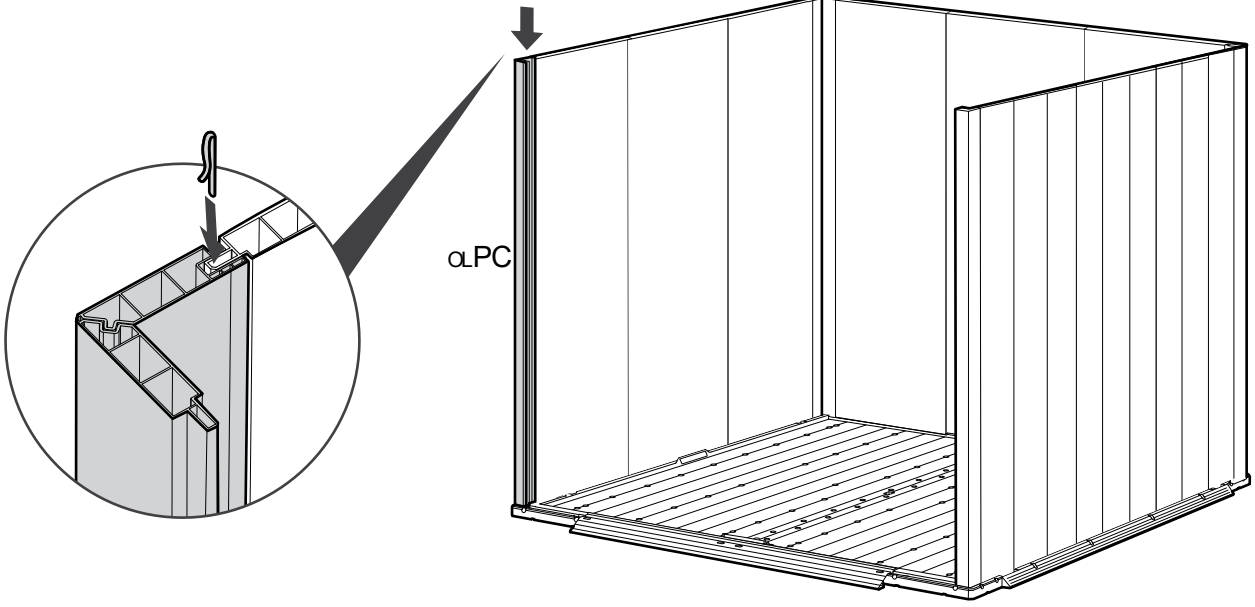
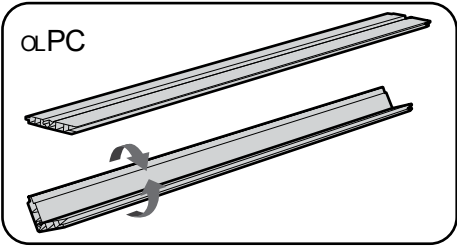
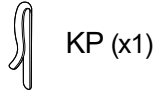

17

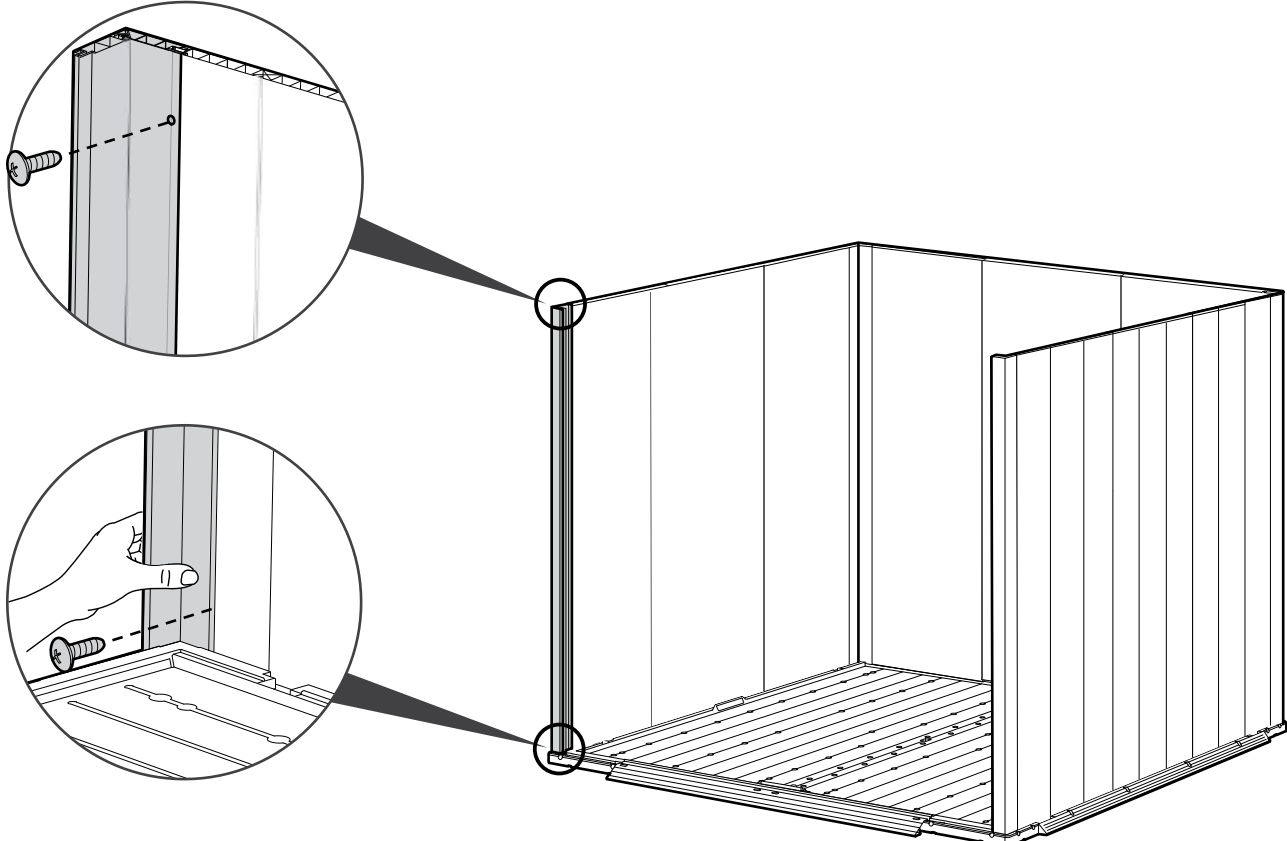
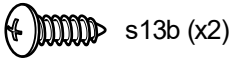

18



NEPF (x2)



KP (x2)

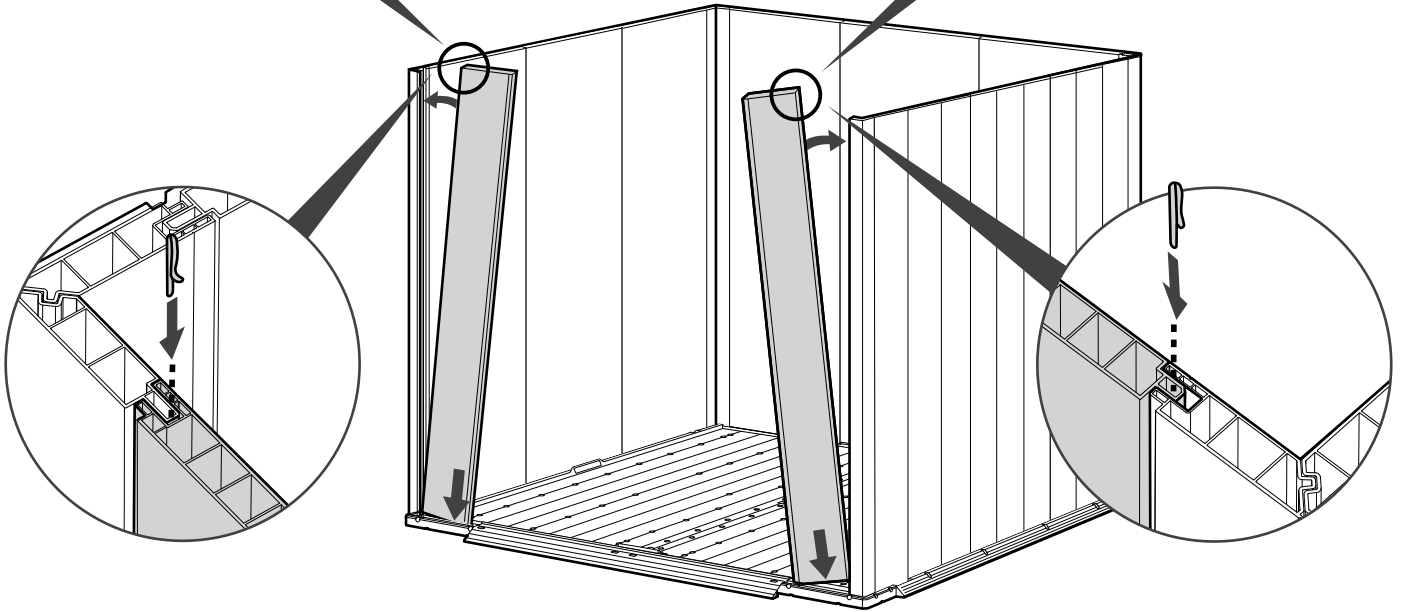
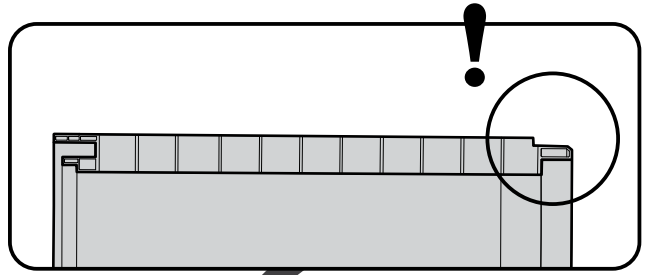
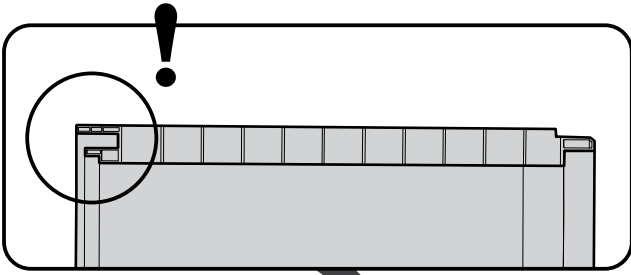

19



s13b (x4)

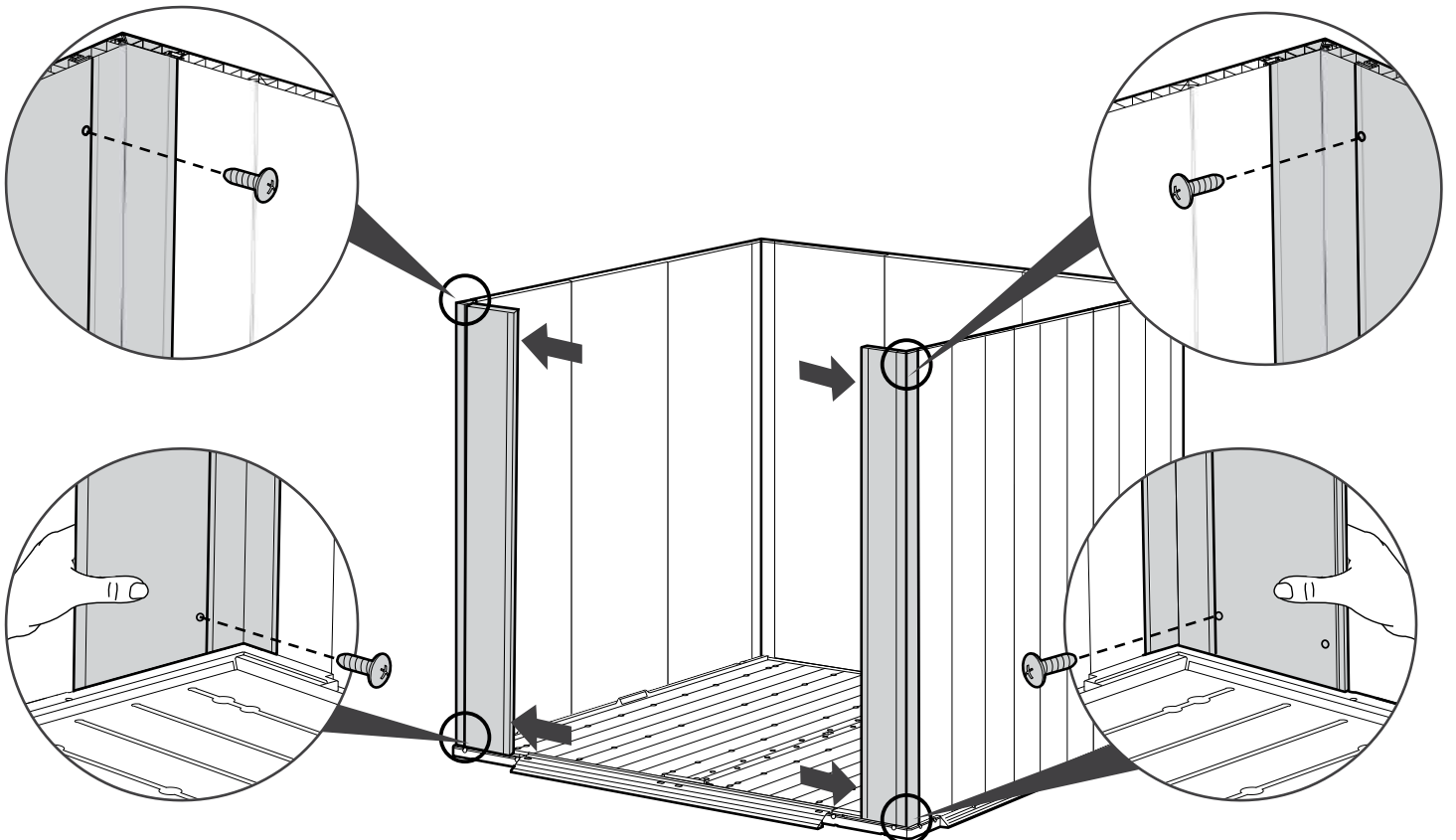



20

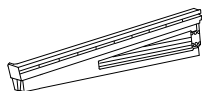

NEBLT (x1)



NELT (x1)



sc15 (x5)

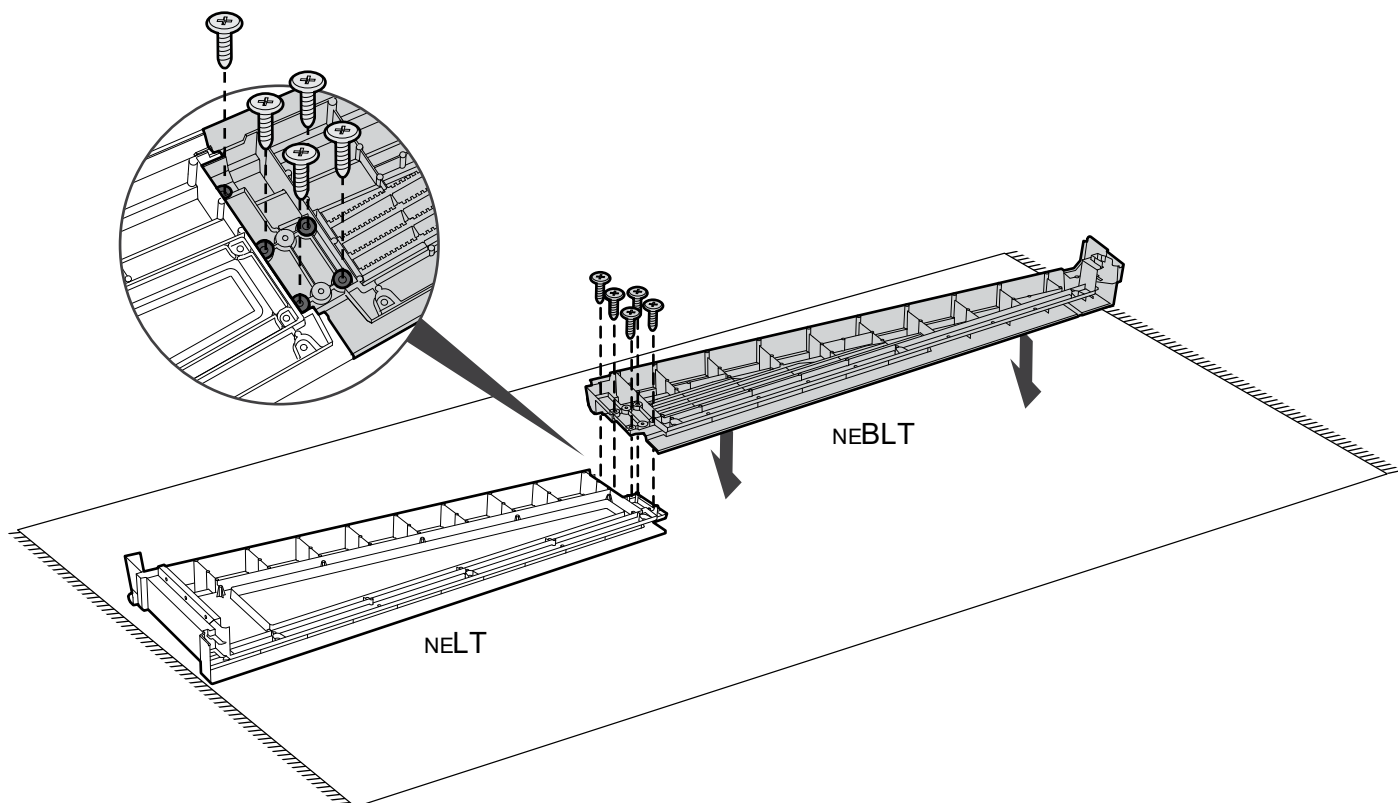

21

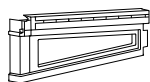

NERT (x1)

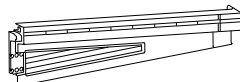

NEBRT (x1)



sc15 (x5)

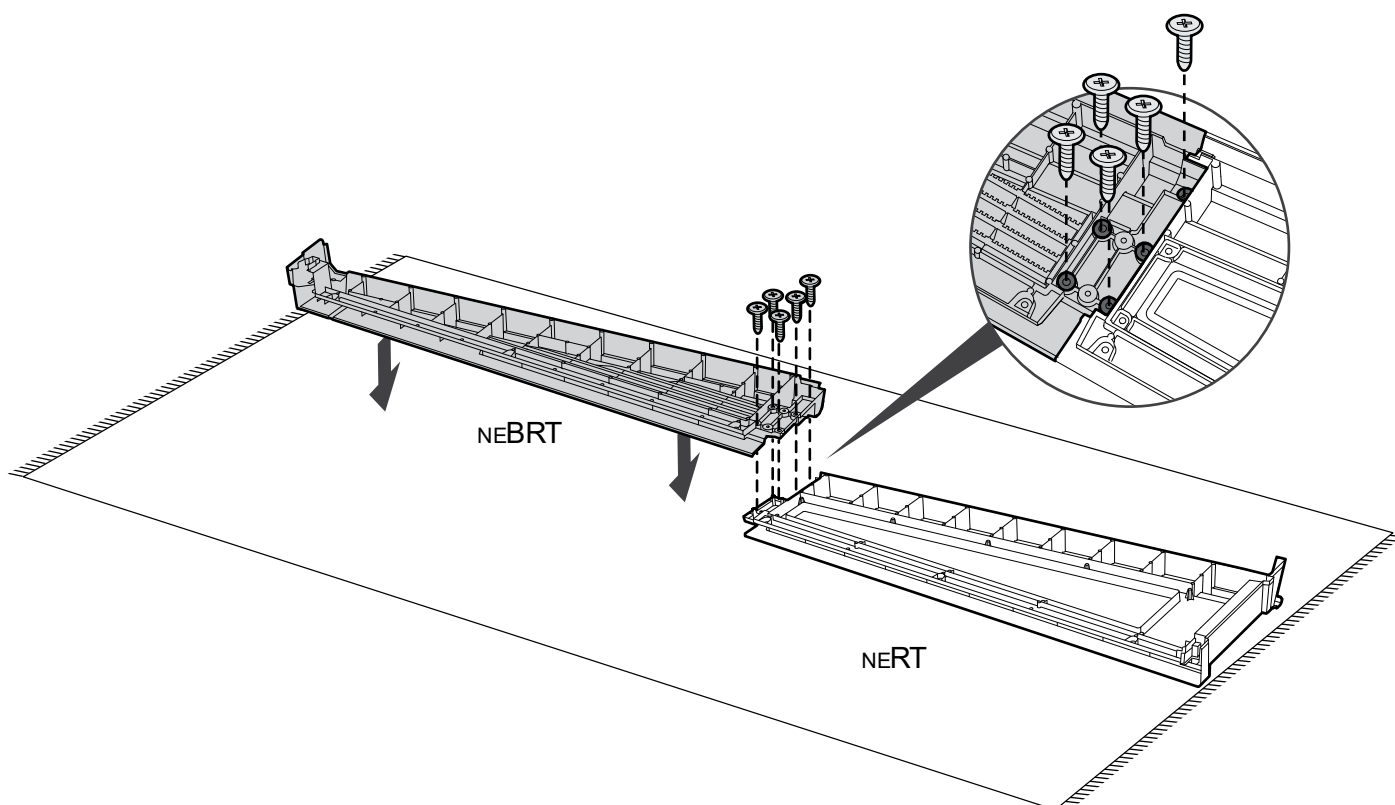

22

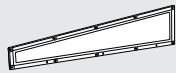

NEG T (x2)

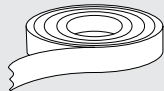

NEPL

Right  
Droit  
Derecho  
Richtig  
Rechts  
Destra  
Direito

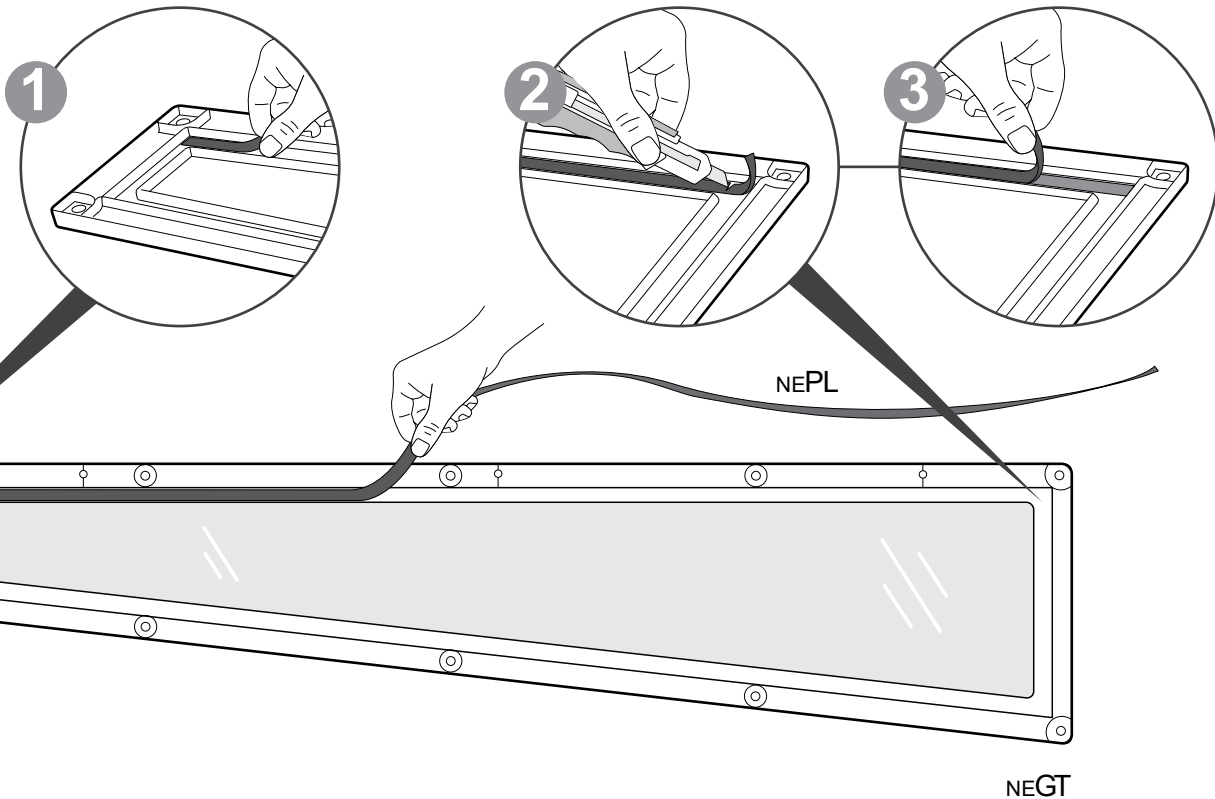

23

NEBRT + NERT

NELT + NEBLT



sc15 (x20)

Right  
Droit  
Derecho  
Richtig  
Rechts  
Destra  
Direito

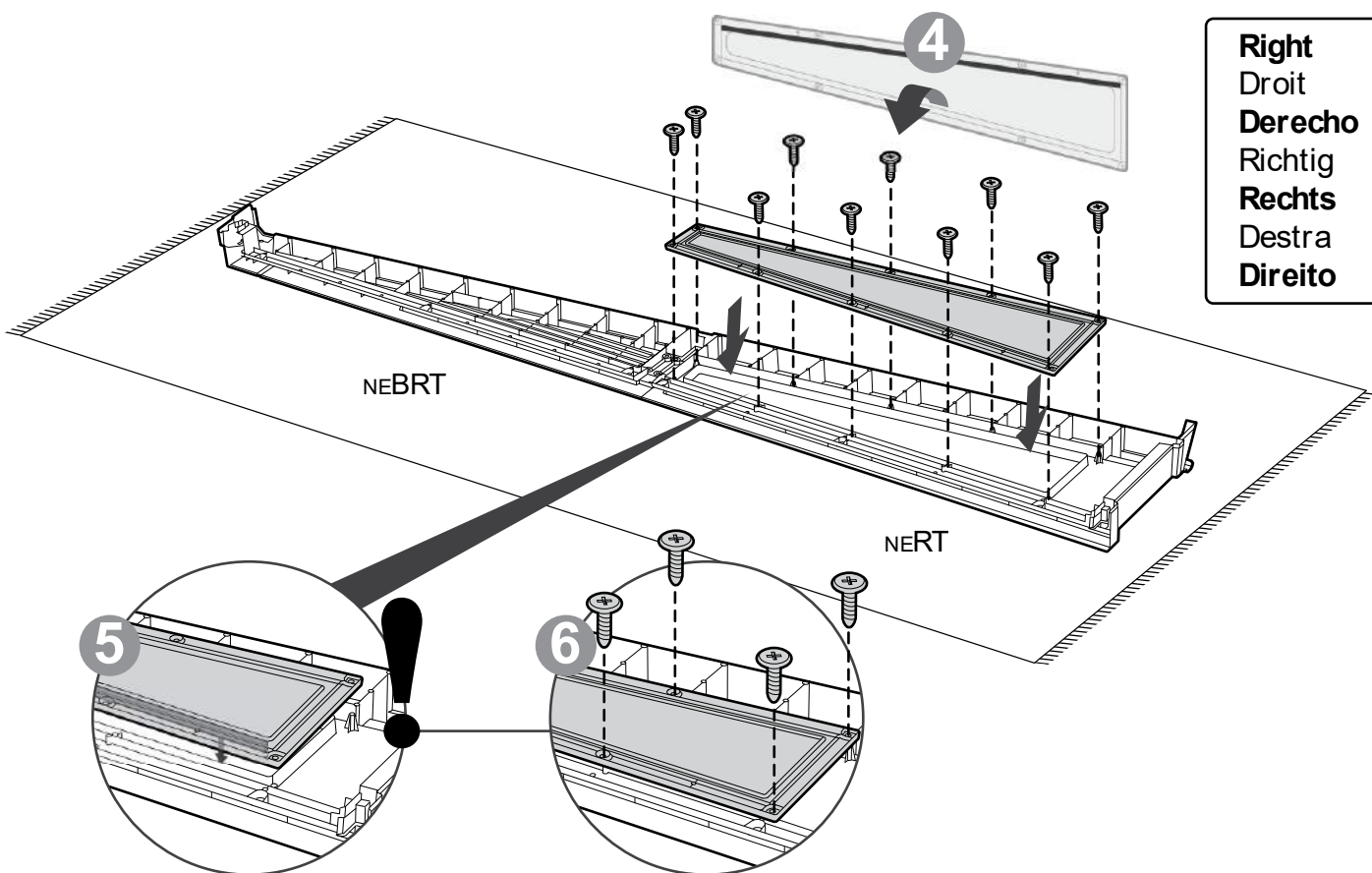

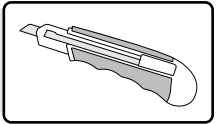



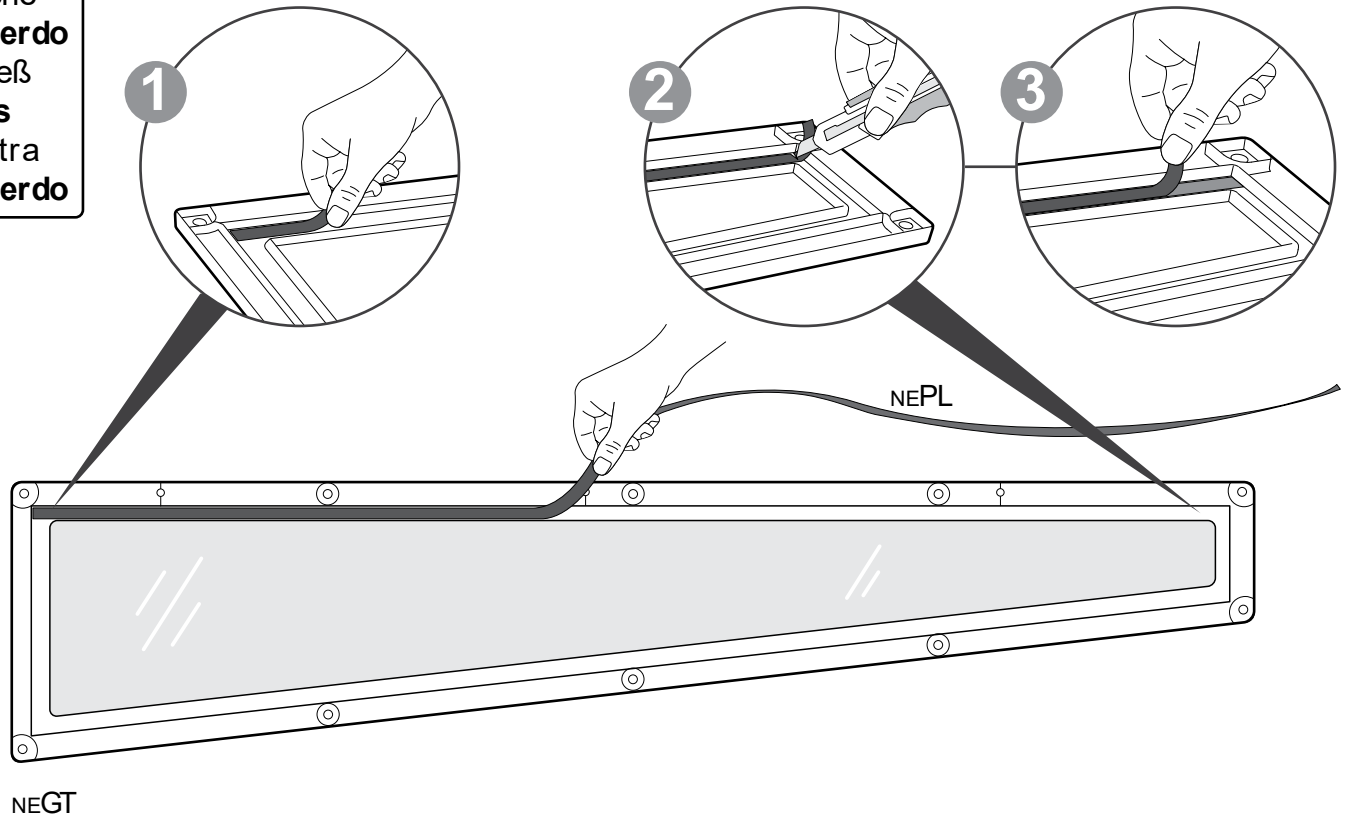

**Left**  
Gauche  
**Izquierdo**  
Verließ  
**Links**  
Sinistra  
**esquerdo**

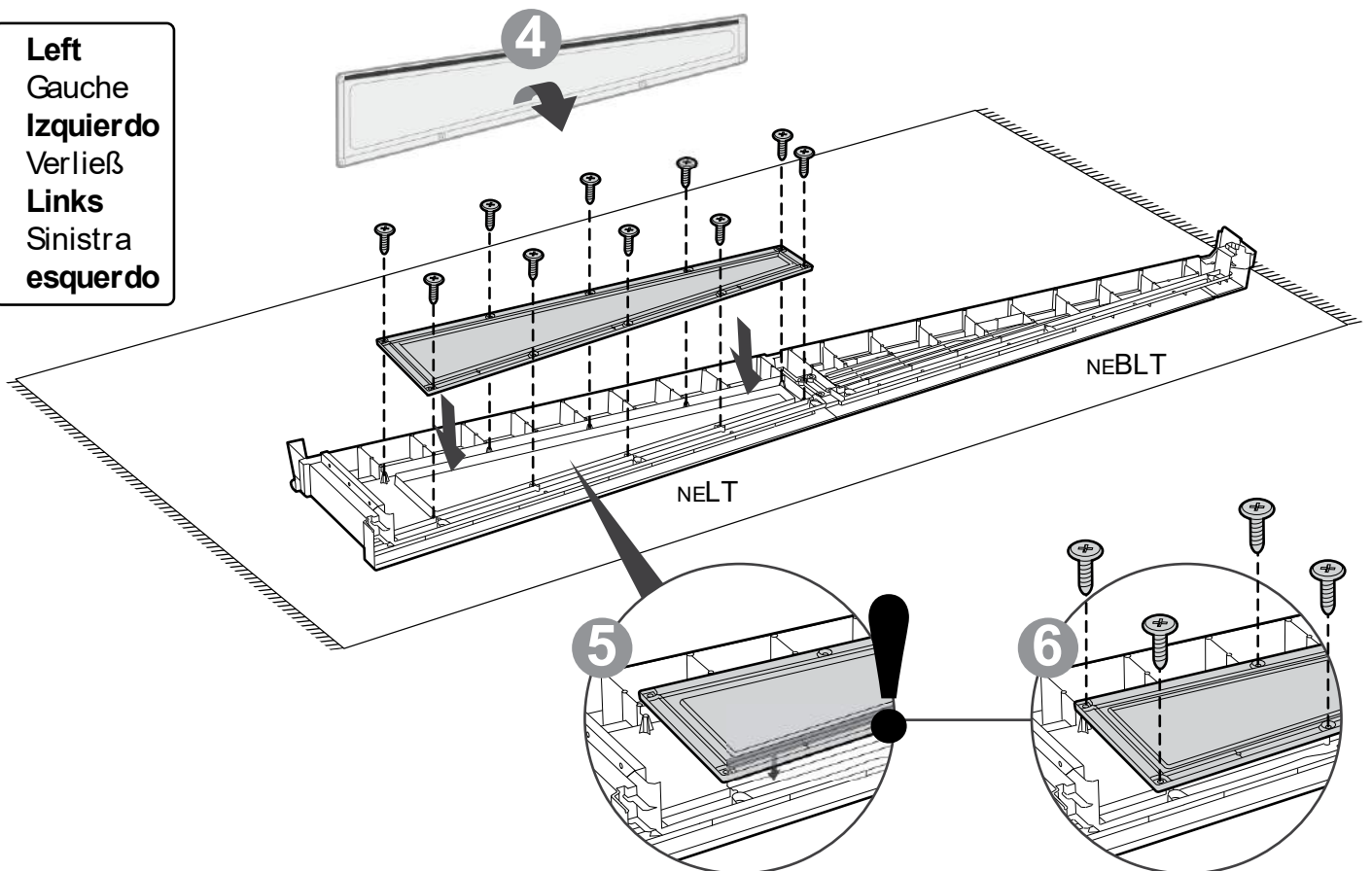

**Left**  
Gauche  
**Izquierdo**  
Verließ  
**Links**  
Sinistra  
**esquerdo**

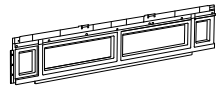

24

-  NEFFM (x1)
-  NEFF (x1)
-  sc15 (x2)

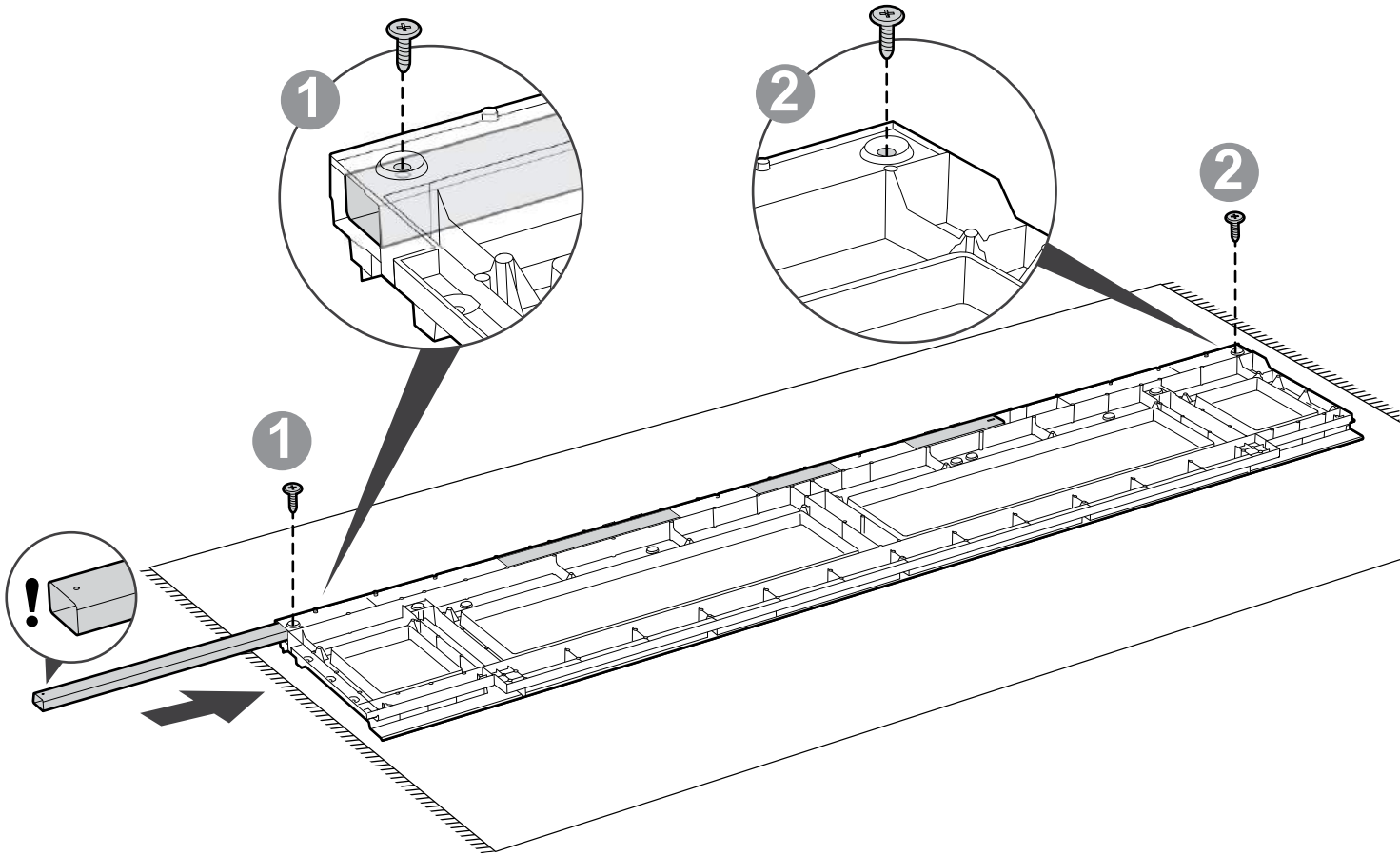

25

-  NETDP (x1)
-  sc15 (x3)

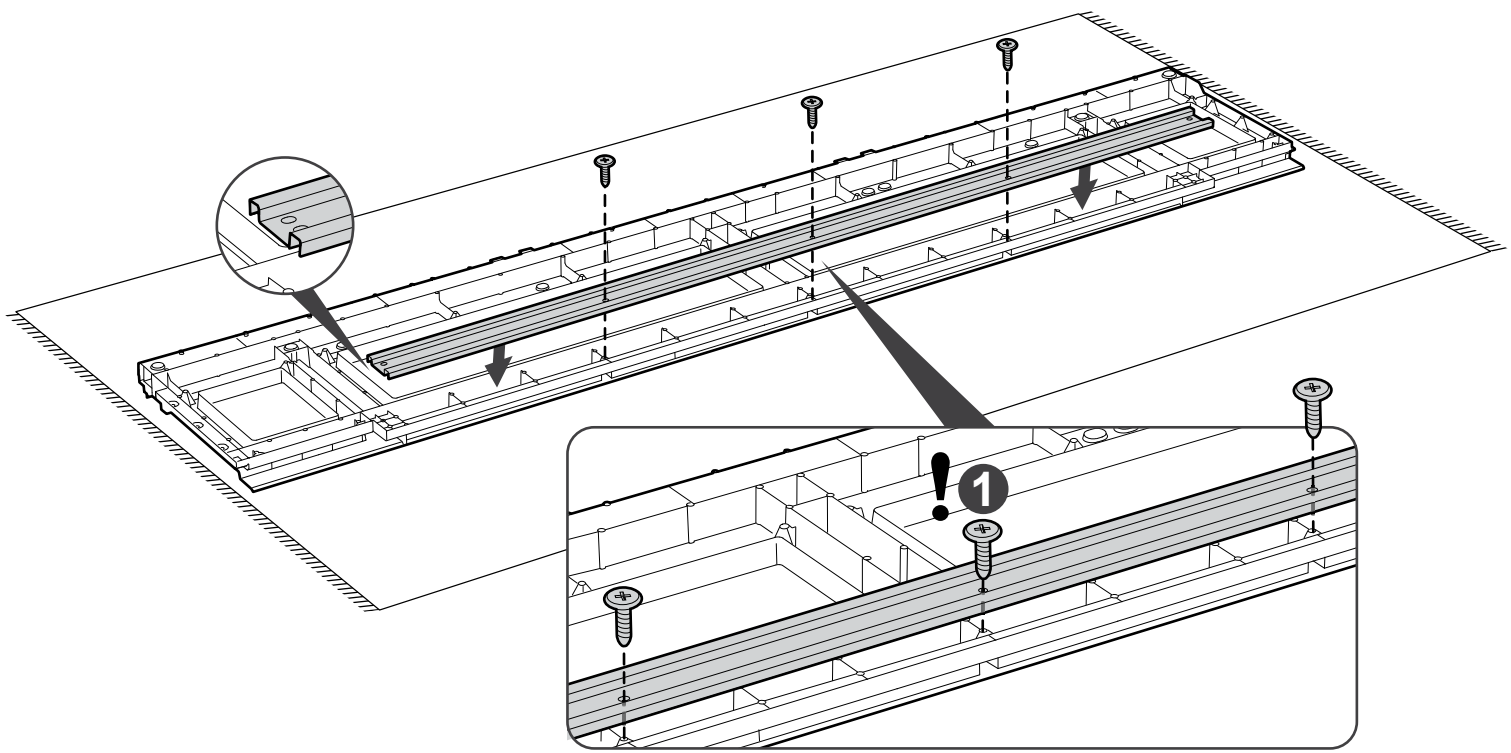

26

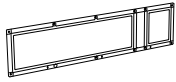

NEGR (x2)



NEPL



sc15 (x24)

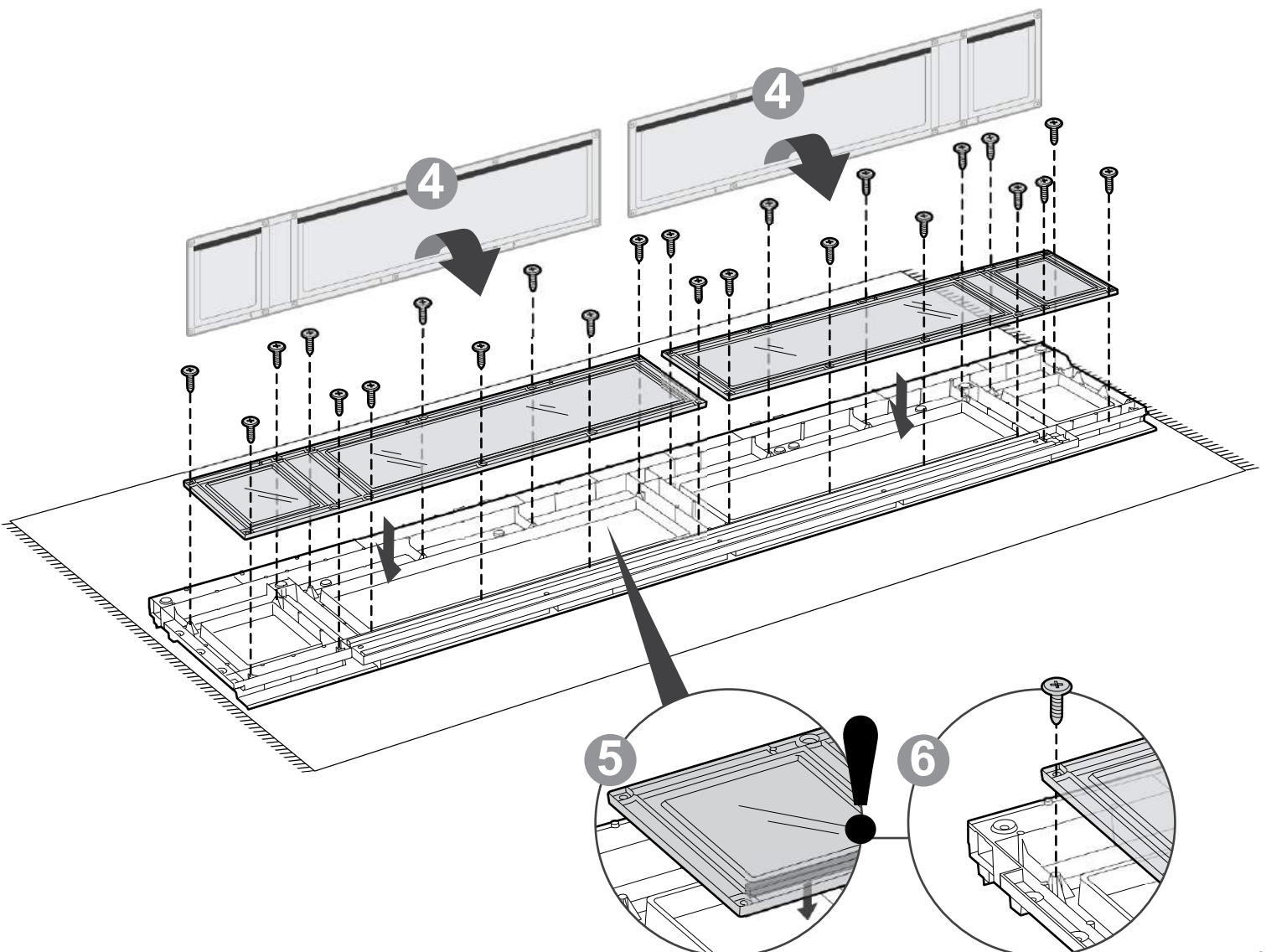
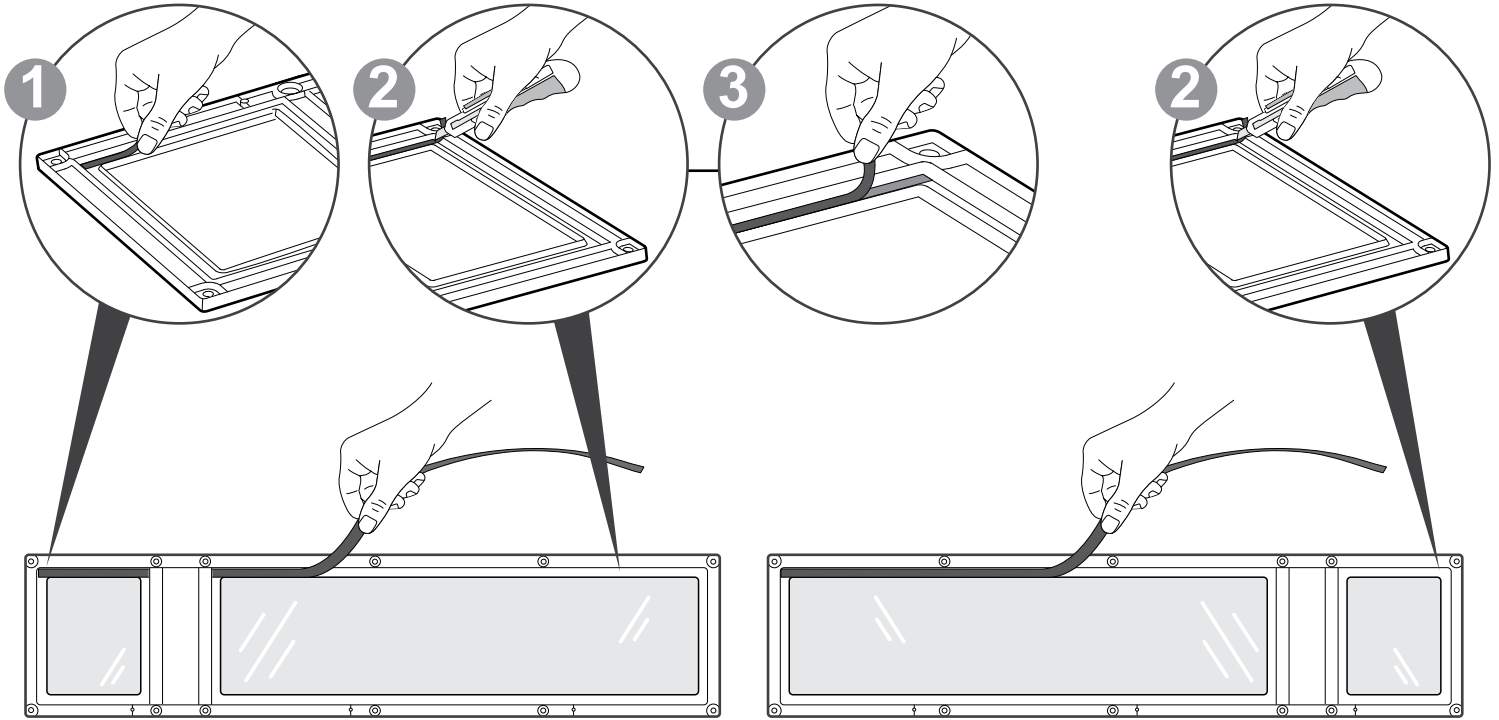
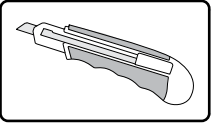

27

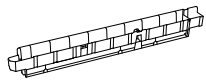

NELD (x1)

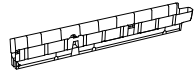

NERD (x1)

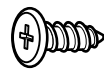

sc15 (x2)

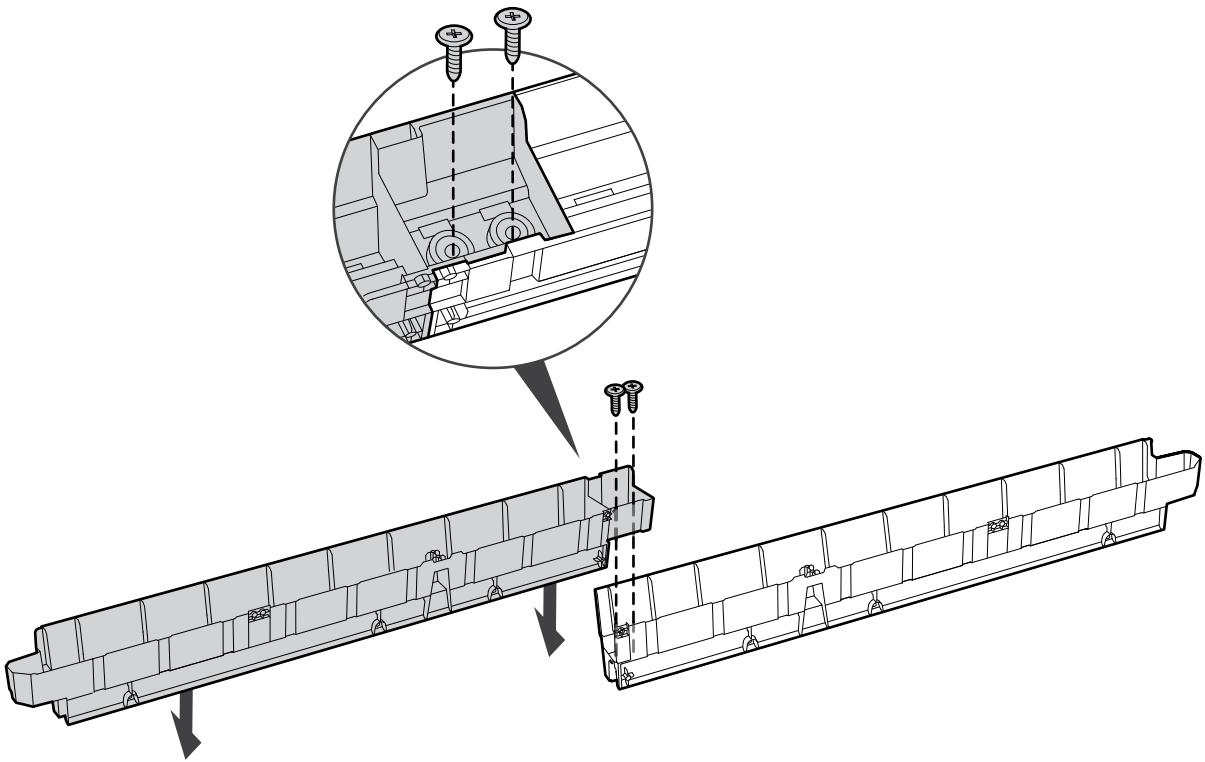

28

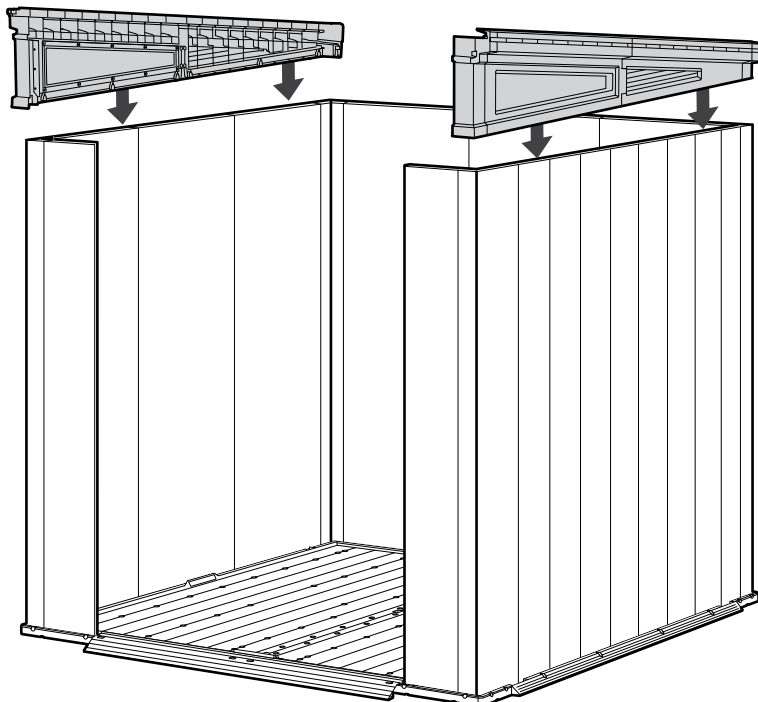
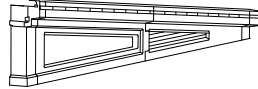
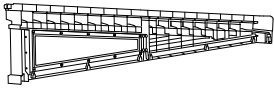

29

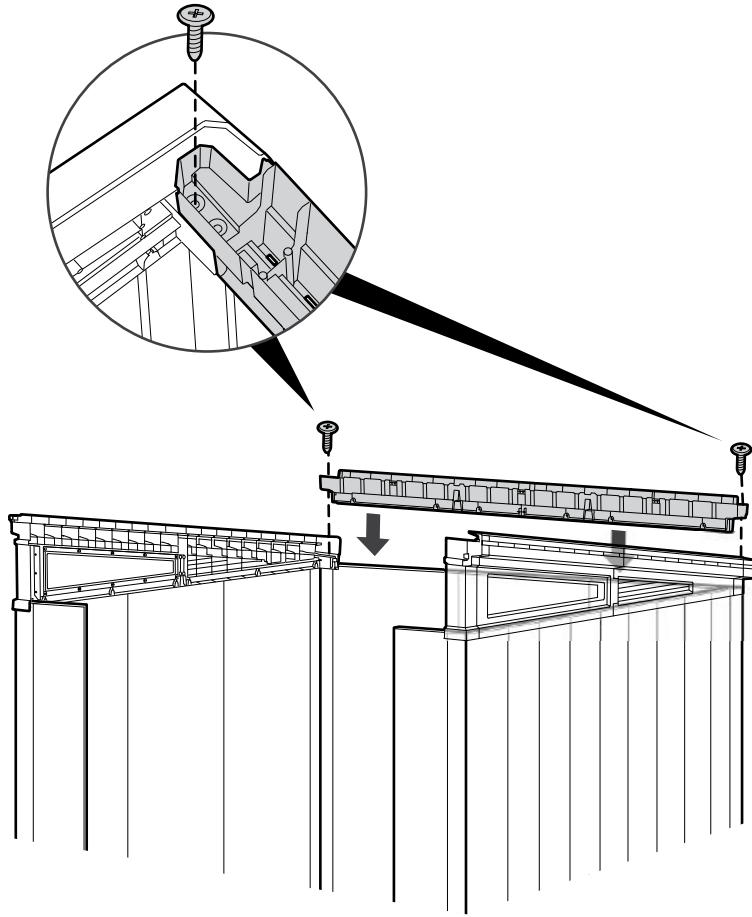
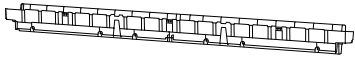

30

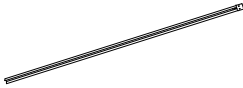

neBPM (x1)



sc15 (x2)

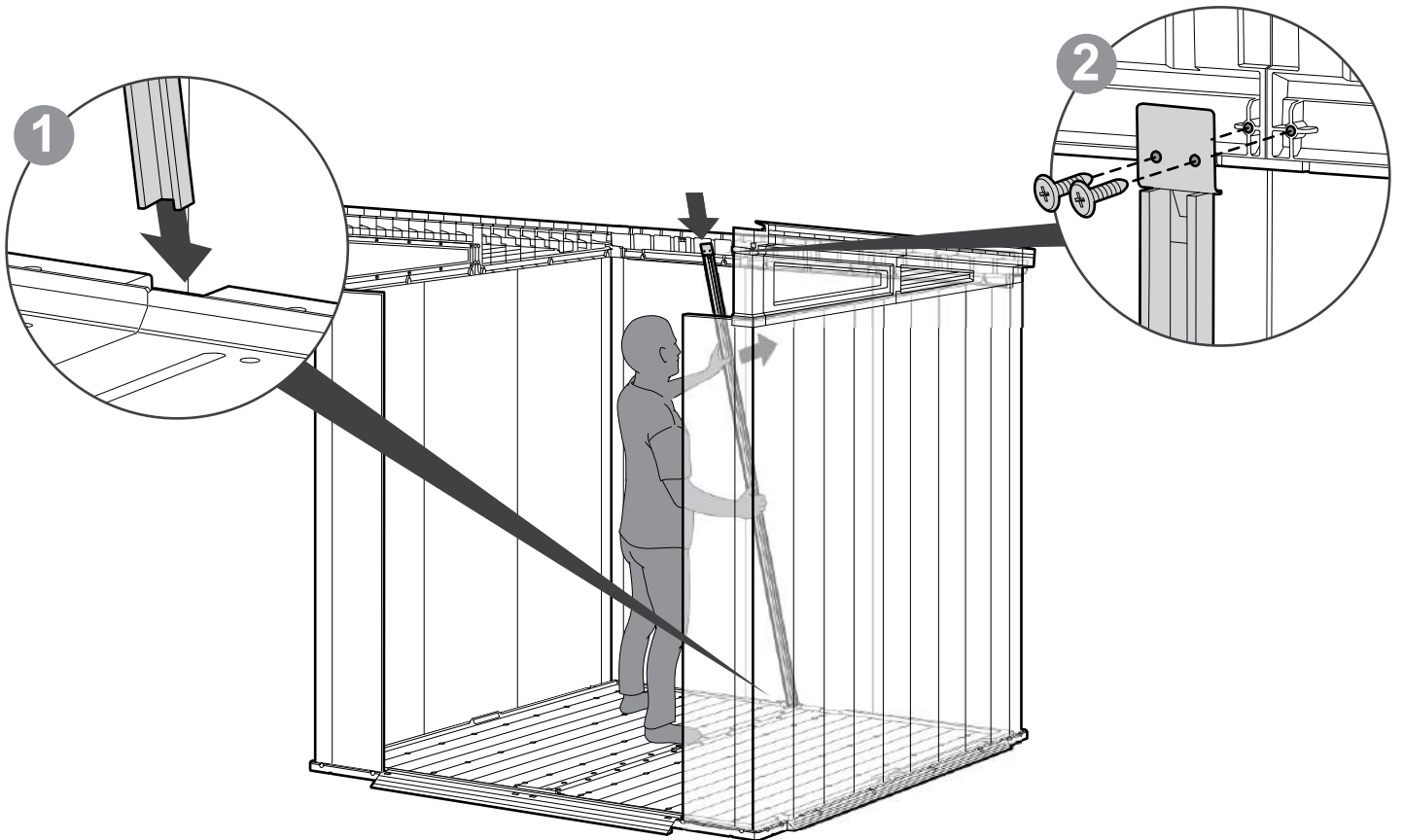

31



NESPM (x1)



sc15 (x2)

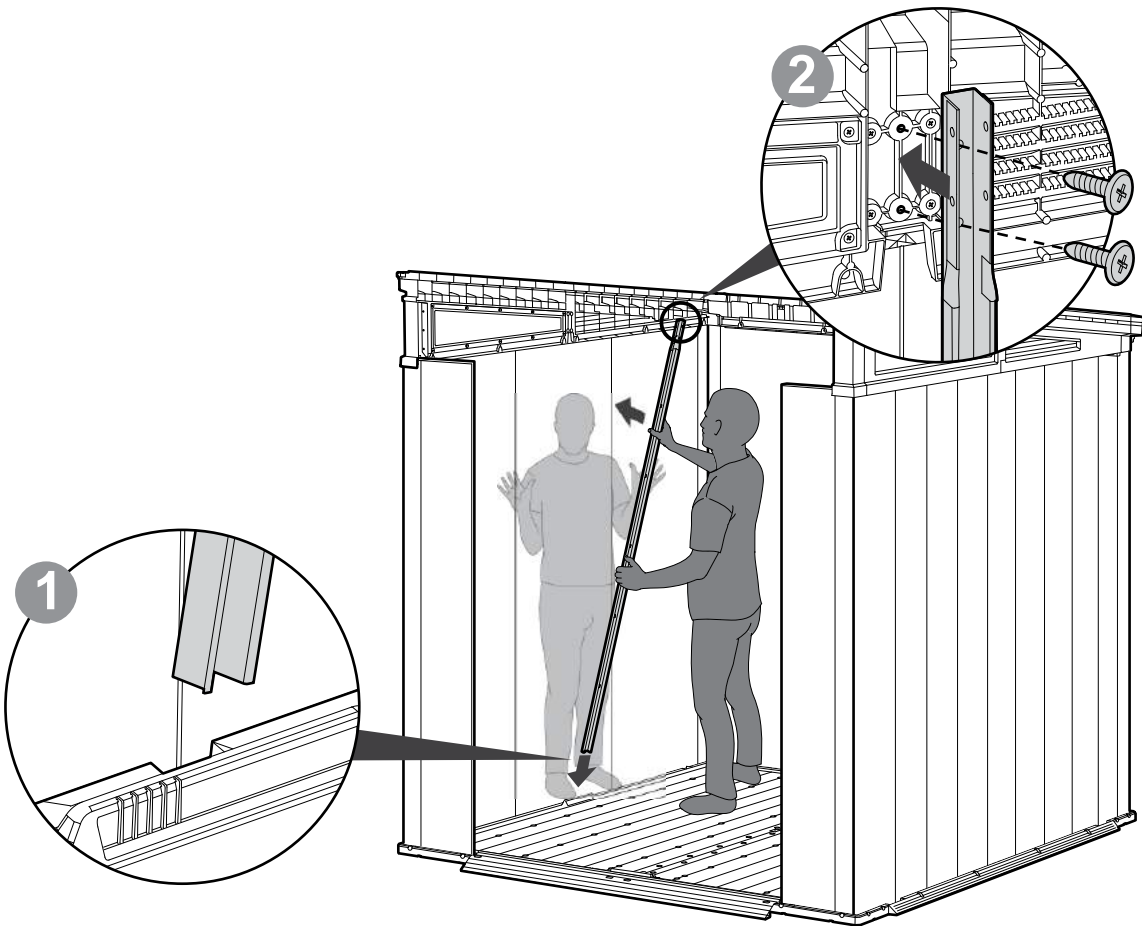

32



NESPM (x1)



sc15 (x2)

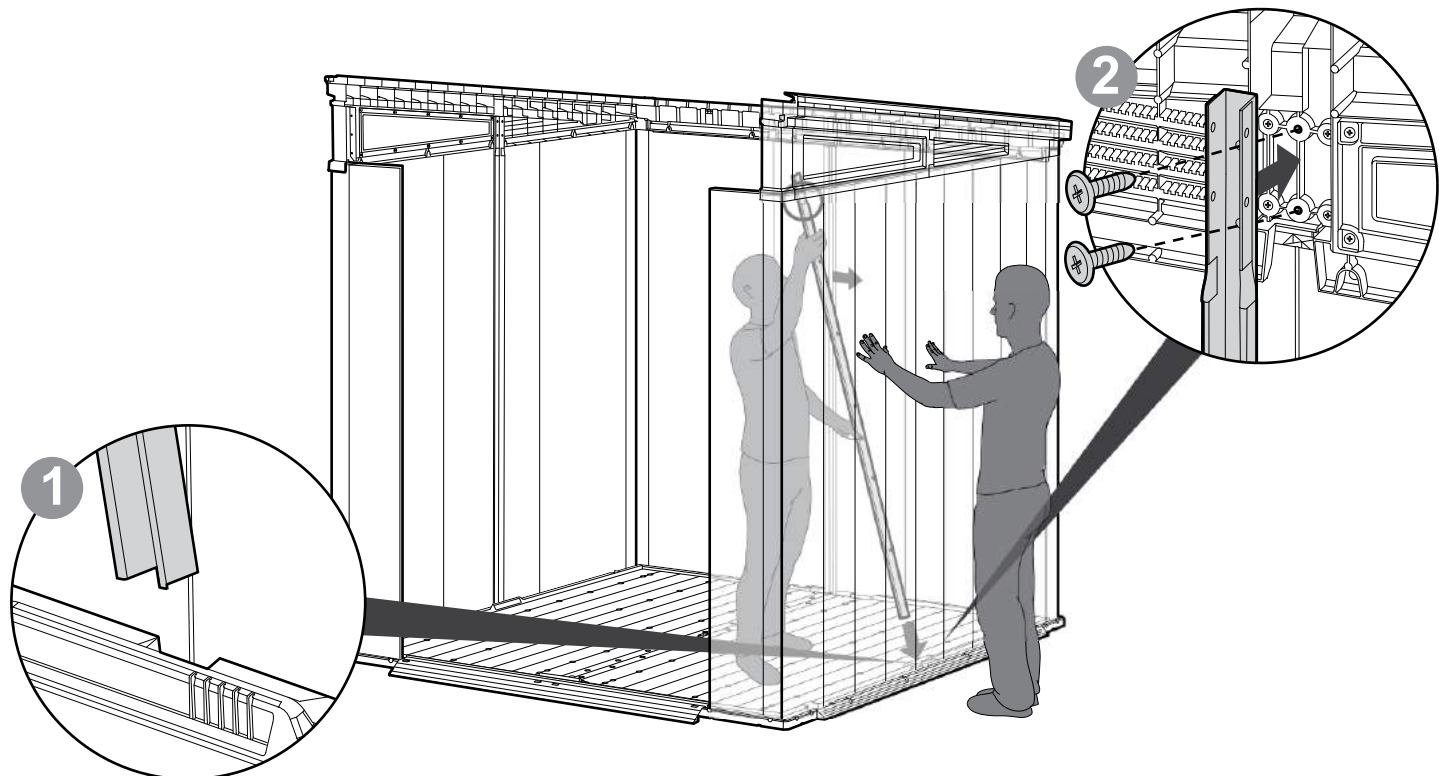



33



NESPC (x2)



sc8 (x4)

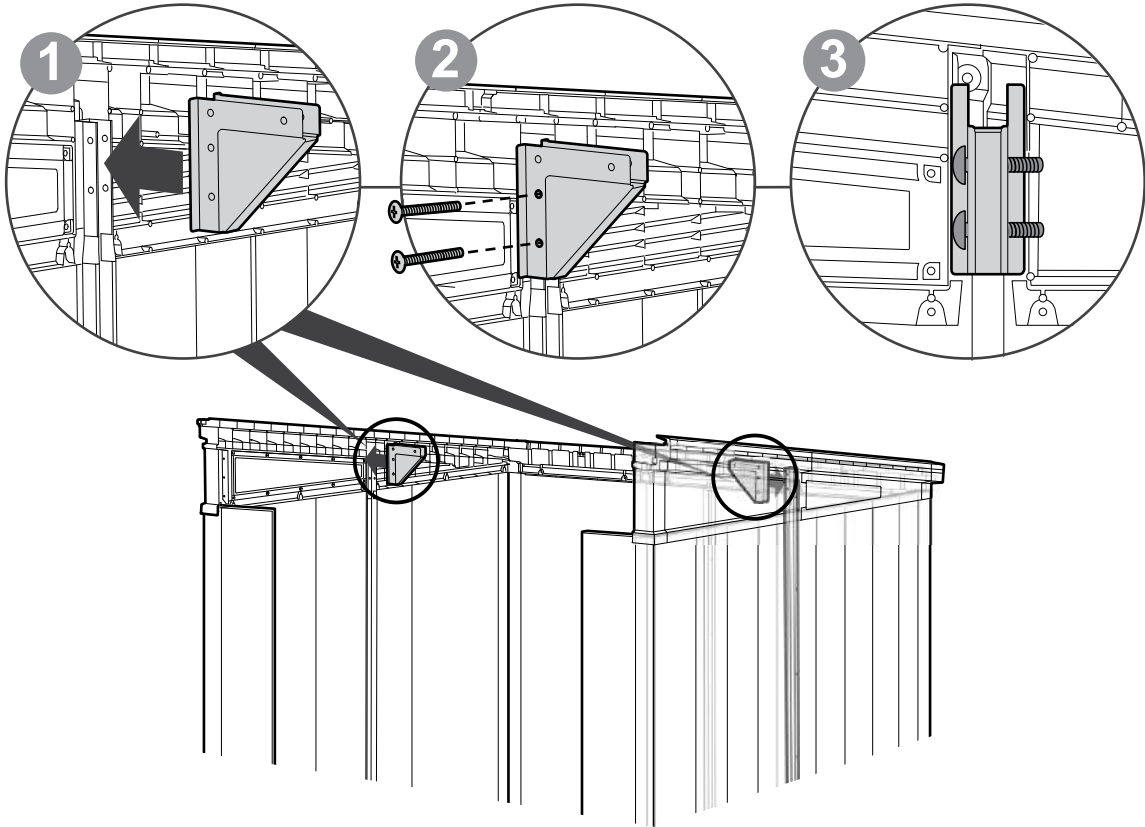

34



NERB7 (x1)



sc8 (x4)



scn8 (x8)

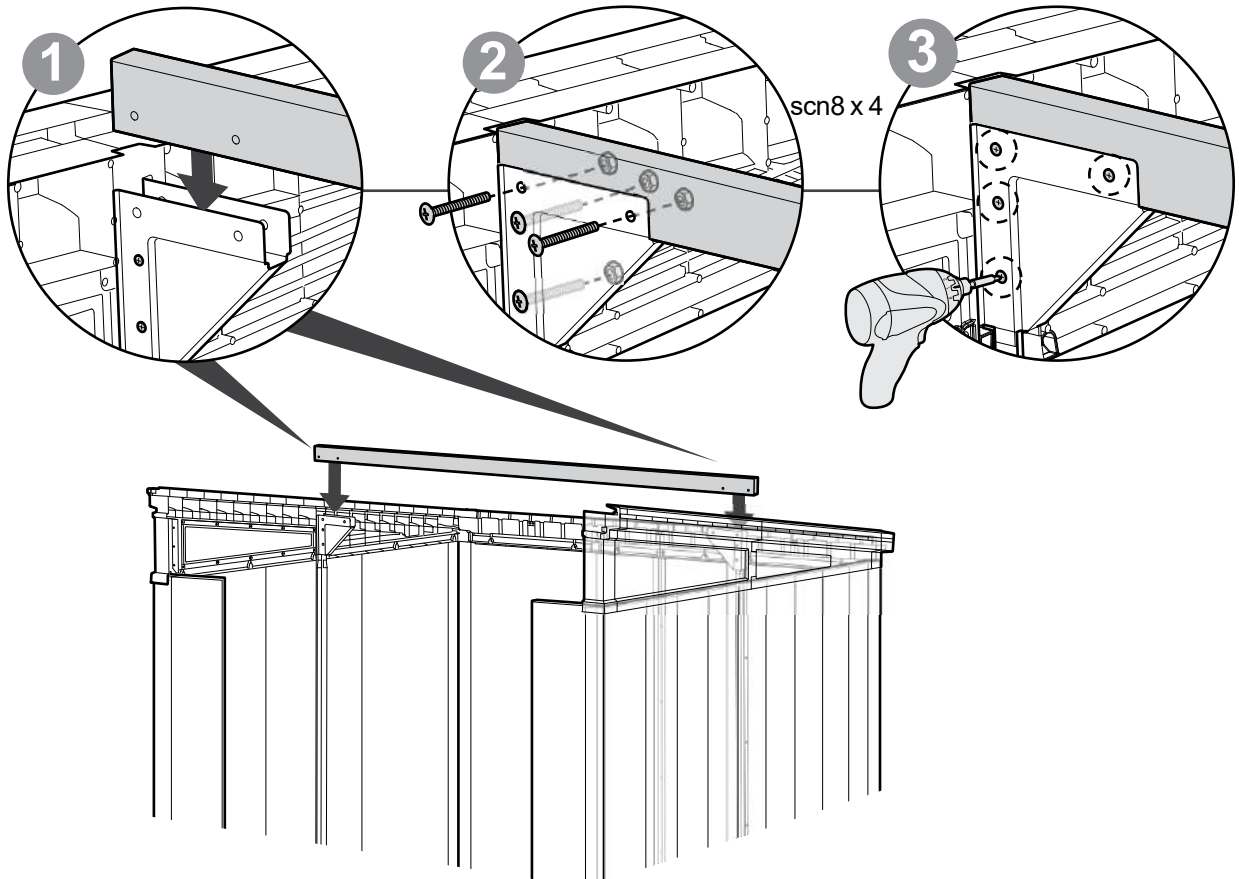

35



NE LDP (x1)



NE RDP (x1)

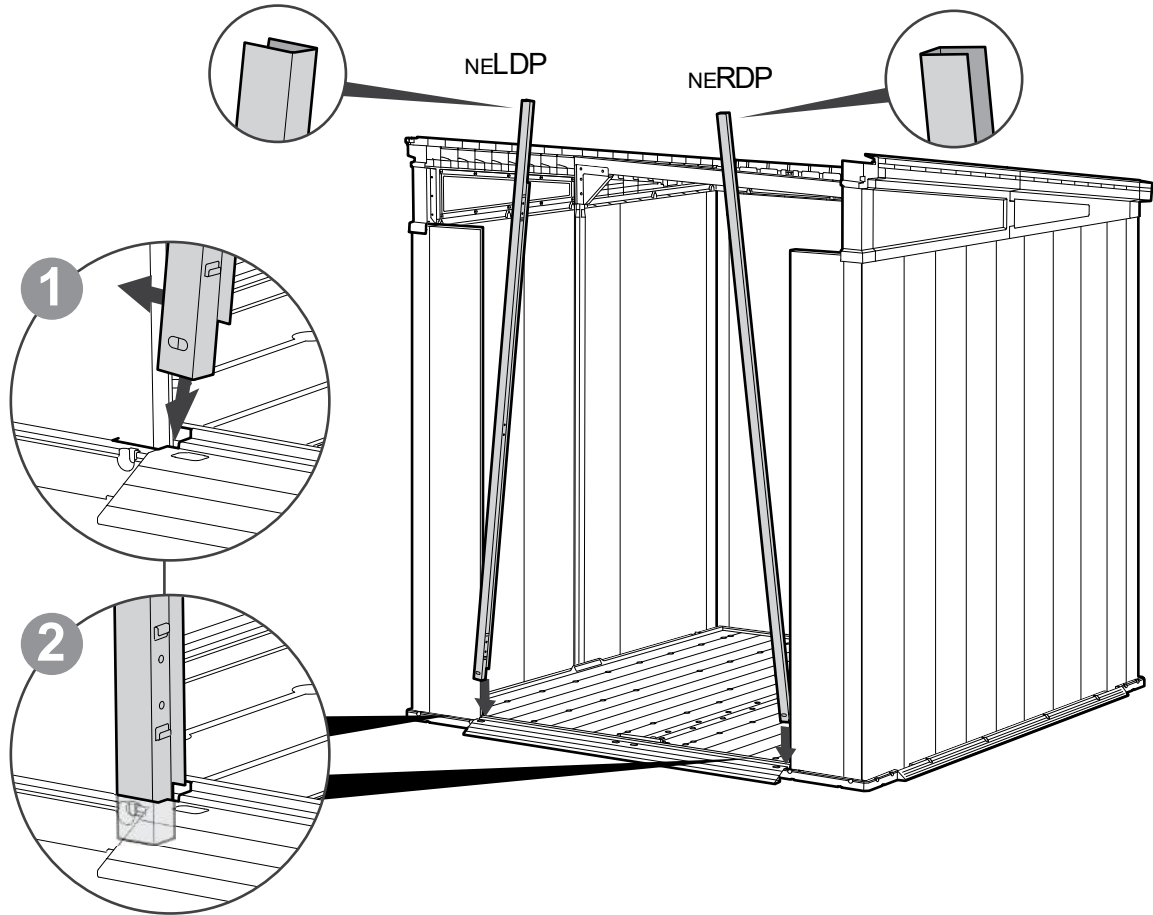

36

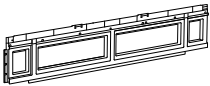

NE FF (x1)

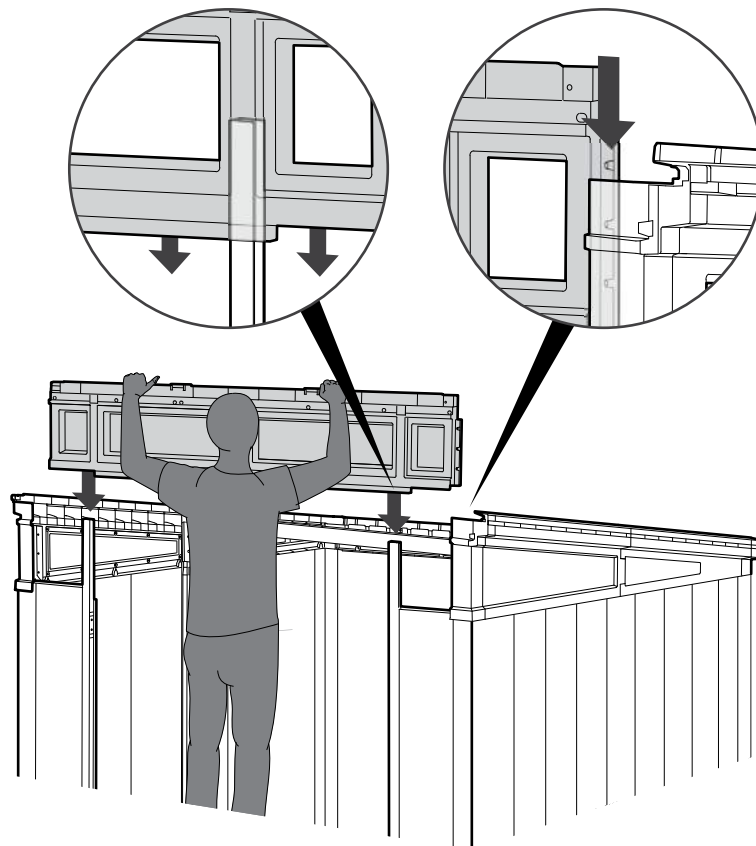

37

sc15 (x8)

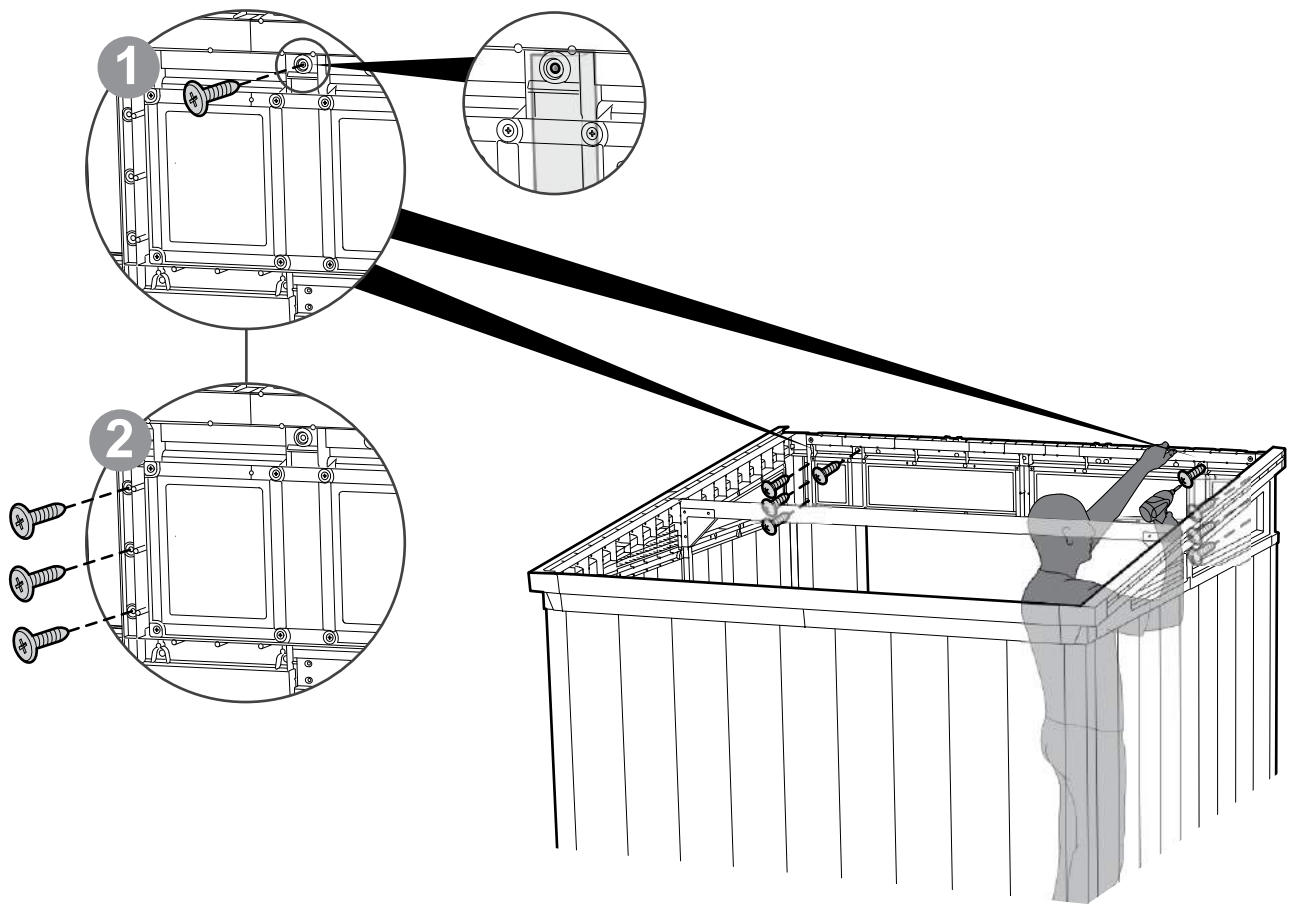

38

NERA (x2)

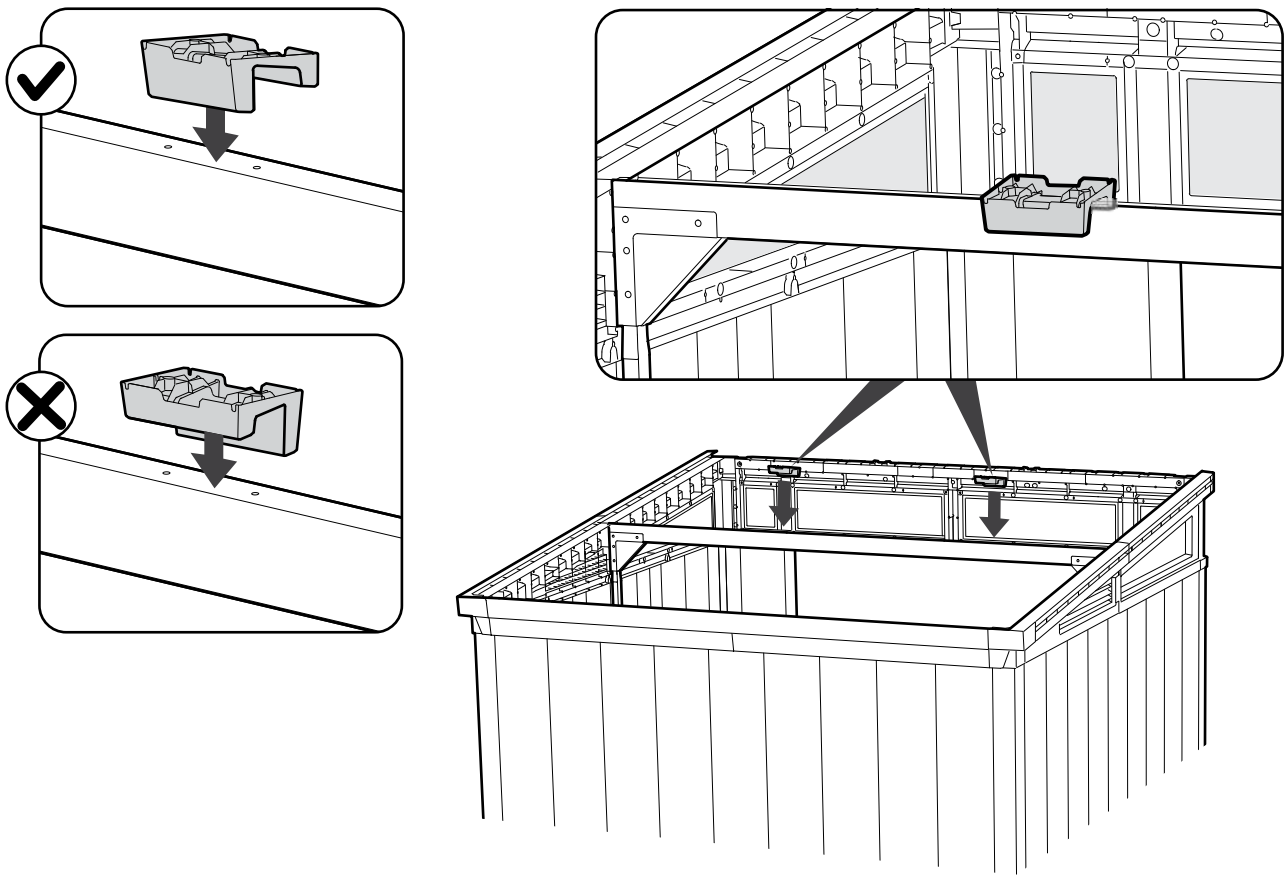

39



NERM (x2)



sc15 (x12)

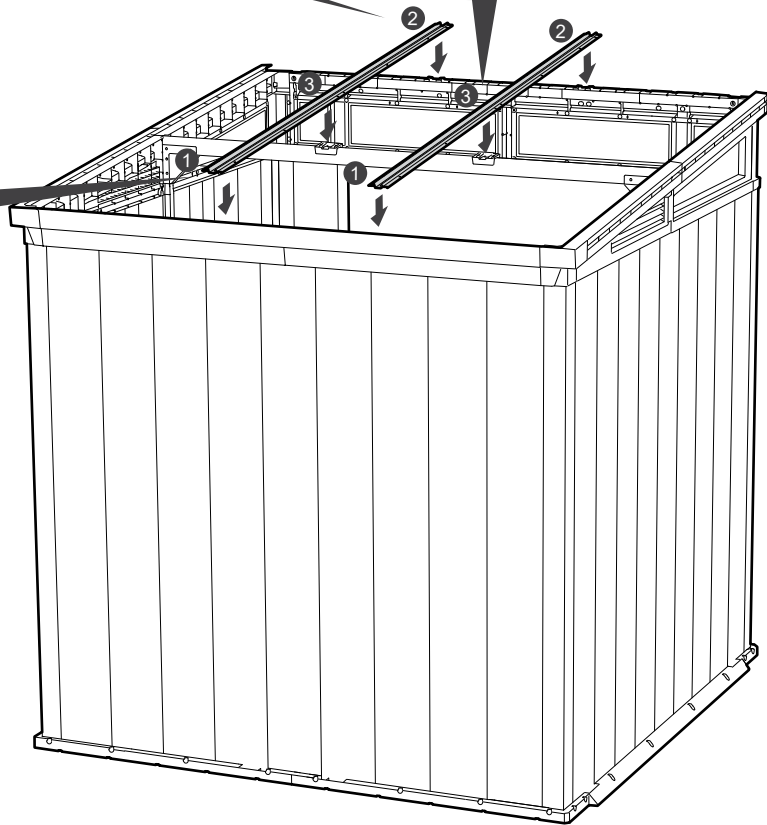
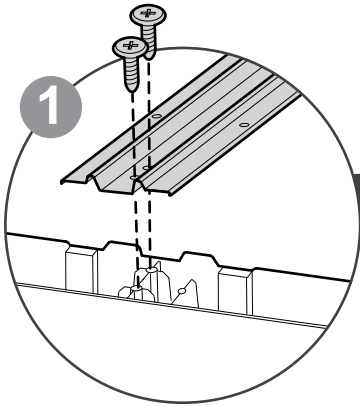
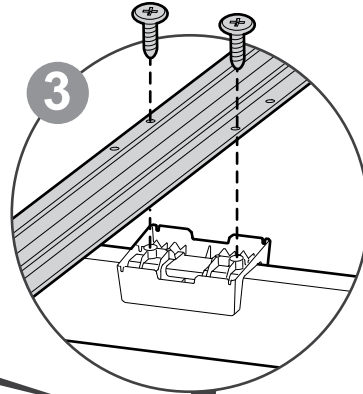
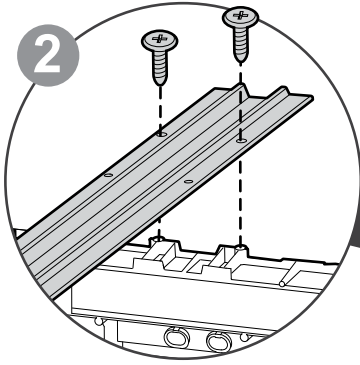

40

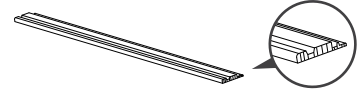

NEPRE (x2)

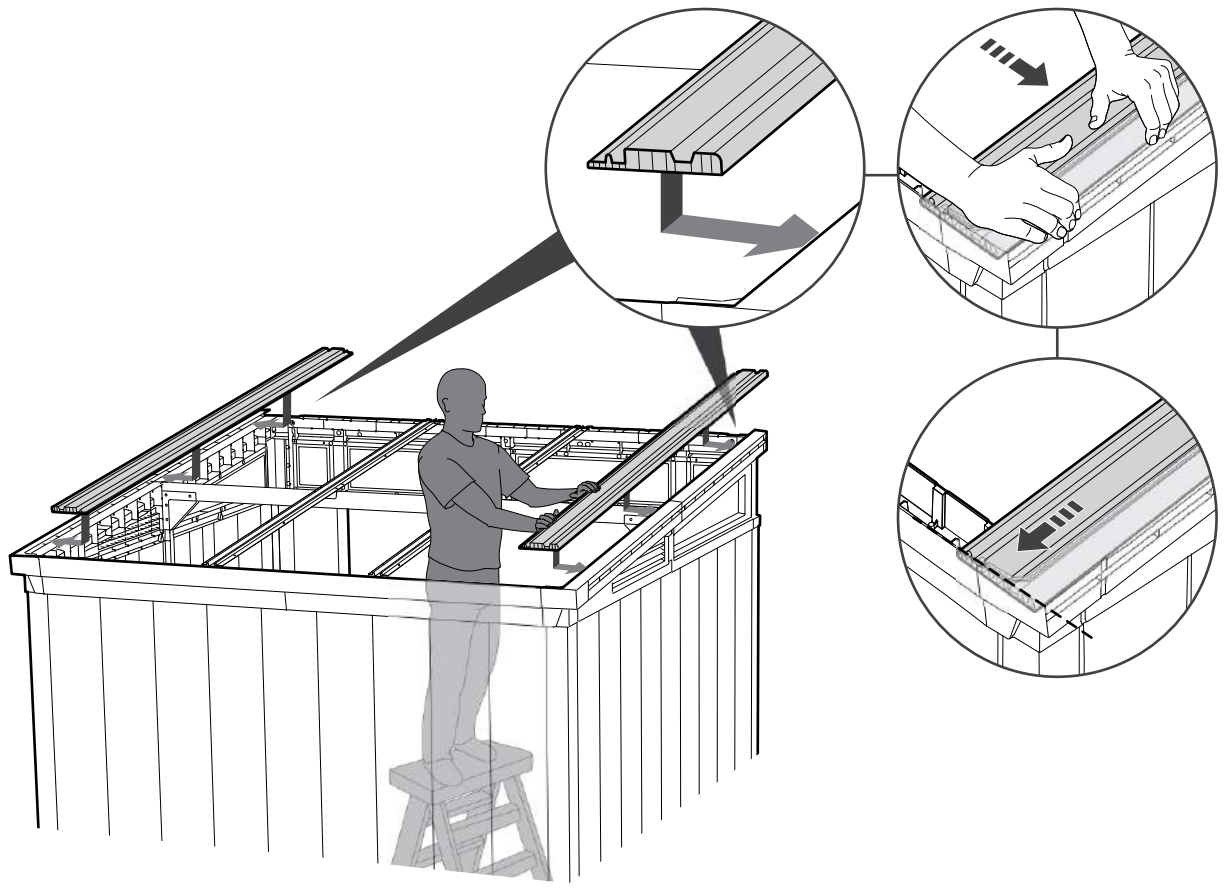

41

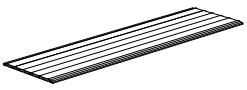

NEPR (x3)

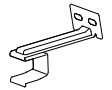

NERK (x3)

x3

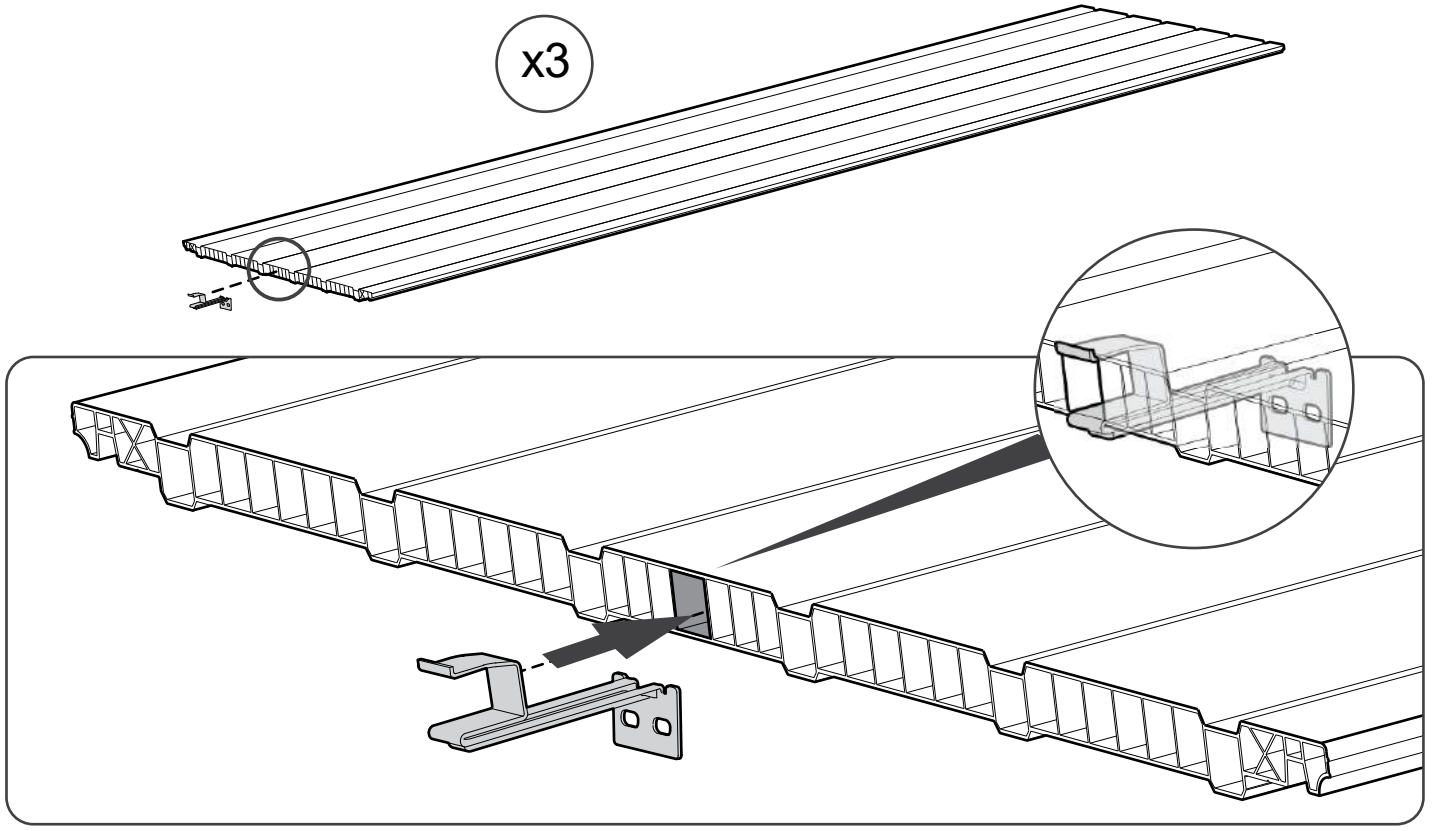

42



NEPR (x3)

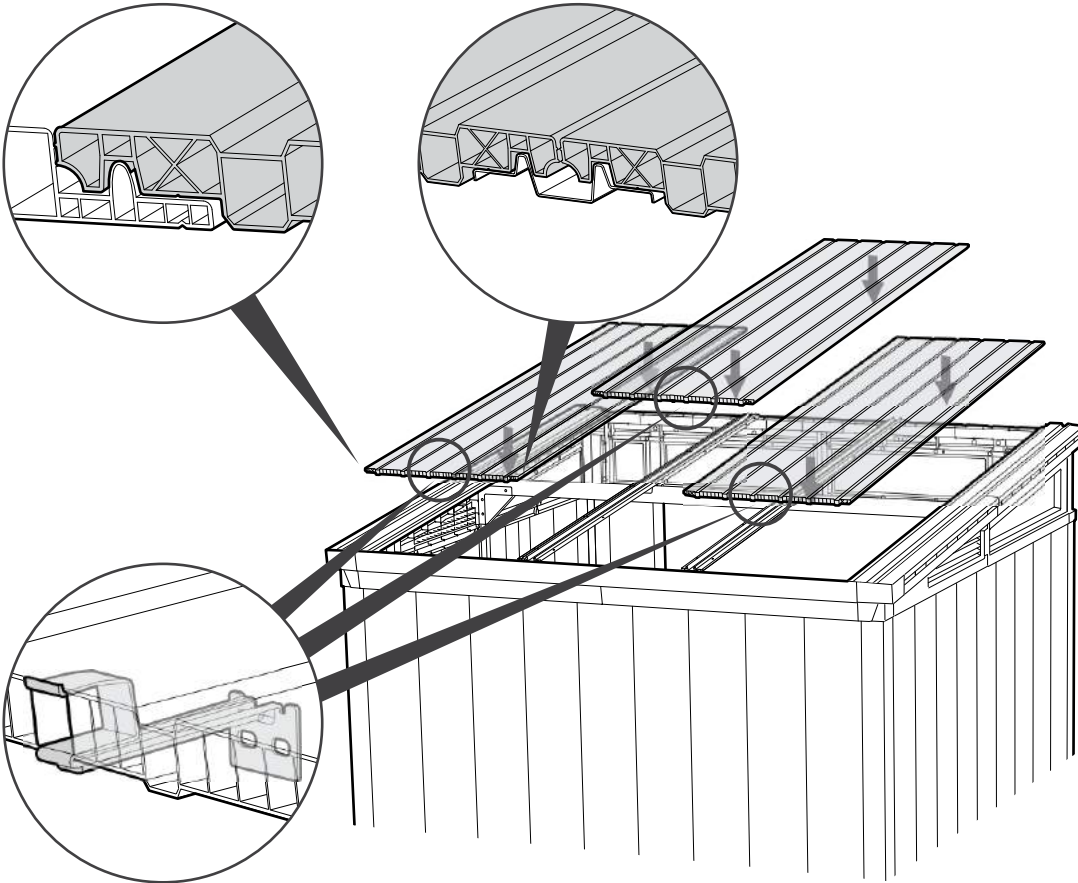

43



sc15 (x6)

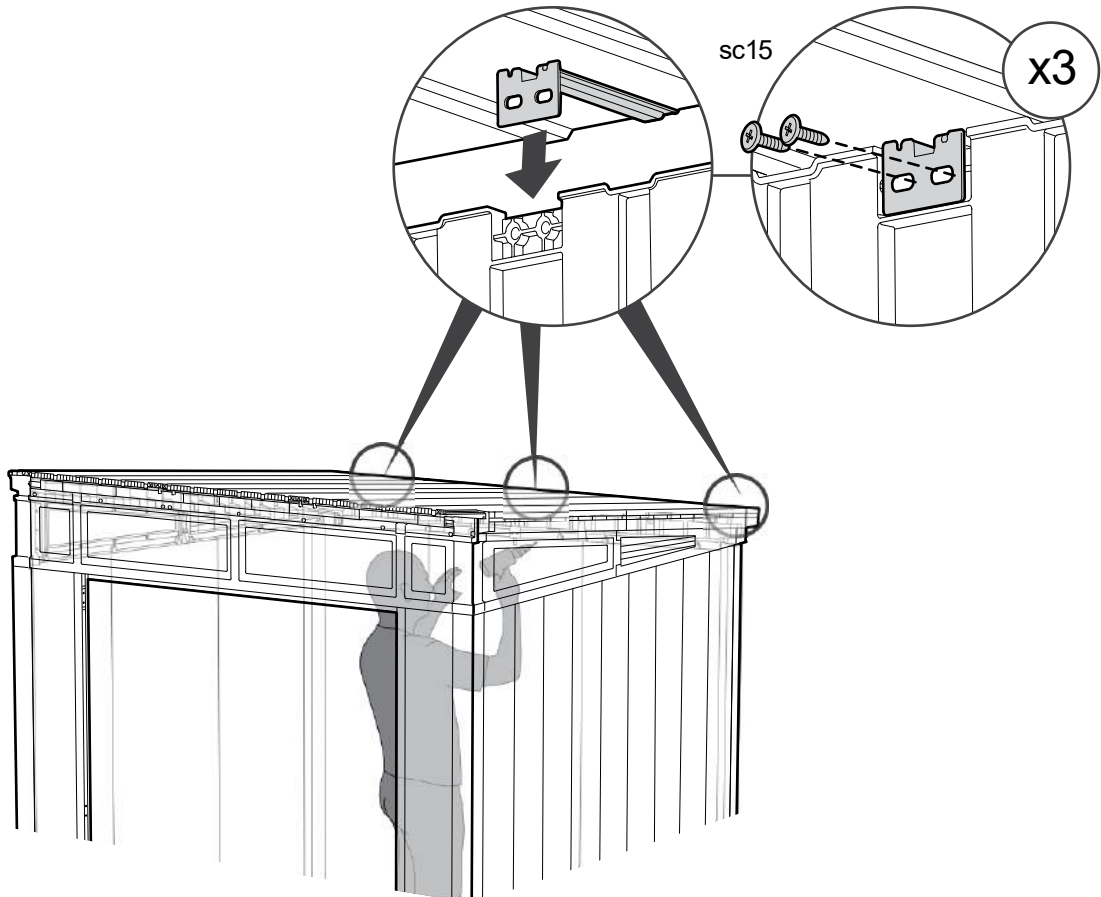

44



NELC (x1)



NERC (x1)

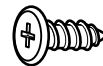

sc15 (x2)

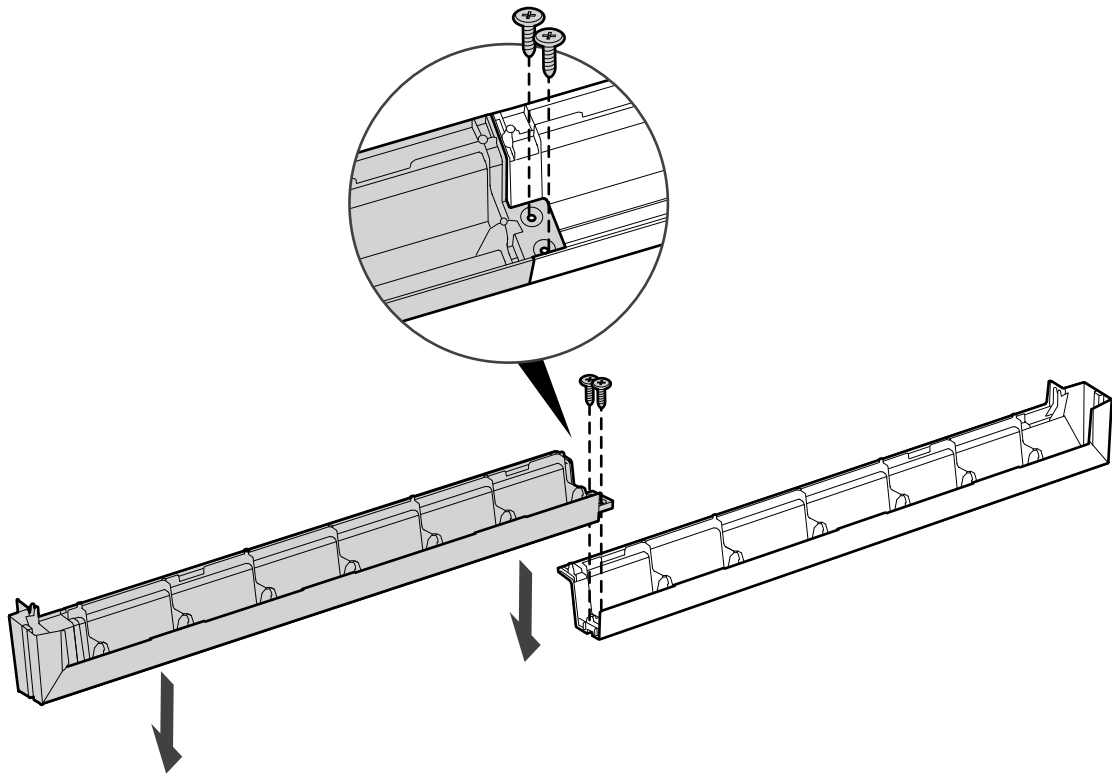

45

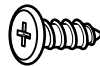

sc15 (x9)

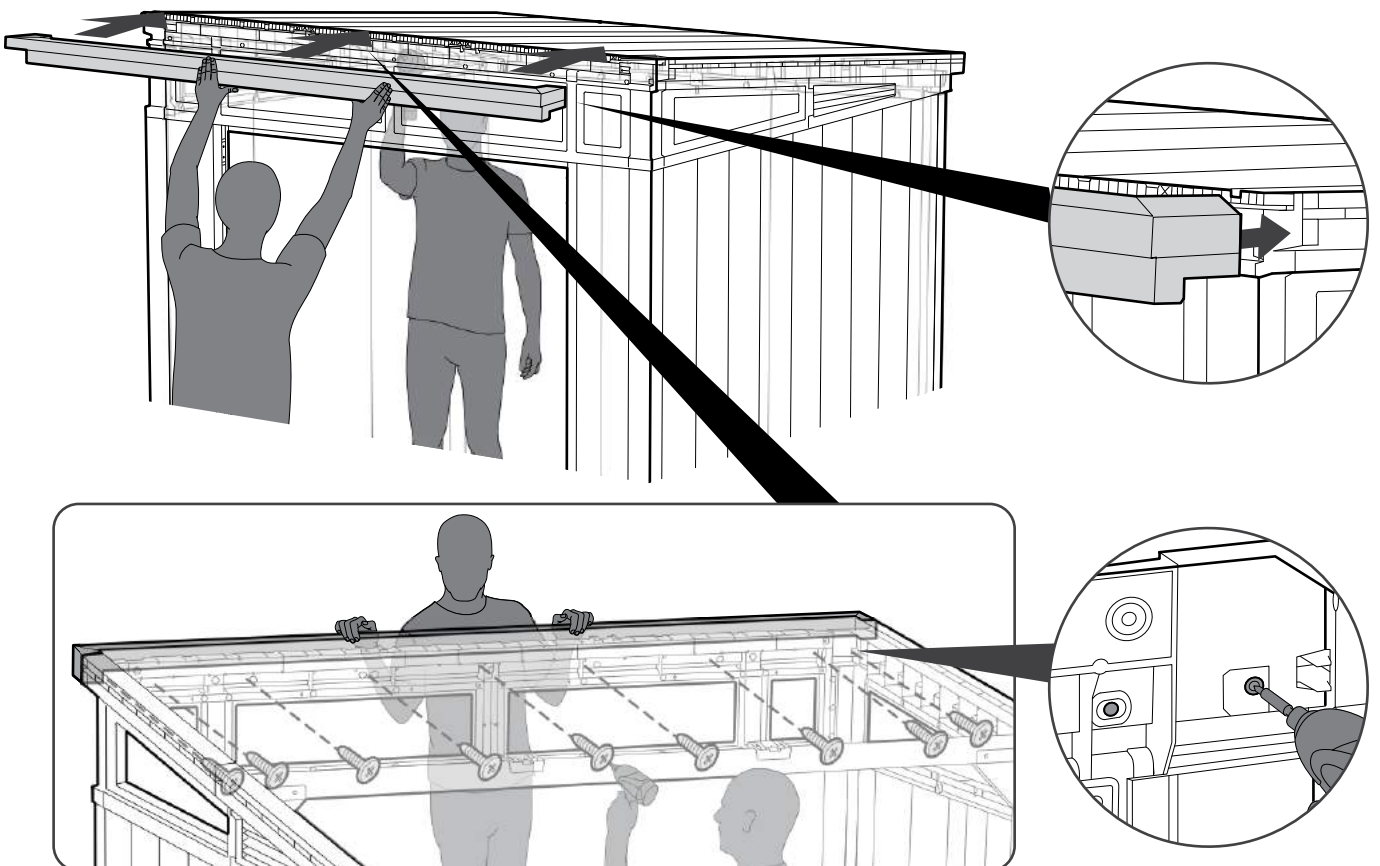

46



scw1 (x20)

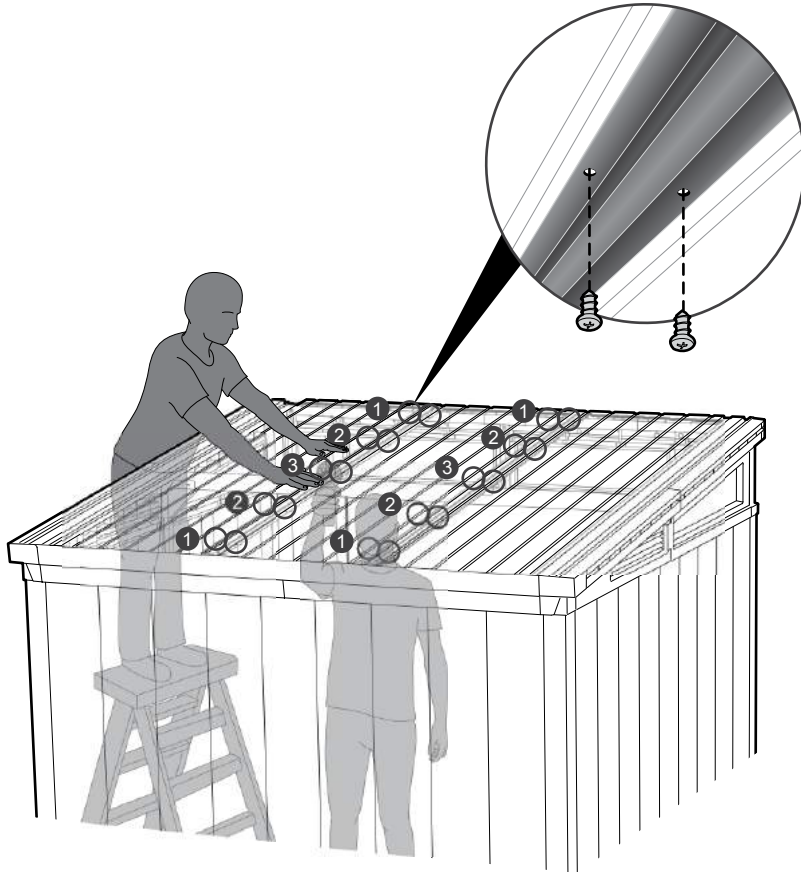

47



scw1 (x8)

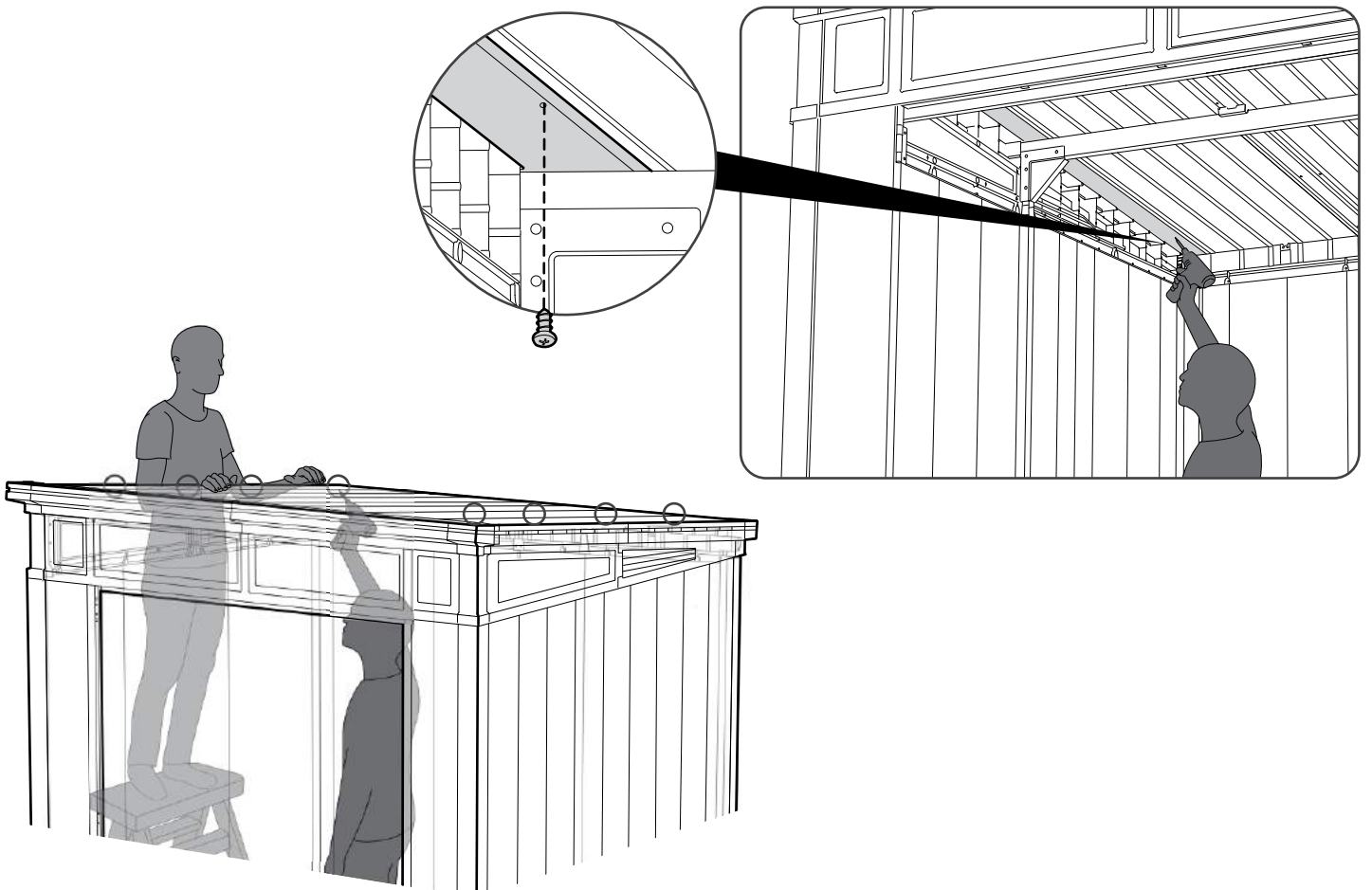



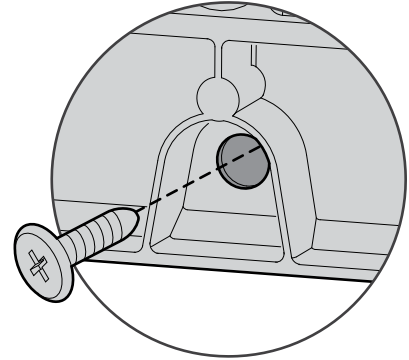
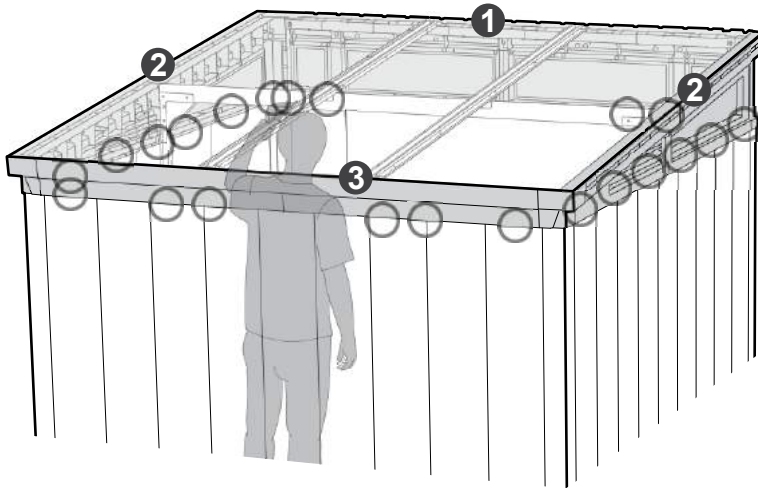

**Front | Avant | Delante | Vorderseite | Voorkant | Anteriore | Frente**

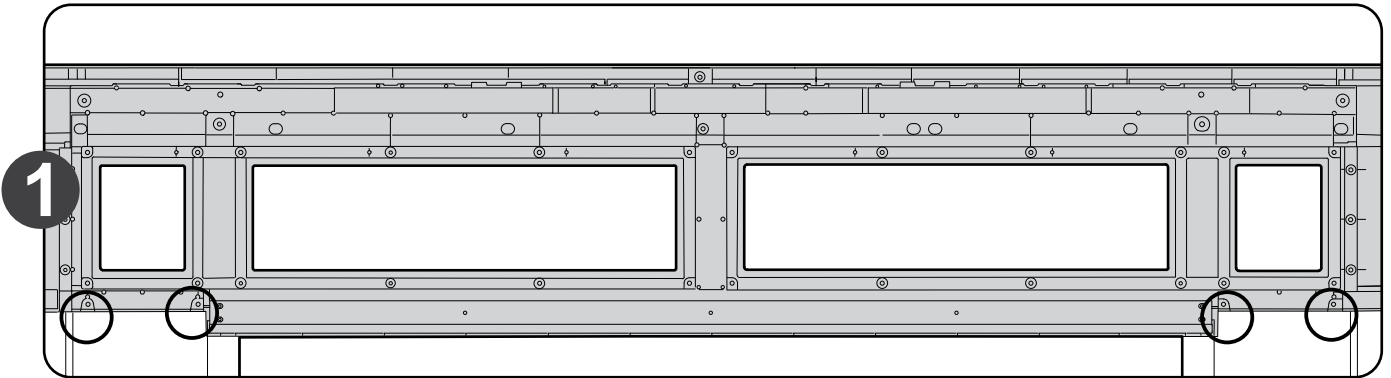

**Right | Droit | Derecho | Richtig | Rechts | Destra | Direito**  
**Left | Gauche | Izquierdo | Verließ | Links | Sinistra | izquierdo**

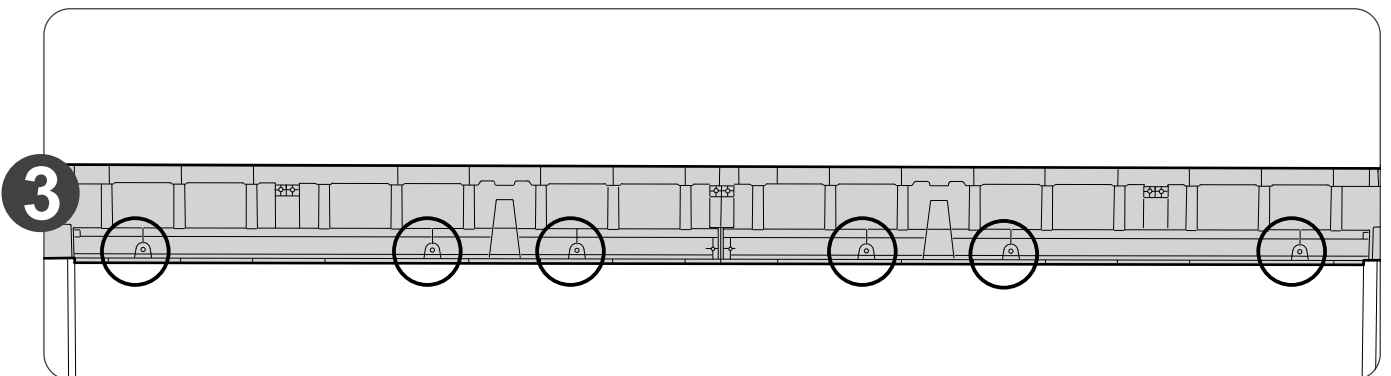
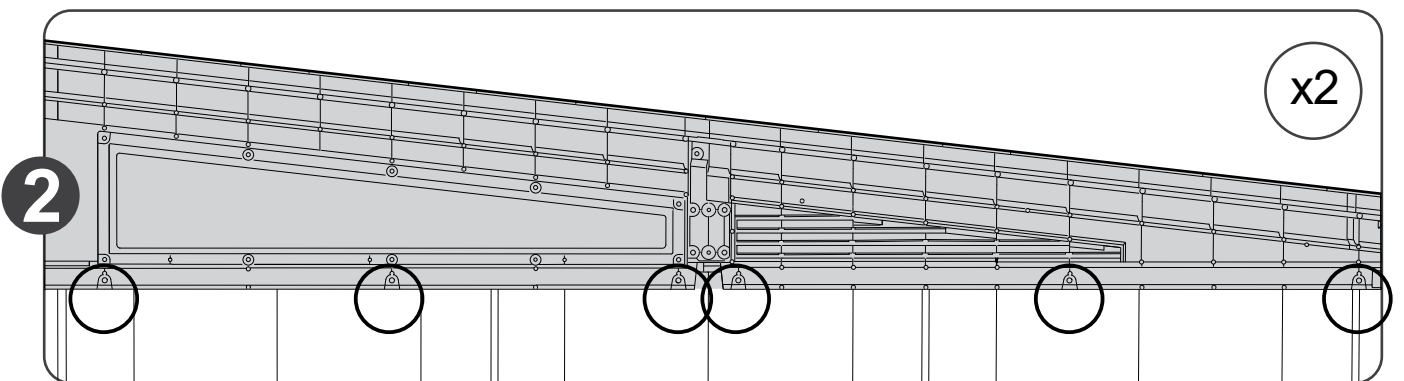

49



s13b (x15)

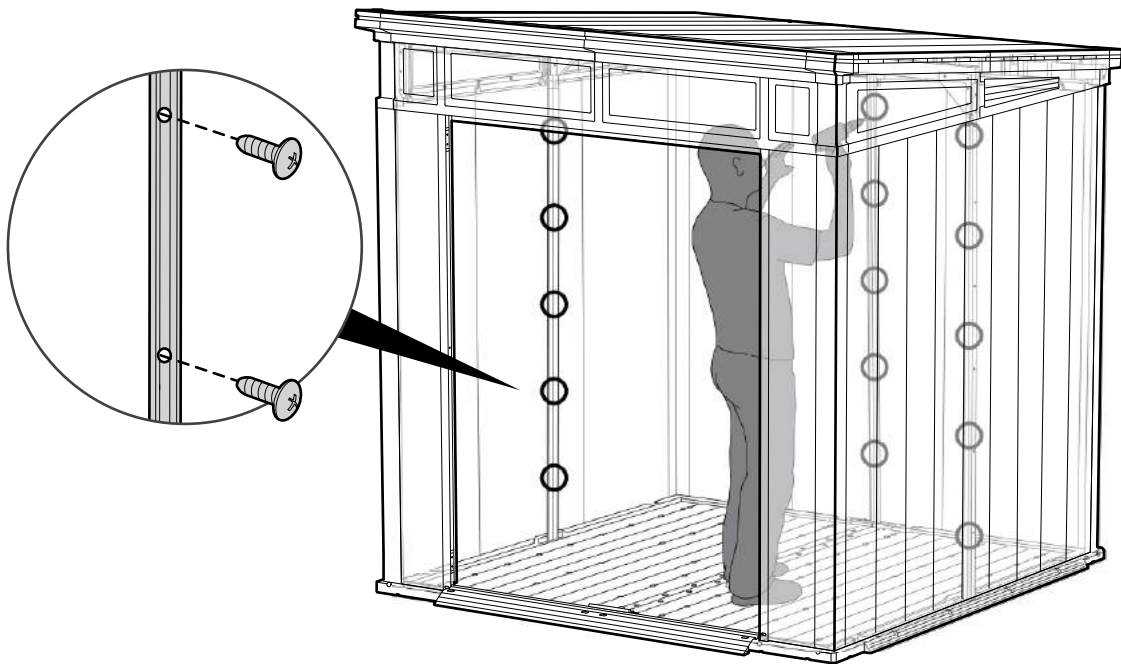

50



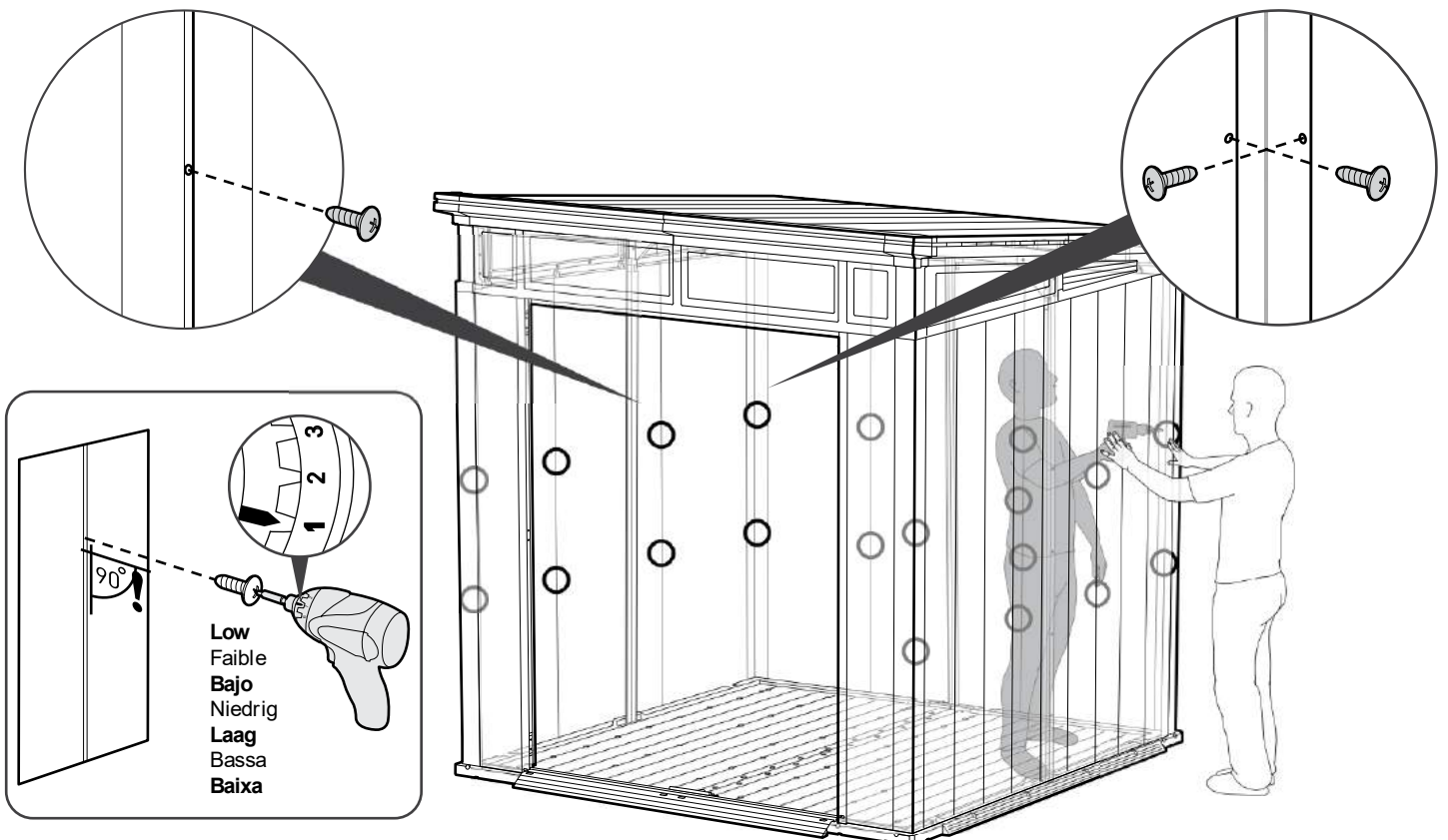

s13b (x28)

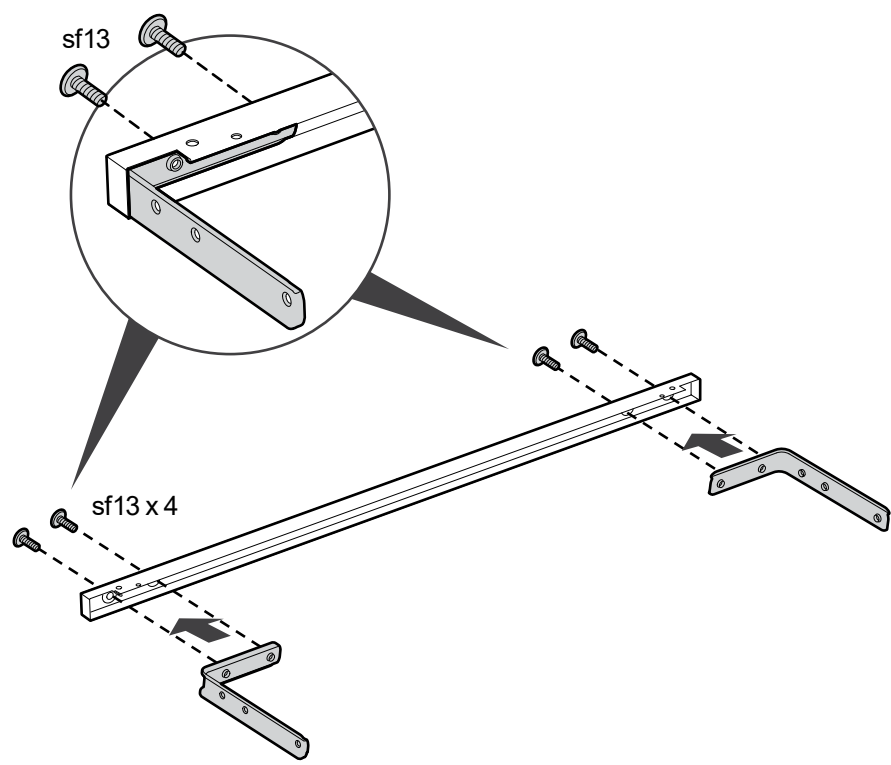

**51** |  NEDC (x4) |  NEDMC (x8) |  sf13 (x16)

x4



**52** |  NEDO (x2)

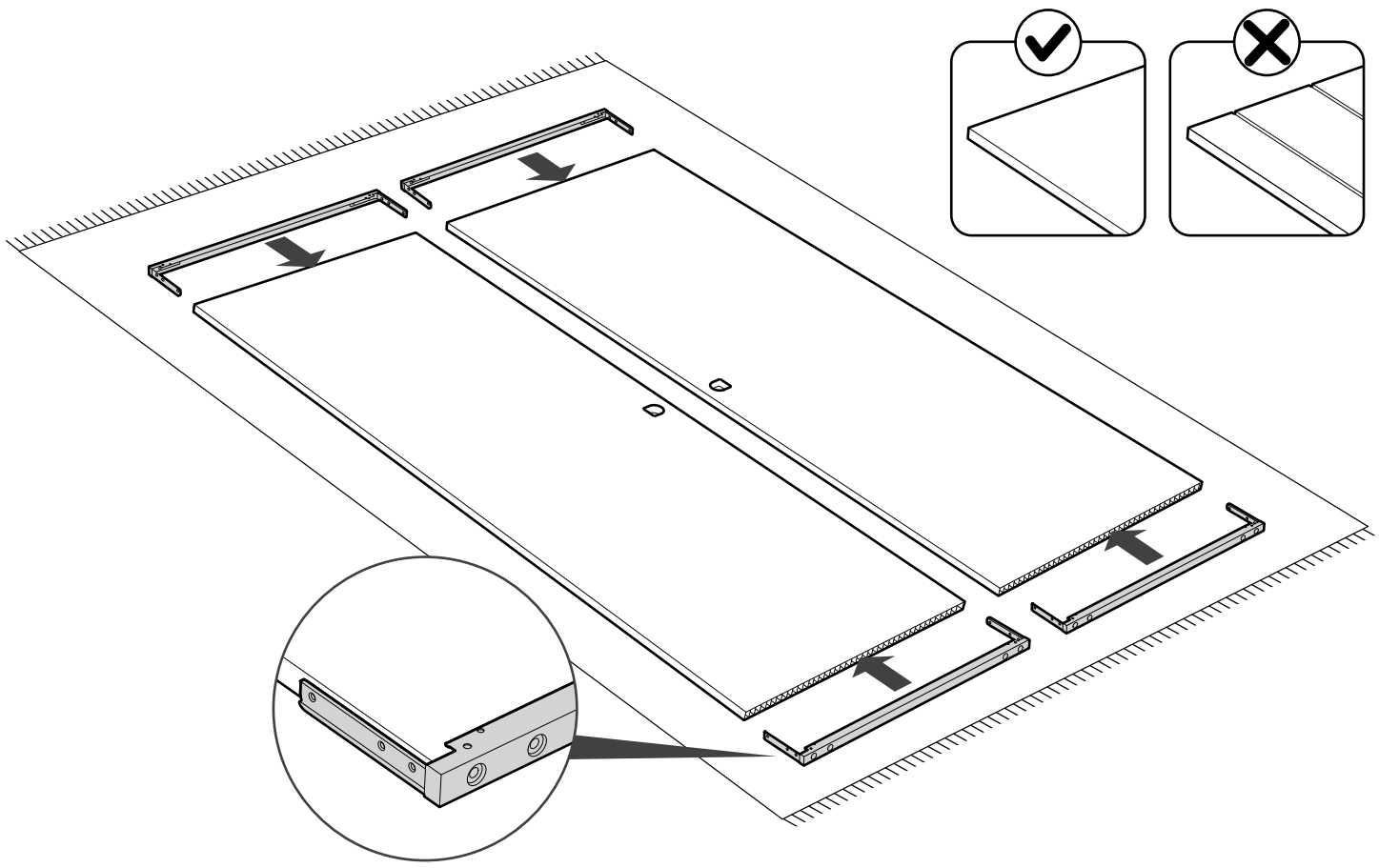

53

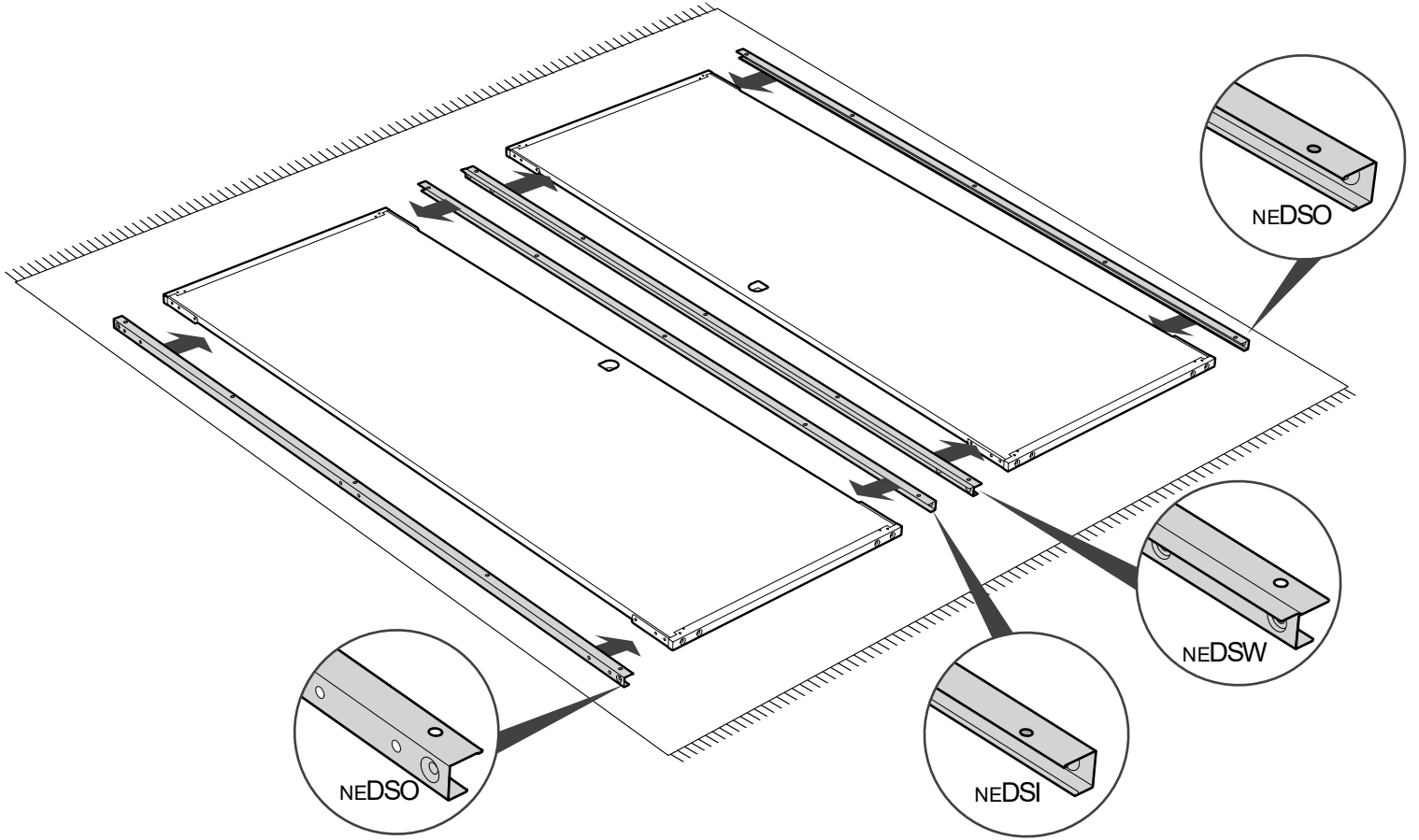

54

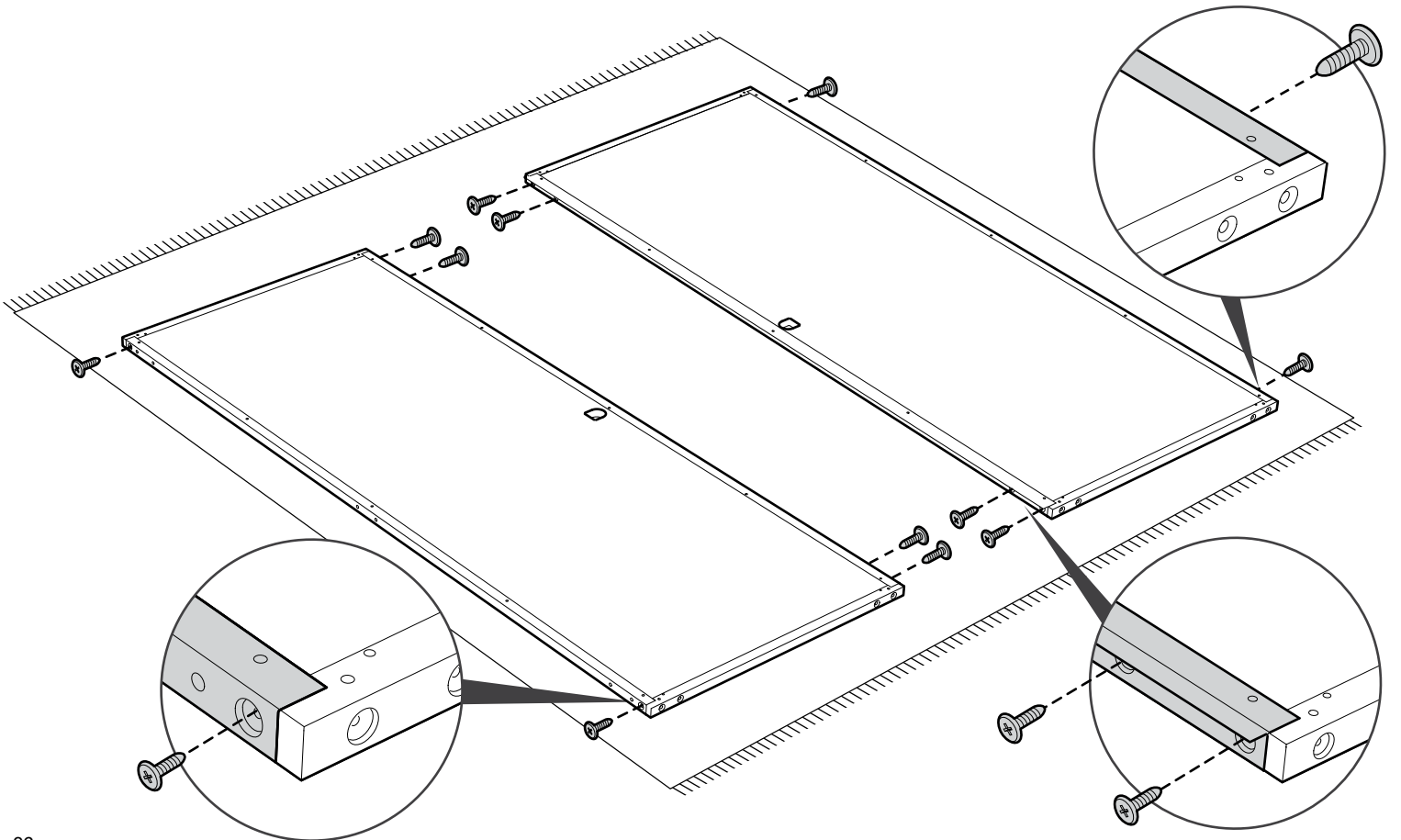

55

NEMBH (x2)

sc15 (x4)

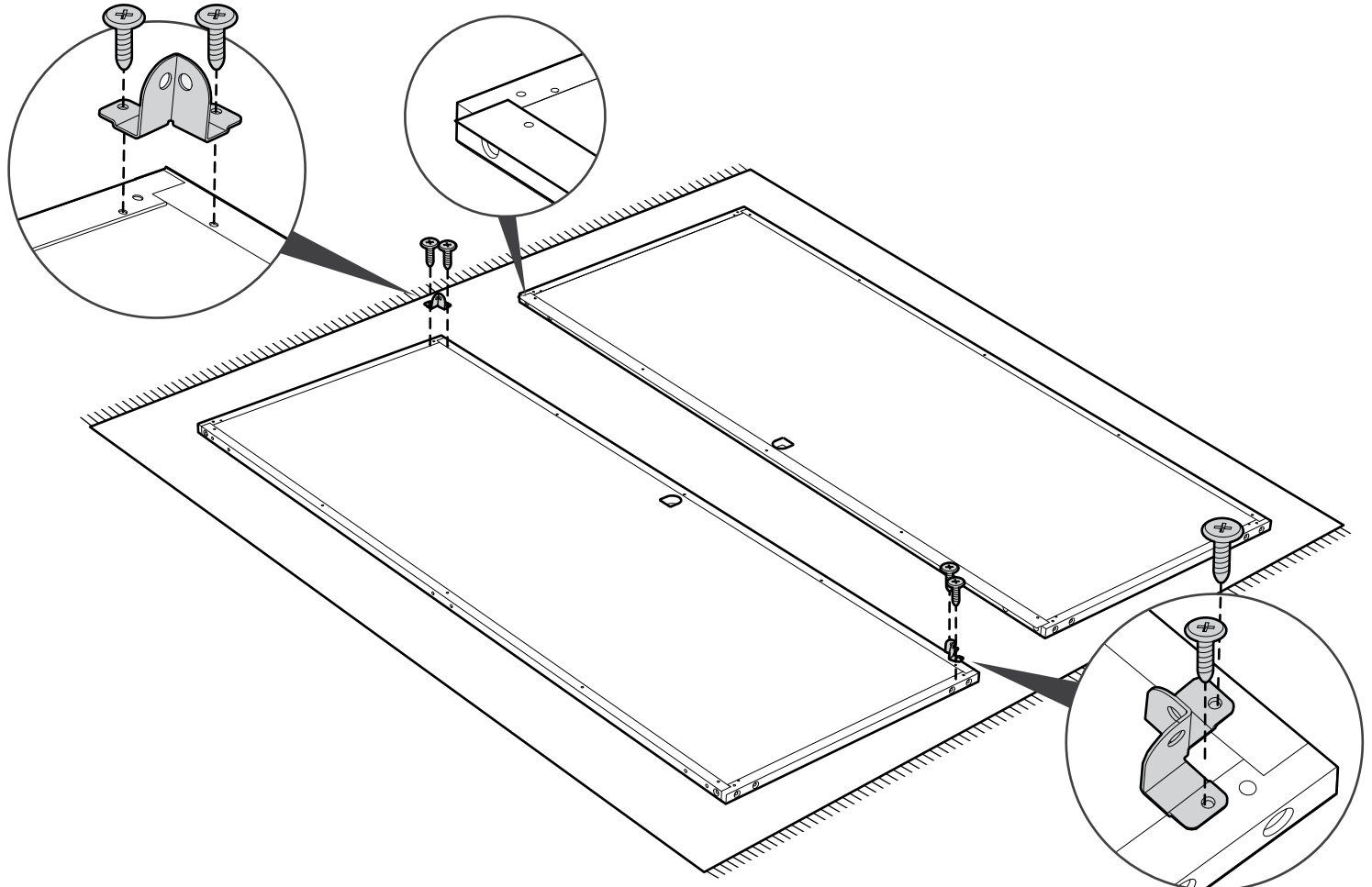

56

sc15 (x26)

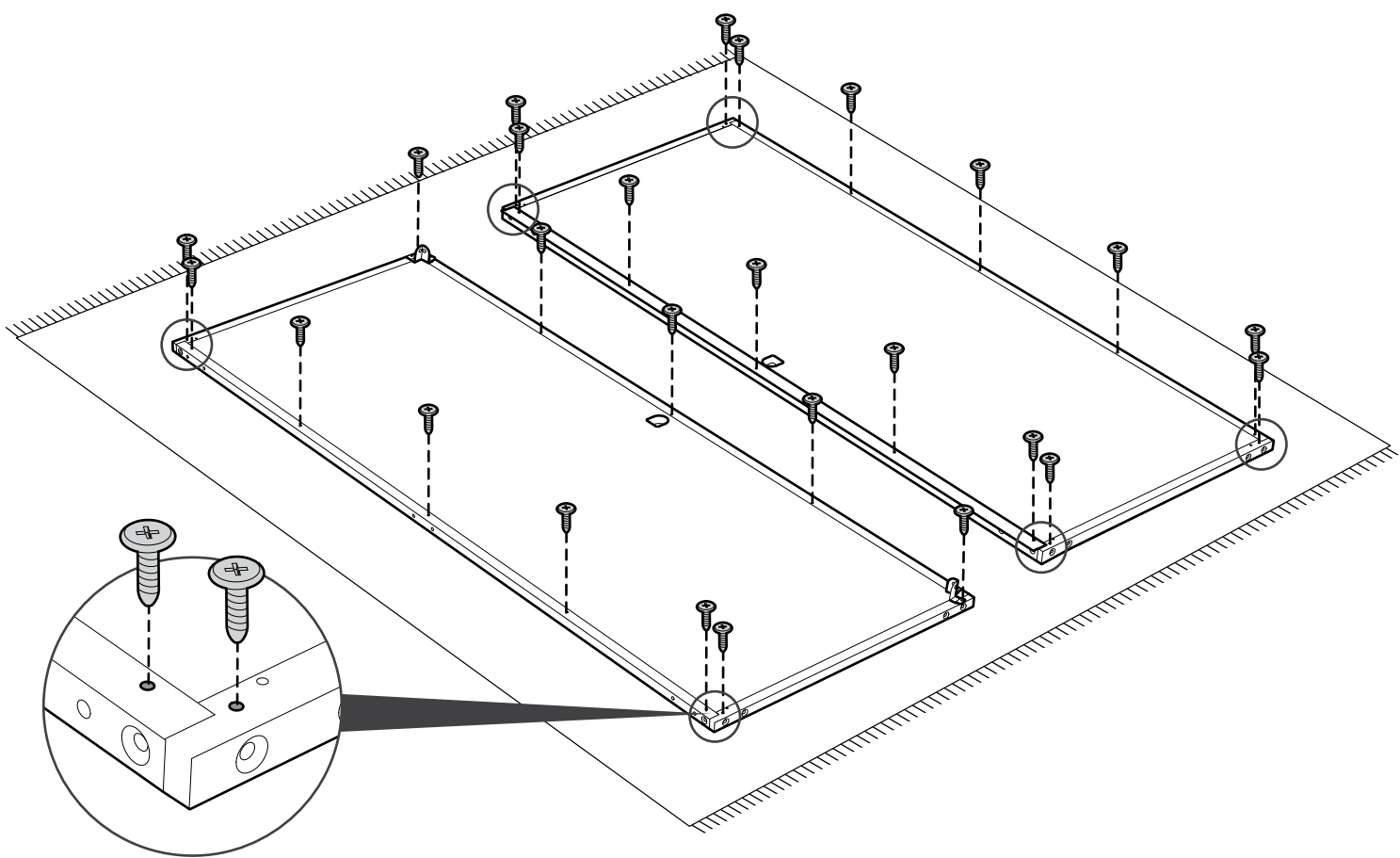

57



NEDH (x6)



sc15 (x12)

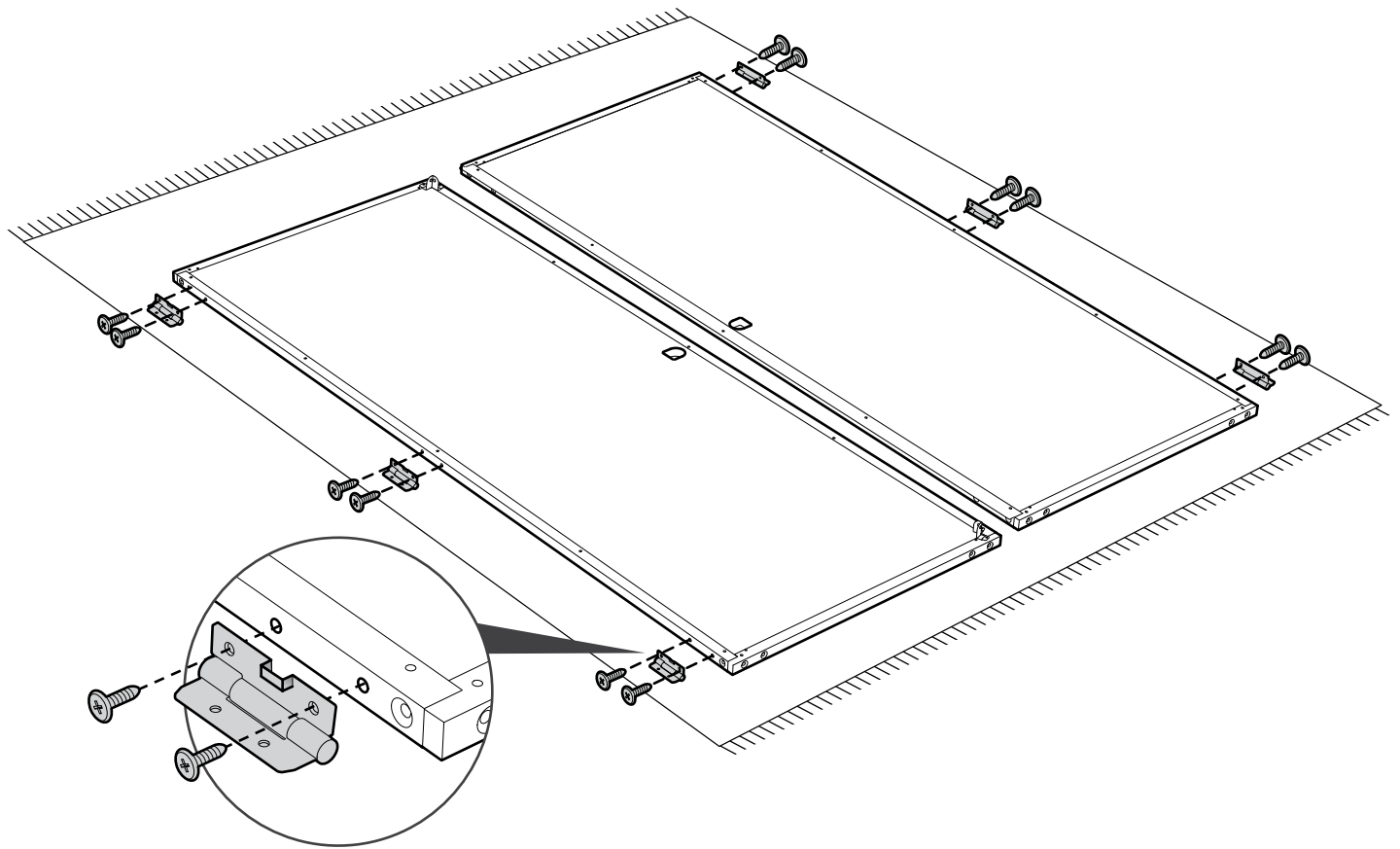

58



sc15 (x2)

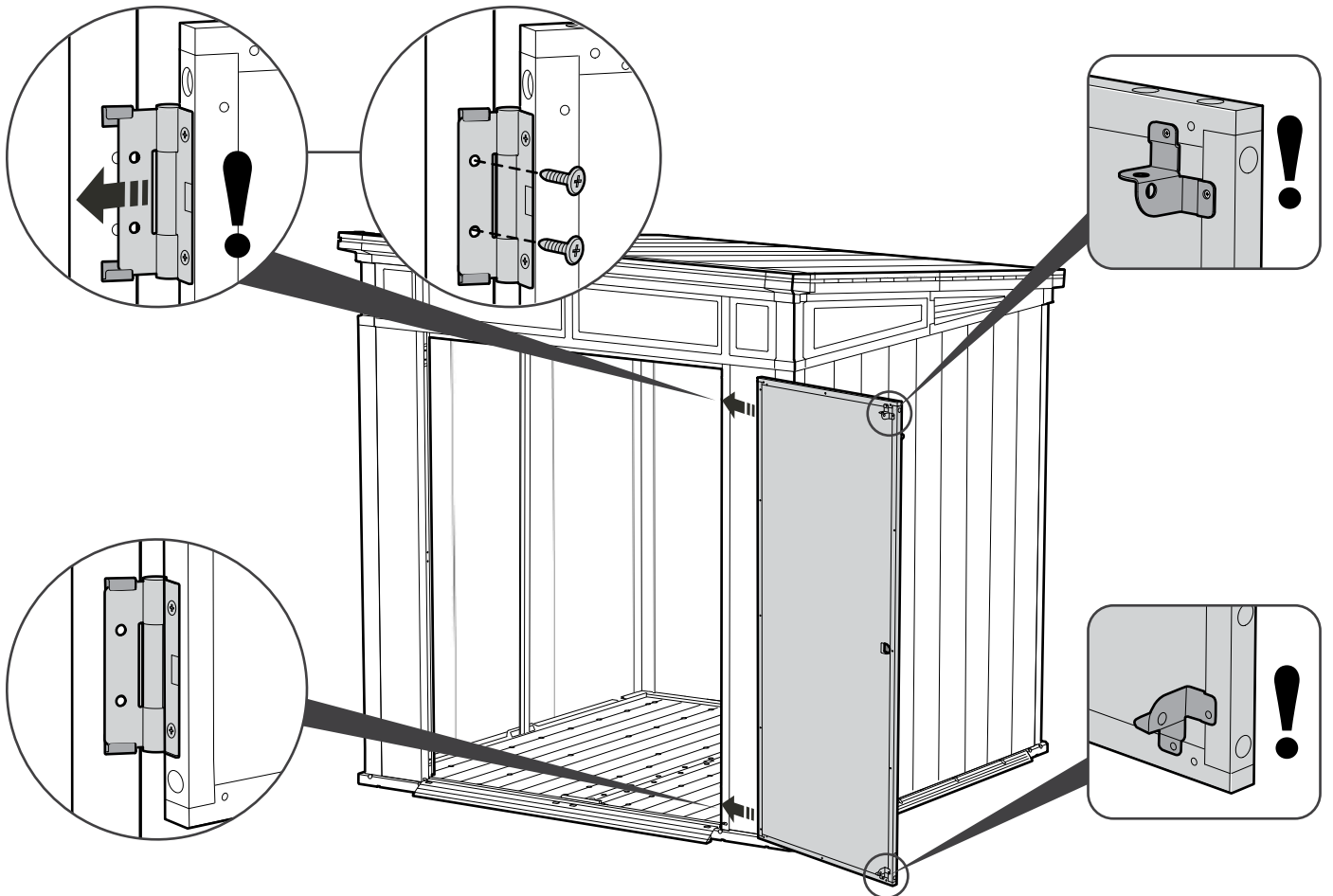

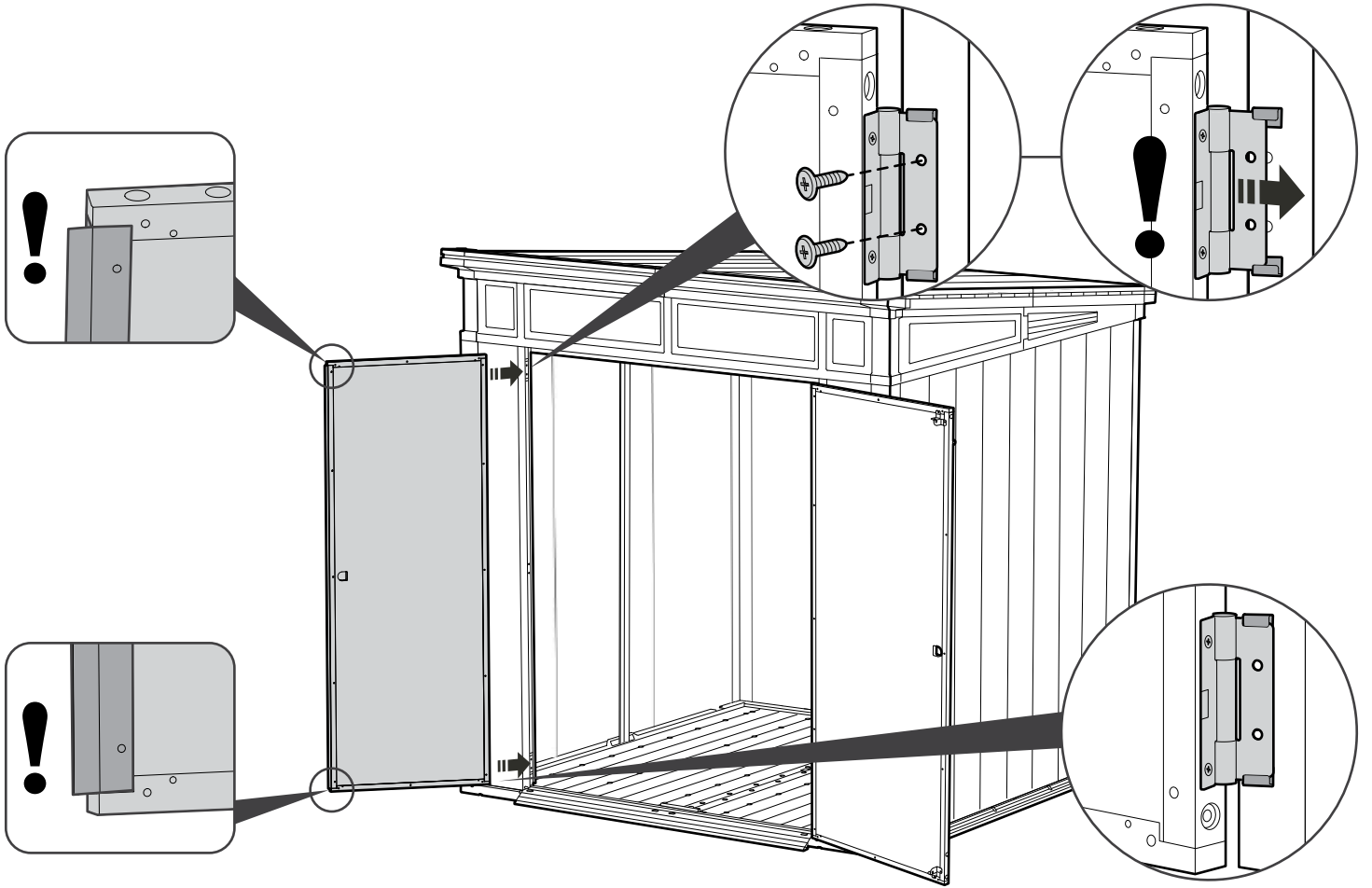

60



NEDPC (x2)



sc15 (x4)

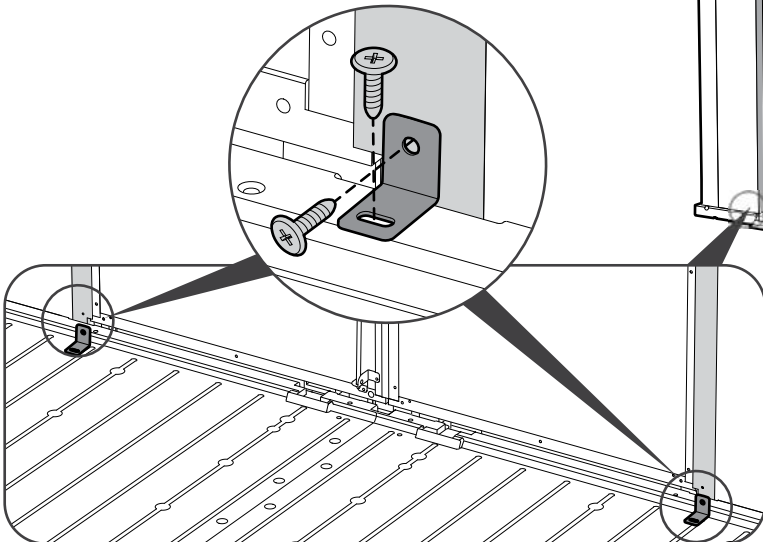
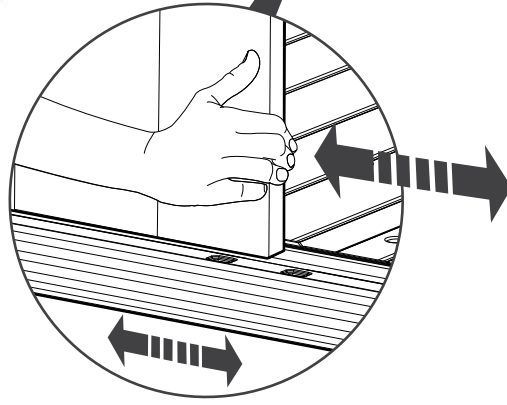
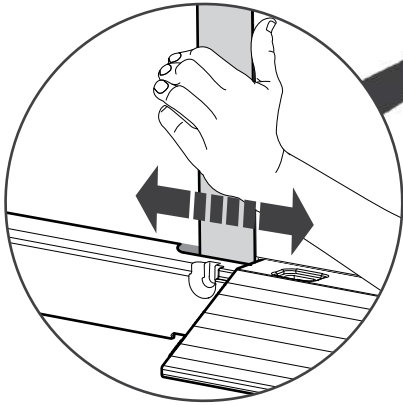
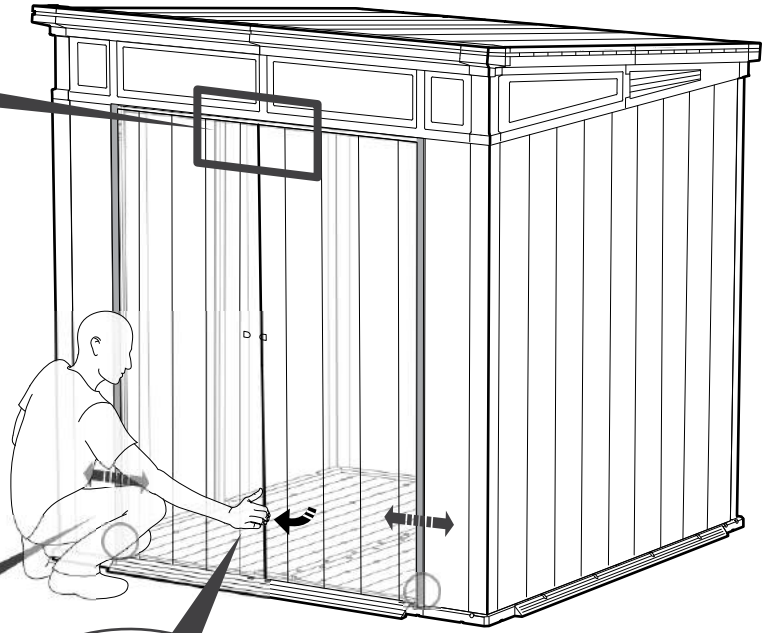
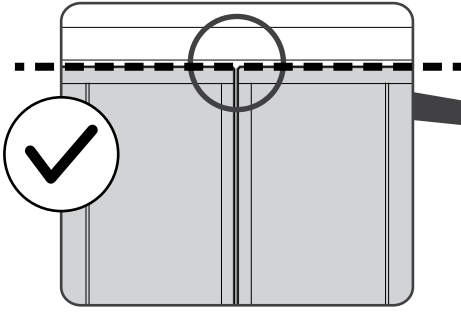



61

 sc15 (x8)

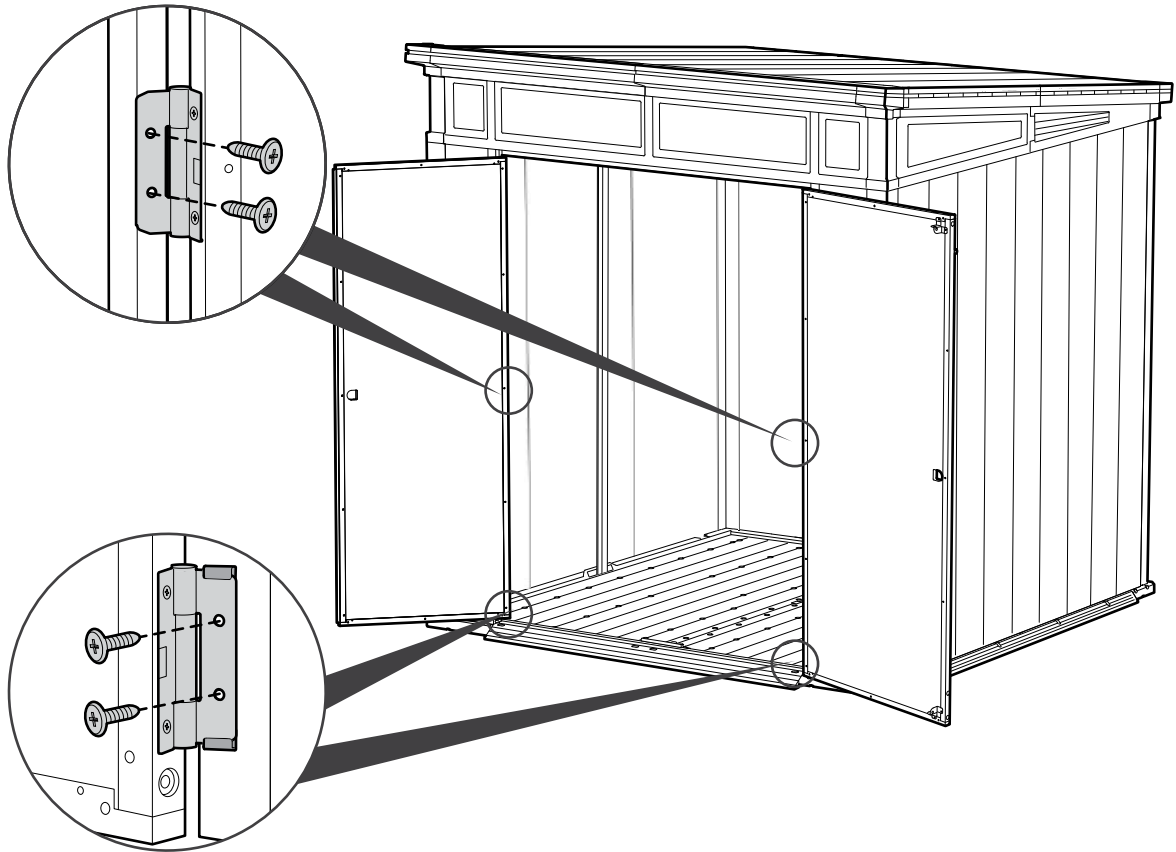

62

 sc15 (x8)

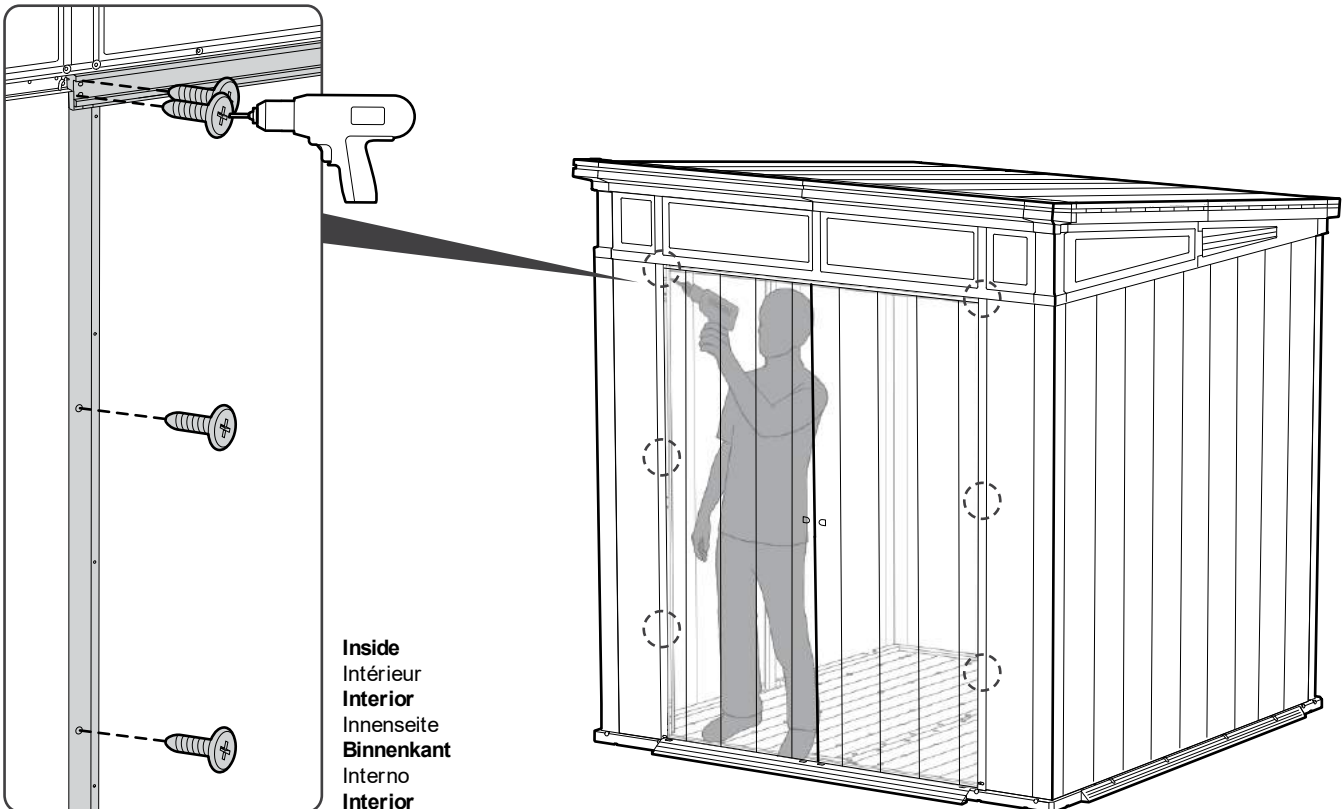

63

 sc15 (x8)

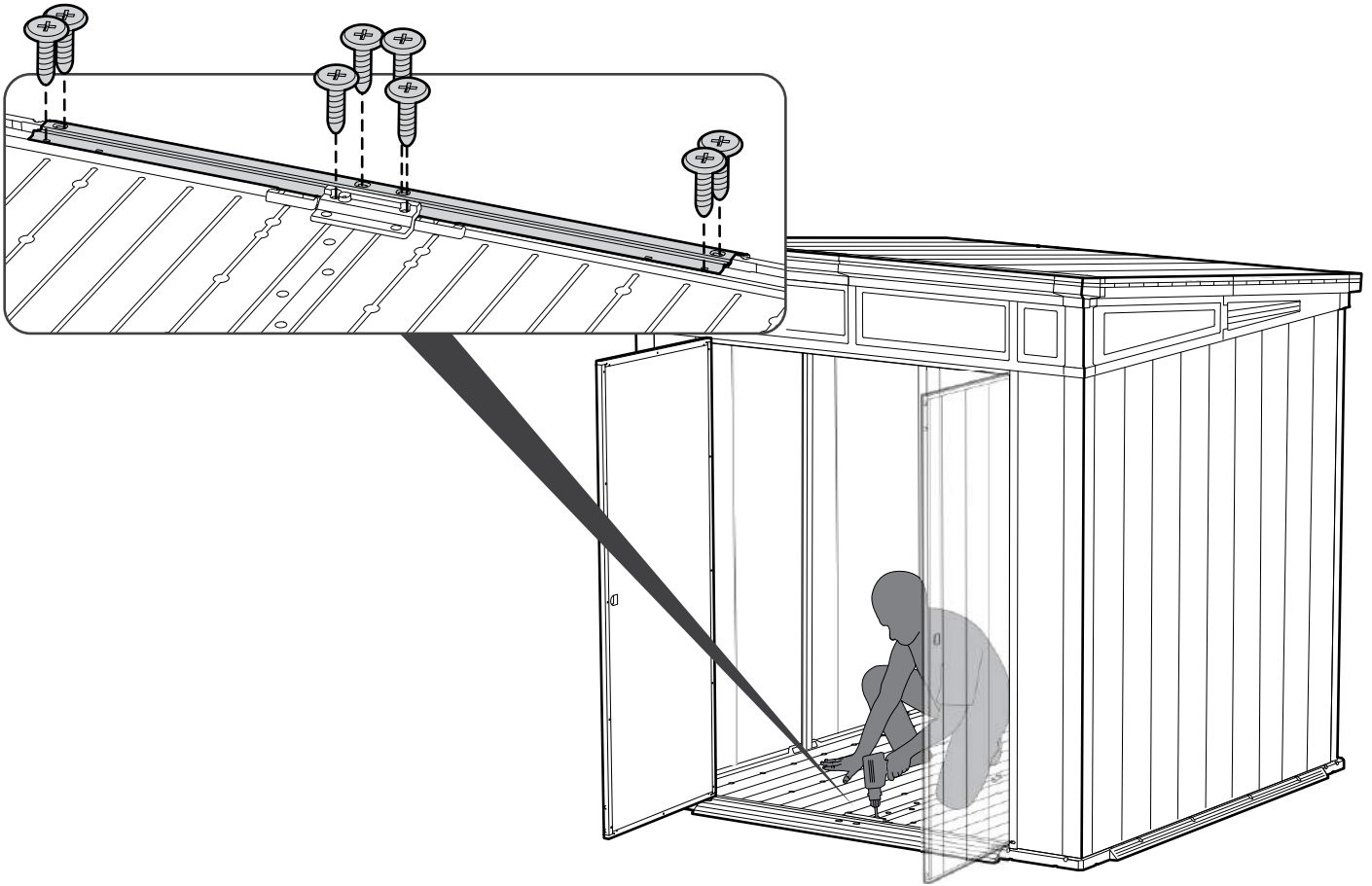

64

 NEHE (x1)

 FNH6 (x1)

 NEHF (x1)

 sc15 (x1)

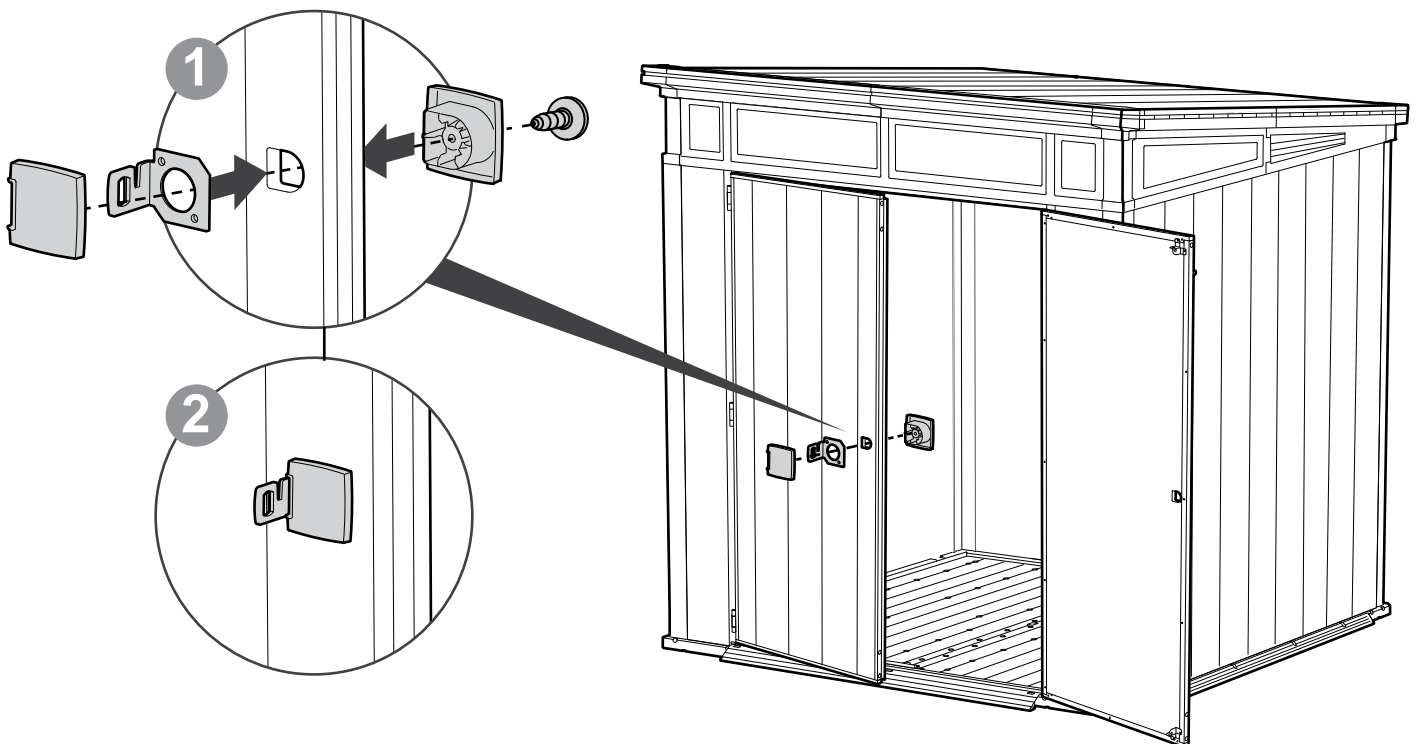

65

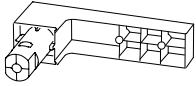

NEHA (x1)

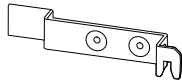

FNH7 (x1)



scn8 (x1)



sc15 (x2)

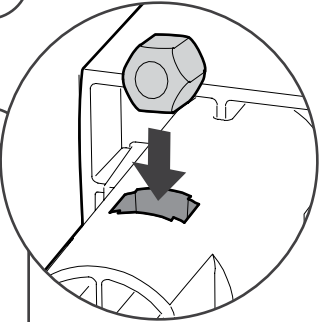
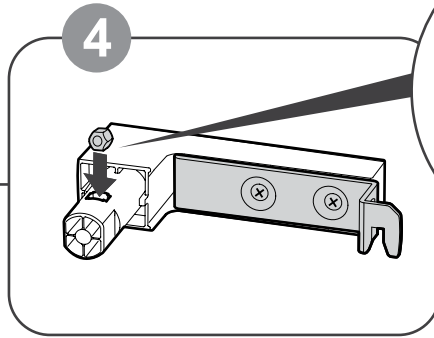
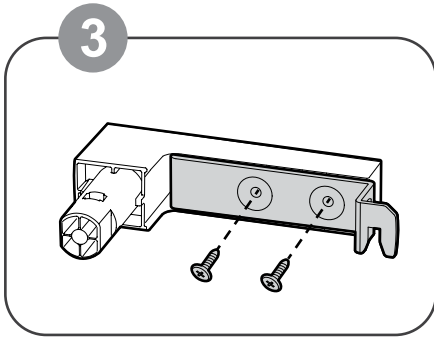
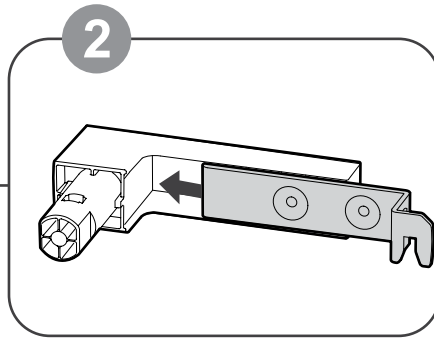
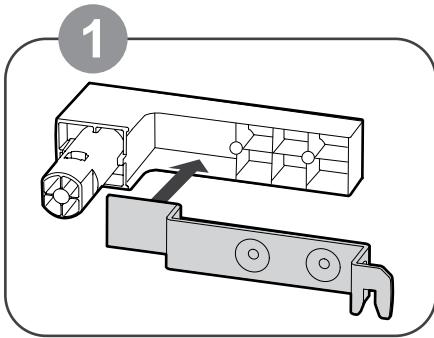

66



NEHB (x1)



NEHC (x1)



NEHG (x1)



sc8 (x1)

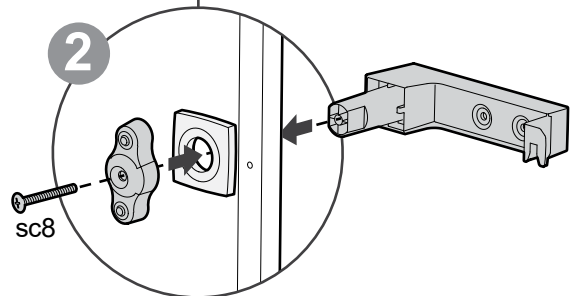
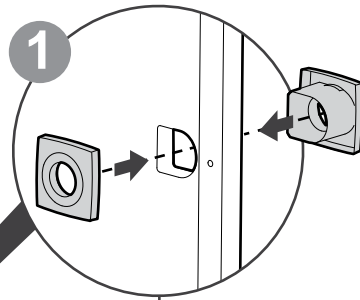
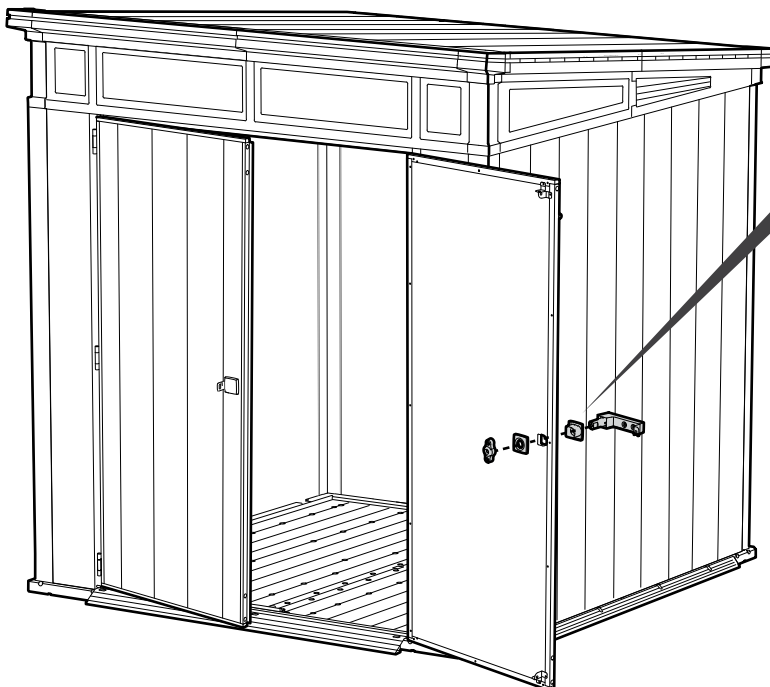

67

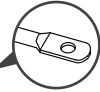

NEMB (x2)



sc15 (x2)

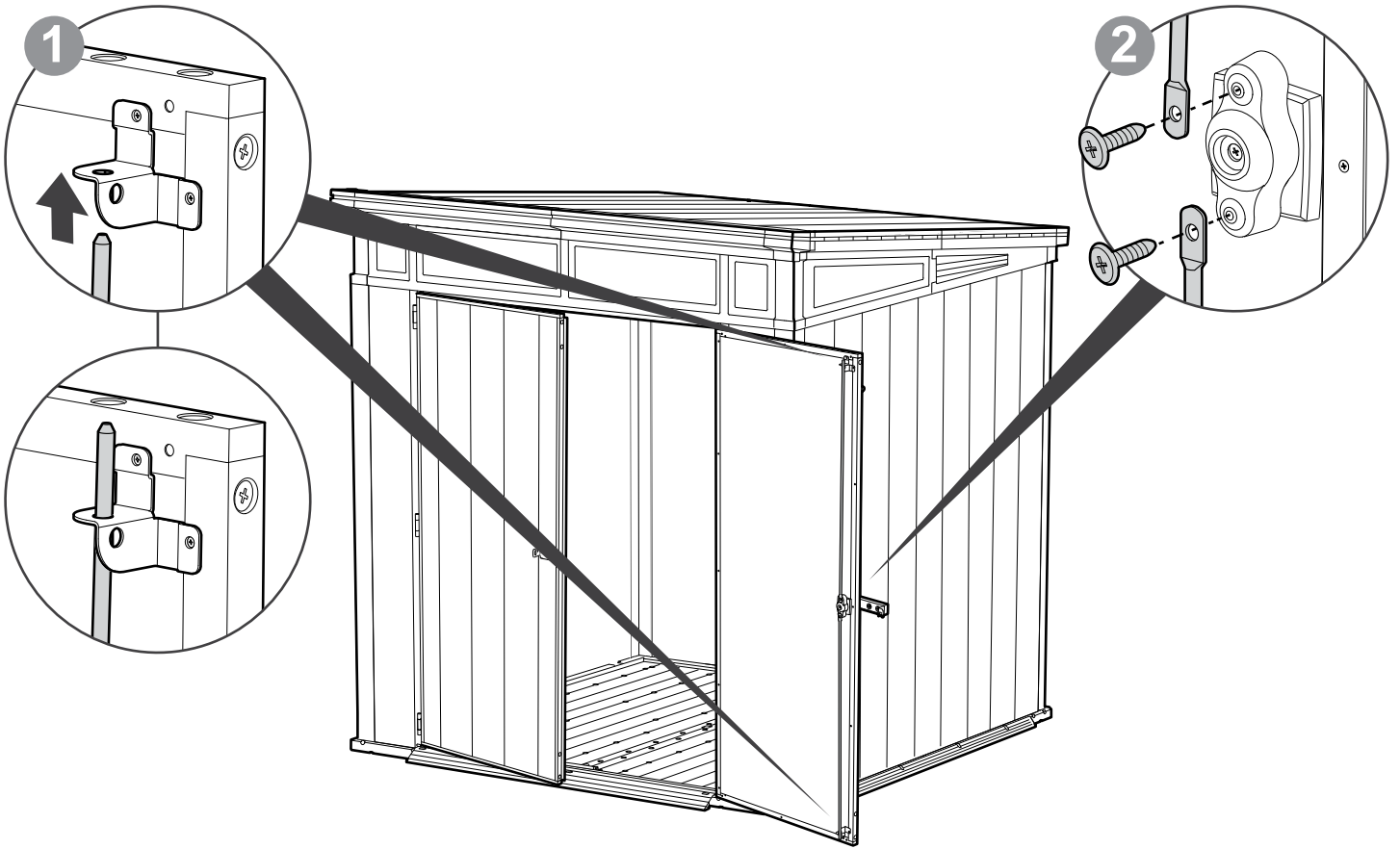

68



sc12 (x28)

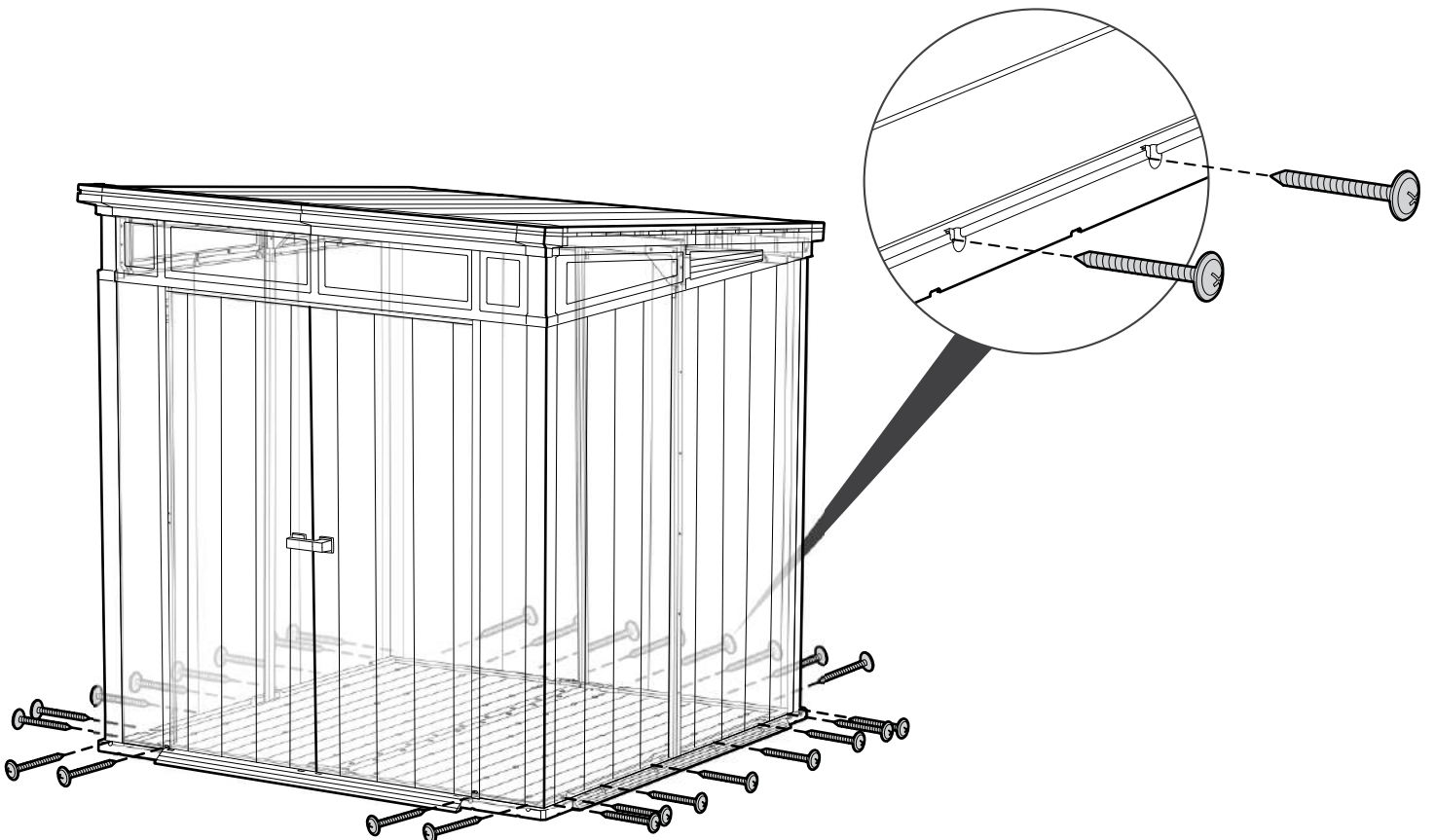

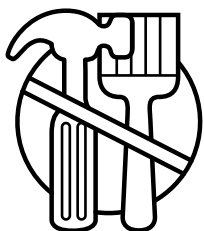

This shed is maintenance free. Paint or varnish are not necessary.  
Cet abri ne nécessite aucun entretien. Peindre ou vernir n'est pas nécessaire.  
El cobertizo no necesita mantenimiento. Tampoco hay que pintarlo ni barnizarlo.  
Dieser Schuppen benötigt keine Wartung. Streichen oder Lackieren ist nicht notwendig.  
Dit schuurtje is onderhoudsvrij. Het is niet nodig het te schilderen of te lakken.  
Questo deposito attrezzi non richiede manutenzione. Non sono necessari pittura o vernici.  
Este abrigo não requer manutenção. A pintura ou o envernizamento não são necessárias.



#### KETER DUOTECH™ SHEDS - UNIQUE PAINTABLE WALLS

This maintenance-free shed is made of a unique compound which enables the brushed wall-panels to be painted.  
The shed can be used in its original color, or the walls can be painted to match your landscape, deck, patio, or outdoor setting.  
Prior to painting, refer to the detailed care and maintenance instructions:

- Type of paint: The walls of the shed can be painted with a water-based acrylic paint for exterior use. Recommended: Solid, light shades, satin or semi-gloss finish. Consult with your color consultant or paint professional when choosing paint.
- Application: Use a roller to apply the paint on the wall dry surface. Do not paint the beam-like crevices in the walls.
- Do not paint windows, doors or door beam, roof, floor, or any other part of the shed.

Keep in mind: Painting requires maintenance. After some time, repainting may be required.  
\* For your safety - make sure you follow the paint's care & safety guide prior to application.

#### ABRIS KETER DUOTECH™ - PAROIS POUVANT ÊTRE PEINTES

Ce placard n'a pas besoin d'aucun entretien et est fait d'un composé unique permettant de peindre les panneaux muraux brossés.  
Le placard de jardin peut être utilisé dans sa couleur d'origine, ou les murs peuvent être peints pour s'harmoniser avec le paysage, la terrasse, le patio ou les éléments extérieurs. Avant de peindre, consultez les instructions détaillées et le mode d'emploi :

- Type de peinture : les murs de l'abri peuvent être peints avec une peinture acrylique à base d'eau prévue pour l'extérieur. Recommandation : finitions en teintes unies, tons clairs, satinés ou semi-lustrés. Suivez les indications de votre conseiller ou votre peinture lors de votre choix.
- Application : utilisez un rouleau pour appliquer la peinture sur la surface bien sèche des murs. Ne peignez pas les éléments de support dans les murs.
- Ne peignez ni les fenêtres, ni les portes ou le tour de porte, ni le toit, ni le sol, ni aucun autre élément constituant de l'abri (seulement les murs).

Rappelez-vous : la peinture exige un certain entretien. Après un certain temps, il peut être nécessaire de repeindre.  
\* Pour votre propre sécurité, suivez bien les instructions d'utilisation de la peinture avant la première application.

#### COBERTIZOS KETER DUOTECH™ - PAREDES PINTABLES ÚNICAS

Esta caseta que no requiere mantenimiento, está hecha de un compuesto único que permite pintar las paredes. La caseta se puede utilizar con su color original o se pueden pintar las paredes para que combinen con el entorno, el patio o los alrededores.  
Antes de pintarlo, consulte las instrucciones detalladas de cuidado y mantenimiento:

- Tipo de pintura: Las paredes del cobertizo se pueden pintar con una pintura acrílica de base acuosa para uso en exteriores. Se recomienda: sólida, sombras ligeras, satinada o con un acabado de semibrillo. Consulte con su profesional de pinturas cuando vaya a elegir una pintura.
- Aplicación: Utilice un rodillo para aplicar la pintura sobre la superficie seca de la pared. No pinte las hendiduras similares a vigas de las paredes.
- No pinte ventanas, puertas o vigas de la puerta, el suelo o cualquier otra parte del cobertizo.

Tenga en cuenta: pintar requiere mantenimiento. Después de algún tiempo podría necesitar otra mano de pintura.  
\* Para su seguridad, asegúrese de que sigue la guía de cuidado y seguridad de la pintura antes de su aplicación.



### KETER DUOTECH™ GARTENHAUS - INDIVIDUELL ANSTREICHBARE WÄNDE

Dieser wartungsfreie Schrank besteht aus einer einzigartigen Verbindung, welches es ermöglicht, die gebürsteten Wandpaneele zu streichen.

Sie können den Schrank in seiner ursprünglichen Farbe nutzen oder dessen Wände streichen, um ihn der Landschaft, Terrasse oder Umgebung anzupassen.

Bitte lesen Sie vor dem Streichen die ausführlichen Wartungs- und Pflegehinweise:

- Art der Farbe: Die Wandpaneele können mit einer Acrylfarbe auf Wasserbasis angestrichen werden. Unsere Empfehlung: Solide und helle Farbtöne mit mattem oder seidenmattem Finish. Sprechen Sie bezüglich Ihrer Farbwahl mit einem Farbberater oder einem professionellen Maler.

- Applikation: Verwenden Sie eine Farbrolle, um die Farbe auf die trockene Wandoberfläche aufzutragen. Bitte streichen Sie nicht die Zwischenräume der einzelnen Paneele.

- Fenster, Türen, Türträger, Dach, Boden und jegliche andere Teile des Gartenhauses bitte nicht anstreichen!

Bitte beachten Sie: Streichen erfordert Instandhaltung und Pflege. Daher kann nach einiger Zeit ein Neuanstrich erforderlich sein.

\* Achtung: Beachten Sie vor dem Streichen die Pflege- und Sicherheitshinweise der Farbe.

### KETER DUOTECH™-SCHUURTJES - UNIEKE SCHILDERBARE MUREN

Dit onderhoudsvrije stal wordt gemaakt van een unieke verbinding die de geborstelde wand-panels worden geleverd mogelijk maakt.

De schuur kan worden gebruikt in de originele kleur, of de wanden kunnen worden geschilderd om uw landschap, dek patio of outdoor setting, overeenkomen.

Voordat u gaat schilderen, verwijzen we u naar de gedetailleerde aanwijzingen voor verzorging en onderhoud:

- Type verf: de muren van het tuinhuis kunnen met een acrylverf op waterbasis voor buitengebruik worden geschilderd. Aanbevolen: stevige, lichte tinten, satijnglans of semi-glanzende afwerking. Raadpleeg uw kleurenadviseur of een professionele schilder bij het kiezen van de verf.

- Toepassing: gebruik een roller om de verf op de droge ondergrond van de muur aan te brengen. Schilder de balkachtige nerven in de muren niet.

- Schilder de ramen, deuren of de deurpost, het dak of enig ander deel van de schuur niet.

Houd er rekening mee dat schilderen onderhoud behoeft. Na enige tijd moet u het overschilderen.

\* Voor uw veiligheid moet u ervoor zorgen dat u de zorg- en veiligheidsinstructies van de verf opvolgt voordat u deze gaat gebruiken.

### PORTA ATTREZZI KETER IN DUOTECH™ - PANNELI VERNICIABILI

Questa capannone è senza manutenzione e è realizzata con un composto unico che consente che i pannelli spazzolati dei muri siano pitturati.

Il capannone può essere utilizzata con il colore originario, oppure le pareti possono essere dipinte per adattarsi meglio all'ambiente circostante.

Prima di dipingere, fare riferimento alle istruzioni dettagliate su cura e manutenzione:

- Tipo di vernice: le pareti della casetta possono essere dipinte con una vernice acrilica ad acqua per uso esterno. Raccomandiamo: tinta poco diluita, ombreggiature leggere, rifiniture lucide o semilucide. Consultare un consulente per verniciature o un tinteggiatore professionista al momento di scegliere la vernice.

- Applicazione: utilizzare un rullo per applicare la vernice sulla superficie delle pareti a secco. Non dipingere le rientranze simili a putrelle sui muri.

- Non dipingere finestre, porte o la trave della porta, il tetto, il pavimento o qualsiasi altra parte della casetta.

Avvertenza: dipingere richiede manutenzione. Dopo qualche tempo potrebbe essere necessaria una ritinteggiatura.

\* Per la vostra sicurezza - assicurarsi di seguire la cura e la sicurezza la guida vernice prima dell'applicazione.

### DEPOSITO KETER DUOTECH™ - PAREDES ÚNICAS PINTÁVEIS

Este galpão isento de manutenção é fabricado a partir de um composto exclusivo que permite a pintura dos painéis escovados da parede.

O galpão pode ser usado em sua cor original, ou as paredes podem ser pintadas para combinar com sua paisagem, terraço, pátio ou configuração ao ar livre. Antes de pintar, leia as instruções detalhadas sobre os cuidados e a manutenção:

- Tipo de pintura: As paredes do galpão podem ser pintadas com uma tinta acrílica à base de água para uso exterior. Recomendado: Tons claros, sólidos, acabamento de semi-brilho ou cetim. Fale com o seu consultor de cor ou pintor profissional na escolha da pintura.

- Aplicação: Use um rolo para aplicar a tinta sobre a superfície seca da parede. Não pinte os cervices como feixe nas paredes.

- Não pinte janelas, portas ou feixe de porta, telhado, piso, ou qualquer outra parte do galpão.

Lembre-se: Pintura requer manutenção. Depois de algum tempo, pode ser necessário pintar novamente.

\* Para sua segurança - certifique-se de seguir o guia de cuidados e segurança da tinta antes da aplicação.

### SECURING THE SHED TO A FOUNDATION

Affix the shed to the foundation by drilling holes in the shed floor at the pre-marked locations and screwing it into the foundation using appropriate screws (screws not included).

### FIXER L'ABRI SUR UNE FONDATION

Fixez l'abri à la fondation en perçant des trous dans le sol aux endroits pré-marqués et en insérant des vis adéquates dans la fondation (vis non fournies).

### ASEGURAR EL COBERTIZO A UN CIMIENTO

Fije el cobertizo a los cimientos perforando agujeros en el suelo del cobertizo en los lugares previamente marcados y atorníllelo a los cimientos utilizando los tornillos adecuados (los tornillos no están incluidos).

### ABSICHERN DES SCHUPPENS AN EIN FUNDAMENT

Bringen Sie den Schuppen auf dem Fundament an, indem Sie an den Markierungen Löcher in den Schuppenboden bohren und diesen mit passenden Schrauben auf dem Fundament festschrauben (Schrauben nicht enthalten).

### HET SCHUURTJE OP HET FUNDAMENT VASTZETTEN

Bevestig het schuurtje aan de fundering door op de aangegeven plaatsen gaten te boren in de vloer van het schuurtje en het schuurtje aan de fundering te schroeven met behulp van passende schroeven (schroeven niet inbegrepen).

### ASSICURARE LA COPERTURA ALLE FONDAMENTA

Fissa il deposito attrezzi alle fondamenta facendo dei fori nel pavimento nelle posizioni pre-segnalate ed avvitandolo alle fondamenta utilizzando apposite viti (viti non incluse).

### FIXAR O ABRIGO NUMA FUNDAÇÃO

Afixe o abrigo à base abrindo buracos no chão nos locais previamente assinalados e aparafusando-o à mesma utilizando parafusos adequados (os parafusos não estão incluídos).

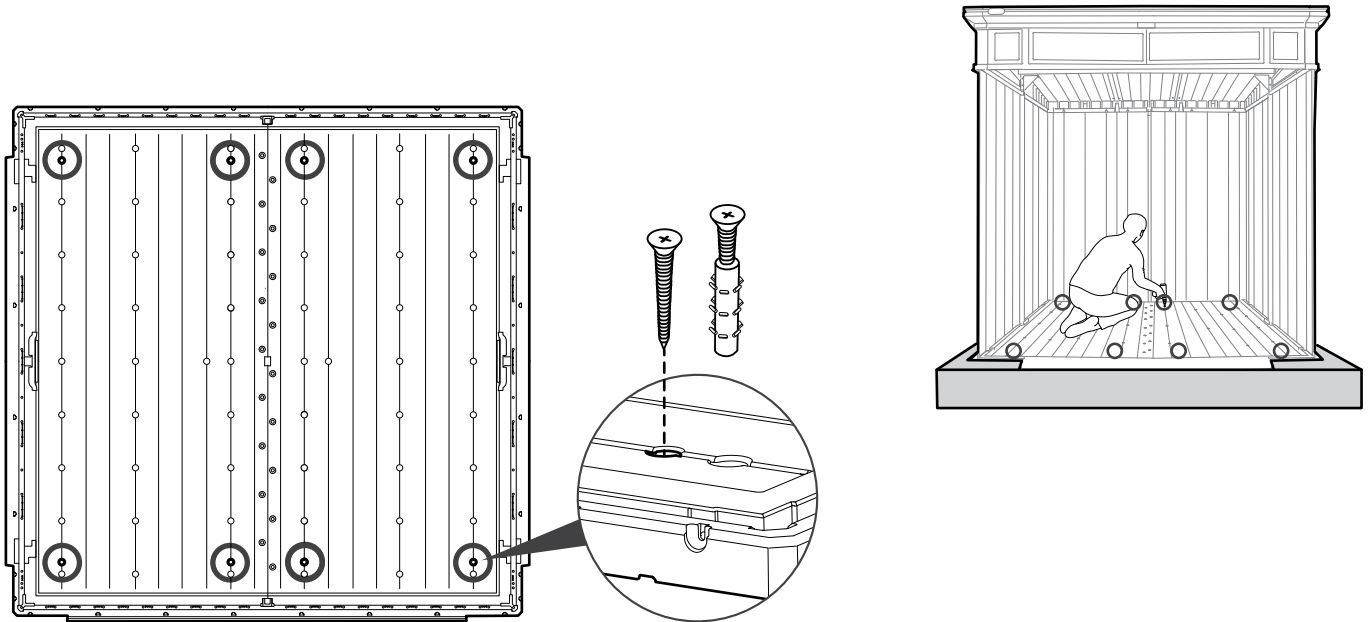

### CARE AND SAFETY GUIDELINES

- The shed is intended for storage purposes only. It is not designed for habitation.
- It is strongly recommended to secure the shed to an immovable object or anchor to the ground by drilling holes in the shed floor (at the pre-marked locations) and inserting proper screws into the ground (screws are not included).
- Do not attempt assembly on windy or cold days.
- Periodically check the shed to ensure that it is stable and that the site is level.
- Be careful when handling parts with steel edges.
- When assembling or handling the shed, use only those tools listed in the user manual.
- Always wear work gloves, safety goggles and long sleeves when assembling or performing any maintenance on your shed.
- Avoid using a lawnmower or mechanical scythe near the shed.
- Wear safety goggles and always follow the manufacturer's instructions when using power tools.
- Wash the shed with a garden hose or a mild detergent solution. Do not use a stiff brush or abrasive cleaners, including degreasers and oil- or acetone-based cleaning materials, as these may stain or damage the shed.
- Do not store hot items, such as recently used grills and blowtorches, and volatile chemicals in the shed.
- Avoid placing heavy items against the walls, as this may cause distortion.
- Keep the roof clear of accumulated snow and leaves. Large amounts of snow on the roof can damage the shed, making it unsafe to enter.
- Wind direction is an important factor to consider when determining the location of the shed. Reduce exposure to the wind, in general, and of the door side in particular. Keep doors closed and locked when the shed is not in use to prevent wind damage.
- Do not stand on the roof.
- Consult your local authorities to check if permits are required to erect the shed.

## INSTRUCTIONS DE SÉCURITÉ ET D'ENTRETIEN

- L'abri a été conçu uniquement à des fins de stockage. Il n'a pas été conçu à des fins d'habitation.
- Il est fortement recommandé de sécuriser l'abri à un objet inamovible ou de le fixer au sol en creusant des trous dans le sol de l'abri (aux emplacements marqués) et d'insérer les vis adaptées dans le sol (vis non incluses).
- N'essayez pas de réaliser le montage par jour venteux ou froid.
- Vérifiez de temps en temps la tenue de l'abri afin de garantir sa stabilité et la mise à niveau du site, sur lequel il est posé.
- Manipulez les pièces présentant des bords en acier avec précaution.
- Lors de l'assemblage ou de la manipulation de l'abri, utilisez seulement les outils listés dans le mode d'emploi.
- Portez toujours des gants de travail, des lunettes de protection et des vêtements à manches longues lors de l'assemblage ou de l'accomplissement d'activités de maintenance sur votre abri.
- Évitez d'utiliser une tondeuse à gazon ou une faux mécanique à proximité de l'abri.
- Portez des lunettes de sécurité et suivez toujours les instructions du fabricant lors de l'utilisation d'outils électriques.
- Lavez l'abri à l'aide d'un tuyau d'arrosage de jardin ou d'un détergent non abrasif. N'utilisez pas une brosse dure ou de nettoyeurs abrasifs, y compris les dégraissants et les solutions de nettoyage à base d'acétone ou d'huile, car ils peuvent tacher ou endommager l'abri.
- Ne stockez pas d'objets chauds, tels qu'un grill ou un chalumeau récemment utilisé, ou des produits chimiques volatiles dans l'abri.
- Évitez de placer des objets lourds contre les murs de votre abri, cela peut entraîner une déformation.
- Entretenez le toit pour éviter l'accumulation de neige ou de feuilles. Une grande quantité de neige sur le toit peut endommager l'abri, rendant périlleux l'accès à l'intérieur.
- La direction du vent est un facteur important à prendre en compte lors du choix de la localisation de l'abri. Réduisez l'exposition au vent, en général, et surtout pour le côté de la porte. Maintenez les portes fermées et verrouillées lorsque l'abri n'est pas utilisé, afin d'éviter tout dégât dû au vent.
- Ne montez pas sur le toit.
- Consultez les autorités de votre localité pour vérifier la nécessité de disposer d'un permis pour ériger l'abri.

## ADVERTENCIA SOBRE EL CUIDADO Y LA SEGURIDAD

- La cobertizo está diseñada solo para el almacenamiento de productos. No está diseñada para habitar en ella.
- Se recomienda encarecidamente fijar la cobertizo a un objeto inamovible o anclarla al suelo taladrando agujeros en el suelo de la cobertizo (en los lugares premarcadas para ello), e insertando tornillos adecuados en el suelo (los tornillos no están incluidos).
- No intente montarlo en días de viento o cuando haga frío.
- Compruebe la cobertizo periódicamente para asegurarse de que es estable y de que el lugar es uniforme.
- Tenga cuidado al manejar las partes con bordes de acero.
- Al montar o manipular la cobertizo, use solamente las herramientas enumeradas en el manual del usuario.
- Use siempre guantes de trabajo, anteojos protectores y mangas largas para armar el cobertizo o realizar cualquier tarea de mantenimiento en el mismo.
- Evite usar un cortacésped o un cortacésped cerca de la cobertizo.
- Lleve gafas de seguridad y siga siempre las instrucciones del fabricante al utilizar herramientas eléctricas.
- Lave la cobertizo con una manguera de jardín o con un detergente suave. No utilice un cepillo rígido ni limpiadores abrasivos, incluyendo desengrasantes y materiales de limpieza basados en petróleo o acetona, ya que todos ellos pueden manchar o dañar la cobertizo.
- No guarde objetos calientes, como sopletes usados recientemente, ni elementos químicos volátiles.
- Evite situar objetos pesados contra las paredes, ya que esto puede causar deformación.
- Mantenga el techo limpio de nieve y hojas acumuladas. Una gran cantidad de nieve en el tejado puede dañar el cobertizo, haciendo que sea inseguro entrar.
- La dirección del viento es un factor importante a tener en cuenta al determinar la ubicación del cobertizo. Reduzca la exposición al viento en general y al lateral de la puerta en particular. Mantenga las puertas cerradas y bloqueadas cuando no utilice el cobertizo para evitar daños del viento.
- Ne montez pas sur le toit.
- Consulte con sus autoridades locales y son necesarios No se ponga de pie sobre el techo. permisos para levantar el cobertizo.

## PFLEGE - UND SICHERHEITSHINWEISE

- Der Gartenschuppen dient einzig und allein der Lagerung von Gegenständen. Der Schuppen ist nicht für Wohnzwecke ausgelegt.
- Es wird dringend empfohlen, den Schuppen an einem unbeweglichen Gegenstand zu befestigen oder Mithilfe von Löchern im Schuppenboden im Boden zu verankern (die Bohrungen müssen an den vormarkierten Stellen erfolgen), wobei geeignete Schrauben zu verwenden sind (Schrauben sind nicht im Lieferumfang enthalten).
- Führen Sie den Aufbau nicht an windigen oder kalten Tagen durch.
- Überprüfen Sie den Schuppen regelmäßig auf Stabilität und stellen Sie sicher, dass der Standort eben ist.
- Seien Sie vorsichtig, wenn Sie mit Teilen hantieren, die Stahlkanten aufweisen.
- Für Aufbau und Handhabung des Schuppens verwenden Sie bitte nur Werkzeuge, die in der Aufbauanleitung aufgelistet sind.
- Tragen Sie bei der Montage des Gartenschuppens oder Wartungsarbeiten stets Arbeitshandschuhe, eine Schutzbrille und Kleidungsstücke mit langen Ärmeln
- Vermeiden Sie den Einsatz von Rasenmäher und maschineller Sense im direkten Umfeld des Schuppens.
- Tragen Sie eine Schutzbrille und befolgen Sie bei Verwendung von Elektrowerkzeugen immer die Anweisungen des Herstellers.
- Reinigen Sie den Schuppen mit einem Gartenschlauch und einem milden Reinigungsmittel. Verwenden Sie auf keinen Fall eine harte Bürste und Scheuer- oder Entfettungsmittel sowie Öl- oder Acetonhaltige Reinigungsmittel, da diese Flecken verursachen oder den Schuppen beschädigen könnten.
- Lagern Sie keine heißen Gegenstände im Schuppen, wie etwa kürzlich benutzte Grills oder Lötlampen und auch keine flüchtigen Chemikalien.
- Lehnen Sie keine schweren Gegenstände an die Wände des Schuppens, da sich dadurch der gesamte Schuppen verziehen könnte.
- Halten Sie das Dach frei von Schnee und angesammeltem Blattwerk. Große Mengen an Schnee können den Schuppen beschädigen und beim Betreten gefährlich werden
- Die Windrichtung ist ein wichtiger Faktor, der bei der Aufstellung des Schuppens unbedingt berücksichtigt werden muss. Vermeiden Sie zu hohe Windbelastungen, insbesondere einen hohen Winddruck auf die Türen. Halten Sie die Türen immer geschlossen und verriegelt, wenn der Schuppen nicht genutzt wird, um eine Beschädigung durch Windbelastungen zu vermeiden.
- Betreten Sie auf keinen Fall das Dach des Schuppens.
- Wenden Sie sich bitte an Ihre lokale Behörde und erkundigen Sie sich dort, ob zum Aufbau des Schuppens eine Genehmigung erforderlich ist.

## RICHTLIJNEN VOOR ZORG EN VEILIGHEID

- Het tuinhuisje is uitsluitend bedoeld voor opslag. Het is niet ontworpen voor bewoning.
- Het wordt sterk aanbevolen om het tuinhuisje vast te maken aan een immobiel object of in de grond te verankeren door het boren van gaten in de vloer (op de gemarkeerde plaatsen) en het met de geschikte schroeven in de grond te bevestigen (schroeven zijn niet inbegrepen).
- Probeer niet op stormachtige of koude dagen te monteren.
- Controleer het tuinhuisje regelmatig dat het stabiel en waterpas staat.
- Wees voorzichtig als u werkt met onderdelen met staalranden.
- Gebruik bij de montage of het hanteren van het tuinhuisje alleen de gereedschappen die in de handleiding vermeldt staan.
- Draag altijd werkhandschoenen, oogbescherming en lange mouwen als u uw schuurtje monteert of onderhoud



- Vermijd het gebruik van een grasmaaier of mechanische zeis in de buurt van het tuinhuisje.
- Draag een veiligheidsbril en volg altijd de instructies van de fabrikant als u elektrisch gereedschap gebruikt.
- Was het schuurtje met een tuinslang of een zacht schoonmaakmiddel. Gebruik geen harde borstel of schuurmiddelen, met inbegrip van ontvetters en schoonmaakmiddelen op basis van olie of aceton, omdat die het tuinhuisje kunnen beschadigen of vlekken achterlaten.
- Zet geen hete voorwerpen, zoals een pas gebruikte grill of branders in de schuur, en bewaar er ook geen vluchtige stoffen.
- Plaats geen zware voorwerpen tegen de wanden, die daardoor misvormd kunnen raken.
- Houd het dak vrij van opgehoopte sneeuw en bladeren. Grotere hoeveelheden sneeuw op het dak kunnen het schuurtje beschadigen, waardoor het betreden gevaarlijk kan zijn.
- De windrichting is een belangrijke factor bij het bepalen van de locatie van het tuinhuisje. Verminder blootstelling aan de wind, in het algemeen, en bijzonder aan de deurzijde. Houd de deuren gesloten en vergrendeld wanneer het tuinhuisje niet in gebruik is om windschade te voorkomen.
- Ga niet op het dak staan.
- Raadpleeg uw plaatselijke autoriteiten om te controleren of een vergunning vereist is voor het plaatsen van het tuinhuisje.

#### LINEE GUIDA PER LA CURA E LA SICUREZZA

- Il prodotto va utilizzato solo per scopi di immagazzinamento. Non è progettato per abitarvi.
- Si raccomanda vivamente di fissare il prodotto su un piano inamovibile o ancorandolo al suolo tramite i fori nel pavimento (nelle posizioni pre-segnalate) ed inserendo viti adeguate nel terreno (le viti non sono incluse).
- Non tentare il montaggio in giornate ventose o fredde.
- Controllate periodicamente il prodotto per accertarvi che sia stabile e che sia a livello del terreno.
- Fai attenzione quando maneggi parti con bordi in acciaio.
- Durante il montaggio o la manipolazione del prodotto, utilizzate solo gli strumenti elencati nel manuale utente.
- Indossare sempre guanti da lavoro, protezioni per gli occhi e maniche lunghe durante il montaggio o durante la manutenzione
- Evitate di utilizzare un tosaerba o una falce meccanica nei pressi del prodotto stesso.
- Indossate occhiali di sicurezza e seguite sempre le istruzioni del produttore quando utilizzate utensili elettrici.
- Lavate il prodotto con un tubo da giardino o una soluzione detergente delicata. Non utilizzate una spazzola dura o detersivi abrasivi, né sgrassanti e materiali di pulizia per l'olio - o a base di acetone, in quanto questi possono macchiarlo o danneggiarlo.
- Non conservate oggetti caldi, come grill e lampade per saldature né sostanze chimiche evaporabili all'interno del prodotto.
- Evitate di posizionare oggetti pesanti contro le pareti, in quanto ciò potrebbe causare una deformazione del prodotto.
- Mantenete il tetto pulito dalla neve e dalle foglie accumulate. Grandi quantità di neve sul tetto possono danneggiare il prodotto, rendendone precaria la struttura.
- La direzione del vento è un fattore importante da considerare quando scegliete la posizione del prodotto. Riducete l'esposizione al vento, in generale, in particolare della porta laterale. Tenete le porte chiuse e bloccate quando il prodotto non è in uso per prevenire i danni del vento.
- Non salite sul tetto.
- Consultate le autorità locali per verificare se sono necessari dei permessi per assemblare il prodotto.

#### DIRETRIZES SOBRE CUIDADOS E SEGURANÇA

- O abrigo destina-se apenas a fins de armazenamento. Não foi projetado para habitação.
- Recomenda-se vivamente a fixação do abrigo a um objeto imóvel ou fixá-lo no chão fazendo furos no piso do abrigo (nos locais previamente marcados) e a inserção de parafusos adequados no chão (os parafusos não estão incluídos).
- Não tente fazer a montagem em dias ventosos ou frios.
- Verifique periodicamente o abrigo para garantir que está estável e que o sítio está nivelado.
- Tenha cuidado ao manusear peças com pontas em aço.
- Ao montar ou manipular o abrigo, utilize apenas as ferramentas indicadas no manual do utilizador.
- Utilize sempre luvas e óculos de protecção, assim como vestuário comprido ao montar ou efectuar qualquer procedimento de manutenção no seu abrigo.
- Evite a utilização de um cortador de relva ou foice mecânica perto do abrigo.
- Use óculos de segurança e siga sempre as instruções do fabricante ao utilizar ferramentas elétricas.
- Lave o abrigo com uma mangueira de jardim ou uma solução de detergente suave. Não use uma escova rija ou detergentes abrasivos incluindo desengordurantes ou materiais de limpeza com base de óleo ou acetona, visto que estes podem manchar ou danificar o abrigo.
- Não guarde artigos quentes, como grelhas e maçaricos recentemente utilizados, e químicos voláteis no abrigo.
- Evite a colocação de artigos pesados contra as paredes, visto que isto pode causar distorção.
- Mantenha o telhado livre de acumulação de neve e folhas. Grandes quantidades de neve no telhado podem danificar o abrigo, tornando-o inseguro para entrar.
- A direcção do vento é um fator importante a ter em consideração ao determinar a localização do abrigo. Reduza a exposição ao vento, em geral, e em particular da porta lateral. Mantenha as portas fechadas e trancadas quando o abrigo não estiver a ser utilizado para evitar danos causados pelo vento.
- Não fique no telhado.
- Consulte as autoridades locais para saber se são necessárias licenças para erguer o abrigo.

#### LIMITED LIFETIME WARRANTY

Your Keter shed ("the Product") was manufactured from high-quality, recyclable materials under rigorous control and supervision.

Should a problem occur with the Product, please address your claim to Keter customer service on our website ([www.keter.com](http://www.keter.com)) or by phone.

This warranty covers product failure resulting from defects in manufacturing or materials for an unlimited period from the date of original retail purchase. (The term "defects" is defined as imperfections that impair the use of the Product).

In such case, consumer shall let Keter or anyone on its behalf inspect and/or test the alleged defective product at Keter laboratory or in any other place at Keter sole discretion.

This warranty does not cover defects resulting from normal wear and tear, including, but not limited to, scuffing, scratches or fractures caused during use, discoloration or fading, rusting, unreasonable use, abuse, negligence, alterations, painting, moving, transporting or relocating the Product, "acts of Nature," including, but not limited to, hail, any type of storm, flood and fire, and consequential or incidental damages.

Assembly and handling not in accordance with the recommendations, guidelines and restrictions as described in the Product's user manual, and usage for commercial or public applications, will void this warranty.

Keter is not responsible for any damage incurred by consumer and/or third parties or damage to or loss of objects inside or near the shed.

Upon submitting proof of purchase and evidence of the claimed product failure, and subject to reporting the failure in a timely manner, Keter, at its sole discretion, will replace defective parts of the Product, or refund you a prorated portion of the purchase price on a straight line depreciated basis, the value will depreciate 10% each year and remain at 10% for the length of the warranty.

#### GARANTIE ILLIMITÉE

Votre abri de jardin Keter (« le Produit ») a été fabriqué à partir de matériaux recyclables de grande qualité, en faisant l'objet de contrôles rigoureux et d'une surveillance stricte.

Si un problème devait se présenter avec le produit, veuillez adresser votre réclamation au service clients de Keter sur notre site internet ([www.keter.com](http://www.keter.com)) ou par téléphone.

Cette garantie couvre les dommages du produit découlant d'un défaut de fabrication ou des matériaux pour une durée illimitée à partir de la date d'achat. (Le terme « défaut » est défini comme des imperfections qui nuisent à la bonne utilisation du produit).

Dans ce cas, le consommateur autorise Keter ou quiconque agissant en son nom inspecter et/ou tester le produit présumé défectueux au laboratoire de Keter ou ailleurs, à la seule discrétion de Keter.

Cette garantie ne couvre pas les défauts résultant d'une usure normale, y compris, mais non limitée aux rayures, aux éraflures ou aux bris provoqués par l'utilisation, la décoloration ou l'estompement de la couleur, la rouille, l'utilisation déraisonnable, les abus, la négligence, les altérations, la peinture, les déplacements, le transport ou la relocalisation du produit, les « conditions climatiques exceptionnelles », y compris, mais non limitée à, la grêle, tout type de tempête, les inondations et incendies, et tous dégâts accidentels ou consécutifs qui y seraient liés.

Un assemblage et une manipulation non conformes aux recommandations, aux instructions et aux restrictions, telles que décrites dans le mode d'emploi du Produit, ainsi que l'utilisation à des fins commerciales ou publiques, annuleront cette garantie.

Keter ne saurait être tenu responsable de tout dégât encouru par le consommateur et/ou une tierce partie ou de tout dégât ou perte d'objets à l'intérieur ou à proximité de l'abri.

Après avoir fourni une preuve d'achat et une preuve du dommage sur le produit détérioré, et à condition d'avoir signalé le dommage dans les délais impartis, Keter, à son absolue discrétion, remplacera les pièces défectueuses du Produit ou vous remboursera une partie du prix d'achat au prorata, amorti sur une base linéaire. La valeur se dépréciera de 10% chaque année et sera maintenue à 10% de la valeur de la pièce défectueuse pour la durée de la garantie.

#### GARANTIA LIMITADA DE POR VIDA

Su caseta Keter ("El Producto") ha sido fabricada con materiales reciclables de alta calidad bajo rigurosos controles y supervisión.

En caso de que aparezca un problema con el Producto, por favor, dirija su reclamación al servicio al cliente de Keter en nuestra página web ([www.keter.com](http://www.keter.com)) o por teléfono.

Esta garantía cubre fallas de producto por defectos de fabricación o de materiales durante un período ilimitado desde la fecha de la compra del producto. (El término "defectos" se define como imperfecciones que afectan al uso del Producto).

En tal caso, el consumidor dejará que Keter o cualquier persona en su nombre inspeccionen o prueben el producto defectuoso alegado, en el laboratorio de Keter o en cualquier otro lugar a discreción única de Keter.

Esta garantía no cubre defectos resultantes por el desgaste debido al uso, incluyendo, entre otros, arañazos, rasguños o roturas provocados durante su uso, decoloración, oxidación, uso no razonable, maltrato, negligencia, alteraciones, pintado, mover, transportar o reubicar el Producto, "causas climatológicas", incluyendo, entre otros, granizo, cualquier tipo de tormenta, inundación e incendio y daños resultantes o accidentales.

El montaje y su manipulación sin seguir las recomendaciones, directrices y restricciones como se describen en el manual del usuario del Producto y su uso para aplicaciones comerciales o públicas anularán esta garantía.

Keter no se hace responsable por ningún daño realizado por consumidor o terceros o daños o pérdida de objetos dentro o cerca de la caseta.

Al entregar el ticket o factura de compra y prueba del presunto fallo del producto, y sujeto a informar del fallo de manera puntual, Keter, a su discreción, reemplazará las piezas defectuosas del Producto o le reembolsará una parte prorrateada proporcional del precio de compra en función, el valor se depreciará un 10% cada año y se mantendrá en el 10% de los años de garantía consumidos.

#### EINGESCHRÄNKTE LEBENSLANGE GARANTIE

Ihr Keter-Schuppen („the Product“) wurde unter genauer Kontrolle und strenger Aufsicht aus hochwertigen und recycelbaren Materialien hergestellt.

Falls Probleme am Produkt auftauchen sollten, adressieren Sie Ihre Ansprüche bitte an den Keter-Kundendienst auf unserer Webseite ([www.keter.com](http://www.keter.com)) oder wenden Sie sich per Telefon an uns.

Die Gewährleistung auf unbegrenzte Zeit umfasst Herstellungs- oder Materialdefekte am Produkt und gilt ab dem Datum des ursprünglichen Erwerbs. (Der Begriff „Defekte“ wird definiert als Beeinträchtigungen, die die Nutzung des Produktes herabsetzen).

Im gegebenen Fall erklärt sich der Verbraucher mit einer durch Keter bzw. durch eine im Auftrag von Keter handelnde Person durchgeführten Prüfung und/oder Untersuchung des mutmaßlich defekten Produkts in einem Keter-Labor oder - nach Keters alleinigem Ermessen - an einem anderen Ort einverstanden.

Diese Gewährleistung umfasst keine Defekte, die aus normalem Gebrauch resultieren und schließen unter anderem durch die Nutzung des Produktes entstandenen Abrieb, Kratzer oder Risse mit ein sowie Verfärbungen, Rostansatz und Schäden aufgrund von unsachgemäßer Nutzung, Missbrauch, Unachtsamkeit, Abänderungen, Bemalen, das Versetzen oder Transportieren des Produktes und „Naturereignisse“, wozu unter anderem Hagelschlag, jegliche Form von Sturm, Flut und Feuer zählen sowie mittelbare und damit verbundene Beschädigungen hierdurch.

Bei Aufbau und Handhabung, die nicht gemäß den Empfehlungen, Vorgaben und Beschränkungen durchgeführt werden, wie sie in der Gebrauchsanleitung zu dem Produkt vermerkt sind, verliert diese Gewährleistung ihre Gültigkeit. Dies gilt auch für einen Gebrauch zu kommerziellen und öffentlichen Zwecken.

Keter ist nicht verantwortlich für Beschädigungen durch Kunde und/oder Dritte und Schäden an und Verlust von Gegenständen innerhalb oder in der Nähe des Schuppens.

Nach der Einreichung von Kaufnachweis und Beweismaterial für den beanstandeten Defekt am Produkt, vorbehaltlich einer zeitnahen Meldung des Defekts, wird Keter während der gesamten Gewährleistungsdauer nach alleinigem Ermessen fehlerhafte Teile austauschen oder einen anteiligen Betrag des Kaufpreises auf Basis der linearen Abschreibung zurückerstatten, der Wert vermindert sich jährlich um 10% und verbleibt bei 10%.

#### BEPERKTE LEVENSLANGE GARANTIE

Uw Ketertuinhuysje ("het product") is vervaardigd uit hoogwaardige en recyclebare materialen, onder strenge controle en toezicht.

Mocht zich een probleem voordoen met het product, kunt u uw claim naar de klantenservice van Keter sturen via onze website ([www.keter.com](http://www.keter.com)) of per telefoon.

Deze garantie dekt het product voor gebreken in de productie of materialen voor een voor een onbeperkte periode vanaf de datum van de oorspronkelijke aankoop. (De term "gebreken" wordt gedefinieerd als onvolkomenheden die het gebruik van het product schaden).

In dat geval dient de consument het vermeende defecte product door Keter, of door wie dan ook in naam van Keter, te laten inspecteren en/of testen in een laboratorium van Keter, of op een andere plaats met goedkeuring van Keter.

Deze garantie geldt niet voor defecten die het gevolg zijn van normale slijtage, met inbegrip van, maar niet beperkt tot, schuren, krassen of breuken ontstaan tijdens het gebruik, verkleuring of vervaging van de kleuren, roest, onredelijk gebruik, misbruik, nalatigheid, wijzigingen, verven, vervoeren of verplaatsen van het product, "natuurlijke calamiteiten," met inbegrip van, maar niet beperkt tot, hagel, elke vorm van storm, overstroming en brand, en gevolg- of incidentele schade.

Bij assemblage en behandeling niet in overeenstemming met de aanbevelingen, richtlijnen en beperkingen zoals beschreven in de gebruiksaanwijzing van het product, en gebruik voor commerciële of publieke toepassingen, vervalt deze garantie.

Keter is niet verantwoordelijk voor enige schade opgelopen door consument en/of derden of schade aan of verlies van objecten binnen of in de buurt van het tuinhuysje.

Door het indienen van het aankoopbewijs en het bewijs van het geclaimde gebrek aan het product, en onder voorbehoud van een tijdige rapportage van de gebreken, zal Keter, naar eigen goedkeuren, defecte onderdelen van het product vervangen of een (naar rato) deel van de koopprijs terugbetalen op basis van een lineair afgeschreven bedrag, de waarde zal elk jaar met 10% verminderen en vervolgens op 10% gehandhaafd blijven, de duur van de garantie.

#### GARANZIA LIMITATA A VITA

Il tuo capannone Keter ("il Prodotto") è stato fabbricato con materiali riciclabili di alta qualità sotto un controllo ed una supervisione rigorosi.

In caso di problemi con il prodotto, cortesemente rivolgetevi al servizio clienti Keter sul nostro sito web ([www.keter.com](http://www.keter.com)) o per telefono.

Questa garanzia copre il guasto del prodotto dovuto a difetti di fabbricazione o dei materiali per un tempo illimitato dalla data di acquisto originale. (Il termine "difetti" è definito come imperfezioni che compromettono l'uso del prodotto).

In tal caso, il consumatore dovrebbe permettere a Keter o a qualche suo rappresentante di ispezionare e/o testare il prodotto presumibilmente difettoso presso un laboratorio Keter o qualsiasi altro laboratorio che Keter sceglierà a sua esclusiva discrezione.

Questa garanzia non copre i difetti derivanti da normale usura, inclusi, ma non limitati a, sfregamento, graffi o fratture createsi durante l'uso, scolorimento, ruggine, uso irragionevole, abuso, negligenza, alterazione, pittura, movimento, trasporto o spostamento del prodotto, "eventi naturali", tra cui, ma non limitati a, grandine, qualsiasi tipo di tempeste, inondazioni e incendi e danni conseguenti o accidentali.

L'assemblaggio e la manipolazione non in conformità con le raccomandazioni, le linee guida e le restrizioni descritte nel manuale utente del prodotto ed il loro utilizzo per applicazioni commerciali o pubbliche renderà nulla questa garanzia.

Keter non è responsabile per eventuali danni subiti da consumatore e/o terzi o per danni o smarrimenti di oggetti all'interno o nei pressi del capannone.

Dopo aver inviato la prova di acquisto e la prova del problema del prodotto, soggetto a dichiarazione tempestiva del problem, Keter, a sua esclusiva discrezione, sostituirà le parti difettose del prodotto, o rimborserà una parte proporzionale del prezzo di acquisto su una linea retta basata sull'ammortamento, il valore si deprezzerà del 10% ogni anno e rimarrà al 10% per la durata della garanzia.

#### GARANTIA VITALÍCIA LIMITADA

O seu abrigo Keter ("o Produto") foi fabricado manualmente a partir de materiais recicláveis de qualidade superior sob controlo e supervisão rigorosos.

Em caso de ocorrência de algum problema com o Produto, por favor, faça a sua reclamação para o serviço de apoio ao cliente Keter no nosso site ([www.keter.com](http://www.keter.com)) ou por telefone.

Esta garantia cobre falhas do produto resultantes de defeitos de fabrico ou materiais por tempo ilimitado a partir da data da compra a retalho original. (O termo "defeitos" é definido como imperfeições que comprometam a utilização do Produto).

Nesse caso, o consumidor deverá permitir à Keter ou ao seu representante inspecionar e/ou testar o produto com o defeito alegado no laboratório da Keter ou em qualquer outro local a critério da Keter.

Esta garantia não cobre defeitos resultantes da utilização e desgaste normais, incluindo, mas não limitado a, fricção, arranhões ou fraturas causadas durante a utilização, descoloração ou desbotamento, oxidação, utilização pouco razoável, abuso, negligência, modificações, pintura, deslocação, transporte ou reposicionamento do Produto, "atos da Natureza", incluindo, mas não limitado a, granizo, qualquer género de tempestade, inundação e incêndio, e danos consequentes ou acidentais.

A montagem e manipulação que não estejam em conformidade com as recomendações, diretrizes e restrições de acordo com o descrito no manual do utilizador do Produto, e a utilização para a finalidades comerciais ou públicas, anularão esta garantia.

A Keter não se responsabiliza por quaisquer danos incorridos por consumidor e/ou terceiros ou danos e perdas dentro ou perto do barracão.

Mediante a apresentação do comprovativo de compra e prova da falha do produto reclamado, e sujeito a reportar a falha do produto atempadamente, a Keter, ao seu critério exclusivo, irá proceder à substituição das partes defeituosas do Produto, ou reembolsá-lo com uma parcela proporcional ao preço de compra numa base de amortização linear relativa o valor será depreciado em 10% ao ano e permanecerá em 10% à duração da garantia.

Made in Israel by | Fabriqué en Israël par | Fabricado en Israel por | Hergestellt in Israel von | Gemaakt in Israël door |  
Realizzato in Israele da | Fabricado em Israel por  
Keter Plastic Ltd., 2 Sapir St. Industrial Area, Herzliya 46852, Israel



For assistance with assembly, or to request replacement parts, log onto our website or call Customer Service.

**DO NOT RETURN THE PRODUCT TO THE STORE.**

Si vous avez besoin d'aide pour le montage, ou pour demander des pièces de rechange, connectez-vous sur notre site Web ou appelez le service à la clientèle.

**NE RETOURNEZ PAS LE PRODUIT AU MAGASIN.**

Para obtener ayuda sobre el montaje o para solicitar piezas de repuesto, conéctese a nuestra página web o llame a Atención al cliente.

**NO DEVUELVA EL PRODUCTO A LA TIENDA.**

Wenn Sie Hilfe beim Aufbau oder Ersatzteile benötigen, melden Sie sich auf unserer Webseite an oder rufen Sie unseren Kundenservice an.

**GEBEN SIE DAS PRODUKT NICHT IM GESCHÄFT ZURÜCK.**

Als u hulp nodig heeft bij de montage of vervangende onderdelen wilt bestellen, kunt u inloggen op onze website of bellen met de klantenservice.

**BRENG HET PRODUCT NIET TERUG NAAR DE WINKEL.**

Per assistenza al montaggio, o per richiedere pezzi di ricambio, accedi al nostro sito o chiama il servizio clienti.

**NON RESTITUIRE IL PRODOTTO AL NEGOZIO.**

Para obter ajuda na montagem, ou para solicitar peças de substituição, inicie a sessão no nosso sítio da Internet ou ligue para o Serviço de Apoio ao Cliente.

**NÃO DEVOLVA O PRODUTO À LOJA.**

US, Canada:  
6435 South Scatterfield Road,  
Anderson, Indiana 46013, USA  
Tel: +1-877-638-7056  
Fax: +1-704-263-9271

UK:  
2nd Floor, WESTPOINT, Mucklow  
Office Park, Halesowen, West  
Midlands, B62 8DY, United Kingdom  
Tel: 0121-506-0008  
Fax: 0121-422-0808

Spain:  
Avenida Conde de Romanones 6-b.  
Polg. Ind. Miralcampo, 19200 Azuqueca  
de Henares - Guadalajara, Spain  
Tlf. +34-976-460-006  
Fax +34-976-460-281

Other European Countries:  
Ericssonstraat 17, Postbus 224,  
5120 AE Rijen, the Netherlands  
Tel: 31-8847-22277,  
Fax: 31-1612-27002