

## 75050

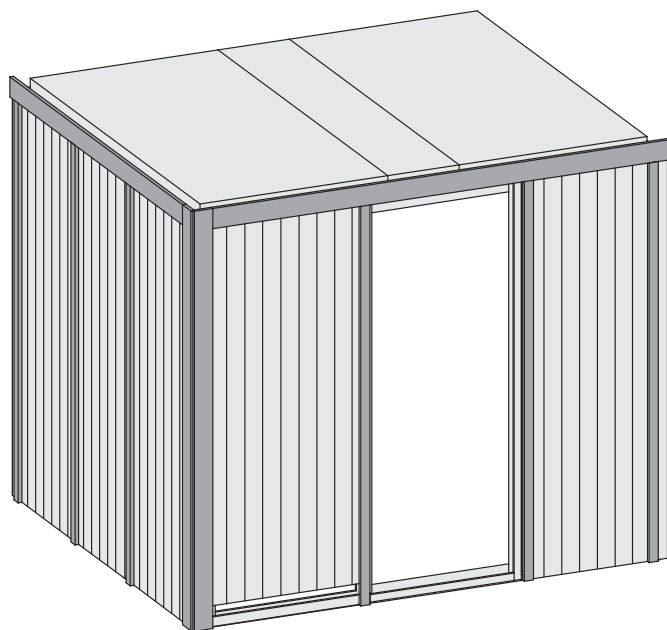

-  **Aufbauanleitung**
-  **Building Instructions**
-  **notice de montage**
-  **montagehandleiding**
-  **Montagevejledning**
-  **Instrucciones de construcción**
-  **Istruzioni per il montaggio**
-  **Montážní návod**

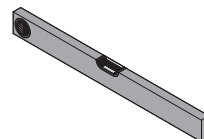

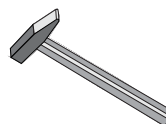

Vergleichen Sie zuerst die Material-liste mit Ihrem Paketinhalt! Bitte haben Sie Verständnis, dass Beanstandungen nur im nicht aufgebauten Zustand bearbeitet werden können!



Vergelijk eerst de lijst van materialen met de inhoud van uw pakket! Reclamaties kunnen alleen in behandeling worden genomen zolang de onderdelen nog niet zijn gemonteerd!



Confrontate questa distinta materiali prima con il contenuto del pacchetto! Vi preghiamo di comprendere che eventuali reclami possono essere accolti solo prima del montaggio!



First compare the list of materials with your package contents! Please understand that complaints can be processed in the non-built status only!



Start med at kontrollere materialelisten med indholdet af den leverede pakke! Vi gør venligst opmærksom på at reklamationer kun kan behandles for materialer som ikke er blevet bearbejdet!



Nejprve přezkontrolujte obsah balení podle materiálového listu! Mějte pochopení pro to, že případnou reklamaci se můžeme zabývat pouze tehdy, když díly nebudou smontované! Za pomoci tohoto seznamu můžete jednotlivé díly přiřadit k montážnímu návodu.



Commencez par comparer la liste du matériel avec le contenu de votre paquet! Sachez que nous traitons uniquement les réclamations concernant le matériel à l'état non monté!



En primer lugar, compare la lista de material con el contenido del paquete. Rogamos entienda que las reclamaciones sólo pueden ser tramitadas antes de montar el objeto!

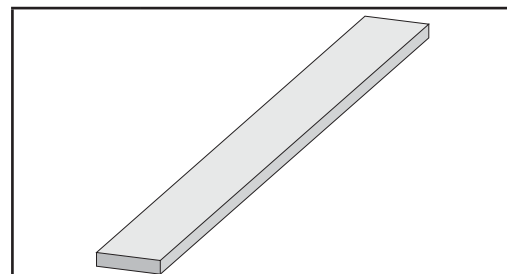
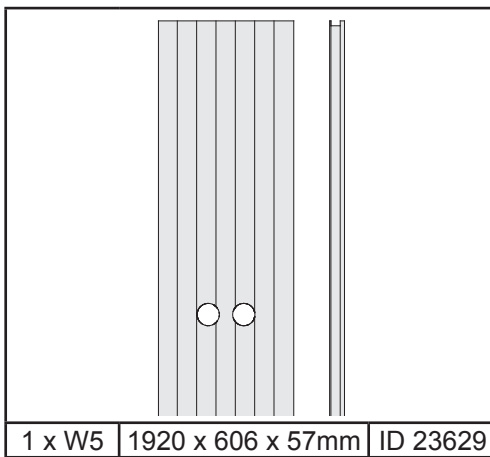
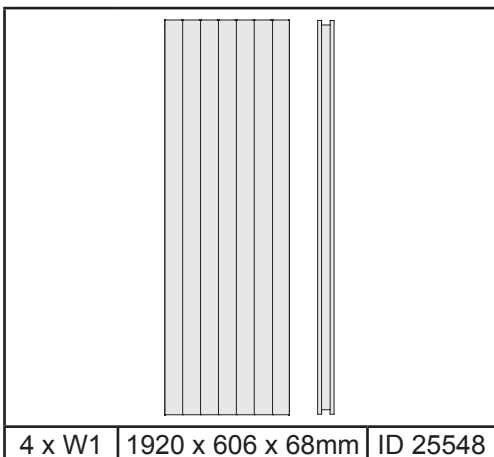
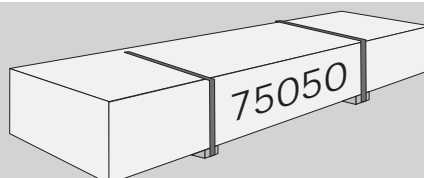

9 x B1	1920 x 19 x 3mm	ID 20799
4 x B2	750 x 36 x 12mm	ID 24239
4 x B3	1920 x 36 x 12mm	ID 24846
6 x B4	1884 x 45 x 17mm	ID 48037
4 x B5	70 x 45 x 18mm	ID 26366
4 x B6	800 x 45 x 18mm	ID 24796
4 x B7	480 x 95 x 18mm	ID 20930
4 x B8	580 x 95 x 18mm	ID 16708
2 x B9	2245 x 95 x 18mm	ID 26369
1 x B10	300 x 120 x 18mm	ID 22467
1 x B11	540 x 42 x 28mm	ID 26359
2 x B12	590 x 42 x 28mm	ID 26360
2 x B13	1130 x 42 x 28mm	ID 26361
2 x B14	1812 x 42 x 28mm	ID 24123
4 x B15	1922 x 42 x 28mm	ID 26384
2 x B16	2105 x 42 x 28mm	ID 24125
4 x B17	2187 x 42 x 28mm	ID 24534
3 x B18	1874 x 52 x 52mm	ID 26165

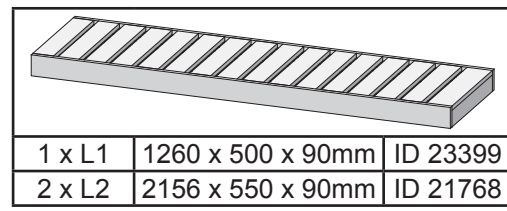
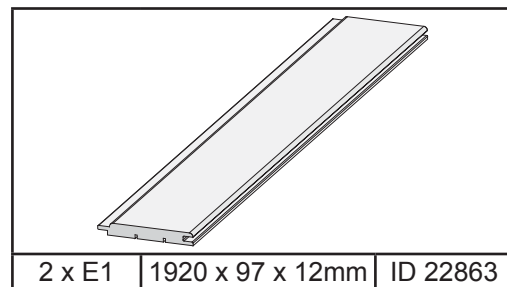
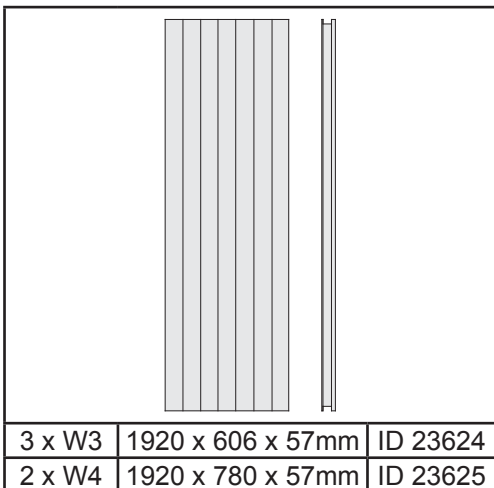
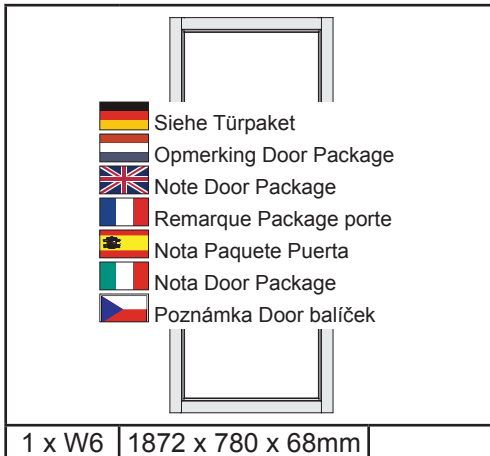
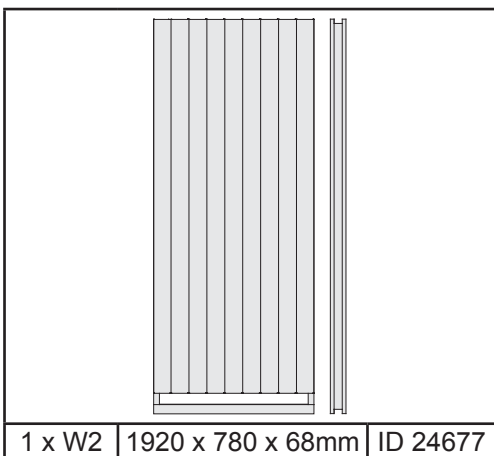

1 x F1	1260 x 90 x 22mm	ID 56629
1 x F2	1656 x 90 x 22mm	ID 56638
1 x F3	2156 x 90 x 22mm	ID 26390

10m		ID 14025
-----	--	----------

5 x	3 x 16mm	ID 46376

190 x	4 x 30mm	ID 3686
30 x	4 x 40mm	ID 21925
80 x	4 x 50mm	ID 3688
50 x	4 x 70mm	ID 3689
80 x	4,5 x 80mm	ID 9204
40 x	6 x 60mm	ID 14014

2 x G1	1980 x 95 x 17mm	ID 48540

1 x		ID 50420

20 x	4,5 x 30mm	ID 26115
120 x	4,5 x 40mm	ID 26285

1 x K1	1874 x 64 x 64mm	ID 24725

<p>Modell:</p> <p> <b>Brandgefahr!</b> Das Abhängen von Gegenständen oder Textilien auf dem Saunaofen oder dessen Abschrankungen ist verboten. Be- und Entlüftungsräume dürfen nicht verschlossen werden.</p> <p><b>Anleitung beachten!</b></p> <p><input type="checkbox"/> 3,6 kW   <input type="checkbox"/> 5kWPE - 230 V   <input type="checkbox"/> Integrierte Steuerung   <input type="checkbox"/> Bio  <input type="checkbox"/> 4,5 kW   <input type="checkbox"/> 5kWPE - 400 V   <input type="checkbox"/> Externe Steuerung   <input type="checkbox"/> Finnisch</p> <p><small>Kaldera Heiztechnik GmbH • Eduard-Saling-Str. 17 • 26217 Bremen</small></p>		
1 x		

6 x S1		ID 14266
--------	--	----------

3 x S2		ID 42172
--------	--	----------

150 x S3	4,5 x 30mm	ID 26116
16 x S4	12 x 18mm	ID 46403

1 x M1	1839 x 349 x 57mm	ID 24799
2 x M2	1839 x 918 x 57mm	ID 45230

4 x T1		ID 26272
--------	--	----------

20 x		ID 14005
------	--	----------

2 x		ID 21292
-----	--	----------

1 x		ID 20708
-----	--	----------

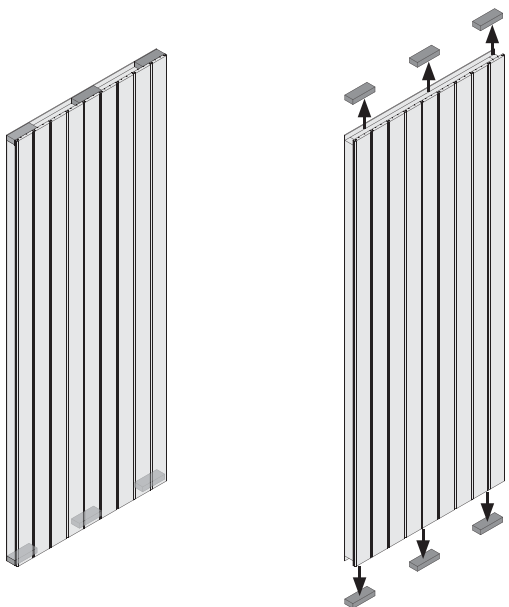

- 
- Vorsicht!**
  - Attention!**
  - Attention!**
  - Voorzichtig!**
  - Forsigtig!**
  - Cuidado!**
  - Occhio!**
  - Pozor!**

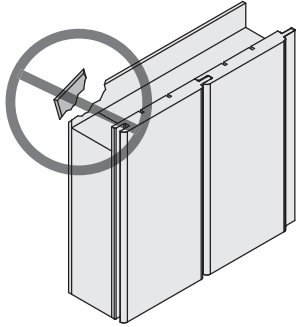

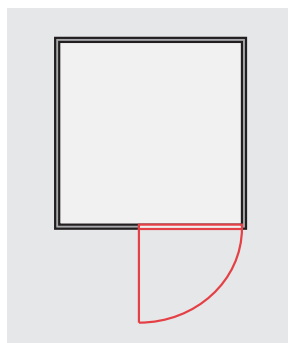
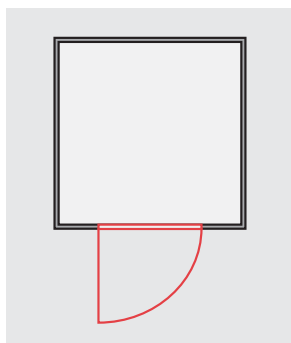
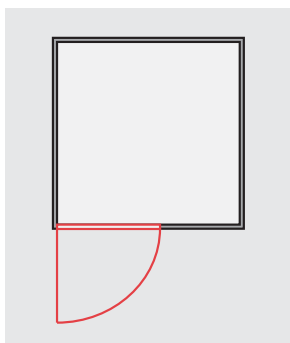
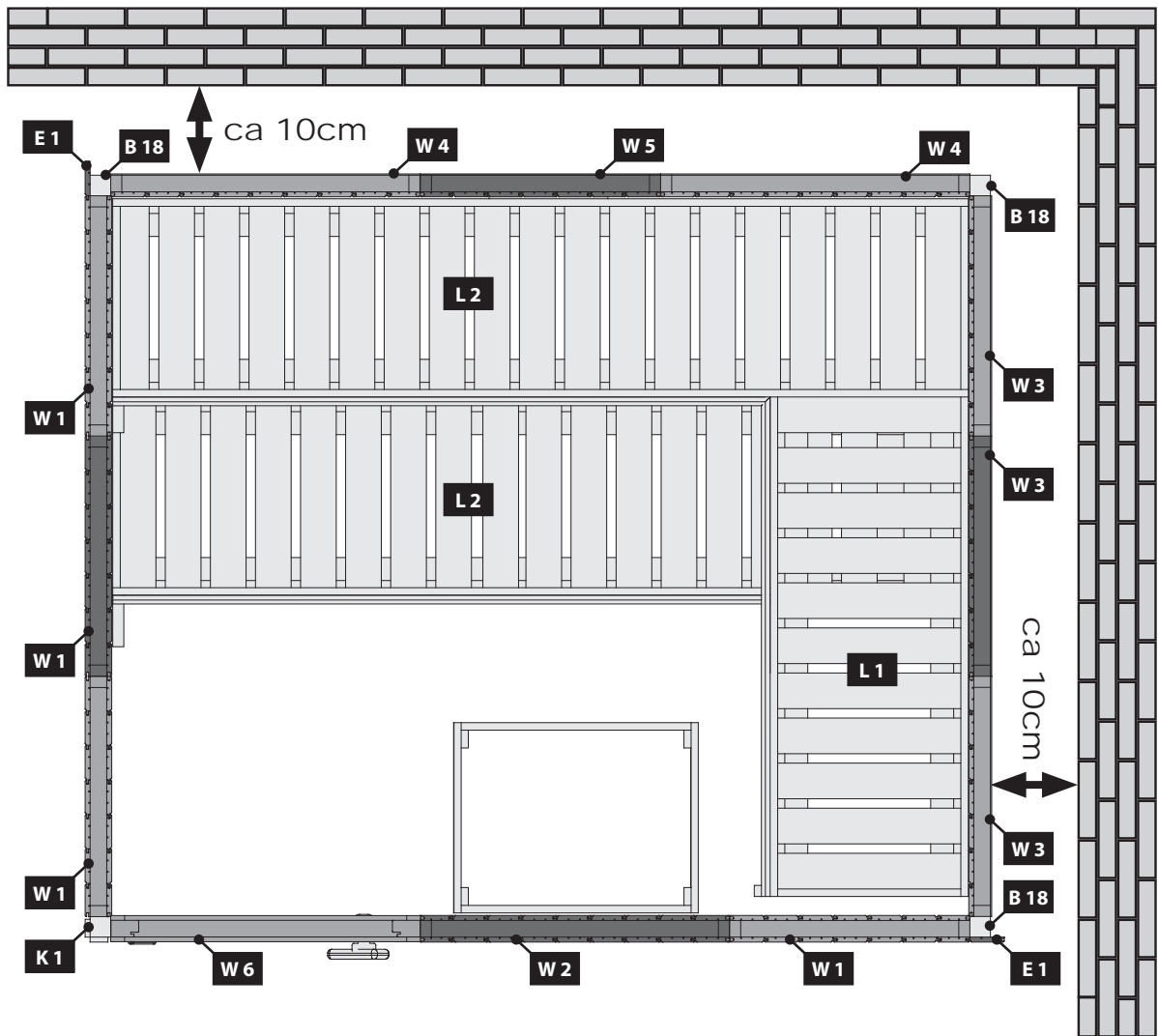

-  Einbau Tür
-  Installation door
-  Porte d'installation
-  Installatie deur
-  Installationsdør
-  Puerta de instalación
-  Porta di installazione
-  Montážní dveře

01 2x

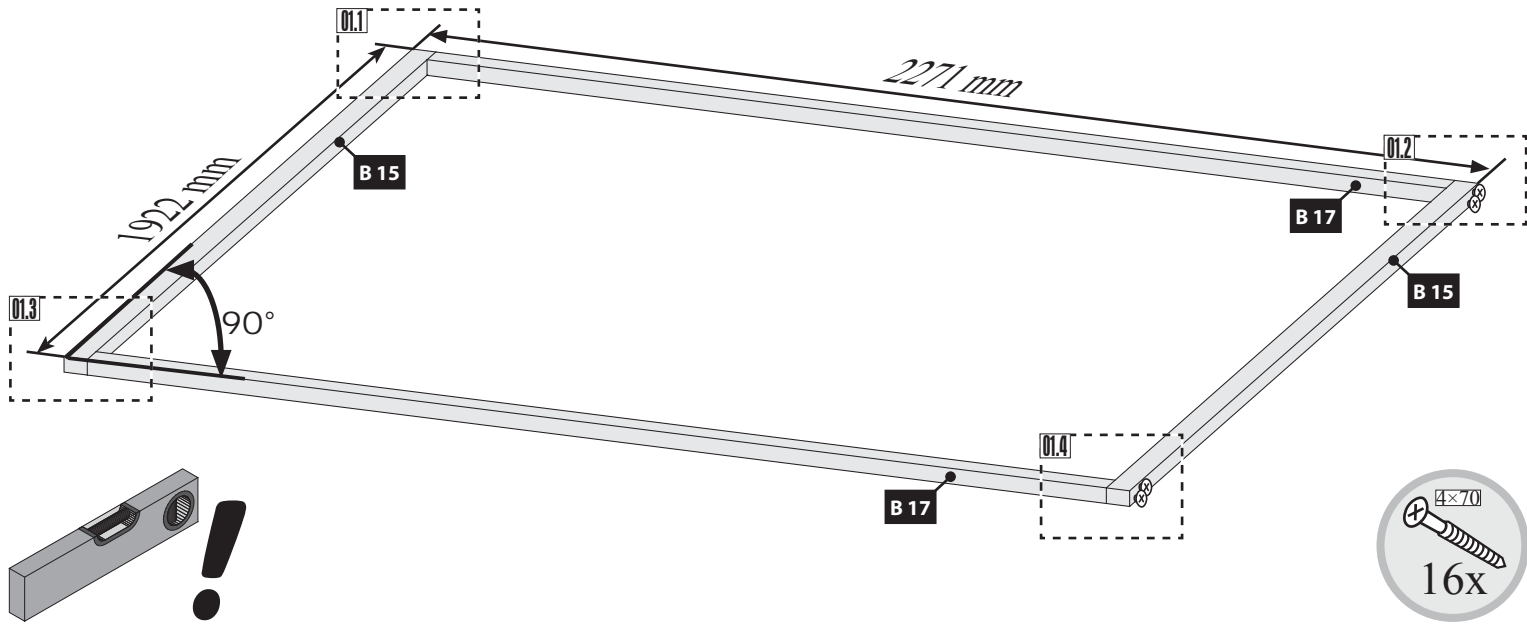

01.1

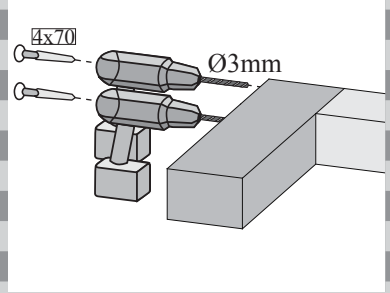

01.2

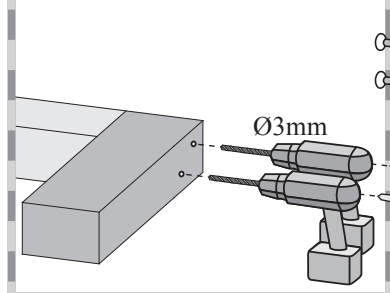

01.3

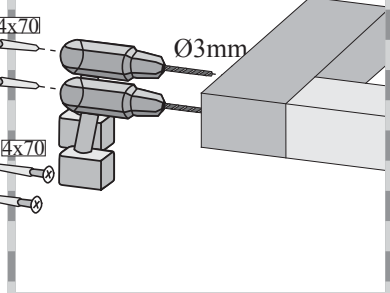

01.4

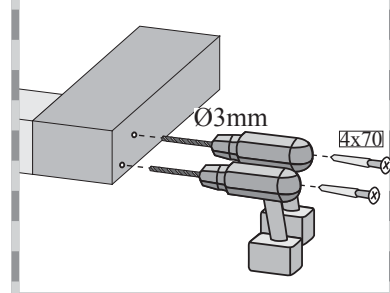

02

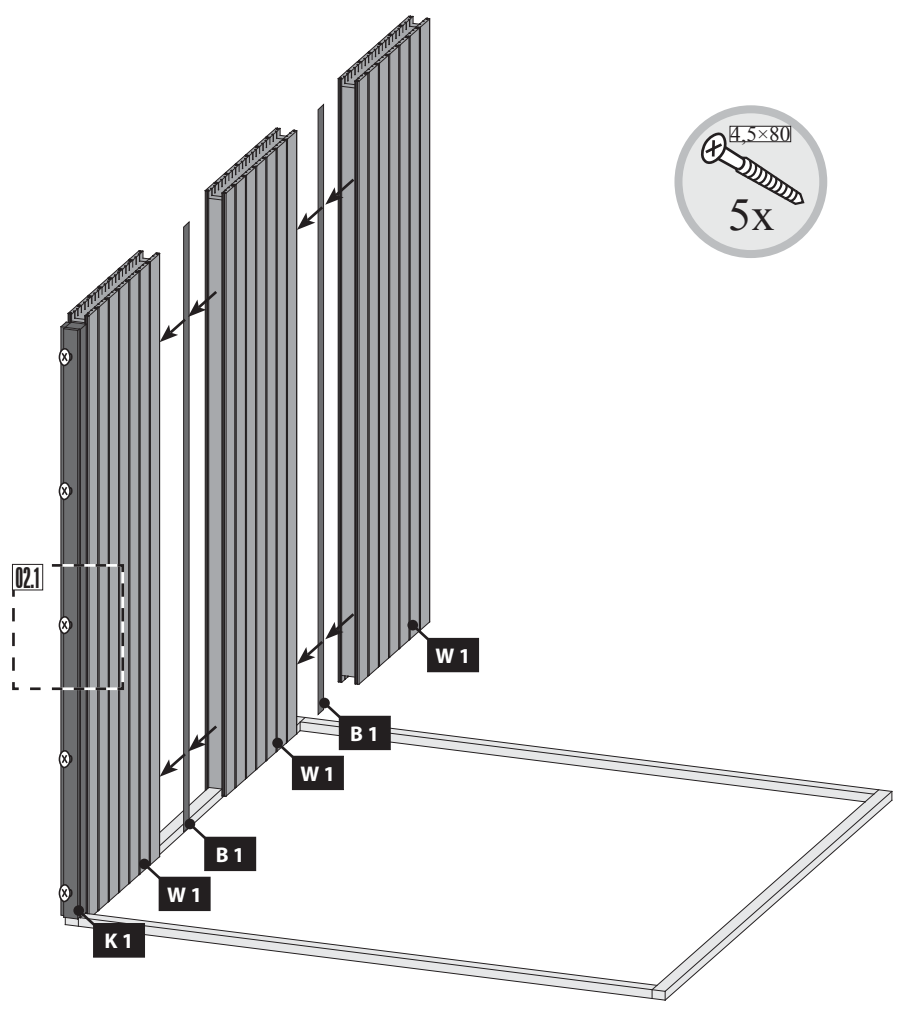

02.1

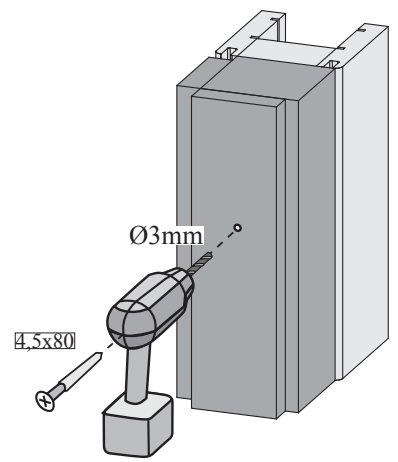

03

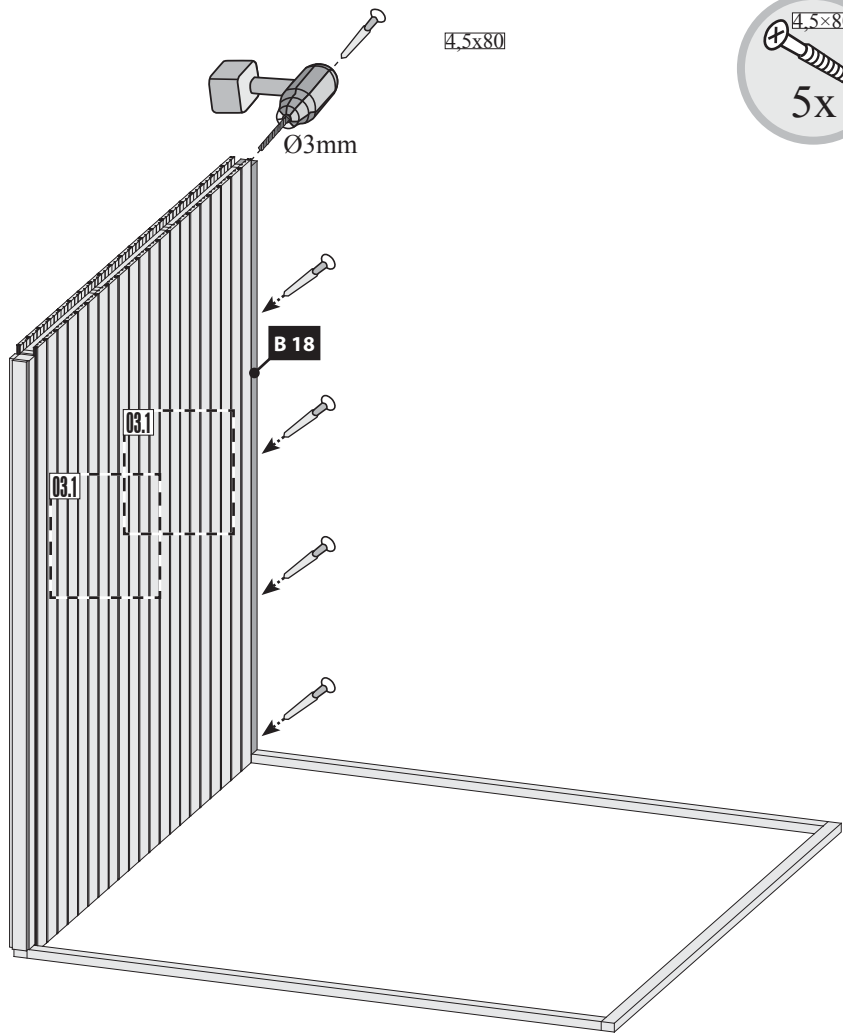

03.1

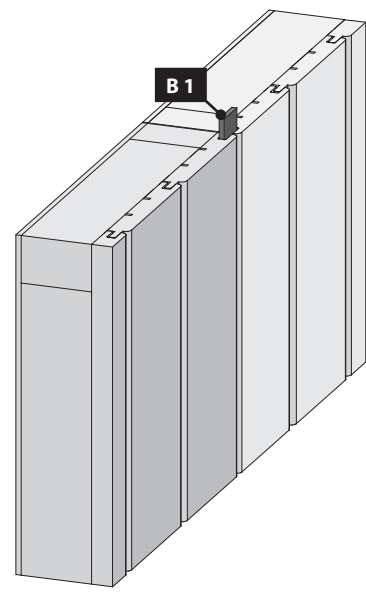

04

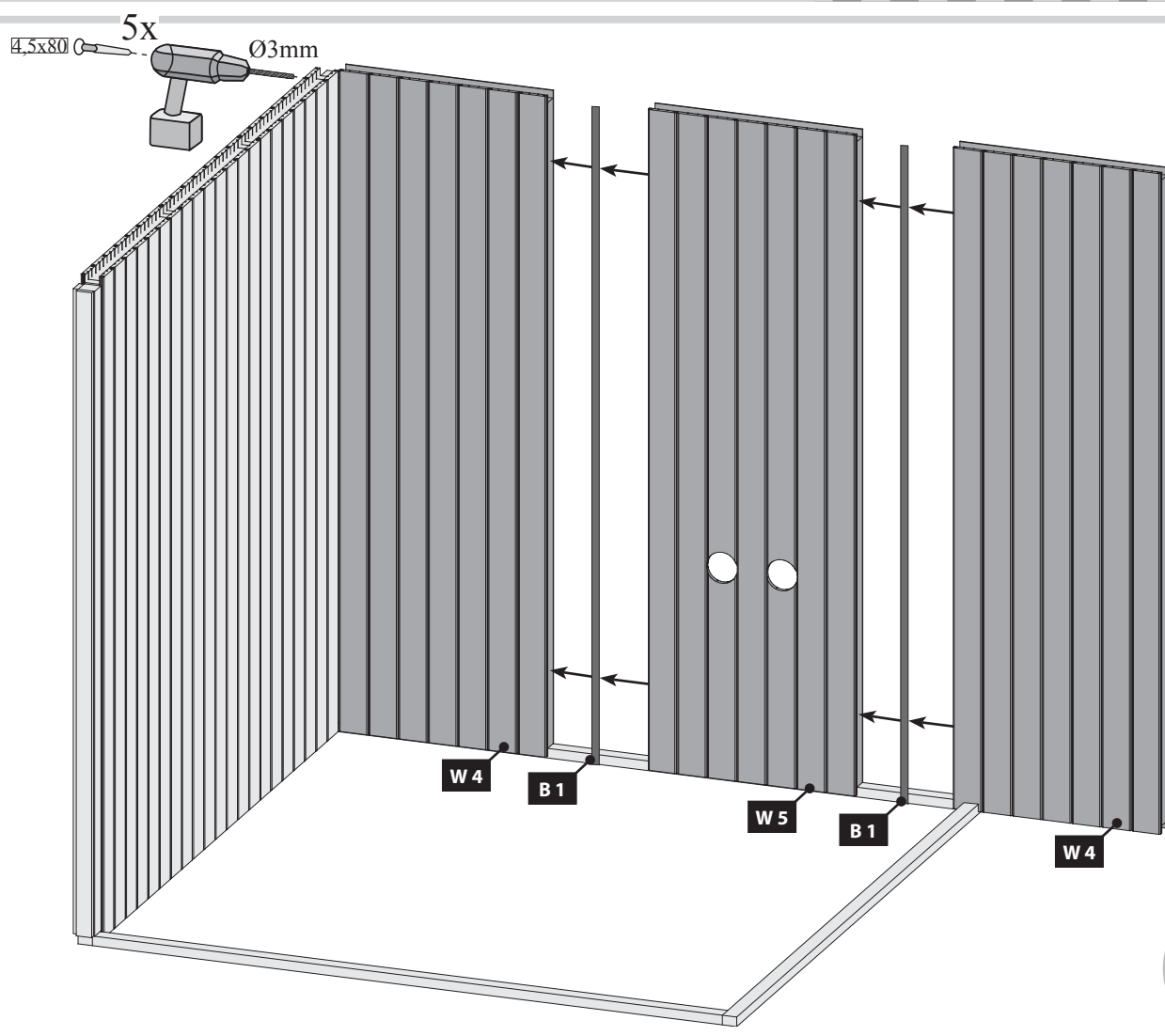

05

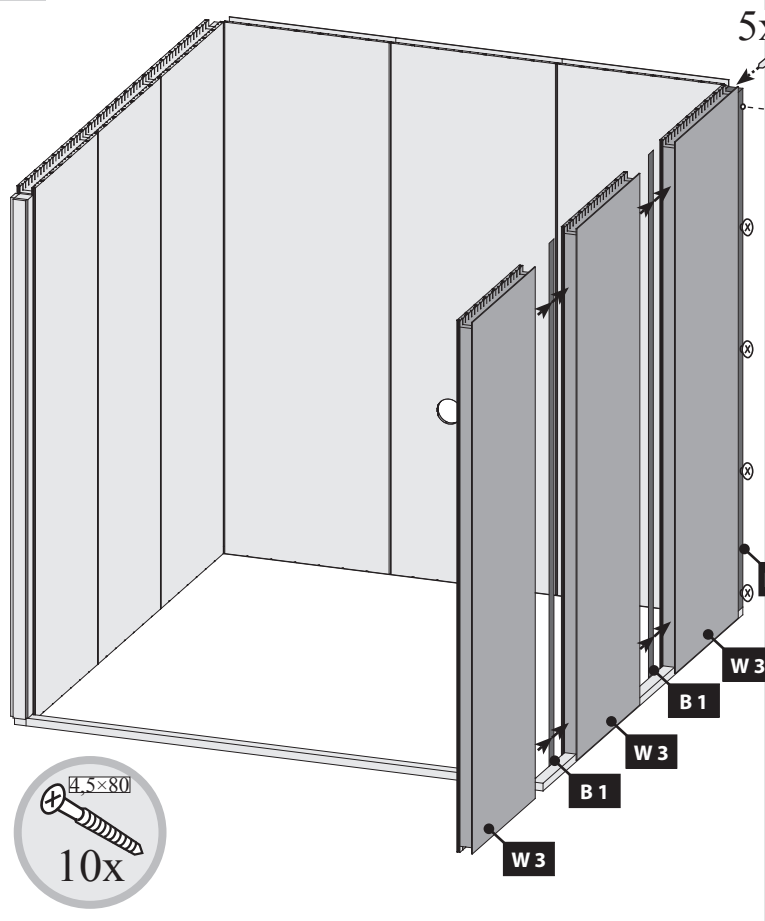

06

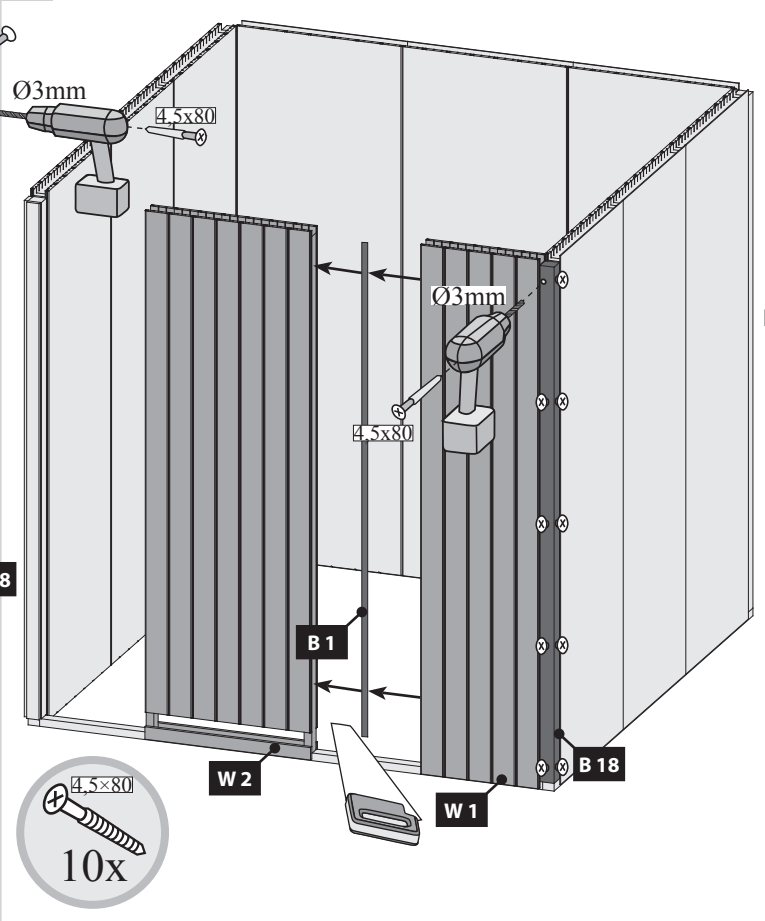

07

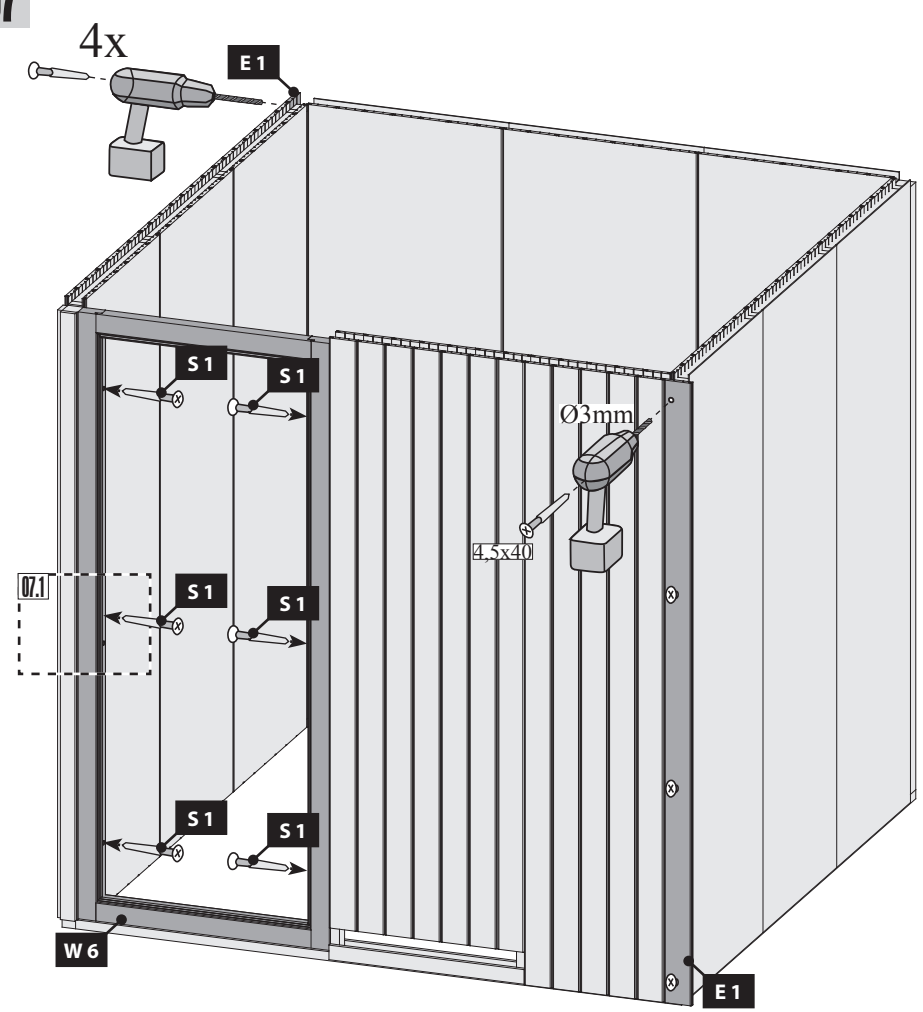

07.1-1

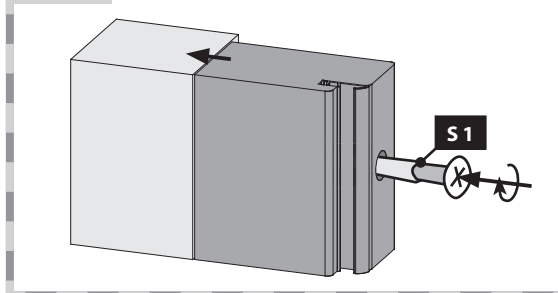

07.1-2

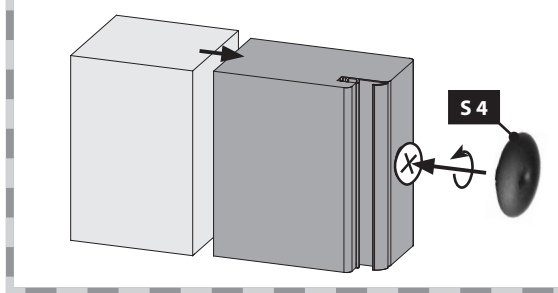

Einbau Saunatür  
 Installation de porte Sauna  
 Sauna door installation  
 Sauna deur installatie  
 Instalación de la puerta Sauna  
 Installazione porta Sauna  
 Sauna Instalace dveře

**STOP**

**!!! 01 — 03 !!!**

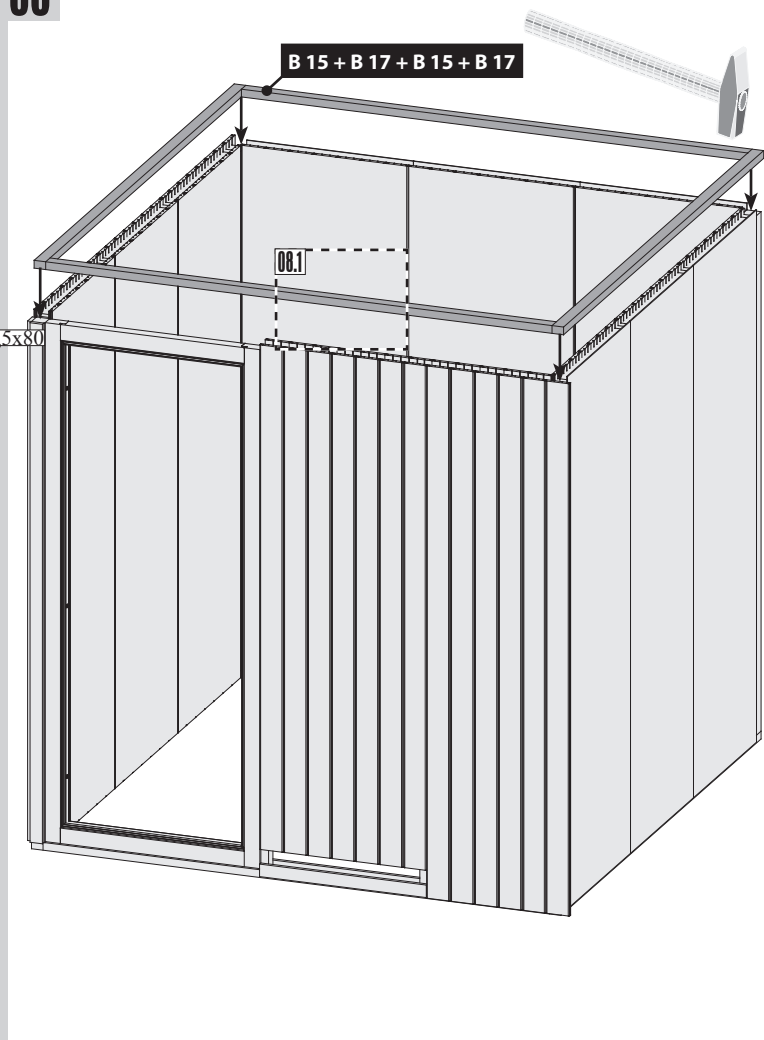
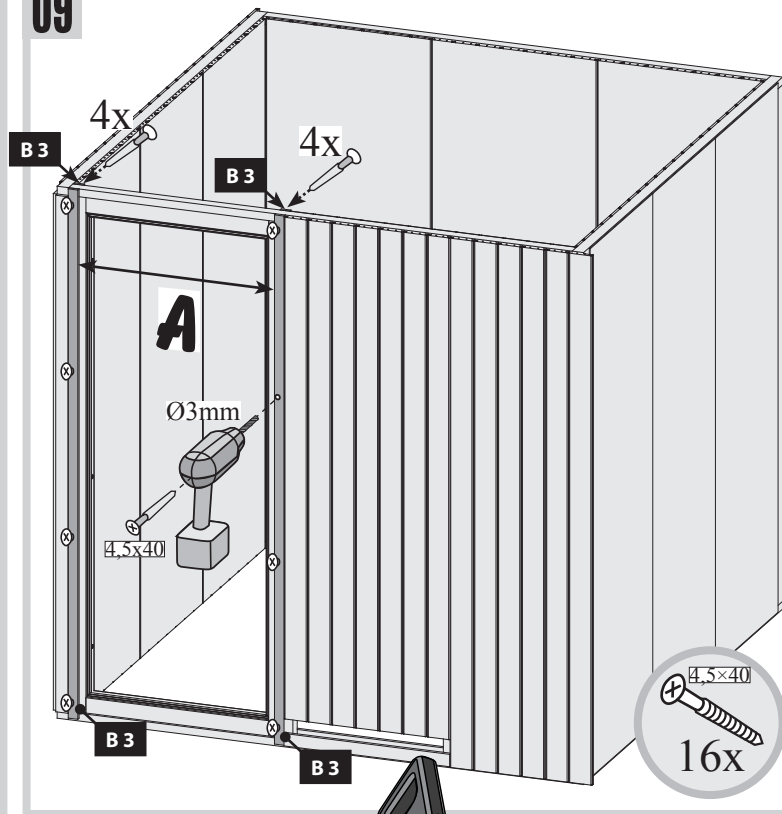
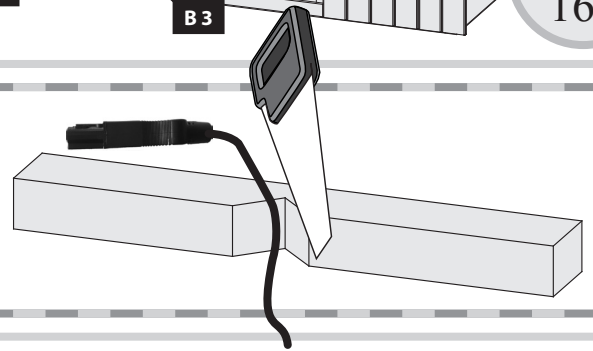
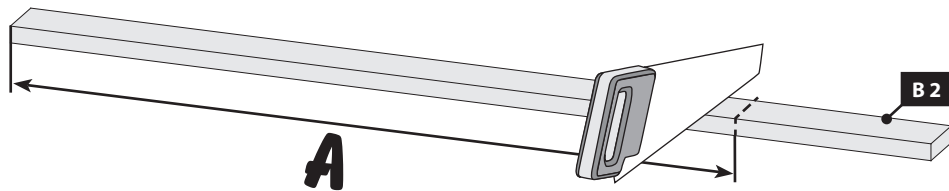
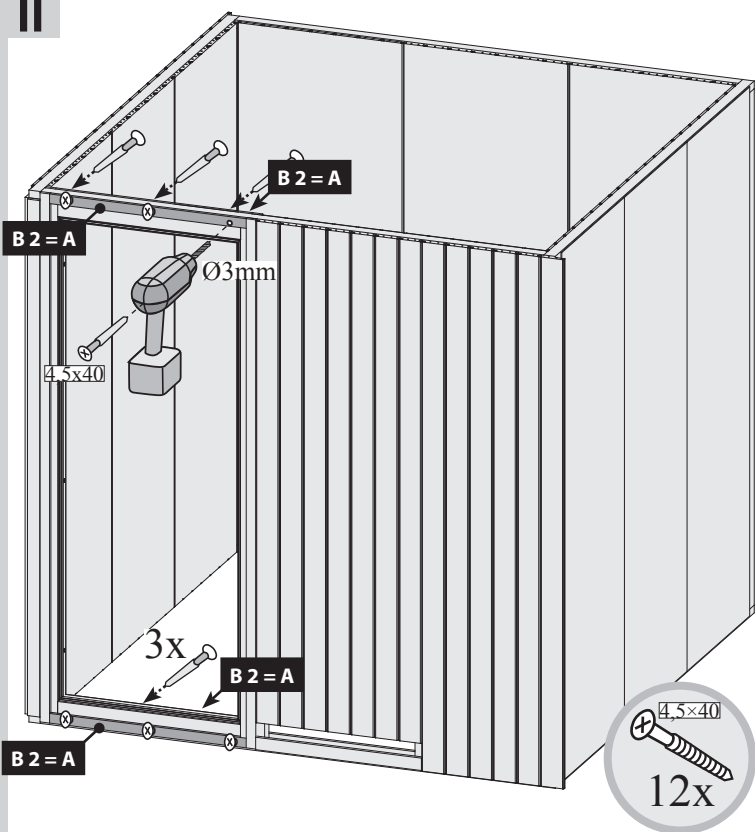
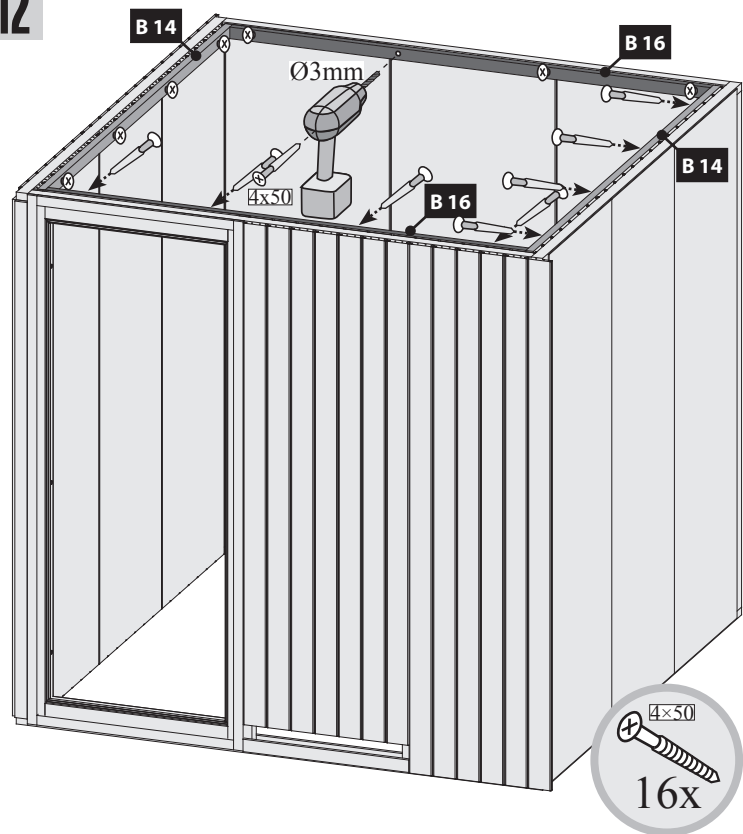
**08****09****08.1****10****4x****11****12**



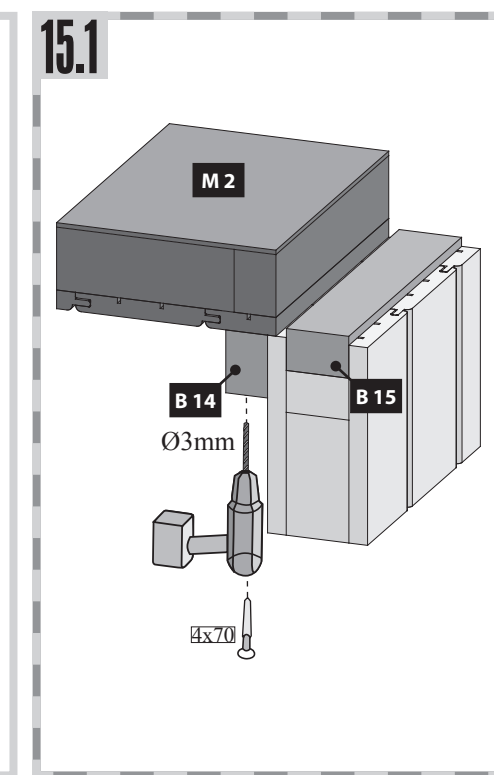
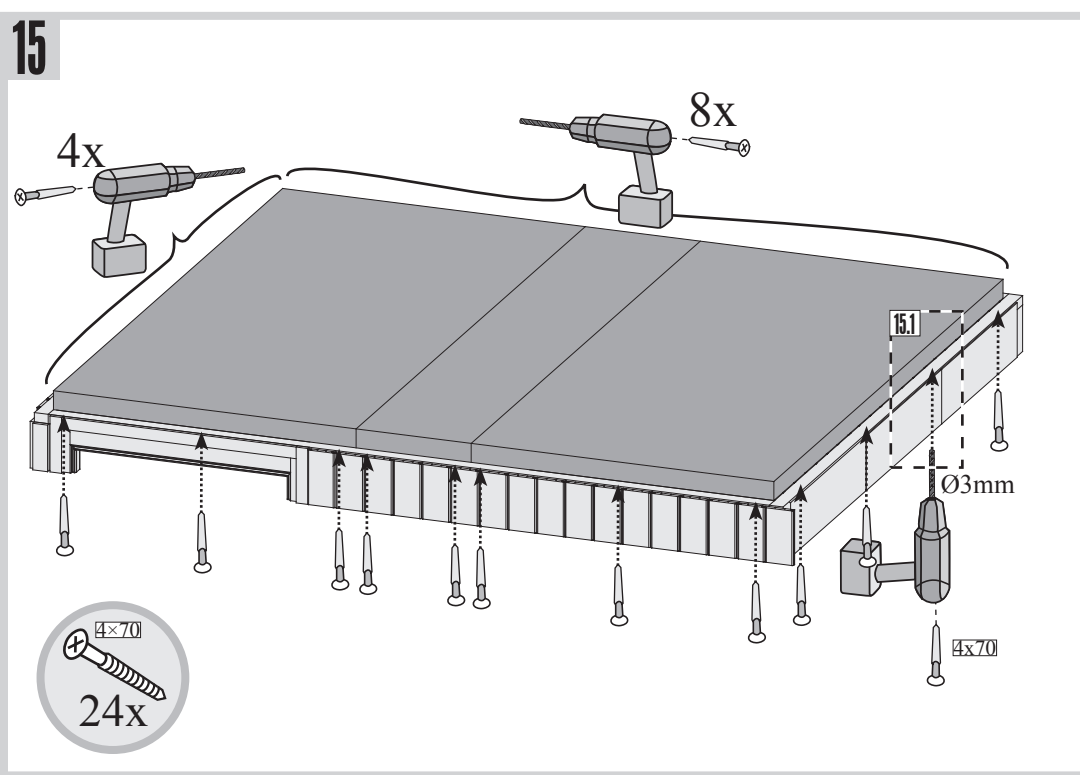
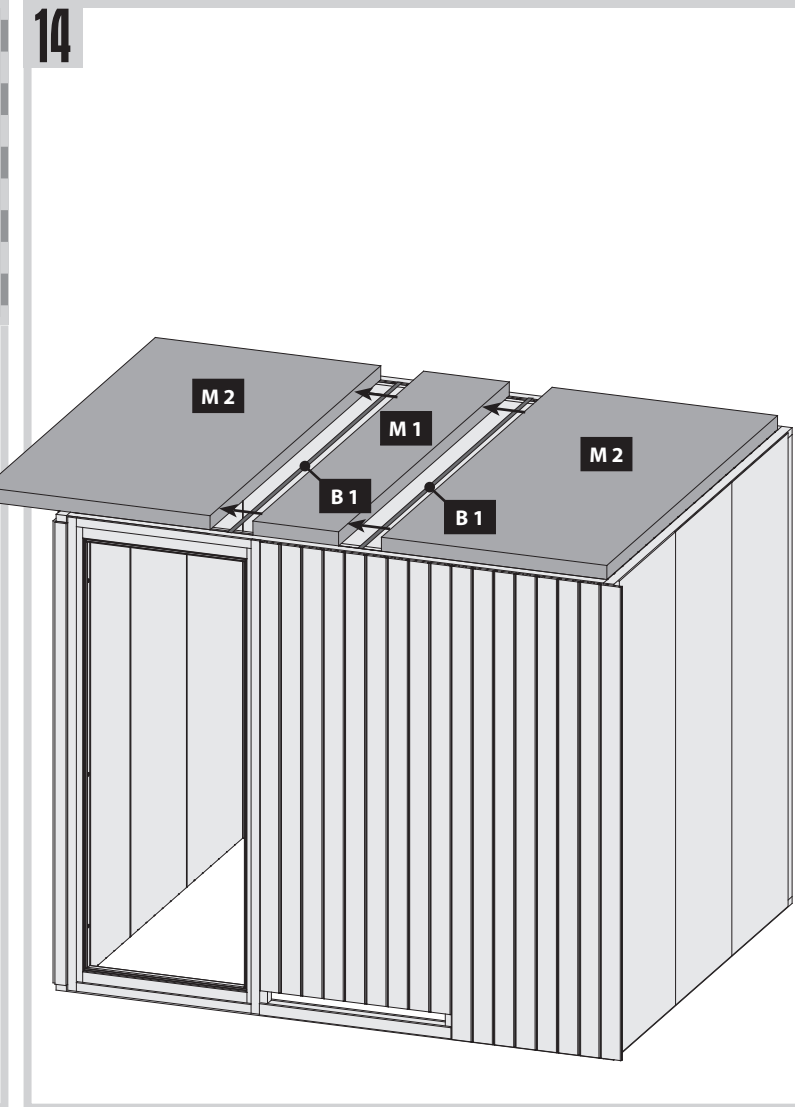
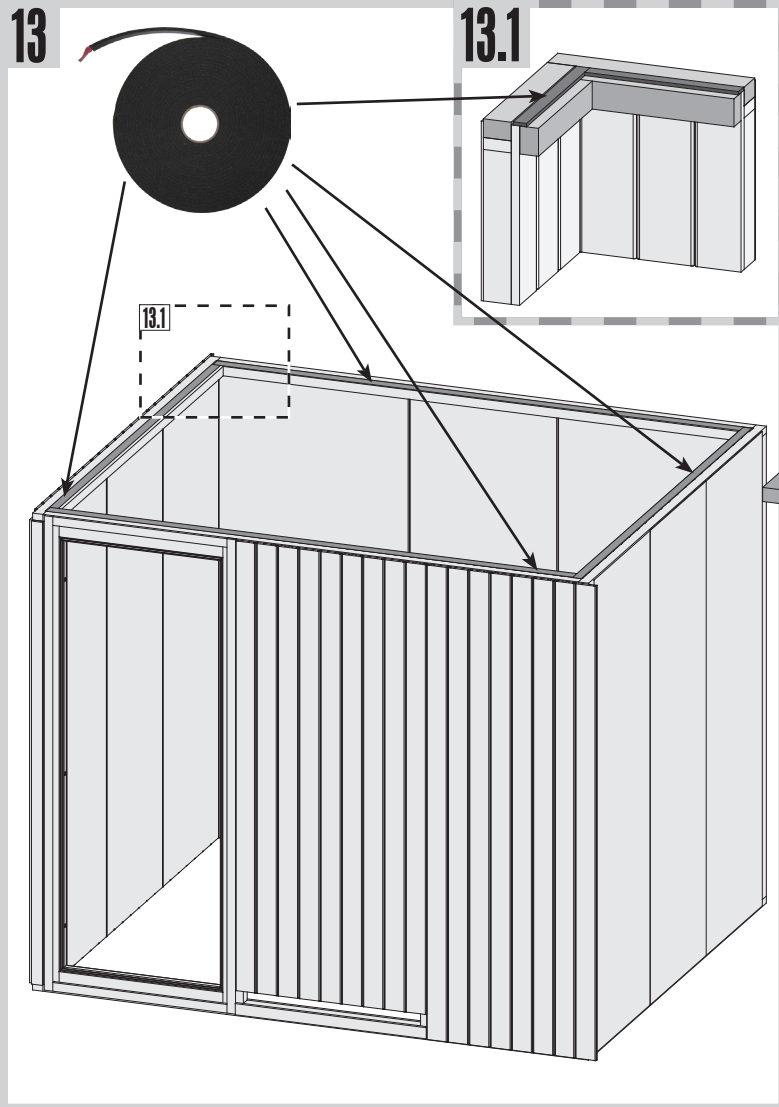

16

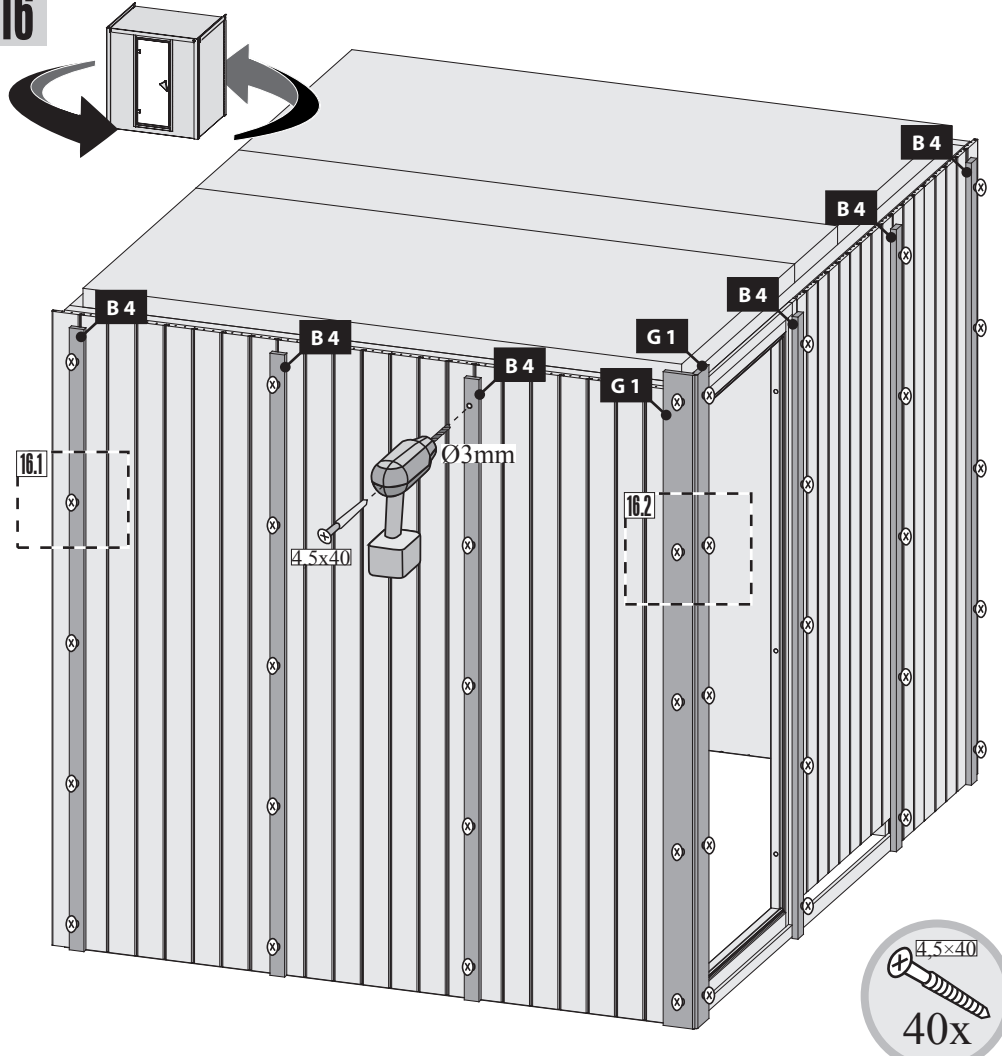

16.1

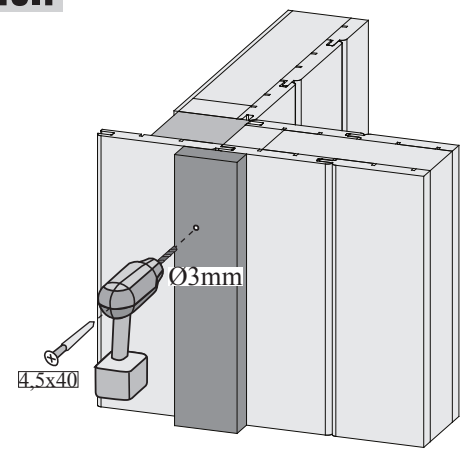

16.2

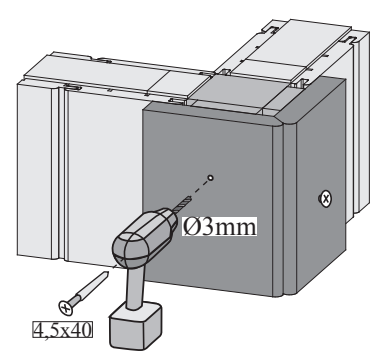

17

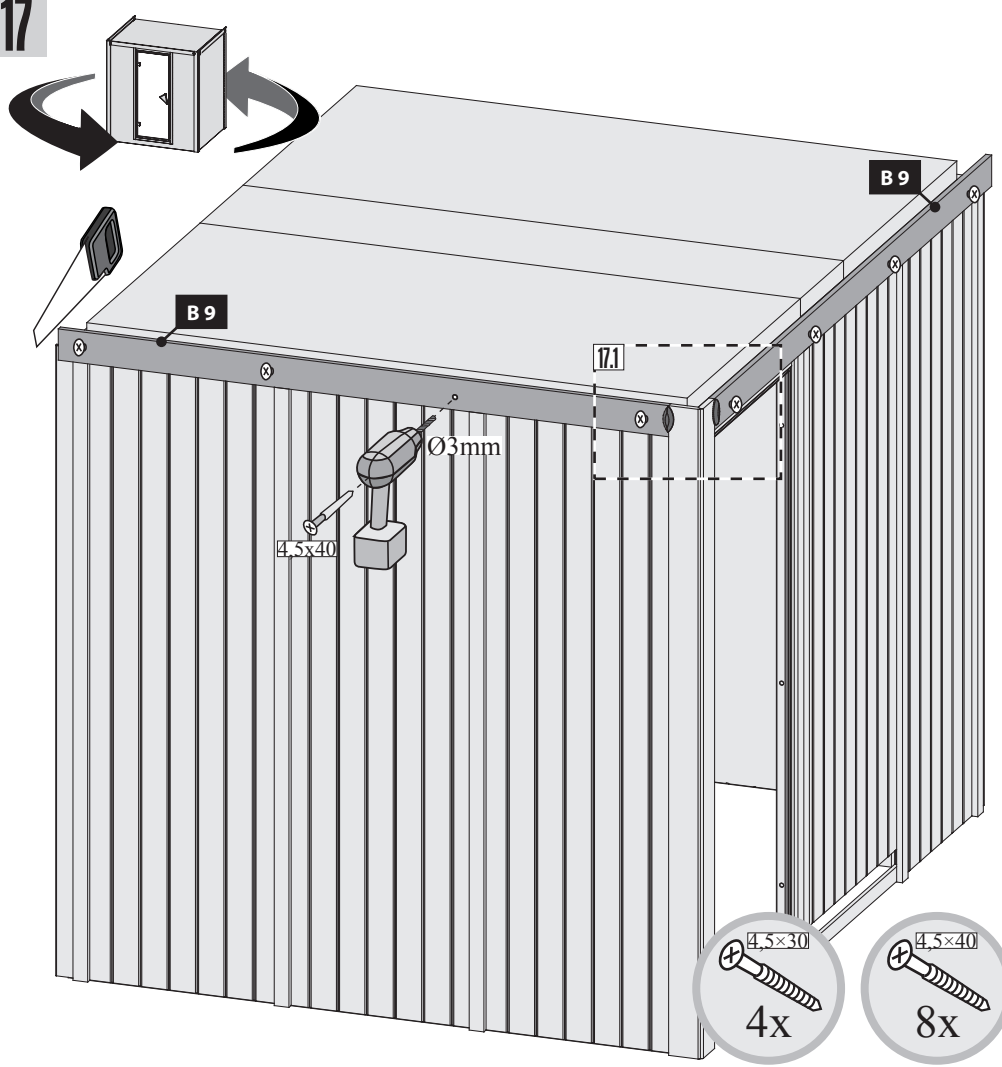

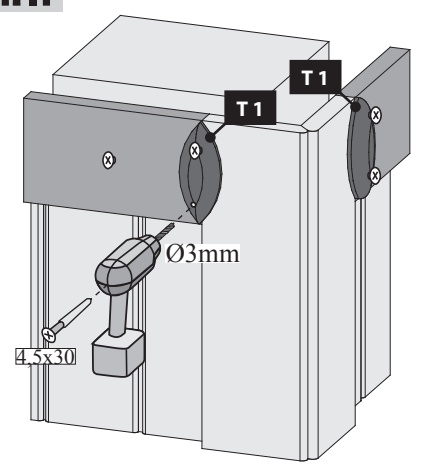

17.1



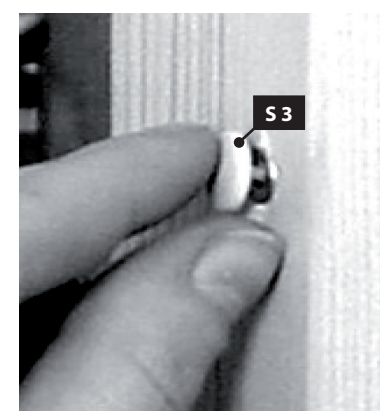

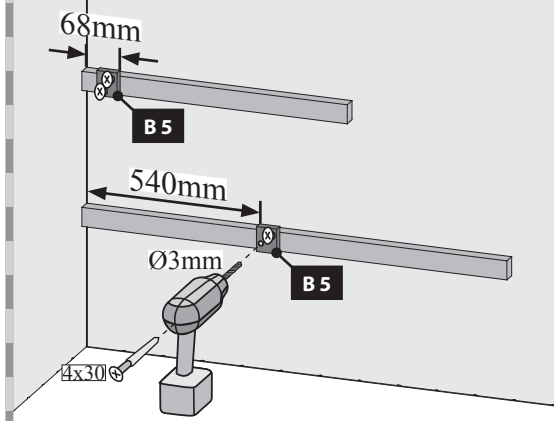
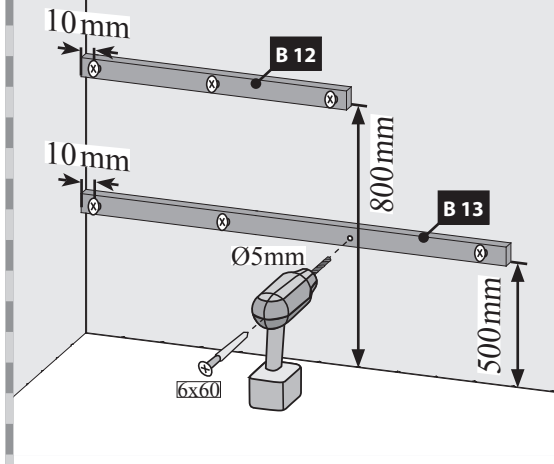
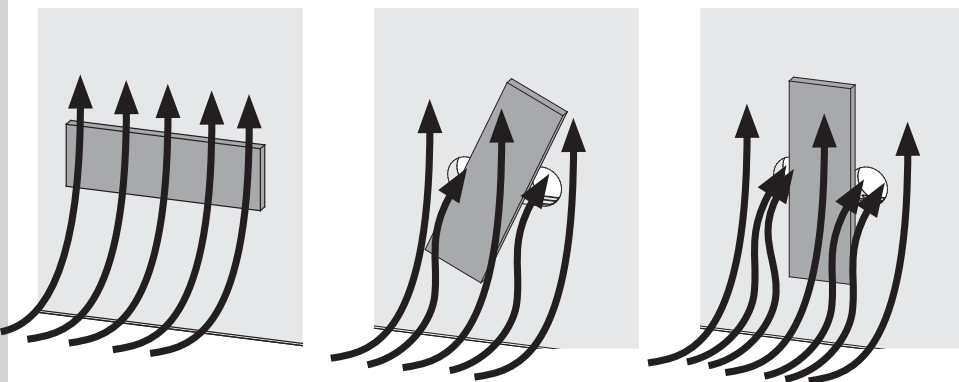
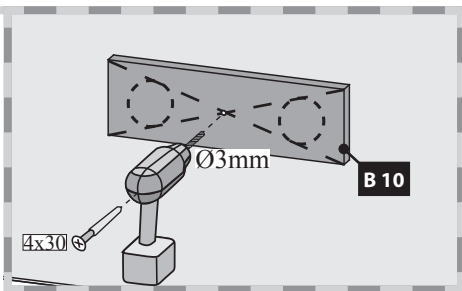
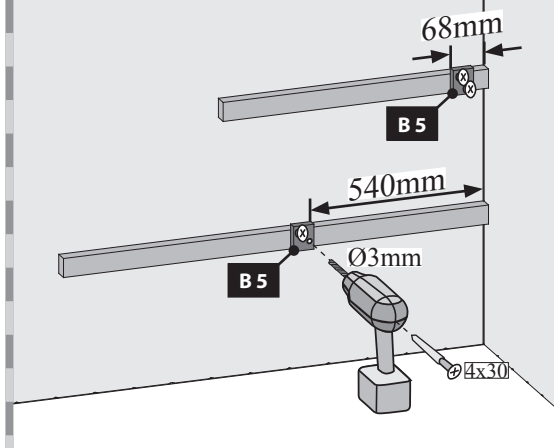
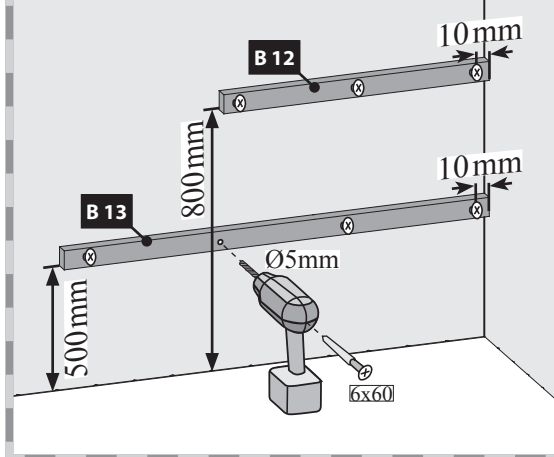
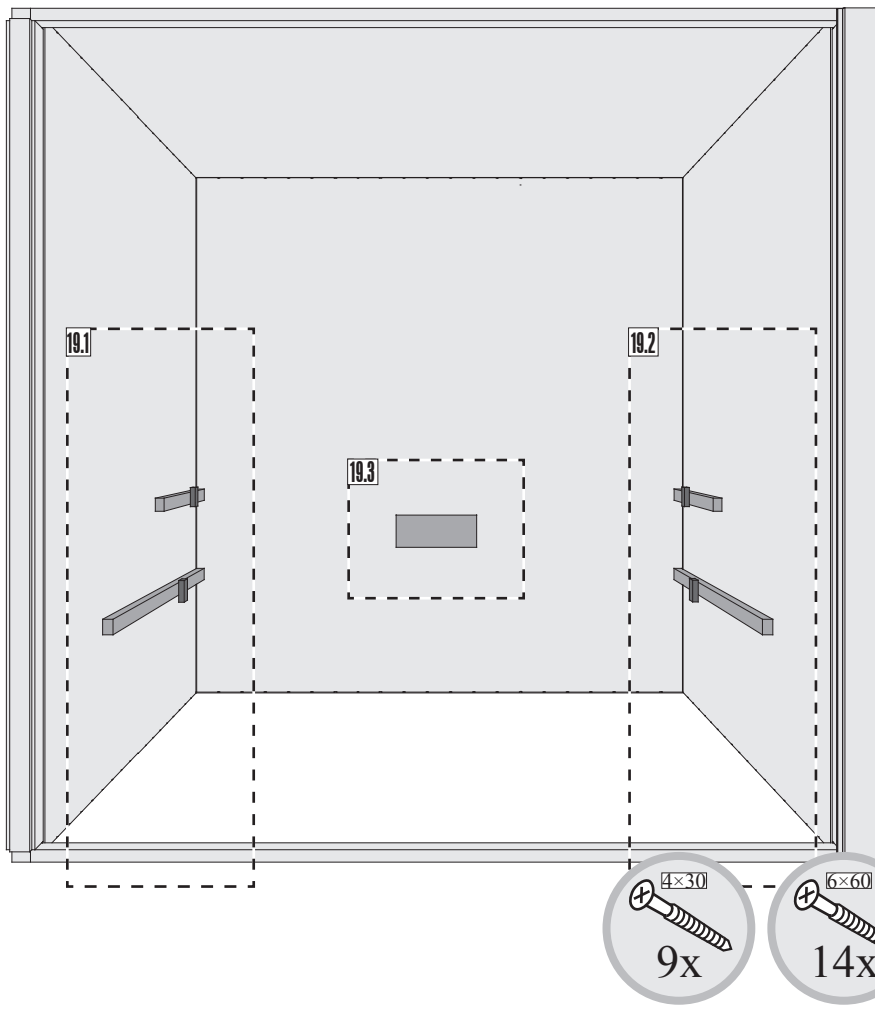
18







 Hier ist die Funktionsweise des Brettes abgebildet. Regeln Sie damit die Abluft nach Ihren eigenen Wünschen.

 Ceci représente le mode de fonctionnement de la planche. Avec elle, réglez l'écoulement de l'air selon vos désirs.

 This figure shows the functional principle of the board. Regulate the exhaust air according to your own wishes.

 Hier is de werking van het plankje afgebeeld. Regel daarmee de luchtafvoer naar eigen wens.

 Aquí está representada la forma de funcionamiento de la tabla. Regule con ello el aire de salida según sus propios deseos.

 Viene illustrato il principio di funzionamento della tavoletta di regolazione della ventilazione. Con essa si può regolare a piacere la ventilazione.

 Zde je zobrazená funkce desky. Regulujte s ní odsávací vzduch dle Vašeho přání.

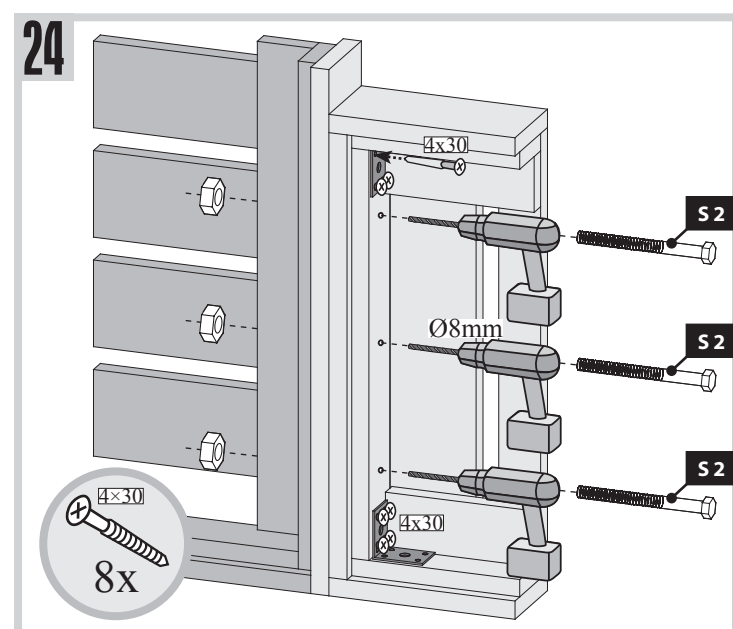
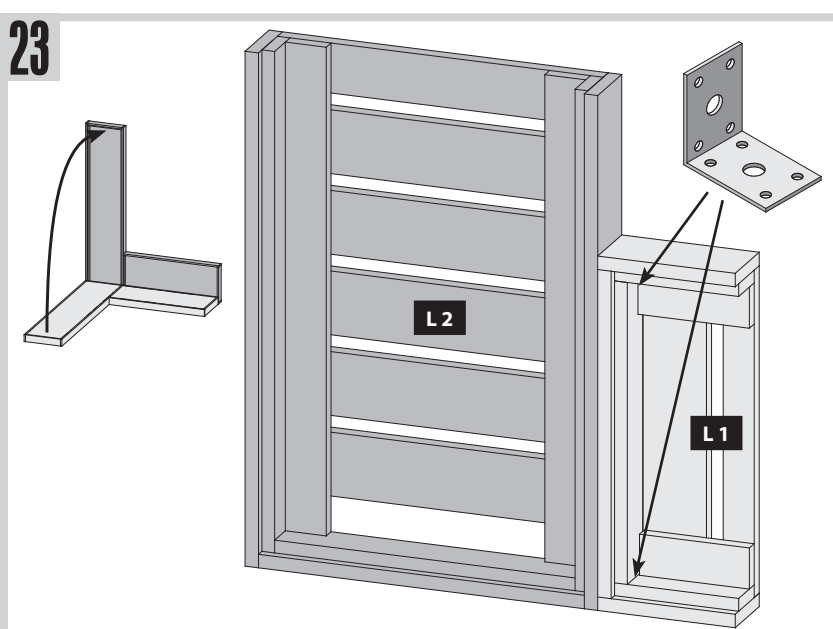
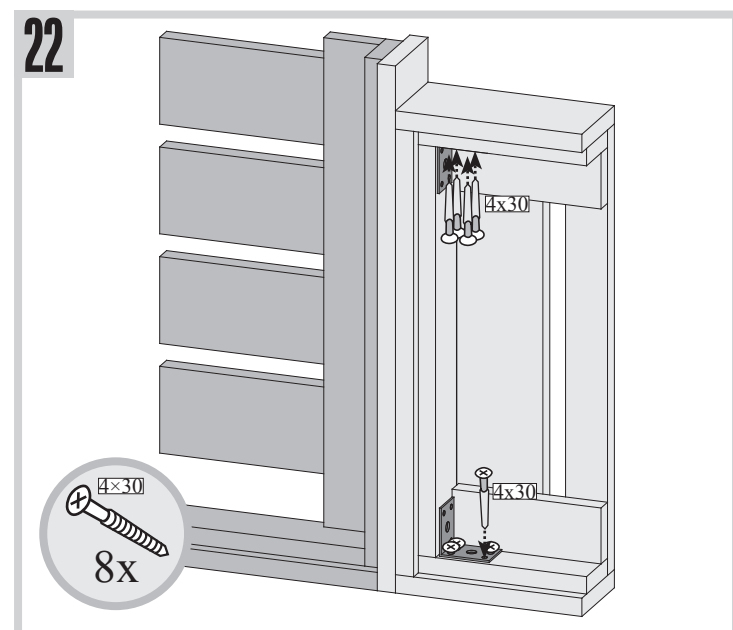
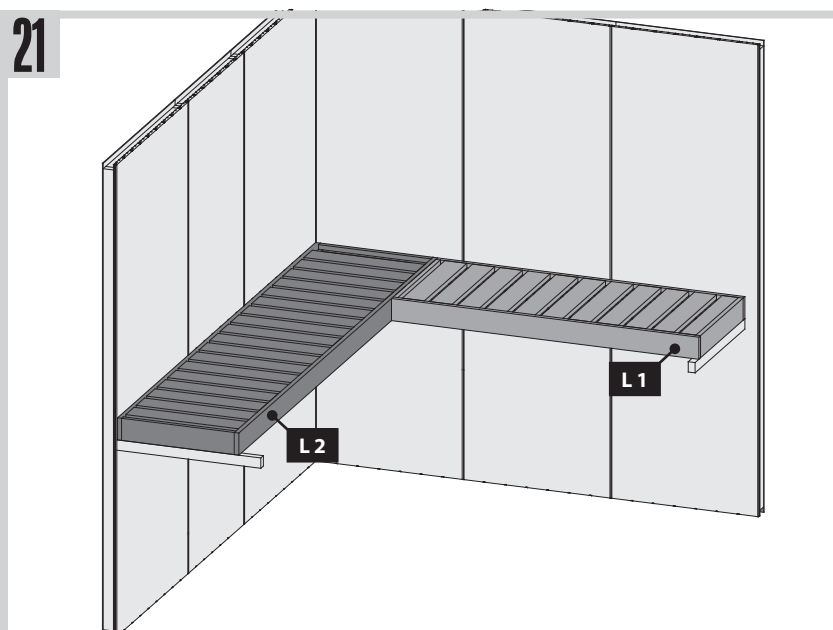
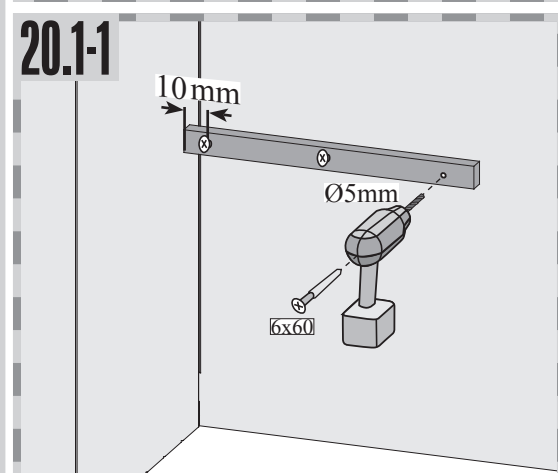
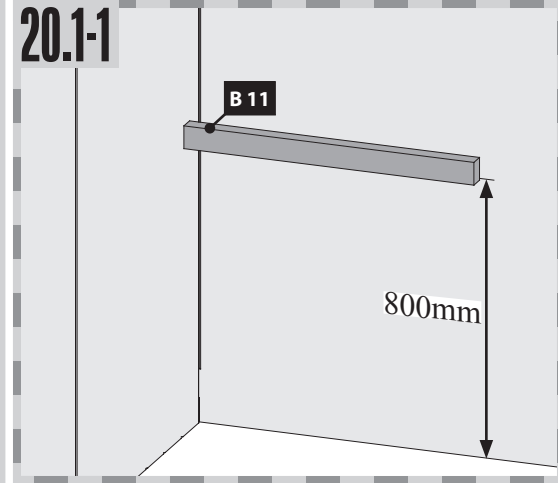
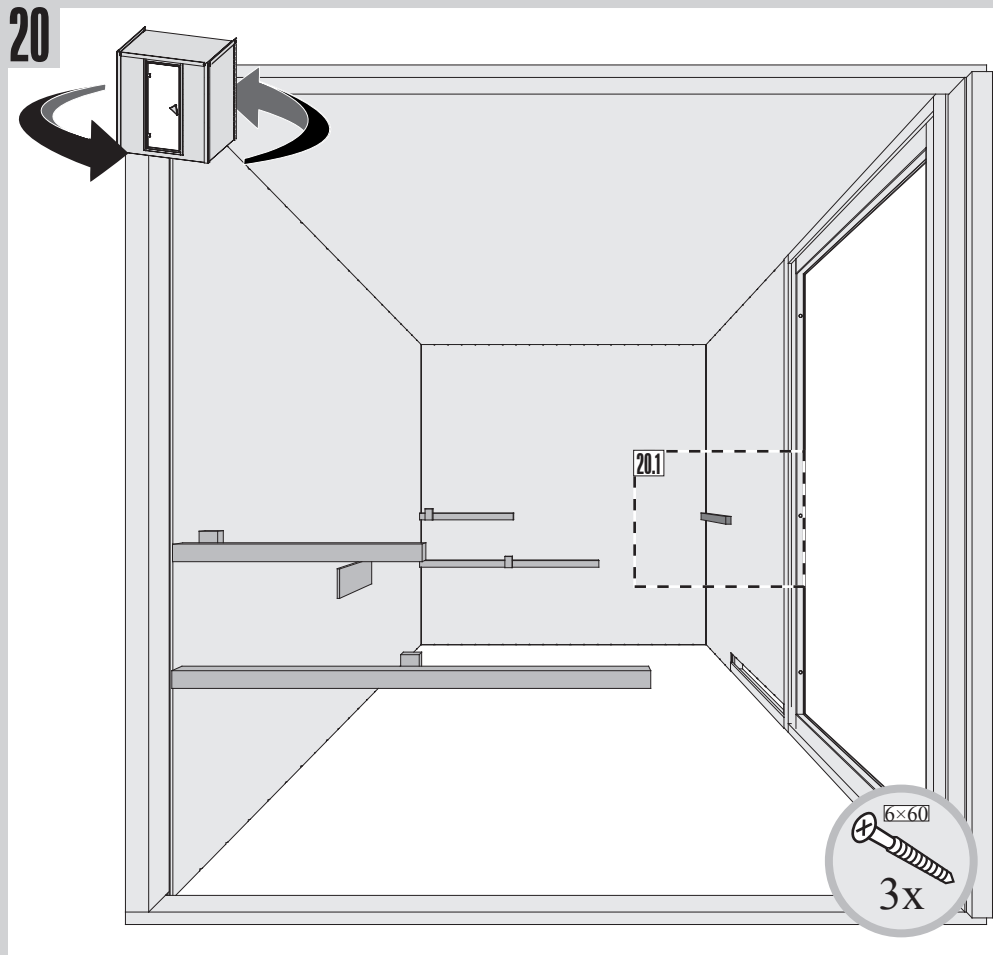

25

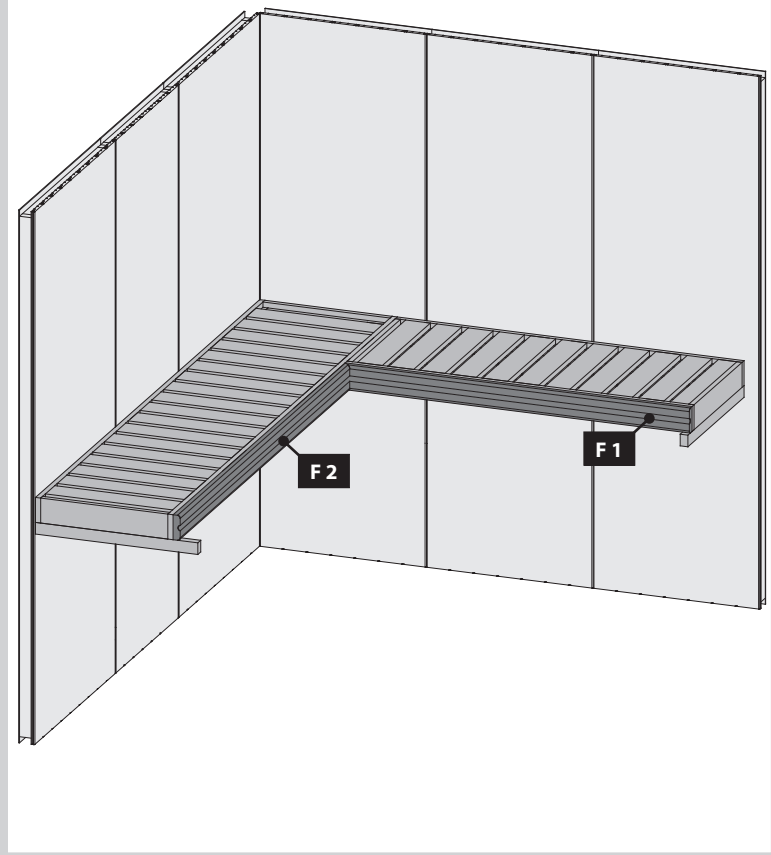

26

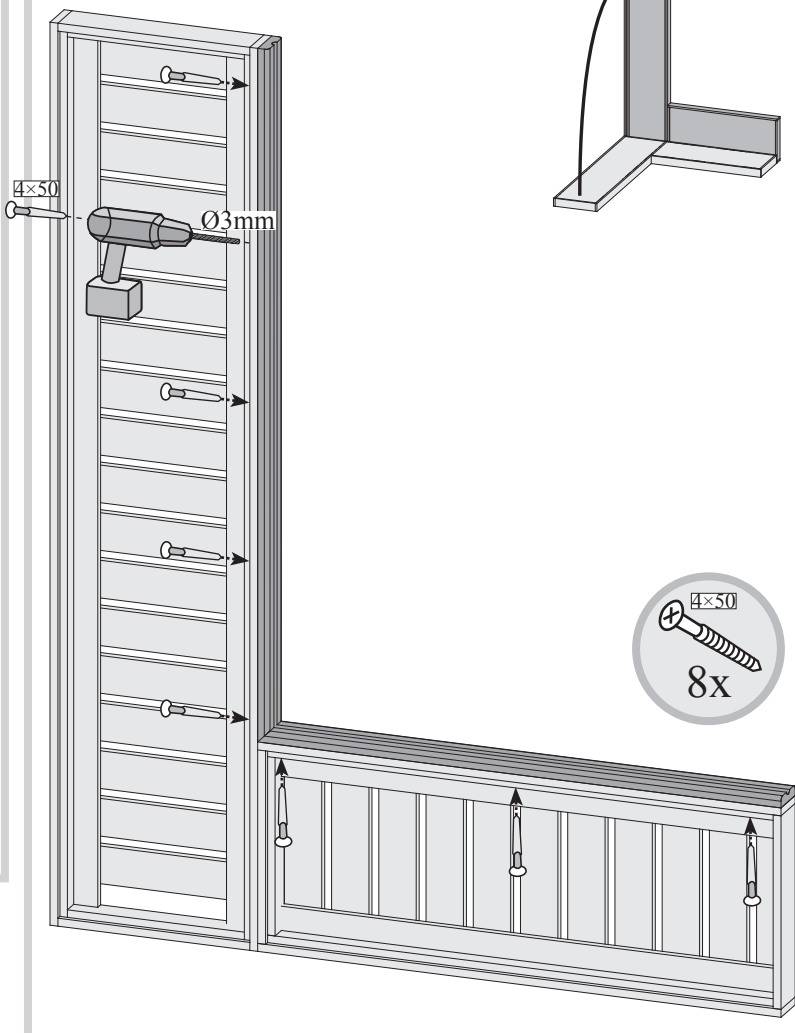

27

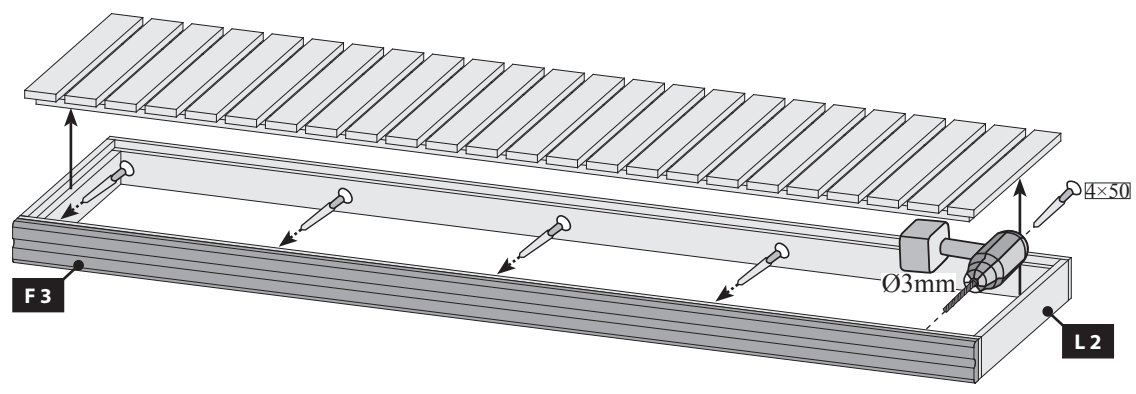

28 2x

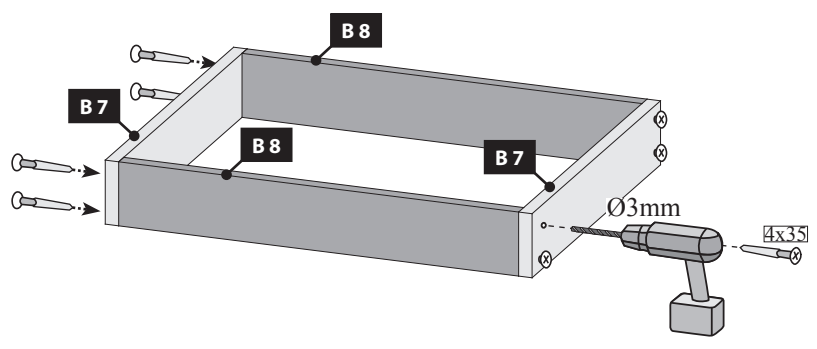

# 29 a

-  Nur bei 9 kW-Ofen
-  Seulement 9 kW chauffe
-  Only 9 kW heater
-  Slechts 9 kW heater
-  Sólo calentador de 9 kW
-  Solo riscaldamento 9 kW
-  Pouze topné těleso 9 kW

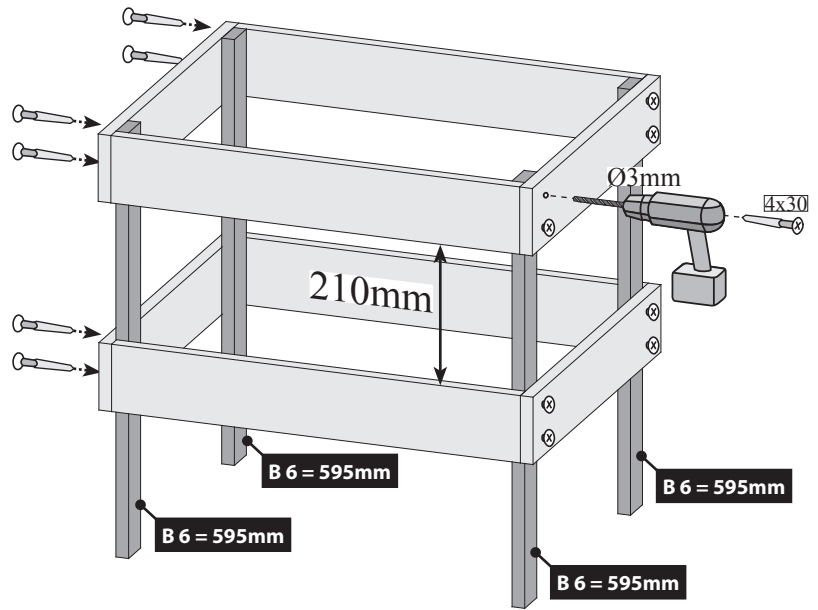
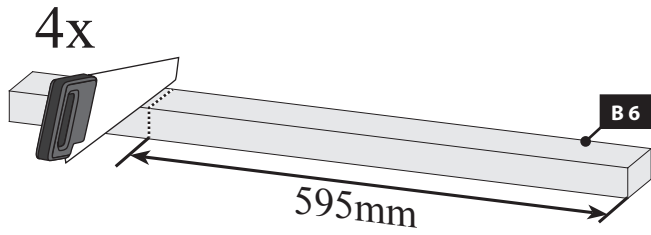

# 29 b

-  Bei allen anderen Öfen
-  Pour tous les autres fours
-  For all other furnaces
-  Voor alle andere ovens
-  Para todos los otros hornos
-  Per tutti gli altri tipi di forni
-  U všech ostatních pecích

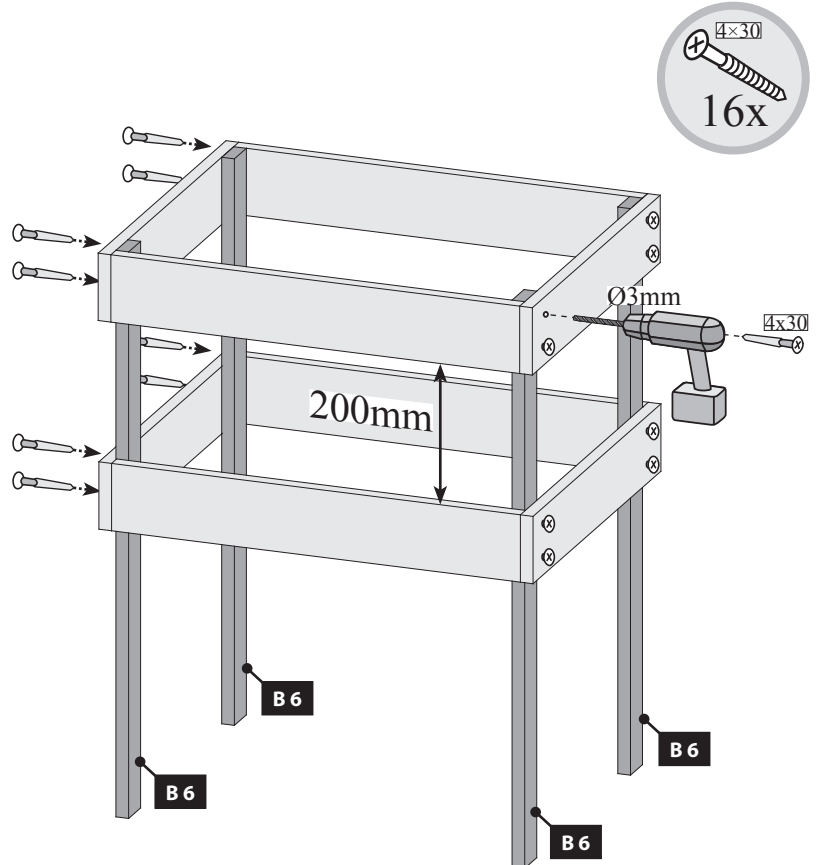

30

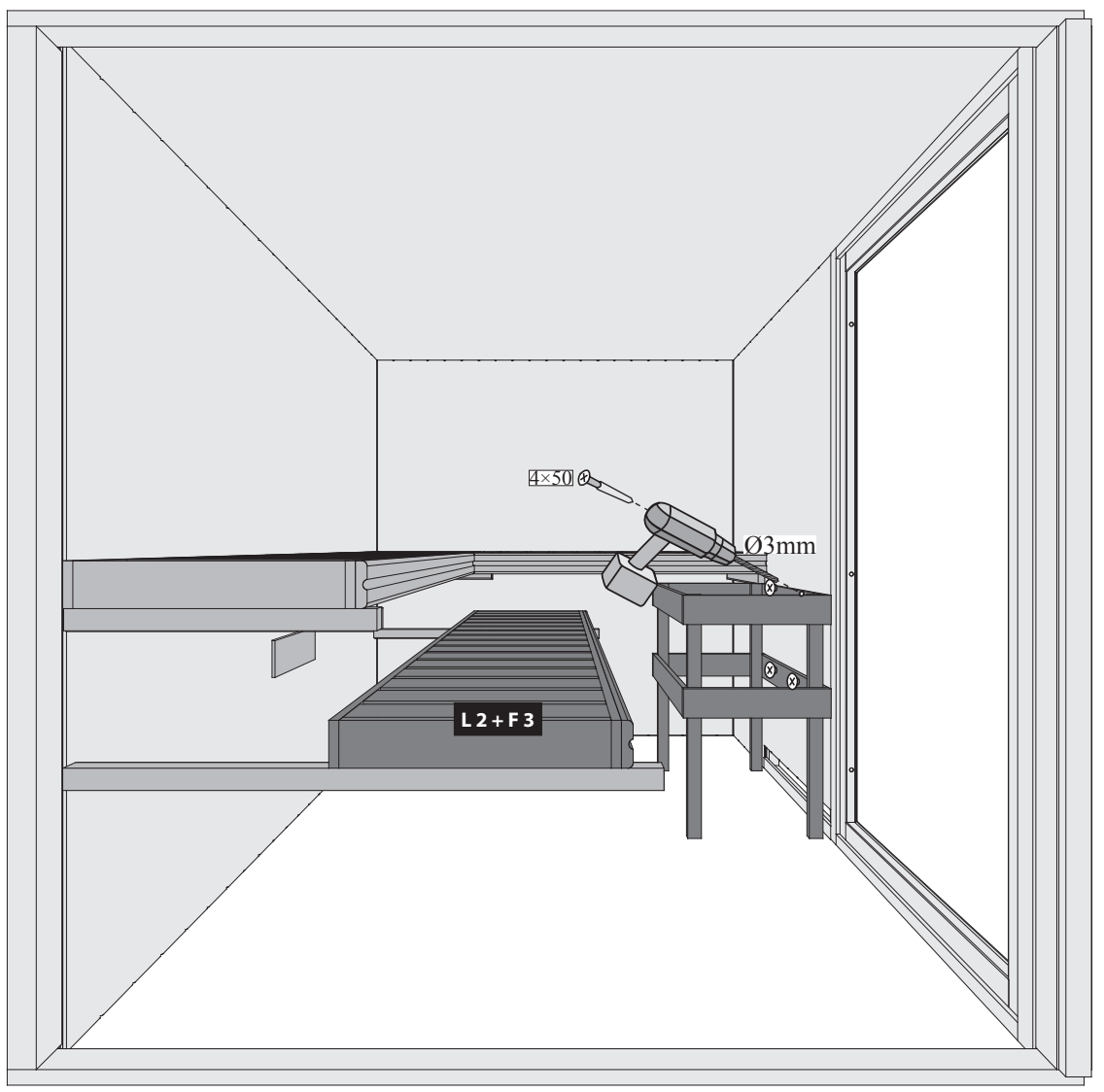
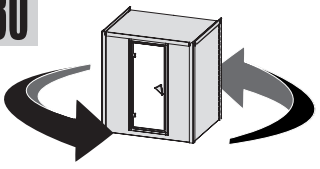

31

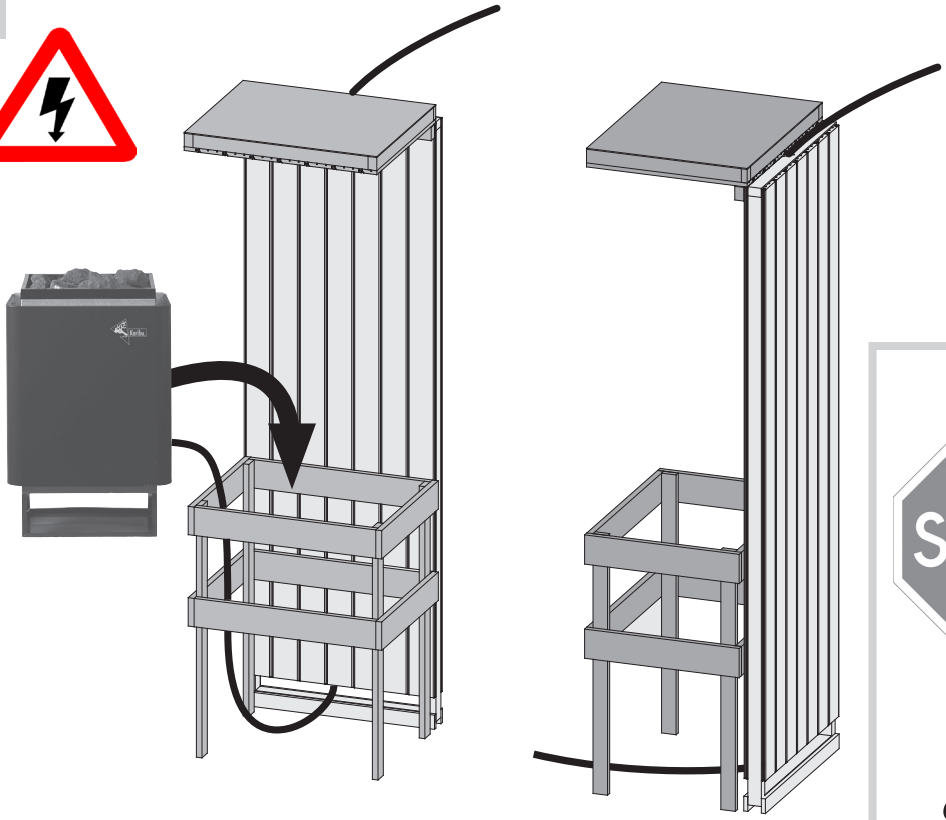

 Einbau Saunatur  
 Installation de porte Sauna  
 Sauna door installation  
 Sauna deur installatie  
 Instalación de la puerta Sauna  
 Installazione porta Sauna  
 Sauna Instalace dveře







 Installation TÜV-Schild

 Installatie TÜV Shield

 Instalace TÜV Shield

 Installation TÜV Shield

 Installazione TÜV Shield

 Namestitev TÜV tablice

 Installation TÜV Shield

 Instalación TÜV Escudo

01

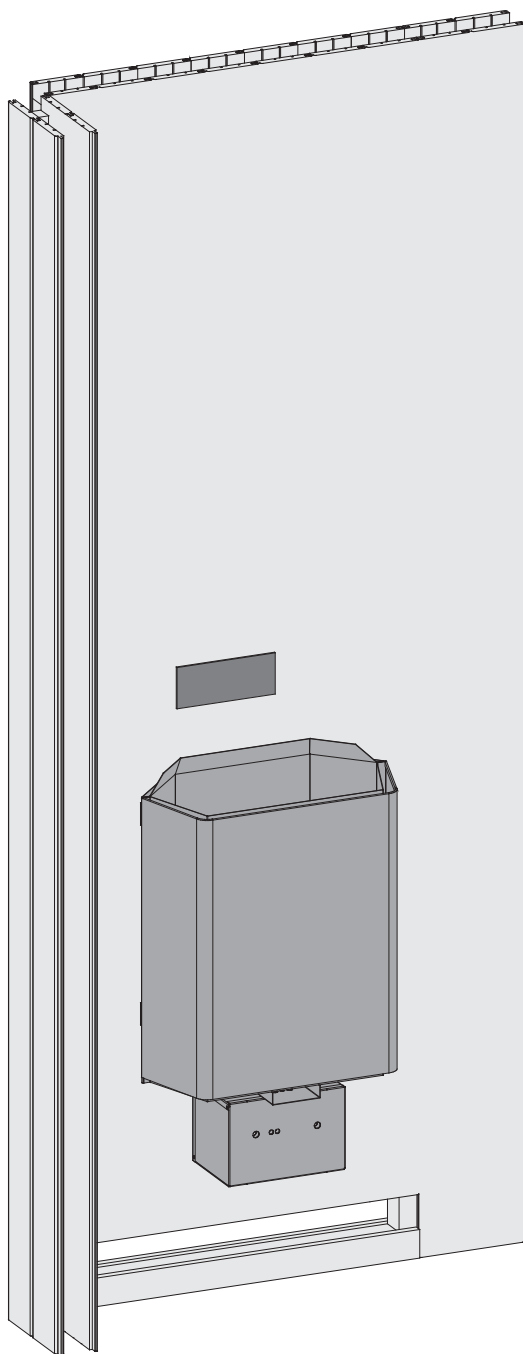



 Entfernen Sie die Schutzfolie vom beiliegenden TÜV-Schild. Lassen Sie den Saunaofen von einem zugelassenen Elektrofachmann anschließen. Dieser markiert den installierten Ofen auf dem TÜV-Schild. Bringen Sie das TÜV-Schild an einer gut sichtbaren Stelle über dem Ofen an.

 Remove the protective film from the accompanying Participate Schild. Lassen connecting the heater by a licensed electrician. This marks the installed furnace on the TÜV sign. Attach the TÜV sign at a conspicuous place on the stove.

 Retirez le film protecteur de l'accompagnant Participer Schild. Lassen raccorder l'appareil par un électricien agréé. Ceci marque le four installé sur le signe TÜV. Fixer le signe de TÜV à un endroit bien en vue sur le poêle.

 Verwijder de beschermfolie van de begeleidende Deelnemen Schild. Lassen het aansluiten van de kachel, door een erkende elektricien. Dit markeert de geïnstalleerde oven op het TÜV teken. Bevestig de TÜV teken op een opvallende plaats op het fornuis.

 Rimuovere la pellicola protettiva dal accompagna Partecipa Schild. Lassen collegando il riscaldatore da un elettricista qualificato. Questo segna il forno installato sul segno TÜV. Fissare il segno TÜV in un luogo ben visibile sulla stufa.

 Retire la película protectora de la Schild. Lassen acompaña Participar conectar el calentador por un electricista autorizado. Esto marca el horno instalado en el signo TÜV. Coloque el cartel de TÜV en un lugar visible en la estufa.

02

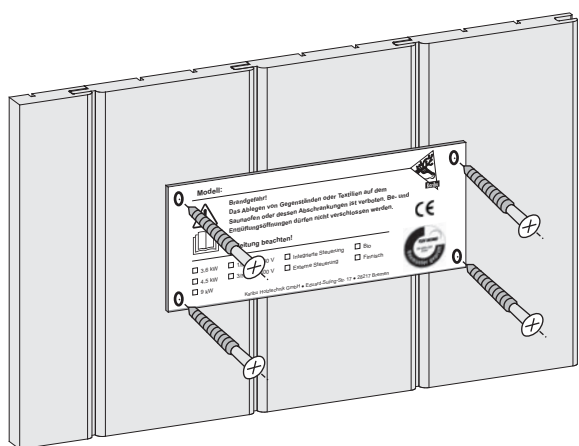

 Odstraňte ochrannou fólii z doprovodného Hlavní Schild. Lassen připojení ohříváče licencovaným elektrikář. Toto označí Instalovaný pec na znamení TÜV. Připevněte znamení TÜV na dobře viditelném místě na sporáku.

 S priložene tablice odstranite zaščitno folijo. Peč savne naj priključi usposobljeno osebnje, ki inštalirano peč označi na TÜV tablici. Tablico namestite na vidno mesto peči.





80887

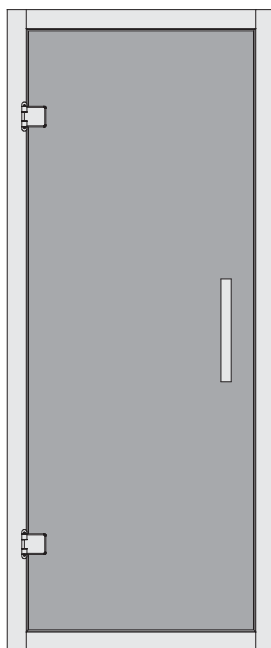

-  **Aufbauanleitung**
-  **Building Instructions**
-  **notice de montage**
-  **montagehandleiding**
-  **Montagevejledning**
-  **Instrucciones de construcción**
-  **Istruzioni per il montaggio**
-  **Montážní návod**

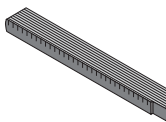
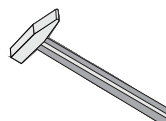
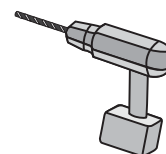
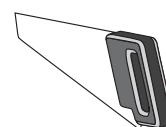



Vergleichen Sie zuerst die Material-liste mit Ihrem Paketinhalt! Bitte haben Sie Verständnis, dass Beanstandungen nur im nicht aufgebauten Zustand bearbeitet werden können!



Vergelijk eerst de lijst van materialen met de inhoud van uw pakket! Reclamaties kunnen alleen in behandeling worden genomen zolang de onderdelen nog niet zijn gemonteerd!



Confrontate questa distinta materiali prima con il contenuto del pacchetto! Vi preghiamo di comprendere che eventuali reclami possono essere accolti solo prima del montaggio!



First compare the list of materials with your package contents! Please understand that complaints can be processed in the non-built status only!



Start med at kontrollere materialelisten med indholdet af den leverede pakke! Vi gør venligst opmærksom på at reklamationer kun kan behandles for materialer som ikke er blevet bearbejdet!



Nejprve přezkontrolujte obsah balení podle materiálového listu! Mějte pochopení pro to, že případnou reklamaci se můžeme zabývat pouze tehdy, když díly nebudou smontované! Za pomoci tohoto seznamu můžete jednotlivé díly přiřadit k montážnímu návodu.



Commencez par comparer la liste du matériel avec le contenu de votre paquet! Sachez que nous traitons uniquement les réclamations concernant le matériel à l'état non monté!



En primer lugar, compare la lista de material con el contenido del paquete. Rogamos entienda que las reclamaciones sólo pueden ser tramitadas antes de montar el objeto!

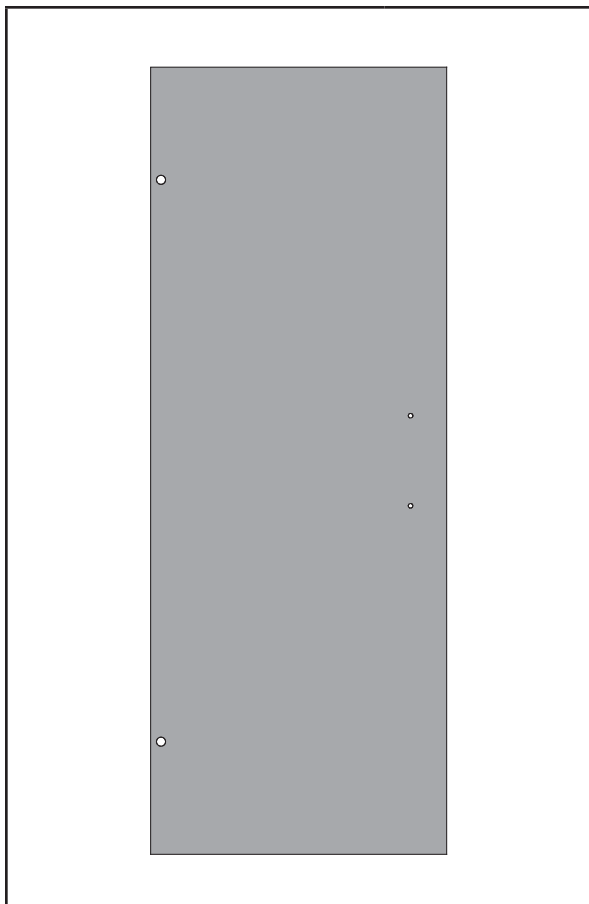
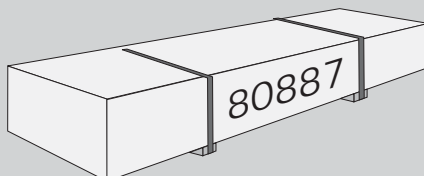

1 x

ID 74001

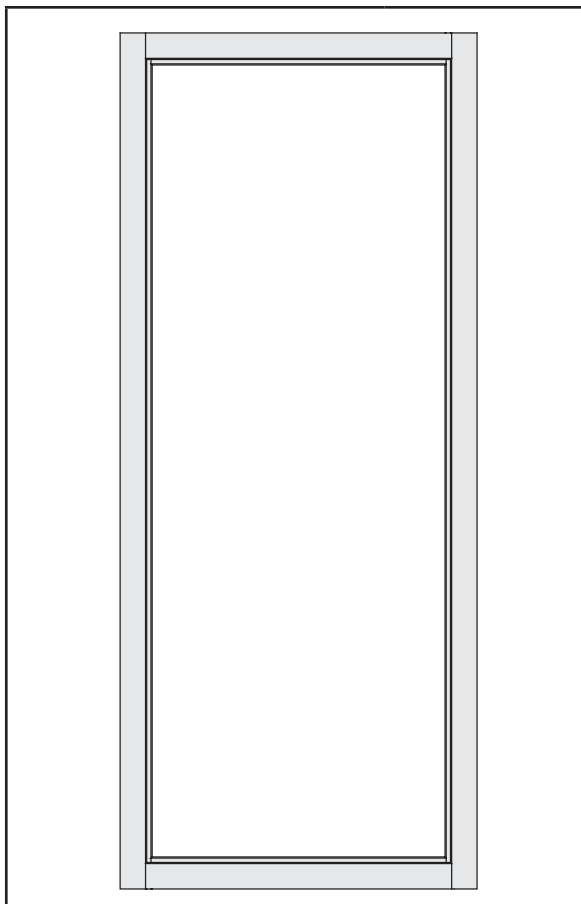

1 x

ID 26499



Bitte beachten Sie, dass es sich bei einem Spontanbruch infolge von Nickelsulfideinschlüssen um Glasbrüche handelt, die nicht auf Verarbeitungsfehler basieren und somit nicht durch den Hersteller und dem Verarbeiter zu vertreten sind. Der Spontanbruch ist als hinzunehmendes Allgemeinrisiko anzusehen.

Bitte haben Sie Verständnis, dass wir eine Nachlieferung nur gegen Berechnung ausführen können.

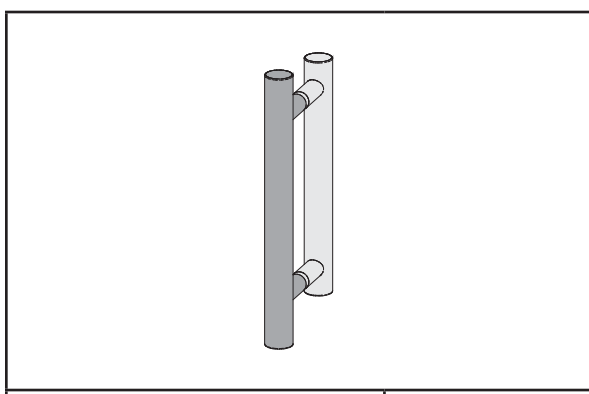



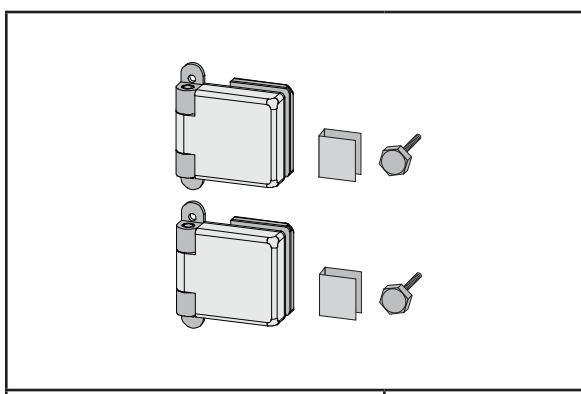

1 x





ID 70349



1 x

ID 70348

-  Einbau Glastür
-  Installation of glass door
-  Montage porte en verre
-  Montage van de glazen deur

-  Installationsglasdør
-  Montaje de la puerta de cristal
-  Installazione portello di vetro
-  Sauna Instalace dveře

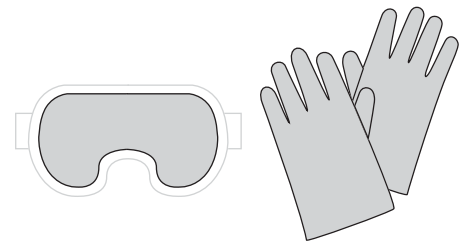

# 01



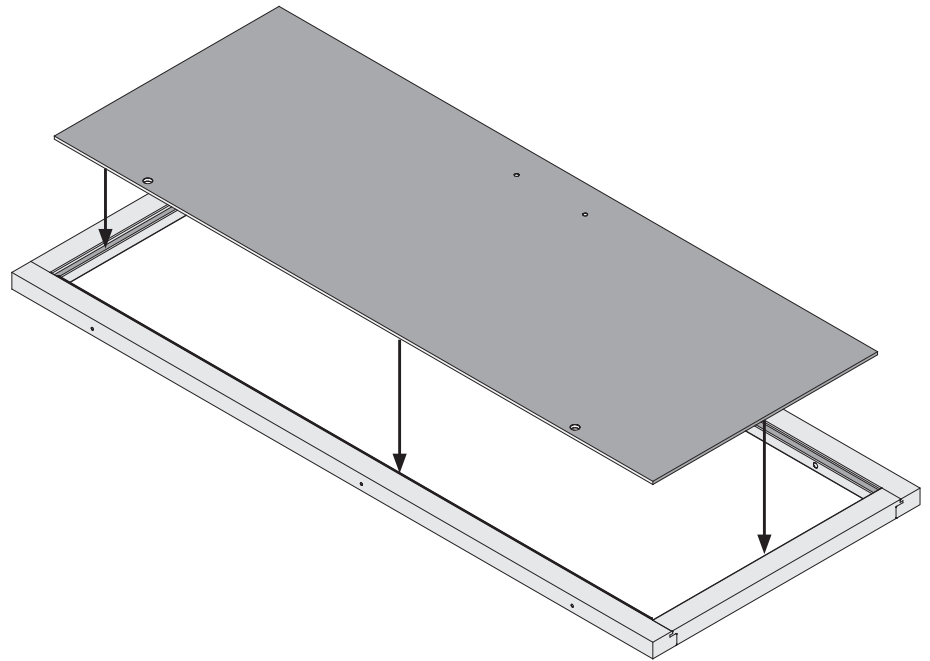

-  Saunätürglas in den Türrahmen legen
-  Put the door glass in the frame
-  Mettez le verre de la porte dans le cadre
-  Plaats het deurglas in het frame
-  Sæt dørglasset i rammen
-  Pon el vidrio de la puerta en el marco
-  Metti il vetro della porta nel telaio
-  Vložte sklo dveří do rámu



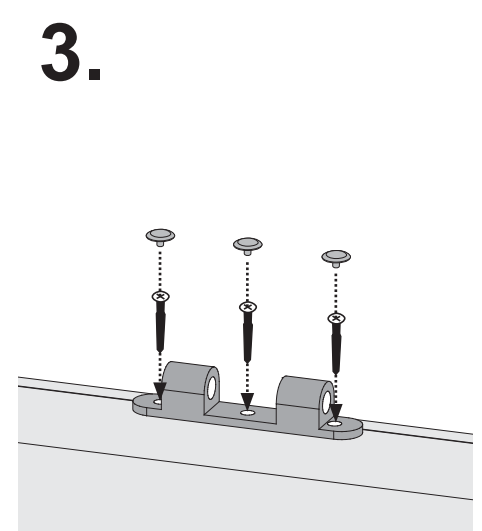
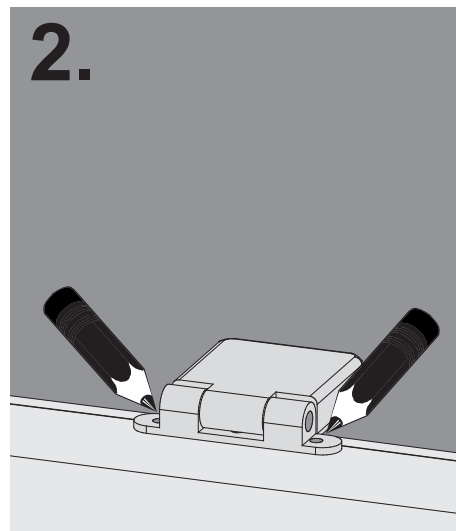
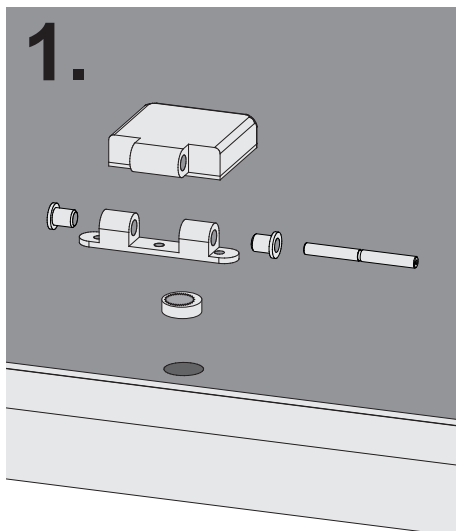
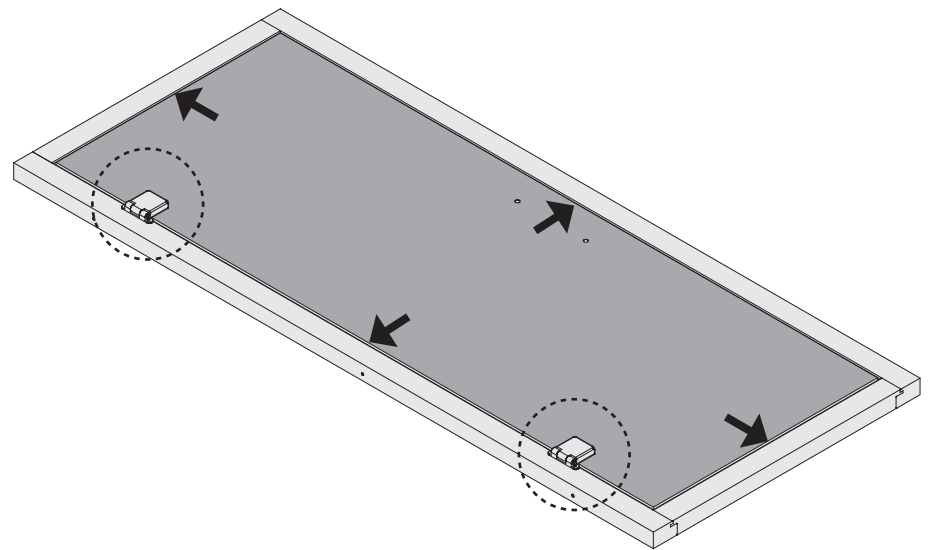



# 02

-  Saunätürglas in den Türrahmen ausrichten
-  Center the glass in the wooden frame
-  Bien aligner le verre à vitre
-  Lijn het glas uit in het deurframe
-  Juster saunaens dørglas i dørkarmen
-  Alinee el vidrio en el marco de la puerta
-  Allineare il vetro nel telaio della porta
-  Skleněná dvířka sauna v zárubně zarovnat



 Einbau Glastür  
 Installation of glass door  
 Montage porte en verre  
 Montage van de glazen deur

 Installationsglasdør  
 Montaje de la puerta de cristal  
 Installazione portello di vetro  
 Sauna Instalace dveře

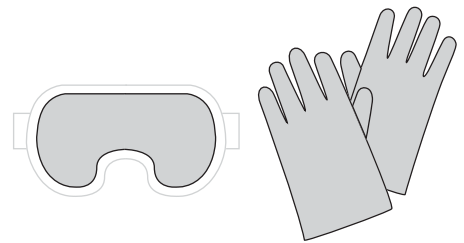

03

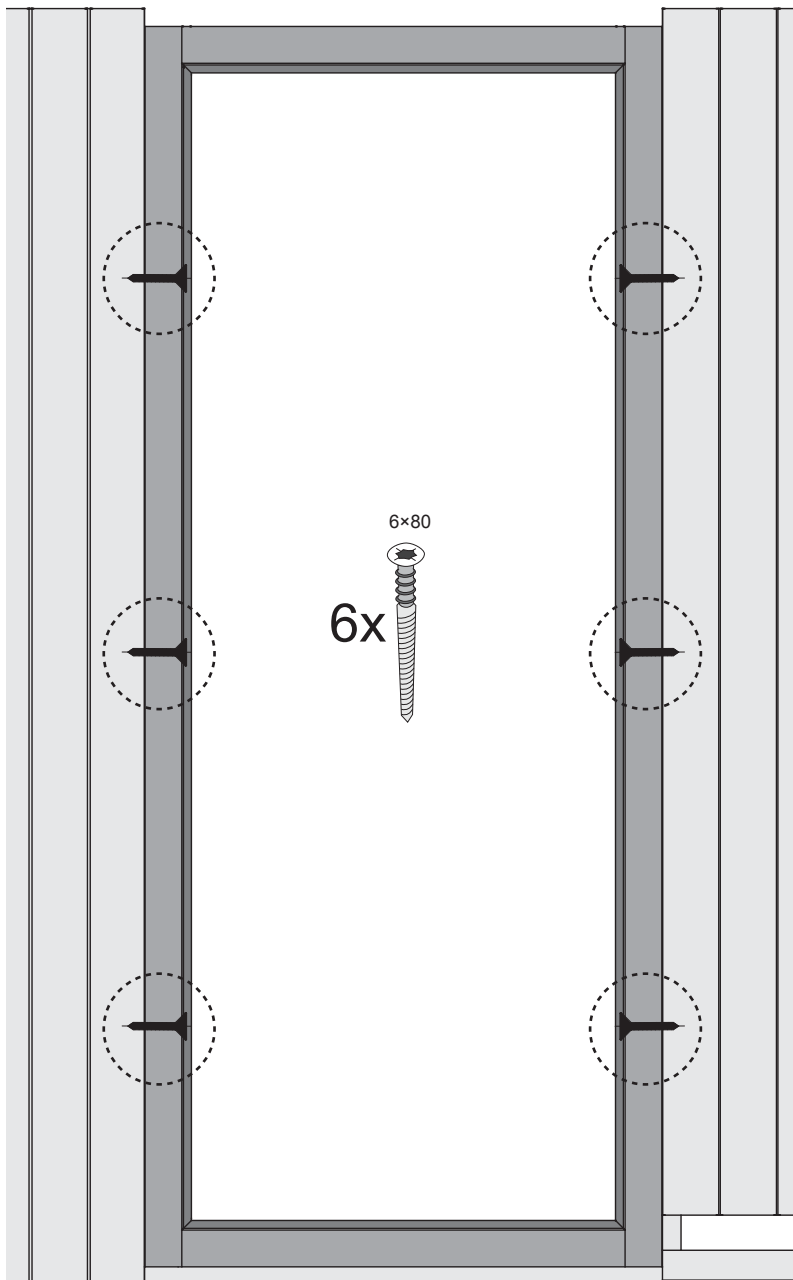
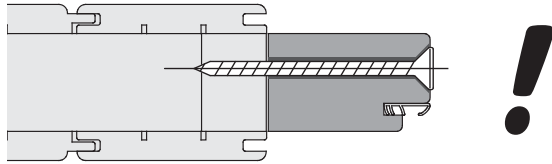



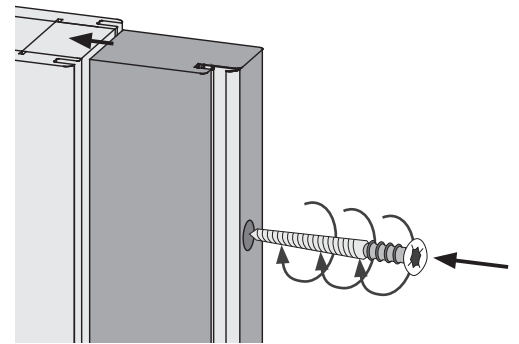



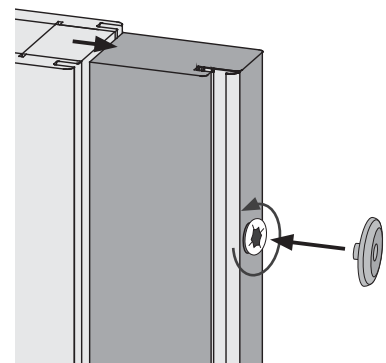

1.



2.



-  Einbau Glastür
-  Installation of glass door
-  Montage porte en verre
-  Montage van de glazen deur

-  Installationsglasdør
-  Montaje de la puerta de cristal
-  Installazione portello di vetro
-  Sauna Instalace dveře

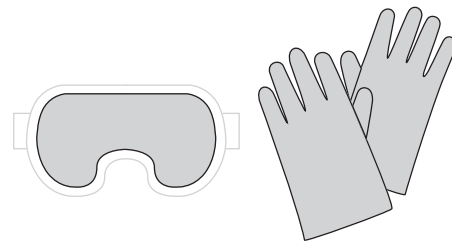

04

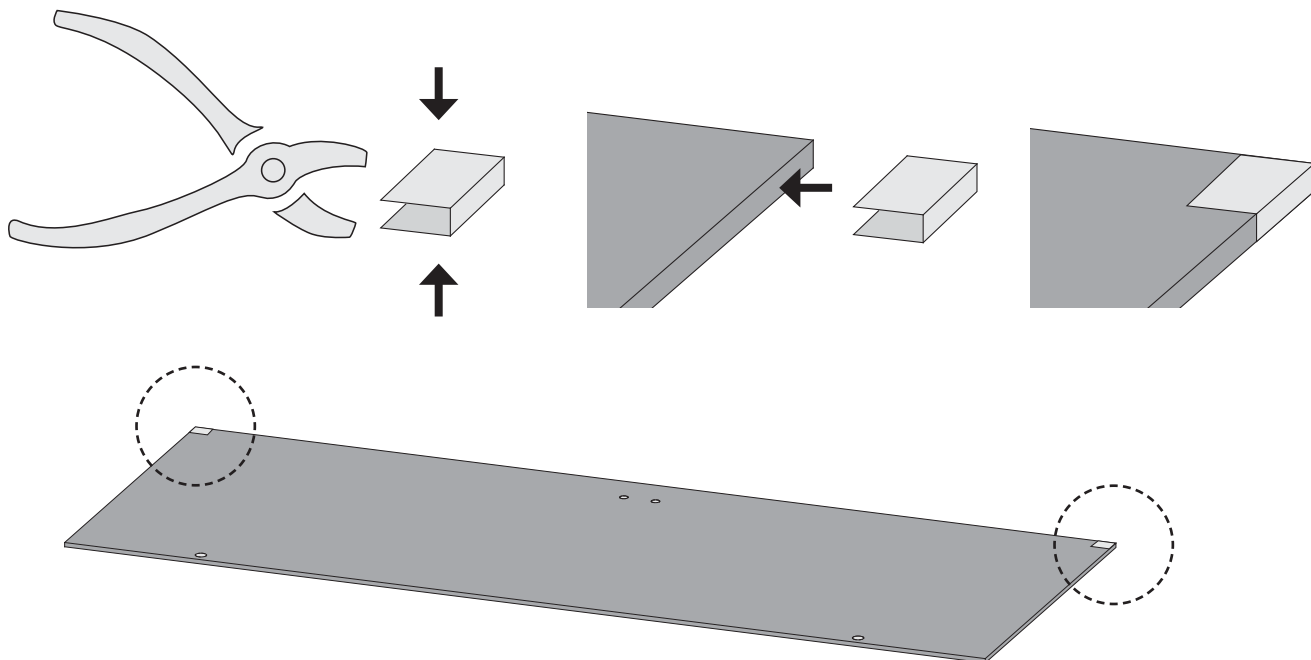



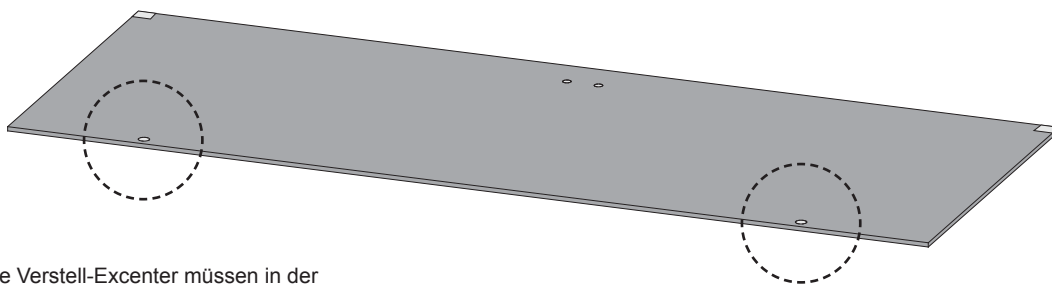



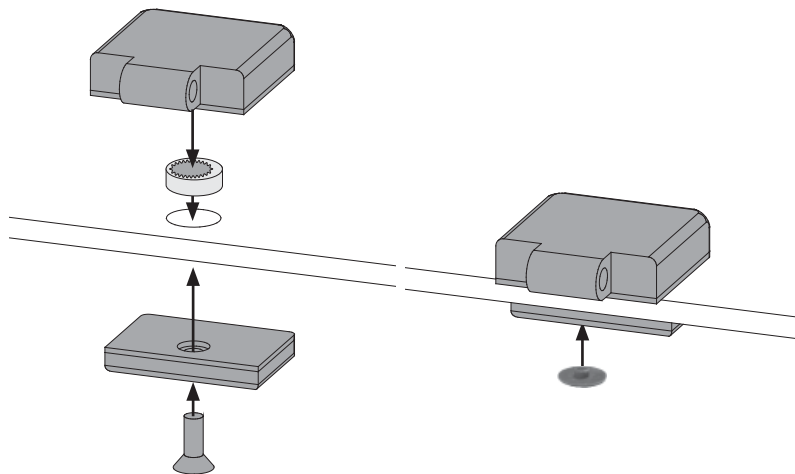

05



-  Alle Verstell-Excenter müssen in der Glasscheibe die gleiche Grundstellung haben
-  All adjustable eccentrics must have the same basic adjustment in the glass panel
-  Tous les excentreurs de positionnement doivent avoir la même position de base dans la vitre
-  Alle excentrische verstelelementen moeten in dezelfde stand in de glasplaat worden geplaatst
-  Alle justeringsexcenterer skal have samme grundlæggende position i glasruden
-  Todos los excéntricos regulables tienen que tener la misma posición base en la hoja de cristal
-  Tutti gli eccentrici di regolazione devono avere la stessa posizione base nella lastra di vetro
-  šechny nastavovací podivínů musí mít stejný základní polohy ve skle





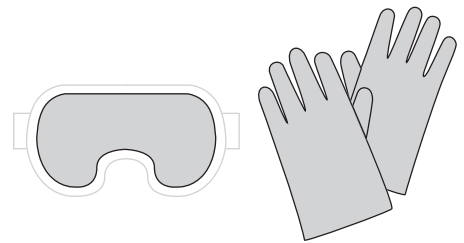

-  Einbau Glastür
-  Installation of glass door
-  Montage porte en verre
-  Montage van de glazen deur



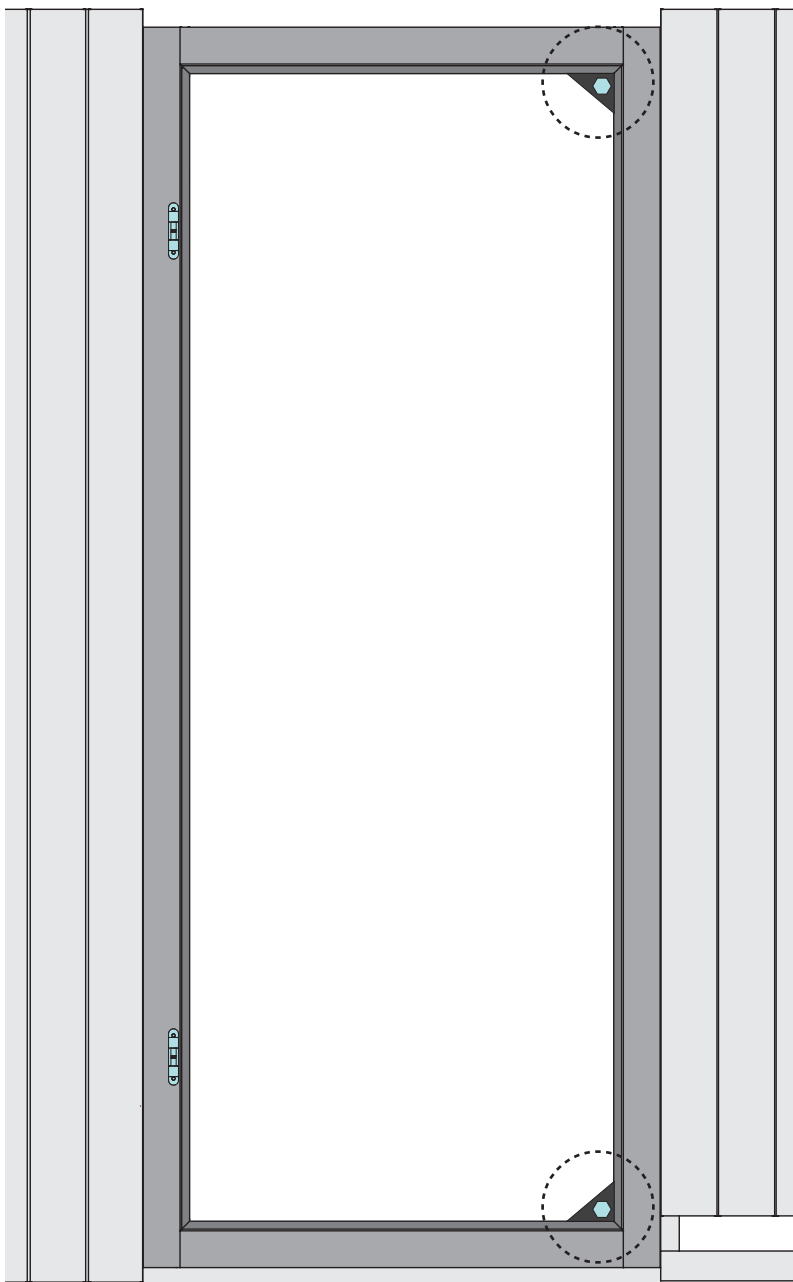

-  Installationsglasdør
-  Montaje de la puerta de cristal
-  Installazione portello di vetro
-  Sauna Instalace dveře



06







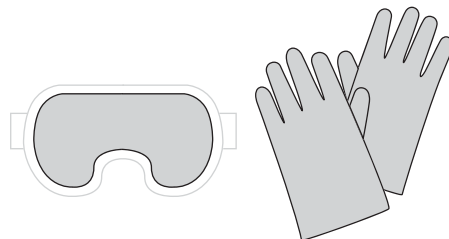



-  Einbau Glastür
-  Installation of glass door
-  Montage porte en verre
-  Montage van de glazen deur

-  Installationsglasdør
-  Montaje de la puerta de cristal
-  Installazione portello di vetro
-  Sauna Instalace dveře



# 07

-  Alle Verstell-Excenter müssen in der Glasscheibe die gleiche Grundstellung haben
-  All adjustable eccentrics must have the same basic adjustment in the glass panel
-  Tous les excentreurs de positionnement doivent avoir la même position de base dans la vitre
-  Alle excentrische verstelelementen moeten in dezelfde stand in de glasplaat worden geplaatst

-  Alle justeringsexcenter skal have samme grundlæggende position i glasruden
-  Todos los excéntricos regulables tienen que tener la misma posición base en la hoja de cristal
-  Tutti gli eccentrici di regolazione devono avere la stessa posizione base nella lastra di vetro
-  Šechny nastavovací podivínů musí mít stejný základní polohy ve skle

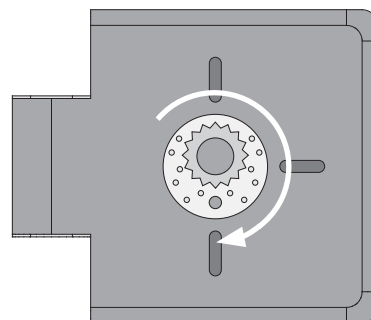
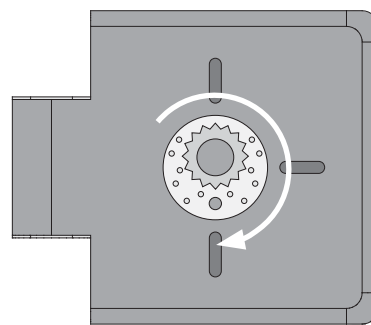
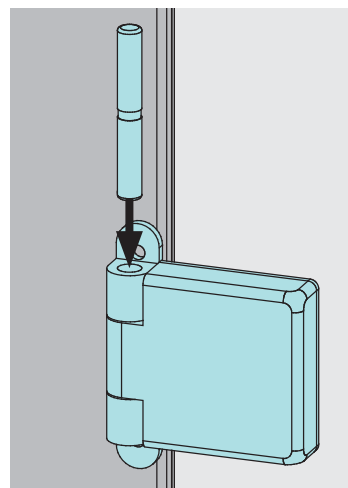
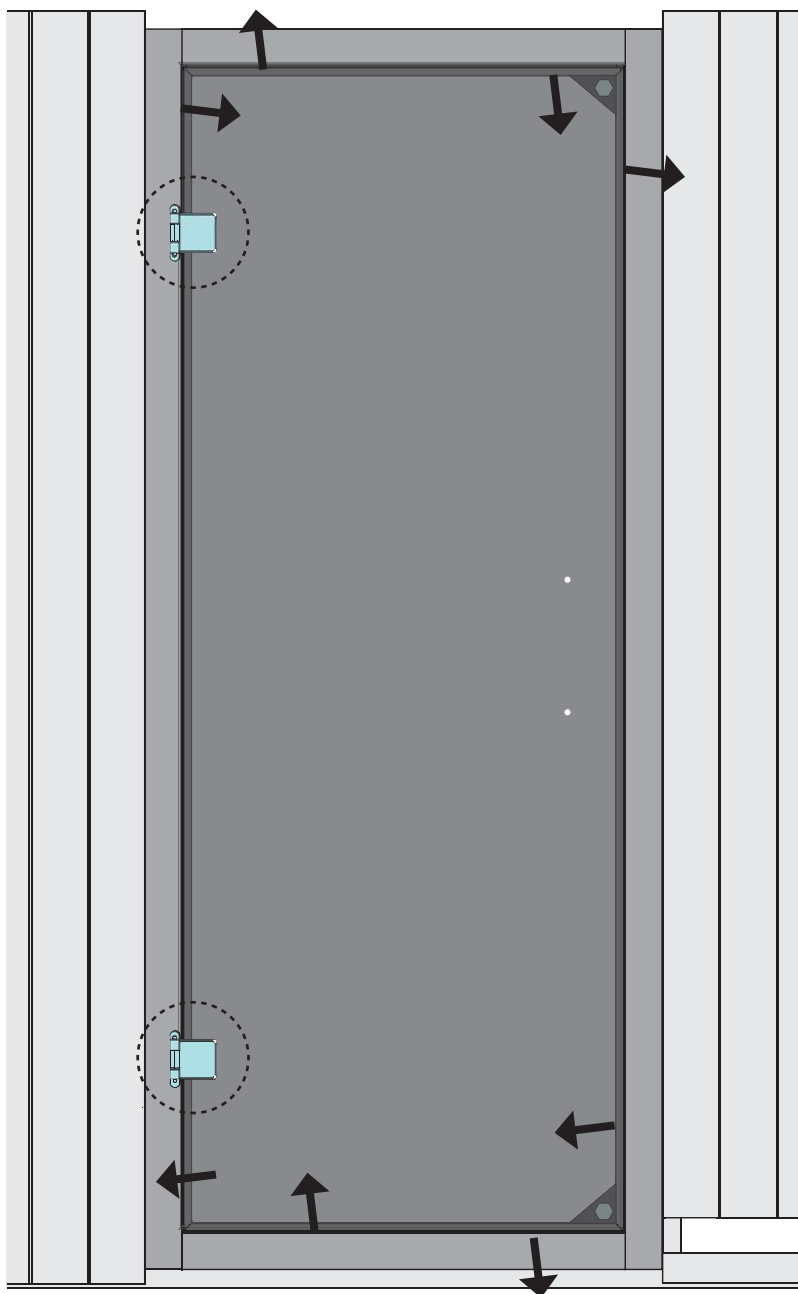

-  Außen: Metall  
Innen: Holz
-  Outside: metal  
Inside: wood
-  Extérieur: métal  
Intérieur: bois
-  Buiten: metaal  
Binnen: wood
-  Udenfor: metal  
Inde: træ
-  Exterior: metal  
Interior: madera
-  Esterno: metallo  
Interno: legno
-  Venku: kov  
Uvnitř: dřevo

