

Futonbett

# NOAH 140

DEUTSCH  
ENGLISH  
NEDERLANDSE  
FRANÇAIS  
SLOVENSKÝ  
ČESKÝ  
MAGYAR  
HRVATSKI

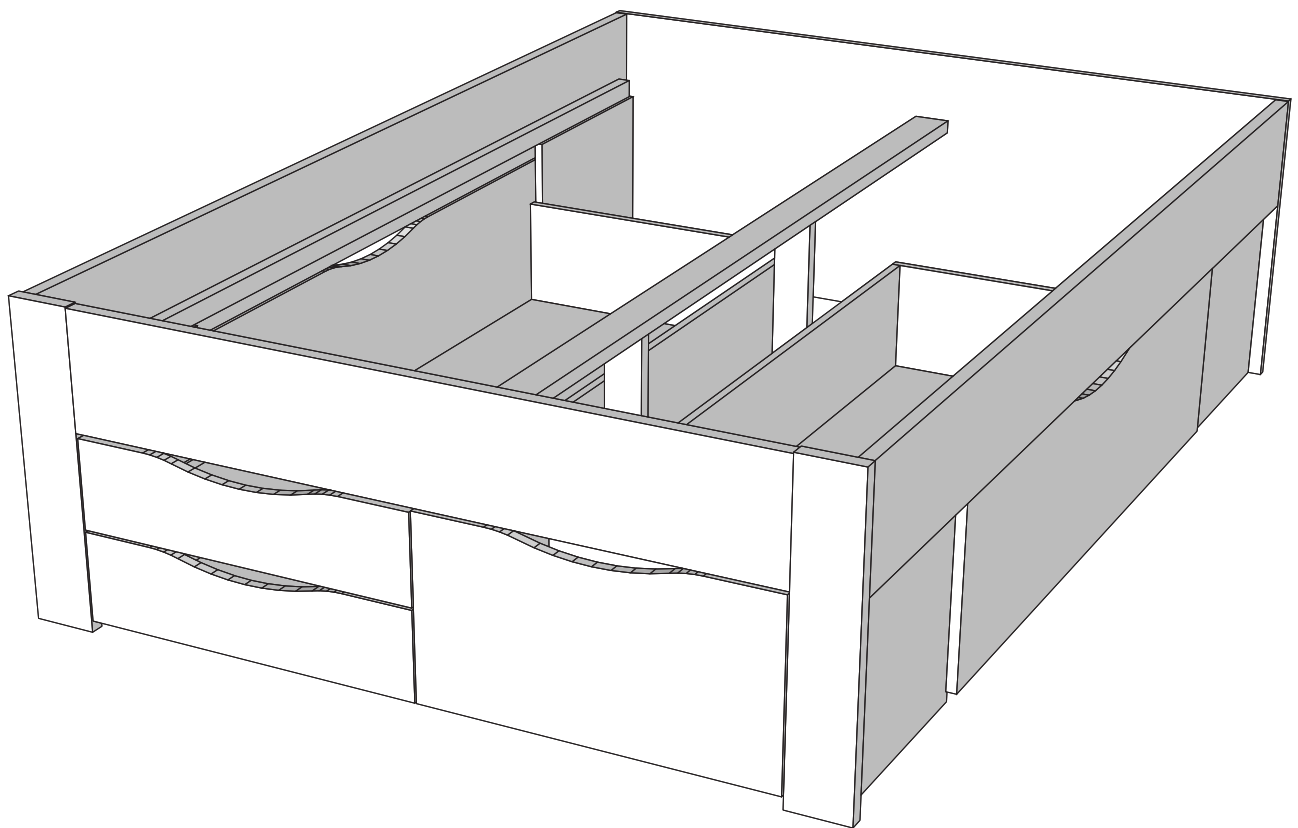

Für Ersatzteilbestellungen und bei Reklamationen bitte nachfolgende Hinweise beachten.



Sehr geehrte(r) Kundin/Kunde.

Sollte ein Teil Ihres bestellten Produktes beschädigt sein oder fehlen, werden wir Ihnen entsprechenden Ersatz liefern. Bitte senden Sie das Produkt nicht zurück.

Bitte füllen Sie die Angaben zum Ersatzteil bzw. Ihrer Reklamation in den unten angegebenen Feldern aus und senden Sie dieses Formblatt ausgefüllt zurück.

Zur Rücksendung können Sie folgende Möglichkeiten wählen:

- per Fax an: +49 -511 -271900
- per e-mail an: reklas@relita.com
- per Post an unsere Rücksendeadresse: Relita Dr.Woite GmbH, Bayernstr . 13, 30855 Langenhagen.

Folgendes bitte ausfüllen:

Name: \_\_\_\_\_

Adresse: \_\_\_\_\_

Telefonnummer: \_\_\_\_\_

e-mail (falls vorhanden): \_\_\_\_\_

Kundennummer (bei Reklamationen immer ausfüllen): \_\_\_\_\_

Artikelnummer: \_\_\_\_\_

Modellbezeichnung: \_\_\_\_\_

Farbe/Beschaffenheit (entsprechendes bitte umkreisen oder unterstreichen):

**natur                      weiß                      geölt                      lackiert**

Benötigte Teile

bitte ergänzen Sie die Bezeichnung die Teilenummer entsprechend der Ihnen vorliegenden Aufbauanleitung

<b>Produkt/Name</b>	<b>Teilenr./Schraubennr.</b>	<b>Bezeichnung/Maße</b>	<b>Anzahl</b>
Futonbett NOAH 140			



Relita Dr. Woite GmbH

Art.No.  
BF54941150-B140  
BF5496085-B140

Stand/version 27.10.2023

**Gebrauchsanleitung: Futonbett NOAH 140**

**Instruction manual: Futon Bed NOAH 140**

Das Bett sollte von 2 Personen aufgebaut werden. (DE)

**Wichtig!**

Bitte lesen Sie die Gebrauchsanleitung mit den Warn- und Sicherheitshinweisen vor dem Aufbau des Bettes sorgfältig durch und bewahren Sie diese danach auf. Die Gebrauchsanleitung beinhaltet darüberhinaus eine Montageanleitung mit einer Stückliste sowie die notwendigen Werkzeuge für einen sicheren Zusammenbau Ihres Bettes. Wichtig ist das alle Teile und das die benötigten Werkzeuge vollständig vorhanden sind.

**Warn- und Sicherheitshinweise:**

Die Sicherheitshinweise des Herstellers sind stets zu befolgen. Zum einzelnen sind diese:

1. Achten Sie beim Zusammenbau des Bettes darauf dass die Verbindungselemente fest angezogen werden. Die Verbindungselemente müssen auch während des Gebrauchs auf Ihren festen Sitz kontrolliert werden.
2. Das Bett darf nicht benutzt werden, wenn ein konstruktives Bauteil beschädigt ist oder fehlt.
3. Folgende Gegenstände dürfen nicht am Bett befestigt oder angehängt werden: Stricke, Schnüre, Kordeln, Gurte, Bänder, etc.. Es besteht Strangulationsgefahr!!
4. Eine ausreichende Raumbelüftung ist notwendig um die Luftfeuchte niedrig zu halten und Schimmelbildung in und um das Bett zu verhindern.

**Pflegehinweis:**

Das Bett darf nur mit einem feuchten Lappen gereinigt werden

- ID. Kennung; Futonbett NOAH 140
- Sperrholz

The bed should be put together by 2 people. (EN)

**Important!**

Please carefully read the instruction manual with the warning and safety instructions before assembling the bed and keep them for future use. The owner's manual also includes assembly instructions with a parts list and the tools required for safe assembly of your bed. It is important to ensure all components and the tools required to be available and complete.

**Warning and safety instructions:**

Please ensure to generally observe the manufacturers assembly instructions. In detail, these are:

1. When assembling the bed make sure that the connecting elements are tightened correctly. The connecting elements must also be monitored for tightness during use.
2. The bed may not be used if any component is missing or broken
3. The following items may not be attached to or hung on the bed ropes, string, cords, straps, belts, etc... Danger of strangulation !!
4. Please note that the room is to be aerated thoroughly to keep the air humidity low and prevent the formation of mould inside and around the bed.

**Care instructions:**

The bed should be cleaned only with a damp cloth

- ID. identifier; Futon Bed NOAH 140
- Plywood



Relita Dr. Woite GmbH

Art.No.  
BF54941150-B140  
BF5496085-B140

versie/version 27.10.2023

**Gebruiksaanwijzing: Futonbed NOAH 140**

**Mode d'emploi du lit futon NOAH 140**

Het bed moet door twee personen opgebouwd worden

(NL)

**Belangrijk!**

Lees alstublieft zorgvuldig de gebruiksaanwijzing met de waarschuwings- en veiligheidsaanwijzingen voor de opbouw van het bed en bewaar deze daarna.

De gebruiksaanwijzing bevat bovendien een montagehandleiding met een onderdelenlijst alsook de noodzakelijke werktuigen voor een veilige assemblage van uw bed. Belangrijk is dat alle delen en het noodzakelijke gereedschap volledig beschikbaar zijn.

**Waarschuwings- en veiligheidsaanwijzingen:**

De montage-instructies van de producent moeten altijd nauwgezet opgevolgd worden. Deze zijn:

1. Let er bij de assemblage van het bed op, dat de verbindingselementen stevig aangezet worden. De verbindingselementen moeten ook gedurende het gebruik op hun stevigheid gecontroleerd worden.
2. Het bed mag niet gebruikt worden als een of ander bouwdeel ontbreekt of gebroken is.
3. Volgende voorwerpen mogen niet aan het bed bevestigd of opgehangen worden: strikken, snoeren, koorden, gordels, banden, enzovoort. Er is wurgingsgevaar!!
4. Voldoende kamerverluchting is noodzakelijk om de luchtvochtigheid laag te houden en schimmelvorming in en om het bed te voorkomen

**Onderhoudstip:**

Het bed mag alleen met een vochtige doek gereinigd worden

- ID-code; Futonbed NOAH 140
- Multiplex

Le lit doit être monté de la part de deux personnes

(FR)

**Important !**

Avant de commencer à monter le lit, veuillez lire attentivement cette instruction d'utilisation qui contient des instructions d'avertissements et de sécurité. Gardez la pour l'utiliser plus tard au cas de besoin.

**Instructions d'avertissements et de sécurité :**

Veillez obligatoirement respecter les instructions données de la part de producteur. Dans les instructions il y en a des détails donnés ci-dessous :

1. Au cours de de montage du lit, assurez-vous que les éléments d'attachement sont bien fixes. La fixation des éléments d'attachements doit être surveiller même au cours de son utilisation
2. Le lit ne pourrait pas être utilisé au cas où il manque des pièces ou il y en a des pièces cassées.
3. Les objets suivants ne doivent pas être accrochés au lit: ex. Cordes, fils, câbles, lacets, ceintures etc. Danger d'étouffement !!
4. Veuillez retenir que l'espace doit être complètement aéré en fonction de maintenir le bas pourcentage de l'humidité et d'empêcher la moisissure à l'intérieur et autour du lit.

**Instructions de maintenance :**

La maintenance du lit doit être faite avec des chiffons humides

- ID indicateur ; lit futon NOAH 140
- Contre-plaqué



Relita Dr. Woite GmbH

Art.No.  
BF54941150-B140  
BF5496085-B140

verzia / verze 27.10.2023

**Návod na použitie: NOAH 140 futon posteľ**

**Návod k použití: NOAH 140 futon lůžko**

Posteľ by mala byť skladaná od dvoch ľudí

(SK)

**Dôležité!**

Pozorne si prečítajte návod na použitie, ktorý obsahuje výstražné a bezpečnostné pokyny, než začnete robiť posteľ. Uložte ho pre budúce použitie.

**Pokyny pre varovanie a bezpečnosť:** Postupujte podľa pokynov výrobcu. Podrobne zahŕňajú:

1. Pri zostavovaní postele, skontrolujte, či sú spojovacie prvky bezpečne pripevnené. Tiež, počas používania sa musí kontrolovať upevnenie upevňovacích prvkov.
2. Posteľ sa nesmie používať, ak jedna z častí chýba alebo je rozbitá.
3. Nasledujúce predmety by sa nemali pripevňovať ani zavesiť na posteli: laná, drôty, káble, remene, pásy atď. Hrozí nebezpečenstvo utopenia!!
4. Upozorňujeme, že miestnosť by mala byť úplne vetraná aby sa udržala nízka úroveň vlhkosti vzduchu, čo by zabránilo tvorbe plesní vo vnútri, a okolo postele.

**Pokyny na údržbu:**

Posteľ by mala byť udržiavaná iba navlhčenou tkaninou

- ID identifikátor; NOAH 140 futon posteľ
- Preglejka

Lůžko by se mělo skládat dva člověka.

(CZ)

**Důležité!**

Přečtěte si pozorně návod k použití který také zahrňuje výstražné a bezpečnostní pokyny, než začnete skládat lůžko. Uložte jej a pro budoucí použití.

**Upozornění a bezpečnostní pokyny:**

- Prosíme, postupujte podle pokynů výrobce. Mezi ně patří zejména:
1. Při sestavování lůžka se ujistěte, že jsou spojovací prvky správně připevněny. Rovněž pevnost spojovacích prvků musí být pozorována při použití taky.
  2. Lůžko nelze použít v případě, že některá z částí chybí nebo je rozbitá.
  3. Na lůžko nesmí být umístěny nebo zavěšeny následující předměty: lana, dráty, kabely, kravaty, popruhy atd. Existuje nebezpečí utopení!!
  4. Upozorňujeme, že místnost by měla být plně větrána aby se udržovala nízká úroveň vlhkosti ve vzduchu, což by zabránilo vzniku plísní uvnitř, a kolem postele.

**Pokyny pro údržbu:**

Lůžko by mělo být udržováno pouze vlhkým hadříkem

- ID identifikátor; NOAH 140 futon lůžko
- Překližka



Relita Dr. Woite GmbH

Art.No.  
BF54941150-B140  
BF5496085-B140

változat / verzija 27.10.2023

Használati utasítás: NOAH 140 futon ág

Upute za uporabu: Futon krevet NOAH 140

Az ág összeszerelési folyamatát célszerű kettő embernek elvégeznie.

(HU)

#### Fontos!

Kérjük, az ág összeszerelése előtt szíveskedjen elolvasni a használati útmutatót, melyből tudomást szerezhet az ág szakszerű összeszerelési folyamatáról és egyben figyelmeztetést a biztonságos használattal kapcsolatban. Őrizze meg a használati útmutatót, mert a jövőben még szüksége lehet rá.

**Figyelmeztetési és biztonsági előírások** Kérjük, feltétlenül olvassa el a gyártó által megadott használati utasításokat A használati útmutató, többek között, a következőket tartalmazza részletesebben:

1. Az ág összeszerelési folyamata során, győződjön meg az ág összekötő részeinek biztonságos és szakszerű összeillesztéséről. Célszerű az összekötő részeket a jövőben is (a használati időtartam alatt), folyamatosan ellenőrizni.
2. Az ágyat nem lehet használni ha annak valamely része hiányos vagy esetleg törött.
3. Az ágyra tilos a következő tárgyakat ráilleszteni: kötelek, kábelek, fűzők, szíjak stb. ! Fennáll az esetleges fuldoklási veszély kockázata!
4. Az ág mögötti esetleges penészképződés és a z ág körülötti nem kívánatos kellemetlen szagok megelőzése érdekében, kérjük, biztosítsa a helység megfelelő szellőzését, egyidejűleg megfelelő szintű páratartalmát is.

#### Kezelési útmutatás:

Az ágyat kizárólag nedves ronggyal tisztítjuk

- ID azonosító; NOAH 140 futon ág
- Furnér

Krevet trebaju sastavljati dvije osobe.

(HR)

#### Važno!

Molimo Vas da pažljivo pročitate upute za upotrebu, koje sadrže i upute upozorenja i sigurnosti prije početka sastavljanja kreveta. Čuvajte ih za sljedeću upotrebu.

#### Upute upozorenja i sigurnosti:

Molimo Vas da obavezno slijedite instrukcije prizvođača. Detaljnije, tu je uključeno:

1. Pri sastavljanju kreveta, budite sigurni da su elementi za povezivanje pravilno pričvršćeni. Isto tako, pričvršćenost elemenata za povezivanje treba nadzirati i prilikom upotrebe.
2. Krevet se ne može koristiti ako nedostaje neki dio ili ako je razbijen.
3. Sljedeći predmeti ne smiju se stavljati ili vješati na krevet konop, žice, kabel, vezice, pojas... Postoji opasnost od davljenja !!
4. Molimo Vas da zapamtite da prostorija treba biti potpuno prozračena radi održavanja niske razine vlage u zraku, čime bi se zaustavilo stvaranje plijesni unutar, i oko kreveta.

#### Upute za održavanje:

Krevet treba održavati samo vlažnom krpom.

- ID identifikator ; Futon krevet NOAH 140
- Iverica

**DE** Montageanleitung Futonbett **NOAH 140**  
**EN** Assembly instructions Futon bed **NOAH 140**  
**NL** Montage-instructies Futonbed **NOAH 140**  
**FR** Instructions de montage Lit futon **NOAH 140**

**SK** Montážne pokyny Futon posteľ **NOAH 140**  
**CZ** Návod k montáži Futon lůžko **NOAH 140**  
**HU** Szerelési útmutató Futon ágy **NOAH 140**  
**HR** Upute za montažu Futon krevet **NOAH 140**

Date 27.10.2023

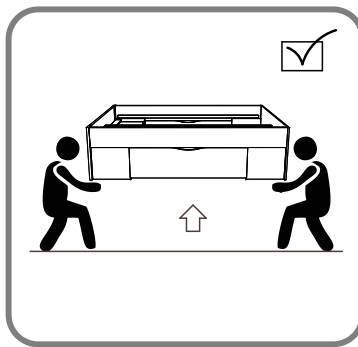
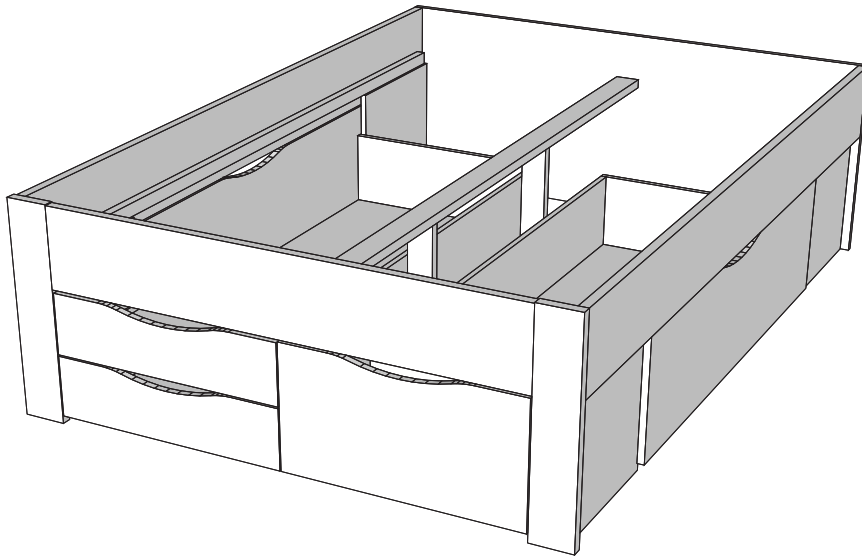

**DE Wichtiger Hinweis:**  
Bett nicht schieben, nur angehoben umstellen.

**EN Important information:**  
Do not shove the bed, move it only by lifting.

**NL Belangrijke opmerking:**  
Het bed niet schuiven, alleen verplaatsen door opheffen.

**FR Information importante:**  
Ne pas pousser le lit, il faut le porter pour déplacer.

**SK Dôležitá informácia:**  
Posteľ neskladajte, pohybujte iba zdvíhaním.

**CZ Důležitá informace:**  
Nevystrkujte postel, pohybujte pouze zvedáním.

**HU Fontos információ:**  
Ne lökd be az ágyat, csak emeléssel mozgassa.





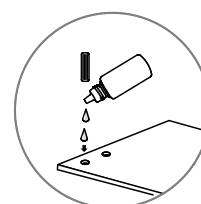
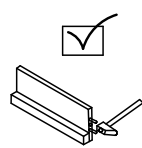
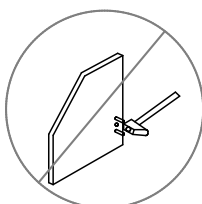
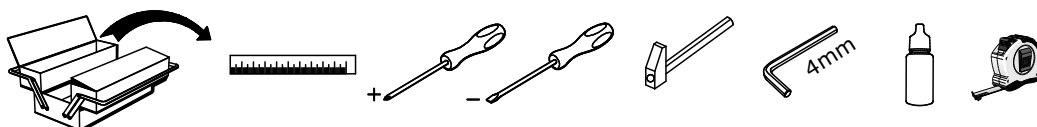
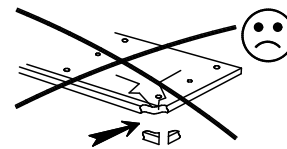
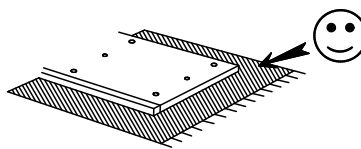
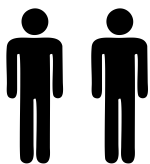





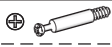

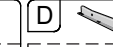

**HR Važna informacija:**  
Ne gurajte krevet, pomičite ga samo podizanjem.

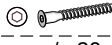
1:30'

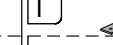
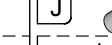

# FUTONBETT NOAH 140

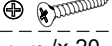
<b>DE</b> Anleitungen für die Montage	<b>EN</b> Instructions for the assembly	<b>NL</b> Instructies voor de montage	<b>FR</b> Instructions de montage
<b>SK</b> Pokyny na montáž	<b>CZ</b> Pokyny pro montáž	<b>HU</b> Utasítások az összeszereléshez	<b>HR</b> Upute za sastavljanje

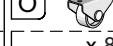
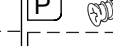
<b>A</b>  x 16	<b>B</b>  $\varnothing 15 \times 12.5 /$ x 16	<b>C</b>  $\varnothing 8 \times 35$ x/46	<b>D</b>  CR / x 3	<b>D</b>  DL / x 3	<b>D</b>  CL / x 3	<b>D</b>  DR / x 3
<b>E</b>  M 7 x 50 /x 28	<b>F</b>  M 7 x 70 /x 2	<b>G</b>  $\varnothing 4 \times 35$ /x 8	<b>H</b>  $\varnothing 3.5 \times 16$ /x 62	<b>I</b>  30 x 30 /x 2	<b>J</b>  glue /x 2	<b>K</b>  x 1
<b>L</b>  $\varnothing 4 \times 40$ /x 20	<b>M</b>  25x25x130mm X/2	<b>N</b>  50 x 40 /x 2	<b>O</b>  x 8	<b>P</b>  6.3x13 / x 14		

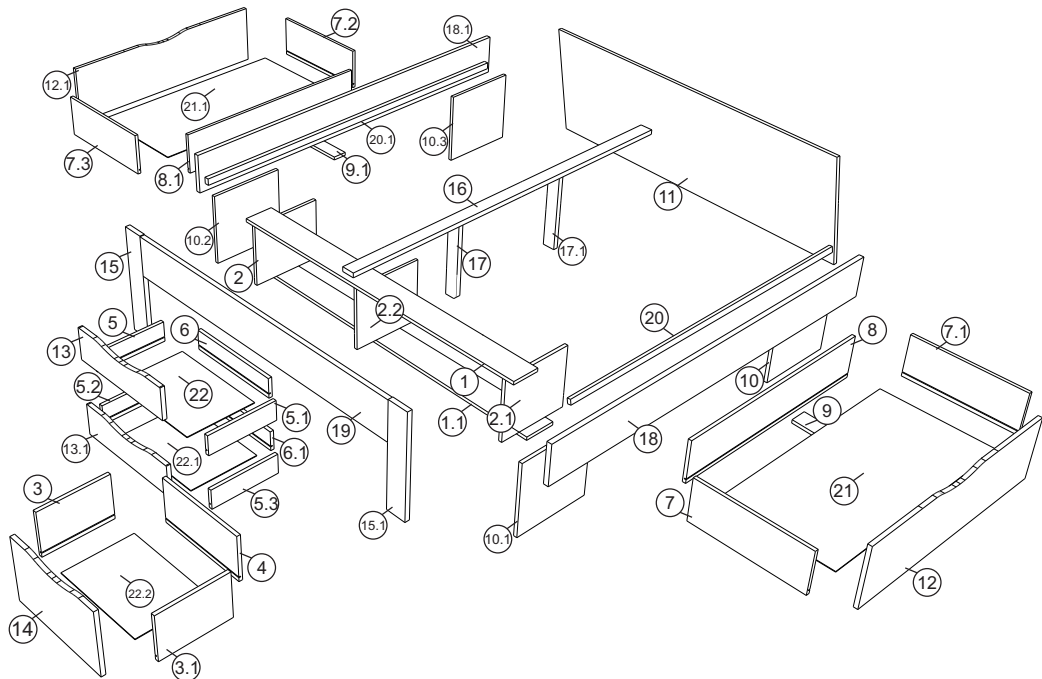

Stückliste / List of Materials / Stuklijst / Liste des matériaux  
Zoznam materiálov / Seznam materijala / Anyagok listája / Popis materijala

No	QTY	Dimensions / mm	Box *
1	1	1368x160x16	1/3
1.1	1	1368x160x16	1/3
2	1	334x380x16	3/3
2.1	1	334x380x16	3/3
2.2	1	334x380x16	1/3
3	1	350x190x16	3/3
3.1	1	350x190x16	3/3
4	1	552x190x16	3/3
5	1	350x100x16	2/3
5.1	1	350x100x16	2/3
5.2	1	350x100x16	2/3
5.3	1	350x100x16	2/3
6	1	552x100x16	2/3
6.1	1	552x100x16	2/3
7	1	600x190x16	2/3
7.1	1	600x190x16	2/3

No	QTY	Dimensions / mm	Box *
7.2	1	600x190x16	3/3
7.3	1	600x190x16	3/3
8	1	1156x190x16	2/3
8.1	1	1156x190x16	2/3
9	1	582x100x16	3/3
9.1	1	582x100x16	3/3
10	1	400x380x16	1/3
10.1	1	400x380x16	1/3
10.2	1	400x380x16	1/3
10.3	1	400x380x16	1/3
11	1	1452x560x16	2/3
12	1	1215x325x16	2/3
12.1	1	1215x325x16	2/3
13	1	611x161x16	3/3
13.1	1	611x161x16	3/3
14	1	611x326x16	3/3

No	QTY	Dimensions / mm	Box *
15	1	110x560x25	2/3
15.1	1	110x560x25	2/3
16	1	2000x52x18	1/3
17	1	407x52x18	3/3
17.1	1	407x52x18	3/3
18	1	2000x207x25	1/3
18.1	1	2000x207x25	1/3
19	1	1236x209x25	1/3
20	1	1930x35x25	1/3
20.1	1	1930x35x25	1/3
21	1	1172x595x3.2	2/3
21.1	1	1172x595x3.2	2/3
22	1	565x348x3.2	2/3
22.1	1	565x348x3.2	2/3
22.2	1	565x348x3.2	2/3

\* DE Teileverteilung per Karton / EN Distribution of parts by box / NL Distributie van onderdelen per doos / FR Répartition des pièces par boîte  
SK Rozdelenie častí po škatuli / CZ Rozdělení dílů v krabici / HU Az alkatrészek megosztása dobozok szerint / HR Distribucija dijelova po kutiji

\*\* DE Matratze / EN Mattress / NL Matras / FR Matelas / SK Matrace / CZ Matrace / HU Matrac / HR Madrac



# FUTONBETT NOAH 140

**1** | L ⊕ 20 st. |     10Min. |    glue | **Positioning and securing of the bed side slats**

**1**

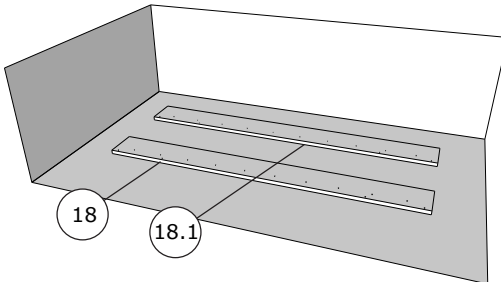

Put the side panels of the bed on ground facing backside and make sure that there is nothing below the panel

**2**

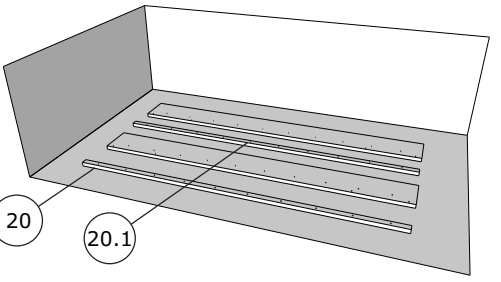

Put the left panel of the bed on ground facing frontside and make sure that there is nothing below the panel

**3**

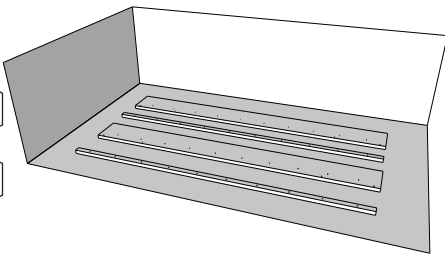

Make sure that left side panel of the bed and right side panel of the bed are clean from dust, dirt and oil.

**4**

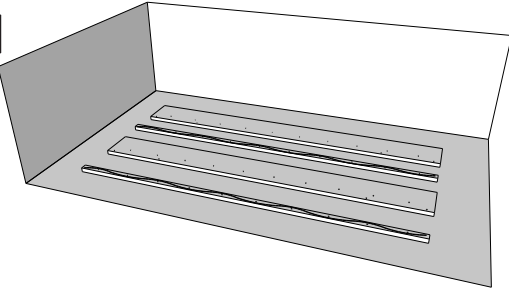

Make sure that all panels that you need to apply glue to are clean from dust, dirt and oil and then apply glue on them.

**5**

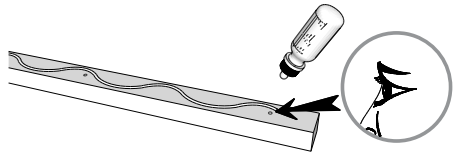

Make sure that you apply the glue from right side and wait 5min. for glue to cure.

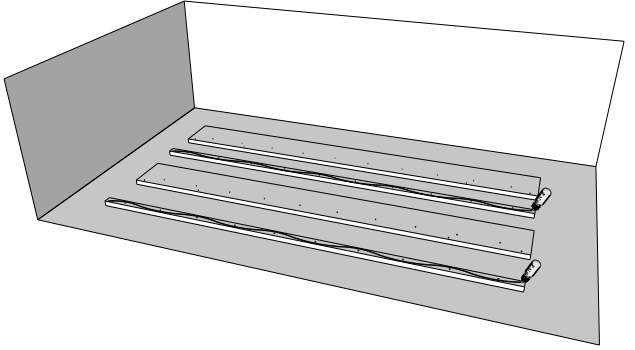

**6**

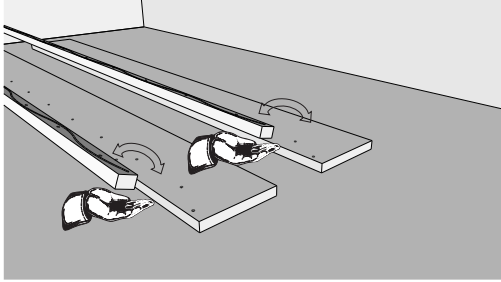

Gently turn over all panels that you apply glue on and place them on right position.



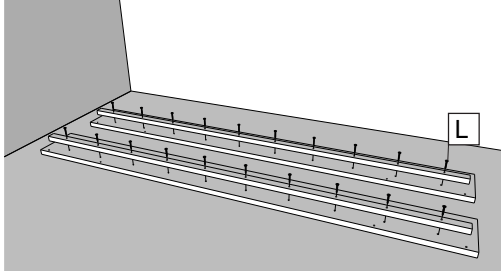

**7**



Gently apply pressure on the surface of the panels and secure them with screws.  
**IMPORTANT:**  
Full cure time of the glue is 12 hours!



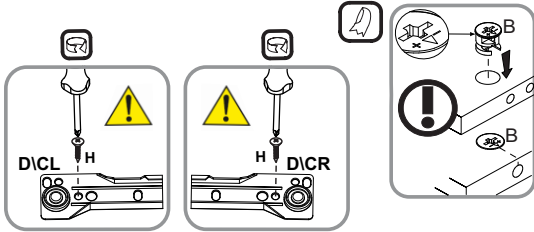
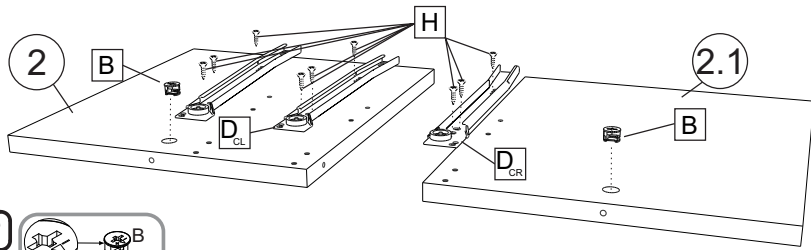

# FUTONBETT NOAH 140

**2**

B		2 st.
H		9 st.
D		1 st.
D		2 st.



**3**

B		2 st.
D		2 st.
D		1 st.
H		9 st.

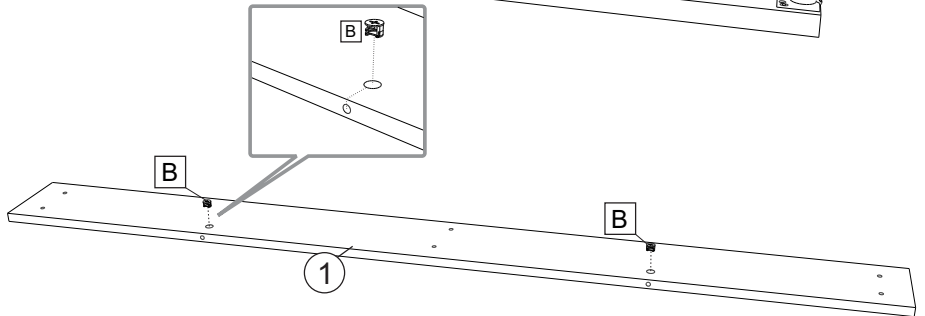
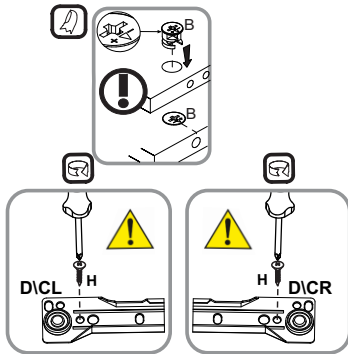
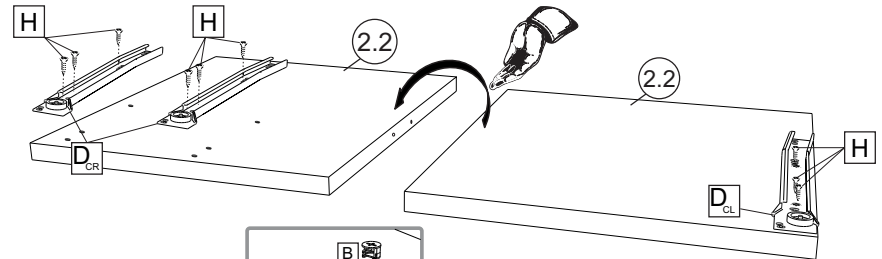



**4**

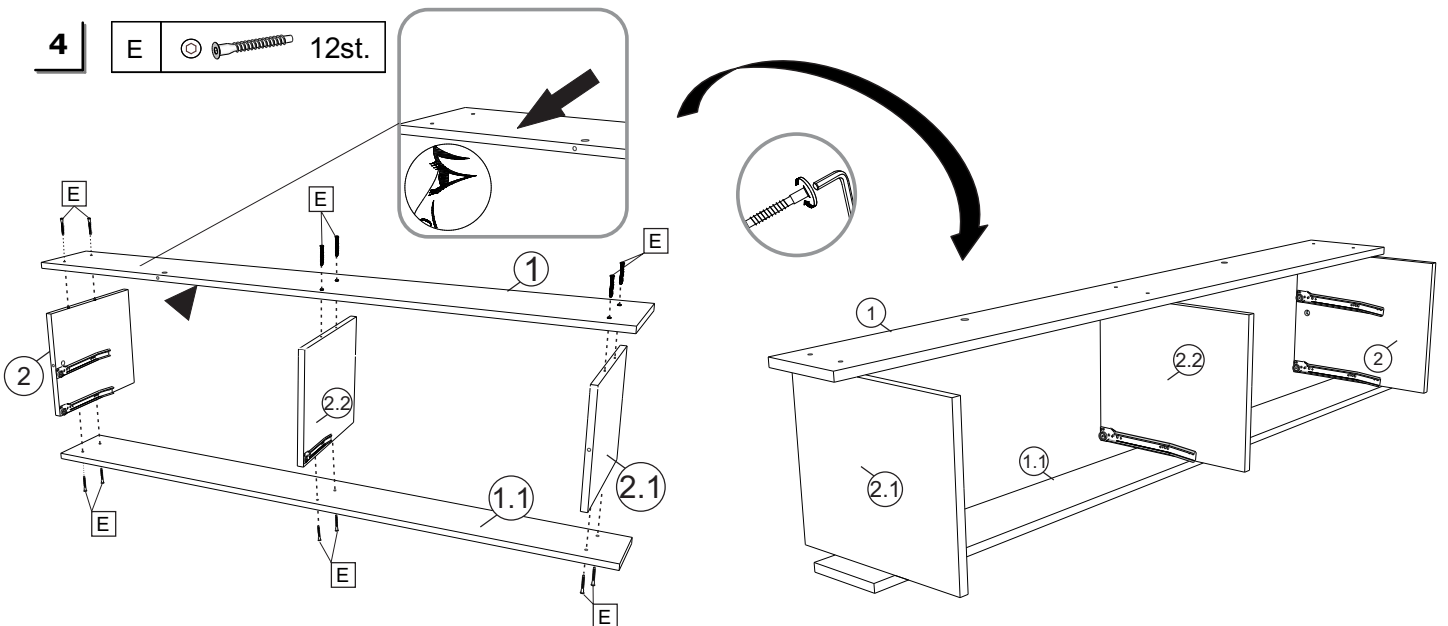

E		12 st.
---	---	--------



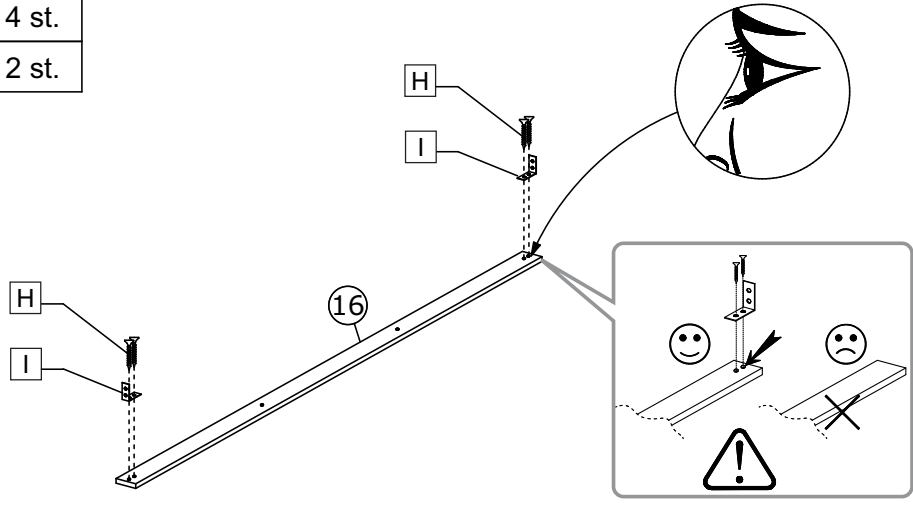

# FUTONBETT NOAH 140

5	H		4 st.
	I		2 st.

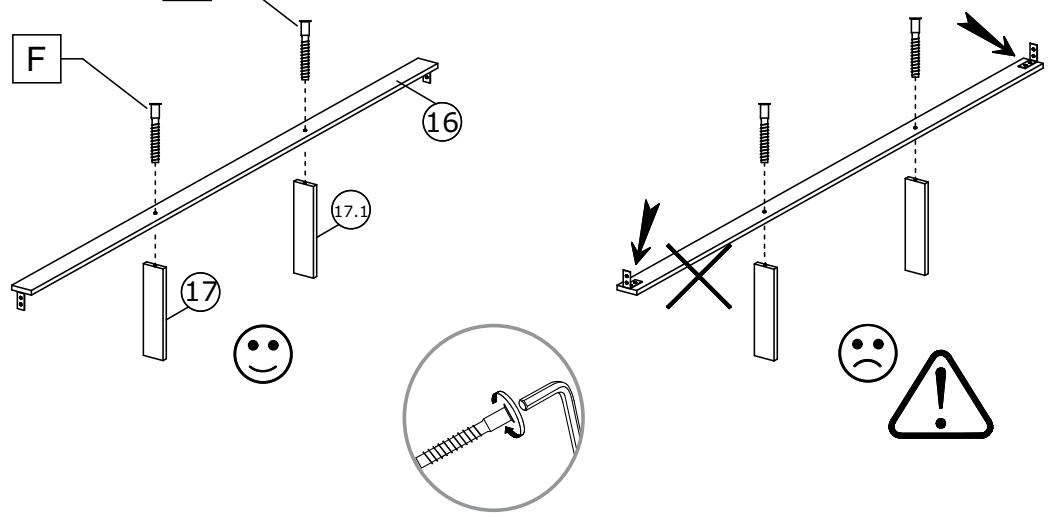

6	F		2 st.
	F		





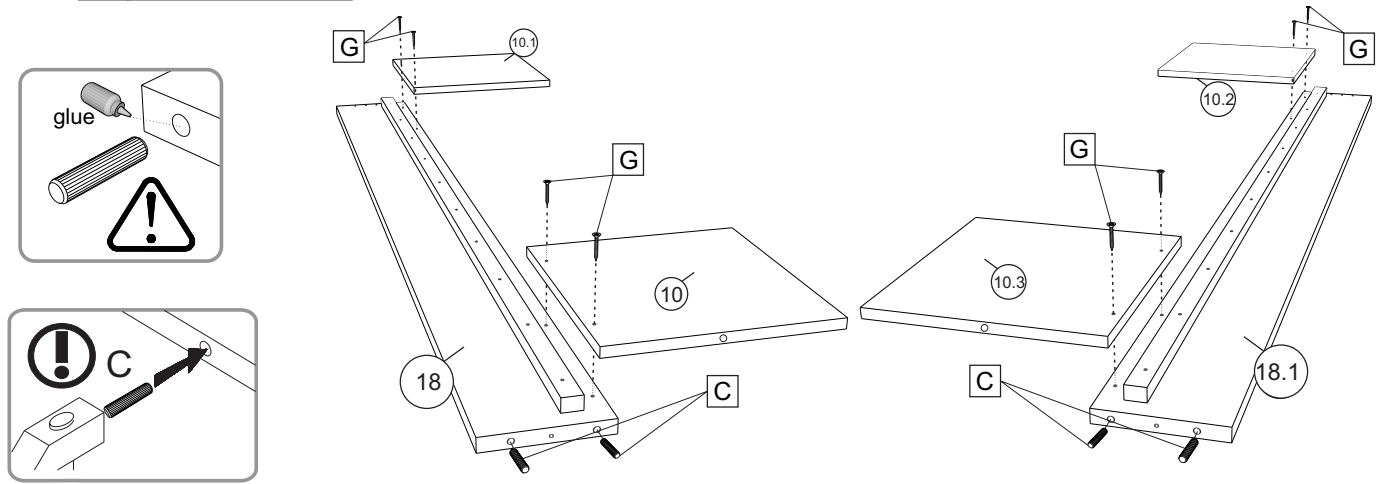

7	G		8 st.
	C		4 st.



# FUTONBETT NOAH 140

**8**

A		2 st.
C		6 st.
H		4 st.
N		2 st.

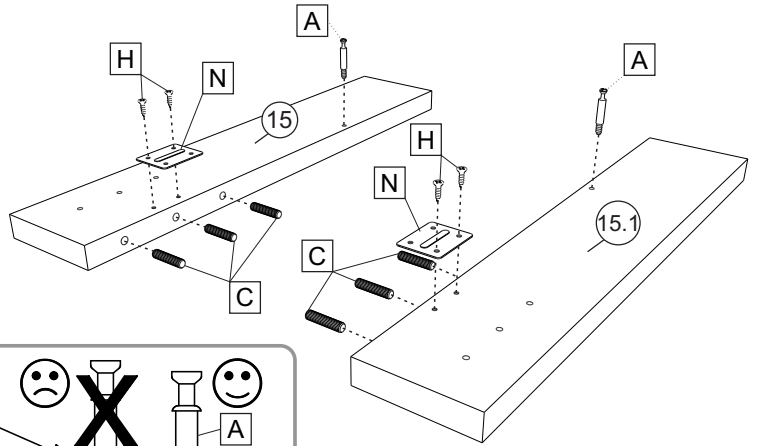
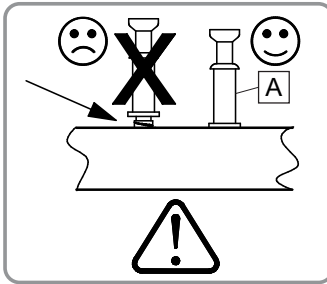
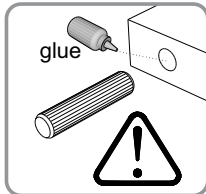
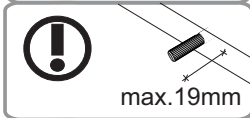
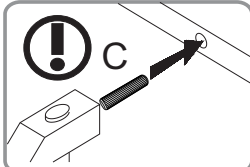

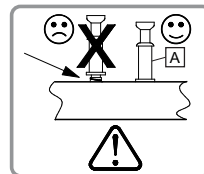
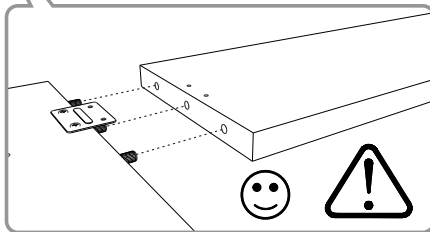
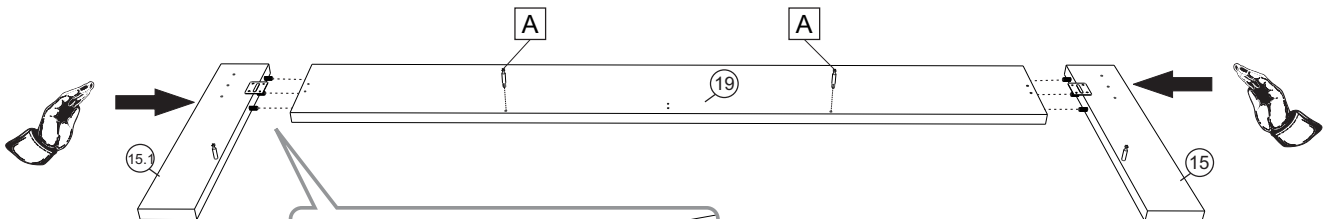

**9**

A		2 st.
---	---	-------



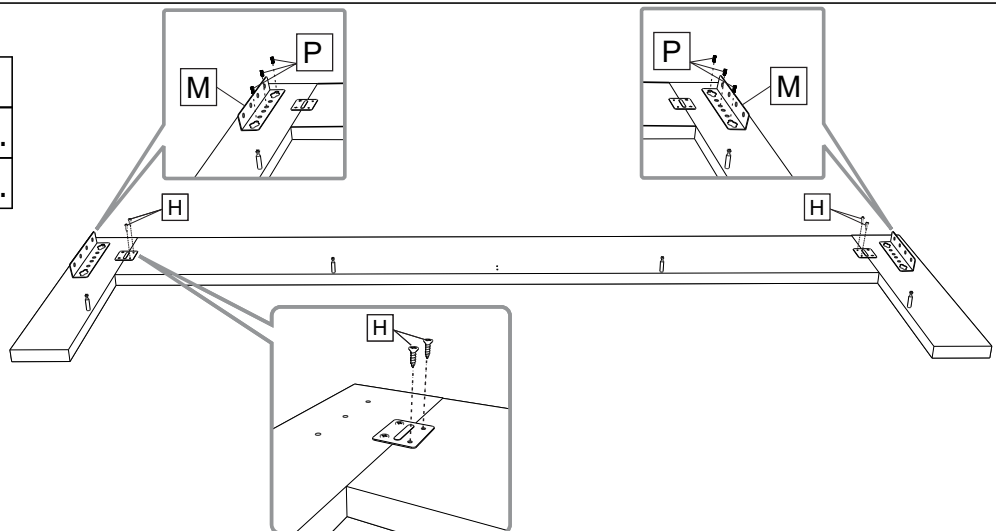

**10**

H		4 st.
M		2 st.
P		6 st.

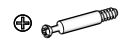

# FUTONBETT NOAH 140

**11**

A		6 st.
B		6 st.
C		20 st.

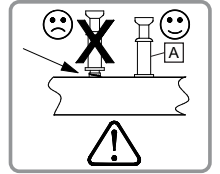
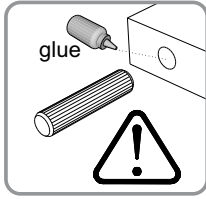
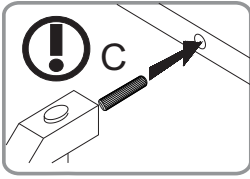
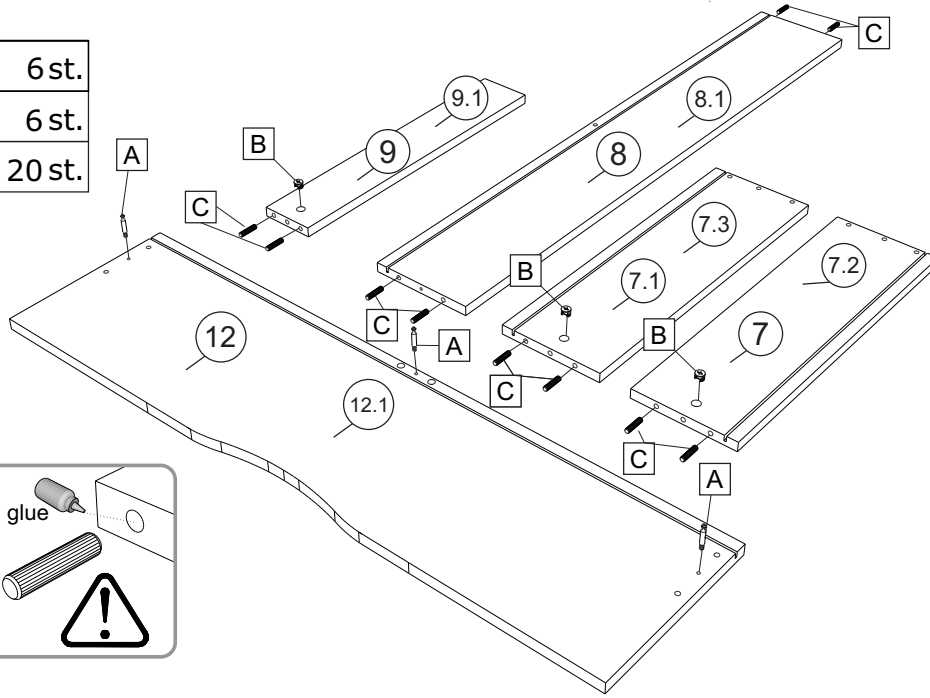

**12**

E		2 st.
---	---	-------

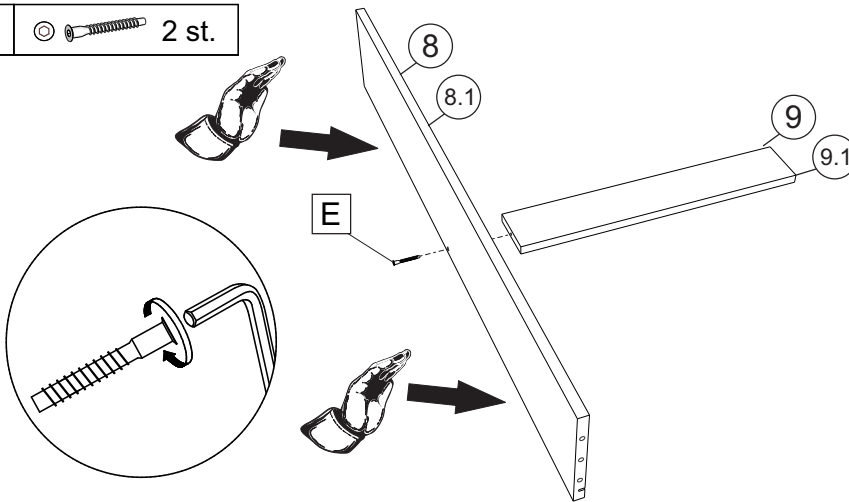

**13**

E		4 st.
---	---	-------

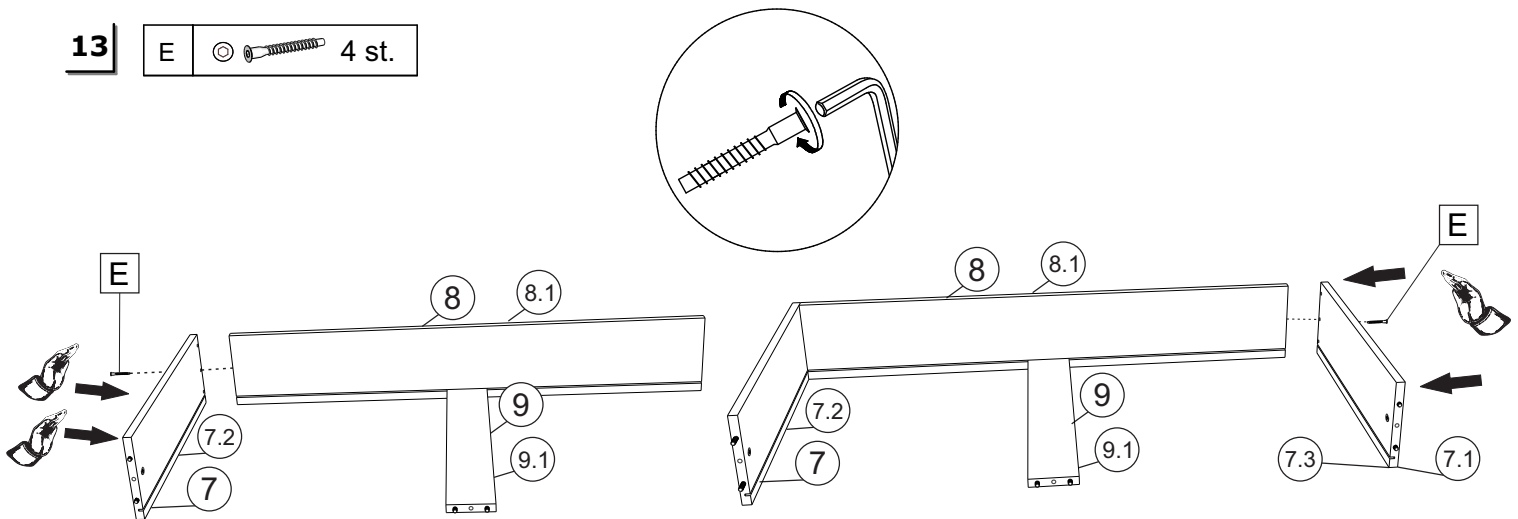

# FUTONBETT NOAH 140

14

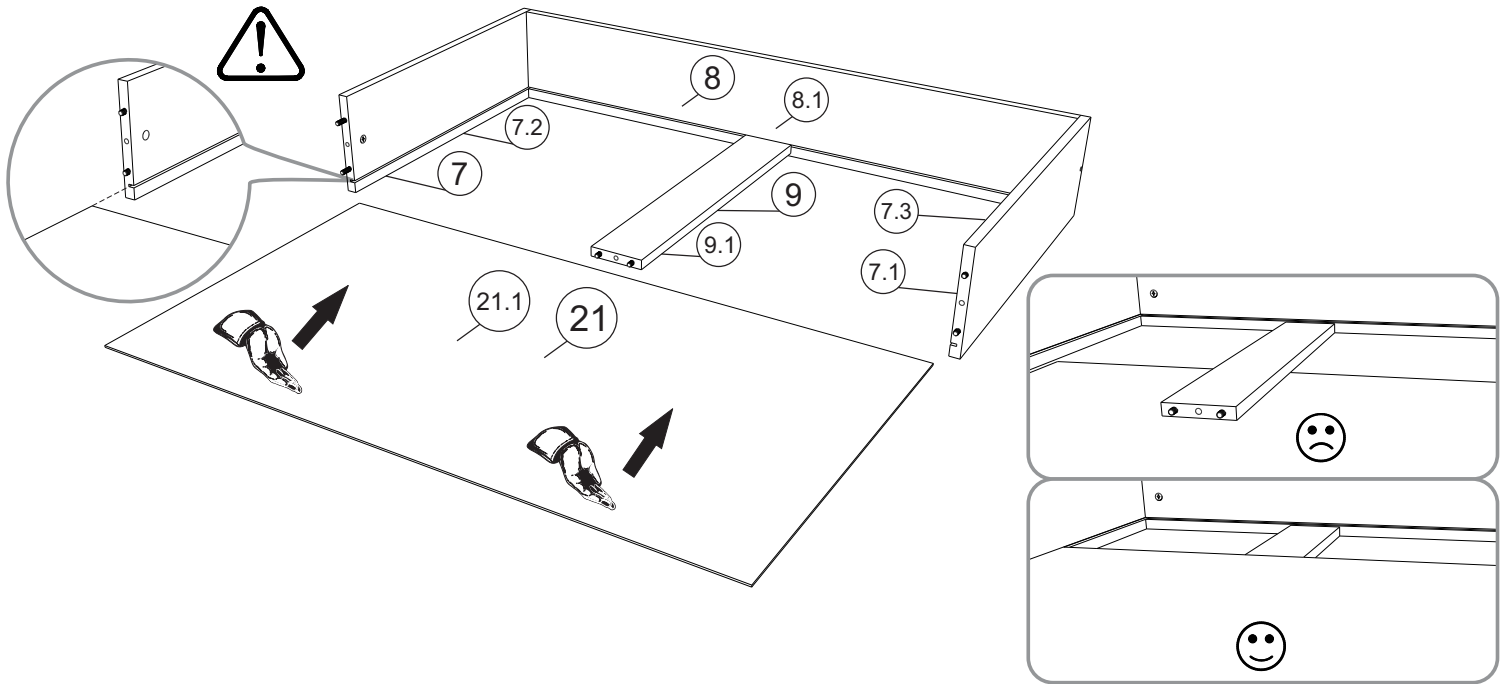

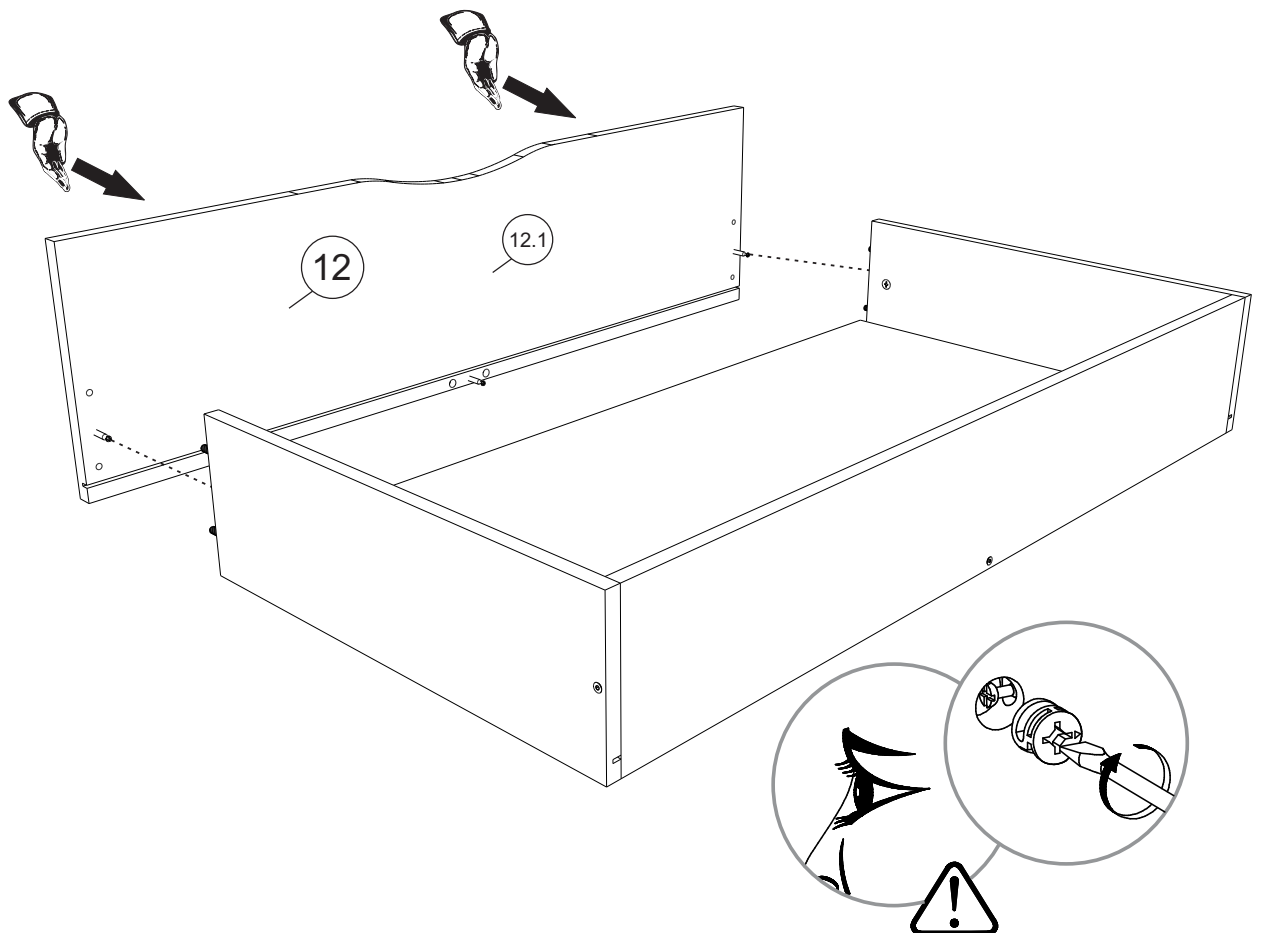

15





# FUTONBETT NOAH 140

**16**

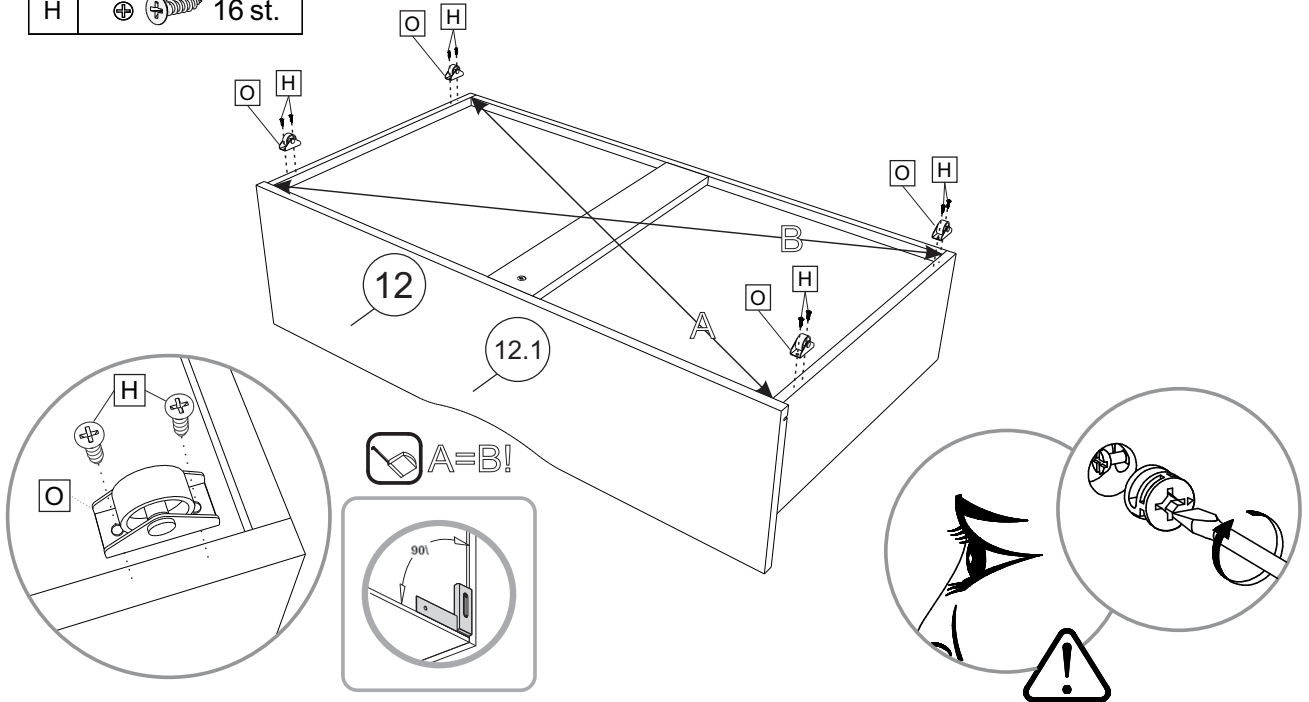
O		8 st.
H		16 st.



**17**

A		4 st.
B		4 st.
C		8 st.

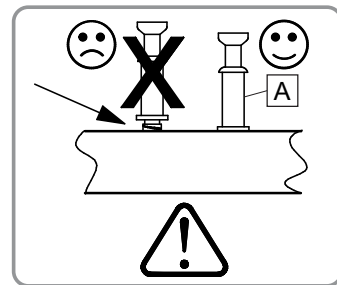
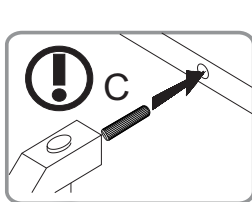
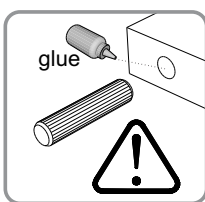
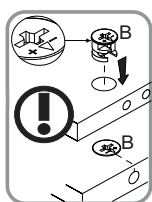
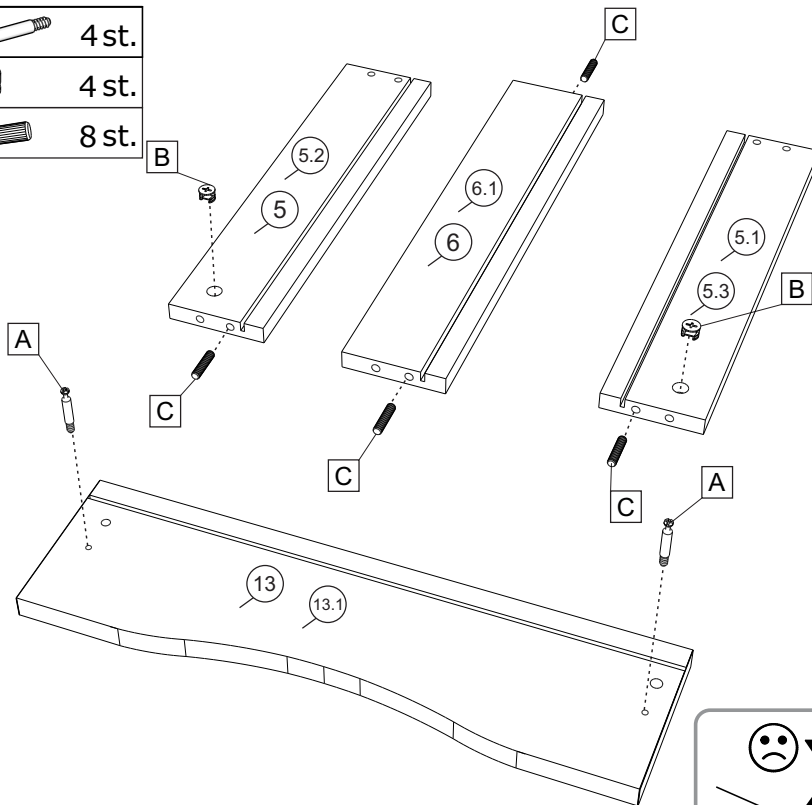

# FUTONBETT NOAH 140

18

E  4 st.

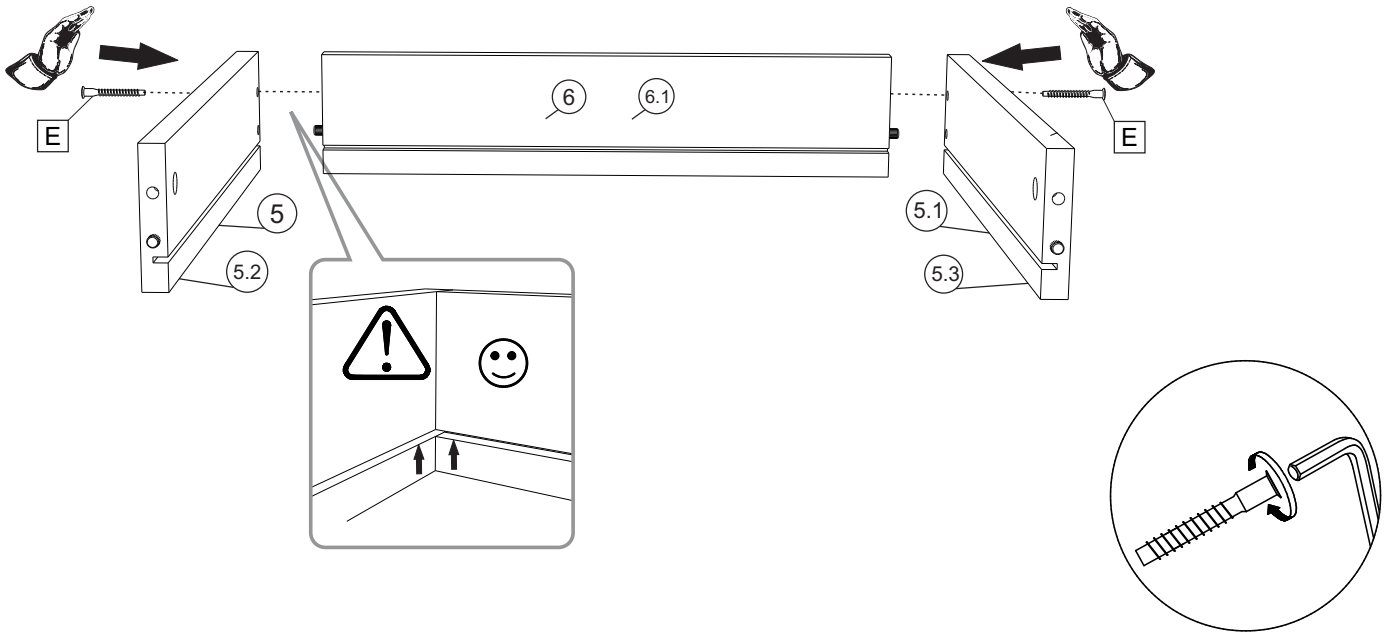

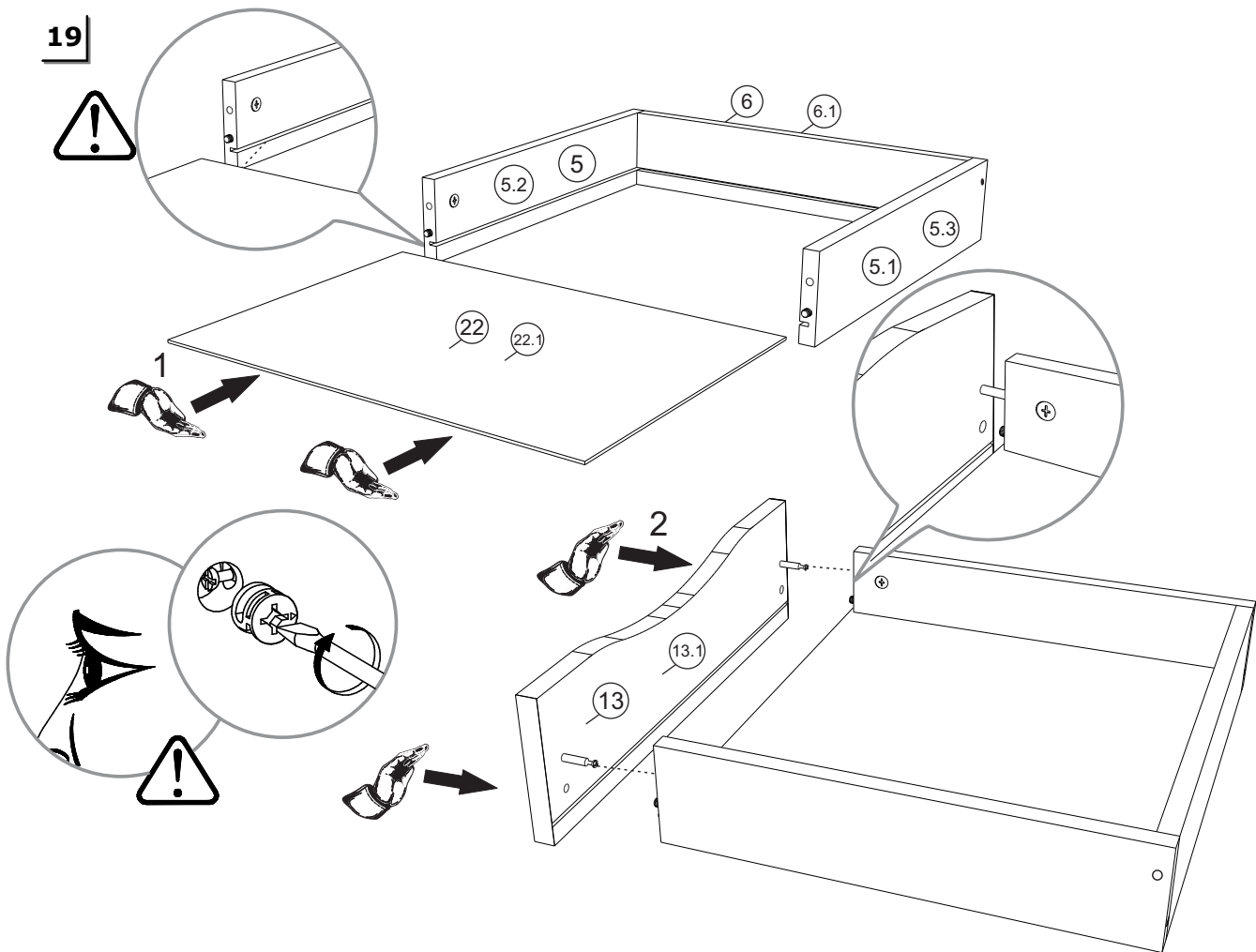

19





# FUTONBETT NOAH 140

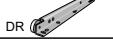

**20**

D		2 st.
D		2 st.
H		8 st.

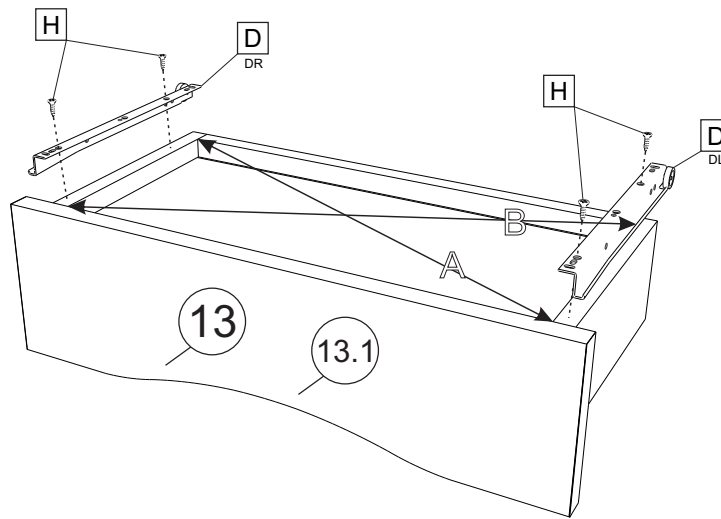
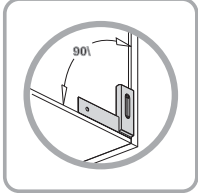
 A=B!



**21**

A		2 st.
B		2 st.
C		8 st.

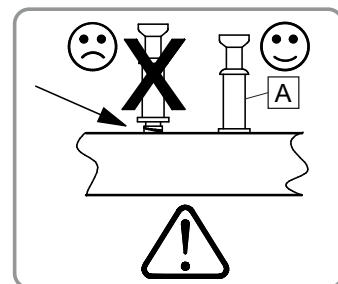
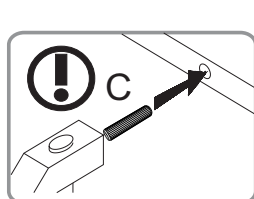
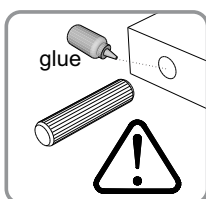
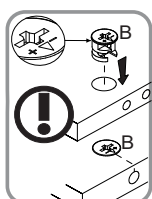
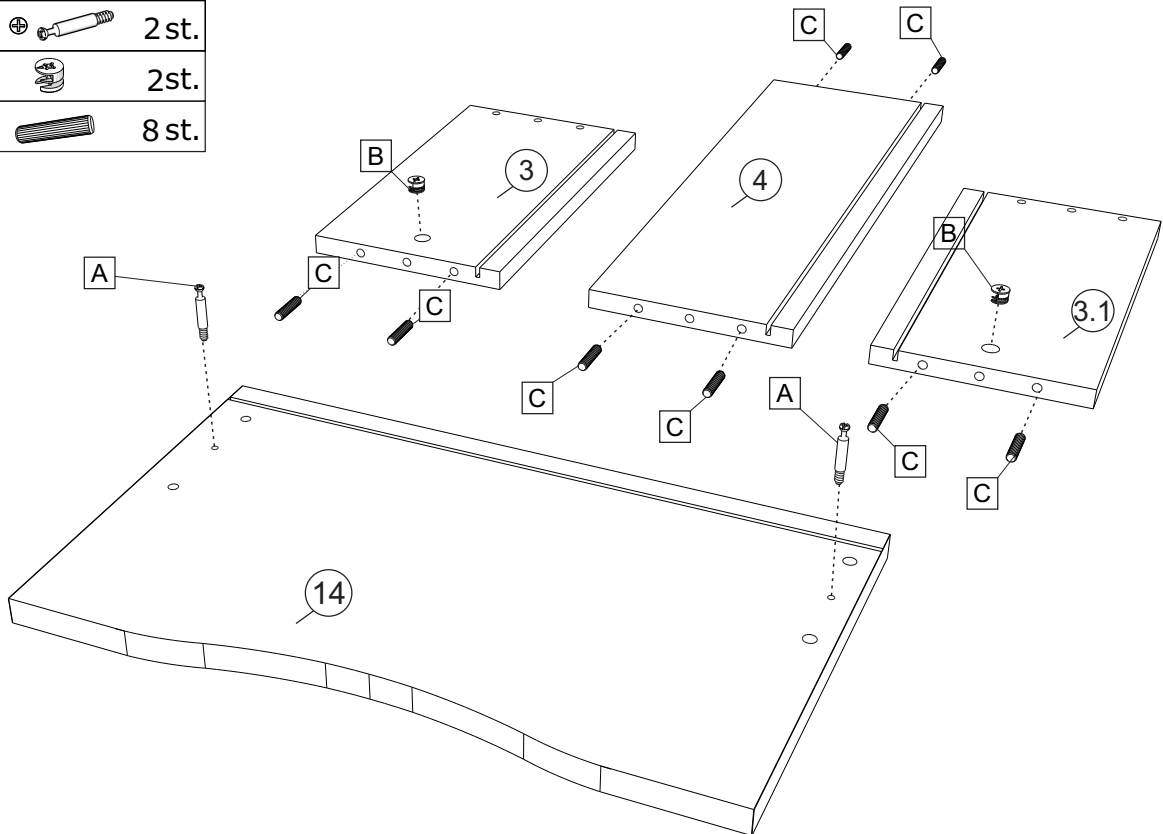

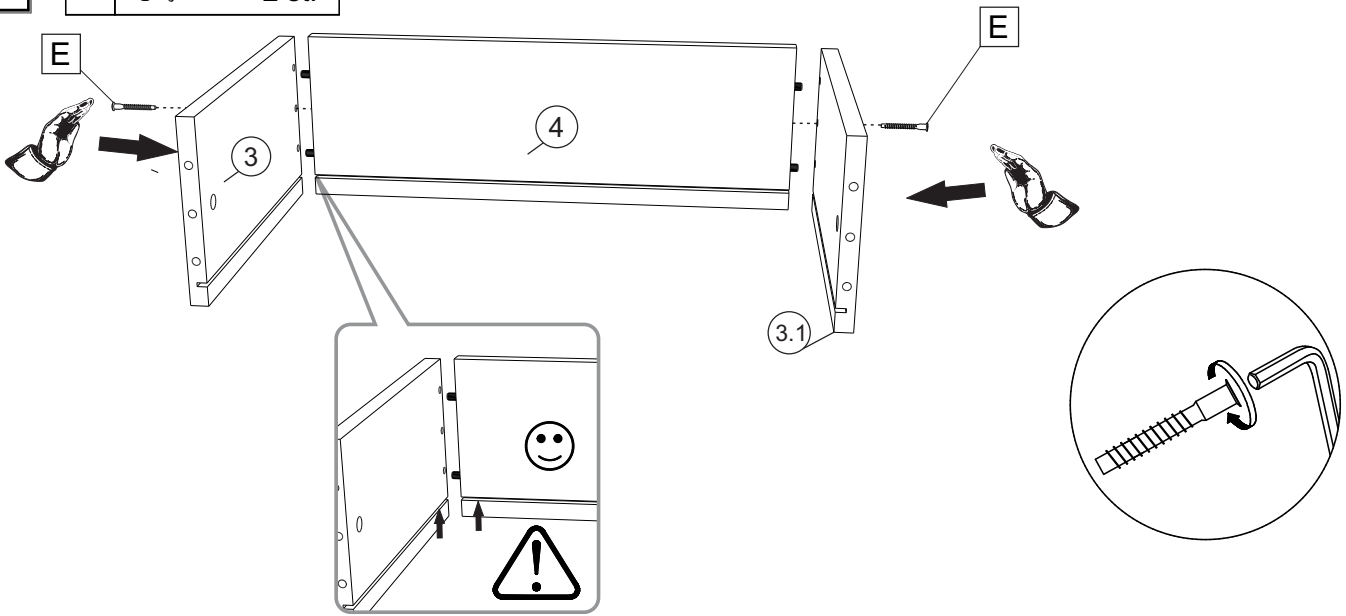

# FUTONBETT NOAH 140

**22** E  2 st.



**23**

D		DL	1 st.
D		DR	1 st.
H			4 st.

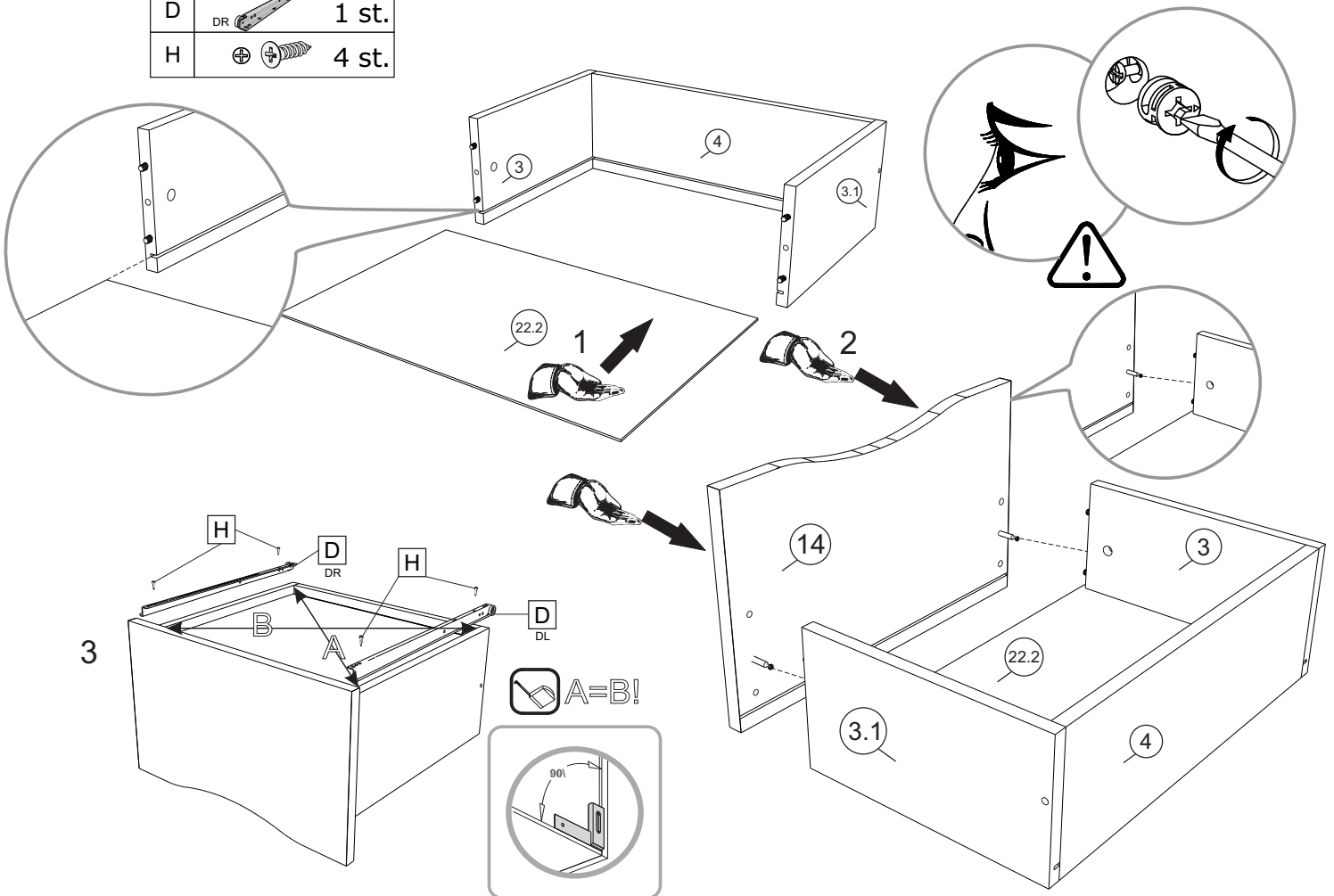

# FUTONBETT NOAH 140

24

E  4 st.

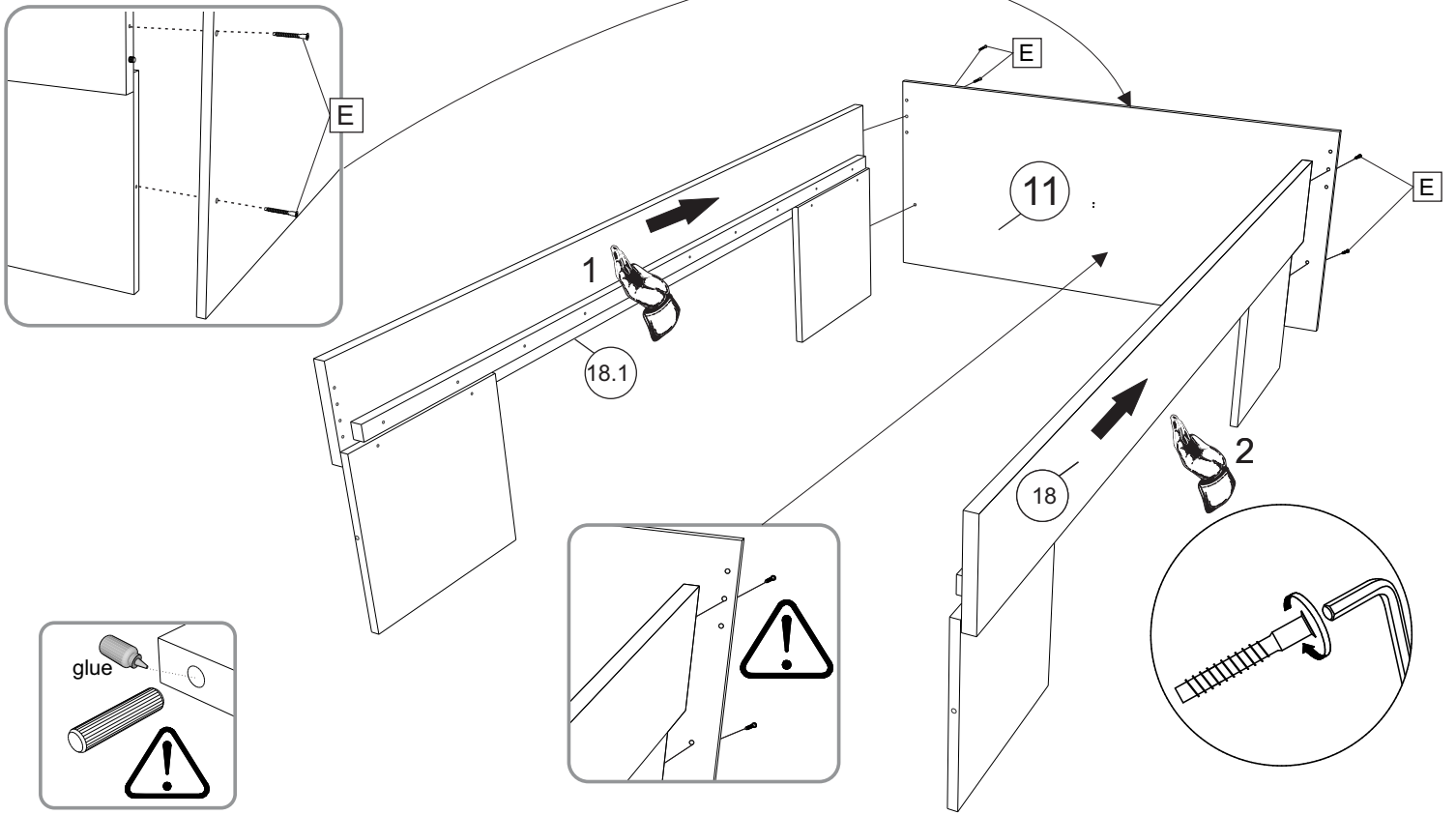

25

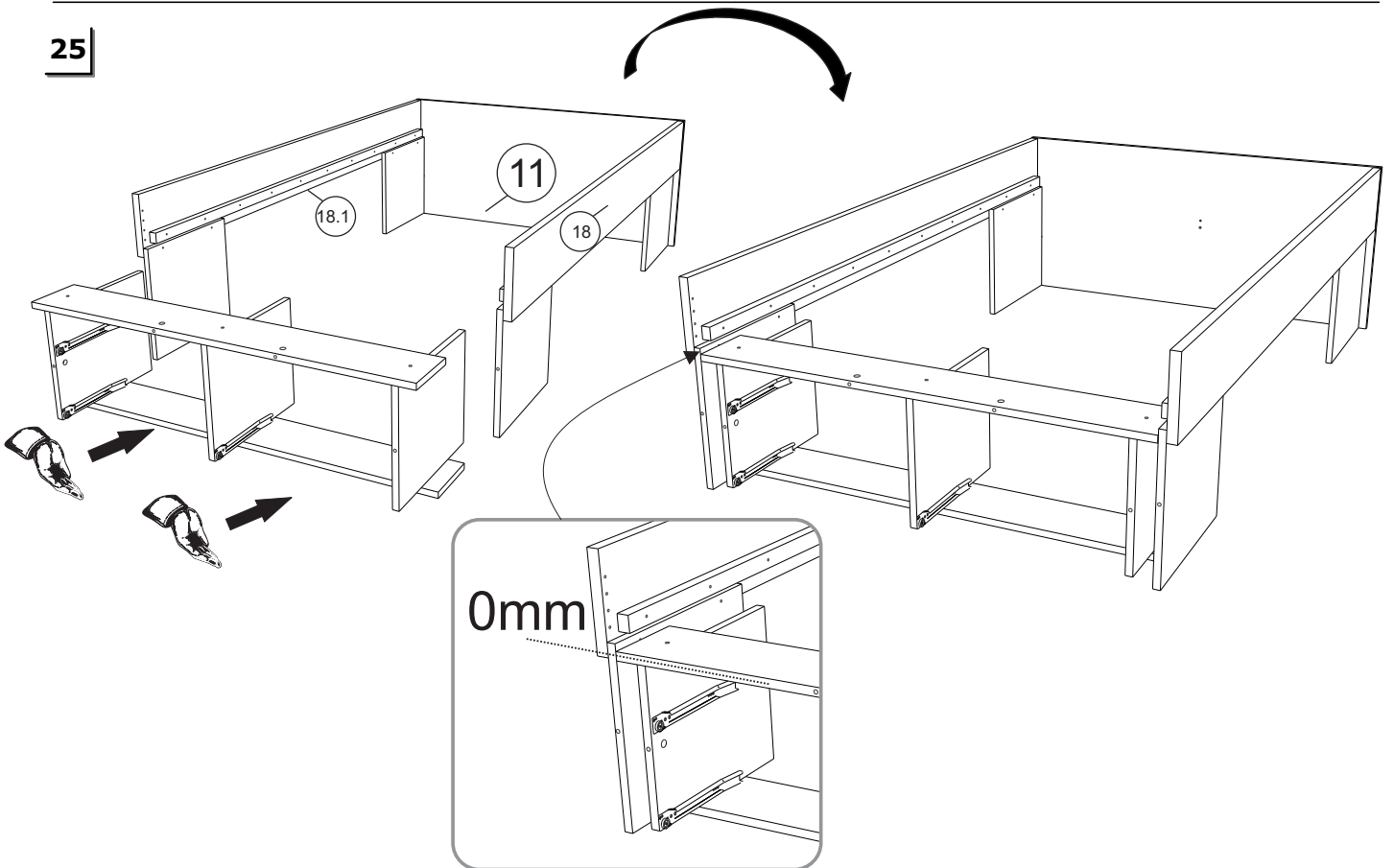



# FUTONBETT NOAH 140

26

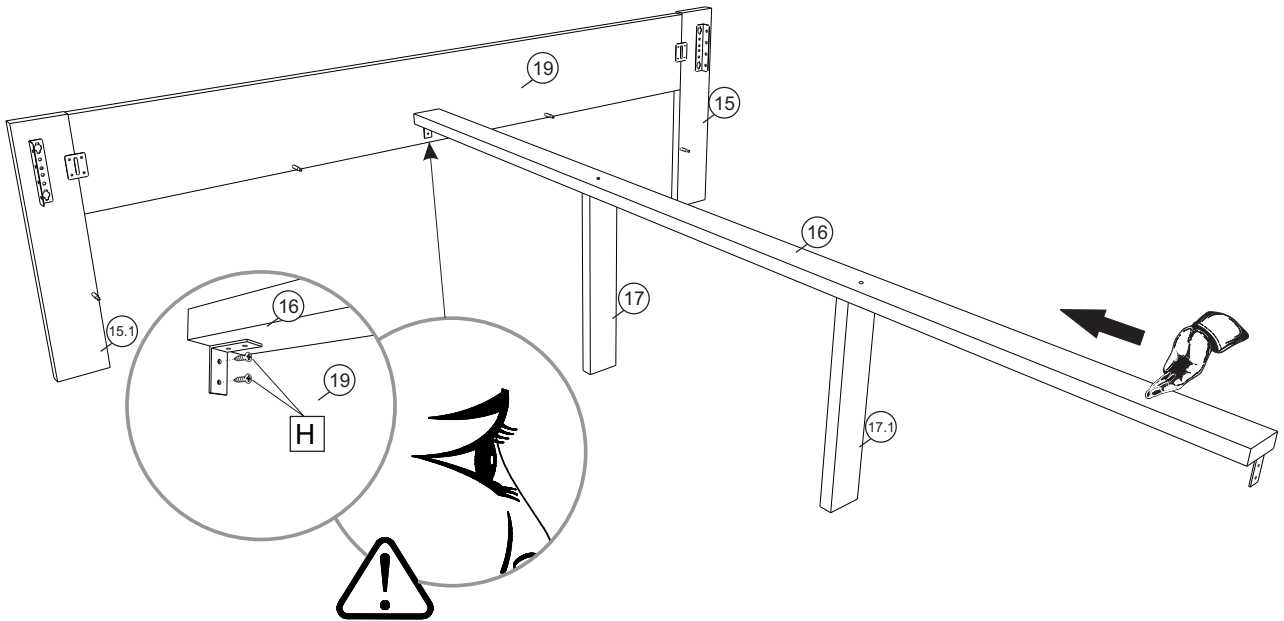
H		2 st.
---	---	-------



27

H		2 st.
P		8 st.

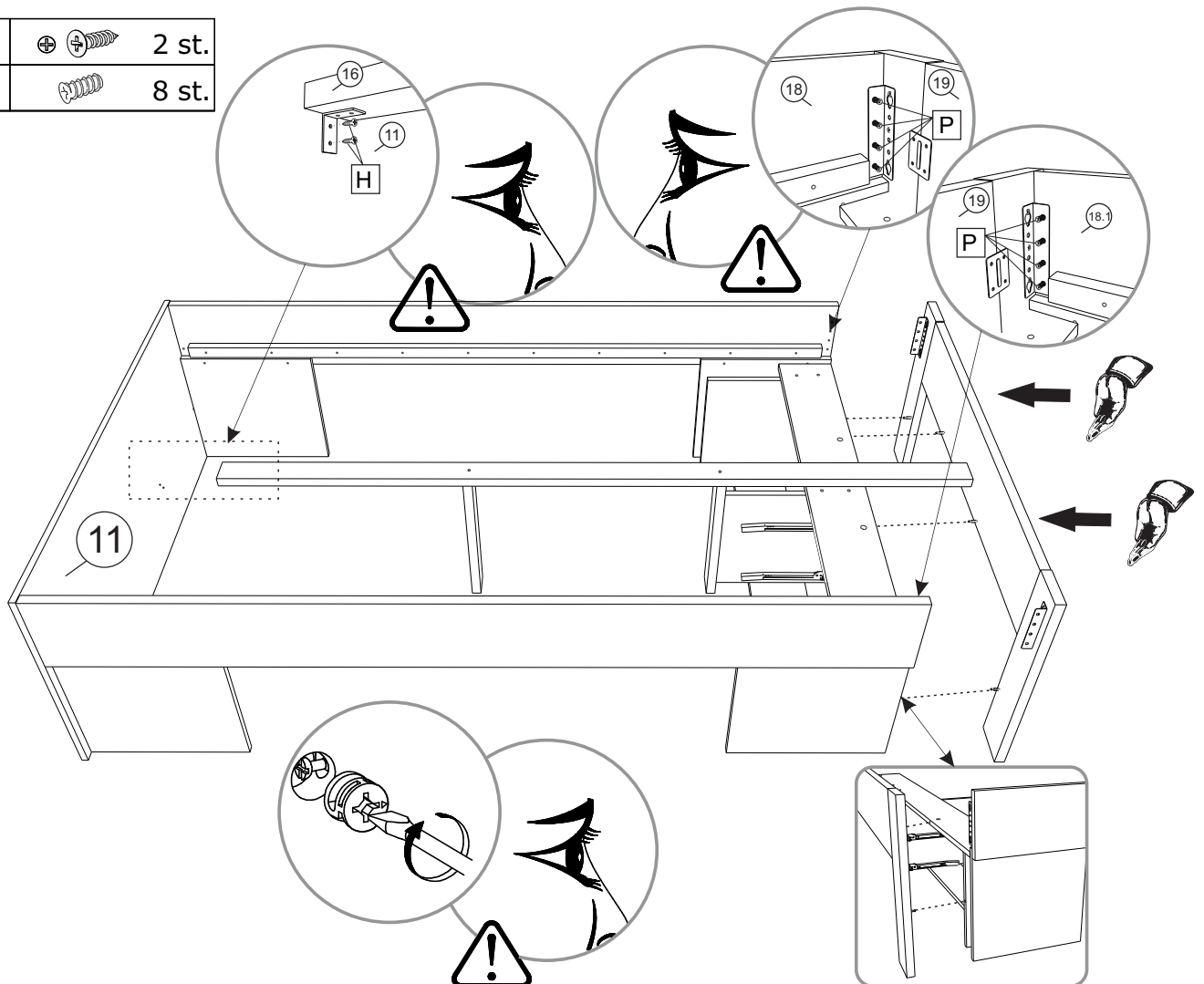

# FUTONBETT NOAH 140

28

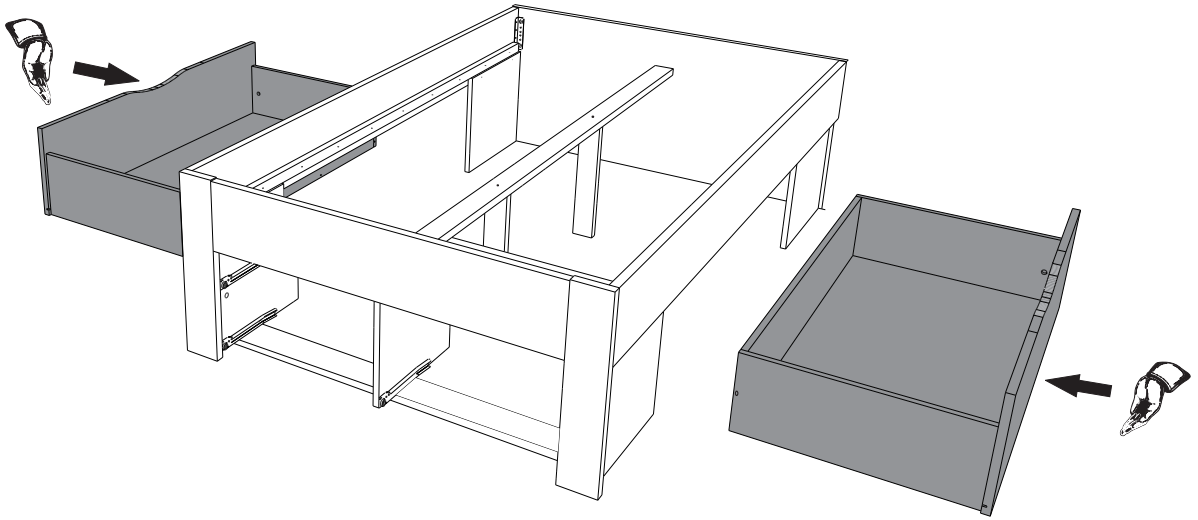

29

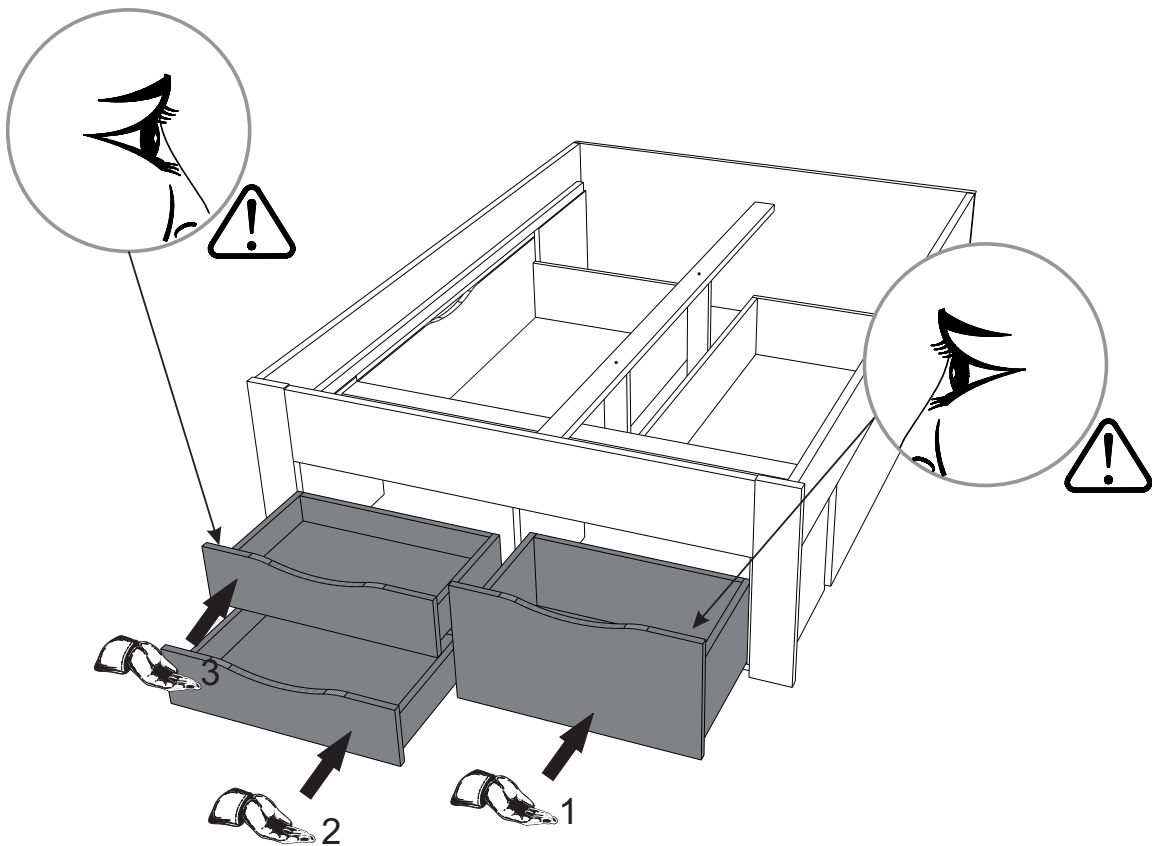

# FUTONBETT NOAH 140

30

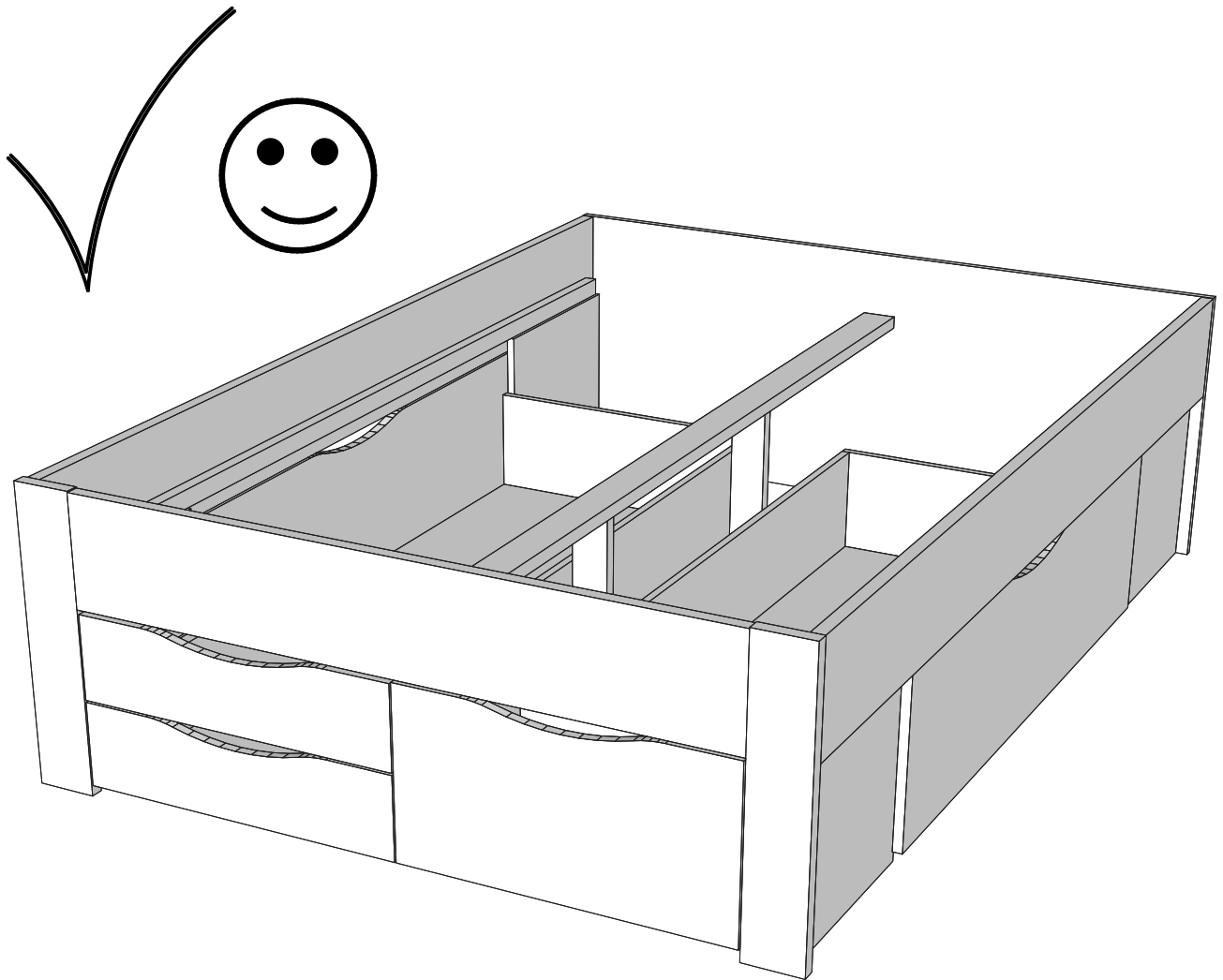

**DE** Achtung: Zu Ihrer Sicherheit ist die zulässige Höchstlast nicht zu überschreiten

**EN** Caution! For your safety, do not exceed the maximum load

**NL** Opgelet, voor uw veiligheid het maximum gewicht niet overschrijden

**FR** Attention pour votre sécurité ne pas dépasser les charges maxi

**SK** Upozornenie: Z bezpečnostných dôvodov neprekračujte maximálne záťaž

**CZ** Pozor, z bezpečnostních důvodů nepřekračujte maximální zátěž

**HU** Az Ön biztonsága érdekében ne haladja meg a maximális terhelést

**HR** Oprez! Radi vaše sigurnosti ne prelazite maksimalno opterećenje

