

## Leinenbett mit Schubladen und Lichtleiste Lit tiroir en lin avec bande lumineuse

ADC031-140x200  
ADC031-160x200  
ADC031-180x200  
ADC032-140x200  
ADC032-160x200  
ADC032-180x200

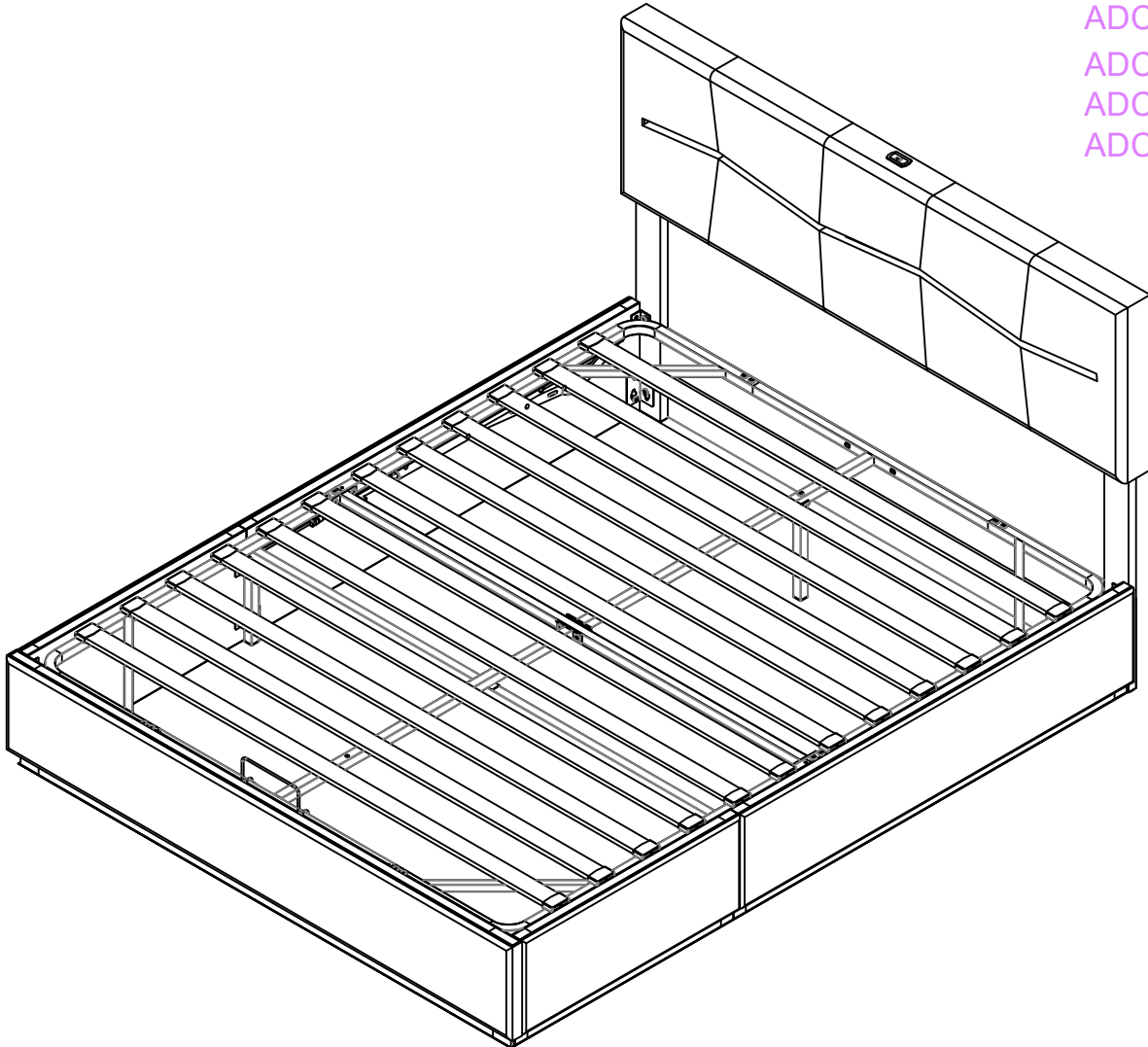

### Freundlicher Kundenservice

Zufriedenheitsgarantien: Bei Problemen mit der Montage, der Qualität oder der Rückgabe können Sie sich gerne direkt an uns wenden.

### Service client amical

Garanties de satisfaction : si vous rencontrez des problèmes d'assemblage, de qualité ou de retour, n'hésitez pas à nous contacter directement.

# IMPORTANT/WICHTIG/ATENCIÓN

## IMPORTANT/IMPORTANTE



EN-We recommend 2 or more people to install.  
DE-Wir empfehlen, dass die Montage von 2 oder mehreren Personen durchgeführt werden sollte.  
ES-Recomendamos realizar el ensamble con 2 o más personas.  
FR -Il est recommandé d'effectuer le montage à 2 personne(s) ou plus.  
IT -È necessaria la presenza di 2 o più persone per il montaggio di questo prodotto.



EN-The expected assembly time is 1 h.  
DE-Die Montagezeit beträgt durchschnittlich 1 h.  
ES-El tiempo aproximado de ensamble es de 1 h.  
FR-Le temps nécessaire est estimé à 1 h.  
IT-Il tempo previsto per il corretto assemblaggio è di 1 h.



EN-Not intended for use by children.  
DE-Nicht geeignet für Kinder.  
ES-Producto no apto para niños.  
FR -Produit non destiné à être utilisé par des enfants.  
IT - Questo prodotto non è destinato all'uso da parte dei bambini.

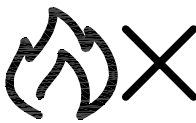

EN-Keep away from fire or other heat sources.  
DE-Bitte von Feuer und Hitzequellen fernhalten.  
ES -Manténgase alejado de las llamas y otras fuentes de calor.  
FR -Tenir à distance des flammes et autres sources de chaleur.  
IT -Tenere lontano dal fuoco o da altre fonti di calore.

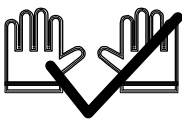

EN-We recommend wearing protective gloves.  
DE-Wir empfehlen das Tragen von Schutzhandschuhen.  
ES-Recomendamos el uso de guantes de seguridad.  
FR -Il est recommandé de porter des gants de protection.  
IT -Per il processo di assemblaggio, consigliamo fortemente l'utilizzo di guanti protettivi.

EN - Please follow the instruction manuals and use a pad to avoid damage during assembly.  
DE - Bitte folgen Sie der Anleitung und verwenden Sie eine Unterlage, um Beschädigungen bei der Montage zu vermeiden.  
ES - Por favor, siga las instrucciones del manual y utilice una cubierta o lona para proteger el producto y el suelo durante la instalación.  
FR - Suivez les instructions de la notice et utilisez une couverture ou une bache pour protéger le produit et les sols pendant le montage.  
IT - Si prega di consultare il manuale illustrativo durante il montaggio e di utilizzare un cuscinetto per evitare possibili danni.

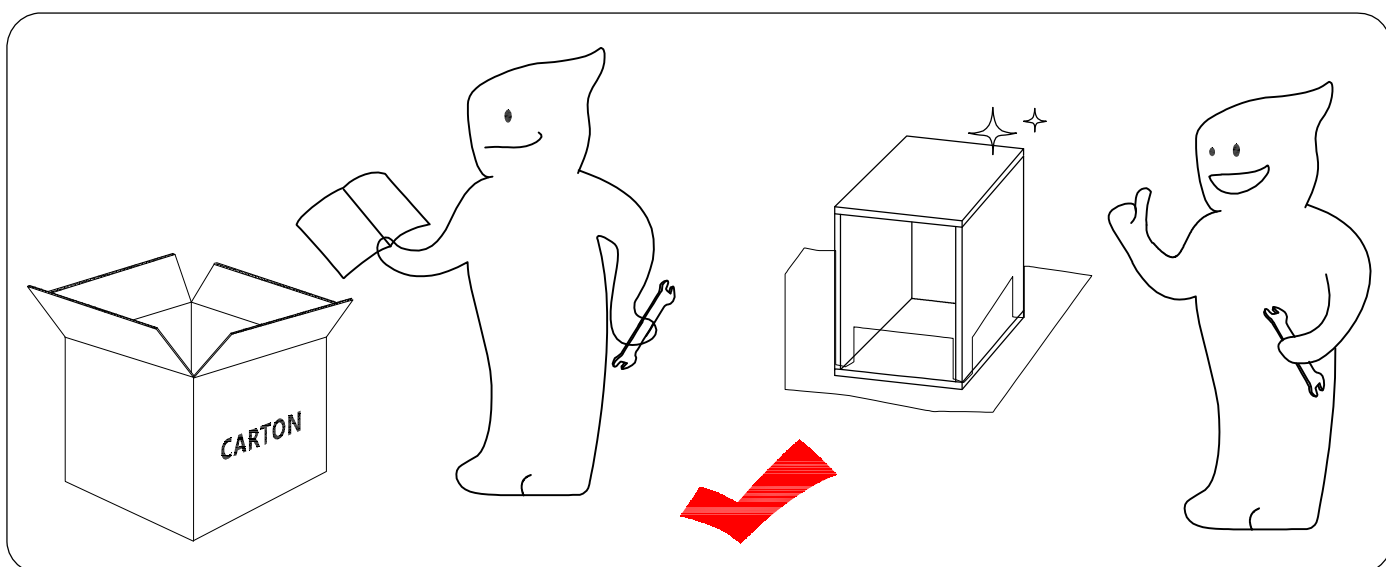
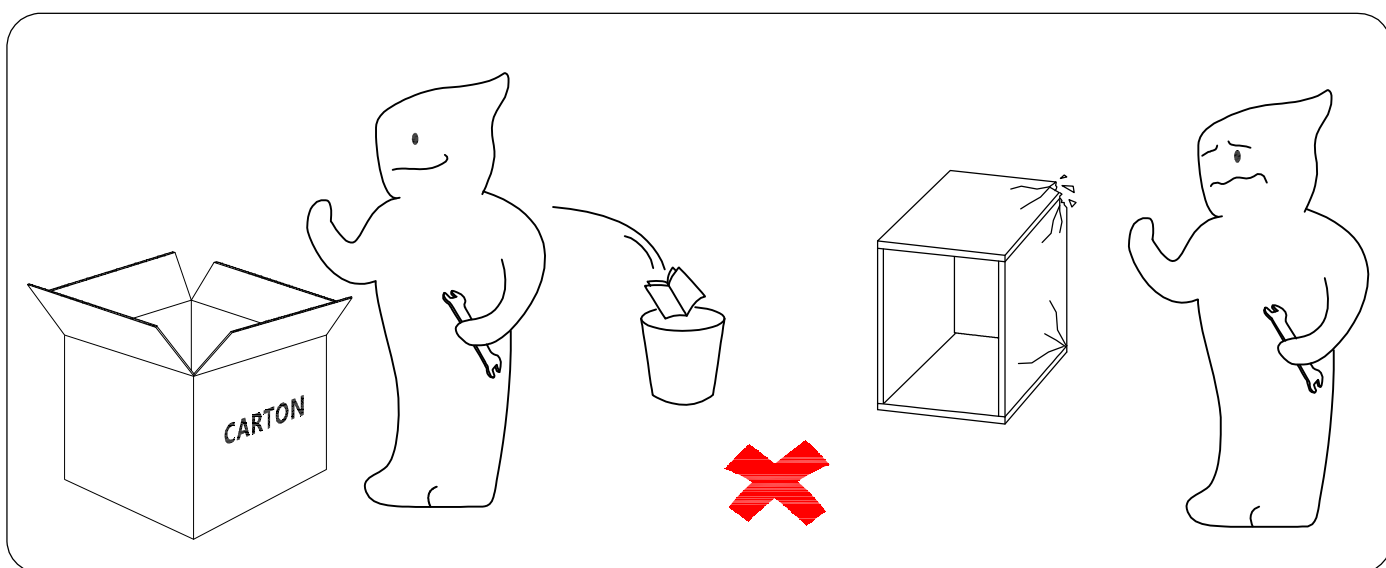

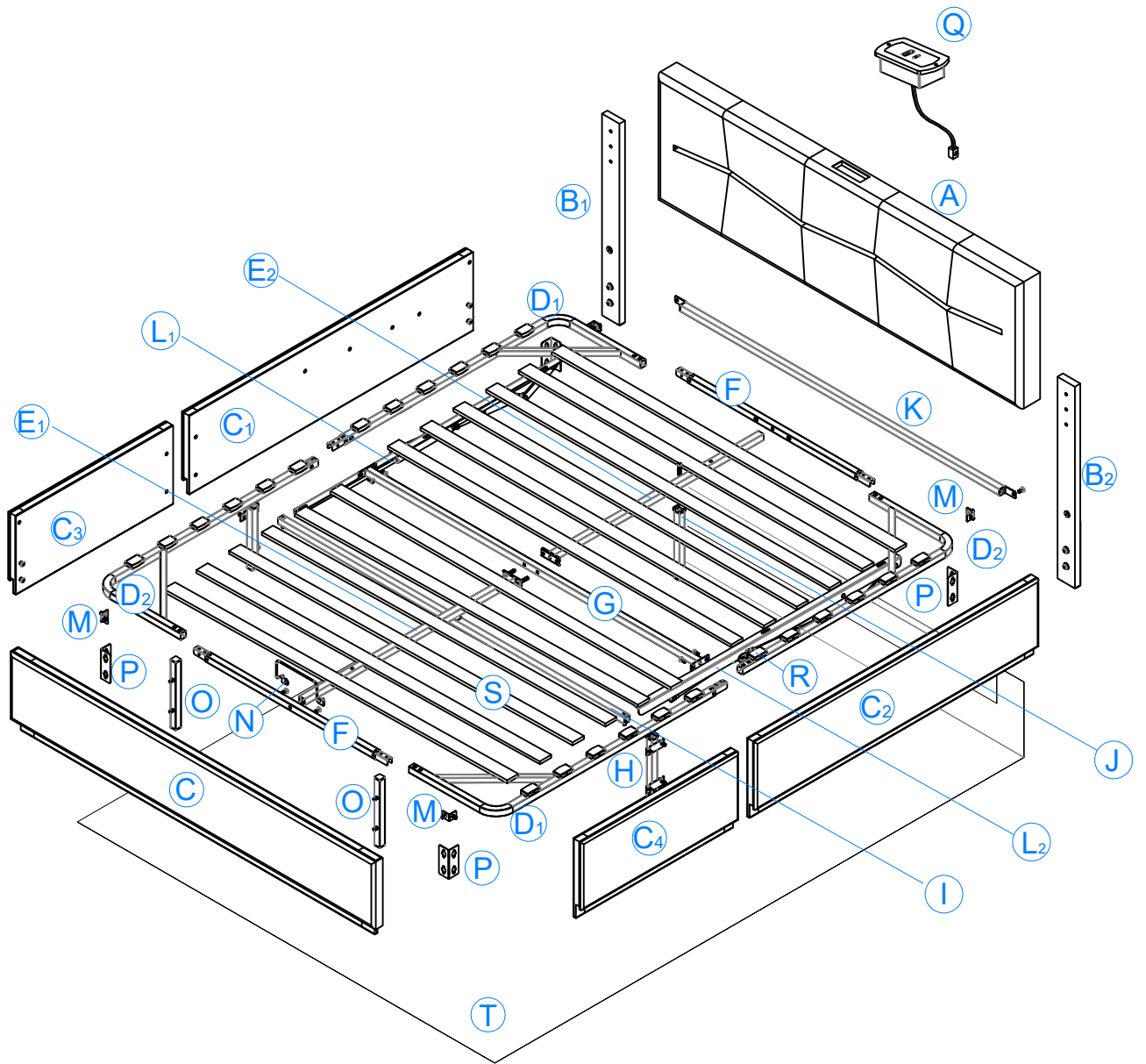

LISTE DER EINZELTEILE  
LISTE D'OBJETS

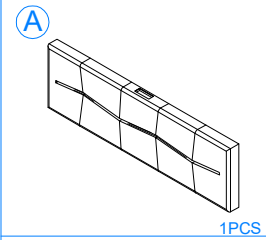
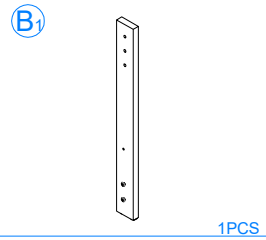
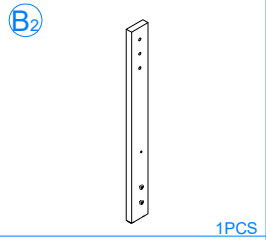
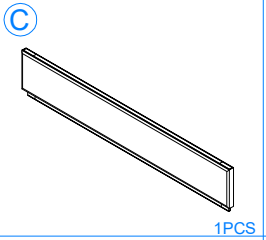
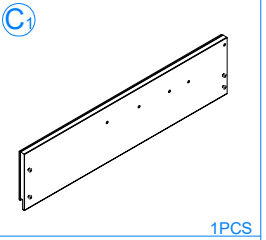
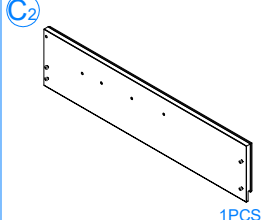
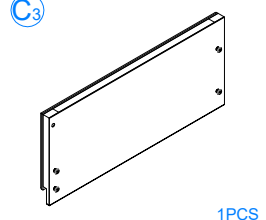
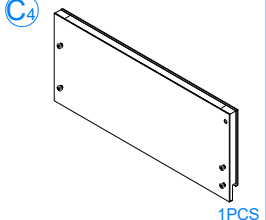
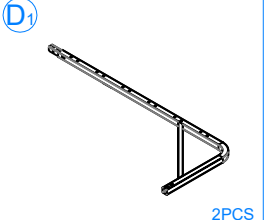
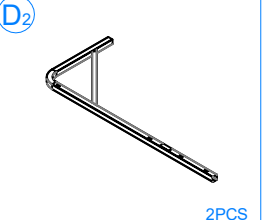
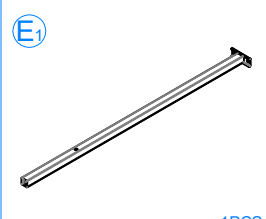
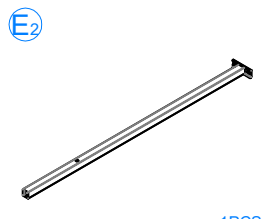
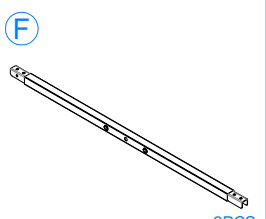
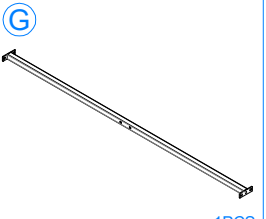
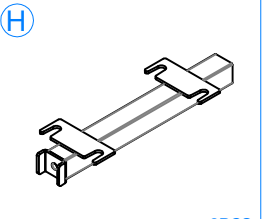
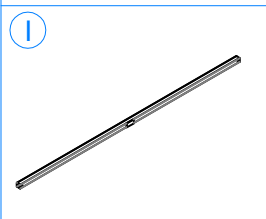
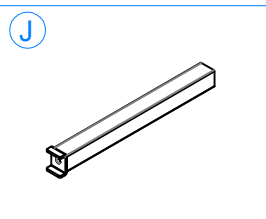
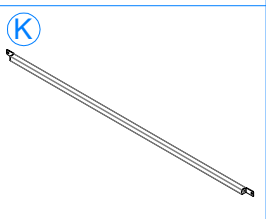
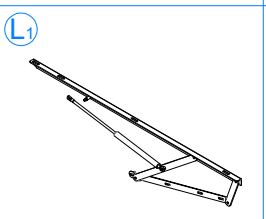
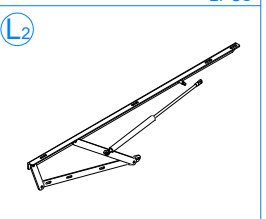
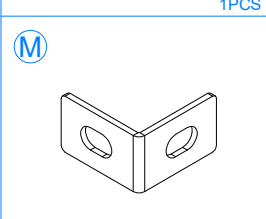
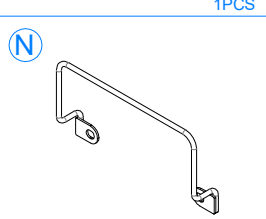
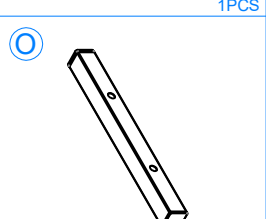
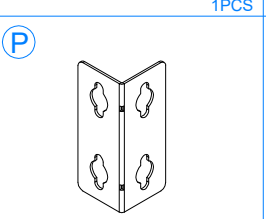
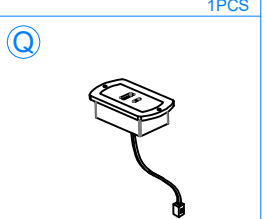
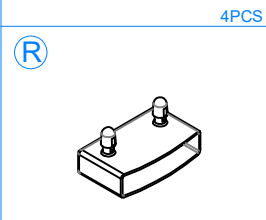
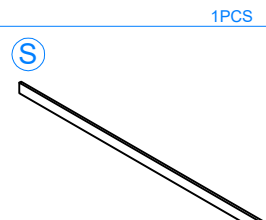
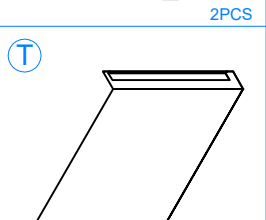
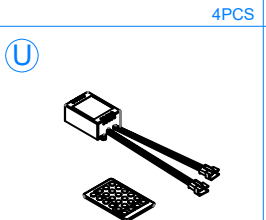
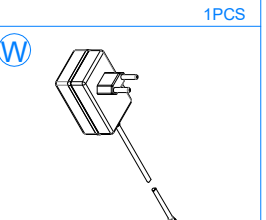
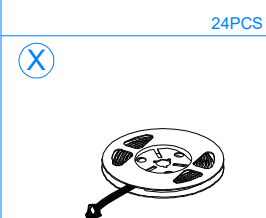
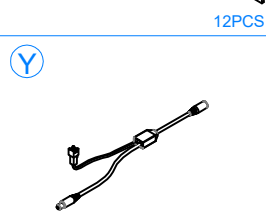
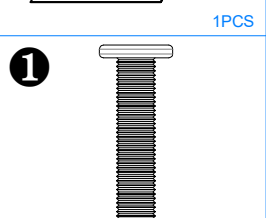
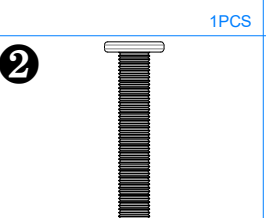
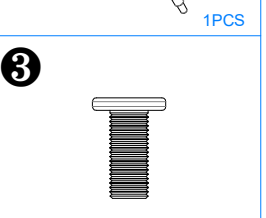
<b>A</b>  1PCS	<b>B<sub>1</sub></b>  1PCS	<b>B<sub>2</sub></b>  1PCS	<b>C</b>  1PCS	<b>C<sub>1</sub></b>  1PCS
<b>C<sub>2</sub></b>  1PCS	<b>C<sub>3</sub></b>  1PCS	<b>C<sub>4</sub></b>  1PCS	<b>D<sub>1</sub></b>  2PCS	<b>D<sub>2</sub></b>  2PCS
<b>E<sub>1</sub></b>  1PCS	<b>E<sub>2</sub></b>  1PCS	<b>F</b>  2PCS	<b>G</b>  1PCS	<b>H</b>  2PCS
<b>I</b>  1PCS	<b>J</b>  1PCS	<b>K</b>  1PCS	<b>L<sub>1</sub></b>  1PCS	<b>L<sub>2</sub></b>  1PCS
<b>M</b>  4PCS	<b>N</b>  1PCS	<b>O</b>  2PCS	<b>P</b>  4PCS	<b>Q</b>  1PCS
<b>R</b>  24PCS	<b>S</b>  12PCS	<b>T</b>  1PCS	<b>U</b>  1PCS	<b>W</b>  1PCS
<b>X</b>  2PCS	<b>Y</b>  1PCS	<b>1</b>  M8*40 13PCS	<b>2</b>  M8*50 2PCS	<b>3</b>  M8*18 44PCS

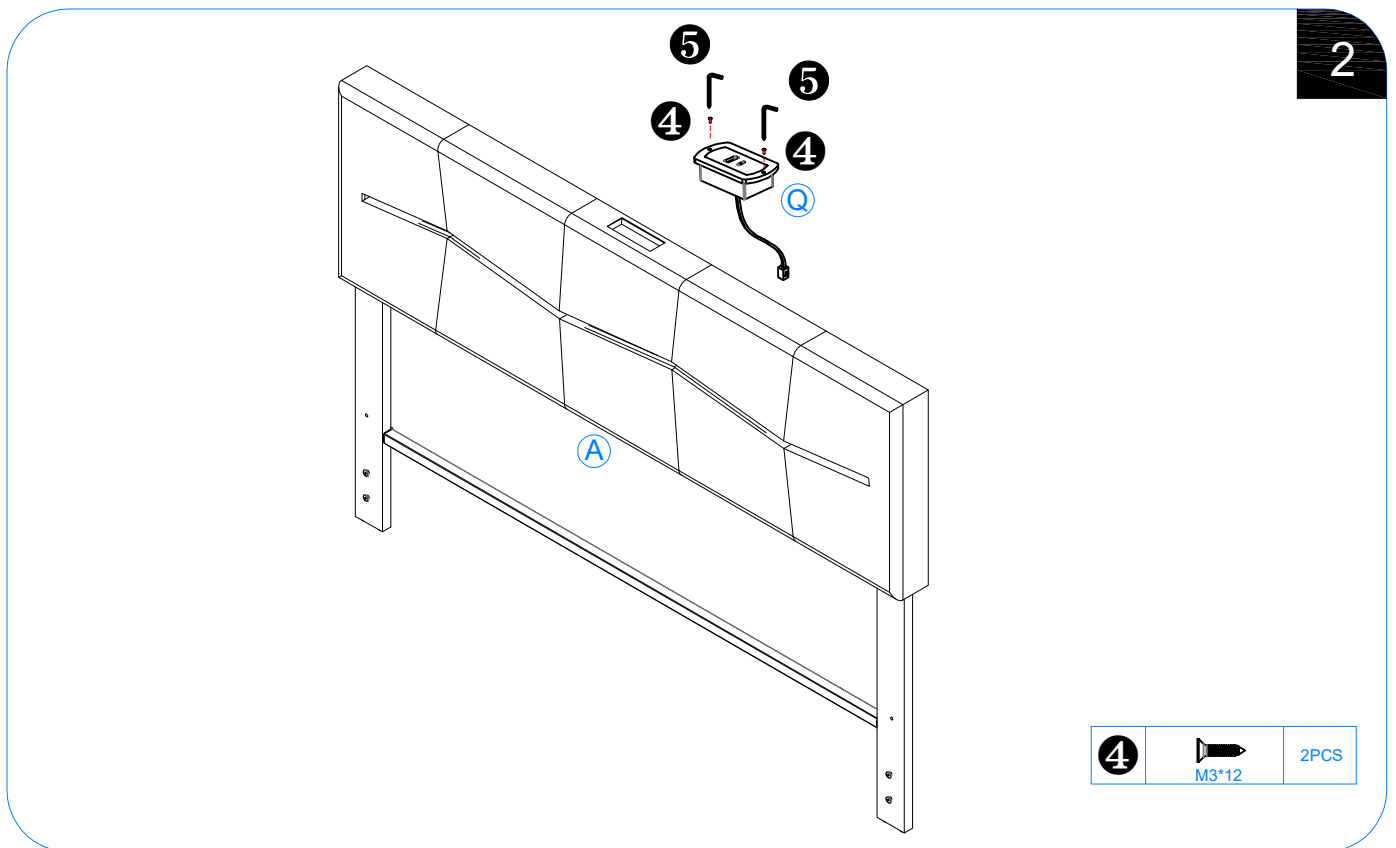
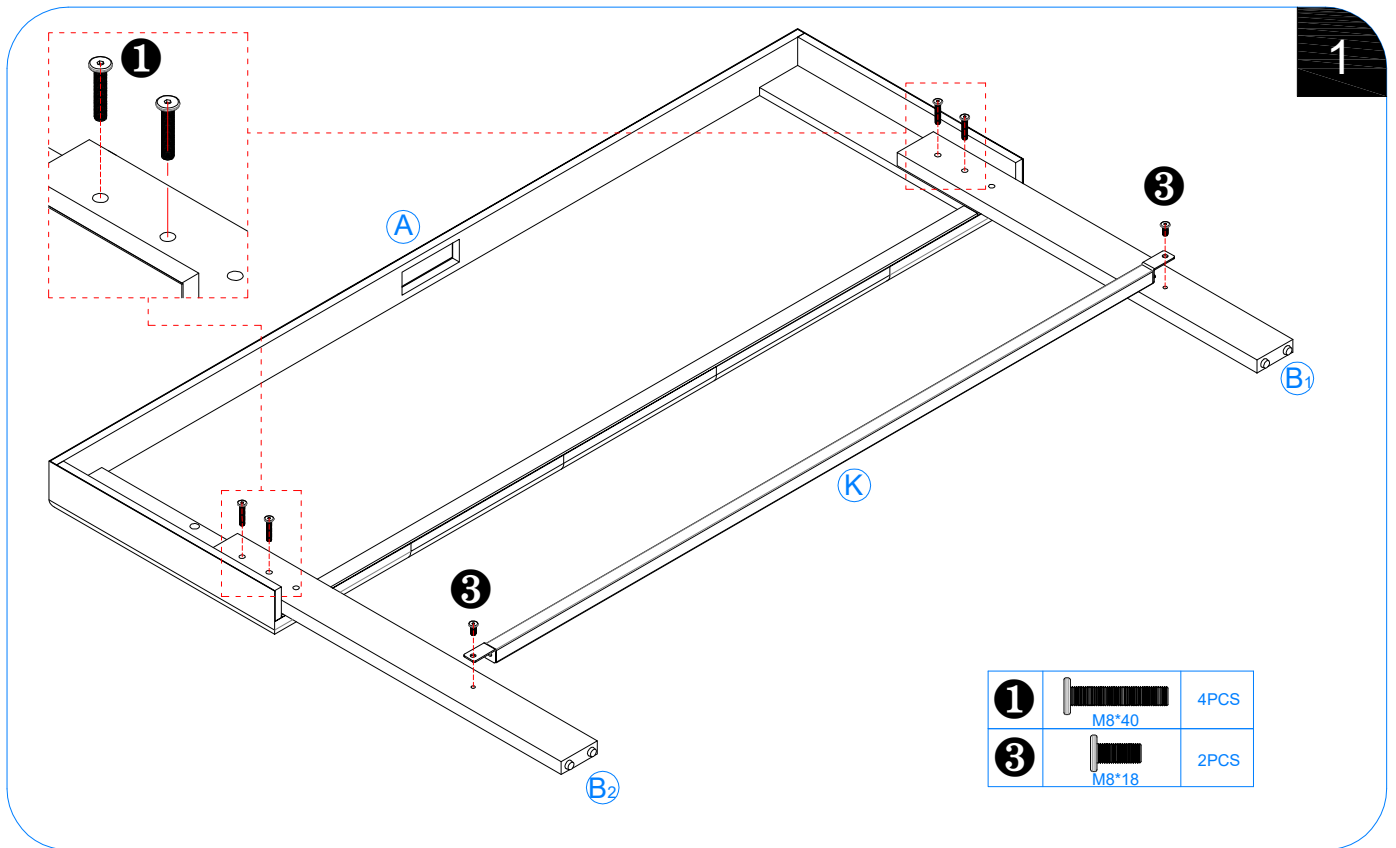

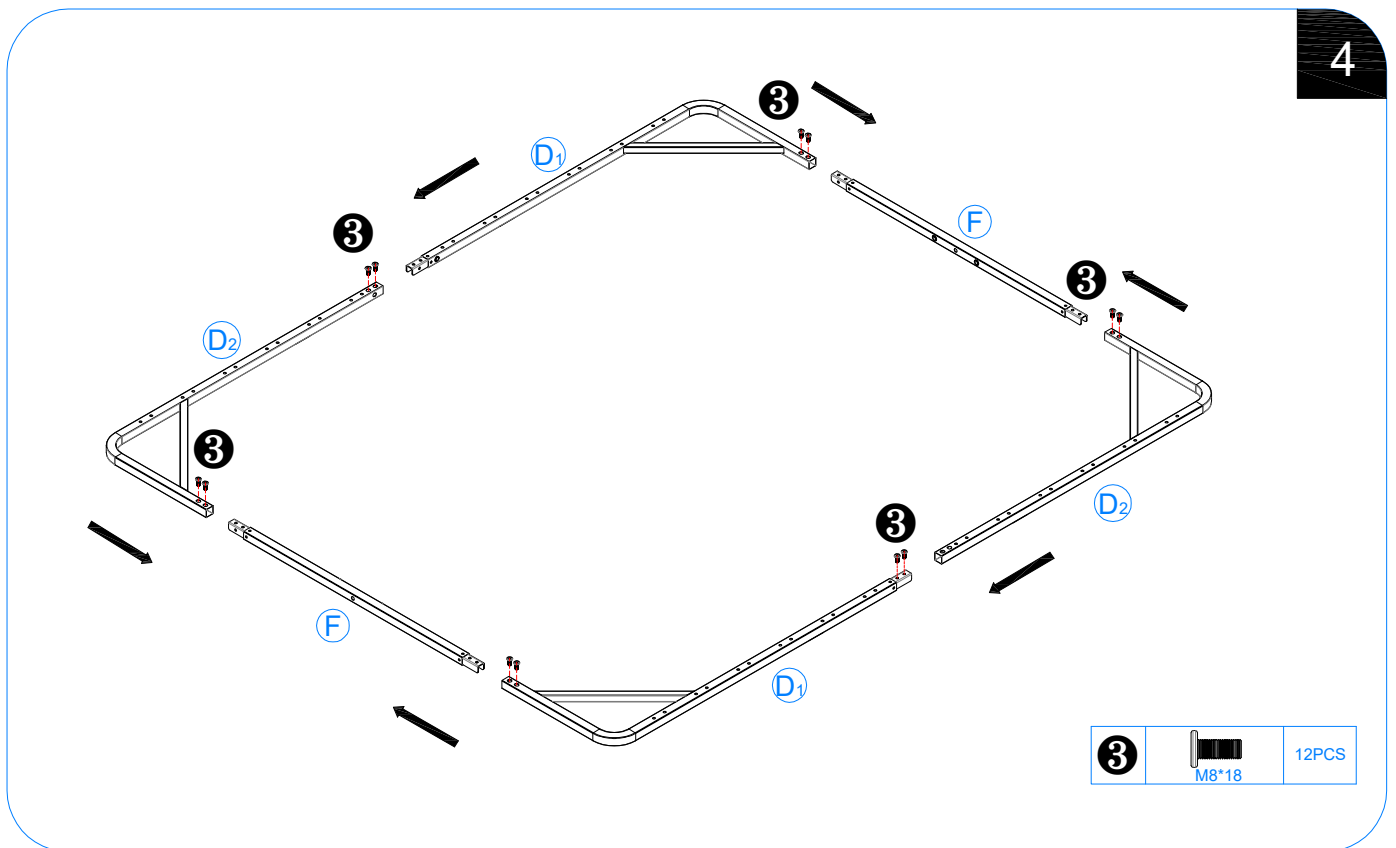
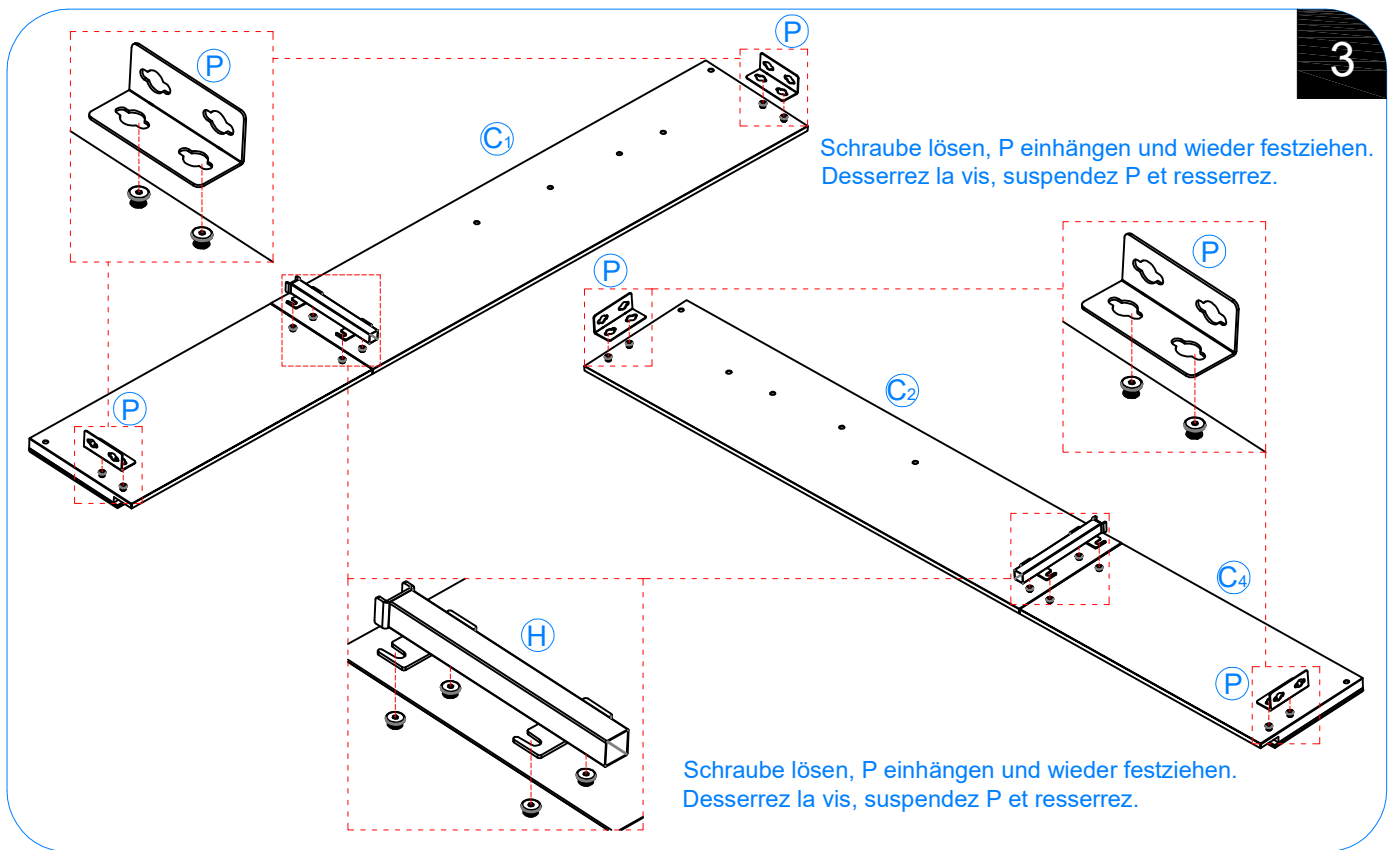

5

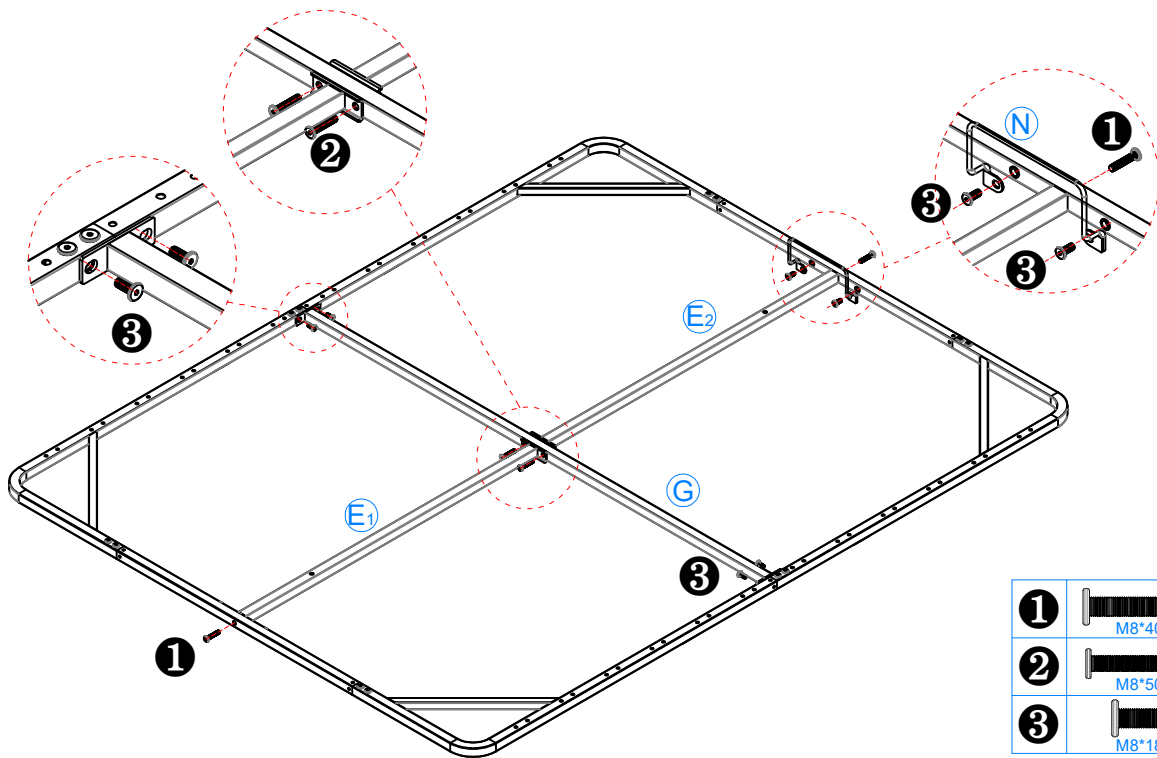

6

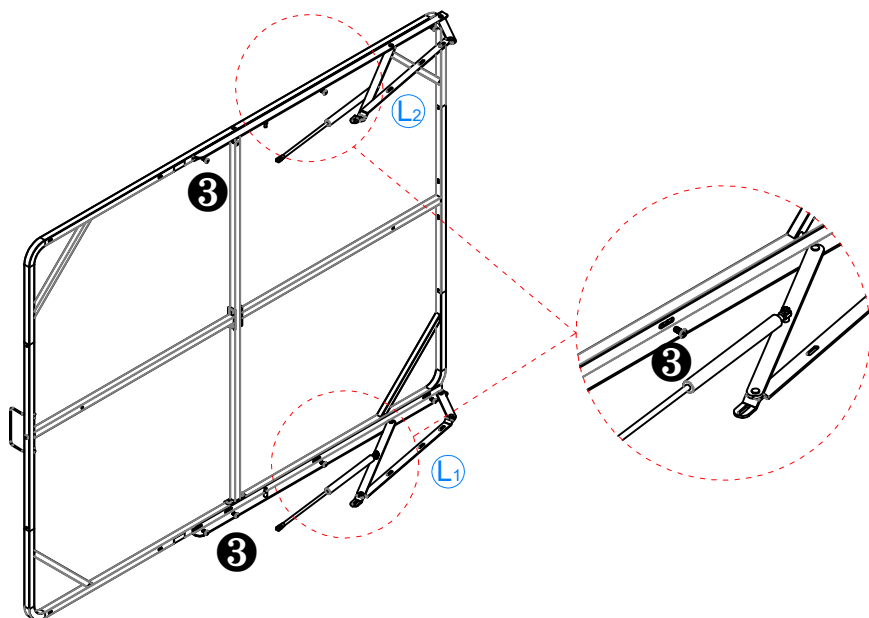

<b>3</b>		M8*18	8PCS
----------	---	-------	------



7

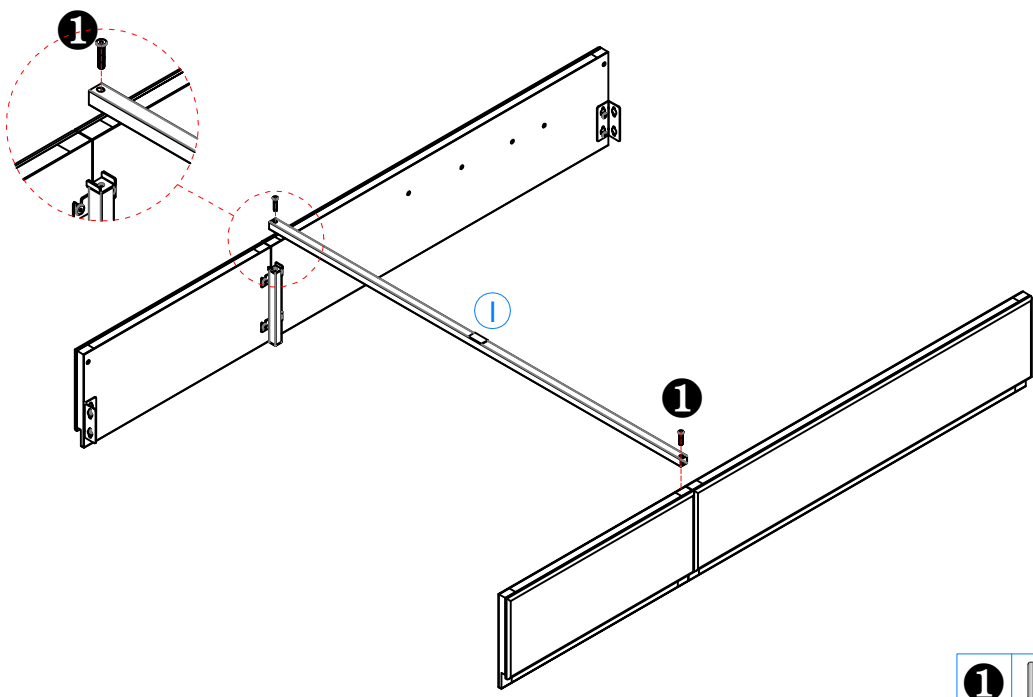

<b>1</b>		2PCS
	M8*40	

8

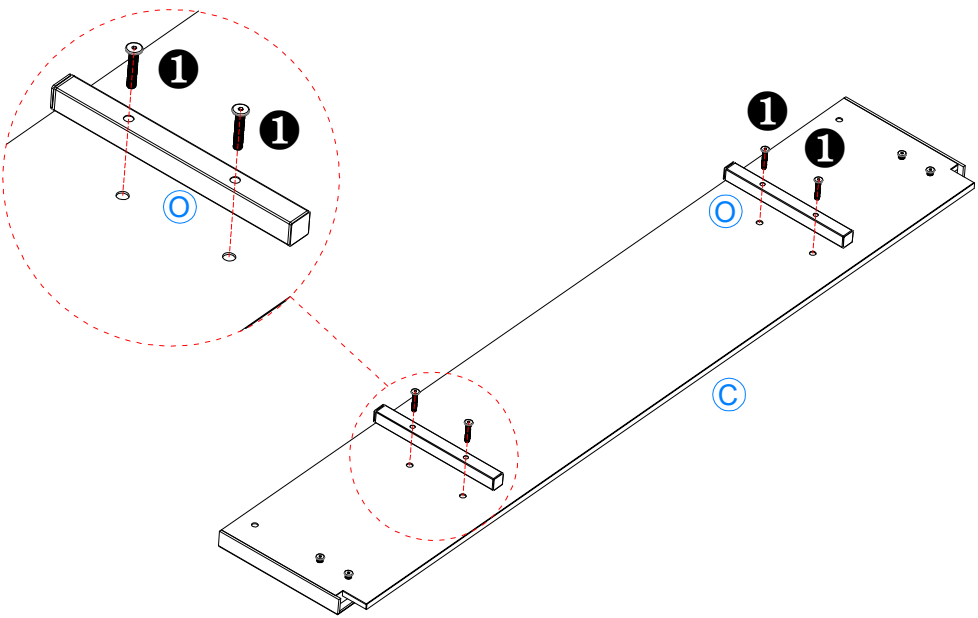

<b>1</b>		4PCS
	M8*40	

9

Schraube lösen, P einhängen und wieder festziehen.  
Desserrez la vis, suspendez P et resserrez.

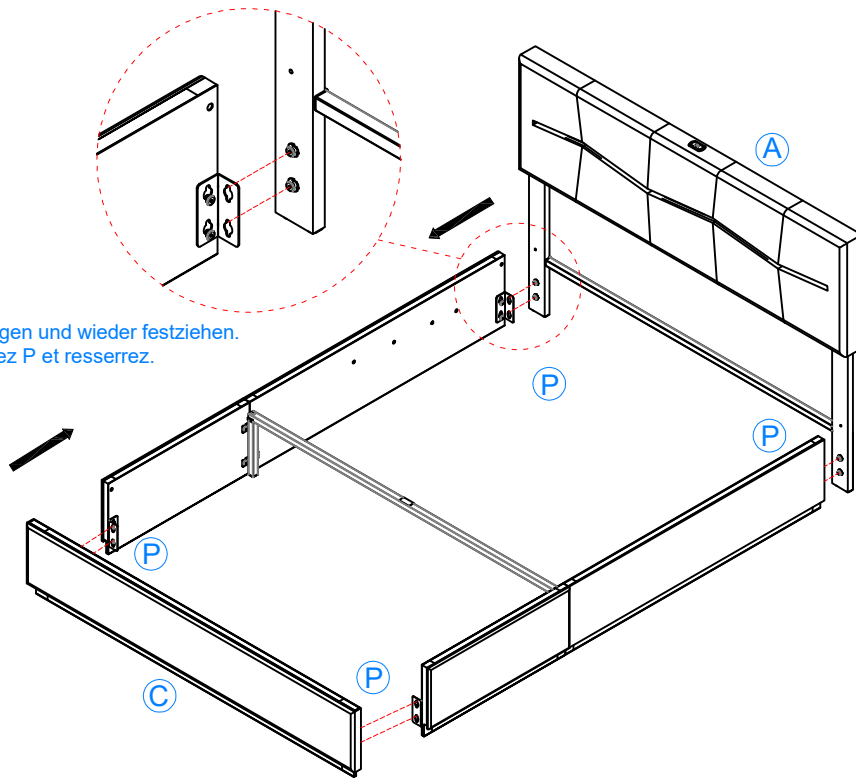

10

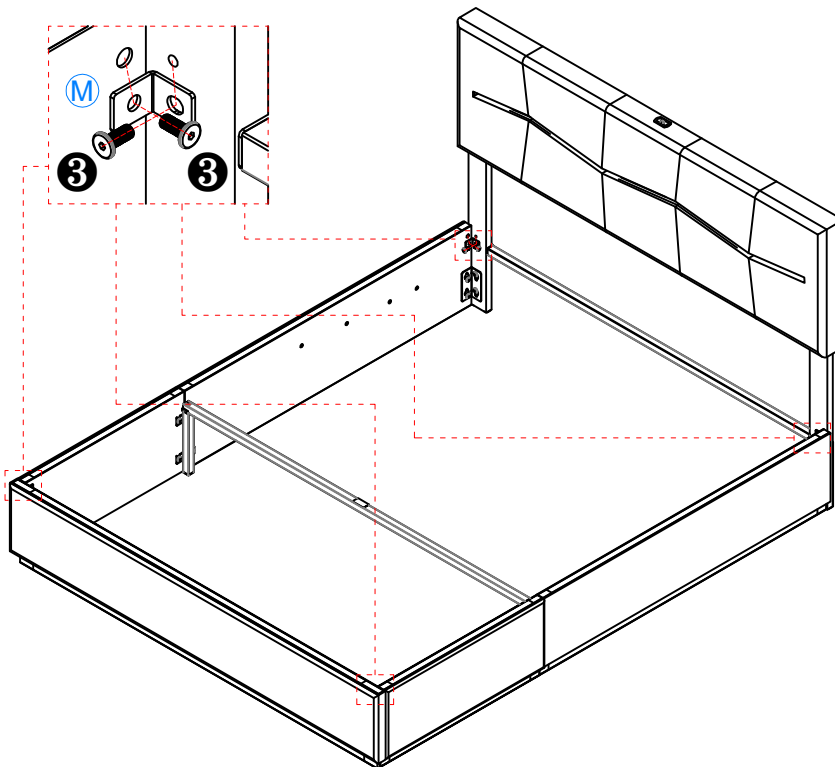

**3**  8PCS  
M8\*18

11

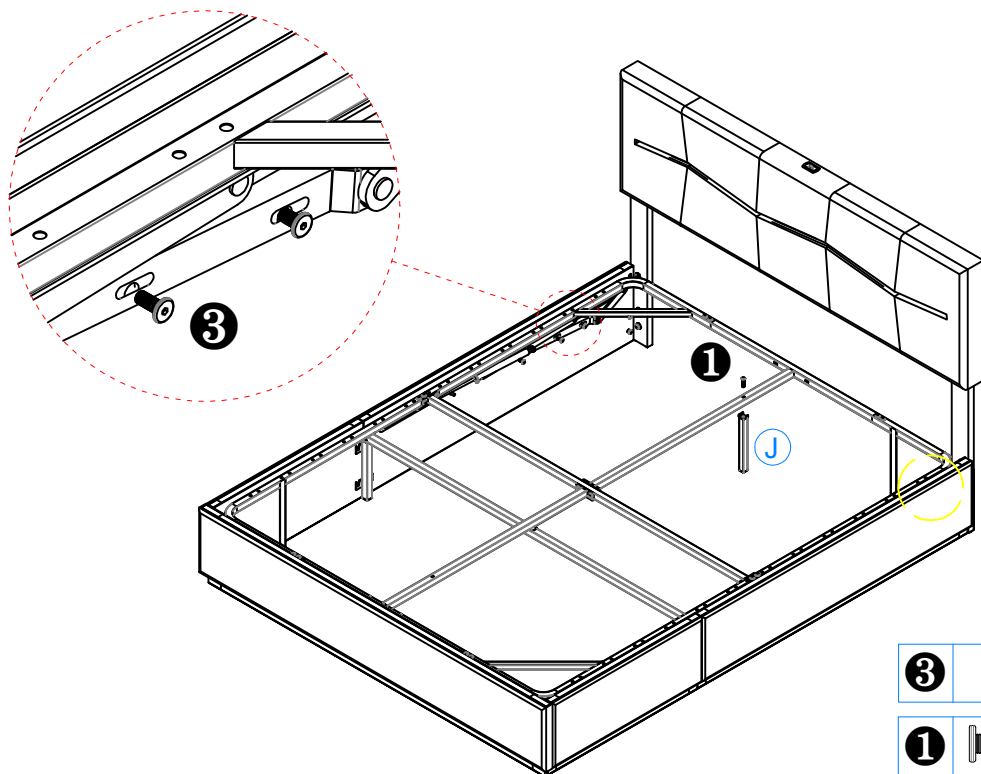

12

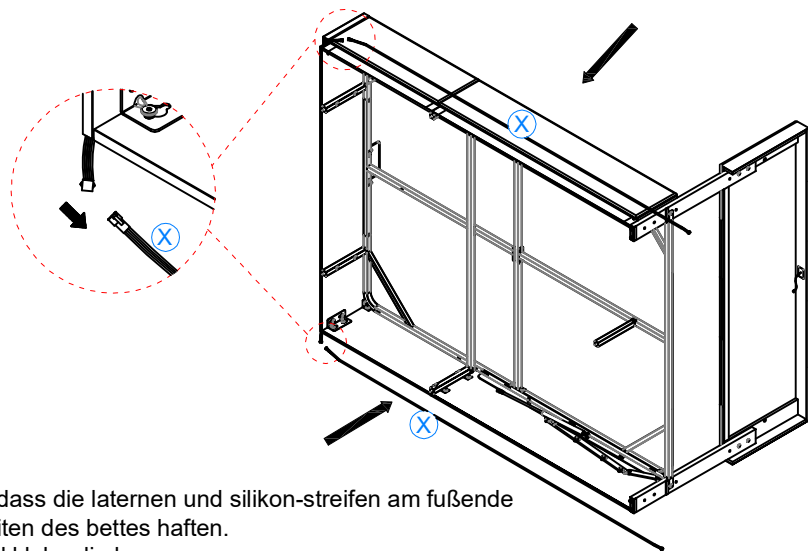

1. Der erste schritt ist sicherzustellen, dass die laterne und silikon-streifen am fußende und die silikon-streifen an beiden seiten des bettes haften.
2. Nimm die seitenseite des bettes und klebe die lampe an.
3. Die laterne am bett mit dem fußende verbinden.
1. La première étape consiste à s'assurer que la lampe et la bande de silicone sont collées à l'extrémité du lit, et la bande de silicone est collée des deux côtés du lit.
2. Enlevez la bande de silicone sur le côté du lit, collez la lampe et réinitialisez la bande de silicone.
3. Connectez la tête de la lampe sur le côté du lit et l'extrémité du lit.

13

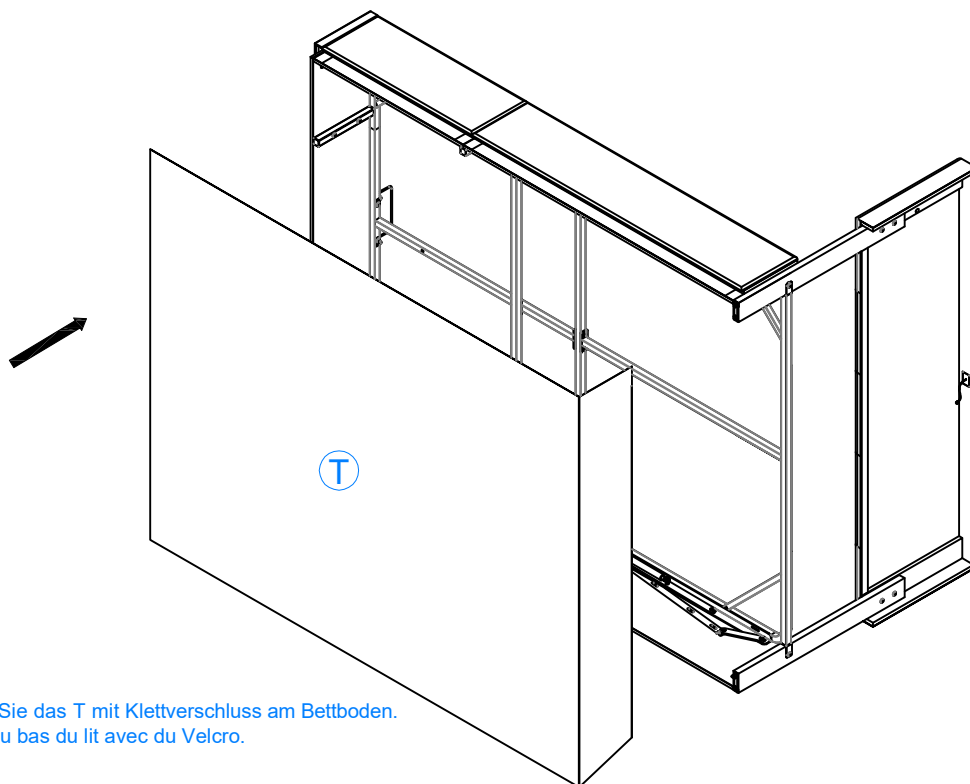

Befestigen Sie das T mit Klettverschluss am Bettboden.  
Fixez le T au bas du lit avec du Velcro.

14

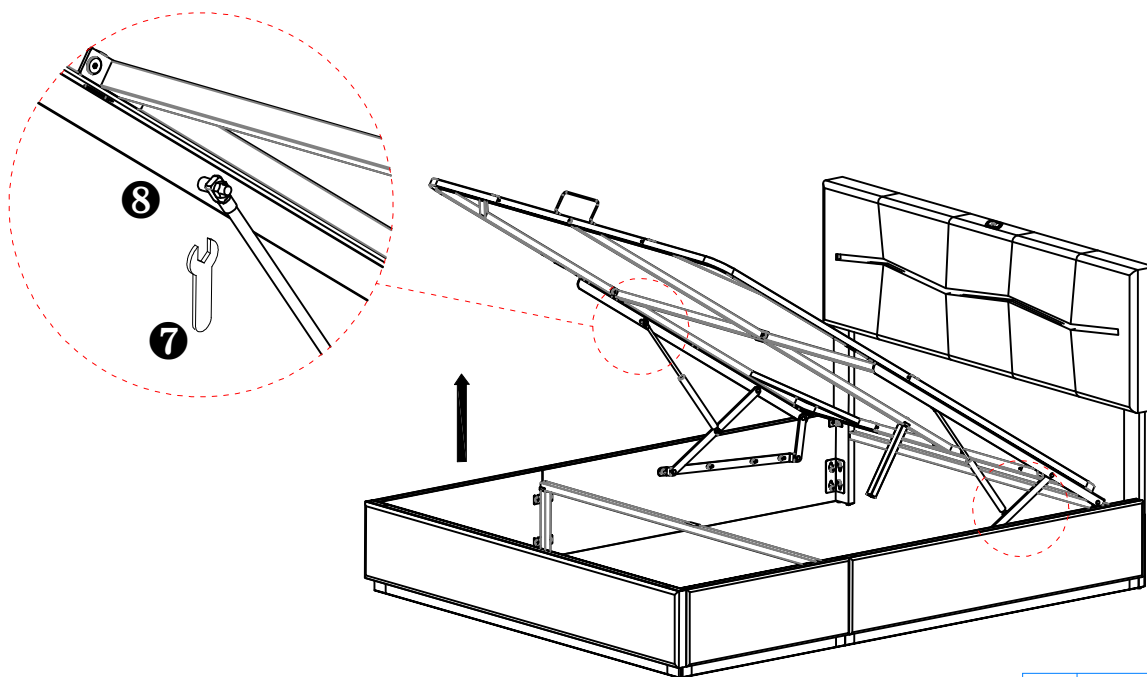

8	 M8	2PCS
---	---	------

15

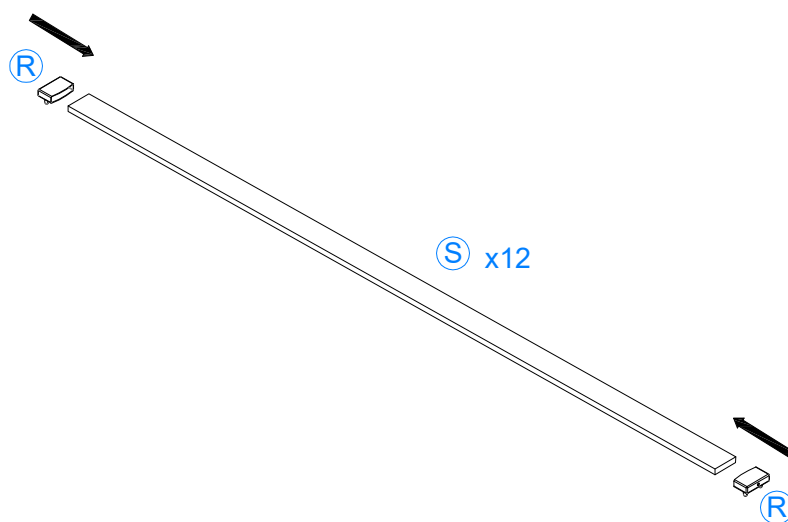

16

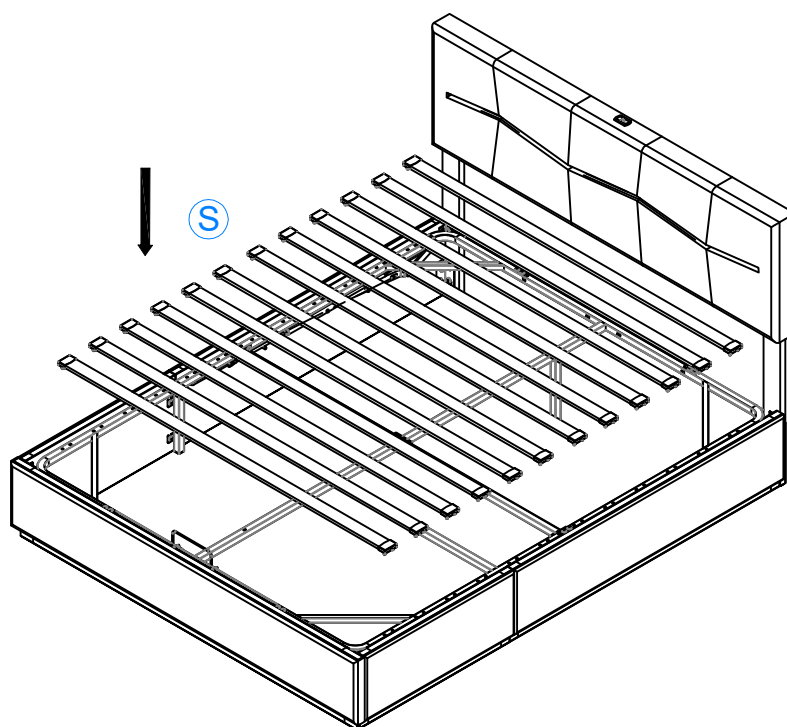

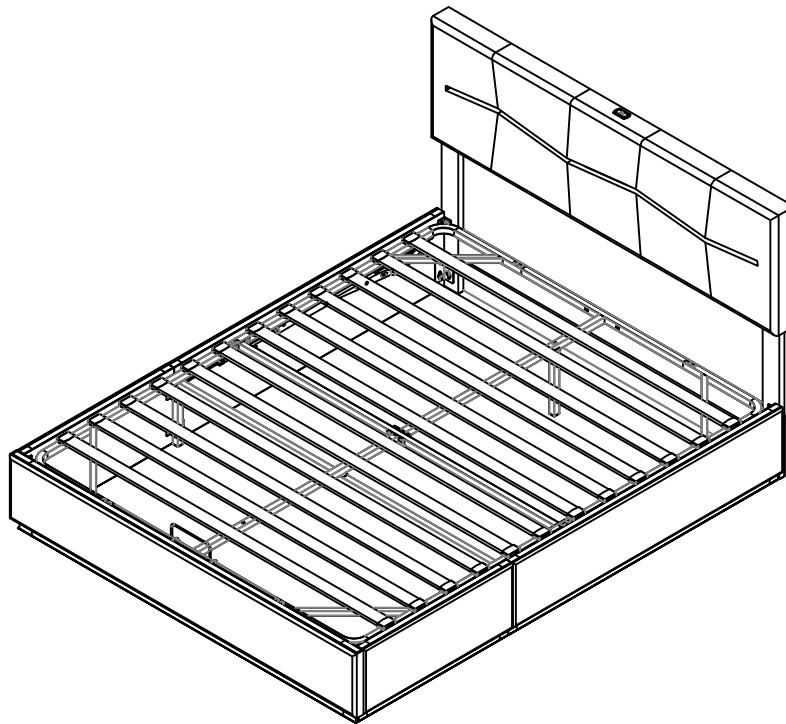
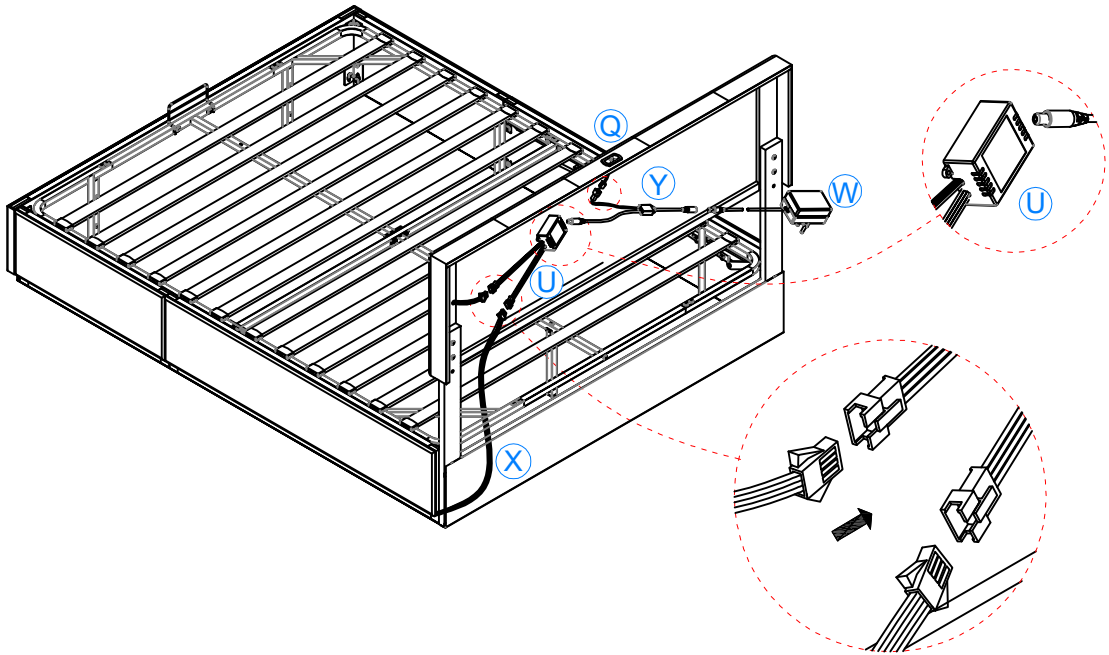

Fertiges Produkt  
Produit fini