



**D**

### Wichtige Sicherheitshinweise

Die Installation Ihrer neuen Leuchte darf ausschließlich von autorisierten Fachpersonen durchgeführt werden.



[www.till-hilft.de](http://www.till-hilft.de)

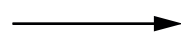

Montagehilfen



**PL**

### Ważne wskazówki dotyczące bezpieczeństwa

Ta instalację nowej lampy mogą przeprowadzać wyłącznie autoryzowani instalatorzy



[www.till-hilft.de](http://www.till-hilft.de)

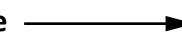

Montagehilfen



**GB**

### Important safety instructions

The installation of your new luminaire may only be carried out by authorized specialists.



[www.till-hilft.de](http://www.till-hilft.de)



Montagehilfen



**SK**

### Dôležité bezpečnostné upozornenia

Inštaláciu lampy smú vykonať výhradne autorizovaní



[www.till-hilft.de](http://www.till-hilft.de)

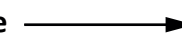

Montagehilfen



**FR**

### signes de sécurité importantes

La L'installation votre nouveau luminaire doit uniquement être réalisée par des spécialistes autorisés



[www.till-hilft.de](http://www.till-hilft.de)

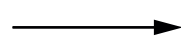

Montagehilfen



**HU**

### Fontos biztonsági utmutatások

Az On Új lámpájának beszerelését kizárólag hivatalos szakember végezheti el



[www.till-hilft.de](http://www.till-hilft.de)

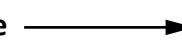

Montagehilfen



**IT**

### Important disposizioni di sicurezza

L'installazione della il loro nuovo lampada può essere eseguita solo ed esclusivamente da personale tecnico autorizzato.



[www.till-hilft.de](http://www.till-hilft.de)

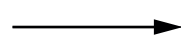

Montagehilfen



**RO**

### Instrucțiuni de siguranță importante

Instalarea noii dumneavoastră lămpi este permisă exclusiv specialișilor autorizați



[www.till-hilft.de](http://www.till-hilft.de)

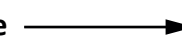

Montagehilfen



**NL**

### Belangrijke veiligheidsaanwijzingen

De installatie van de nieuwe lamp moet worden uitgevoerd door vakkbekwame personen worden uitgevoerd.



[www.till-hilft.de](http://www.till-hilft.de)

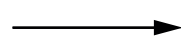

Montagehilfen



**TR**

### Önemli güvenlik uyarıları

Yeni lamba montajı yetkin kişiler tarafından yapılmalıdır



[www.till-hilft.de](http://www.till-hilft.de)

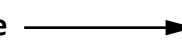

Montagehilfen



**CZ**

### Důležitá bezpečnostní pokyny

Instalaci nových svídel smí provádět pouze kvalifikovaný elektrikář



[www.till-hilft.de](http://www.till-hilft.de)



Montagehilfen



**RU**

### важная информация по технике безопасности

Установка вашей новой лампы должна выполняться квалифицированным персоналом



[www.till-hilft.de](http://www.till-hilft.de)



Montagehilfen



89904.330



88084.537

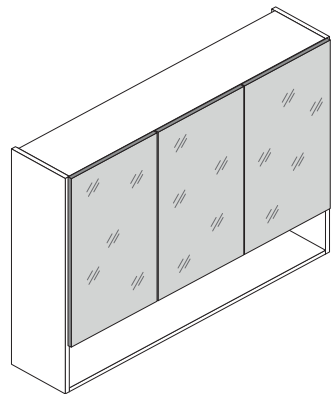

3D-Effekt

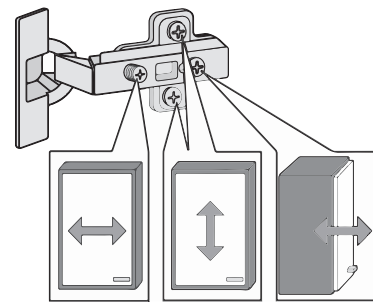
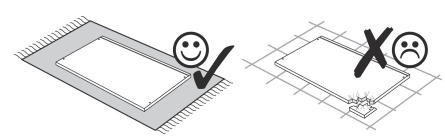
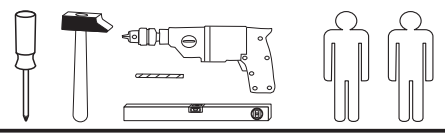
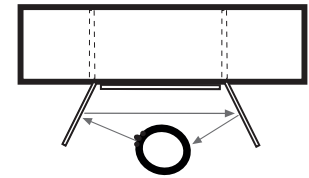

<b>1</b> 4 x 2802	<b>2</b> 4 x 2801	gedämpft <b>3</b> 3 x 1506	ungedämpft <b>4</b> 3 x 1507	<b>5</b> 6 x 1614	<b>6</b> 3,5 x 15 28 x 2804
<b>7</b> 8 x 30 16 x 2861	<b>8</b> 4 x 30 6 x 2812	<b>9</b> 5,8 x 55 3 x 2840	<b>10</b> 8 x 30 3 x 2842	<b>11</b> 3 x 2843.1	<b>12</b> 6 x 2865
<b>13</b> Leim 1 x 2863	<b>14</b> 24 x 2819	<b>15</b> 600.00.02 1 x	<b>16</b> 3,5 x 17 20 x 2832	<b>17</b> 6 x 2552	<b>18</b> 5 x 25 4 x 2860
<b>19</b> 1 x	<b>20</b> 8mm 4 x	<b>21</b> 1 x 5330			

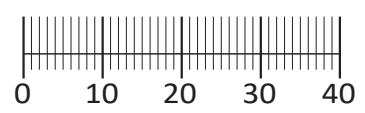
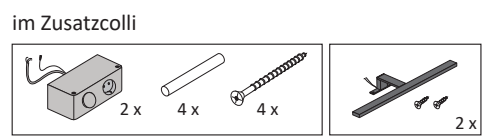

Das beigegefügte Wandbefestigungsmaterial (Dübel und Schrauben) eignet sich nur für festes Mauerwerk (z.B.: Beton- oder Ziegelwände). Für andere Wandaufbauten sind eventuell Spezialdübel und andere Schrauben notwendig. Ziehen Sie gegebenenfalls eine Fachkraft zu Rate.

Приложенный материал для крепления к стене (дюбели и винты) пригоден только для жестких кладок (например, бетонные или кирпичные стены). Для других настенных конструкций необходимы смотря по обстоятельствам специальные дюбели и другие винты. При необходимости проконсультируйтесь у специалиста.

Załączony materiał do mocowania do ściany (kolki rozprężne i wkręty) nadaje się tylko do ścian murowanych (np. z betonu lub cegieł). Do ścian wykonanych w innych technologiach konieczne być mogą specjalne kolki rozprężne i inne wkręty. W razie potrzeby skorzystaj z fachowej pomocy.

The accompanying wall mounting hardware (anchors and screws) is suitable only for solid masonry (eg concrete or brick walls). For other wall structures are possibly special anchor bolts and other necessary. Tighten if necessary, an expert.

De begeleidende wandmontage hardware (pluggen en schroeven) is alleen geschikt voor massief metselwerk (bijvoorbeeld beton of bakstenen muren). Voor andere muur structuren zijn eventueel bijzondere ankerbouten en andere noodzakelijke. Draai indien nodig, een deskundige.

Le mur d'accompagnement matériel de montage (chevilles et les vis) ne convient que pour la maçonnerie solide (par exemple en béton ou des murs de briques). Pour les structures de mur d'autres sont peut-être spéciale boulons d'ancrage et d'autres nécessaires. Serrer le cas échéant, un expert.

Il muro di accompagnamento hardware di montaggio (tasselli e viti) è'e adatto solo per muratura piena (ad esempio calcestruzzo o muratura). Per le altre strutture murarie sono forse speciali bulloni di ancoraggio e necessari di altri. Serrare se necessario, un esperto.

Ekteki duvara sabit montaj malzemeleri (dübel ve vidalar), sadece sağlam duvarlar için (örnek: beton veya tuğla) elverişlidir. Başka duvarlar için özel dübeller ve farklı vidalar gerekebilir. Gerektiğinde bir uzmana danışınız.

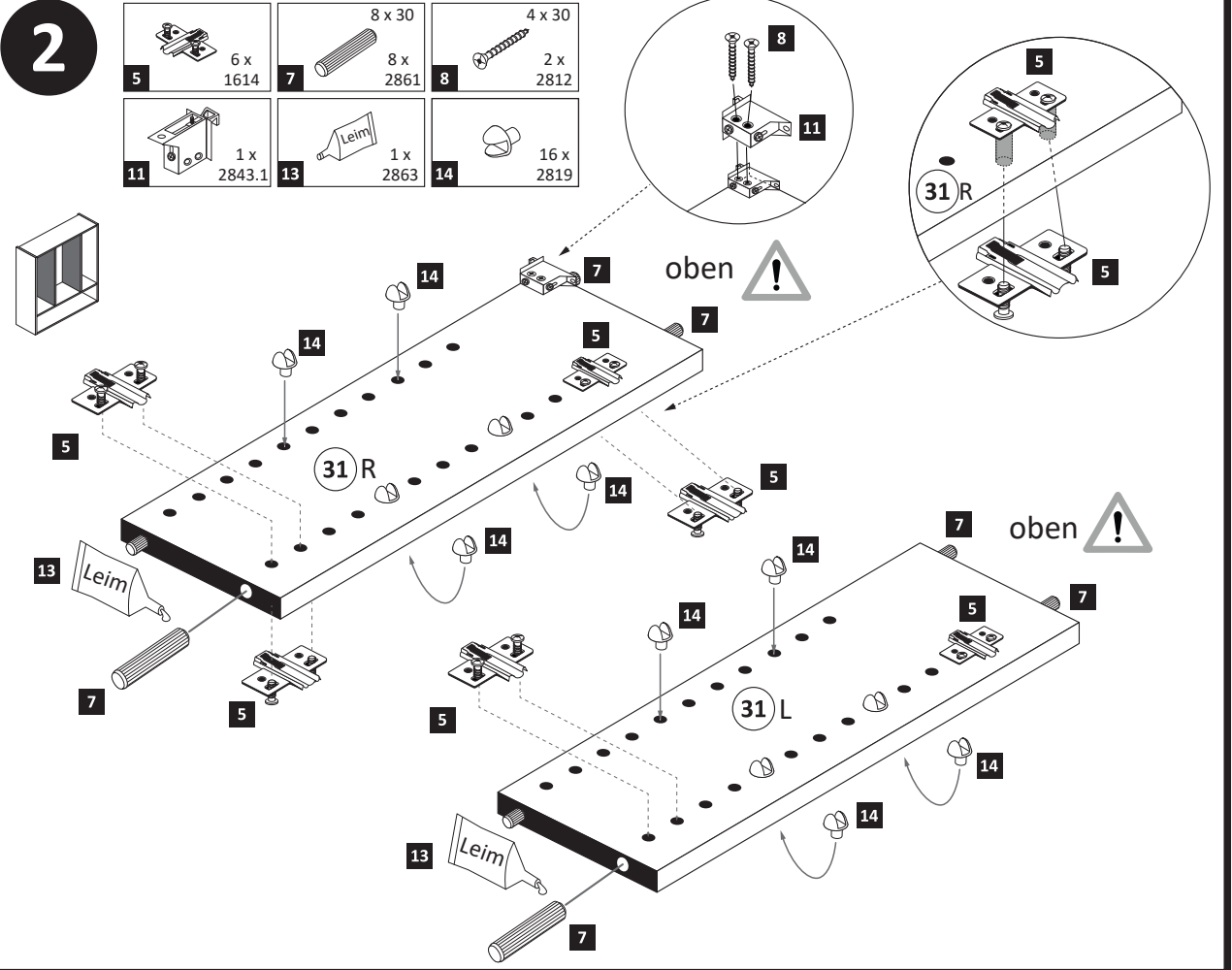
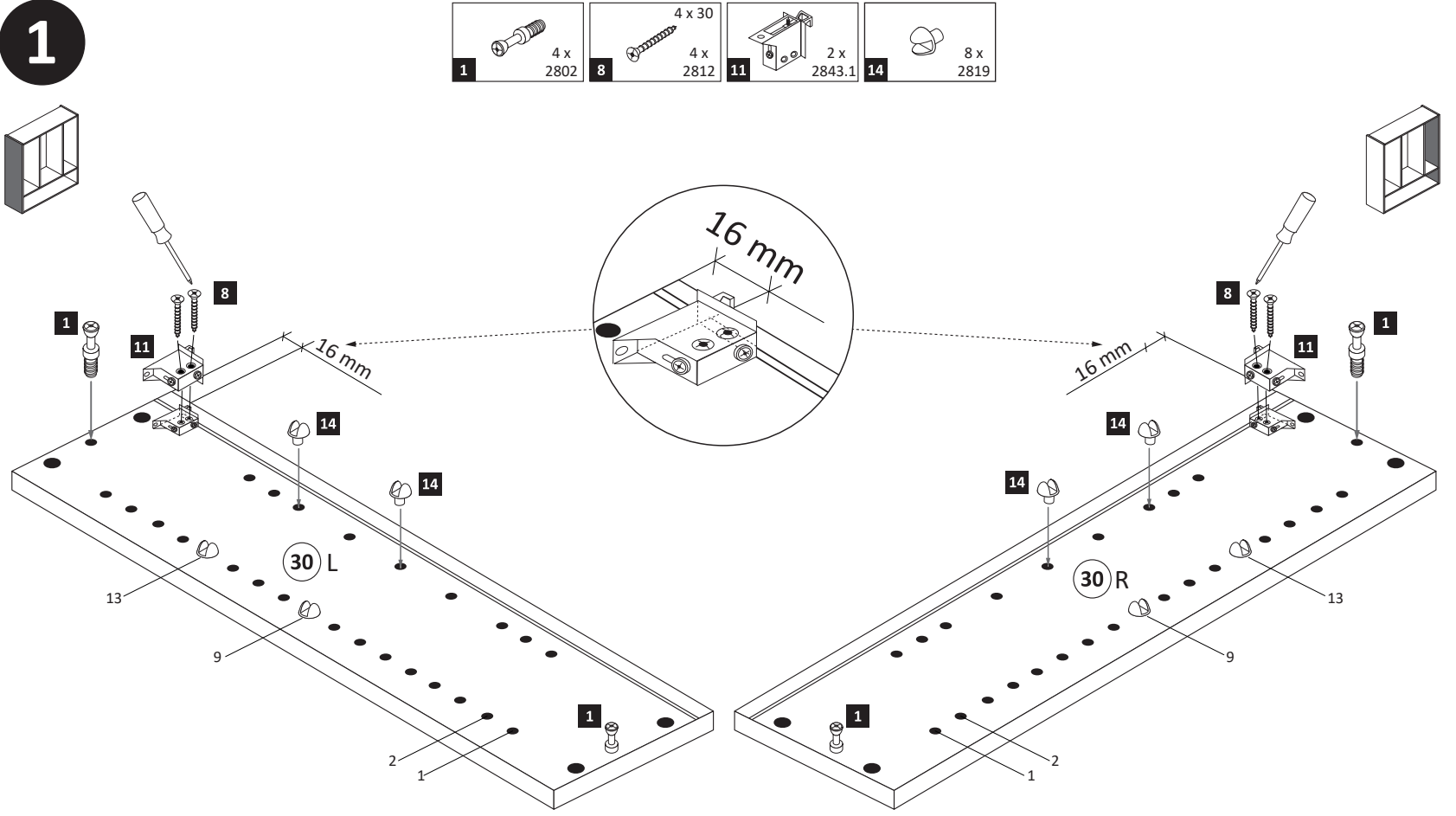
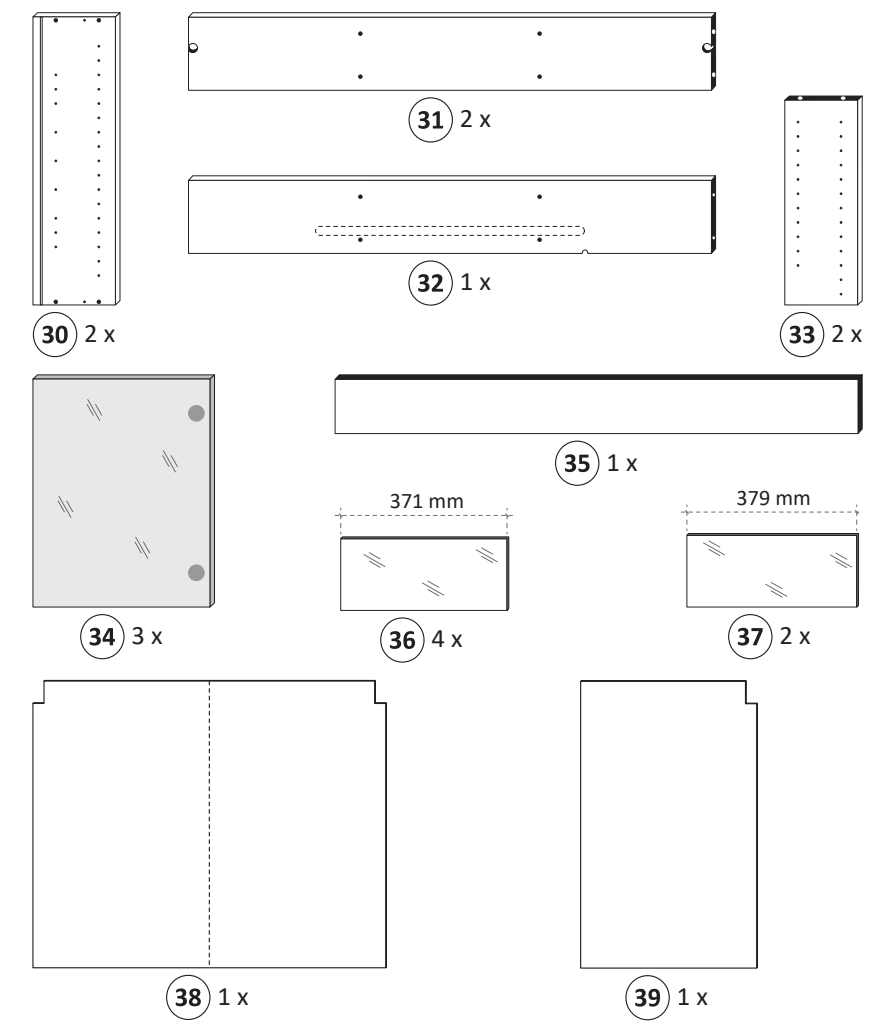

**3**

- 2 4 x 2801
- 7 8 x 30
- 13 1 x 2863
- 18 8 x 2861
- 19 5 x 25
- 1 x 2860
- 1 x 1

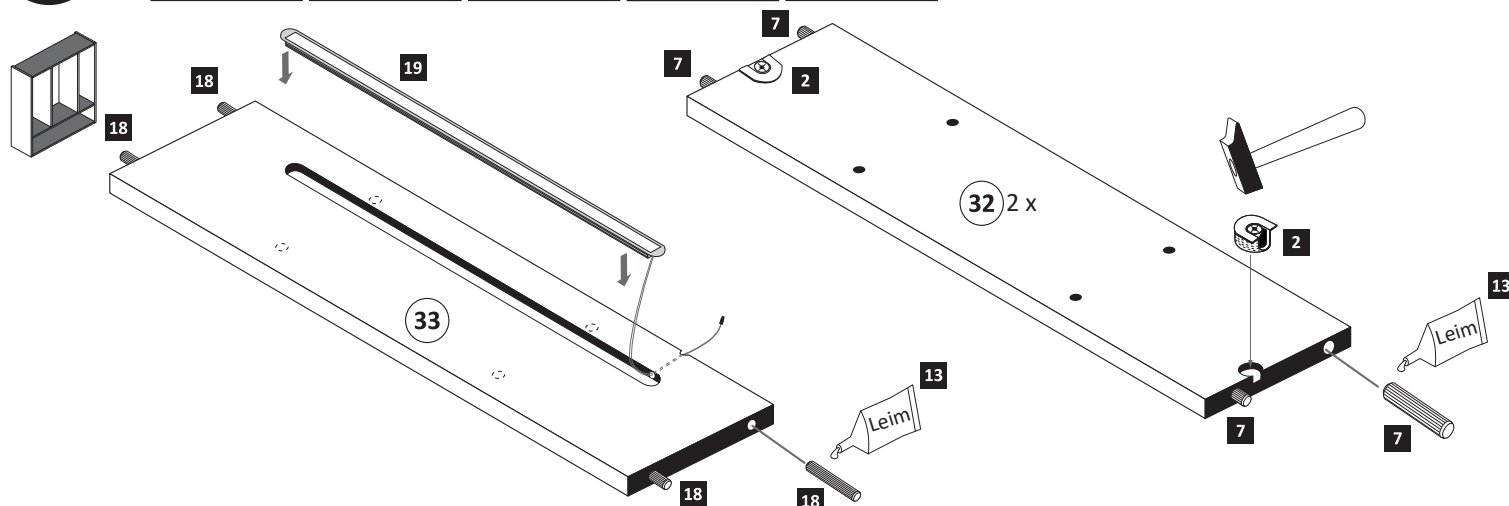

**5**

- 15 1 x 600.00.02

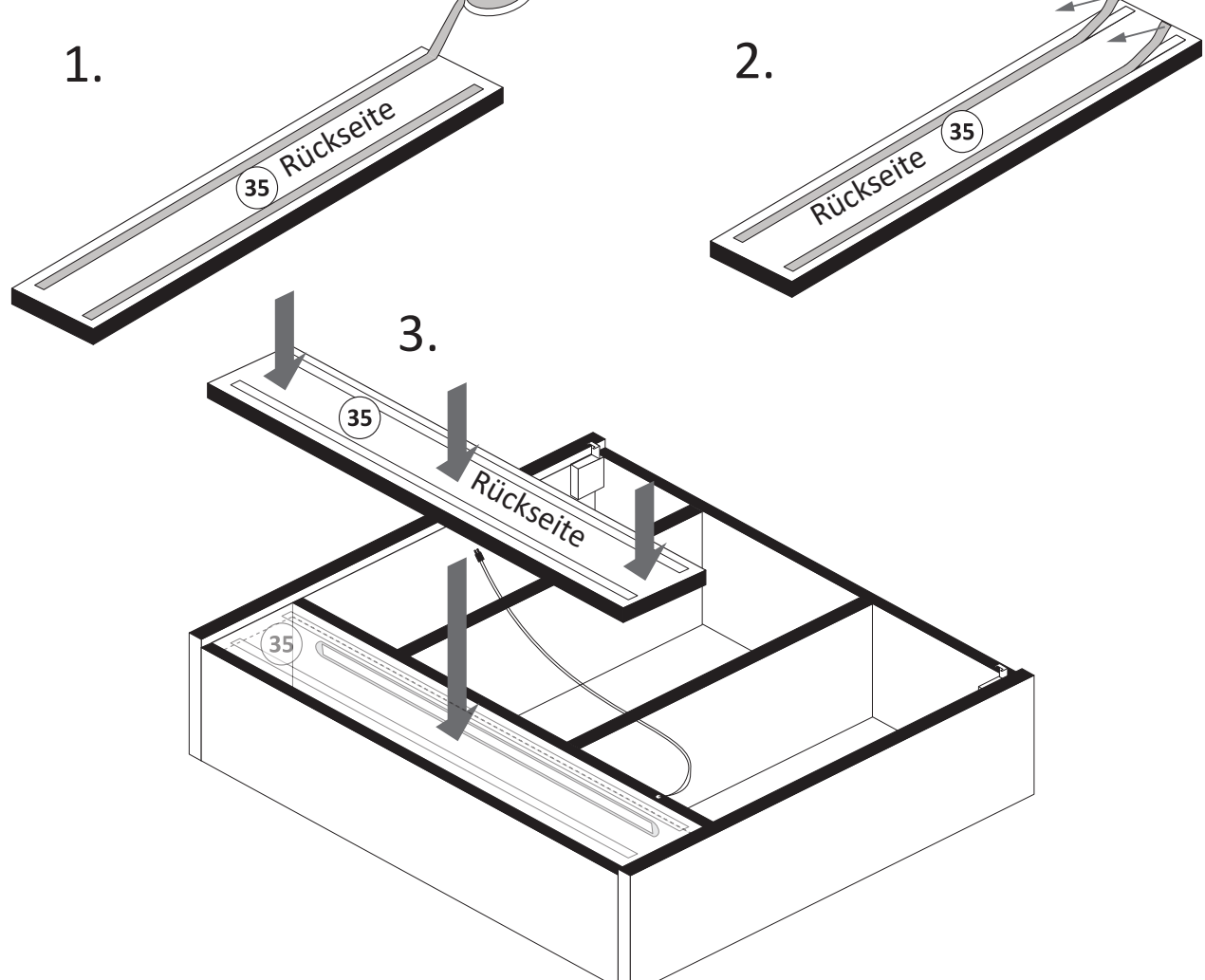

**4**

- 6 2 x 3,5 x 15 2804
- 20 4 x 8mm

- 13 1 x 2863
- D Leim  
 GB Glue  
 NL Lijm  
 PL Klej  
 TR Tutkal  
 F Colle  
 I Colla
- 20 min.

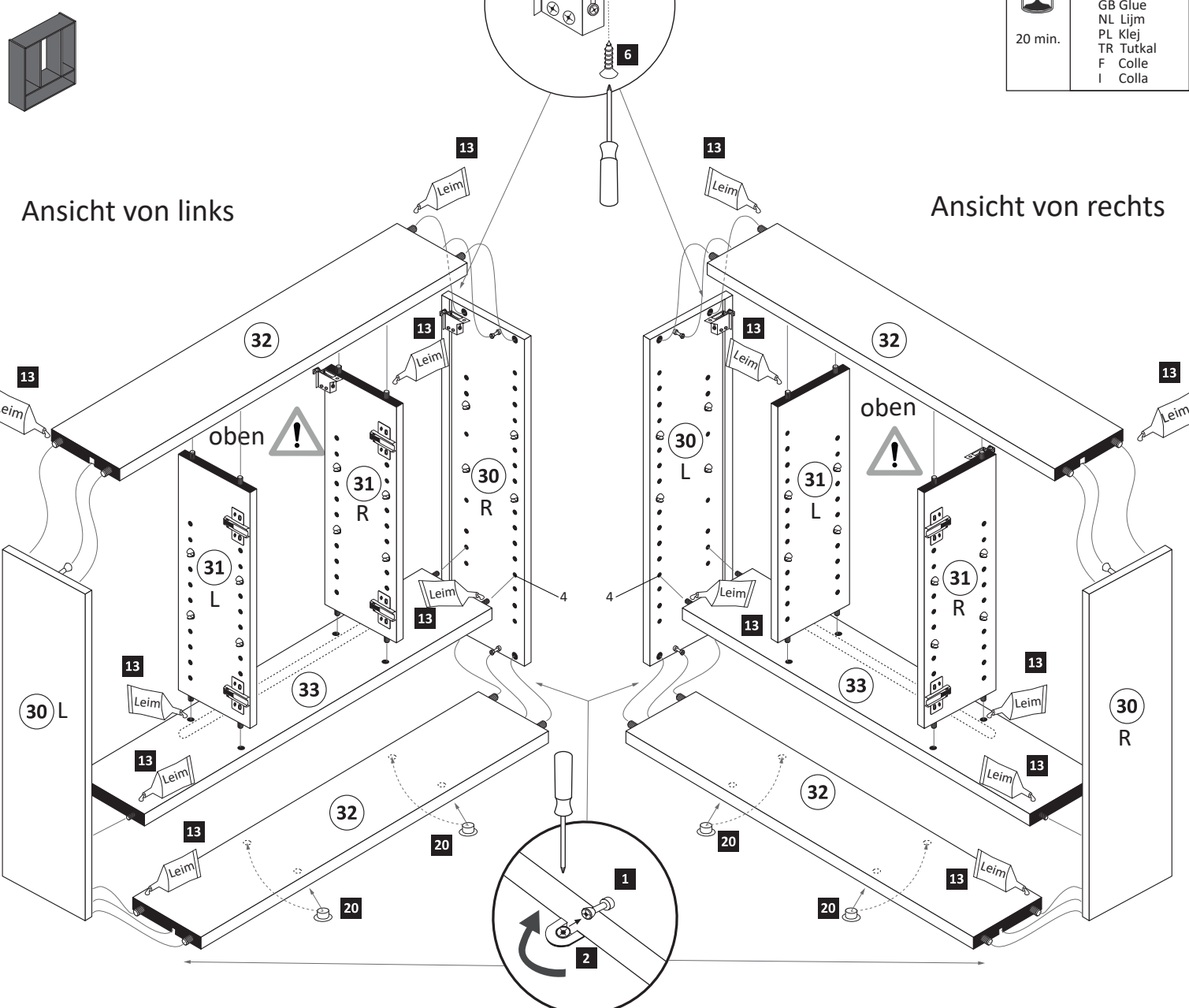

**6**

- 16 3,5 x 17 20 x 2832
- 17 6 x 2552

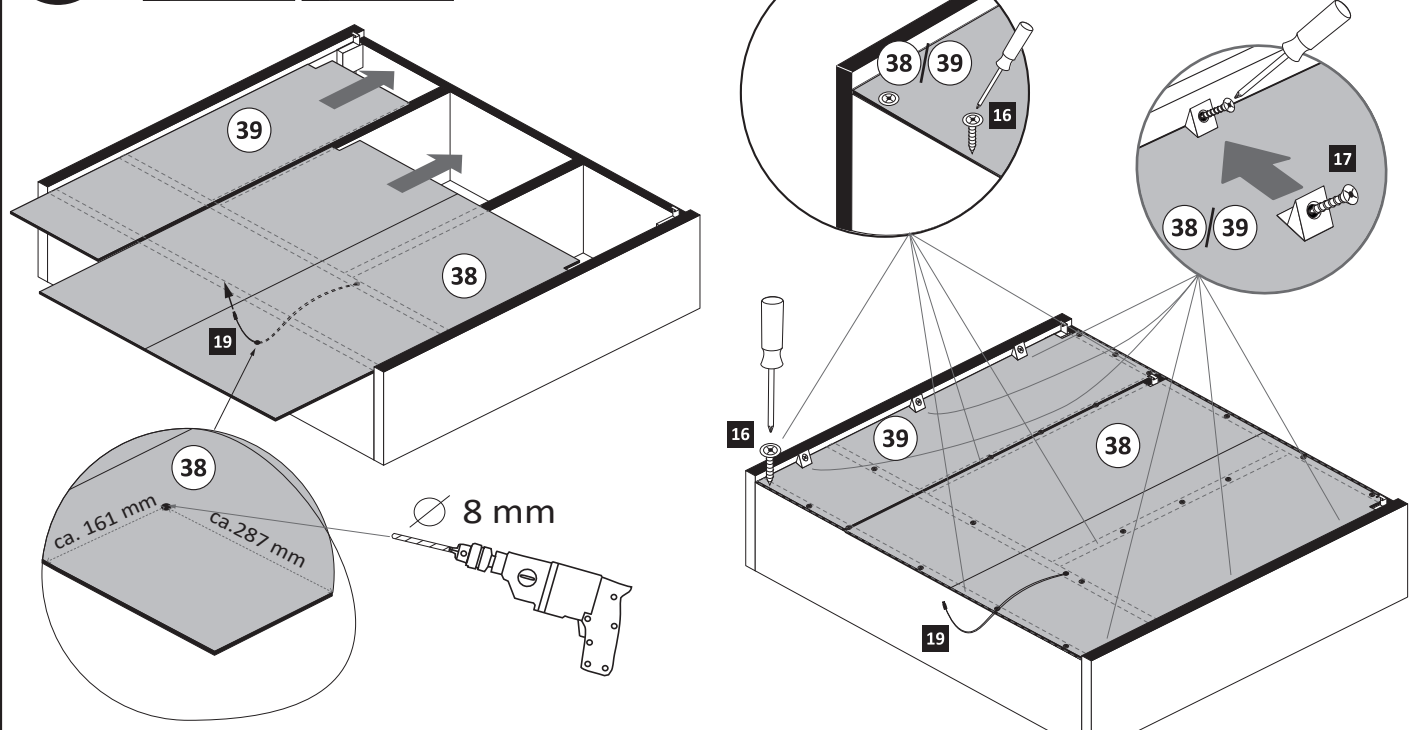

7

Nehmen Sie bitte an dieser Stelle die Montage der Trafos und Aufsatzleuchten vor.

Die Montageanleitung liegt im Zusatzcolli mit dabei!

8

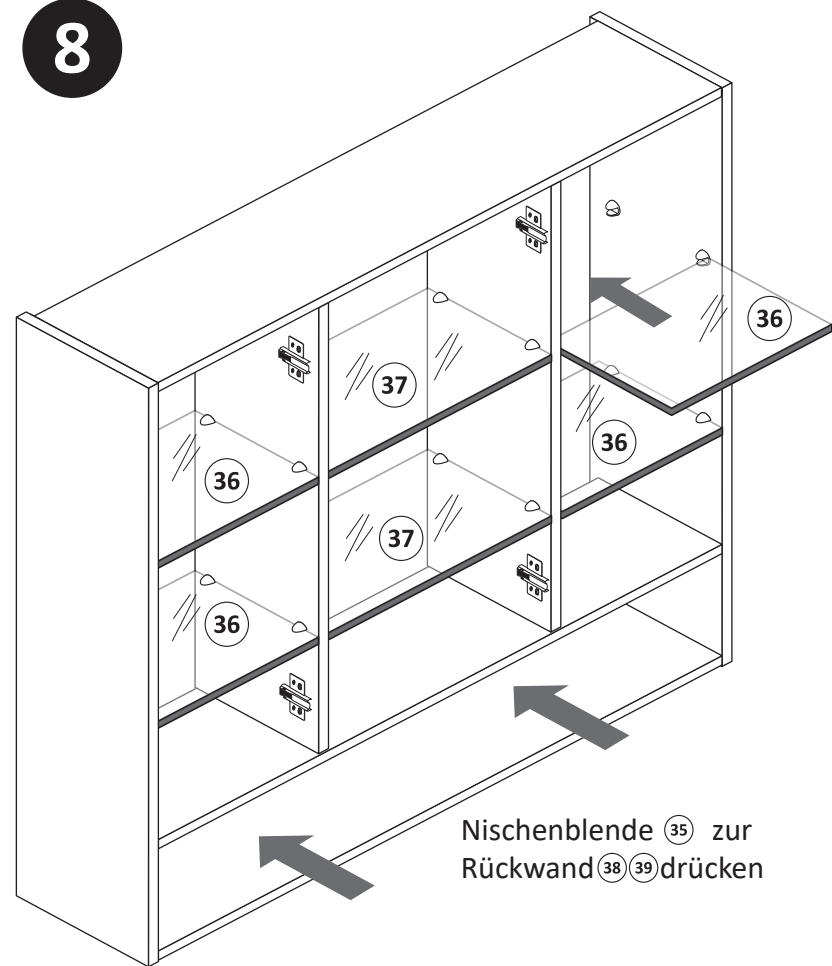

9

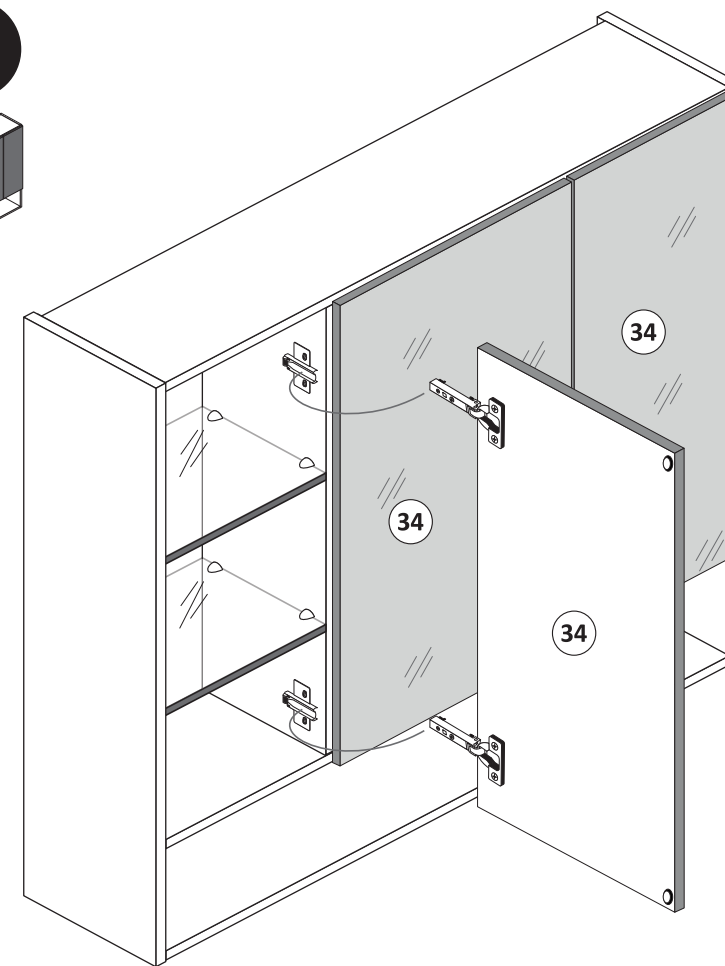
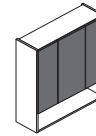

Scharniermontage



Scharnier lösen

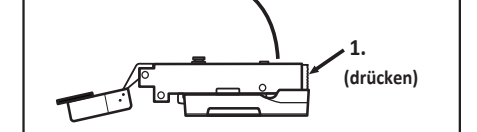

10

gedämpft	ungedämpft	3,5 x 15	
3 x 1506	3 x 1507	12 x 2804	6 x 2865

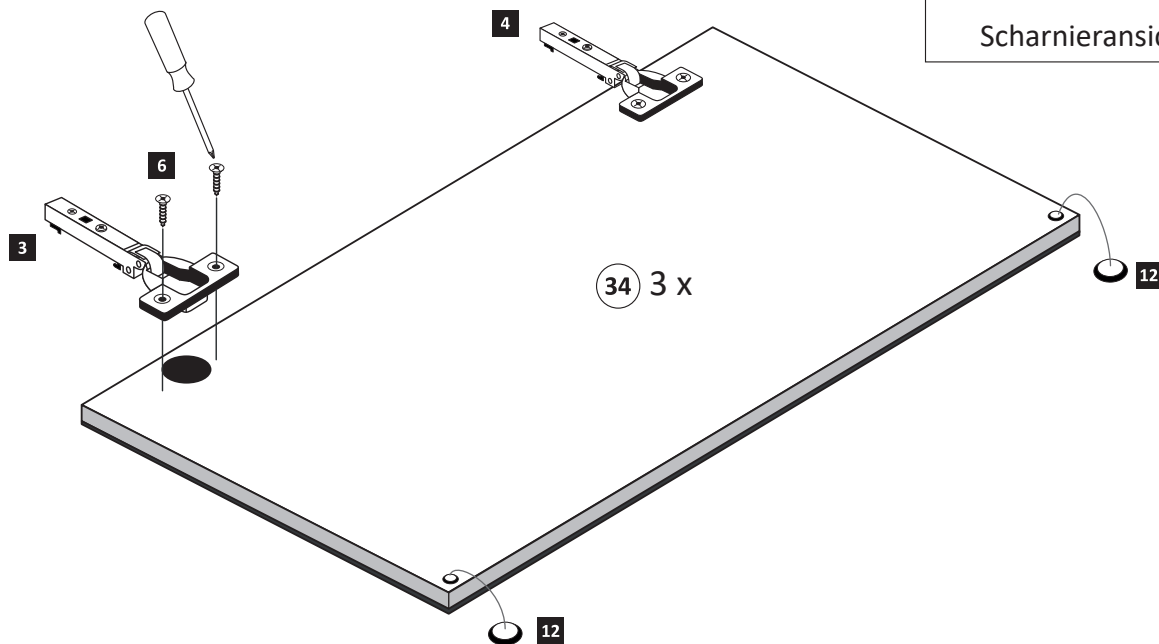
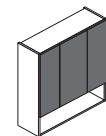

Scharnieransichten von unten

11

5,8 x 55	8 x 30
3 x 2840	3 x 2842

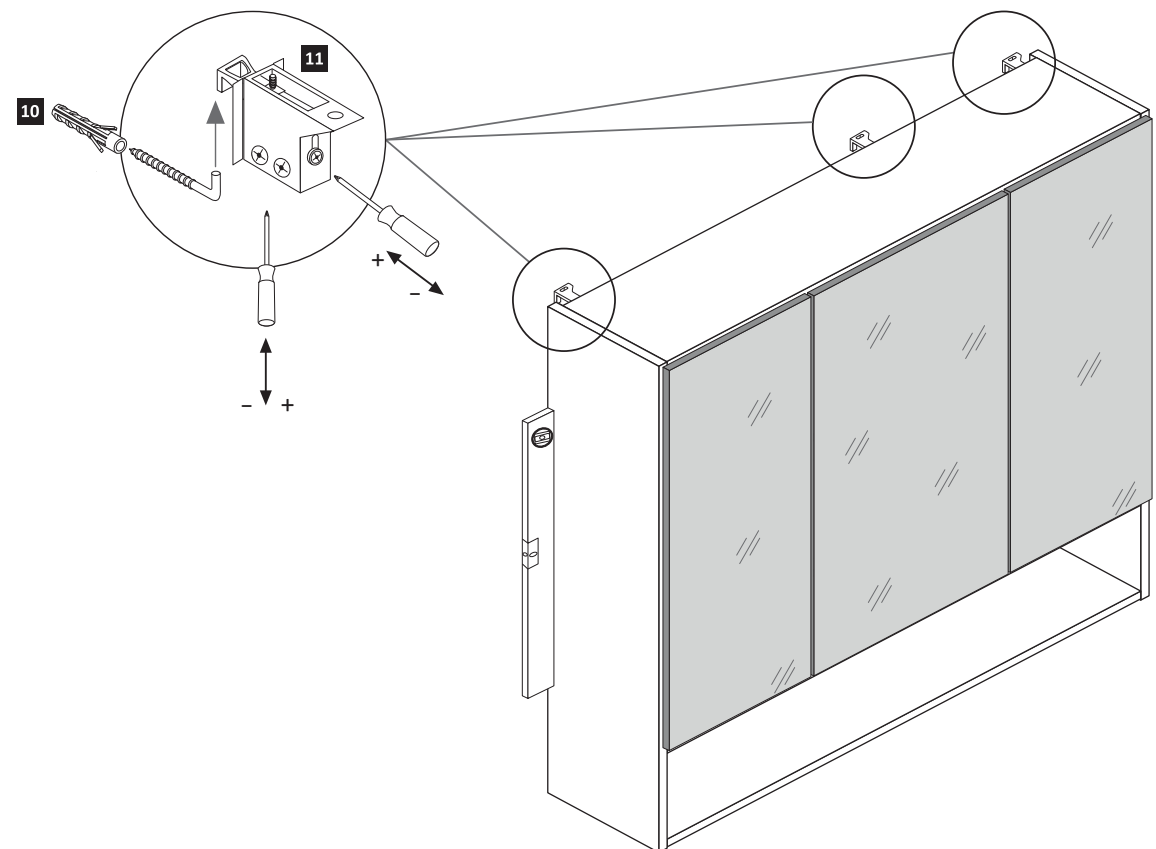



12

3,5 x 15  
12 x  
2804

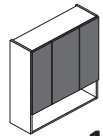

### 1. Türen einstellen.

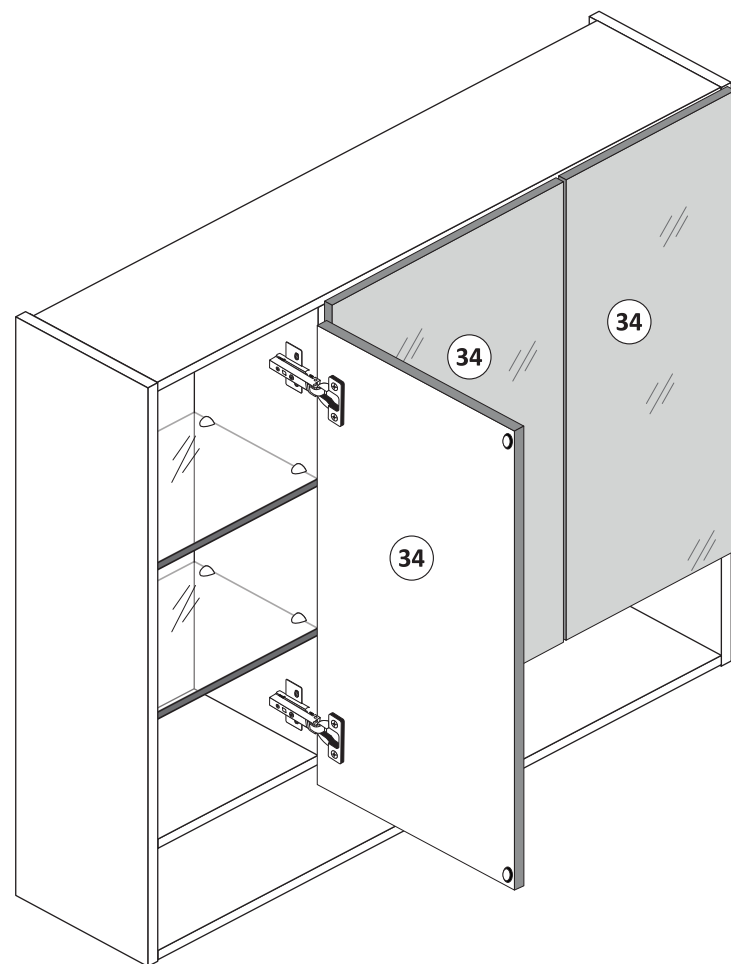
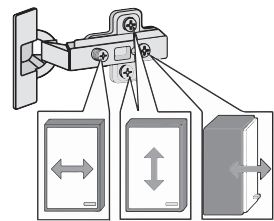

### 2. Sicherungsschrauben montieren.

Aus Sicherheitsgründen ist die Montage der Sicherungsschrauben zwingend notwendig. Nachdem montieren der Sicherungsschrauben ist die Höheneinstellung der Türen nicht mehr möglich!

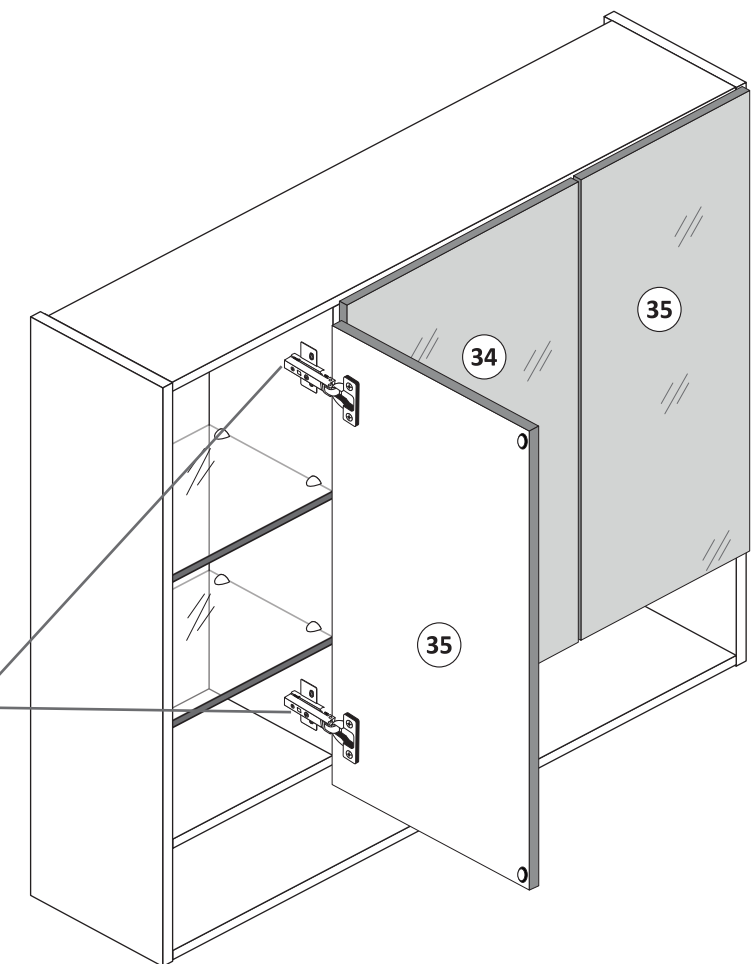
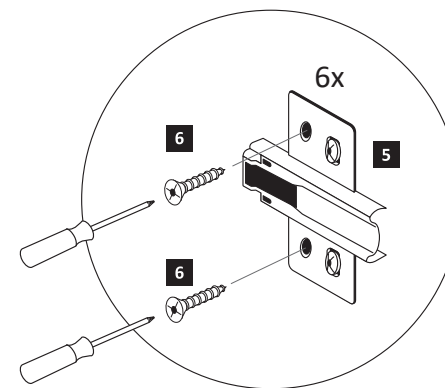



89941.332

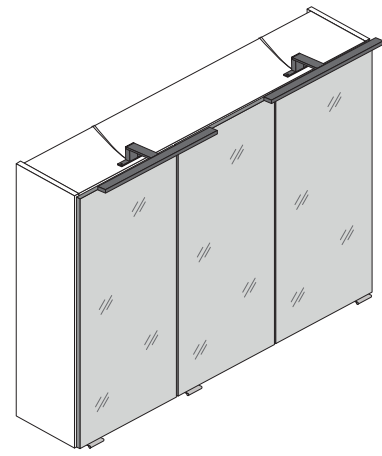
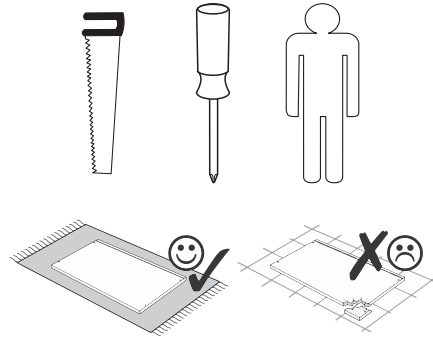

Variante A

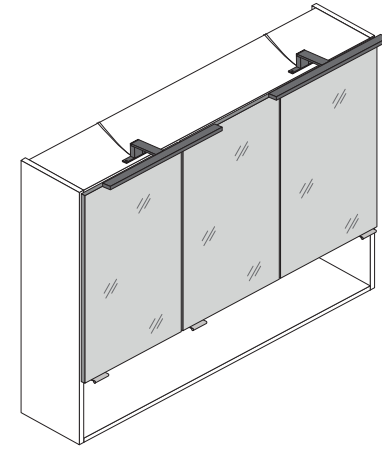

Variante B

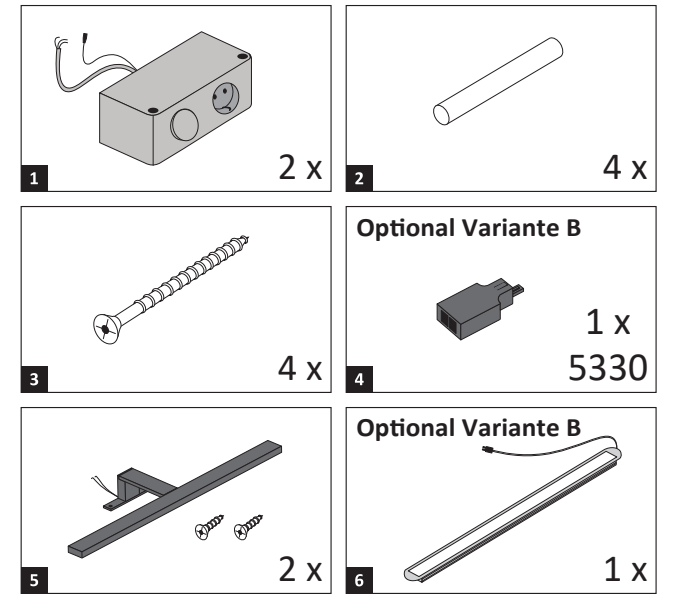

1

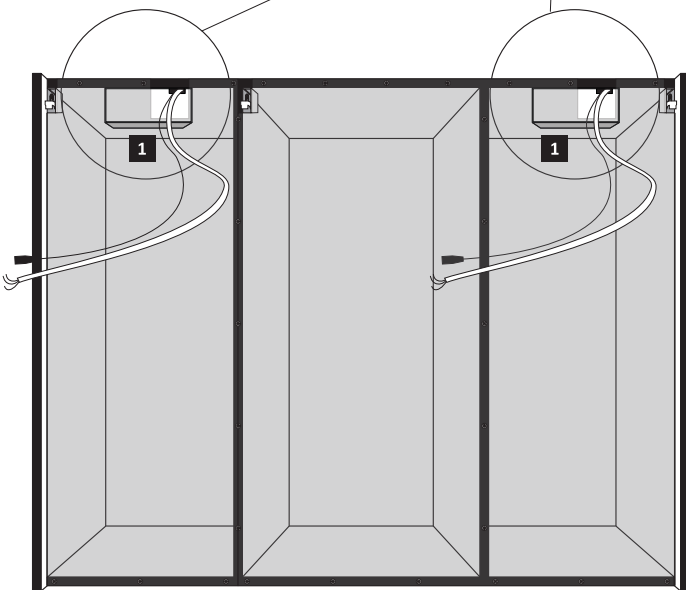
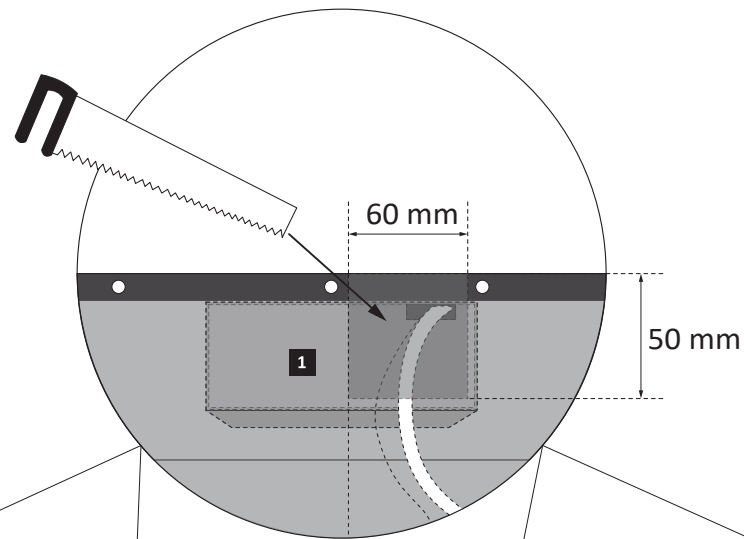

Variante A

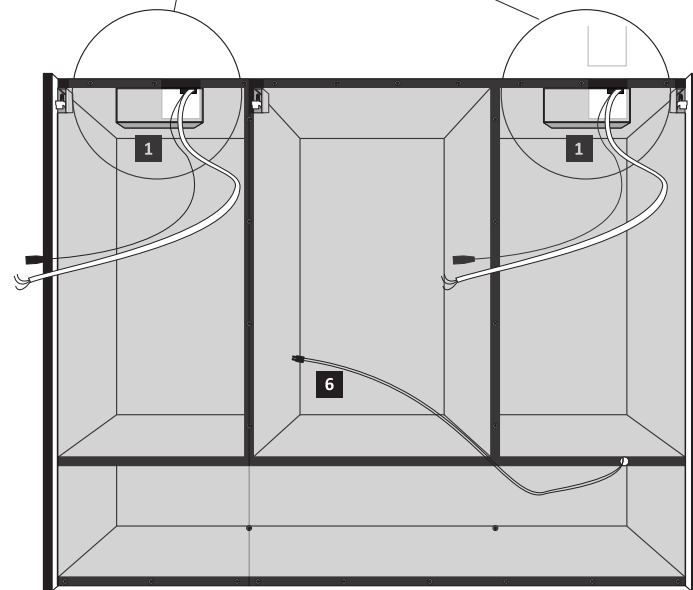

Variante B

2

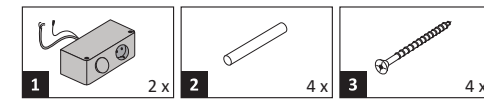

2.

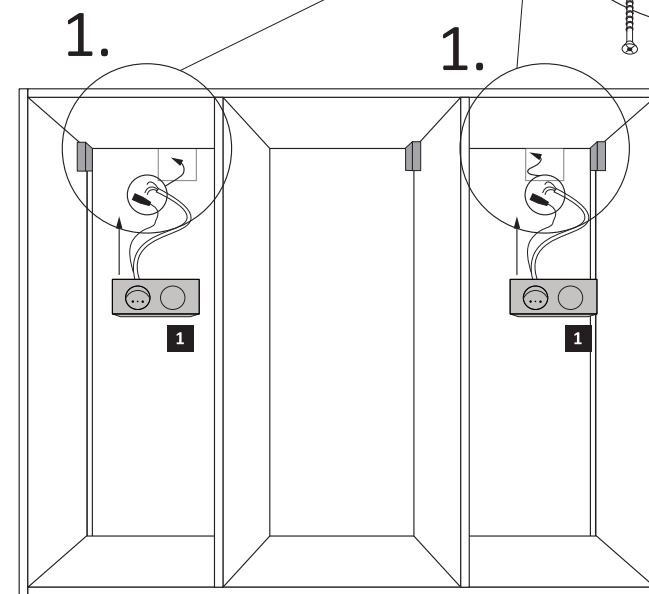
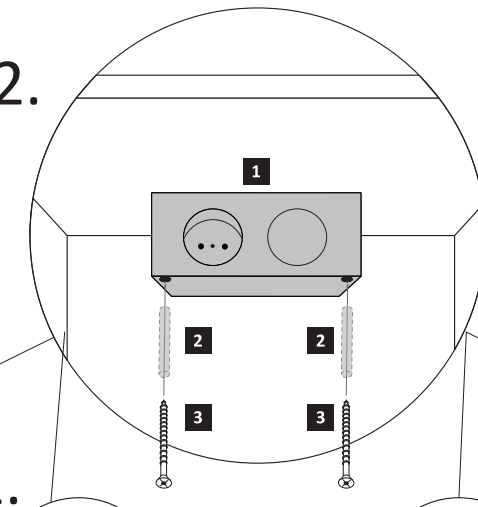

Variante A

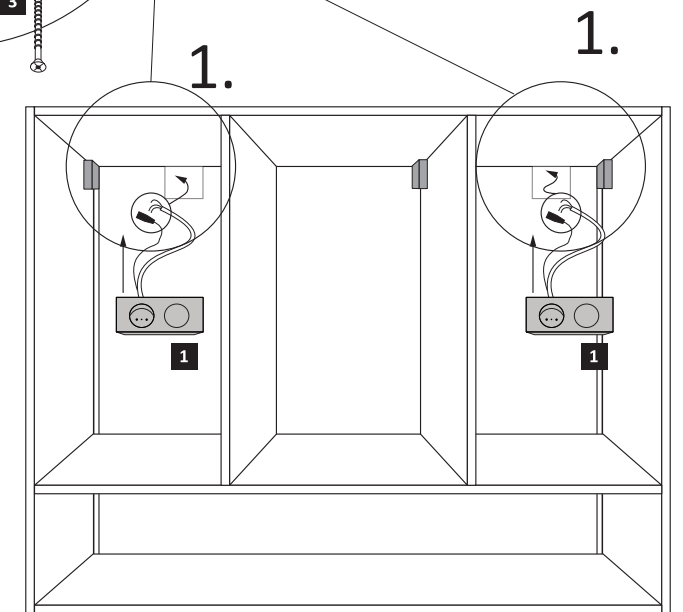

Variante B

3

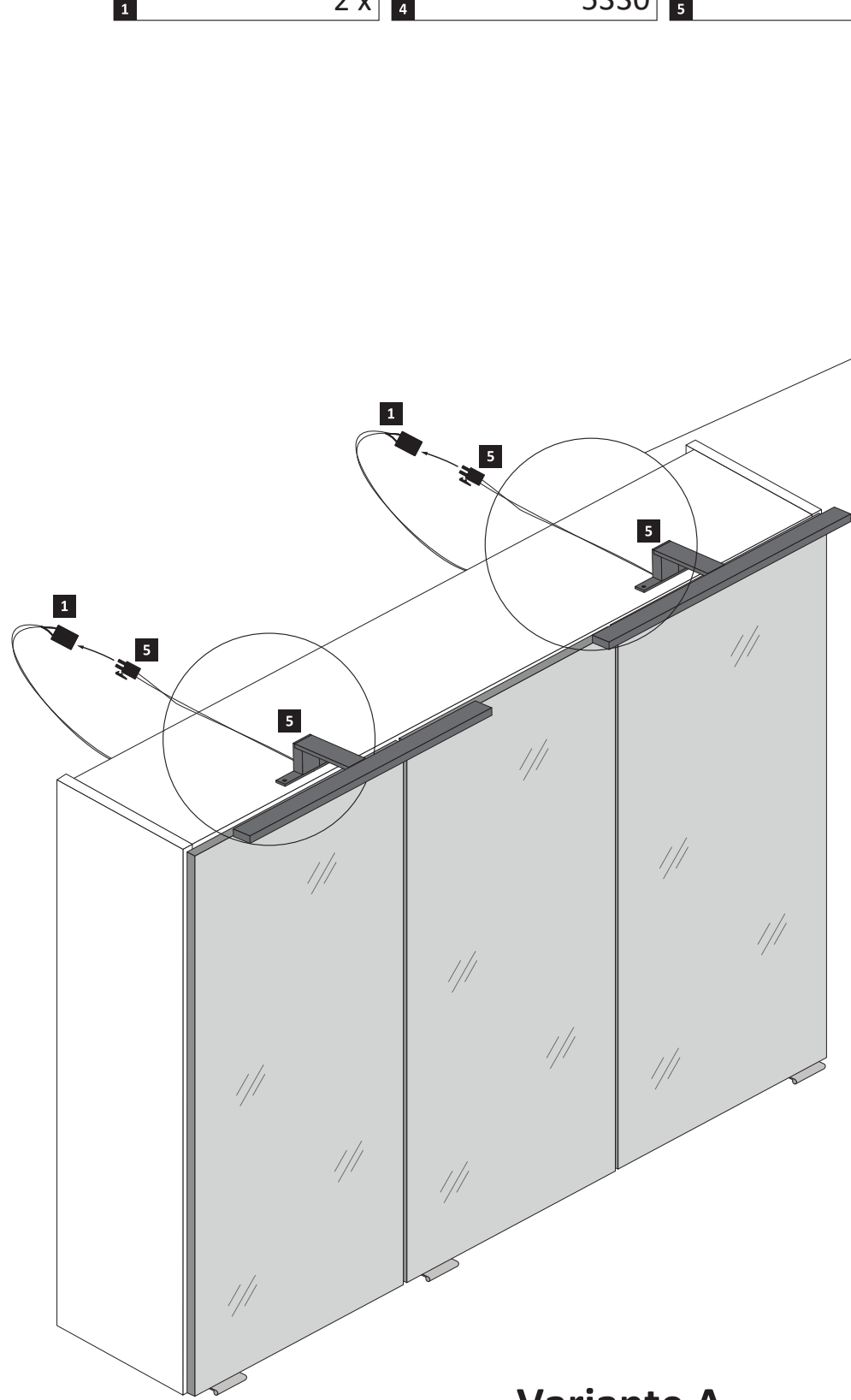
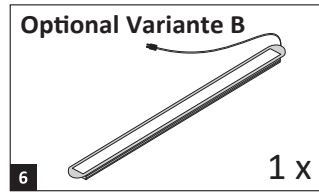
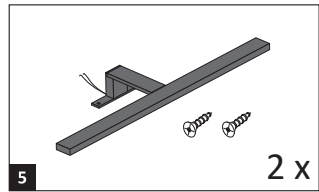
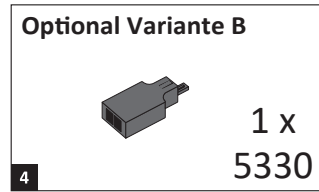
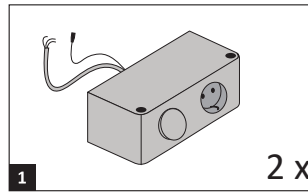

Variante A

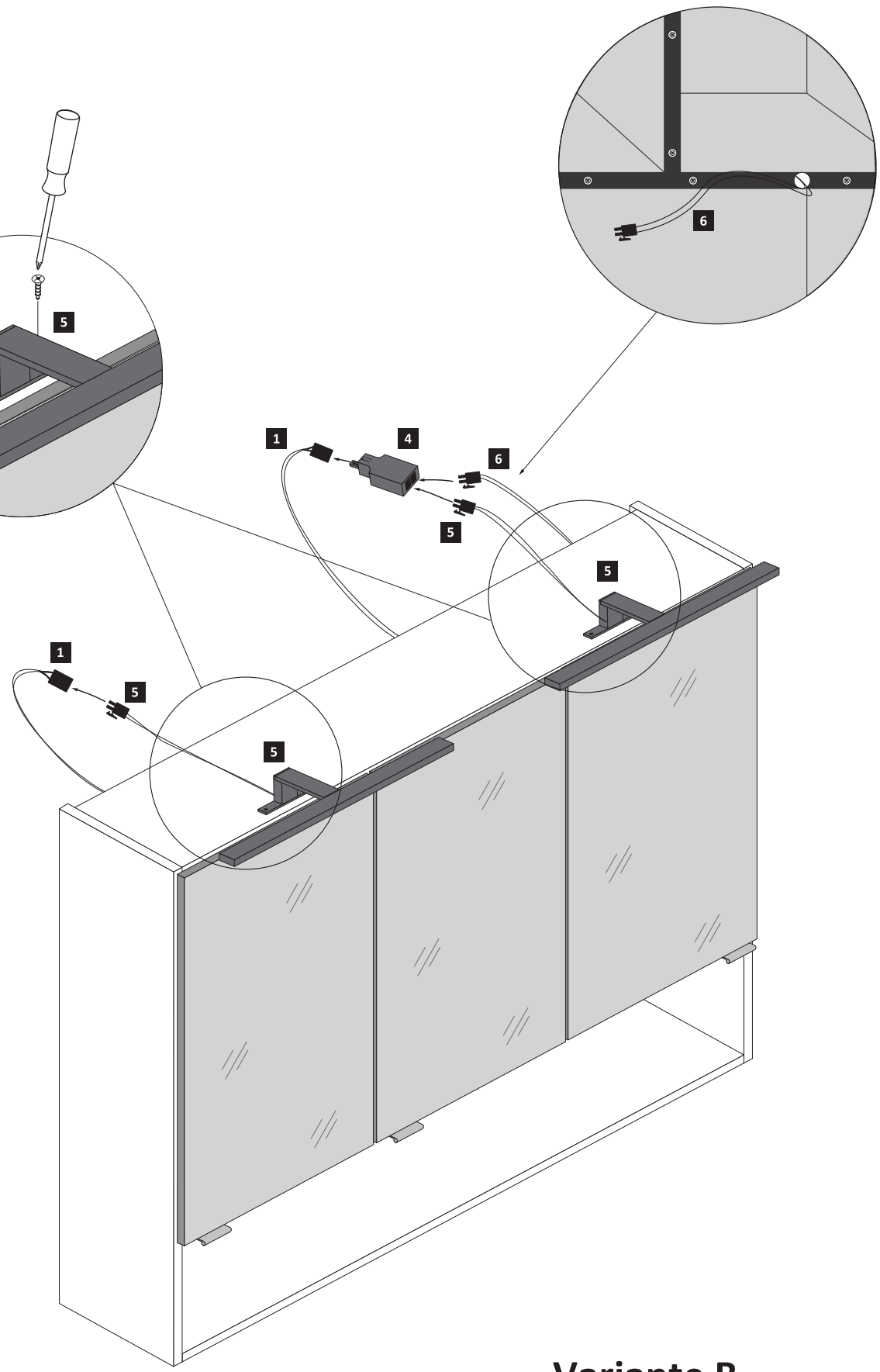

Variante B