

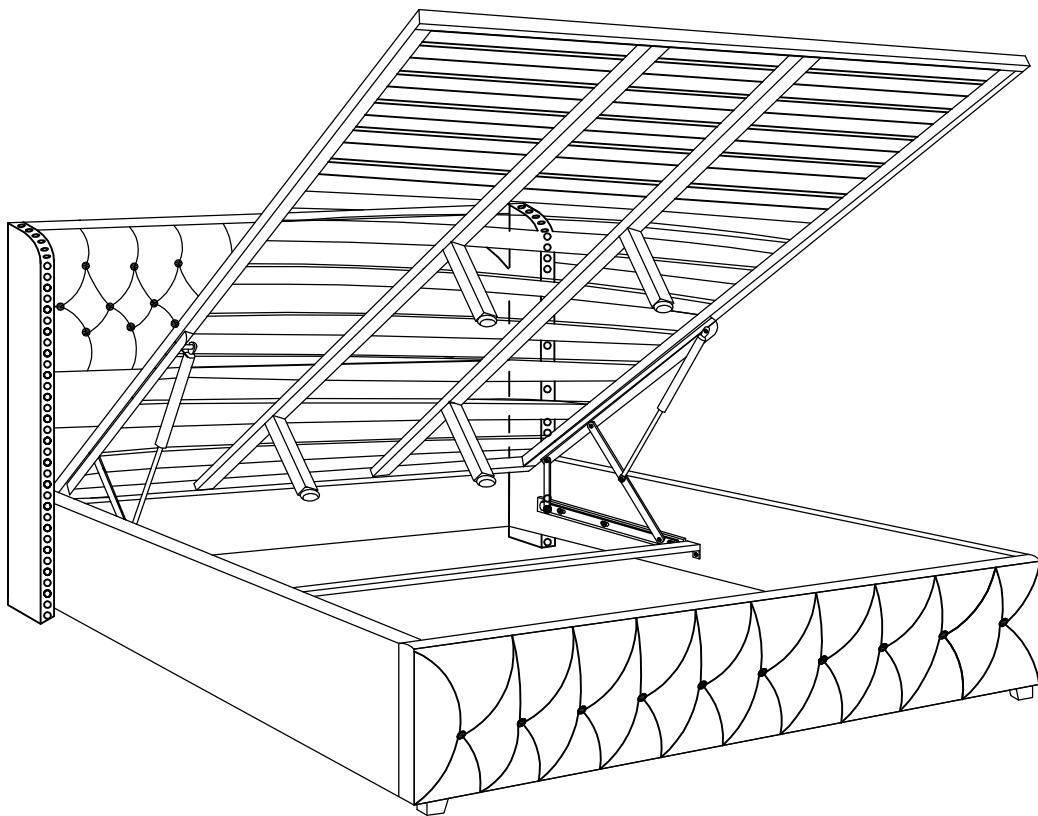







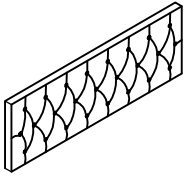
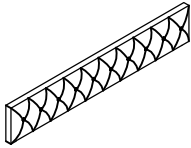
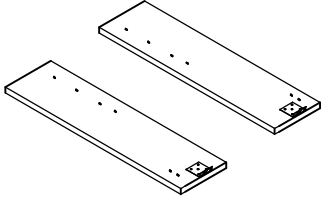
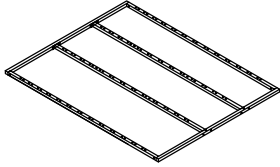
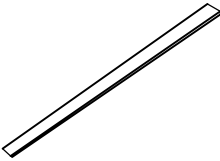

# MONTAGEANLEITUNG

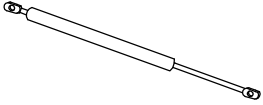
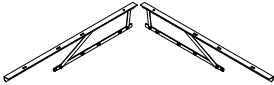
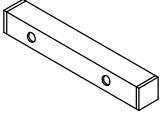
## WICHTIGER HINWEIS:

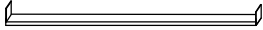
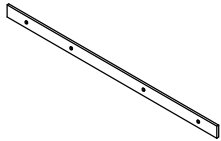
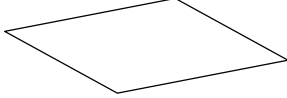

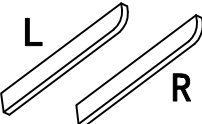

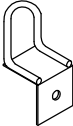



- ※ LEGEN SIE ALLE TEILE AUF EINE SAUBERE UND GLATTE OBERFLÄCHE, Z. B. EINE TEPPICH ODER TEPPICH, UM ZU VERMEIDEN, DASS DIE TEILE ZERKRATZT WERDEN.
- ※ BITTE BEFOLGEN SIE DIE MONTAGEANLEITUNG SCHRITT FÜR SCHRITT.
- ※ ZIEHEN SIE NICHT ALLE SCHRAUBEN AN, BIS DAS BETT VOLLSTÄNDIG EINGERICHTET IST.

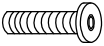
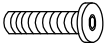
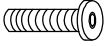
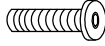

## Parts List

<b>1:HEAD BOARD 1PC</b> 	<b>2:FOOT BOARD 1PC</b> 	<b>3:SIDE RAIL 2PCS</b> 	<b>4:BEDSTEAD KD 1SETS</b> 	
<b>5:SLAT 12PCS</b> 	<b>6:ANGLE IRON 2PCS</b> 	<b>7:STEAM MOVING BAR2PCS (ASSEMBLED WITH H ALREADY)</b> 	<b>8:STEAM MOVING MECHANICA 2PCS</b> 	<b>9:SQUARE TUBE 1PC</b> 
<b>10: LEG 4PCS</b> 	<b>11 : 1PC</b> 	<b>12 : 2PCS</b> 	<b>13 : Non-Woven Bed Base 1PC</b> 	<b>14: LEG 2PCS</b> 
<b>15:WINGS 2PCS</b> 	<b>16: 1PC</b> 	<b>17:ANGLE IRON 2PCS</b> 	<b>18:SLAT CAP 24PCS</b> 	

## Hardware List

<b>A:BOLT 28PCS</b>  5/16X50mm	<b>B:BOLT 14PCS</b>  5/16X35mm	<b>C:BOLT 9PCS</b>  1/4X35mm	<b>D:BOLT 12PCS</b>  1/4X15mm	<b>E:SPRING WASHER 40PCS</b>  5/16	<b>F:FLAT WASHER 40PCS</b>  5/19 x19mm
<b>G:FLAT WASHER 20PCS</b>  1/4x16mm	<b>H:ALLEN KEY 1PC</b>  5/16	<b>I:ALLEN KEY 1PC</b>  1/4	<b>J:SPANNER 1PC</b>  5/16	<b>K:NUT 20PCS</b>  5/16	

## SCHRITT 1

**B**  4PCS

**E**  4PCS

**F**  4PCS

**H**  1PC

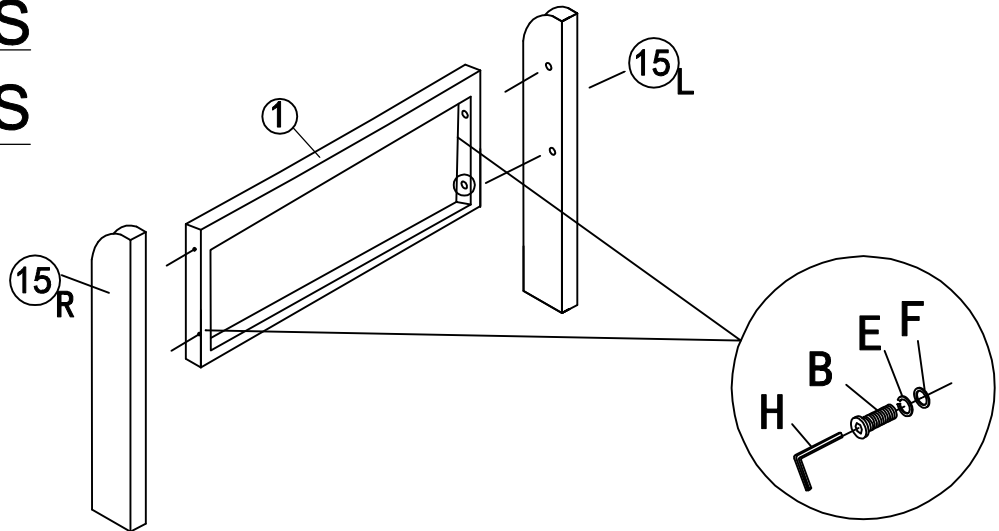

## SCHRITT 2

**A**  2PCS

**E**  2PCS

**F**  2PCS

**H**  1PC

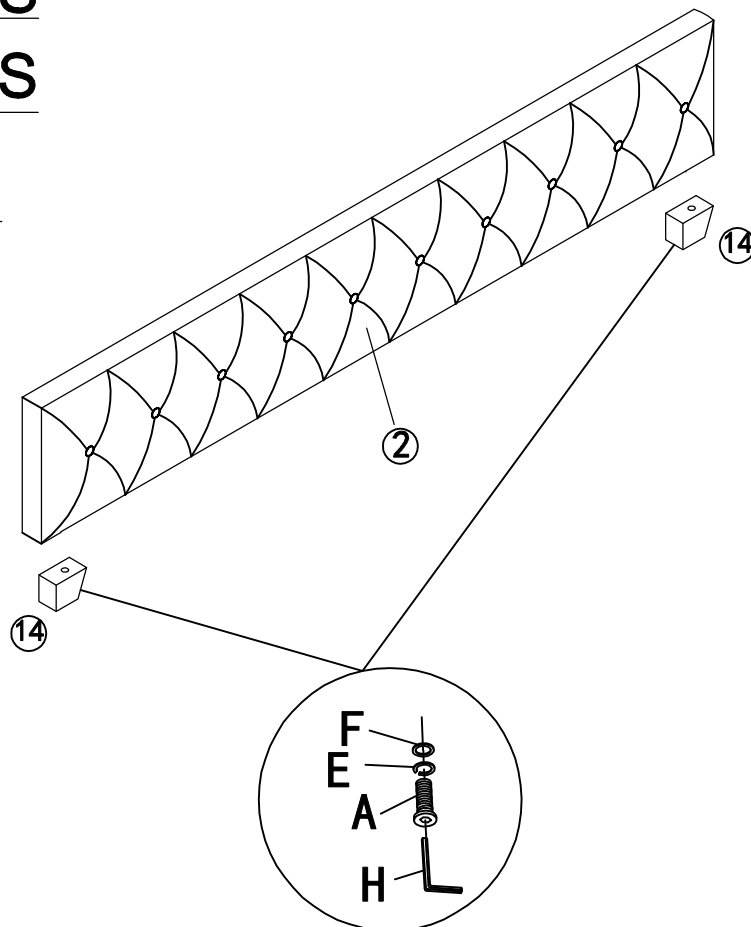

### SCHRITT 3

**B**  4PCS

**E**  4PCS

**F**  4PCS

**H**  1PC

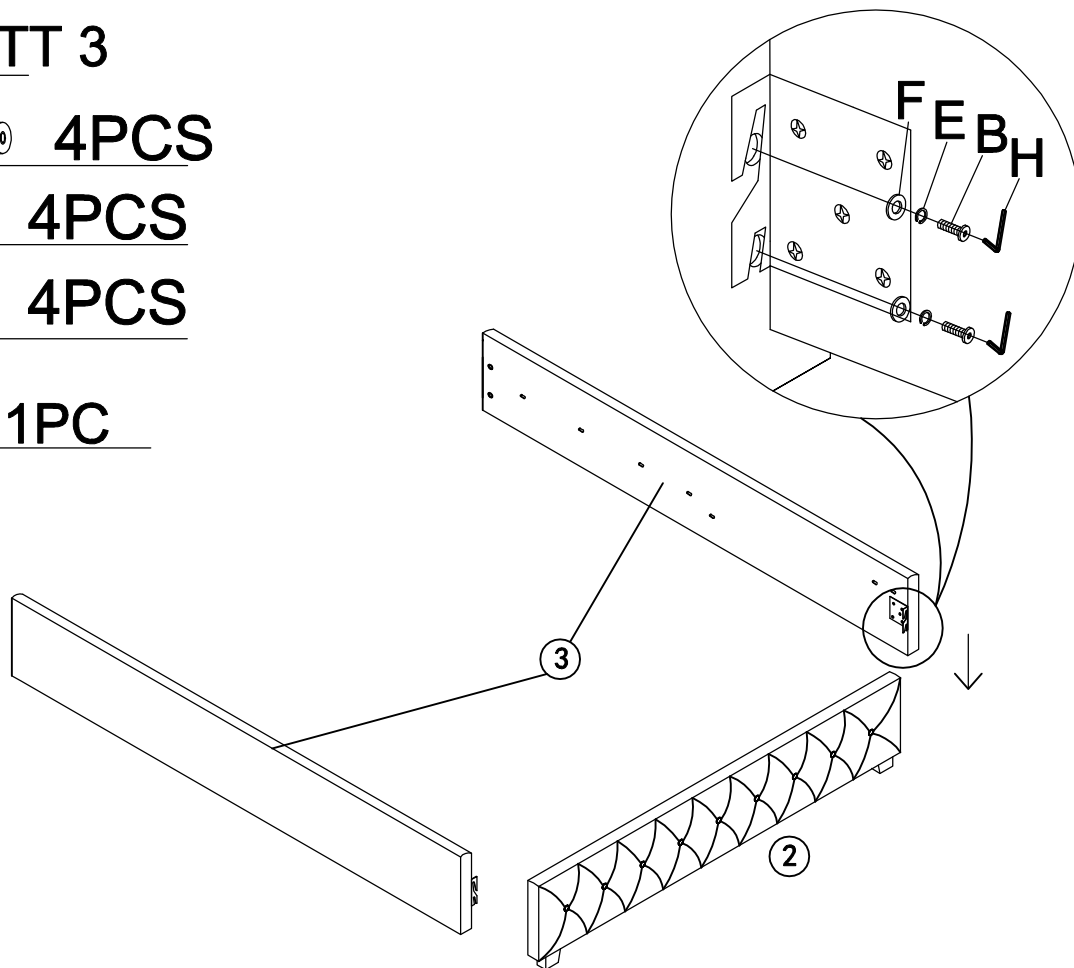

### SCHRITT 5

**B**  4PCS

**E**  4PCS

**F**  4PCS

**H**  1PC

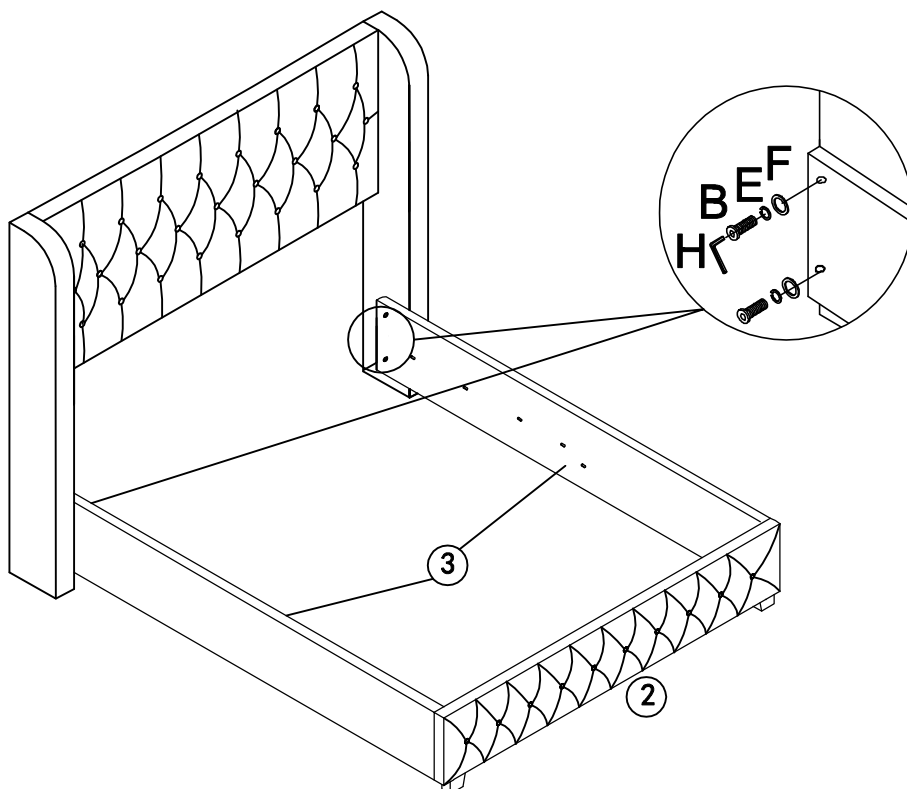



## SCHRITT 6

D  8PCS

G  8PCS

6  2PCS

I  1PC

9  1PC

A  2PCS

E  2PCS

F  2PCS

H  1PC

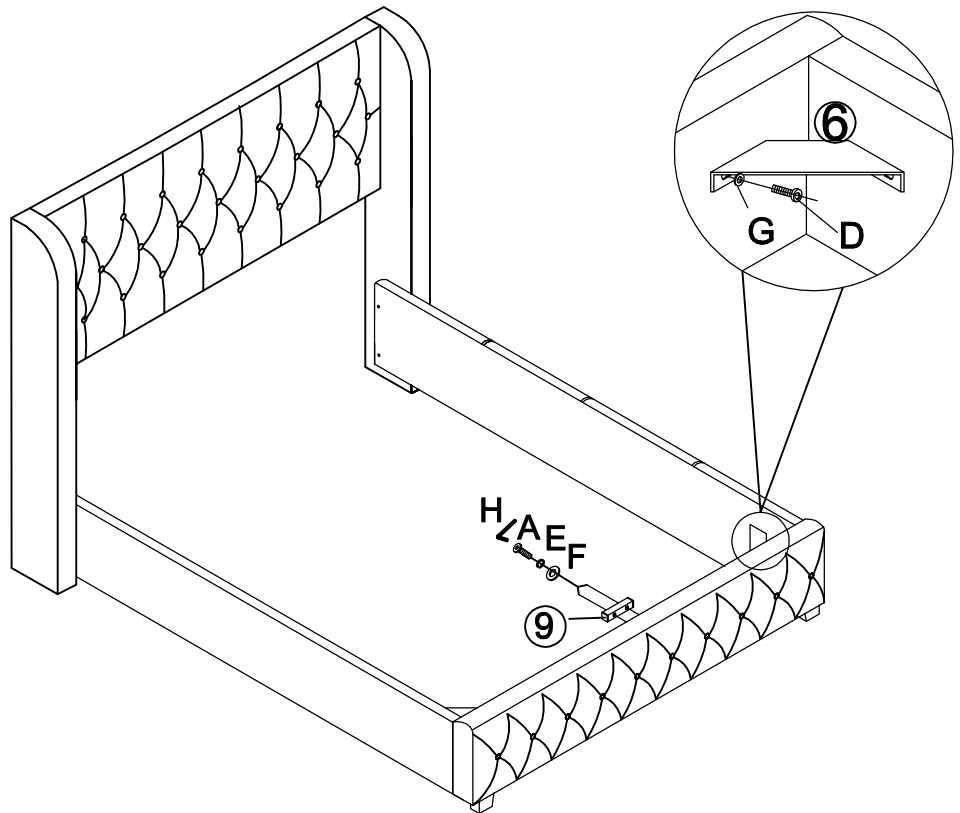

## SCHRITT 7

C  8PCS

G  8PCS

I  1PC

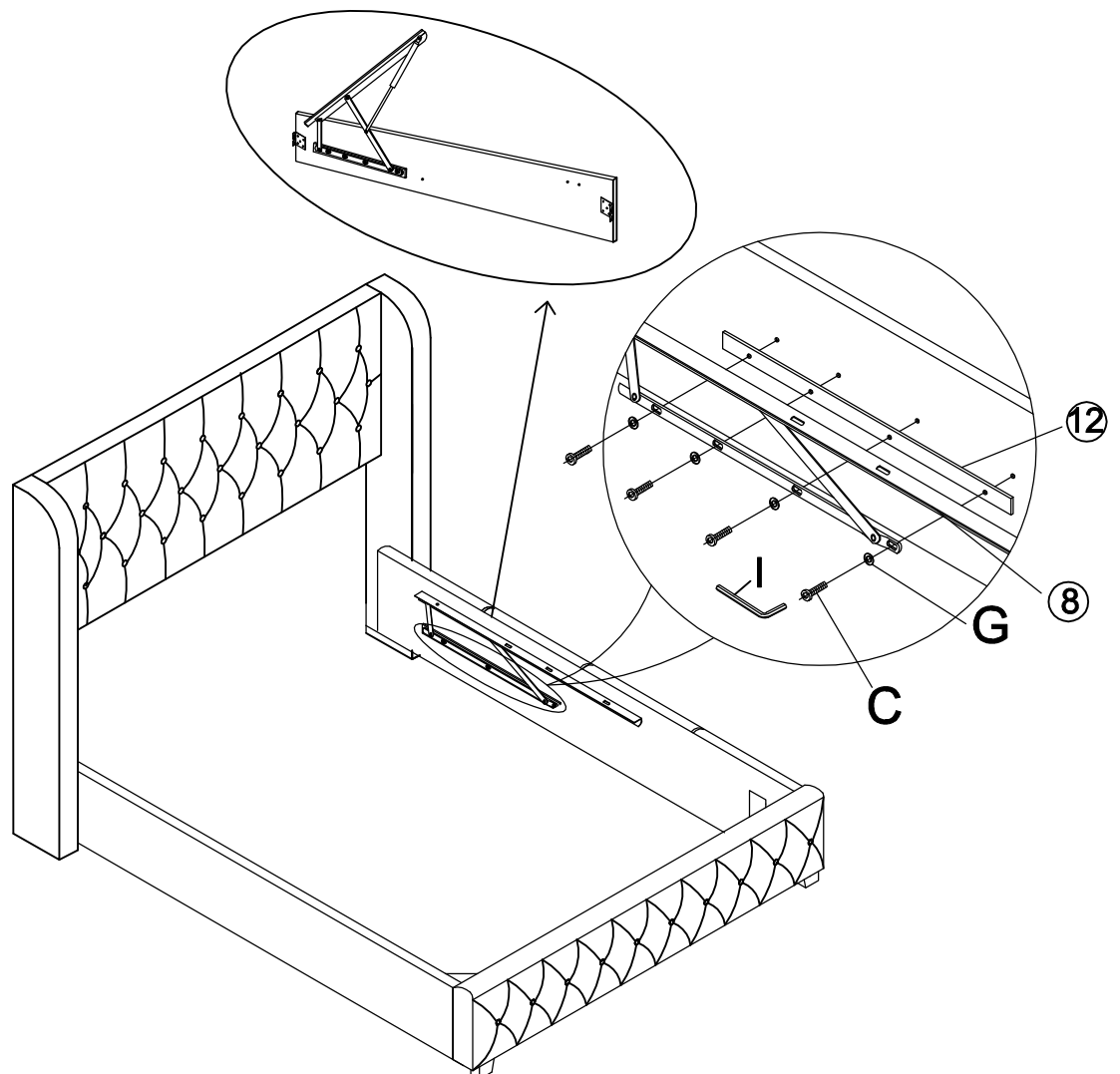

# SCHRITT 8

D  2PCS

G  2PCS

I  1PC

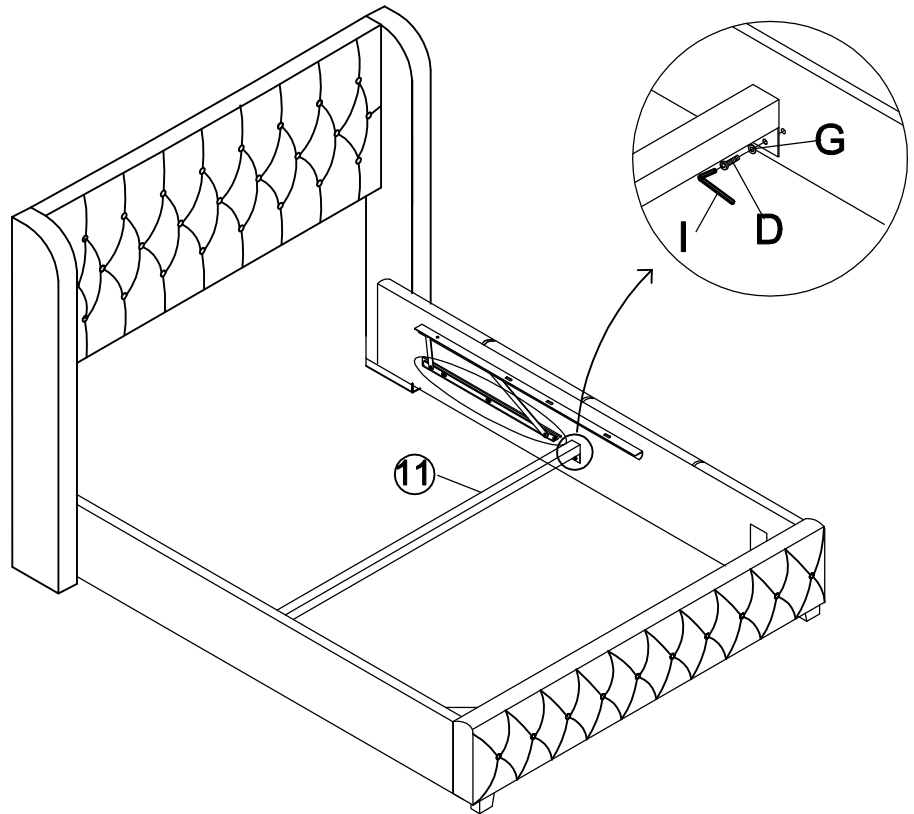

# SCHRITT 9

A  14PCS

E  14PCS

F  14PCS

K  14PCS

J  1PC

17  2PCS

16  1PCS

H  1PC

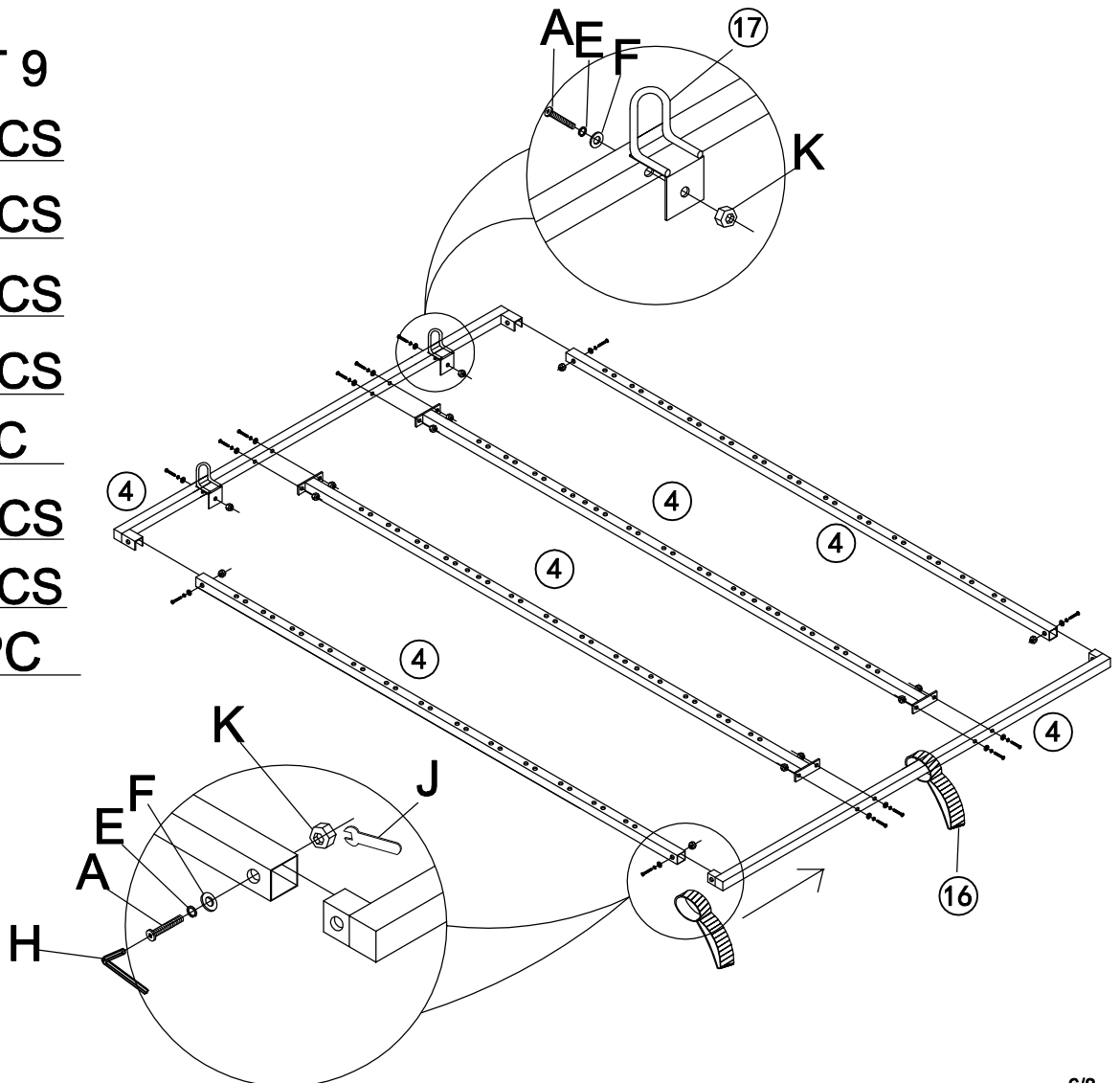

## SCHRITT 10

A  8PCS

E  8PCS

F  8PCS

K  4PCS

H  1PC

J  1PC

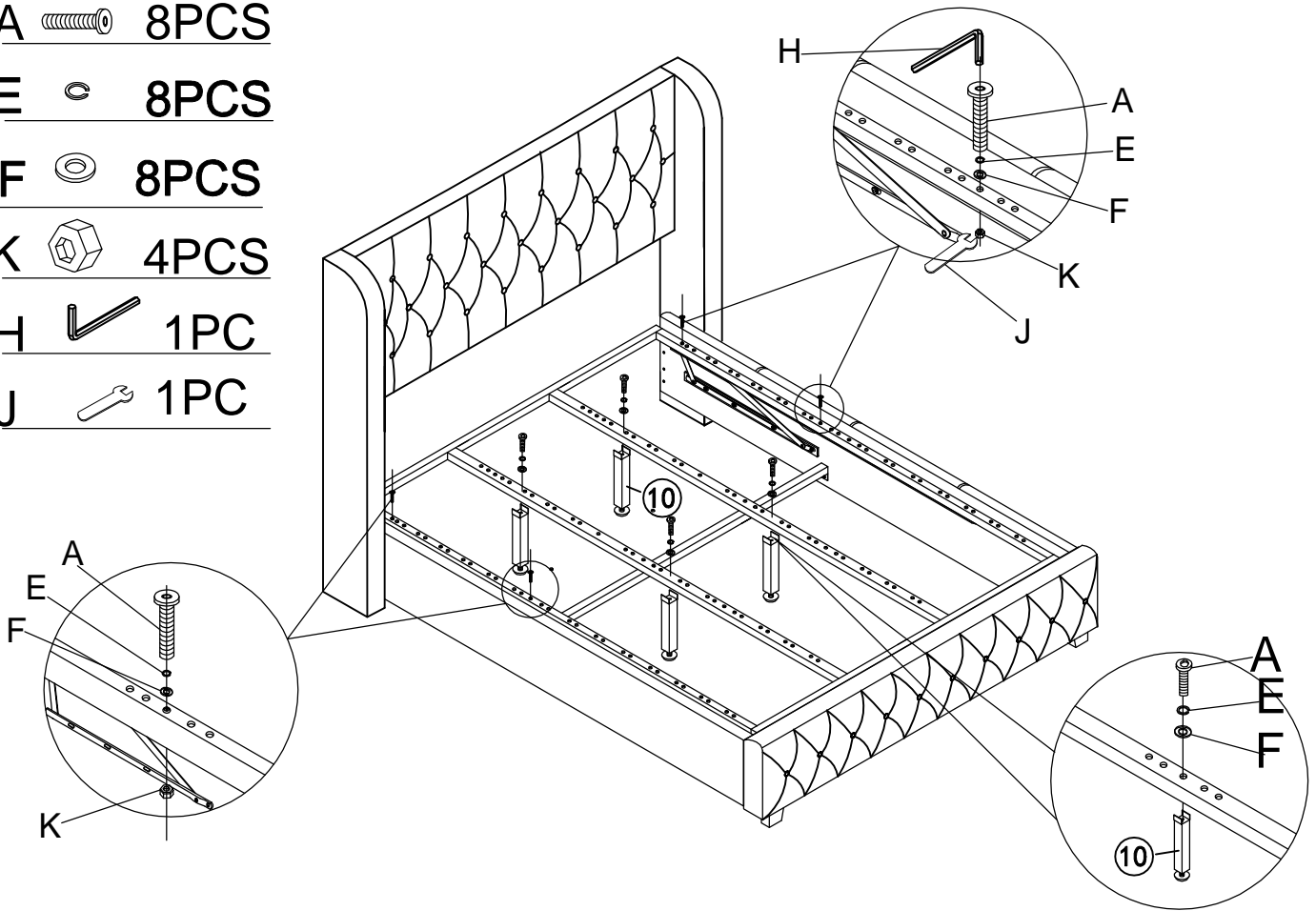

## SCHRITT 11

22  24PCS

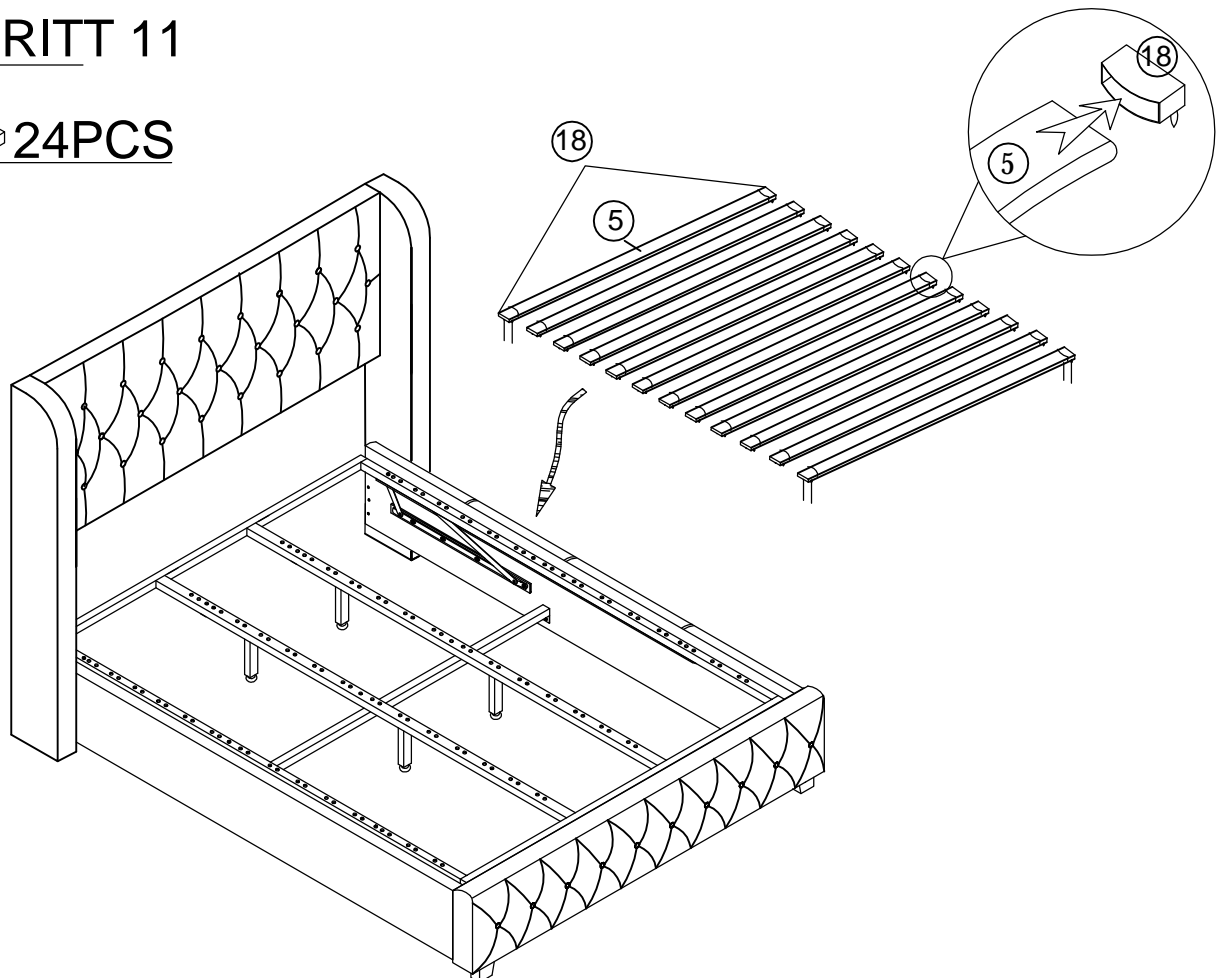

# SCHRITT 12

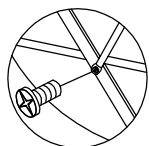
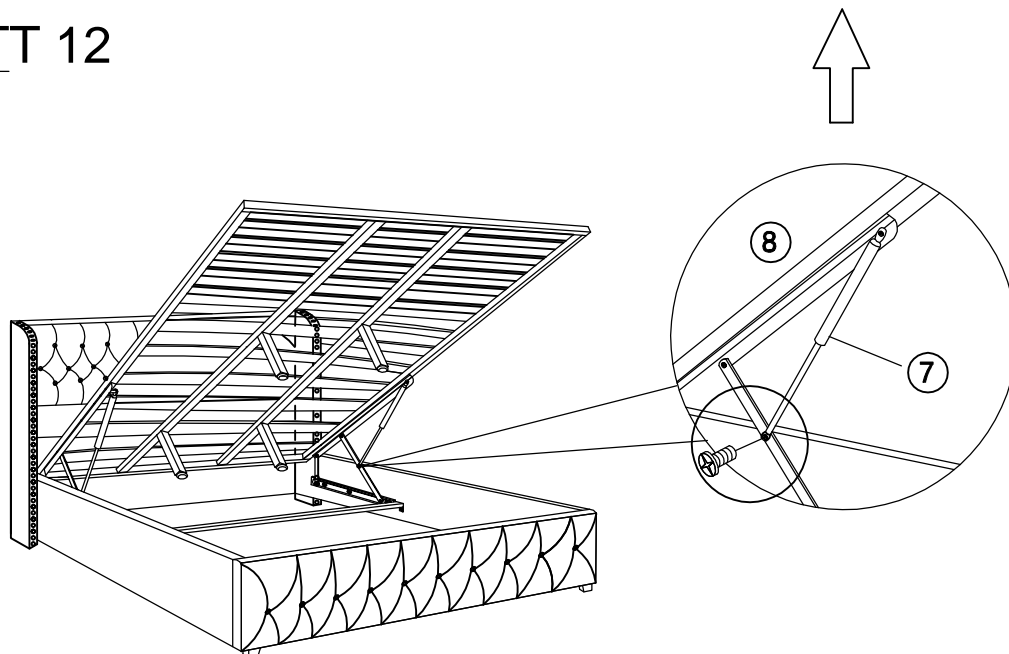

SCHRAUBEN SIE DIESE SCHRAUBE (1 STÜCK) VON TEIL H AB;  
HEBEN SIE DANN DIE BASIS AUF DIE MAXIMALE HÖHE AN.  
SCHRAUBEN SIE DEN BOLZEN FEST AN ;

# SCHRITT 13

13  1PC

