

# Computer Desk

Item No. FD4-4824-EU/FD4-5524-EU/FD4-6324-EU

User Manual

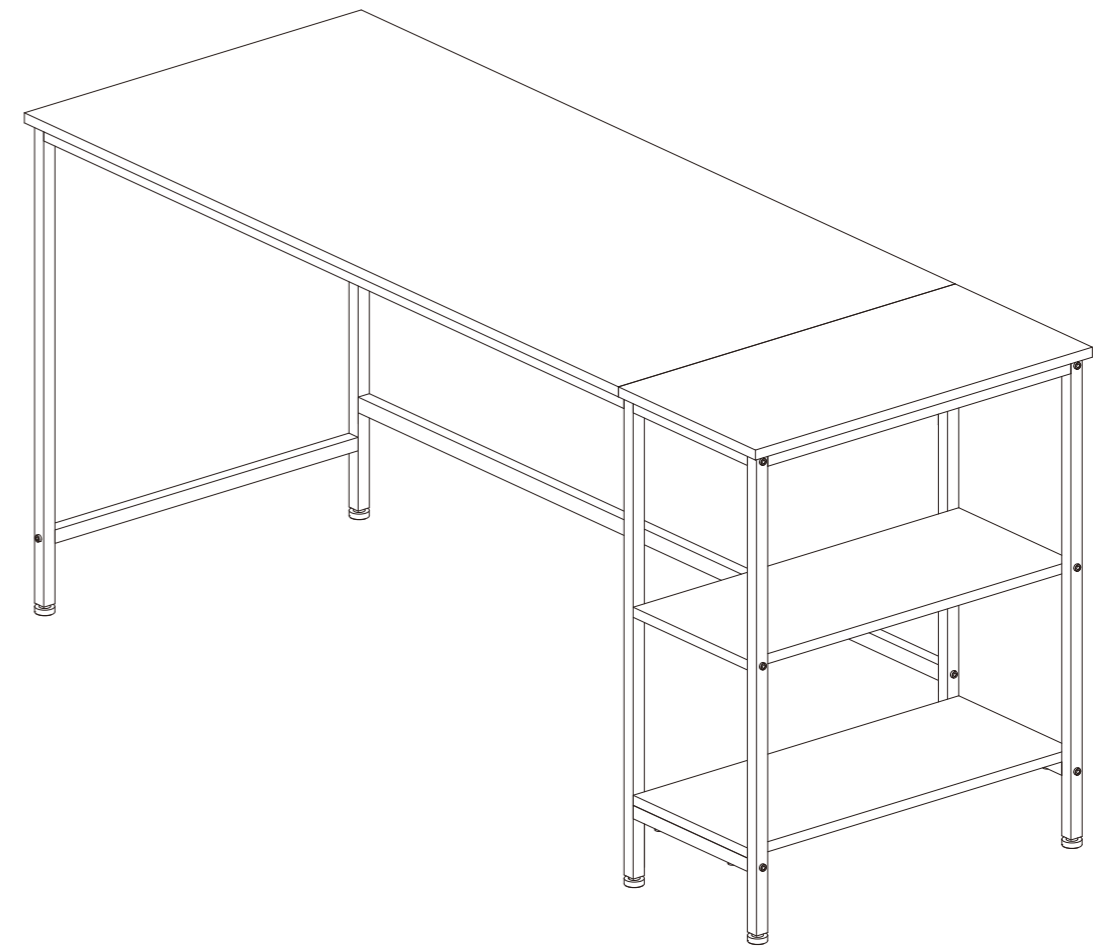

# CONTENTS

English-----01

German-----07

French-----13

Italian-----19

Spanish-----25



## Parts List

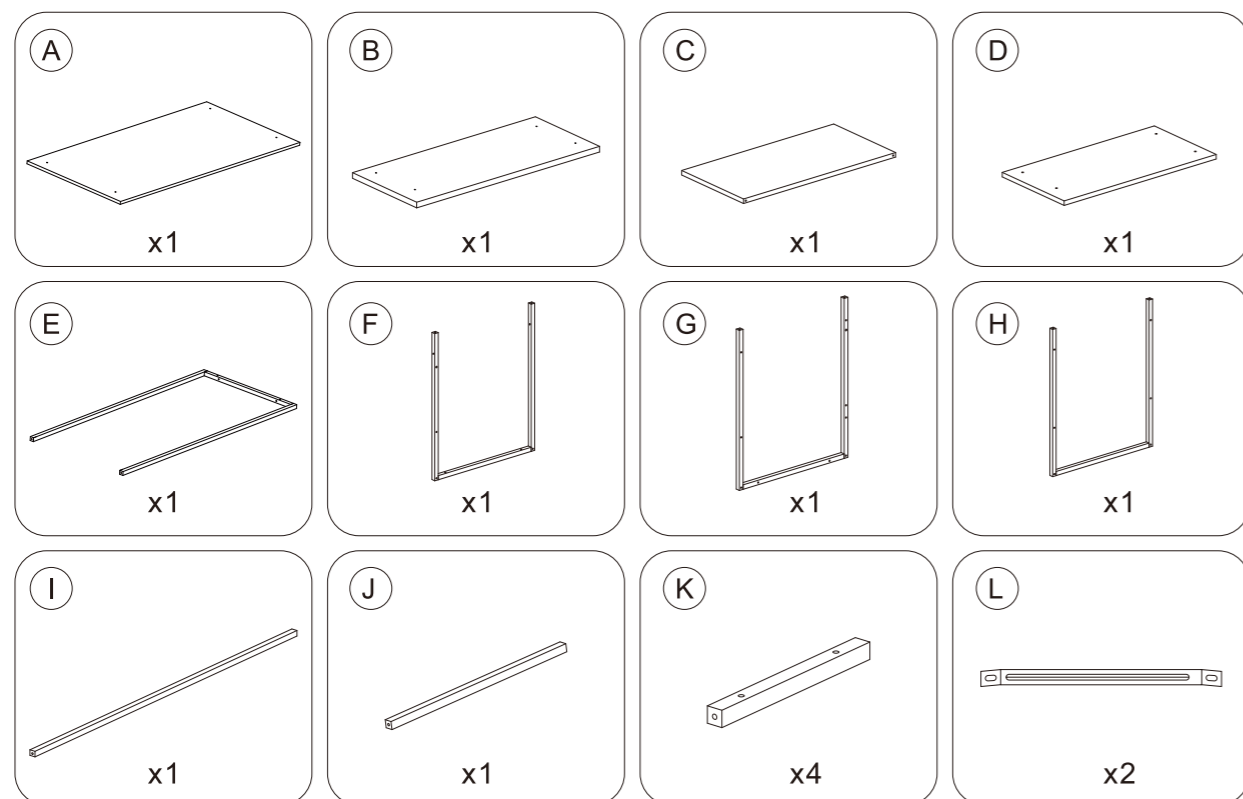

## Attention



1. Before you begin: Lay out all parts on a clean surface to check if the tags and numbers are correct.
2. Don't screw tightly before all the screws are put into the corresponding holes.
3. Please use the screws correctly, otherwise you might damage the desktop.
4. It is recommended to install this desk by two people.

### NOTES:

1. Keep away from humidity and the sunlight.
2. Don't push/pull it hardly, that will make the steel legs and the screws loose and broken.
3. Daily maintenance: Wipe the surface with a dry, clean, soft dishrag.
4. The corners of the iron parts are sharp, please pay attention when installing.
5. This product contains small parts that may cause suffocation if swallowed by children.
6. There is a gap in the process of splicing the product parts, beware of pinching.
7. Please make sure that the child does not climb and cause a dumping injury.

# 1

- a** Please note that the padding iron pieces should be facing outwards.

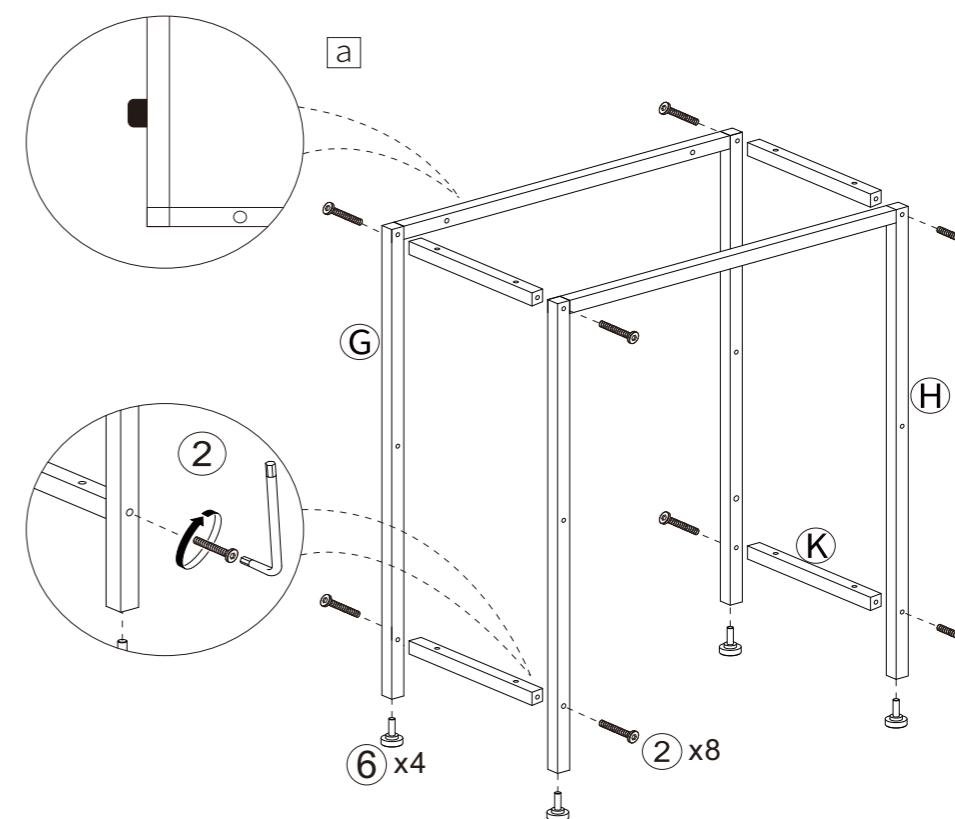
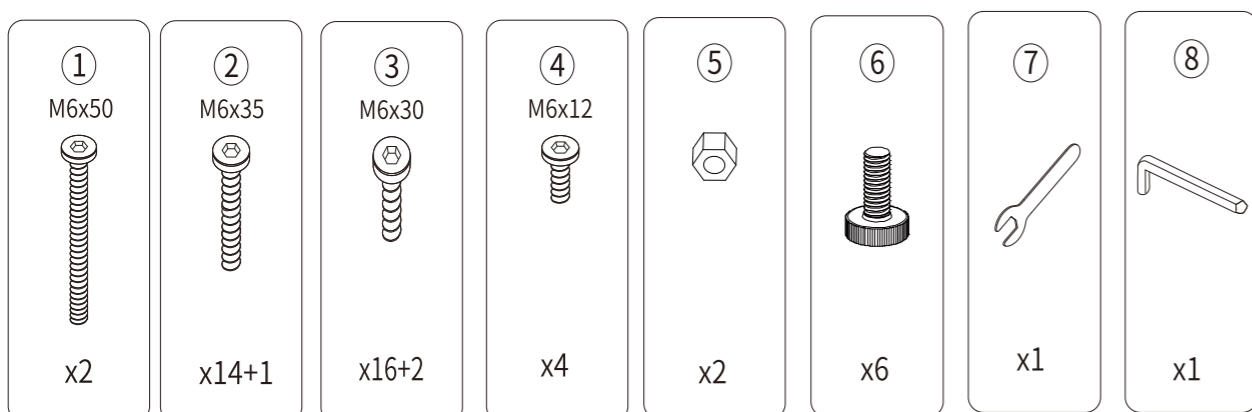

2

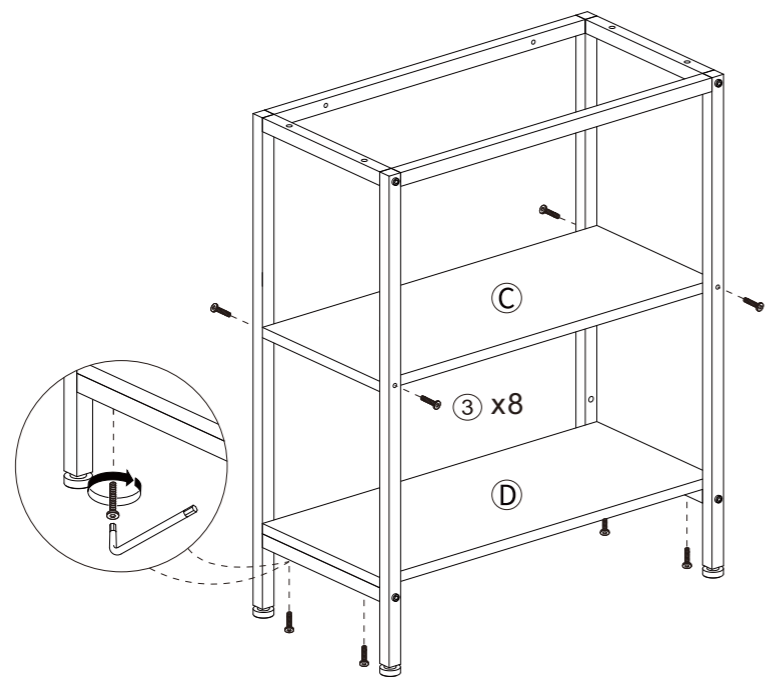

4

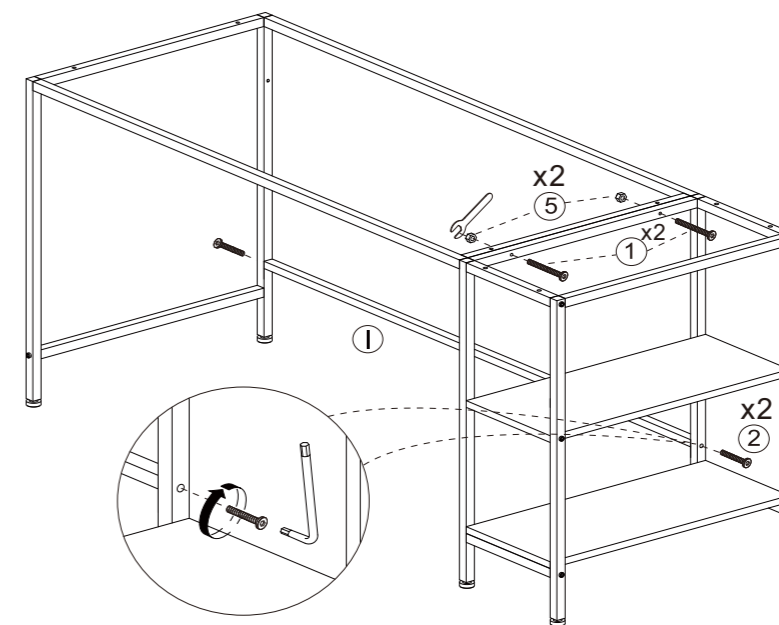

3

b Please note: Two protruding screw holes should be on the same side to install the strut connecting components F and E.

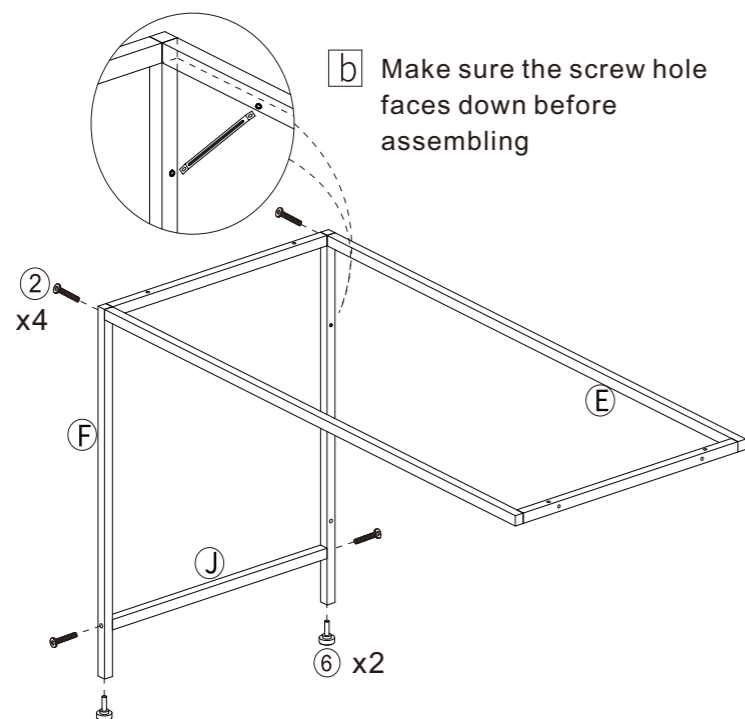

5

c If the holes of the desk frame and desk board don't match, please change the direction of the board and try again.  
 d The desktop can only be fixed with screws 2. DO NOT screw tightly in this step.

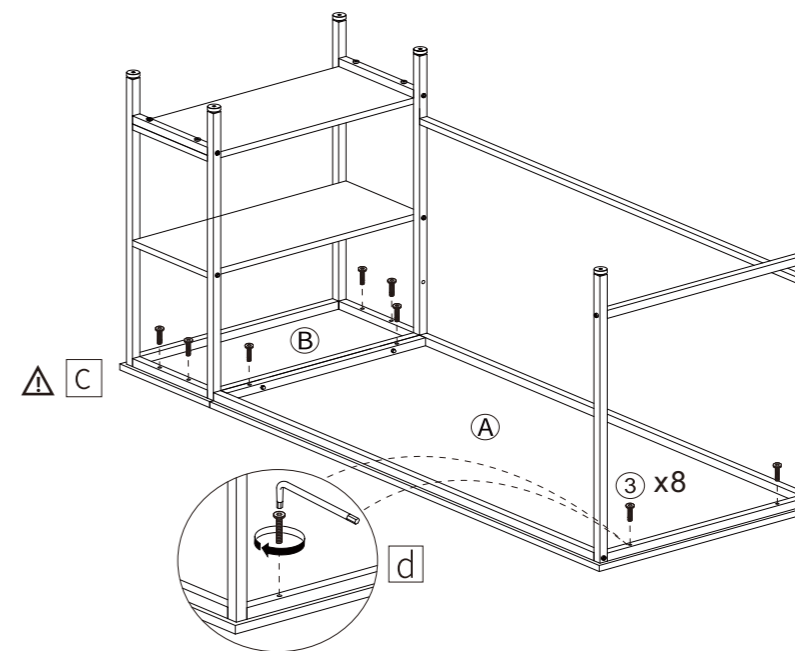

6

e Tighten all the screws when there is no gap between the two boards.

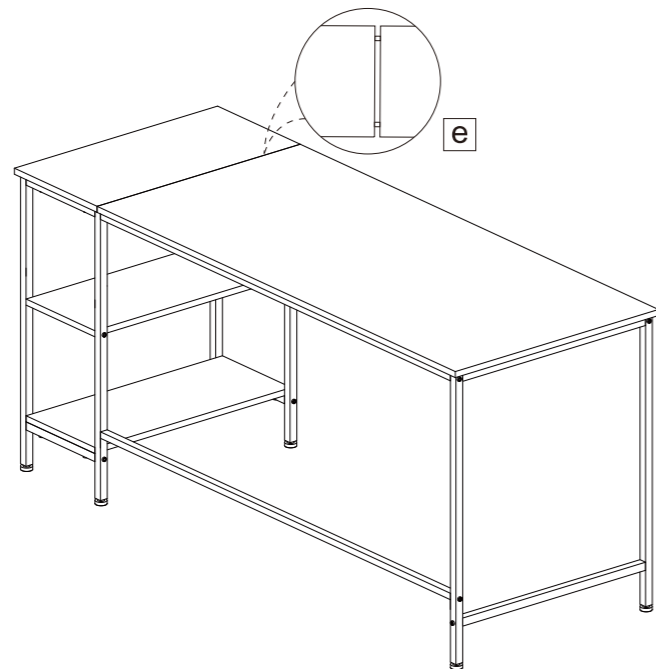

8

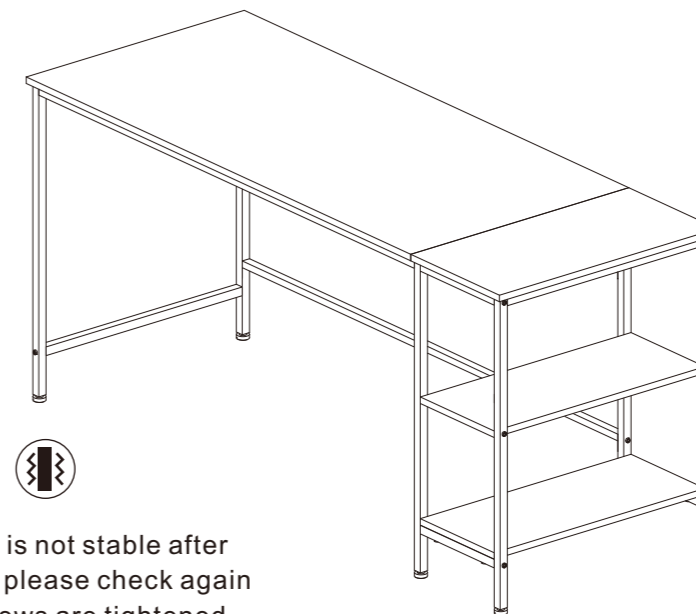

7

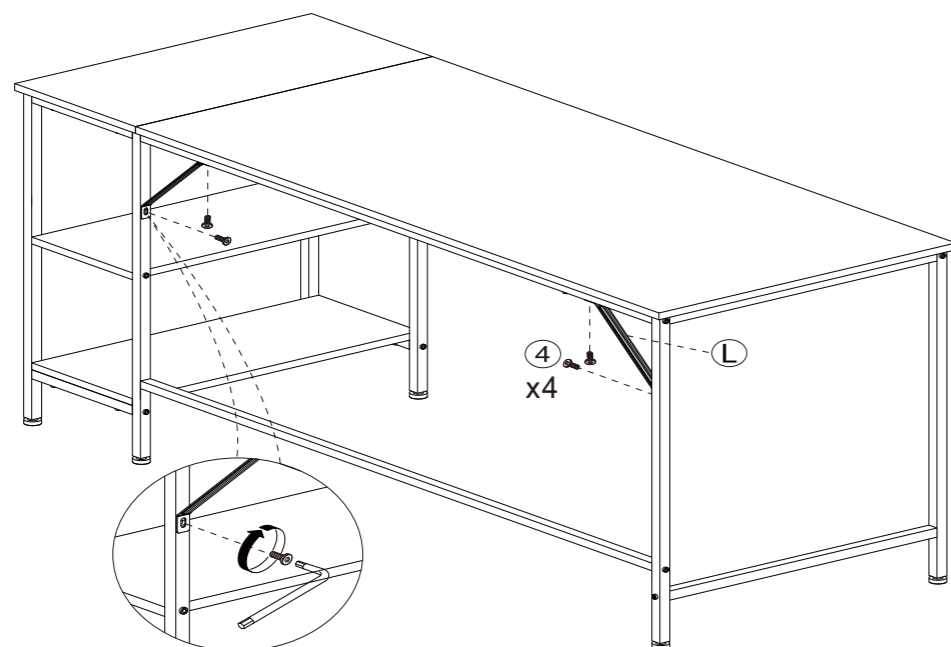

Put the two screws into the screw holes at the same time, and then tighten the screw.

9 Recycling and Disposal



This product cannot be disposed of as household waste. To prevent damage to the environment, this product should be recycled. Please use the relevant recycling systems available to you or contract the distributor or manufacturer for recycling assistance.



## Teileliste

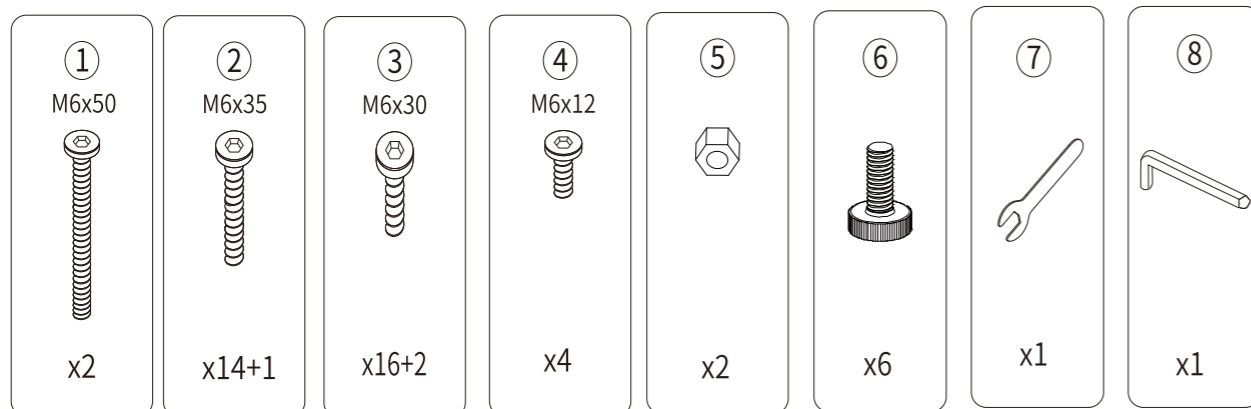
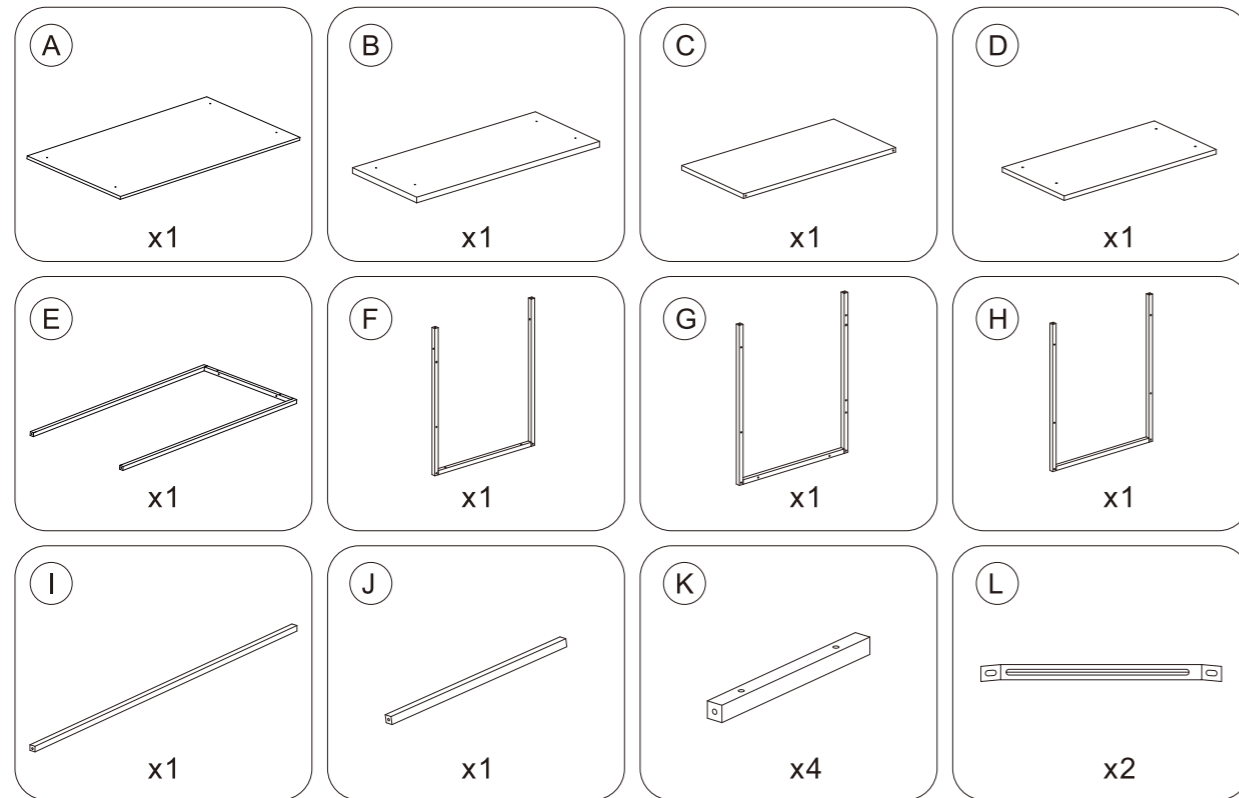

## Wichtig



1. Bevor Sie beginnen: Legen Sie alle Teile auf einer sauberen Unterlage aus, um zu prüfen, ob die Kennzeichnungen und Nummern korrekt sind.
2. Schrauben Sie nicht fest, bevor alle Schrauben in die entsprechenden Löcher eingedreht sind.
3. Bitte verwenden Sie die Schrauben richtig, da Sie sonst die Tischplatte beschädigen könnten.
4. Es wird empfohlen, den Schreibtisch von zwei Personen montieren zu lassen.

### ANMERKUNGEN:

1. Von Feuchtigkeit und Sonnenlicht fernhalten.
2. Drücken/ziehen Sie nicht zu stark daran, da sonst die Stahlbeine und Schrauben locker werden und kaputt gehen.
3. Tägliche Wartung: Wischen Sie die Oberfläche mit einem trockenen, sauberen und weichen Spüllappen ab.
4. Die Ecken der Eisenteile sind scharf, bitte achten Sie bei der Installation darauf.
5. Dieses Produkt enthält Kleinteile, die beim Verschlucken durch Kinder zum Erstickten führen können.
6. Beim Zusammenfügen der Produktteile gibt es eine Lücke. Achten Sie auf Quetschungen.
7. Bitte achten Sie darauf, dass das Kind nicht klettert und sich dadurch verletzt.

## 1

- a Bitte beachten Sie, dass die Polstereisen nach außen gerichtet sein müssen.

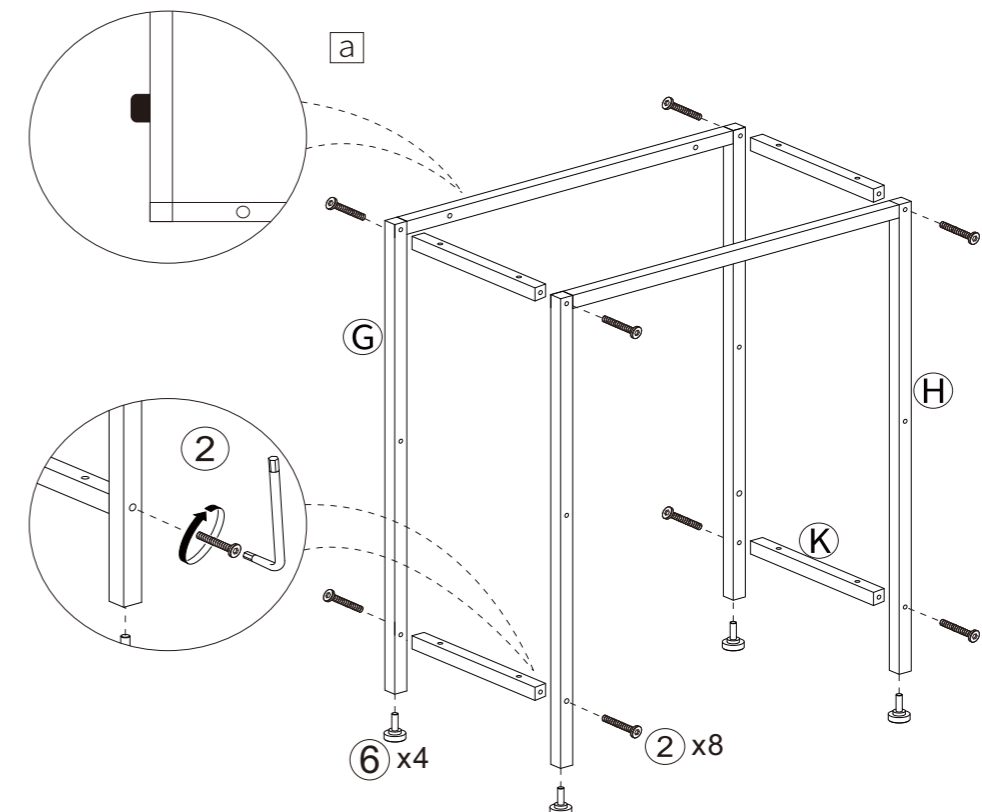

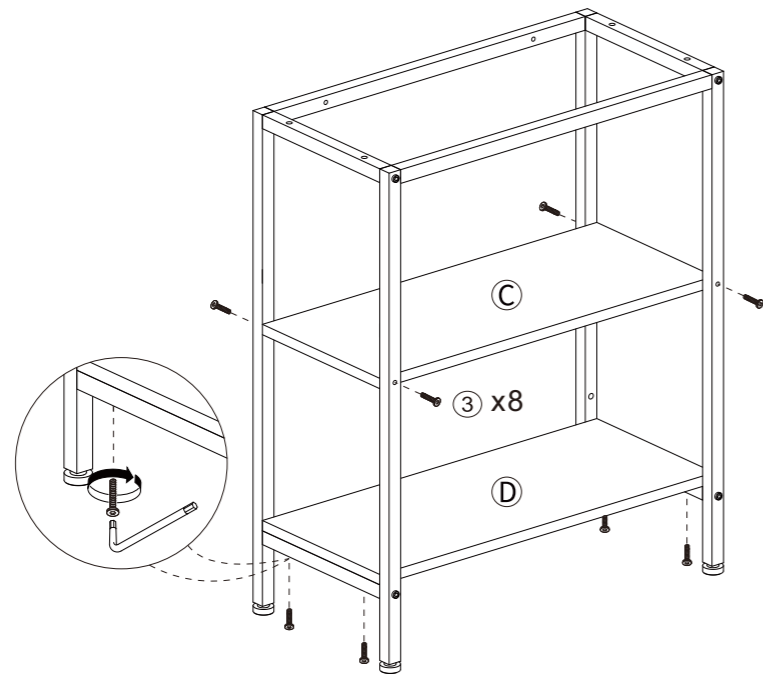
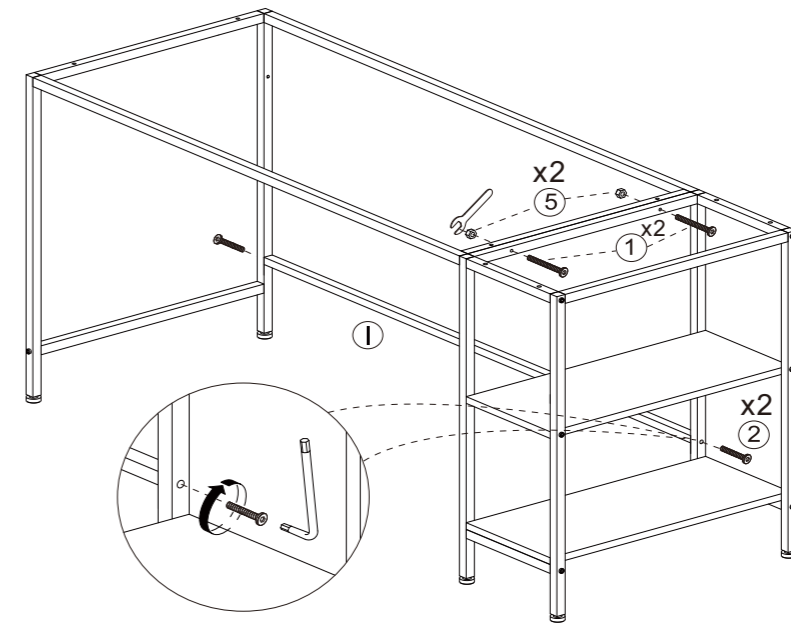
**2****4****3**

- b** Bitte beachten Sie: Zur Montage der Strebenverbindungsteile F und E sollten sich zwei hervorstehende Schraubenlöcher auf der gleichen Seite befinden

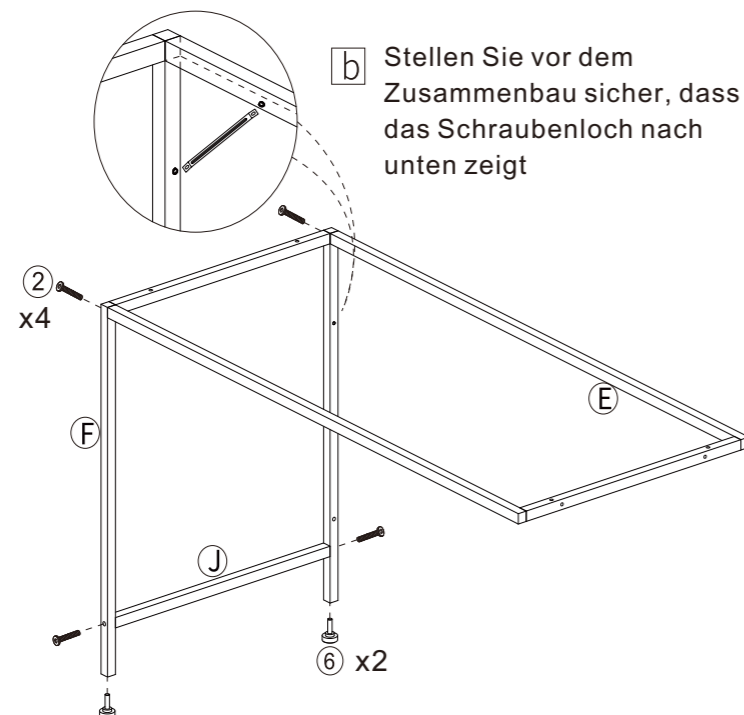
**5**

- c** Wenn die Löcher des Schreibtischrahmens und der Schreibtischplatte nicht übereinstimmen, ändern Sie bitte die Ausrichtung der Platte und versuchen Sie es erneut.
- d** Die Tischplatte kann nur mit Schrauben ② befestigt werden. In diesem Schritt NICHT festschrauben.

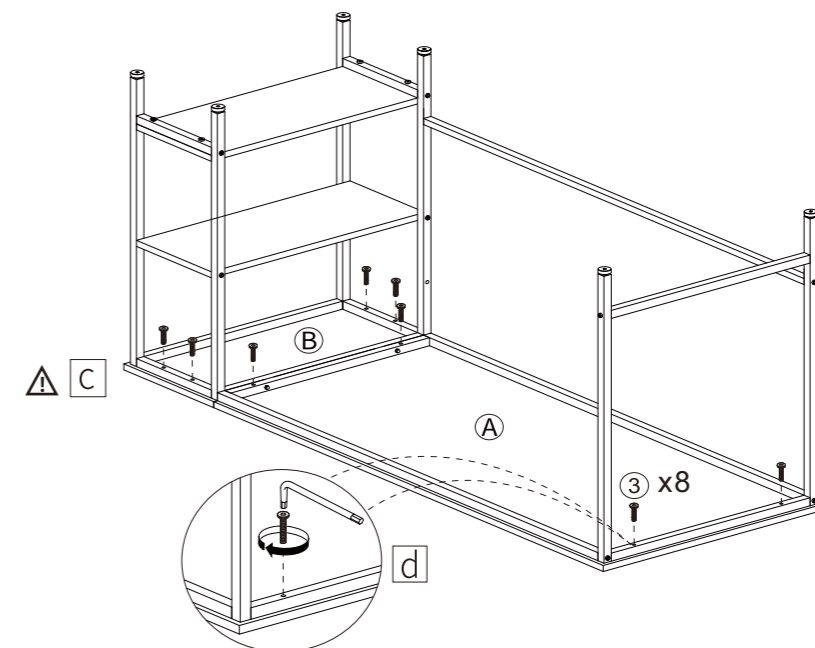

**6**

**e** Ziehen Sie alle Schrauben fest, wenn zwischen den beiden Brettern kein Spalt mehr vorhanden ist.

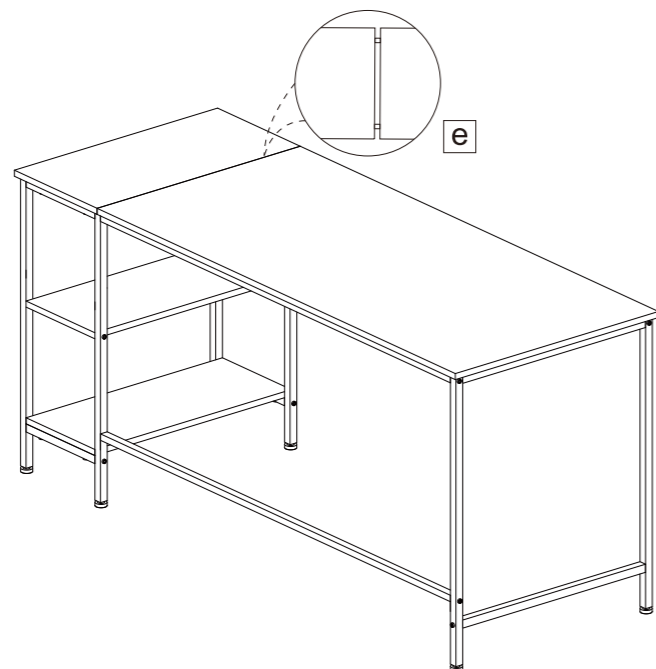
**8**

Sollte der Tisch nach der Montage nicht stabil sein, überprüfen Sie bitte nochmals, ob alle Schrauben fest angezogen sind.

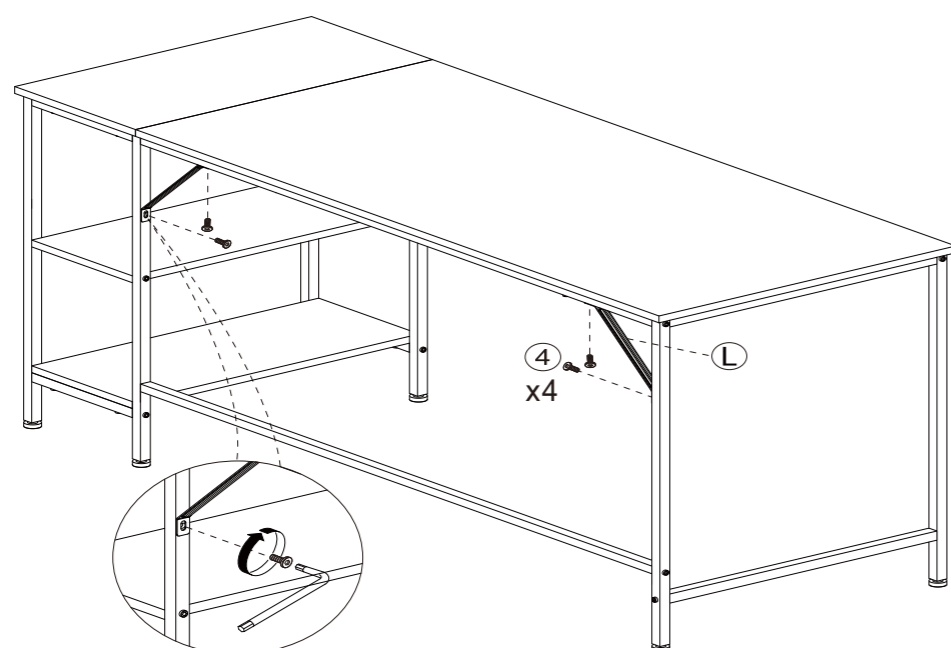
**7**

Setzen Sie die beiden Schrauben gleichzeitig in die Schraubenlöcher ein und ziehen Sie dann die Schraube fest.

**9**

## Recycling und Entsorgung



Dieses Produkt kann nicht als Hausmüll entsorgt werden. Dieses Produkt sollte recycelt werden, um Umweltschäden zu vermeiden. Verwenden Sie bitte die entsprechenden Recycling-Systeme, die Ihnen zur Verfügung stehen, oder vereinbaren Sie mit dem Händler oder Hersteller Hilfe beim Recycling.





## Parts List

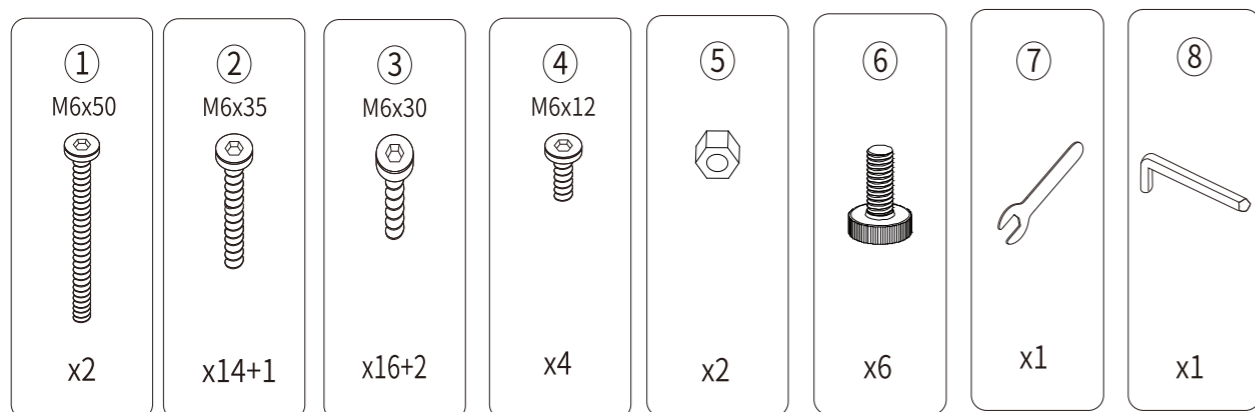
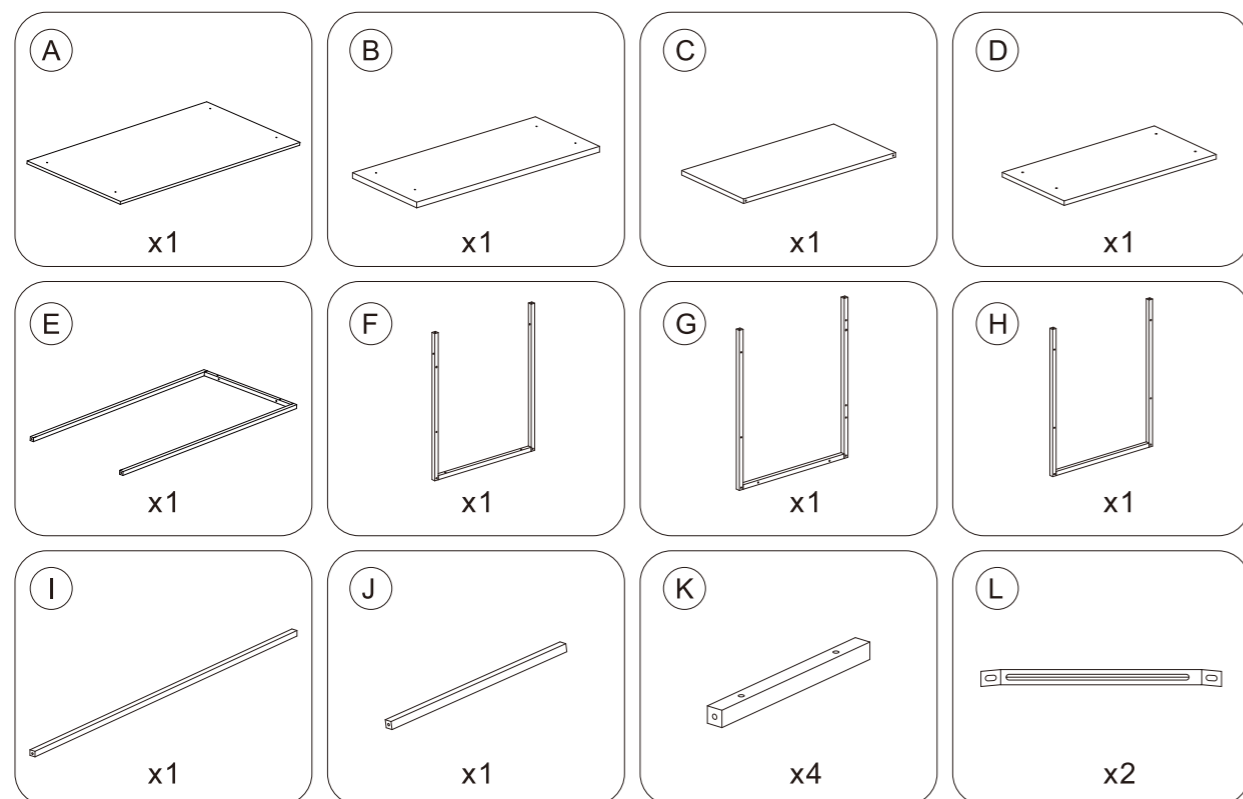

## Attention



1. Avant de commencer : Disposez toutes les pièces sur une surface propre pour vérifier si les étiquettes et les numéros sont corrects.
2. Ne vissez pas fermement avant que toutes les vis ne soient placées dans les trous correspondants.
3. Veuillez utiliser les vis correctement, sinon vous risquez d'endommager le panneau du bureau
4. Il est recommandé d'installer ce bureau par deux personnes.

### REMARQUES:

1. Tenir à l'écart de l'humidité et de la lumière du soleil.
2. Ne le poussez pas/le tirez à peine, cela rendra les pieds en acier et les vis desserrés et cassés.
3. Entretien quotidien : essuyez la surface avec un chiffon sec, propre et doux.
4. Les coins des pièces en fer sont tranchants, veuillez faire attention lors de l'installation.
5. Ce produit contient de petites pièces qui peuvent provoquer une suffocation si elles sont avalées par des enfants.
6. Il y a un écart dans le processus d'épissage des pièces du produit, méfiez-vous des pincements.
7. Veuillez vous assurer que l'enfant ne grimpe pas et ne cause pas de blessure par dumping.

## 1

- a) Veuillez noter que les pièces de rembourrage en fer doivent être tournées vers l'extérieur.

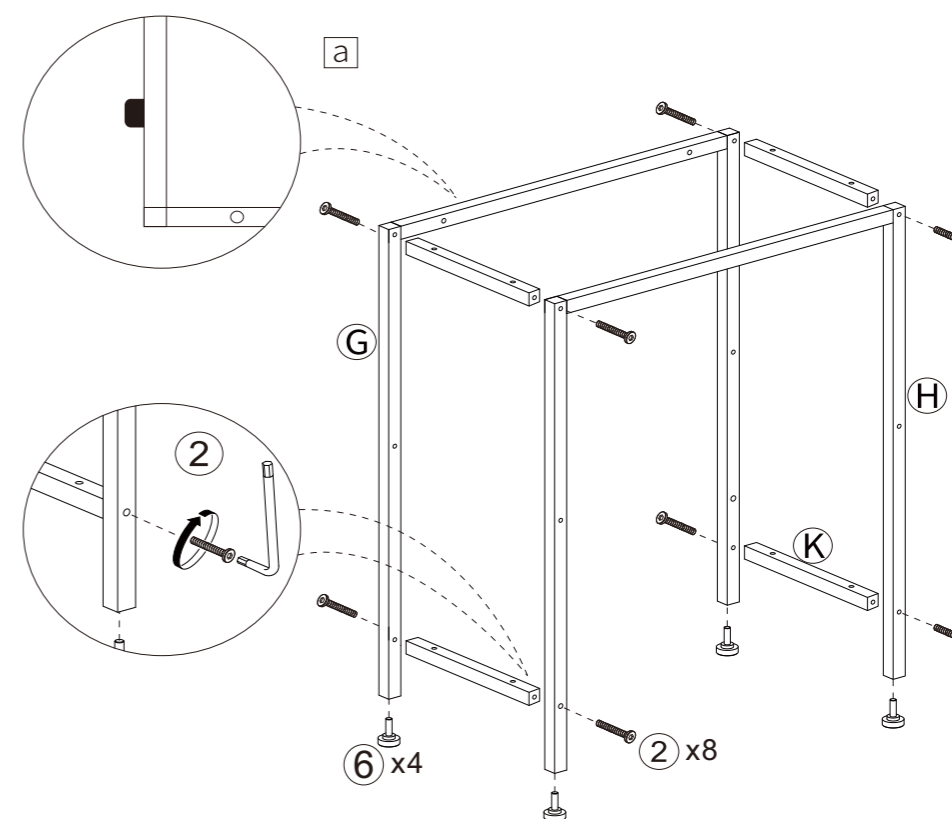

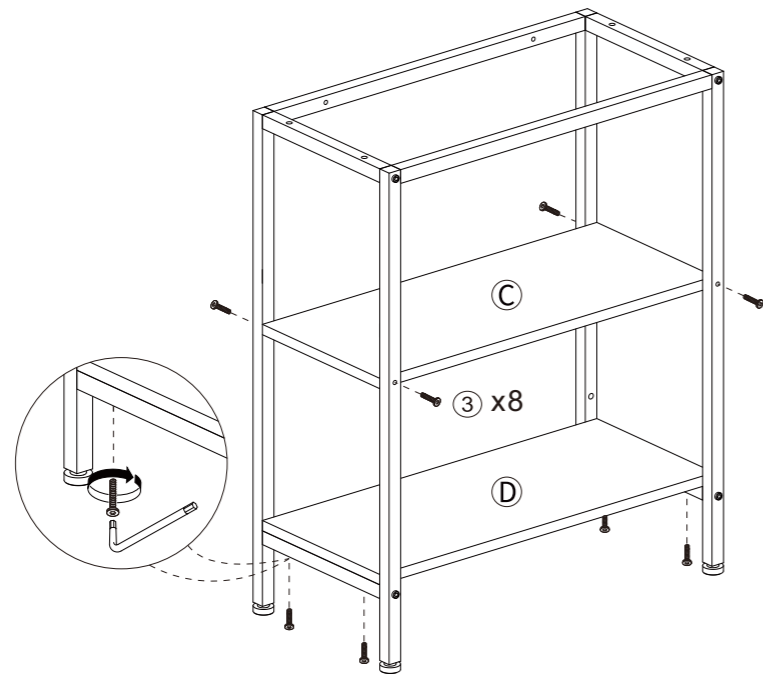
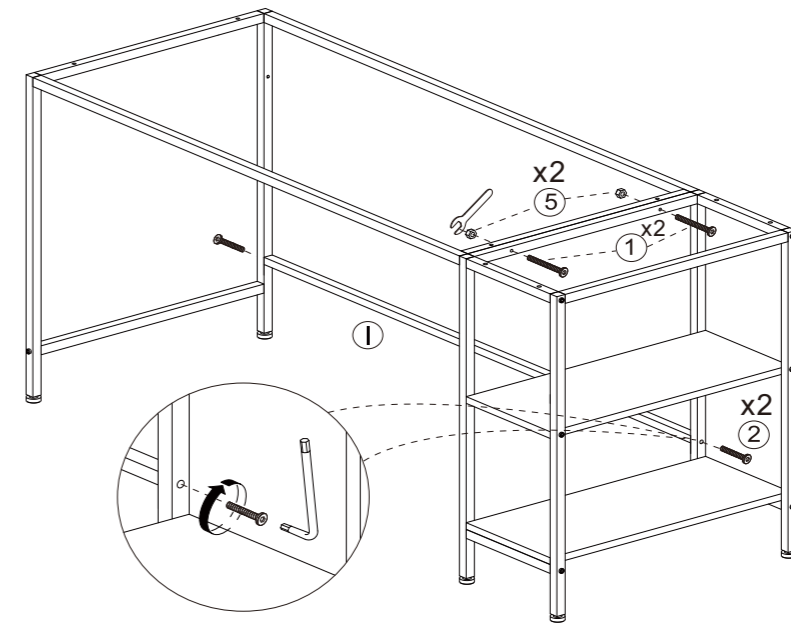
**2****4****3**

b) Veuillez noter : Deux trous de vis saillants doivent être du même côté pour installer les composants de connexion de la jambe de force F et E.

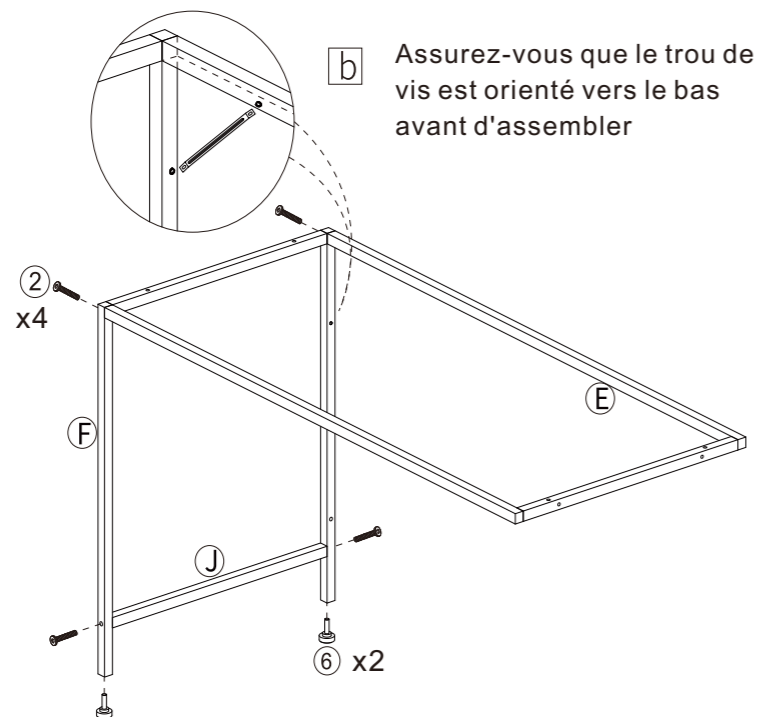
**5**

c) Si les trous du cadre du bureau et du plateau du bureau ne correspondent pas, veuillez changer la direction du plateau et réessayer.  
 d) Le bureau ne peut être fixé qu'avec des vis 2. NE PAS visser fermement à cette étape

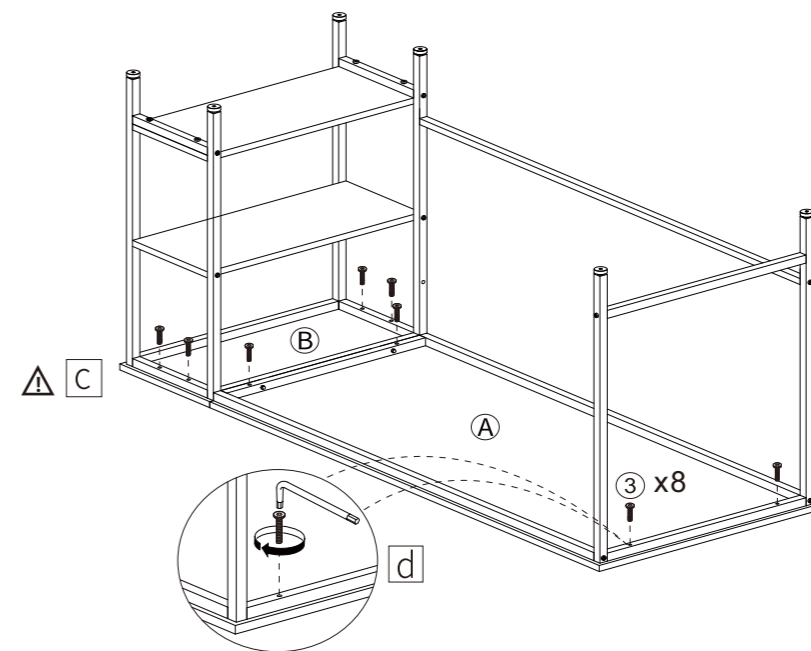

**6**

 Serrez toutes les vis lorsqu'il n'y a pas d'espace entre les deux planches.

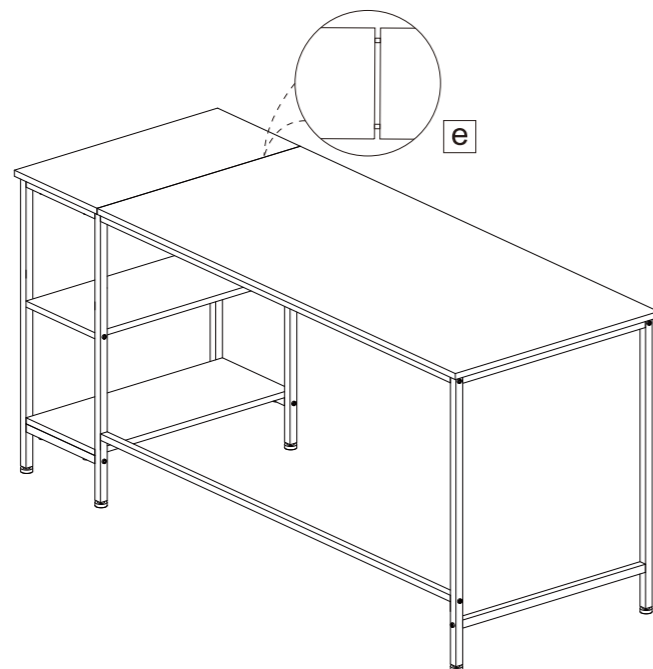
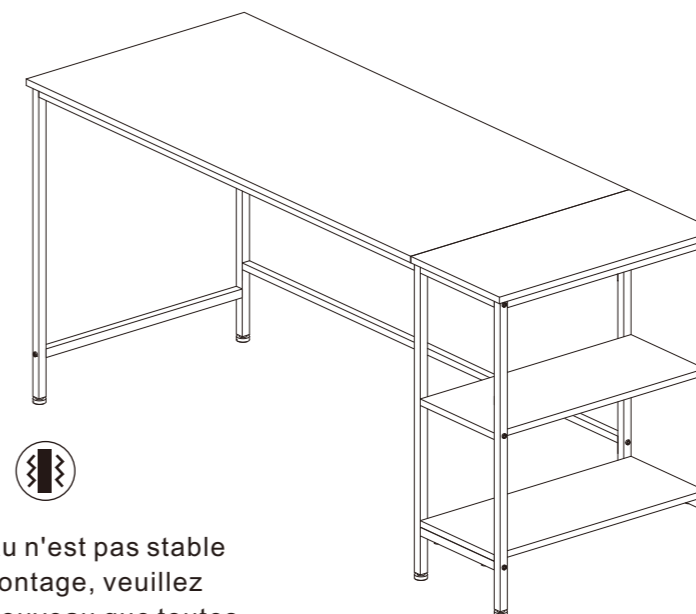
**8**

Si le bureau n'est pas stable après le montage, veuillez vérifier à nouveau que toutes les vis sont bien serrées.

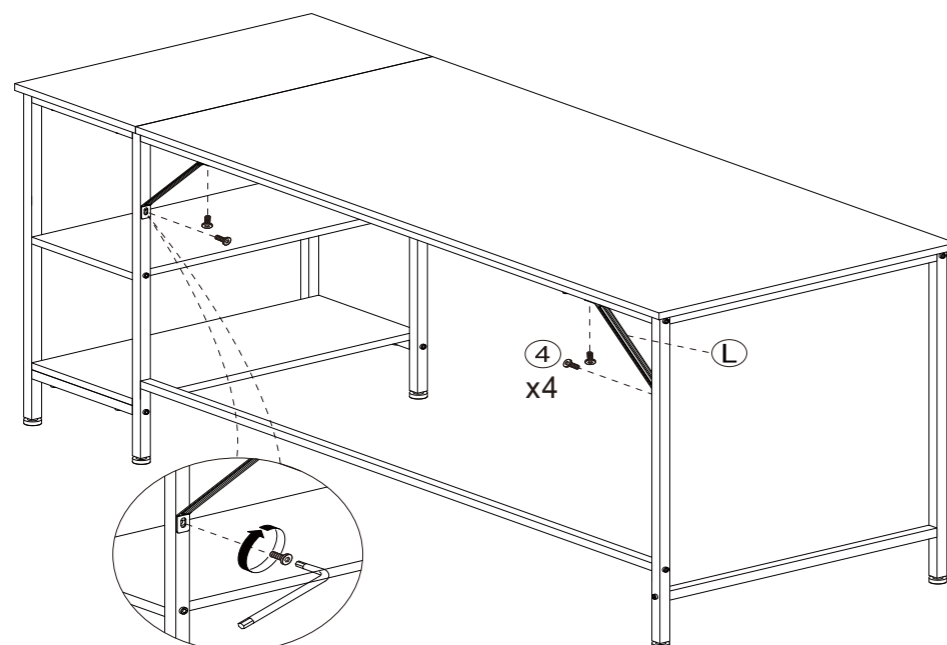
**7**

Mettez les deux vis dans les trous de vis en même temps, puis les serrez.

**9**

### Recyclage et Élimination



Ce produit ne peut être éliminé comme déchet domestique. Pour éviter d'endommager l'environnement, ce produit devrait être recyclé. Utilisez le système relatif de recyclage disponible ou contactez le distributeur ou le fabricant pour l'assistance de recyclage, s'il vous plaît.



## Elenco delle parti

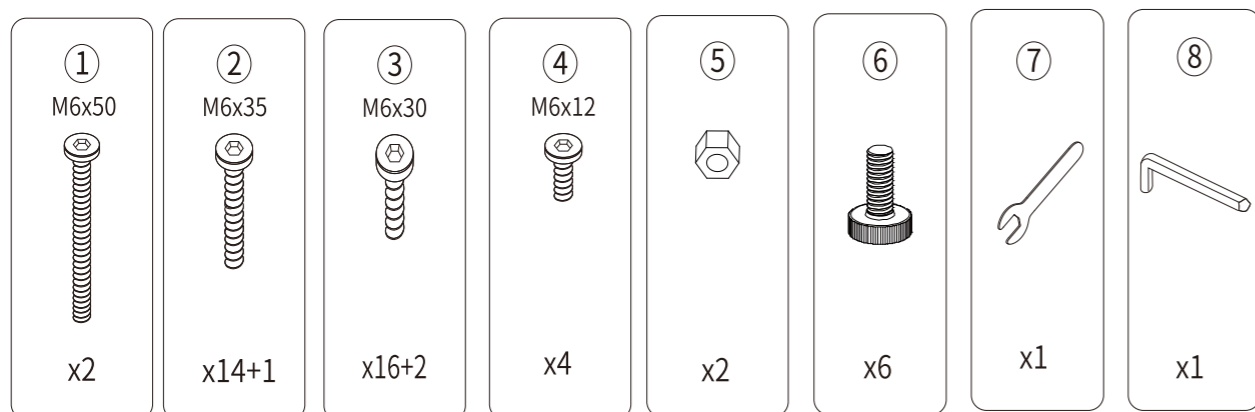
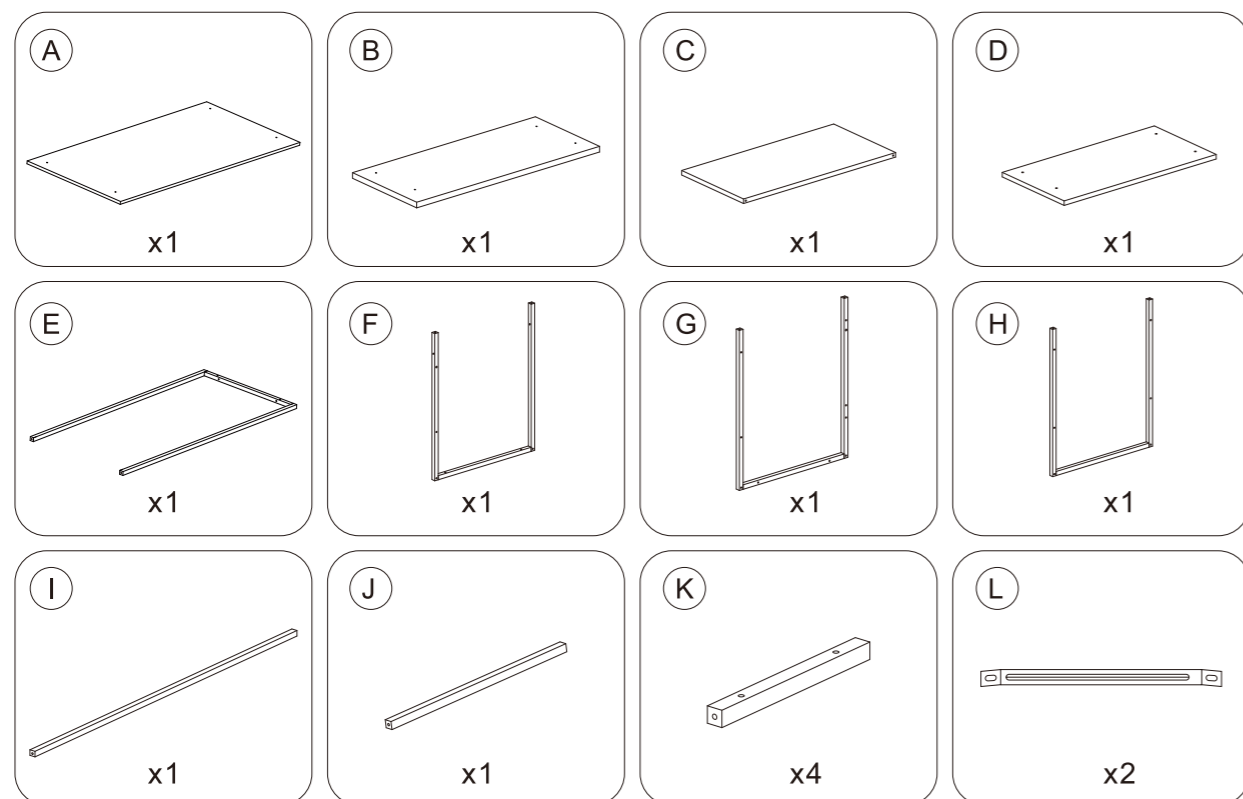

## Importante



1. Prima di iniziare: Appoggia tutte le parti su una superficie pulita per controllare se le etichette e i numeri sono corretti.
2. Non avvitare con forza prima di posizionare tutte le viti nei fori corrispondenti.
3. Utilizzare correttamente le viti, altrimenti si potrebbe danneggiare il pannello del desktop.
4. Si consiglia che due persone installino questa scrivania.

### GRADI:

1. Tenere lontano dall'umidità e dalla luce solare.
2. Non spingere o tirare con forza, ciò potrebbe causare l'allentamento e la rottura dei piedini e delle viti in acciaio.
3. Manutenzione quotidiana: pulire la superficie con un panno asciutto, pulito e morbido.
4. Gli angoli delle parti in ferro sono affilati, prestare attenzione durante l'installazione.
5. Questo prodotto contiene piccole parti che possono causare soffocamento se ingerite dai bambini.
6. C'è una lacuna nel processo di giunzione delle parti del prodotto, fare attenzione al pizzicamento.
7. Assicurarsi che il bambino non si arrampichi e non causi lesioni da shock.

## 1

- a** Si noti che i pezzi di ferro devono essere rivolti verso l'esterno.

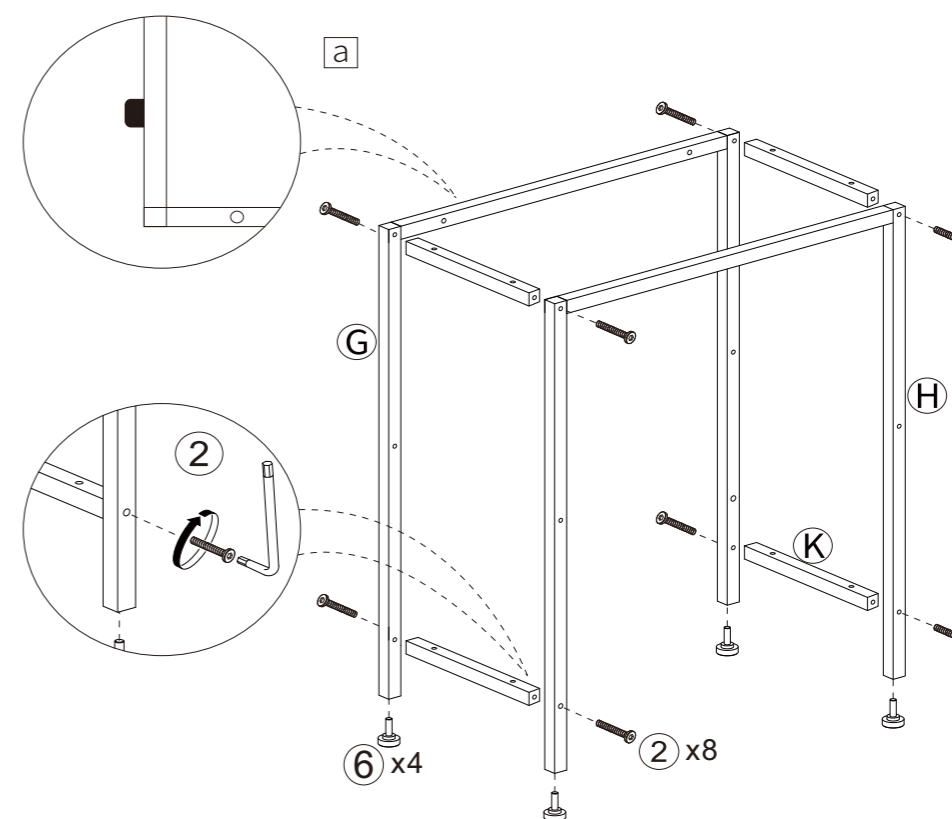

2

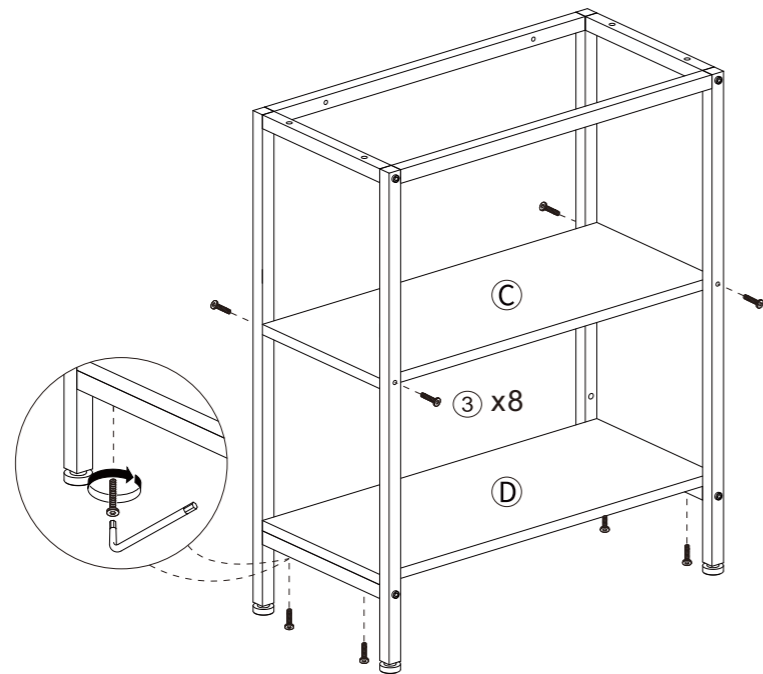

4

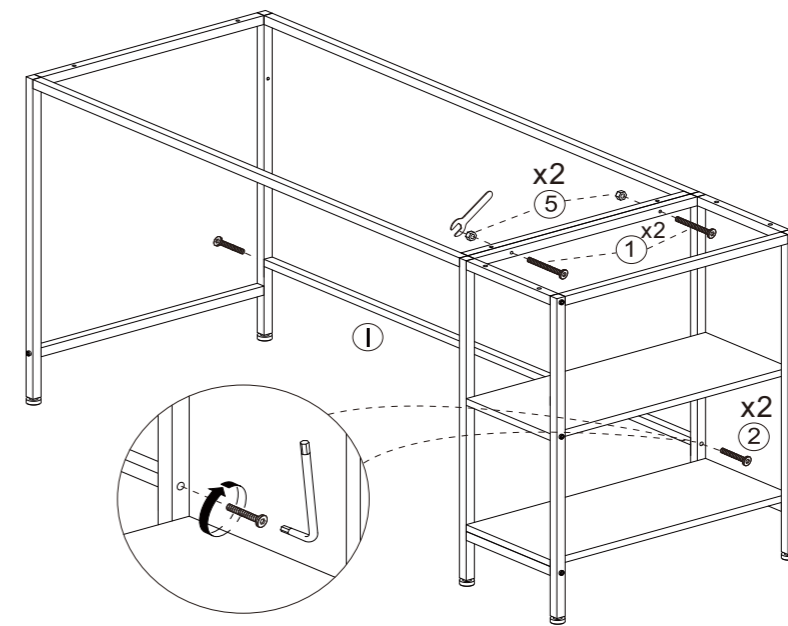

3

b Nota: due fori per viti sporgenti devono trovarsi sullo stesso lato per installare i componenti di collegamento del puntone F ed E.

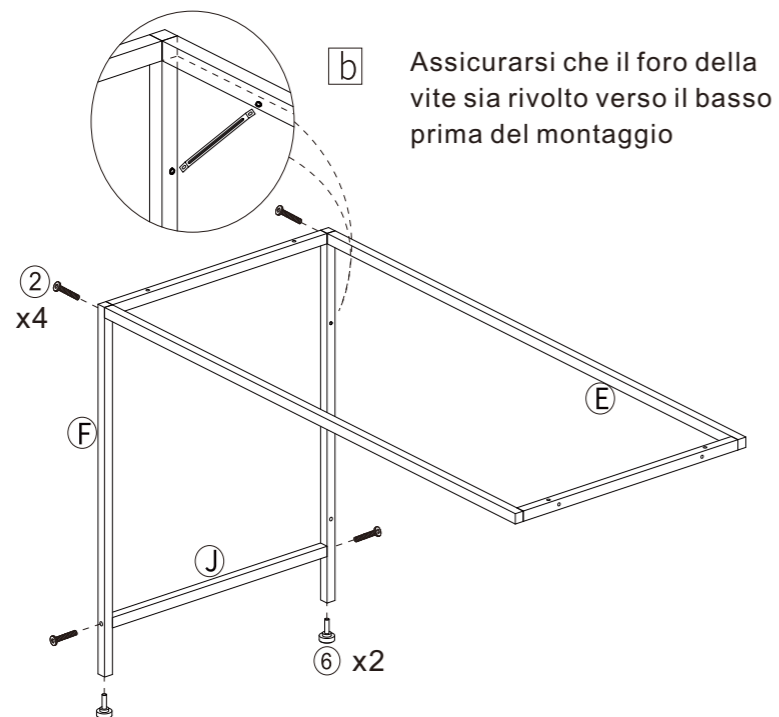

5

c Se i fori del telaio della scrivania e del piano della scrivania non corrispondono, cambiare la direzione del piano e riprovare.  
 d Il desktop può essere fissato solo con viti ②. NON avvitare forte in questo passaggio.

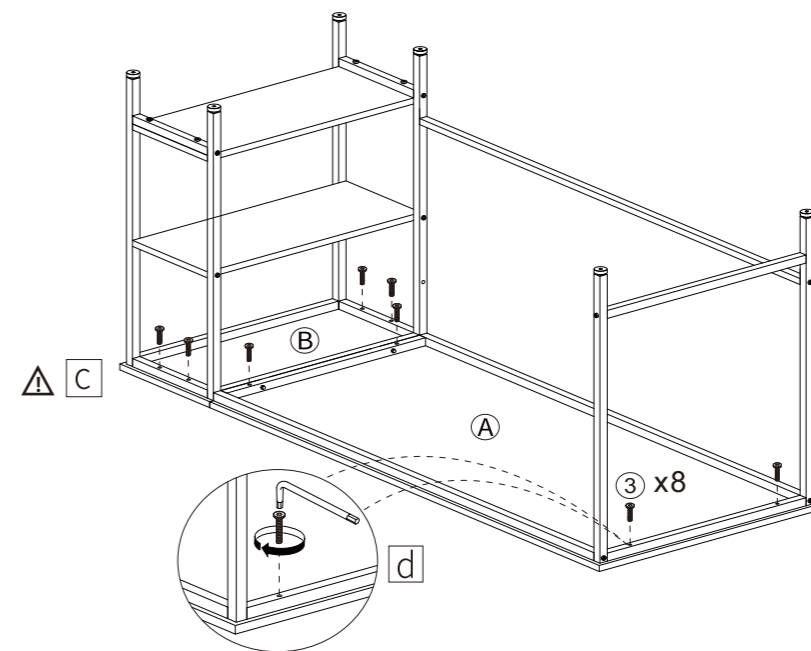

**6**

 Serrare tutte le viti quando non c'è spazio tra le due schede.

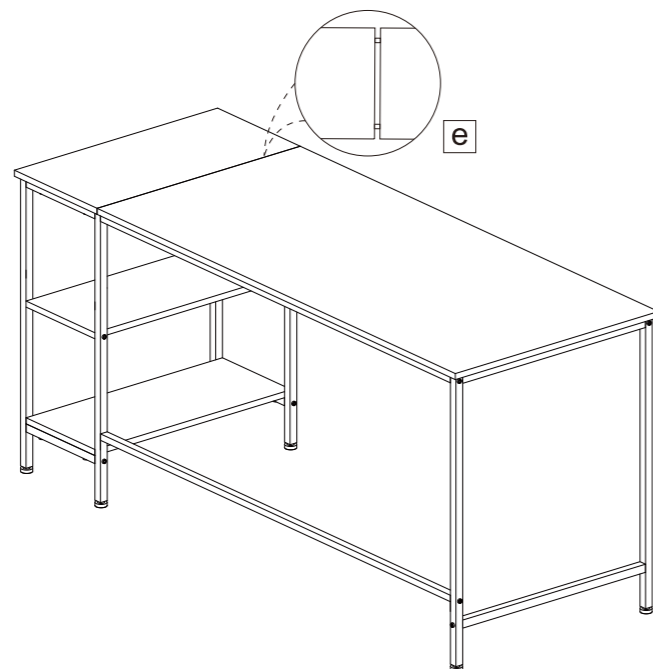
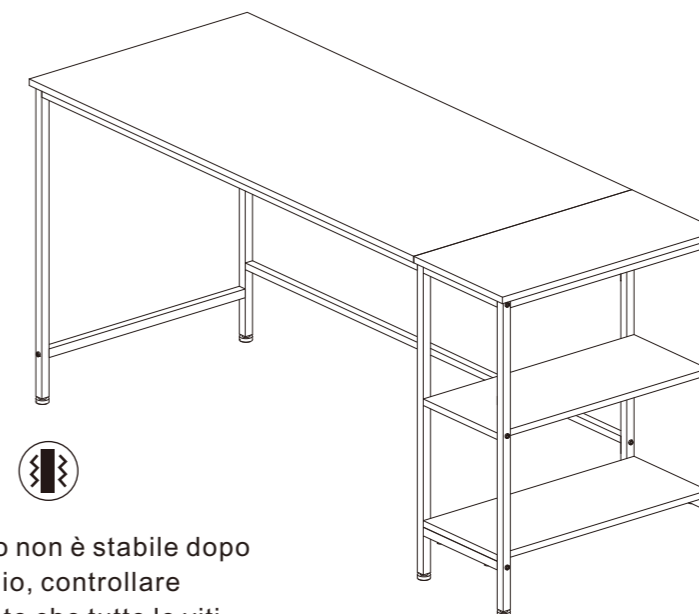
**8**

Se il tavolo non è stabile dopo il montaggio, controllare nuovamente che tutte le viti siano serrate.

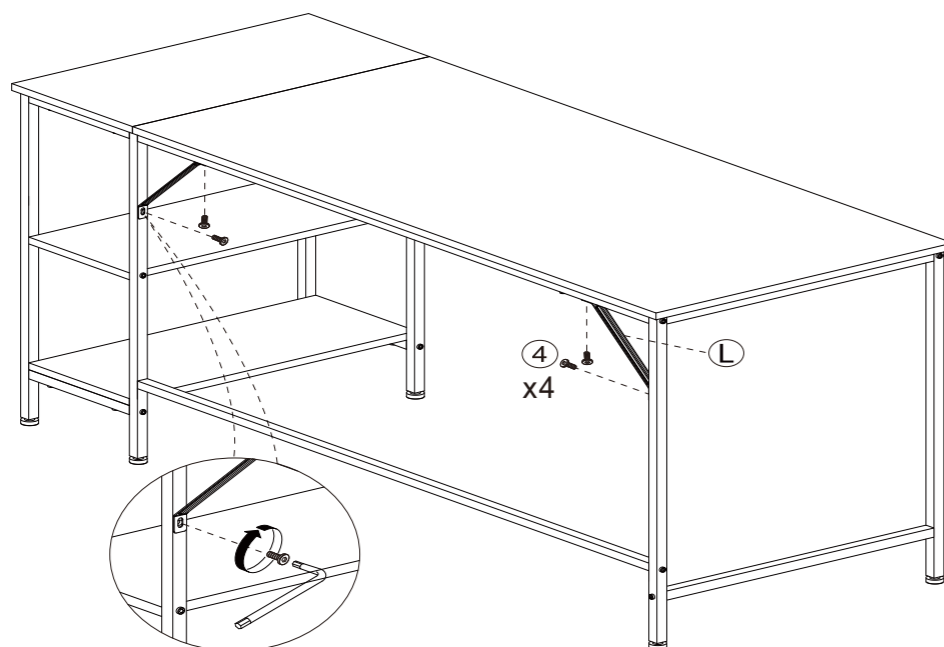
**7**

Inserire contemporaneamente le due viti nei fori delle viti, quindi serrare la vite

**9**

**Riciclaggio e Smaltimento**



Questo prodotto non può essere smaltito come rifiuto domestico. Per evitare danni all'ambiente, questo prodotto deve essere riciclato. Utilizzare i sistemi di riciclaggio pertinenti disponibili o rivolgersi al distributore o al produttore per l'assistenza al riciclaggio.



## Lista de piezas

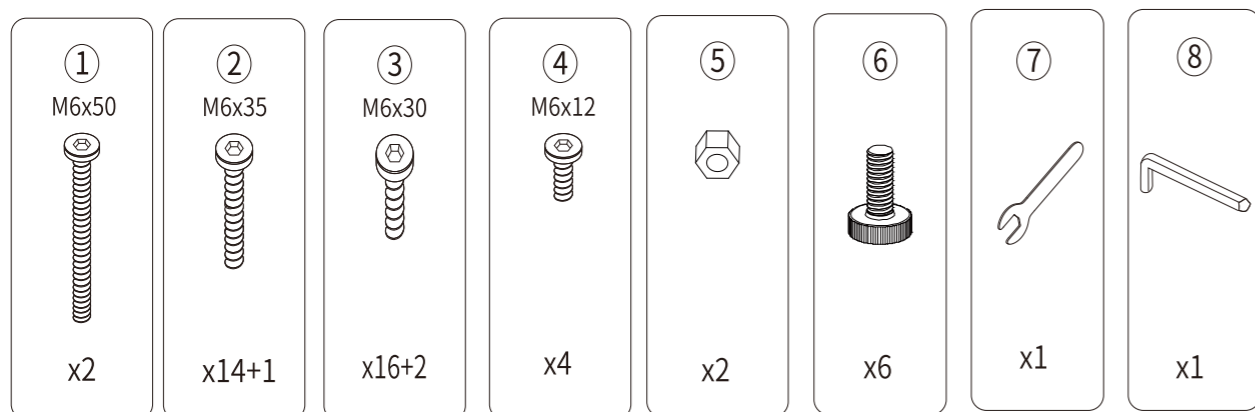
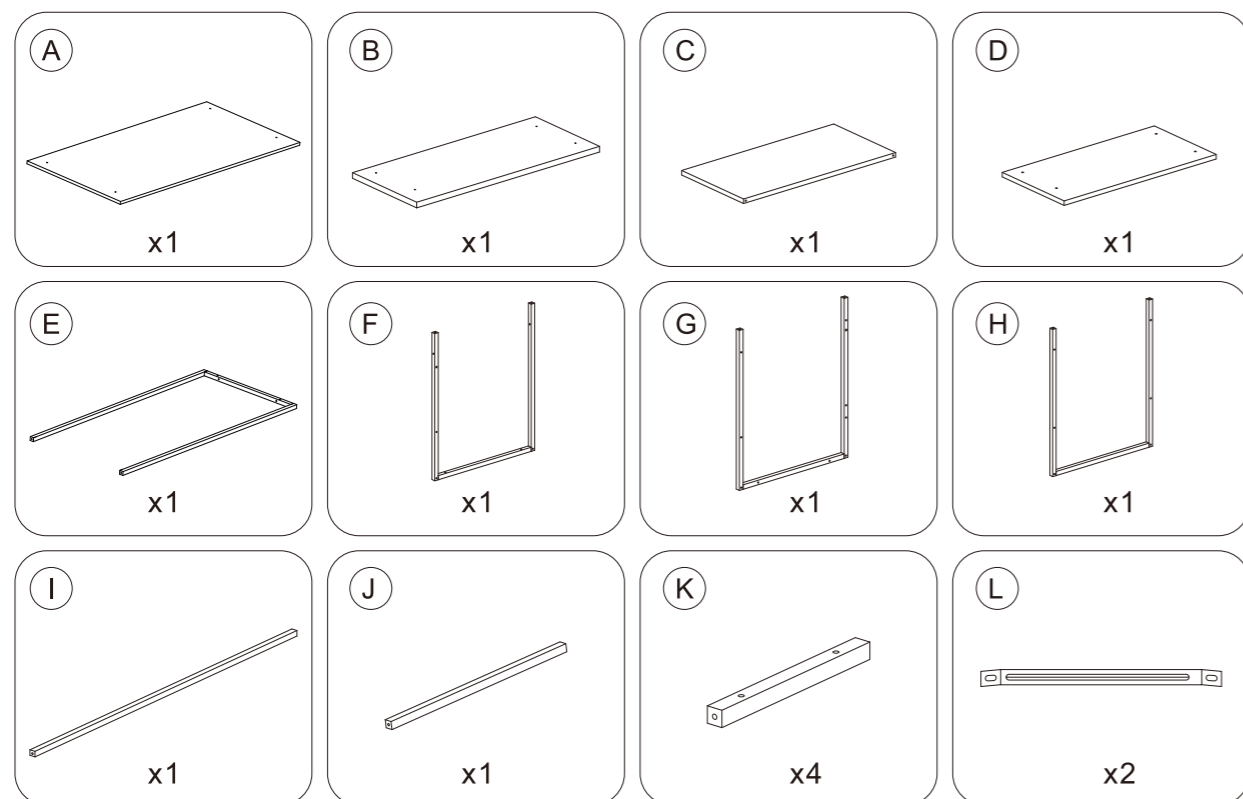

## Importante



1. Antes de comenzar: coloque todas las piezas sobre una superficie limpia para verificar si las etiquetas y los números son correctos.
2. No atornille con fuerza antes de colocar todos los tornillos en los orificios correspondientes.
3. Utilice los tornillos correctamente, de lo contrario podría dañar el panel del escritorio.
4. Se recomienda que dos personas instalen este escritorio.

### NOTAS:

1. Mantener alejado de la humedad y la luz solar.
2. No empuje ni tire con fuerza, eso hará que las patas de acero y los tornillos se suelten y se rompan.
3. Mantenimiento diario: limpie la superficie con un trapo seco, limpio y suave.
4. Las esquinas de las piezas de hierro son afiladas, preste atención al instalarlas.
5. Este producto contiene piezas pequeñas que pueden causar asfixia si los niños las tragan.
6. Hay una brecha en el proceso de empalme de las piezas del producto, tenga cuidado con los pellizcos.
7. Asegúrese de que el niño no suba y cause una lesión por descarga.

## 1

- a Tenga en cuenta que piezas de almohadilla de hierro debe mirar hacia afuera.

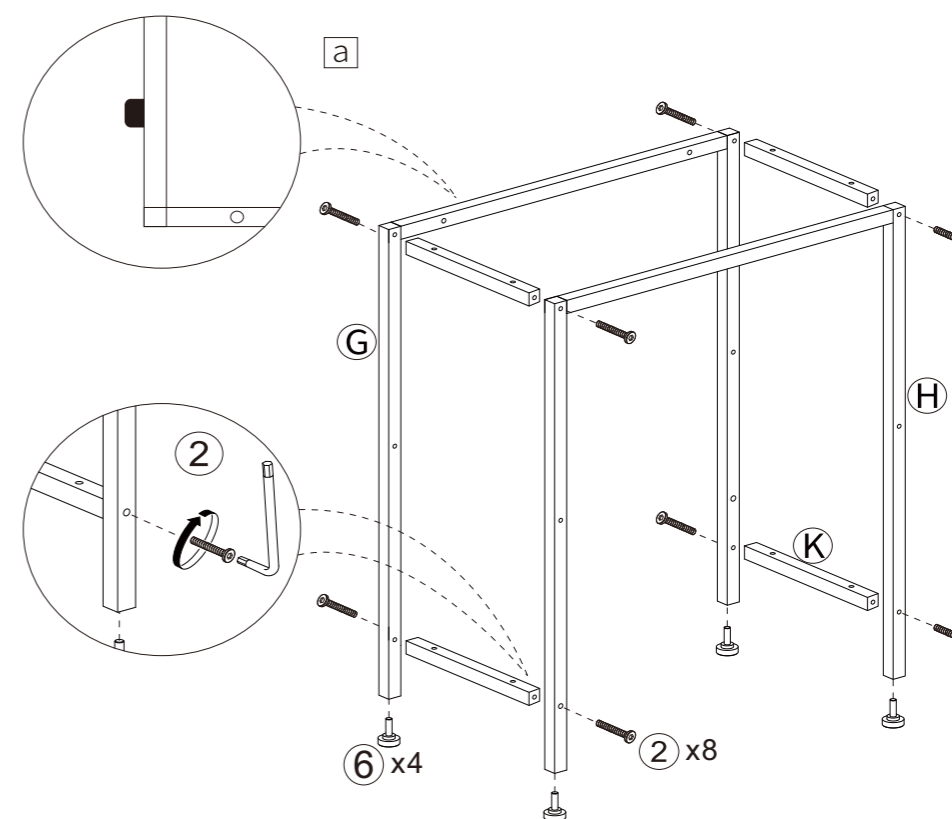



2

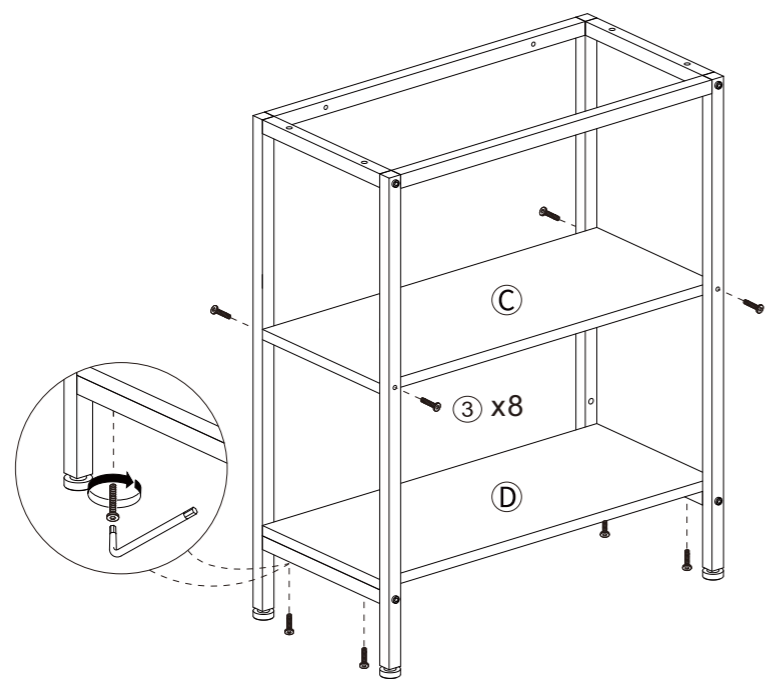

4

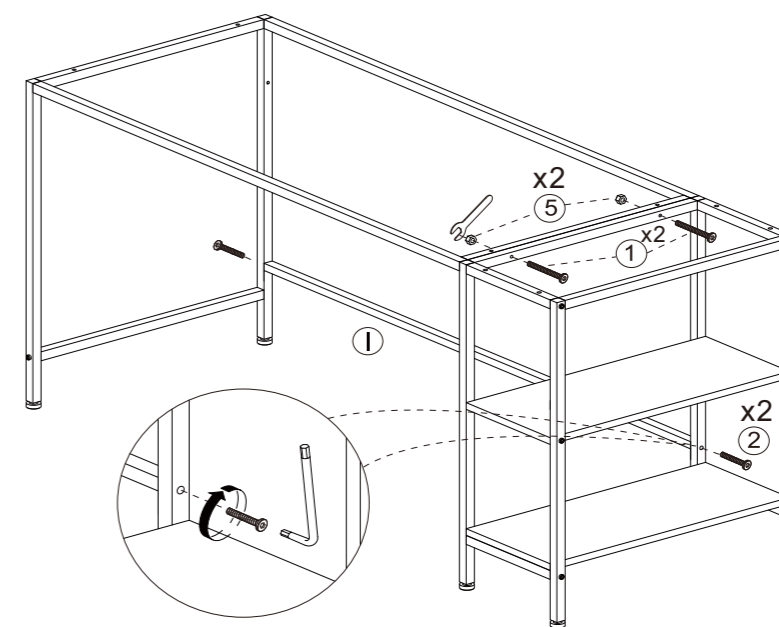

3

b) Tenga en cuenta: dos orificios para tornillos sobresalientes deben estar en el mismo lado para instalar los componentes de conexión del puntal F y E.

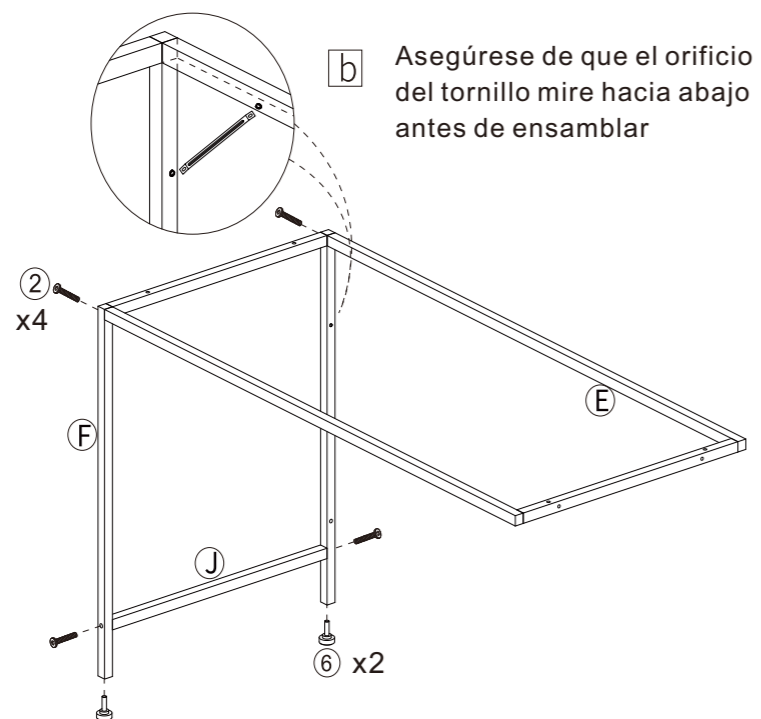

5

- c) Si los orificios del marco del escritorio y el tablero del escritorio no coinciden, cambie la dirección del tablero y vuelva a intentarlo.
- d) El escritorio solo se puede fijar con tornillos ②. NO atornille con fuerza en este paso.

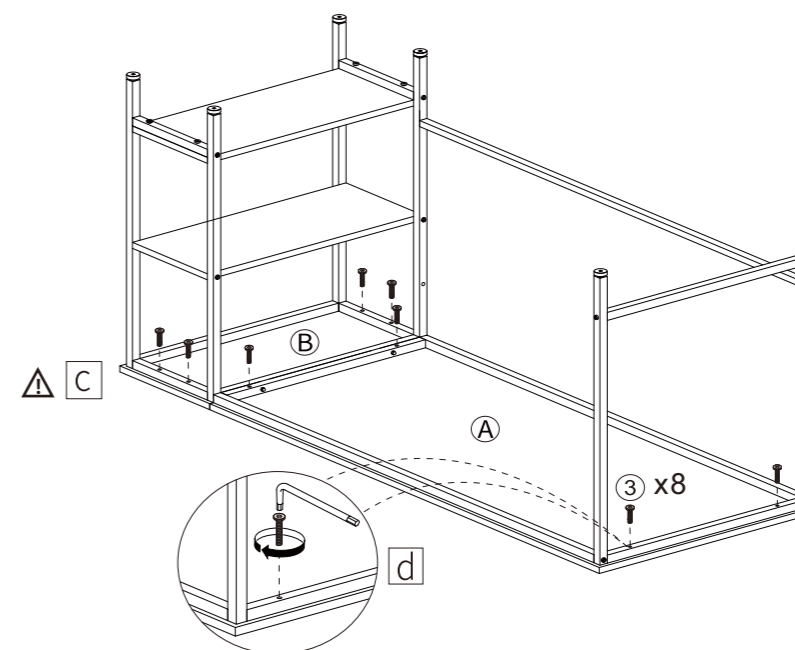



6

e) Apriete todos los tornillos cuando no haya espacio entre las dos tablas.

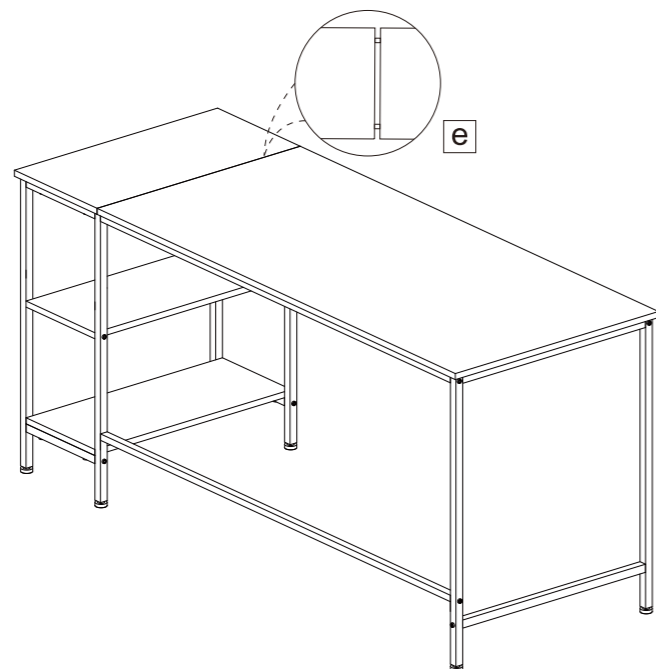

8

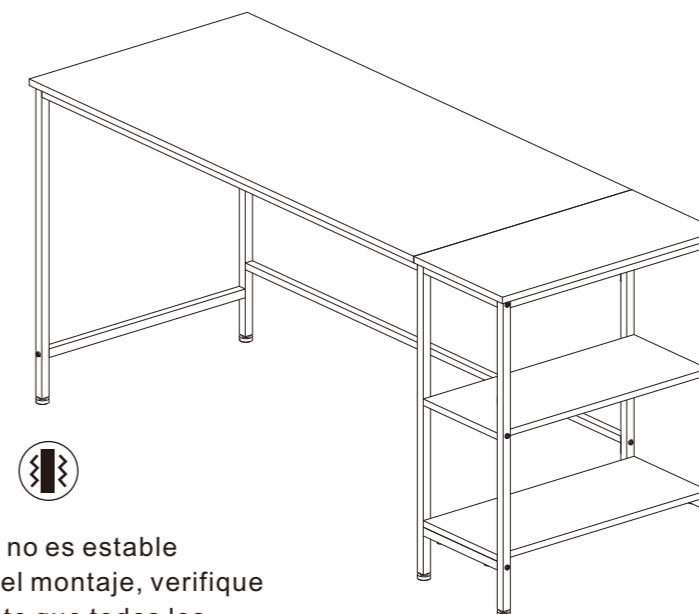

Si la mesa no es estable después del montaje, verifique nuevamente que todos los tornillos estén apretados.

7

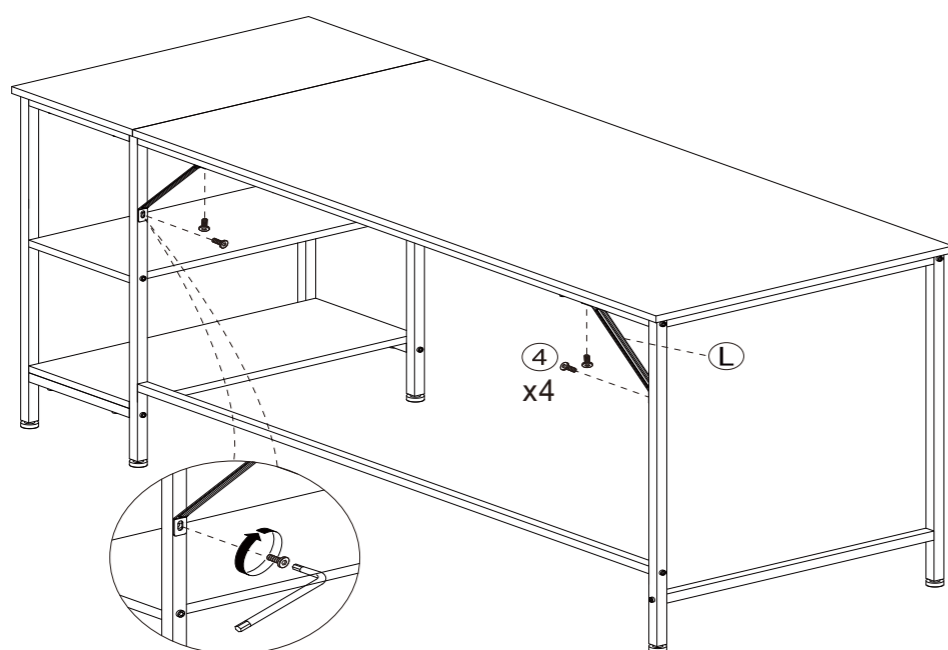

Coloque los dos tornillos en los orificios para tornillos al mismo tiempo y luego apriete el tornillo

9

## Reciclaje y Disposición



Este producto no se puede desechar como basura doméstica. Para evitar perjuicio al medio ambiente, se debe reciclar el producto. Utilice el sistema de reciclaje pertinente disponible para usted o contactar con el distribuidor o fabricante para ayuda de reciclaje.