

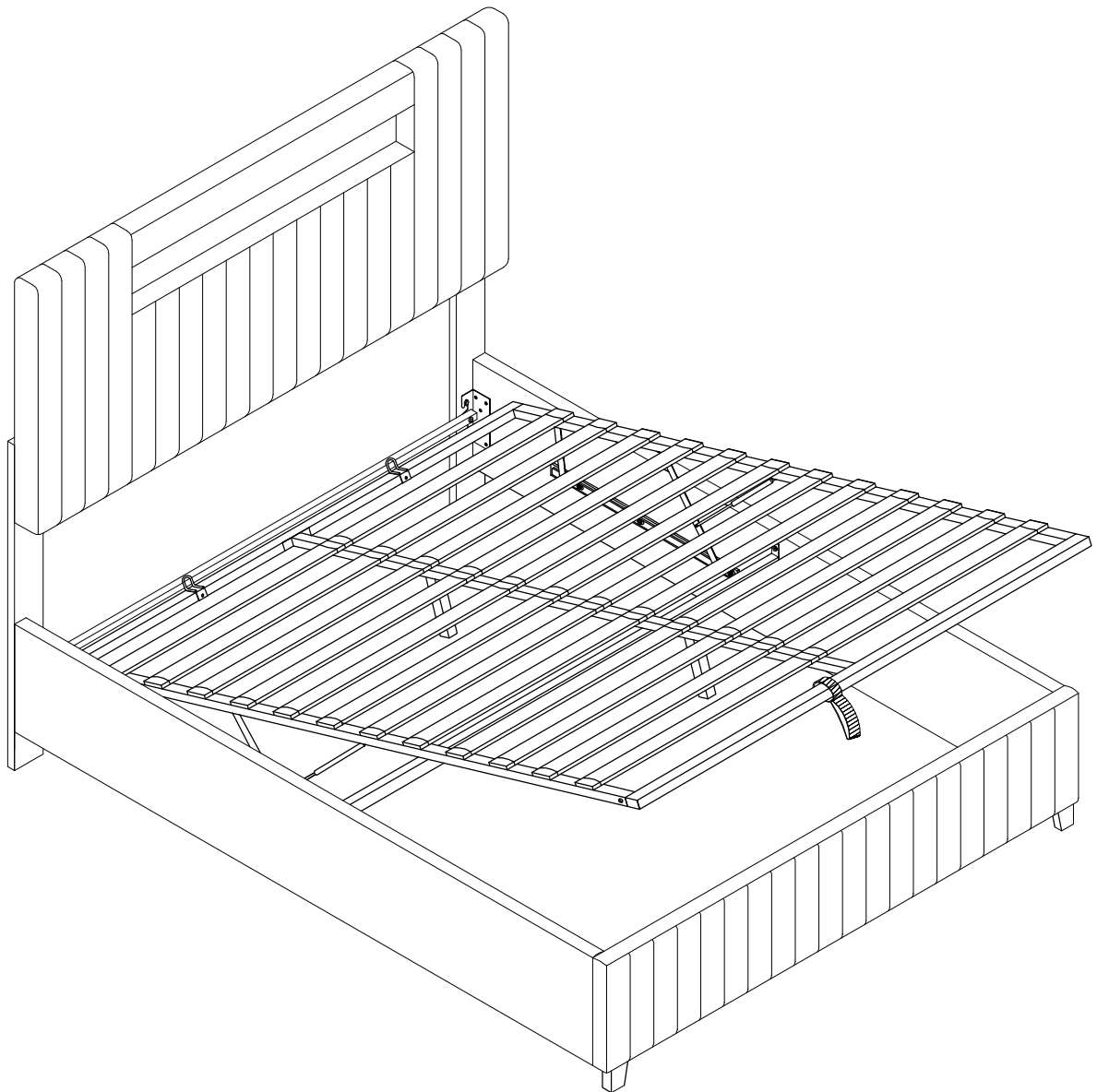

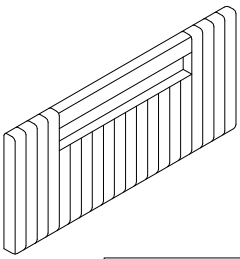

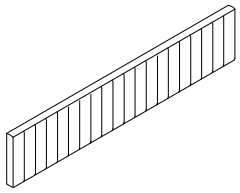

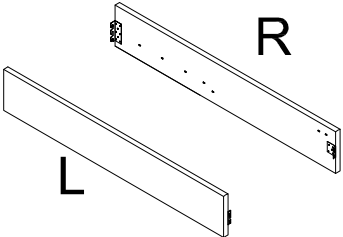

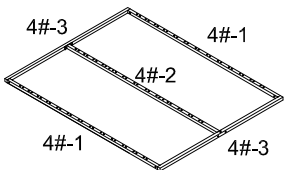
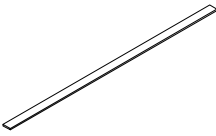

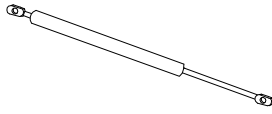
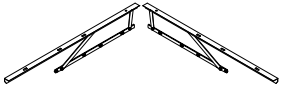

# ASSEMBLY INSTRUCTIONS

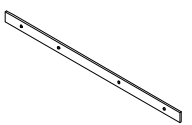
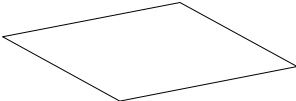

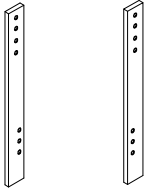
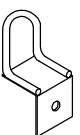
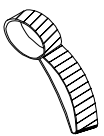

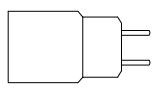

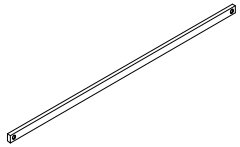
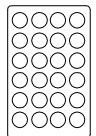
306

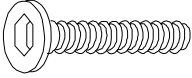
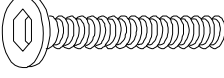
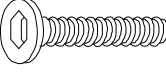

# Parts List

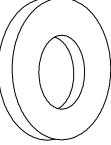
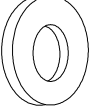
<p><b>1:HEAD BOARD</b></p>  <p style="text-align: center; border: 1px solid black; padding: 5px;"><b>1PC</b></p>	<p><b>2:FOOT BOARD</b></p>  <p style="text-align: center; border: 1px solid black; padding: 5px;"><b>1PC</b></p>	<p><b>3:SIDE RAIL</b></p>  <p style="text-align: center; border: 1px solid black; padding: 5px;"><b>2PCS</b></p>	<p><b>4:BEDSTEAD KD</b></p>  <p style="text-align: center; border: 1px solid black; padding: 5px;"><b>1SET</b></p>
<p><b>5:SLAT</b></p>  <p style="text-align: center; border: 1px solid black; padding: 5px;"><b>12PCS</b></p>	<p><b>6:ANGLE IRON</b></p>  <p style="text-align: center; border: 1px solid black; padding: 5px;"><b>2PCS</b></p>	<p><b>7:STEAM MOVING BAR (ASSEMBLED WITH ALREADY)</b></p>  <p style="text-align: center; border: 1px solid black; padding: 5px;"><b>2PCS</b></p>	<p><b>8:STEAM MOVING MECHANICA 2PCS</b></p>  <p style="text-align: center; border: 1px solid black; padding: 5px;"><b>2PCS</b></p>
<p><b>9:SQUARE TUBE 1PC</b></p>  <p style="text-align: center; border: 1px solid black; padding: 5px;"><b>1PC</b></p>	<p><b>10:LEG</b></p>  <p style="text-align: center; border: 1px solid black; padding: 5px;"><b>2PCS</b></p>	<p><b>11 :</b></p>  <p style="text-align: center; border: 1px solid black; padding: 5px;"><b>1PC</b></p>	<p><b>12:</b></p>  <p style="text-align: center; border: 1px solid black; padding: 5px;"><b>2PCS</b></p>
<p><b>13 : Non-Moven Bed Base</b></p>  <p style="text-align: center; border: 1px solid black; padding: 5px;"><b>1PC</b></p>	<p><b>14: LEG</b></p>  <p style="text-align: center; border: 1px solid black; padding: 5px;"><b>2PCS</b></p>	<p><b>15:HB LEG</b></p>  <p style="text-align: center; border: 1px solid black; padding: 5px;"><b>2PCS</b></p>	<p><b>16:WINKEL-EISEN</b></p>  <p style="text-align: center; border: 1px solid black; padding: 5px;"><b>2PCS</b></p>
<p><b>17:</b></p>  <p style="text-align: center; border: 1px solid black; padding: 5px;"><b>1PC</b></p>	<p><b>18:SLAT CAP</b></p>  <p style="text-align: center; border: 1px solid black; padding: 5px;"><b>24PCS</b></p>	<p><b>19: POWER</b></p>  <p style="text-align: center; border: 1px solid black; padding: 5px;"><b>1PC</b></p>	<p><b>20:</b></p>  <p style="text-align: center; border: 1px solid black; padding: 5px;"><b>1PC</b></p>
<p><b>21:</b></p>  <p style="text-align: center; border: 1px solid black; padding: 5px;"><b>1PC</b></p>	<p><b>22: REMOTE CONTROL</b></p>  <p style="text-align: center; border: 1px solid black; padding: 5px;"><b>1PC</b></p>		

## HARDWARE LIST:

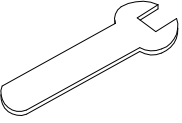

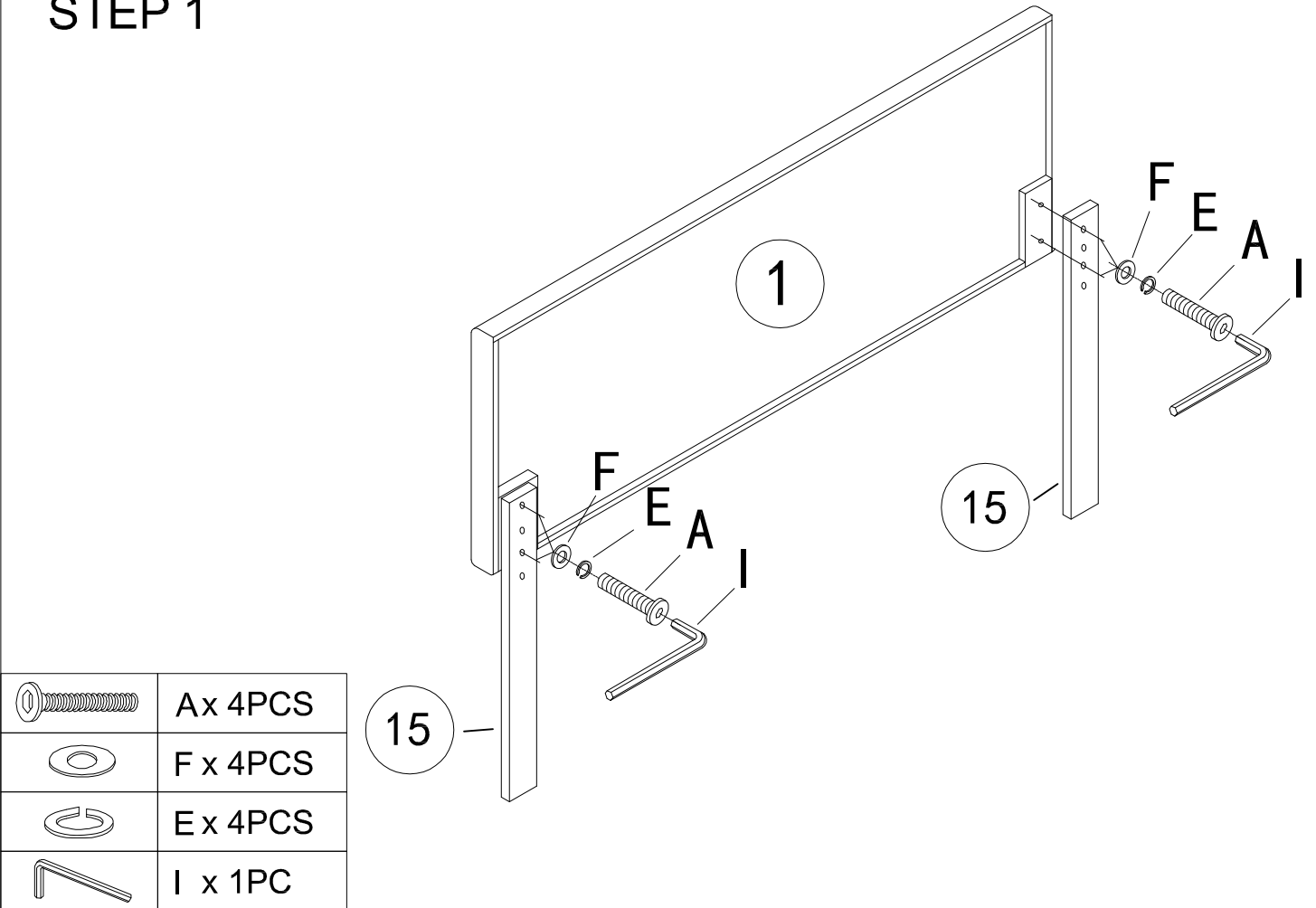

<p><b>A: BOLT</b></p>  <p>5/16"*50mm    24+2PCS</p>	<p><b>B: BOLT</b></p>  <p>5/16"*30mm    10+1PCS</p>	<p><b>C: BOLT</b></p>  <p>1/4"*35mm    8+1PCS</p>	<p><b>D: BOLT</b></p>  <p>1/4"*15mm    10+1PCS</p>
<p><b>E: SPRING WASHER</b></p>  <p>5/16"*13mm    34+2PCS</p>	<p><b>F: FLAT WASHER</b></p>  <p>5/16"*19mm    34+2PCS</p>	<p><b>G: FLAT WASHER</b></p>  <p>1/4"*16mm    18+2PCS</p>	<p><b>H: NUT</b></p>  <p>5/16"    14+2PCS</p>
<p><b>I: ALLEN KEY</b></p>  <p>M5*100mm    1PC</p>	<p><b>J: ALLEN KEY</b></p>  <p>M4*100mm    1PC</p>	<p><b>K: ALLEN KEY</b></p>  <p>5/16"    1PC</p>	

# STEP 1

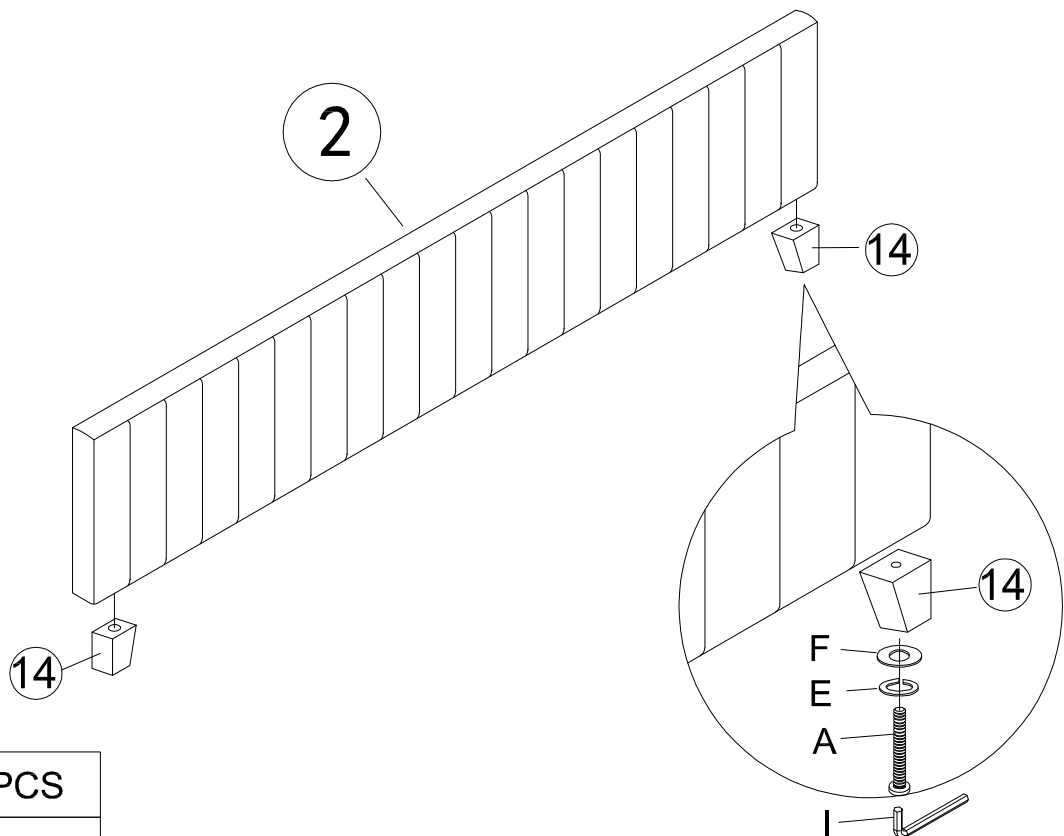

# STEP 2



	A x 2PCS
	F x 2PCS
	E x 2PCS
	I x 1PC

### STEP 3

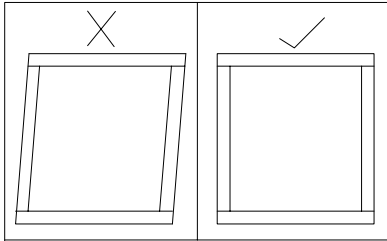

**Note:** Ensure that footboard, headboard and side rails are square.

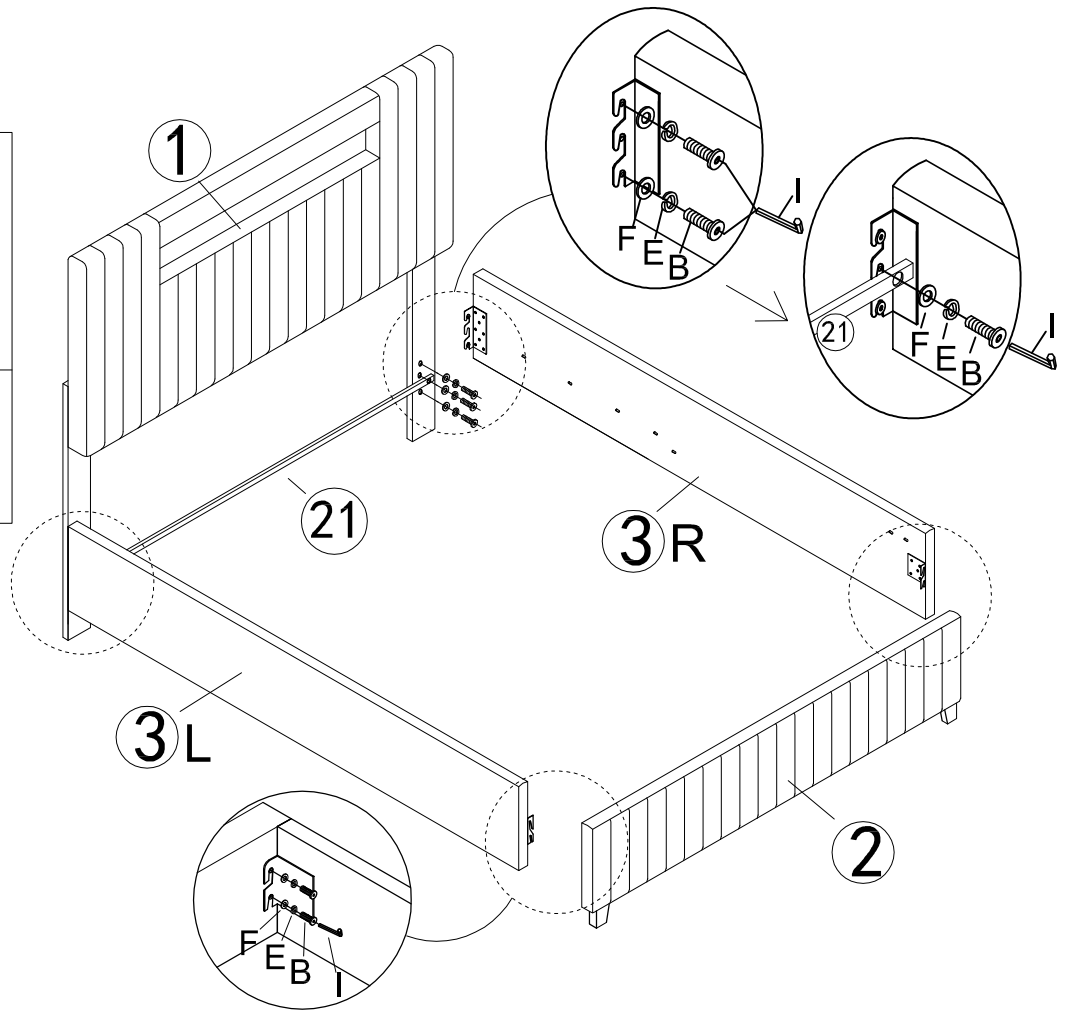

	B x 10PCS
	F x 10PCS
	E x 10PCS
	I x 1PC

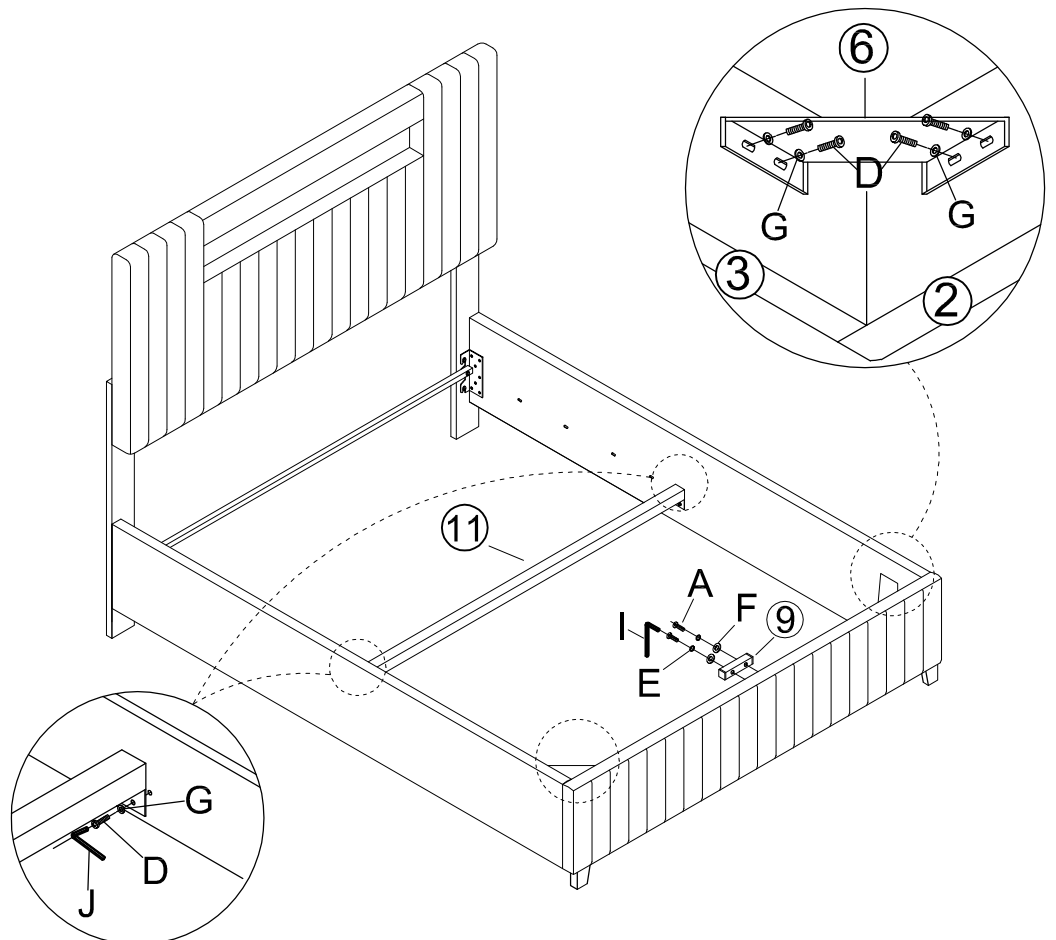

### STEP 4

	A x 2PCS
	D x 10PCS
	F x 2PCS
	G x 10PCS
	E x 2PCS
	I x 1PC
	J x 1PC
	6 x 2PCS
	9 x 1PC

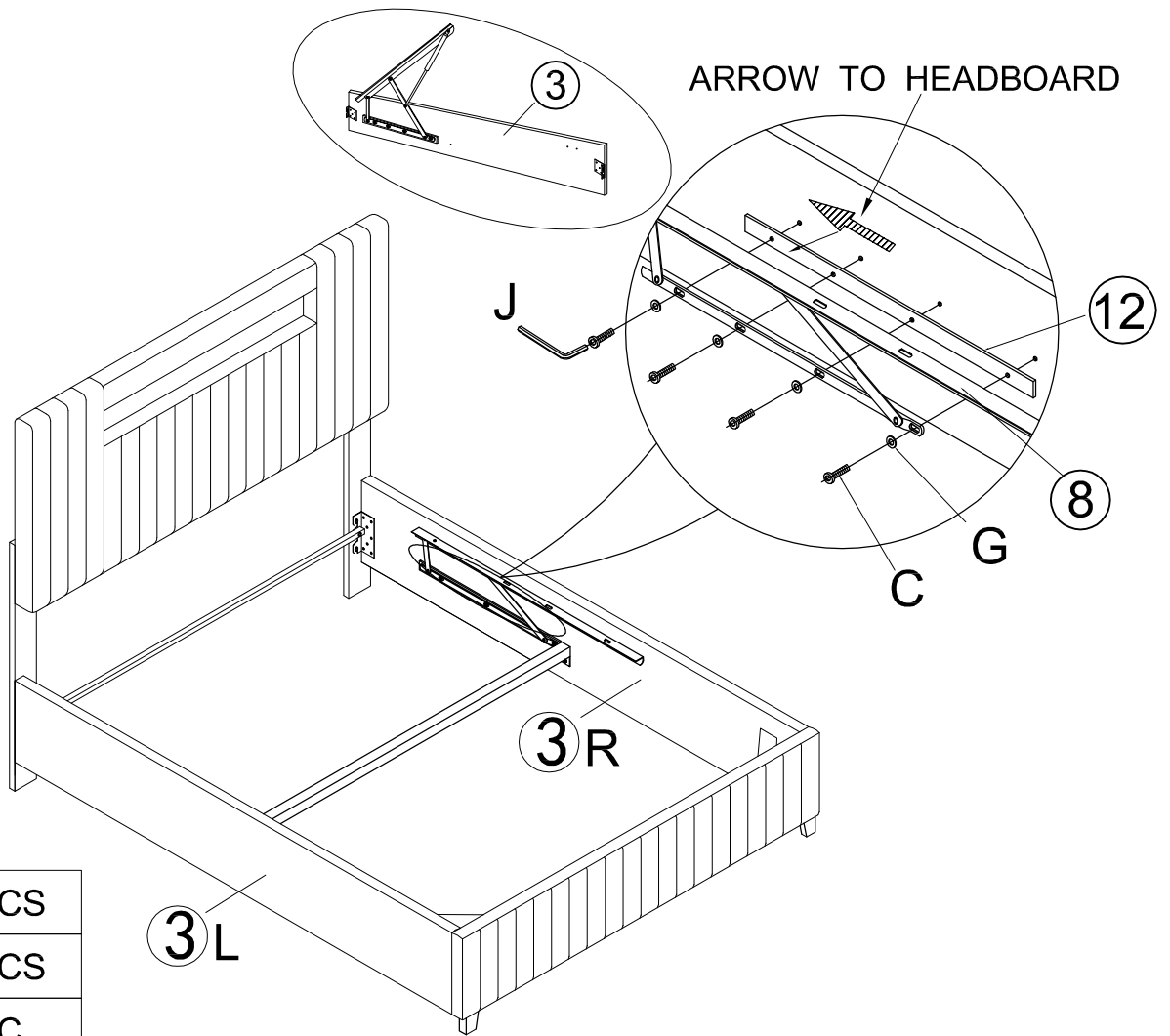

# STEP 5







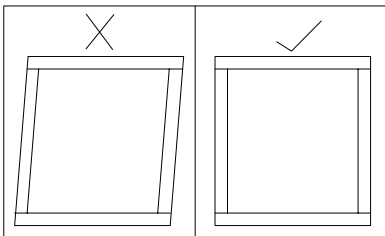



	C x 8PCS
	G x 8PCS
	J x 1PC

# STEP 6



Note: Ensure that Frame assembly s are square.

	A x 10PCS
	F x 10PCS
	E x 10PCS
	H x 10PCS
	I x 1PC
	K x 1PC
	16 x 2PCS
	17 x 1PC

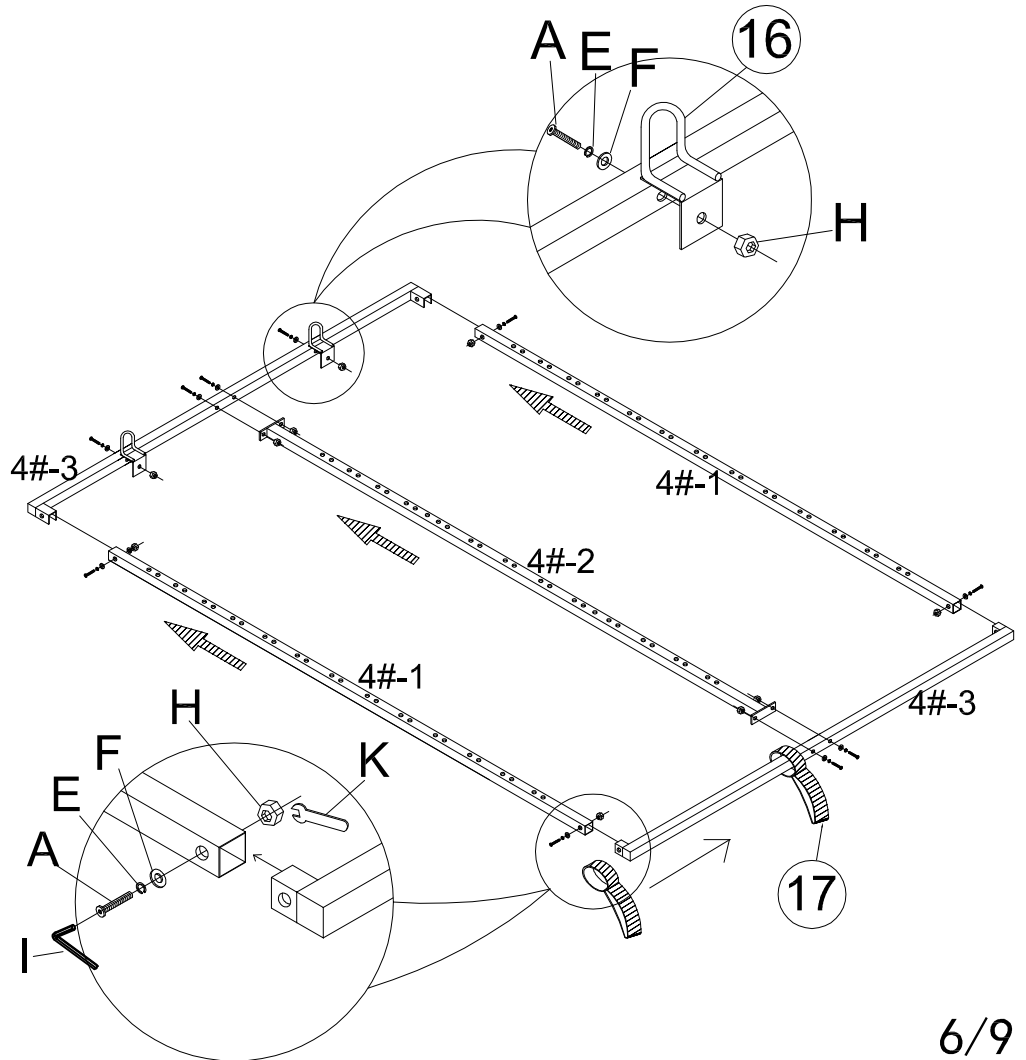

# STEP 7

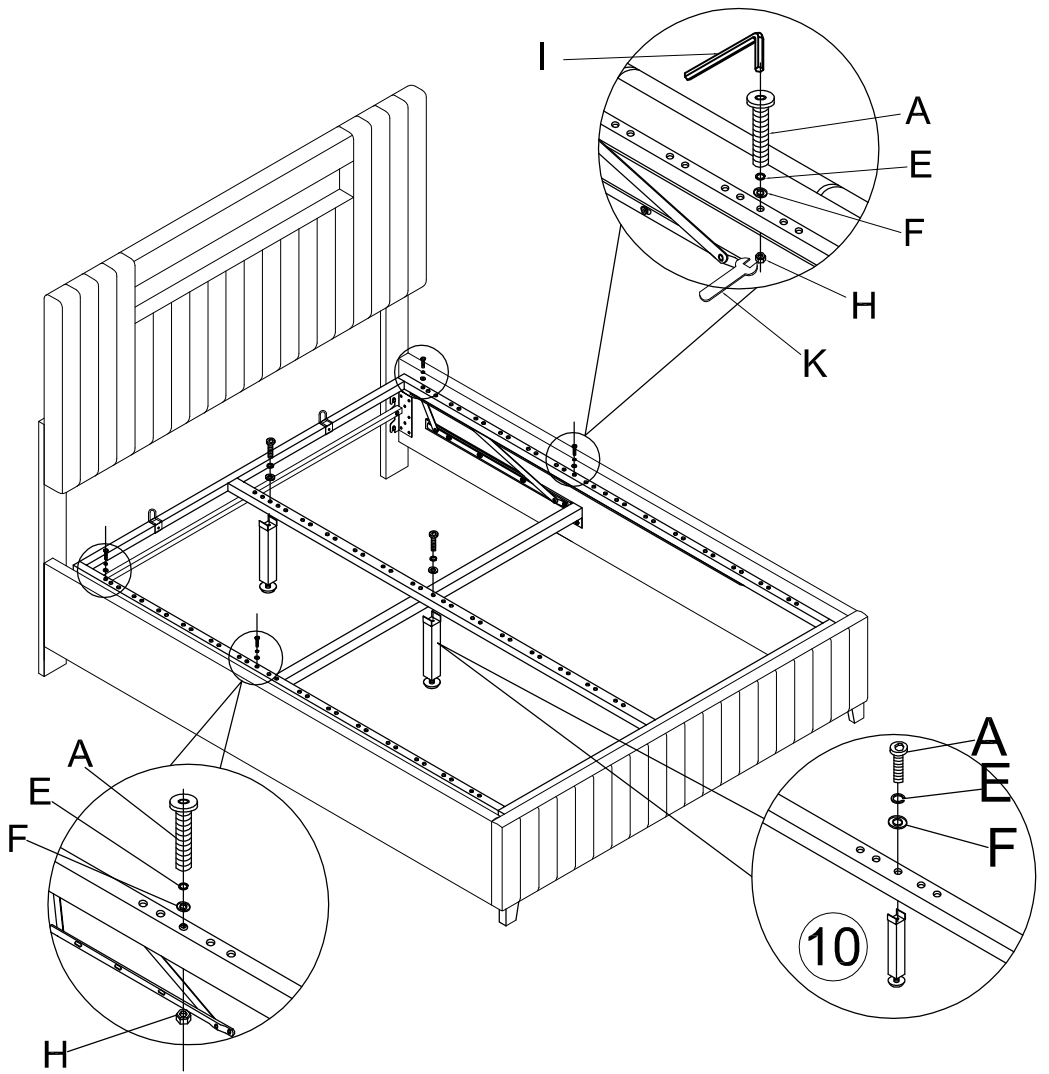

	A x 6PCS
	F x 6PCS
	H x 6PCS
	H x 4PCS
	I x 1PC
	K x 1PC

# STEP 8

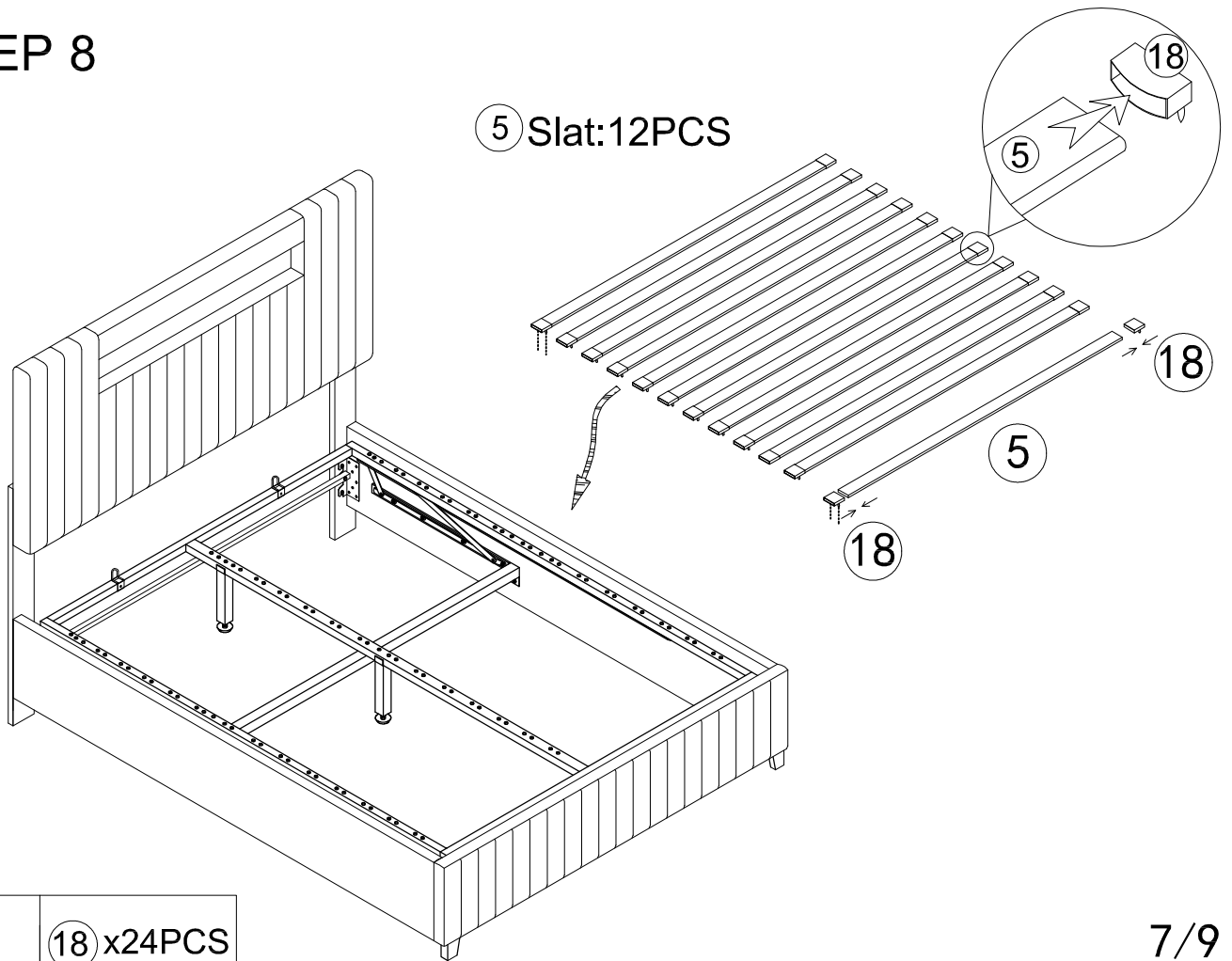

	⑤ x 24PCS
--	-----------

# STEP 9

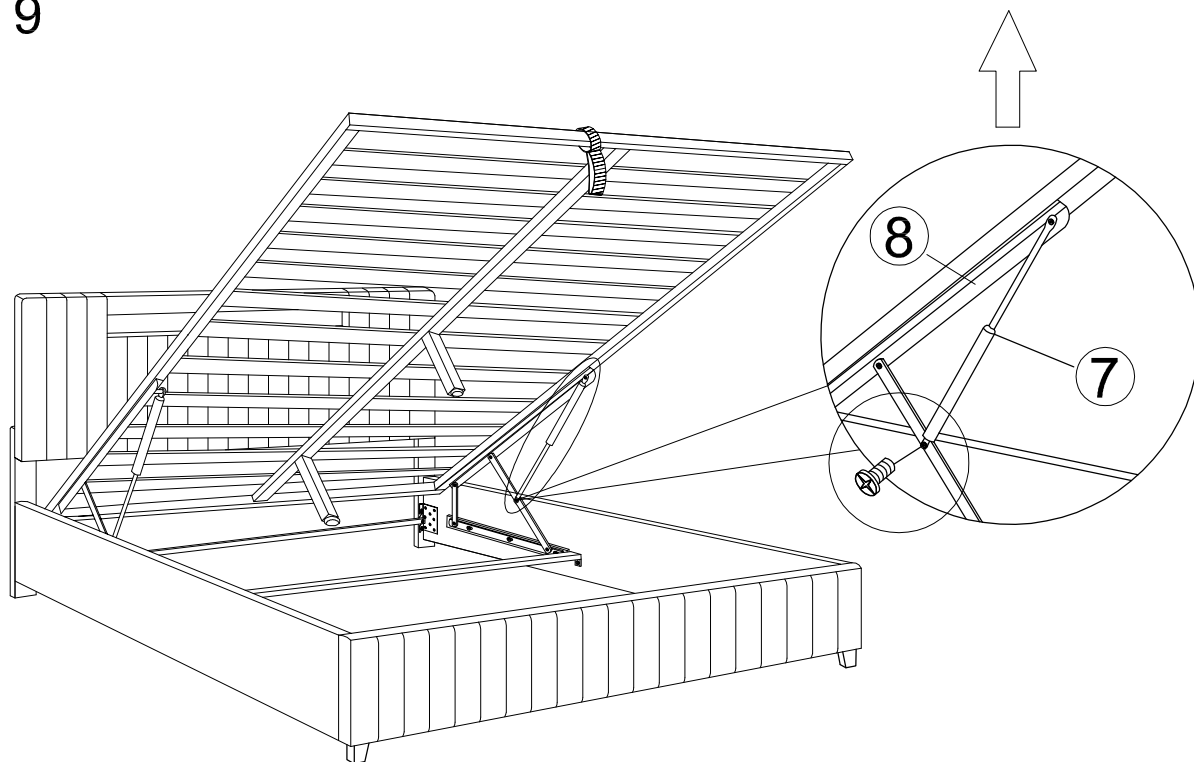

# STEP 10

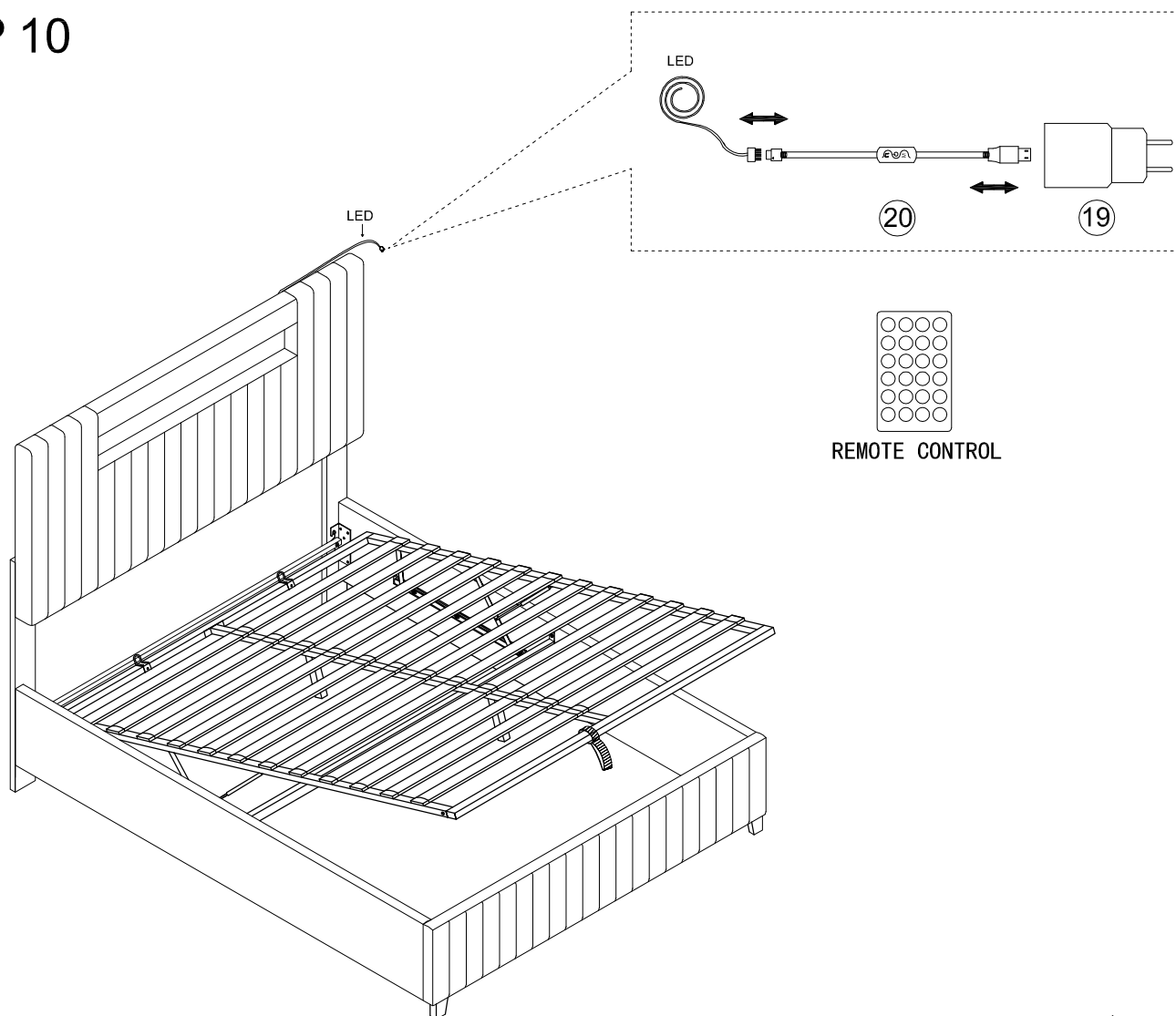



# STEP 11

