

- (PL) Instrukcja montażu
- (RO) Instrucțiuni de montaj
- (FR) Notice de montage
- (CZ) Montážní návod
- (TR) Montaj talimatı
- (IT) Istruzioni di montaggio
- (SK) Návod na montáž
- (RU) Инструкция по монтажу

- (D) Montageanleitung
- (NL) Handleiding voor de montage
- (HU) Szerelési útmutató
- (GB) Assembly instructions

Service • Assistenza • Dienstverlening • Serwis
Servis • Szerviz • Сервисная служба

Name • Nom • Nome • Naam •
Nazwa • Jméno • Názov • Név •
Denumire • İsim • Название

Nr. • No. • N° • Номер • Č • Sz

Typ • Type • Тип • Tipus • Tipo •
Тип

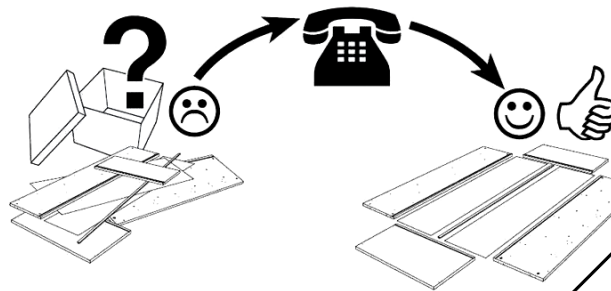

7 ≠ **8**
4 ≠ **5**

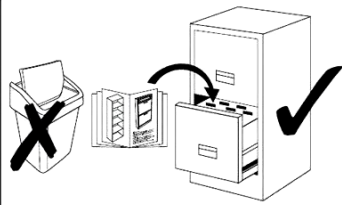

oben/top

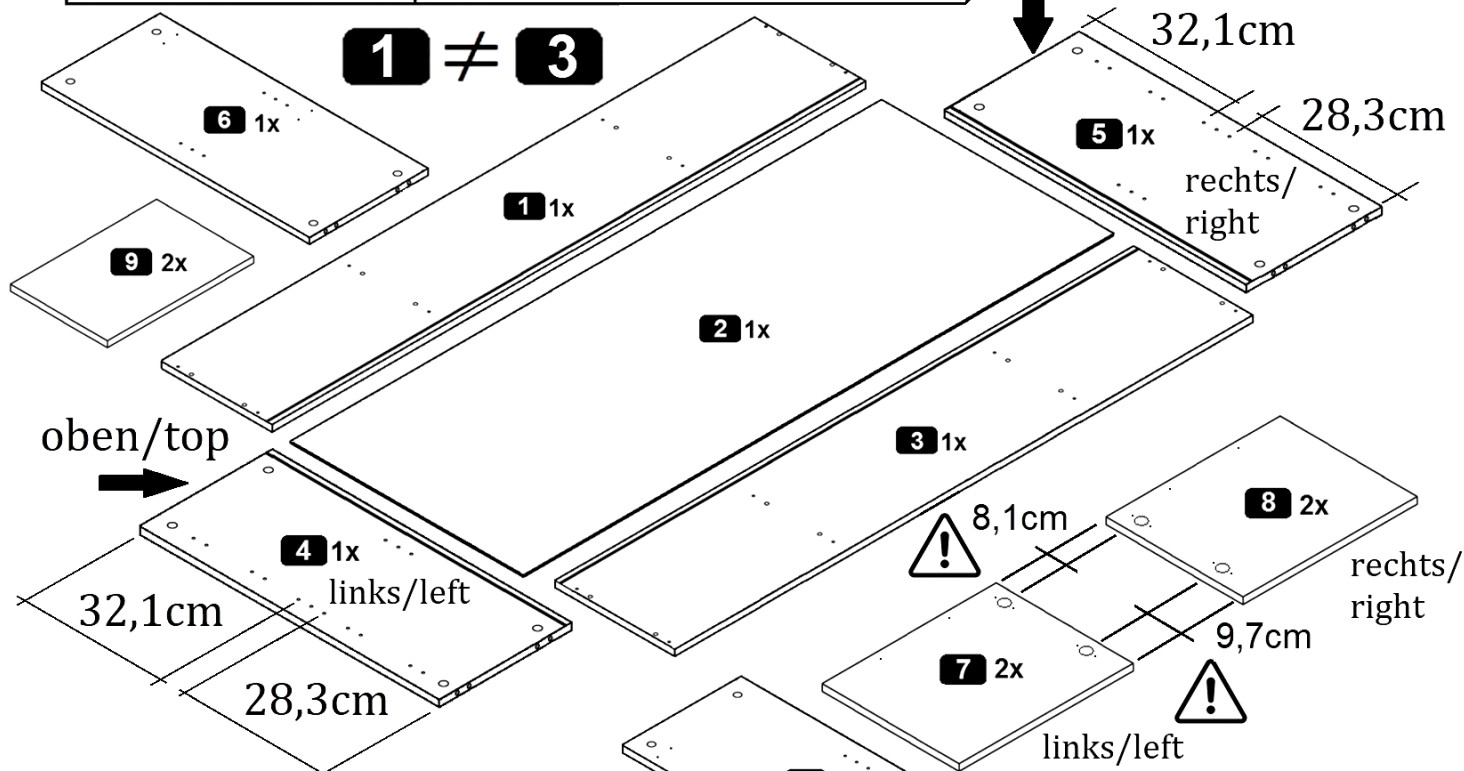

1	1x	ca. 1663 x 350 mm
2	1x	ca. 1644 x 680 mm
3	1x	ca. 1663 x 330 mm
4	1x	ca. 668 x 330 mm
5	1x	ca. 668 x 330 mm
6	1x	ca. 668 x 315 mm
7	2x	ca. 338 x 459 mm
8	2x	ca. 338 x 459 mm

9	2x	ca. 437 x 300 mm
10	1x	ca. 668 x 315 mm
11	4x	ca. 737 x 166 mm
12	4x	ca. 707 x 307 mm
13-L	4x	ca. 310 x 88 mm
13-M	4x	ca. 695 x 88 mm
13-R	4x	ca. 310 x 88 mm



A 8,0 x 30 mm 16x	B 16x	C 16x	D 8x	E 3,5 x 13 mm 16x	F 8x	G 4,0 x 20 mm 8x
H Ø35 Kr.0 8x	I h=2 8x	J 8x	K 2,7 x 20 mm 12x	L 17 x 310 mm 8x	M 6,3 x 13 mm 16x	N M4,0 x 9 mm 8x
O 1x						

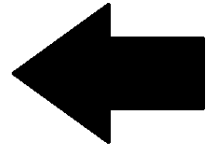
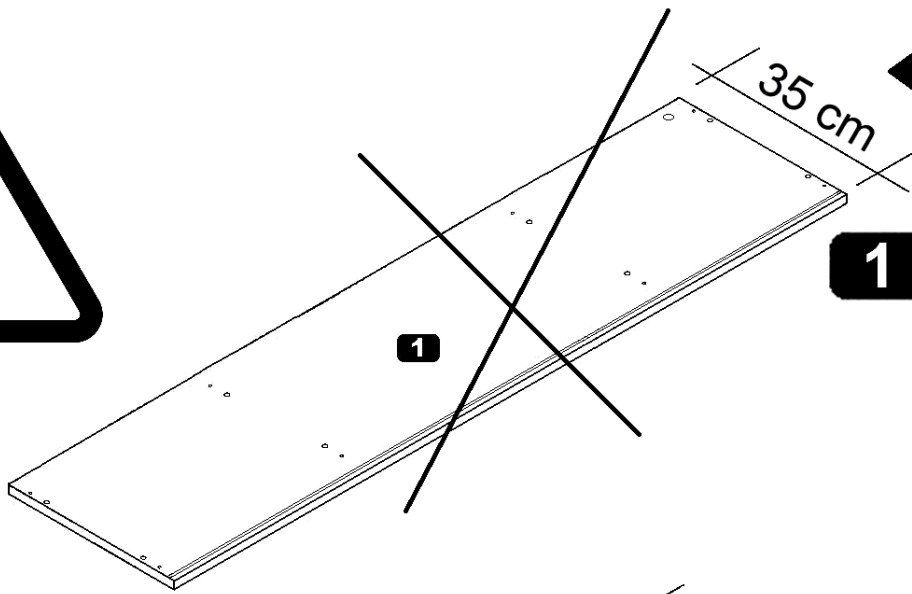

1 = ✗ 😞

1

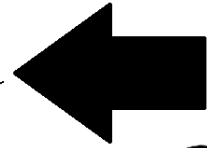
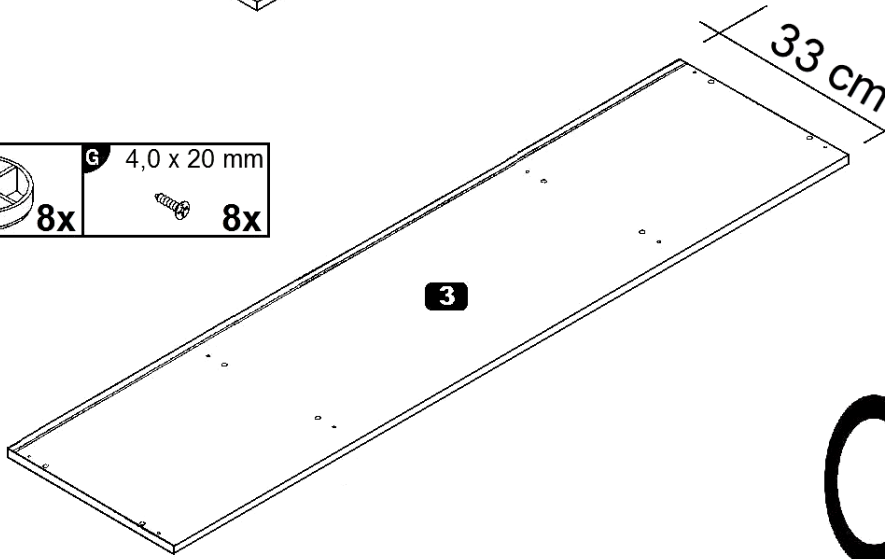
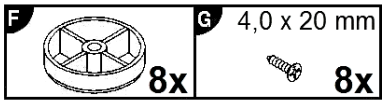



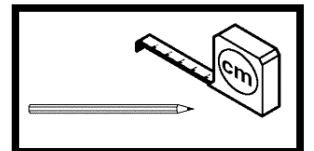
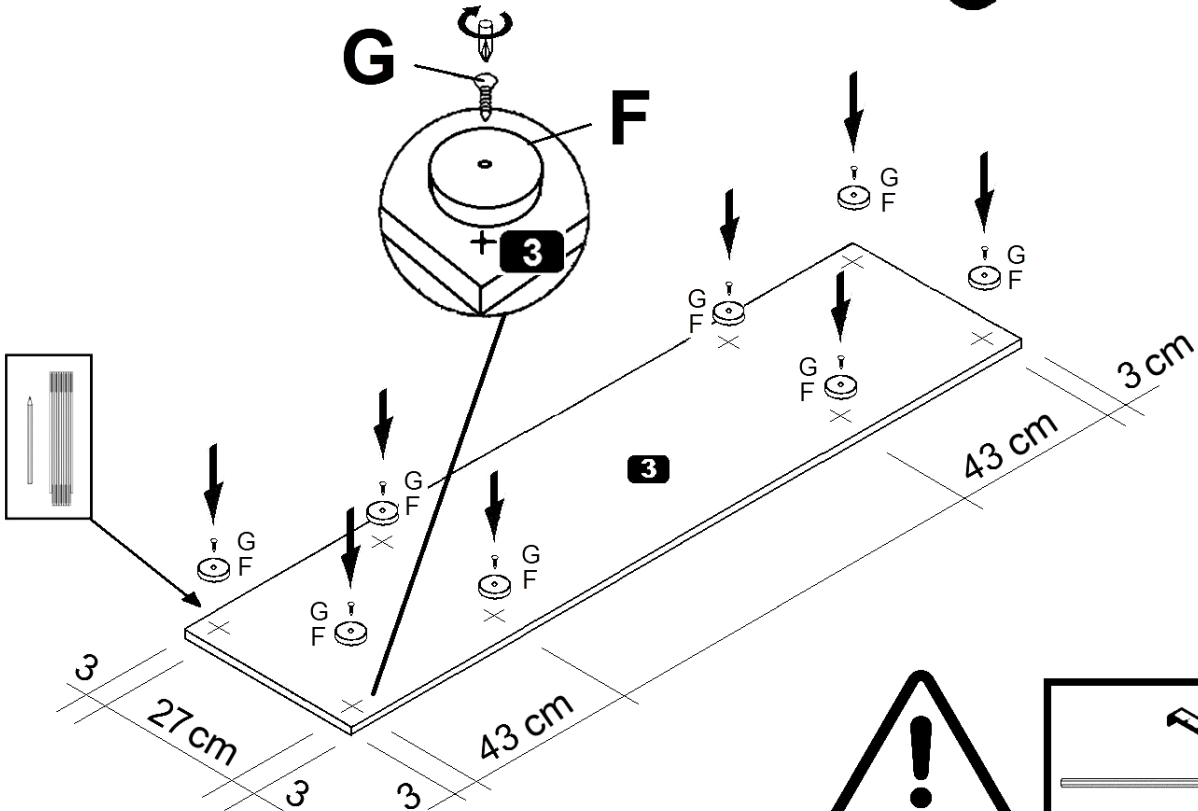

3 = 😊 ✓

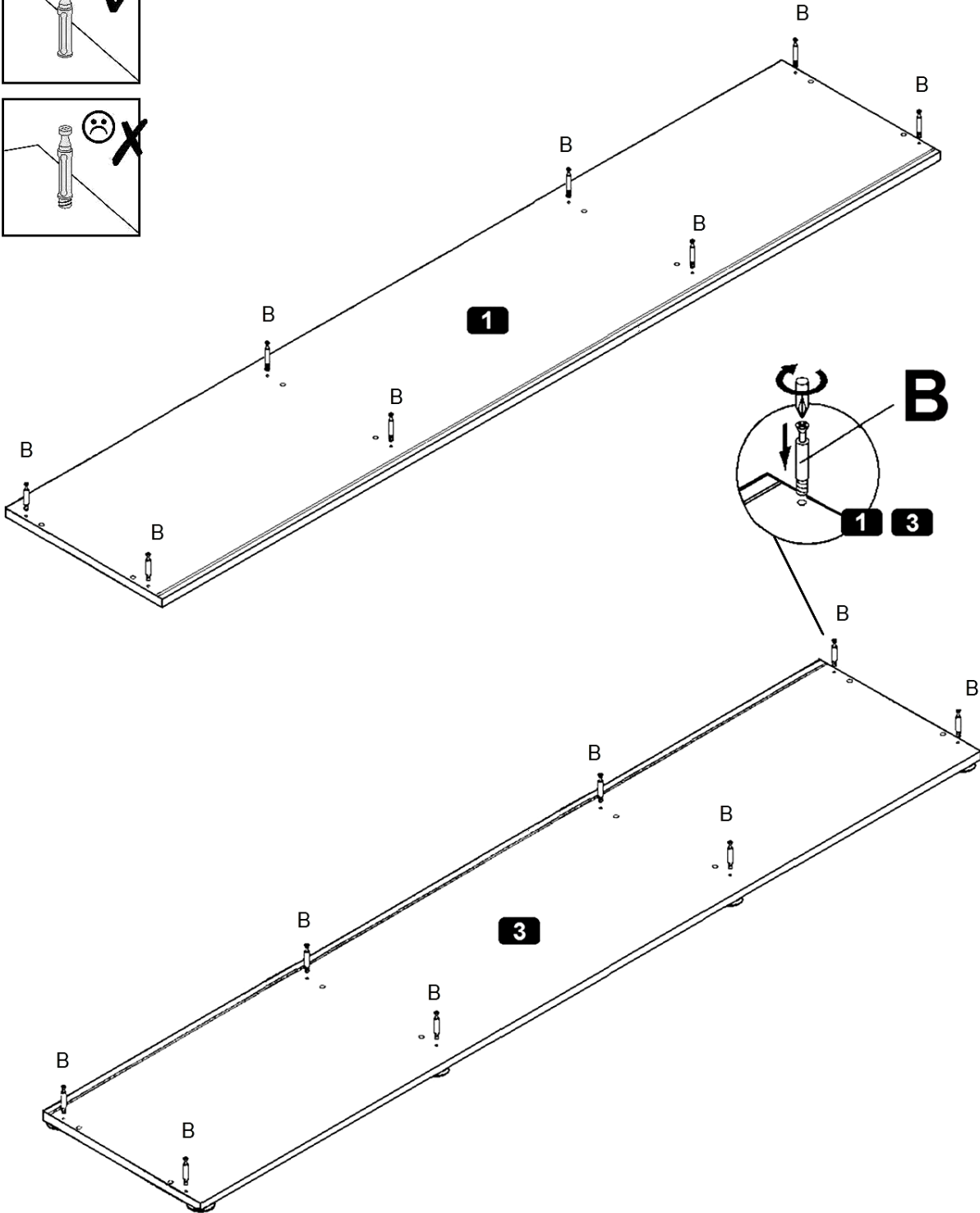
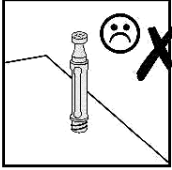
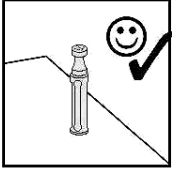
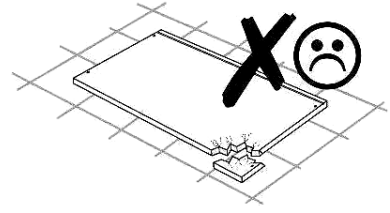
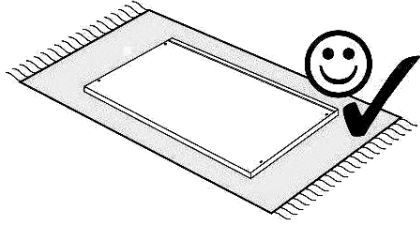
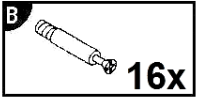

2

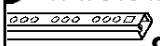

5

A 8,0 x 30 mm  8x	C  8x	L 17 x 310 mm  8x	M 6,3 x 13 mm  16x
---	---	---	--

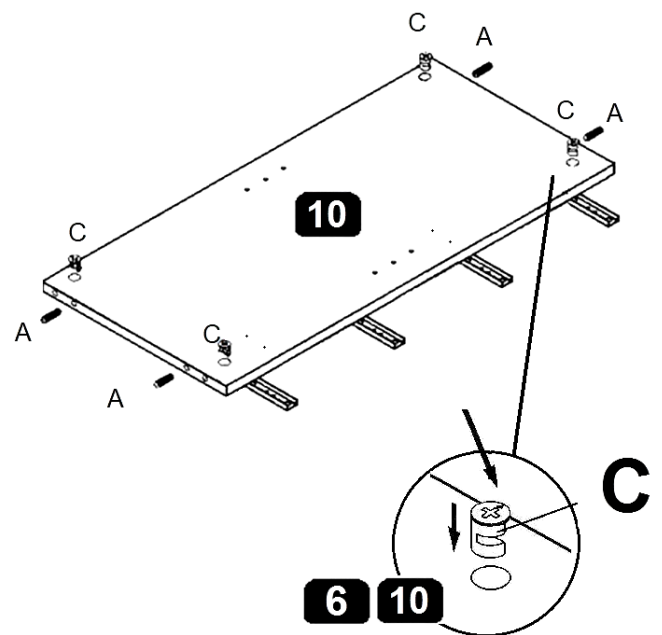
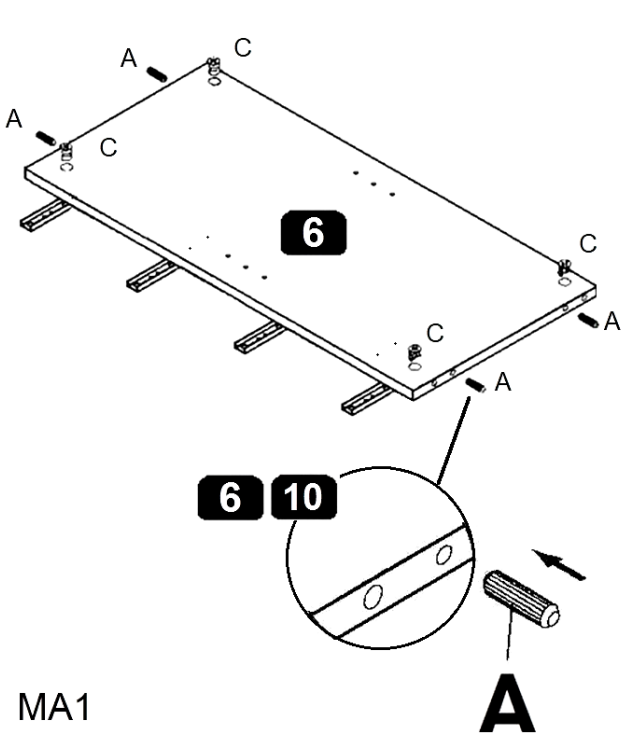
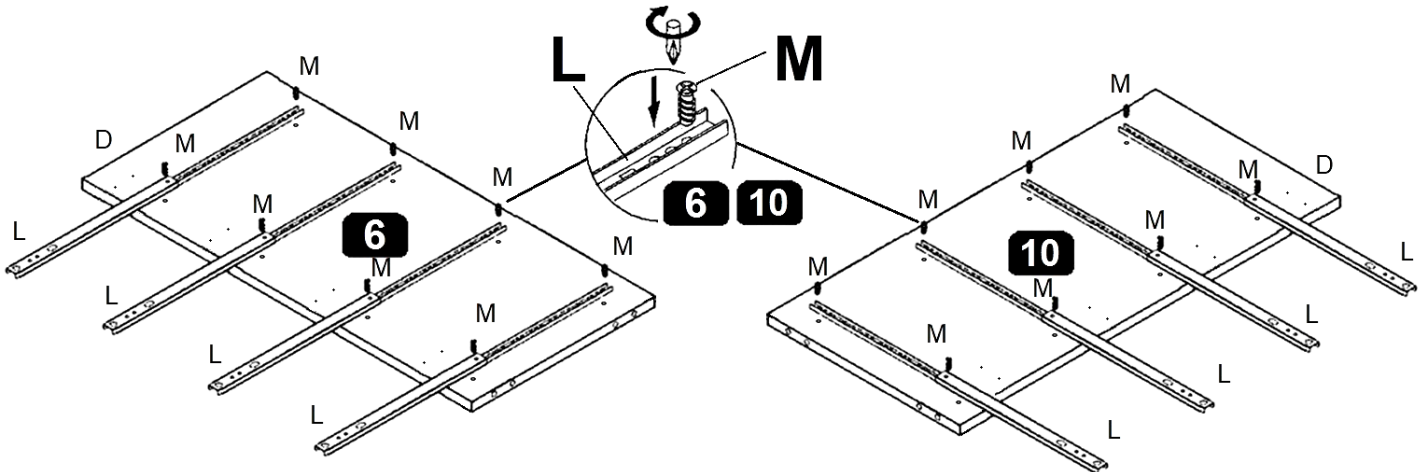
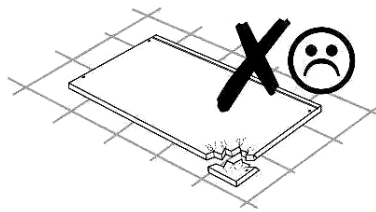
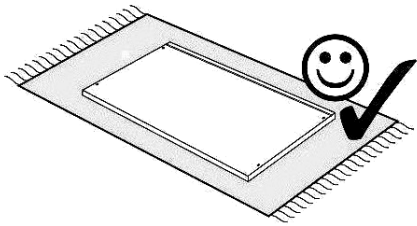

MA1

6

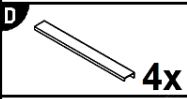
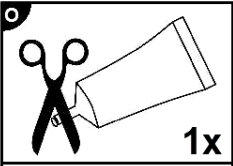
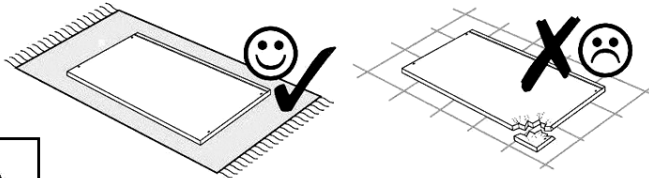

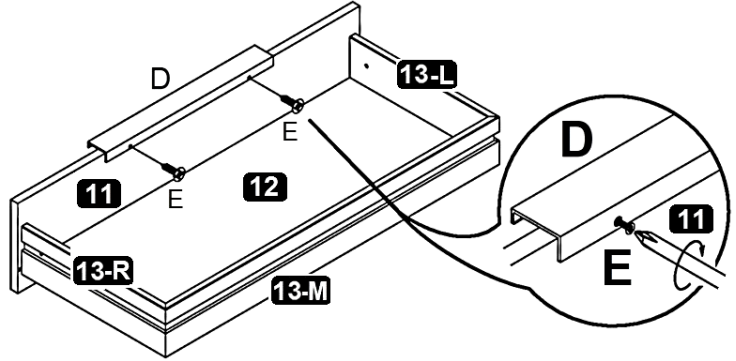
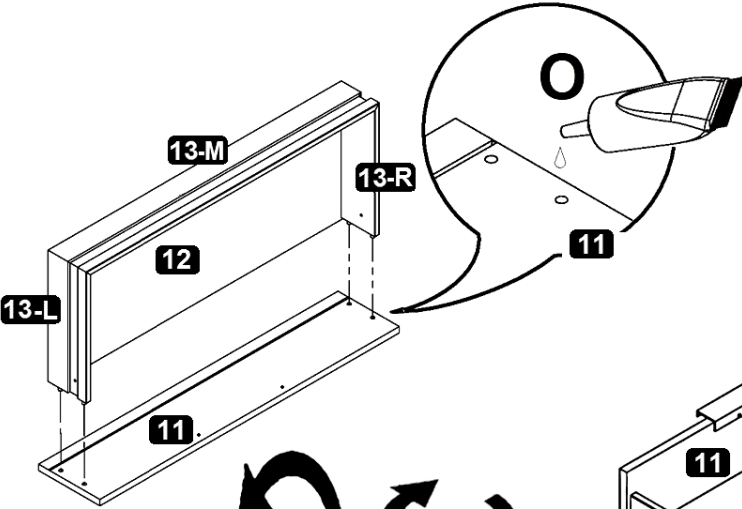
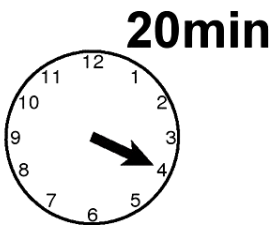
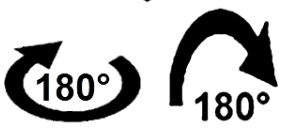
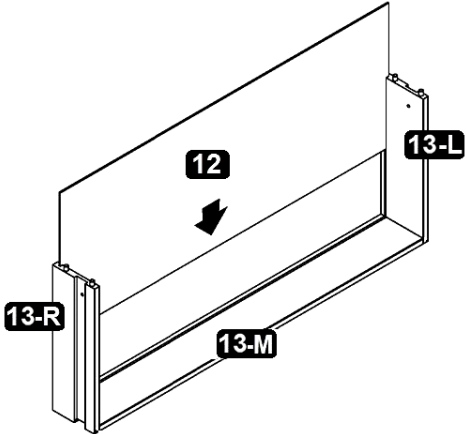
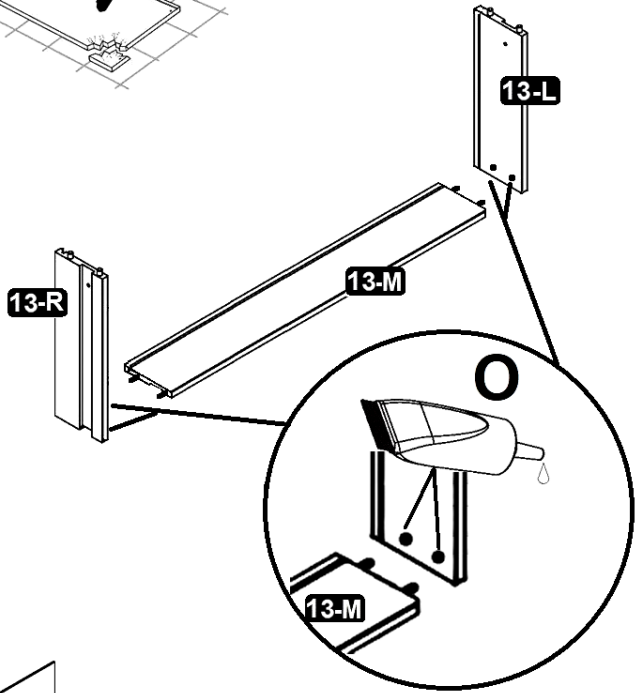

- D Leim
- GB Glue
- FR Colle
- IT Colla
- NL Lijm
- PL Klej
- CZ Lepidlo
- SK Glej
- HU Enyv
- RO Adeziv
- TR Tutkal
- RU Клей

4x



MA1

7

J		8x
K	2,7 x 20 mm	
		12x

4 = links / left
5 = rechts / right

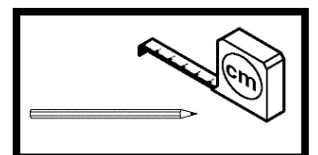
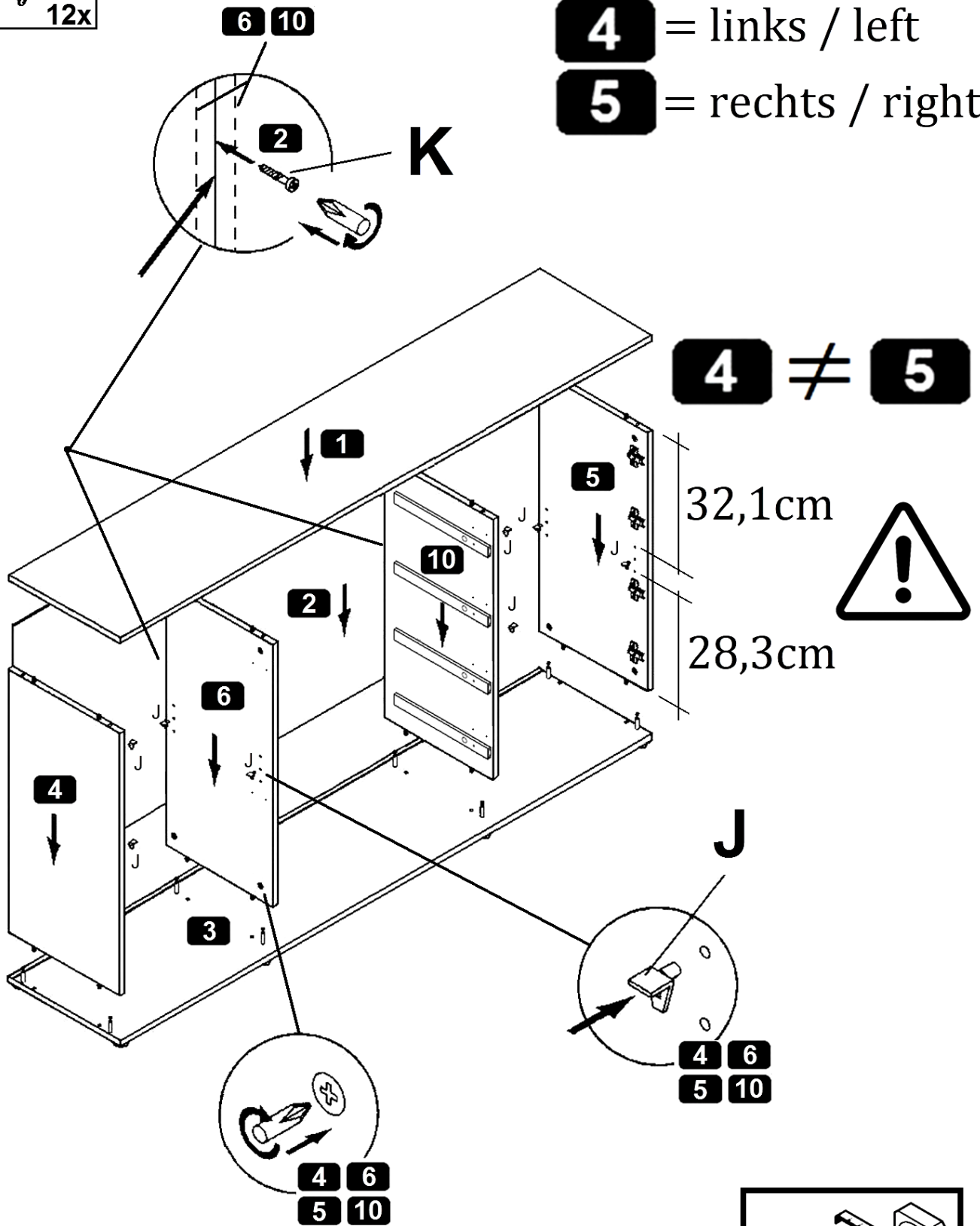

8

N M4,0 x 9 mm

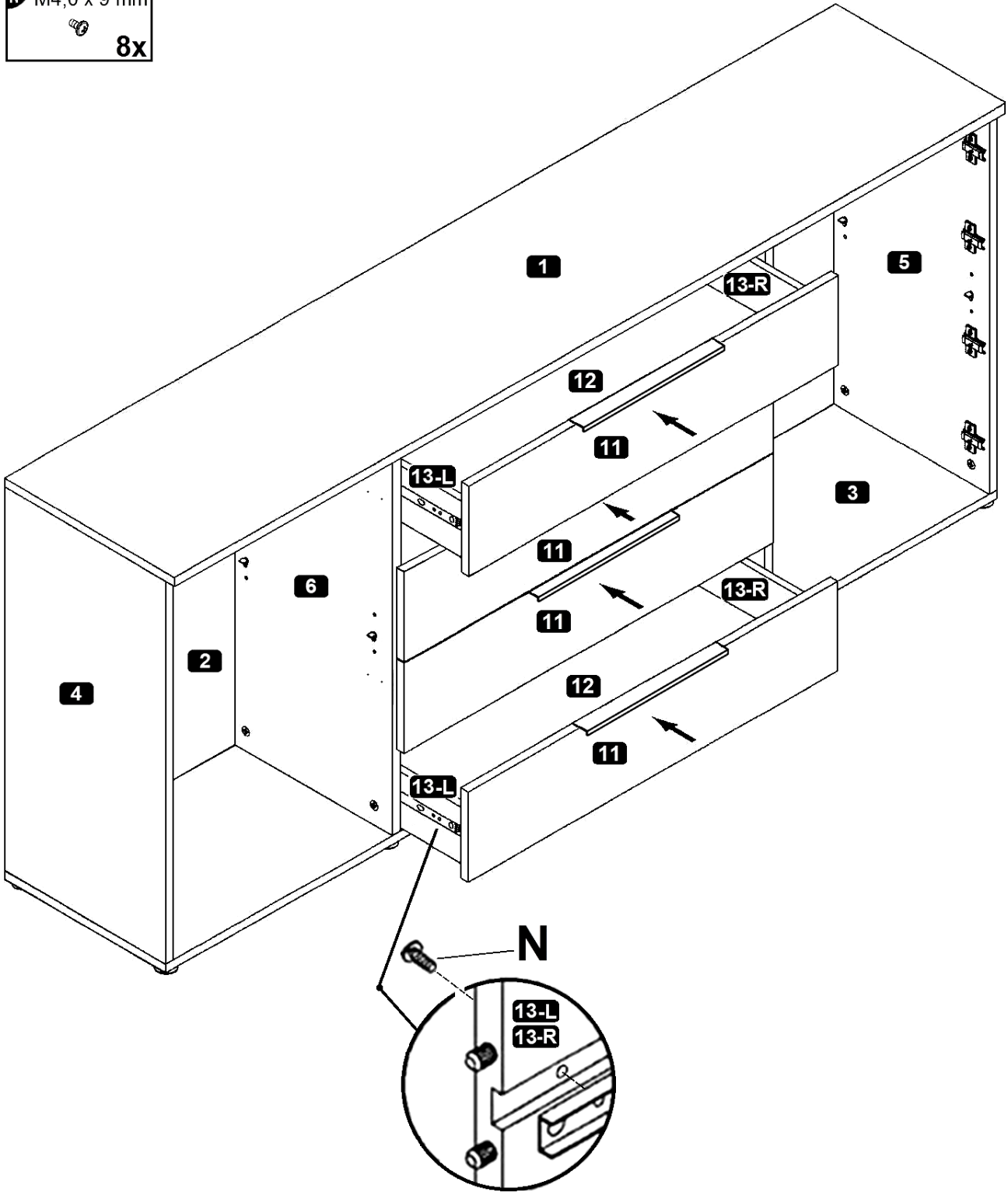
8x

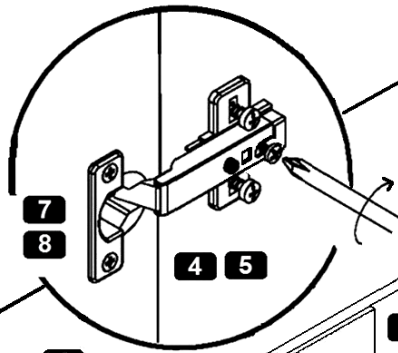
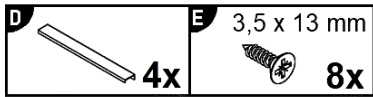

9

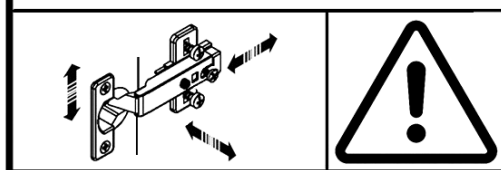
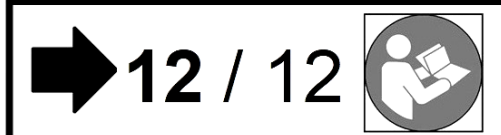
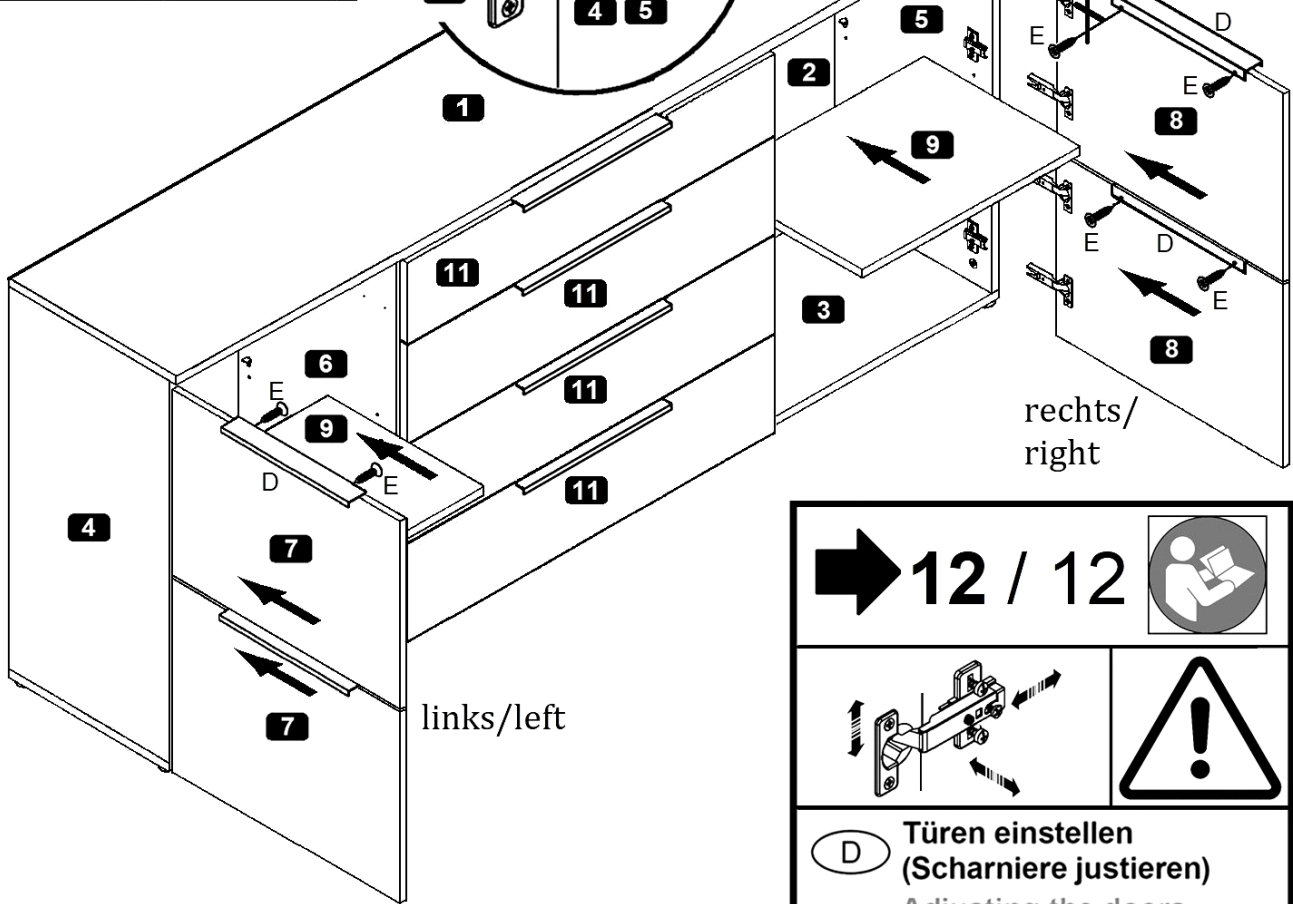

8,1 cm



- (D) **Türen einstellen**
(Scharniere justieren)
- (GB) **Adjusting the doors**
(adjusting the hinges)
- (FR) **Régler les portes**
(ajuster les charnières)
- (IT) **Sistemare le porte**
(regolare le cerniere)
- (NL) **Deuren instellen**
(scharnieren afstellen)
- (PL) **Nastawić drzwi**
(wyregulować zawiasy)
- (CZ) **Vyrovnejte dvířka**
(seřid'te závěsy)
- (RO) **Nastavenie dverí**
(nastavenie závesov)
- (HU) **Állítsa be az ajtókat**
(állítsa be a zsanérokot)
- (SK) **Reglare uši**
(ajustare balamale)
- (TR) **Kapıların ayarlanması**
(mentешelerin seviye ayarı)
- (RU) **Регулировка дверей**
(регулировка шарнира)

10

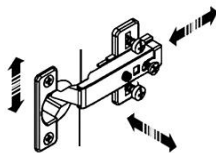

(D) Türen einstellen
(Scharniere justieren)

(GB) Adjusting the doors
(adjusting the hinges)

(FR) Régler les portes
(ajuster les charnières)

(IT) Sistemare le porte
(regolare le cerniere)

(NL) Deuren instellen
(scharnieren afstellen)

(PL) Nastawić drzwi
(wyregulować zawiasy)

(CZ) Vyrovnajte dvířka
(seřid'te závěsy)

(RO) Nastavenie dverí
(nastavenie závesov)

(HU) Állítsa be az ajtókat
(állítsa be a zsanérokat)

(SK) Reglare uši
(ajustare balamale)

(TR) Kapıların ayarlanması
(menteşelerin seviye ayarı)

(RU) Регулировка дверей
(регулировка шарнира)

