

Installationsanleitung/Installation Instruction/Instruction d'installation
SIDEBOARD-N620P191602/N620P191603

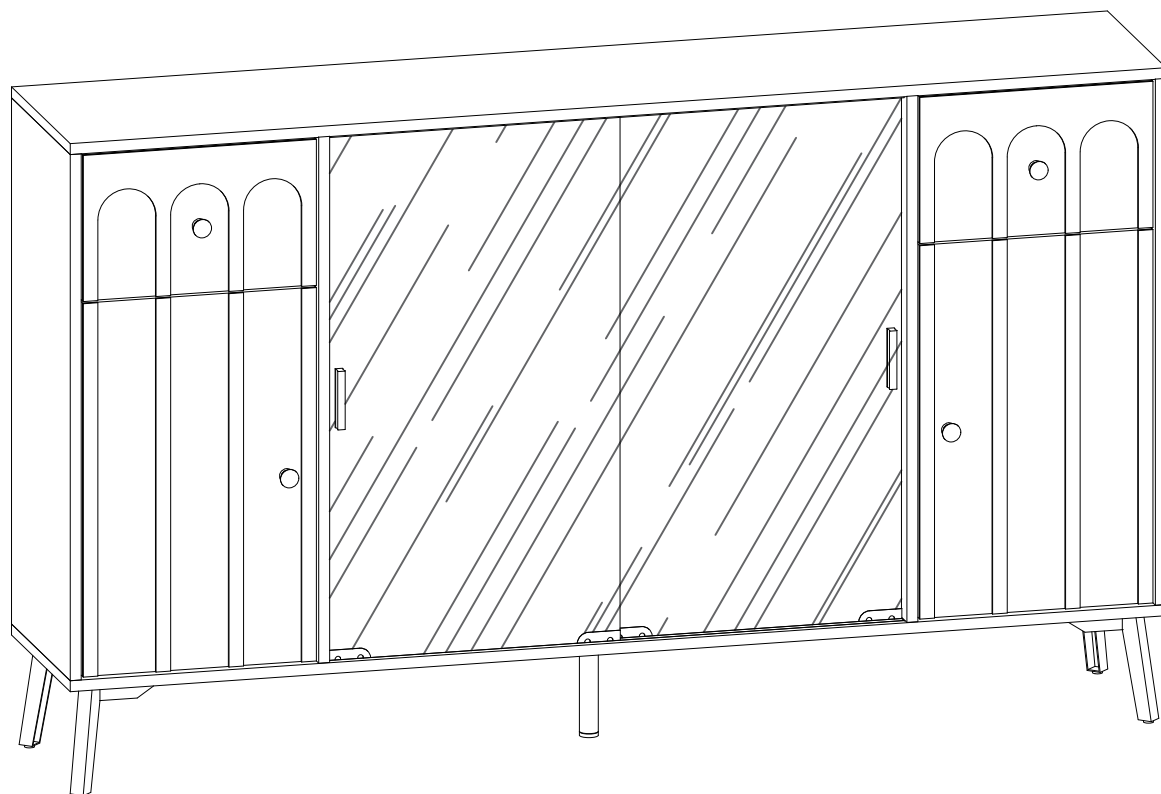

DE: Unser Produkt wird Ihnen in 2 Paketen geliefert. Die Lieferzeiten dieser 2 Pakete können abweichen, bitte haben Sie etwas Geduld und vielen Dank für Ihr Verständnis.

UK: Our product will be delivered to you in 2 packages. The delivery times of these 2 packages may differ, please be patient and thank you for your understanding.

FR: Notre produit vous sera livré en 2 colis. Les délais de livraison de ces 2 colis peuvent différer, soyez patient et merci pour votre compréhension.

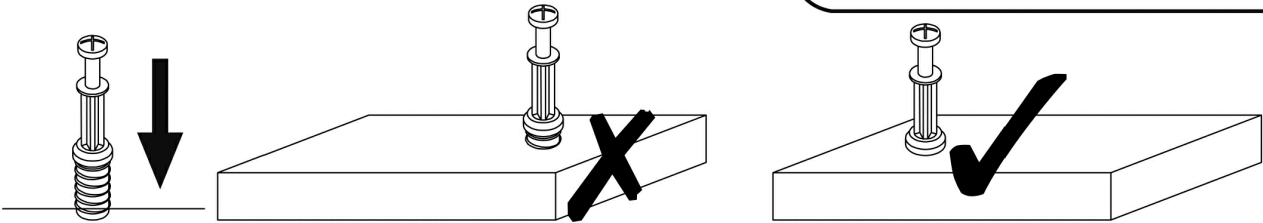

EN_QUICKFIT: Tighten quickfit until shoulder is flush with panel. Do not overtighten or undertighten.

FR_RACCORD RAPIDE: Faites serrer le raccord rapide jusqu'à ce que l'épaulement soit parfaitement encastré dans le panneau. Il ne faut ni trop serrer ni insuffisamment serrer.

ES_QUICKFIT: Apriete quickfit hasta que el hombro se descargue con el panel. NO lo sobreapriete ni lo apriete poco.

DE_QUICKFIT: Ziehen Sie den Quickfit fest, bis die Schulter mit der Platte bündig ist. Bitte nicht zu fest oder zu schwach anziehen.

IT_MONTAGGIO RAPIDO: Stringere il montaggio rapido fino a quando la spalla è a filo con il pannello, non stringere troppo o troppo poco.

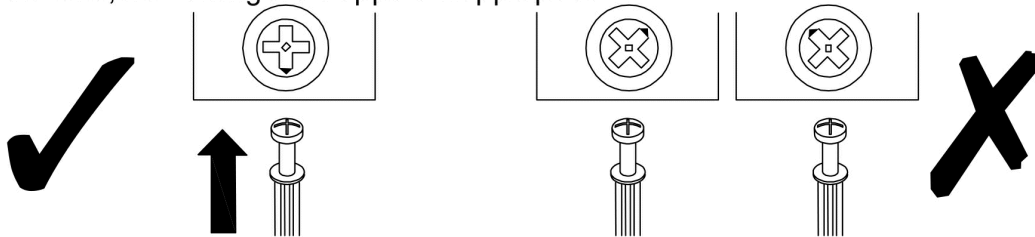

EN_CAM LOCK: When fitting cam lock, ensure starting position is correct before you insert connecting quickfit.

FR_SERRURE BATTEUSE: Avant d'insérer la serrure batteuse, veillez à la bonne orientation avant d'insérer le raccord rapide.

ES_CIERRE DE LA CÁMARA: Cuando instale el cierre de la cámara, asegúrese de que la posición de inicio es correcta antes de que inserte el quickfit conector.

DE_CAM-LOCK: Achten Sie bei der Montage des Cam-Locks auf die richtige Ausgangsposition, bevor Sie den Quickfit einsetzen.

IT_BLOCCAGGIO A CAMMA: Quando si monta il bloccaggio a camma, assicurarsi che la posizione iniziale sia corretta prima di inserire il montaggio rapido di collegamento.

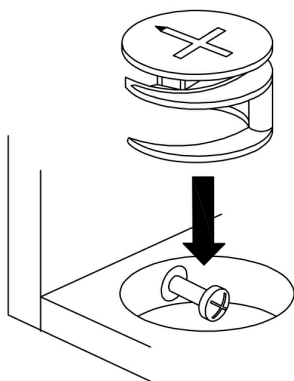

EN_Quickfit head should be in the centre of the cam lock when the two panels are joined.

Cam lock should be inserted before quickfit.

FR_Lorsque les deux panneaux sont assemblés, la tête du raccord rapide doit reposer au centre de la serrure batteuse. Il faut insérer la serrure batteuse avant le raccord rapide.

ES_El cabezal del quickfit debe estar en el centro del cierre de la cámara cuando se unan los dos paneles.

Se debe insertar el cierre de la cámara antes que el quickfit.

DE_Der Quickfit-Kopf sollte sich in der Mitte des Cam-Locks befinden, wenn die beiden Platten zusammengefügt sind.

Der Cam-Lock sollte vor dem Quickfit eingesetzt werden.

IT_La testa del montaggio rapido deve trovarsi al centro del bloccaggio a camma quando i due pannelli sono uniti.

Il Bloccaggio a Camma deve essere inserito prima del montaggio rapido.

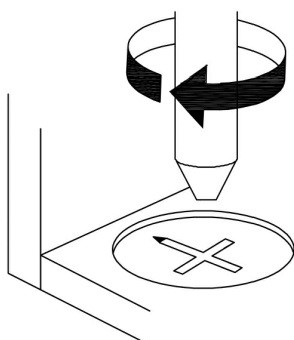

EN_Turn cam lock clockwise to tighten.

FR_Faites tourner la serrure batteuse dans le sens des aiguilles d'une montre pour la resserrer.

ES_Gire el cierre de la cámara en sentido horario para apretarlo.

DE_Drehen Sie den Cam-Lock im Uhrzeigersinn, um ihn festzuziehen.

IT_Ruotare il bloccaggio a camma in senso orario per stringere.

Warnung
1. Die maximale Tragfähigkeit der Produktoberplatte beträgt 60 kg. Überlastung vermeiden.
2. Bitte Kinder nicht auf das Möbel klettern lassen, da dies zu Umkippen und schweren Verletzungen führen kann.
3. Zur Sicherheit bitte die Anweisungen korrekt befolgen und gegebenenfalls professionelle Hilfe in Anspruch nehmen.
4. Das Möbel nicht in der Nähe von Hitzequellen oder heißen Gegenständen platzieren, um Brandgefahr zu vermeiden.
5. Das Möbel nicht in feuchten Umgebungen aufstellen, um Schäden am Material zu vermeiden.
6. Regelmäßige Überprüfung aller Verbindungsstücke und Befestigungen, um sicherzustellen, dass sie fest sitzen und unerwartete Unfälle zu verhindern.
7. Das Produkt ist mit einem Kippschutz ausgestattet, um Verletzungen durch Umkippen zu verhindern.

Warning
1 The maximum load-bearing capacity of the product top panel is 60 kg. Do not overload.
2 Please do not allow children to climb on furniture, as this may result in tipping and serious injuries.
3 For safety, please follow the instructions correctly and seek professional assistance if necessary.
4 Do not place furniture near heat sources or hot items to avoid the risk of fire.
5 Do not place furniture in damp environments to prevent material damage.
6 Regularly check all fittings and fastenings to ensure they are secure and to prevent accidents.
7 This product comes with an anti-tip device to prevent injuries from tipping.

Avertissement
1 La capacité de charge maximale du plateau supérieur du produit est de 60 kg. Ne pas surcharger.
2 Veuillez ne pas laisser les enfants grimper sur les meubles, car cela peut entraîner un basculement et des blessures.
3 Pour des raisons de sécurité, veuillez suivre correctement les instructions et demander de l'aide professionnelle si nécessaire.
4 Ne pas placer les meubles près de sources de chaleur ou d'objets chauds pour éviter tout risque d'incendie.
5 Ne pas placer les meubles dans des environnements humides pour éviter les dommages matériels.
6 Vérifiez régulièrement tous les raccords et fixations pour vous assurer qu'ils sont bien serrés et pour éviter les accidents.
7 Ce produit est équipé d'un dispositif anti-basculement pour éviter les blessures en cas de basculement.

Avviso
1 La capacità massima di carico del piano superiore del prodotto è di 60 kg. Non sovraccaricare.
2 Si prega di non permettere ai bambini di arrampicarsi sui mobili, poiché ciò potrebbe causare il ribaltamento e gravi lesioni.
3 Per motivi di sicurezza, seguire correttamente le istruzioni e richiedere assistenza professionale se necessario.
4 Non posizionare i mobili vicino a fonti di calore o oggetti caldi per evitare il rischio di incendio.
5 Non posizionare i mobili in ambienti umidi per evitare danni al materiale.
6 Controllare regolarmente tutti i raccordi e i fissaggi per assicurarsi che siano saldi e per evitare incidenti.
7 Questo prodotto è dotato di un dispositivo anti-ribaltamento per evitare lesioni dovute al ribaltamento.

Aviso
1 La capacidad máxima de carga del panel superior del producto es de 60 kg. No sobrecargar.
2 Por favor, no permita que los niños trepen sobre los muebles, ya que esto podría provocar que se vuelquen y causar lesiones graves.
3 Por seguridad, siga correctamente las instrucciones y solicite ayuda profesional si es necesario.
4 No coloque los muebles cerca de fuentes de calor o objetos calientes para evitar el riesgo de incendio.
5 No coloque los muebles en entornos húmedos para evitar daños en el material.
6 Revise regularmente todas las conexiones y sujeciones para asegurarse de que estén firmes y para evitar accidentes.
7 Este producto viene con un dispositivo antivuelco para evitar lesiones por vuelco.

·Components - fittings

Please check you have all the panels listed below.

Note: The quantitie below are the correct amount to complete the assembly. In some cases more fittings may be supplied than are required.

·Komponenten Verschraubungen

Bitte überprüfen Sie, ob Sie alle unten aufgeführten Panels haben.







Hinweis: Die folgende Menge ist die richtige Menge, um die Montage abzuschließen. In einigen Fällen können mehr Armaturen geliefert werden, als erforderlich.

·Composants - accessoires

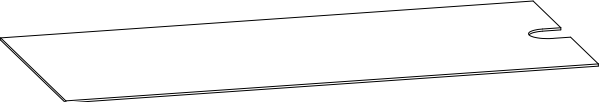
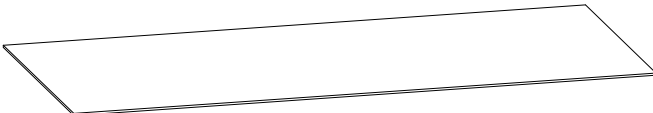
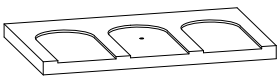





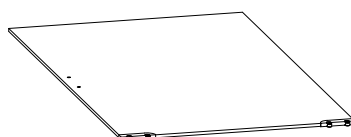



Veillez vérifier que vous possédez tous les panneaux énumérés ci - dessous.

Remarque: les quantités ci - dessous sont les quantités correspondantes nécessaires pour terminer l'assemblage. Dans certains cas, plus d'accessoires que nécessaire peuvent être fournis.

N620P191602 - Box:1/2

			
⑨ x 2pcs		⑩ x 2pcs	
			
⑪ x 2pcs	⑫ x 2pcs	⑬ x 2pcs	⑭ x 2pcs
			
⑮ x 2pcs	⑯ x 2pcs	⑰ x 2pcs	

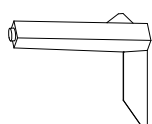
N620P191603 - Box:2/2

			
① x 1pc		② x 1pc	
			
③ x 1pc	④ x 1pc	⑤ x 1pc	⑥ x 1pc
			
⑦ x 1pc	⑧ x 2pcs	⑱ x 4pcs	⑲ x 1pc

·Components - fittings

Please check you have all the panels listed below.

Note: The quantitie below are the correct amount to complete the assembly. In some cases more fittings may be supplied than are required.

·Komponenten Verschraubungen

Bitte überprüfen Sie, ob Sie alle unten aufgeführten Panels haben.











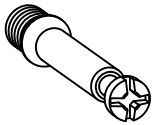

Hinweis: Die folgende Menge ist die richtige Menge, um die Montage abzuschließen. In einigen Fällen können mehr Armaturen geliefert werden, als erforderlich.

·Composants - accessoires

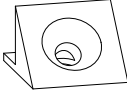

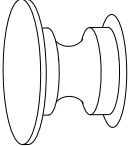
Veuillez vérifier que vous possédez tous les panneaux énumérés ci - dessous.

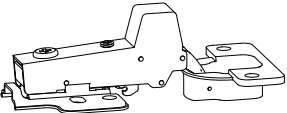

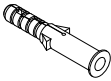

Remarque: les quantités ci - dessous sont les quantités correspondantes nécessaires pour terminer l'assemblage. Dans certains cas, plus d'accessoires que nécessaire peuvent être fournis.

Hardware-Liste :N620P191603 - Box:2/2

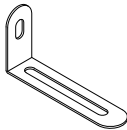
 M6x35mm	 Φ15x9mm	 Φ8x30mm	 M3x12mm
A x 36pcs	B x 36pcs	C x 28pcs	D x 16pcs
	 M4x14mm		 M4x25mm
E x 4pcs	F x 44pcs	G x 8pcs	H x 8pcs
	 M4x18mm	 M3x16mm	
I x 4pcs	J x 8pcs	K x 8pcs	P x 4pcs
			
Q x 2pcs	R x 1pc		

Prevent dumping of spare parts+ N620P175378 - Box:1/2

	 M4x35mm	 M4x16mm	
L x 2pcs	M x 2pcs	N x 2pcs	O x 2pcs

 M3x12mm	 M4x14mm	 M4x25mm	 M4x16mm
D x 16pcs	F x 44pcs	H x 8pcs	N x 2pcs
 M3x16mm			
K x 8pcs			

DE:Bitte beachten Sie, dass die Formen der Schrauben D und F und H und N und K ähnlich sind. Bitte installieren Sie entsprechend der Anleitung und unterscheiden Sie sie!

UK:Please note that the shapes of screws D and F and H and N and K are similar. Please install according to the instructions and distinguish them!

FR:Notez que les vis D et F et H et N et K ont des formes similaires. Veuillez les installer en suivant les instructions pour les séparer!

Installationsanleitung/Installation Instruction/Instruction d'installation

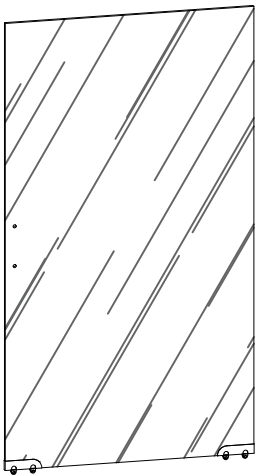
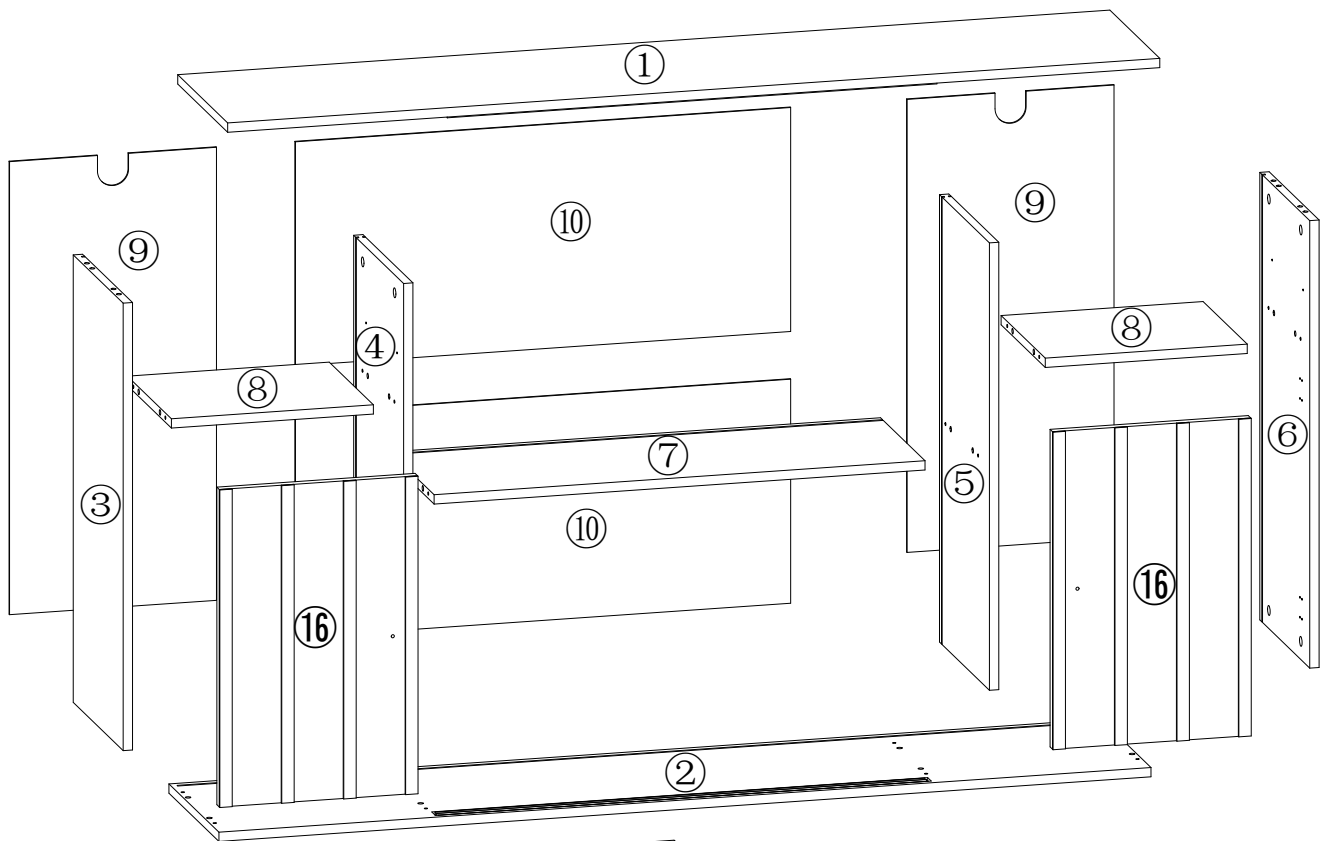

17

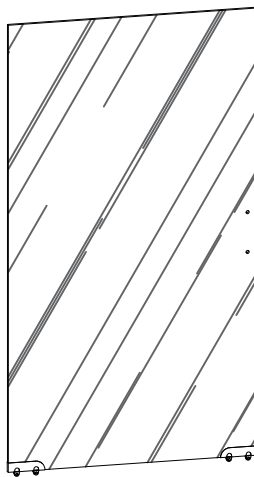

17

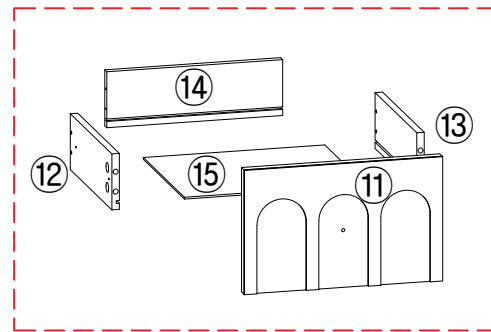

x2pcs

Importeur	Decobus Handel GmbH		
Adresse	Innungsstraße 9, 21244 Buchholz, Deutschland		
URL	https://www.decobusgroup.de		
Hersteller	SILVER UNION INVESTMENTS LIMITED		
Adresse	PORTCULLIS CHAMBERS, P.O. BOX 1225, APIA, SAMOA		
Email/URL	372726447@QQ.COM		
<table border="1"> <tr> <td>EC</td> <td>REP</td> </tr> </table>	EC	REP	Decobus Handel GmbH
	EC	REP	
	Innungsstraße 9, 21244 Buchholz, Deutschland		
https://www.decobusgroup.de			

Installationsanleitung/Installation Instruction/Instruction d'installation



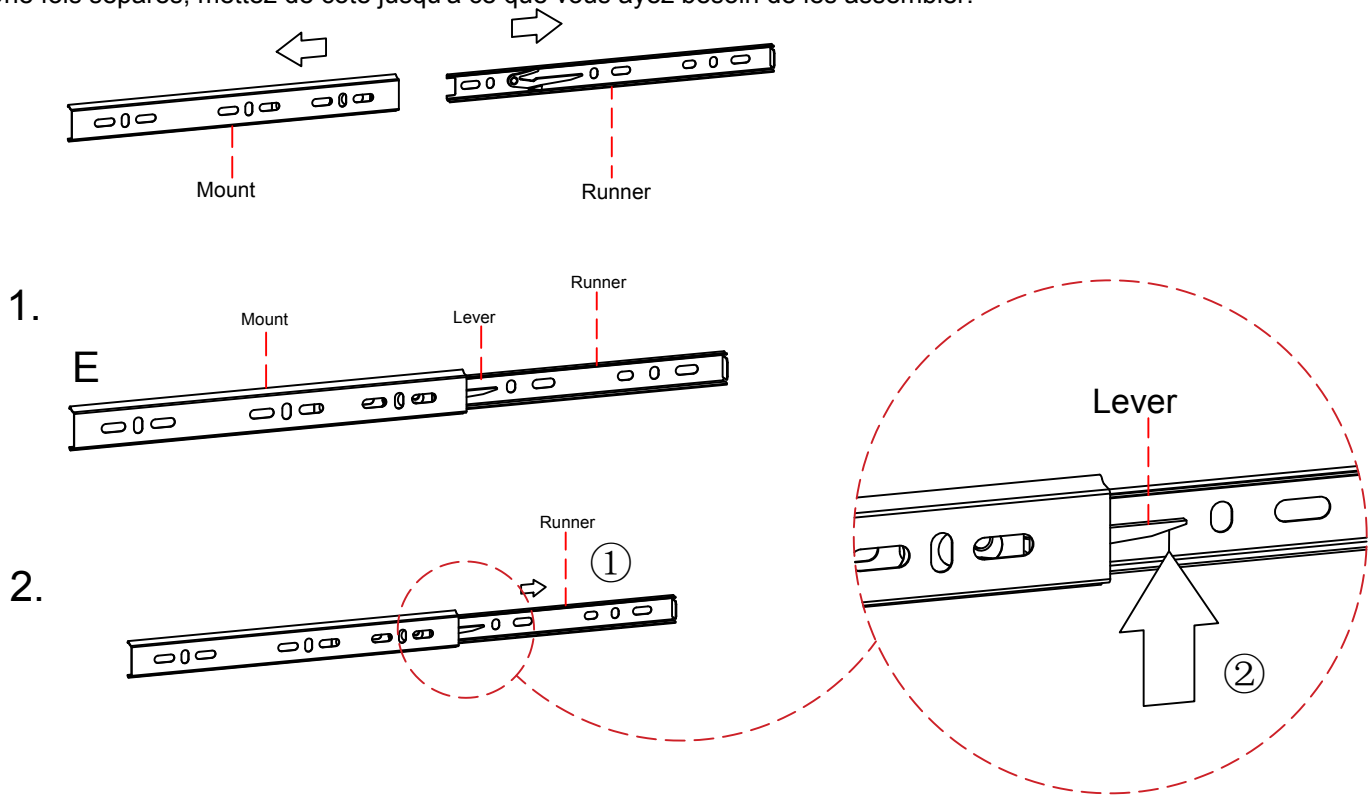

STEP 1/SCHRITT 1/Étapes 1

- Slides Must Be Separated Before Assembly.
- After Separated, Set Aside Until Needed for Assembly.
- Folien müssen vor der Montage getrennt werden.
- Nach der Trennung beiseite stellen, bis zur Montage benötigt wird.
- Les diapositives doivent être séparées avant l'assemblage.
- Une fois séparés, mettez de côté jusqu'à ce que vous ayez besoin de les assembler.

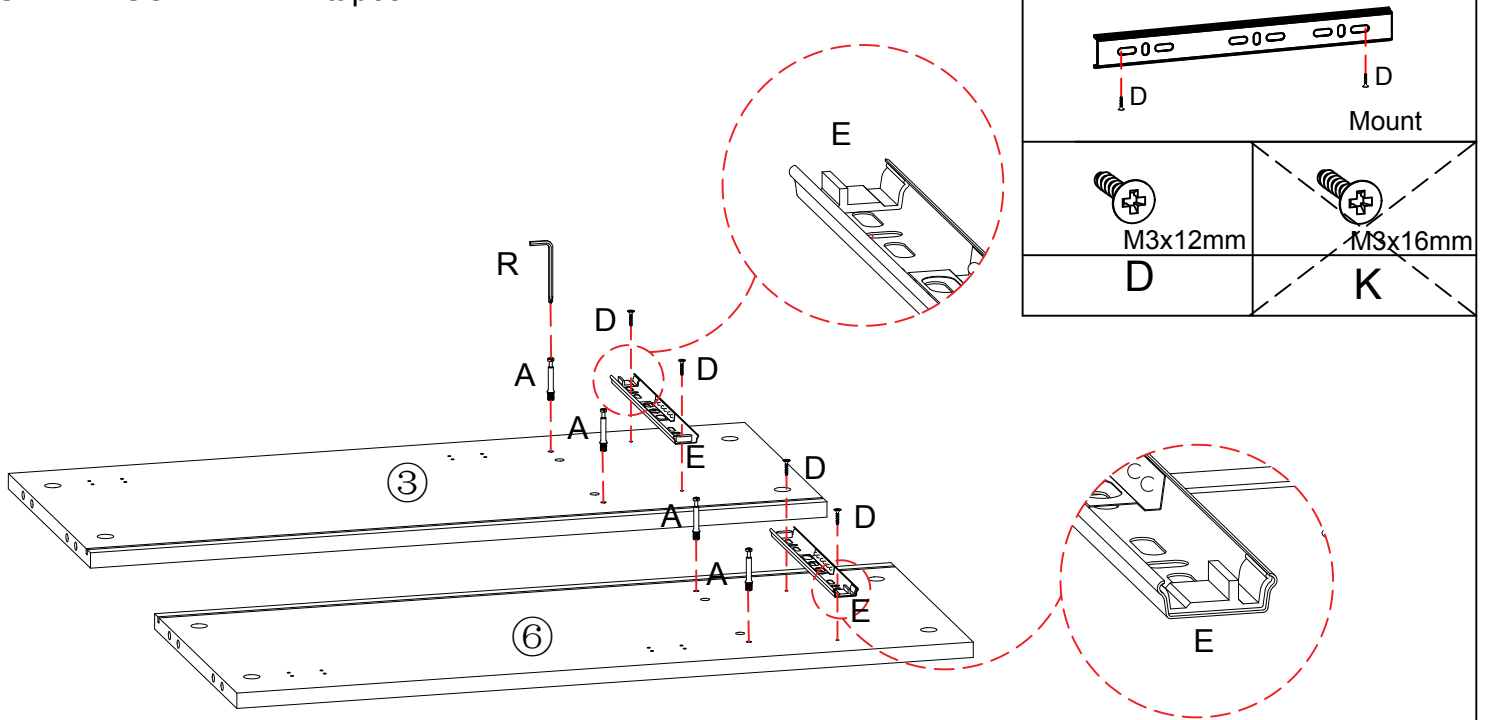

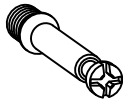
STEP 2/SCHRITT 2/Étapes 2



			
A x 4pcs	E x 2pcs	D x 4pcs	R x 1pc

Installationsanleitung/Installation Instruction/Instruction d'installation

STEP 3/SCHRITT 3/Étapes 3

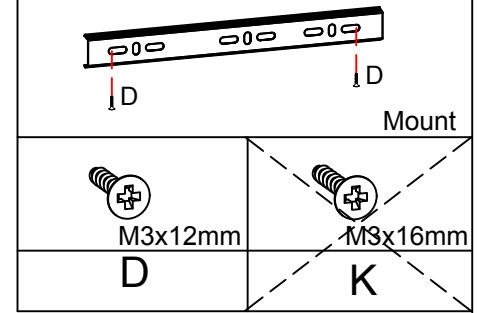
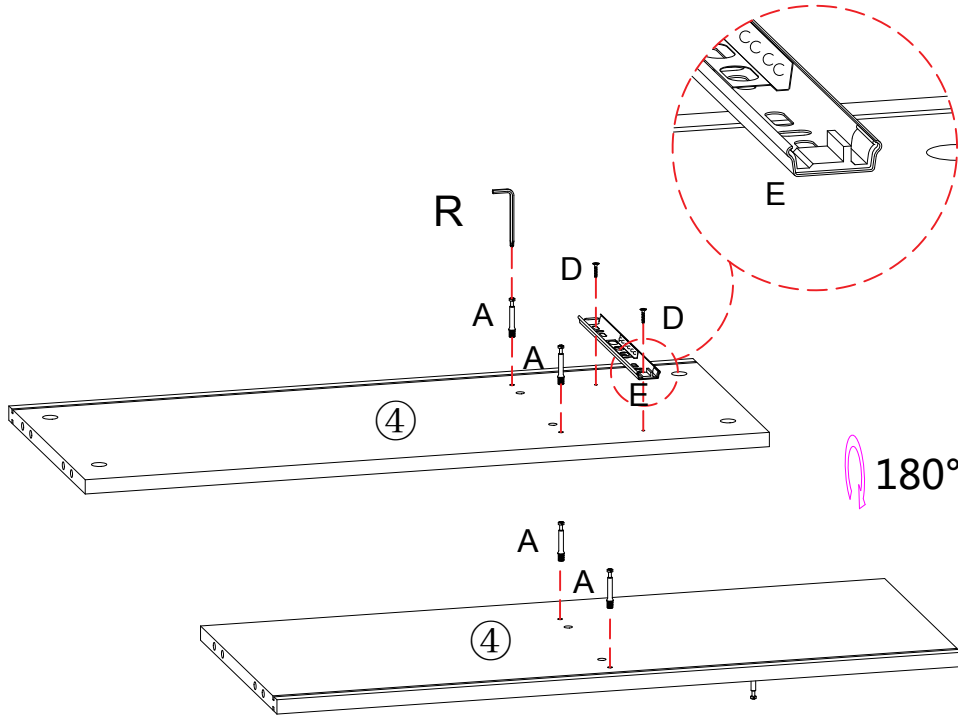

A x 4pcs	E x 1pc	D x 2pcs	R x 1pc

STEP 4/SCHRITT 4/Étapes 4

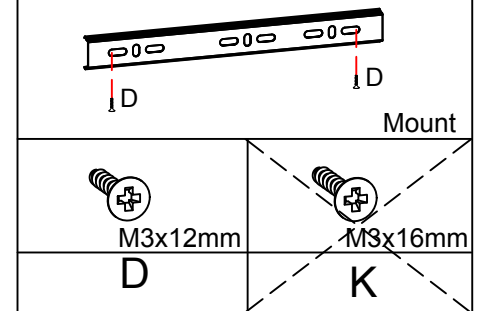
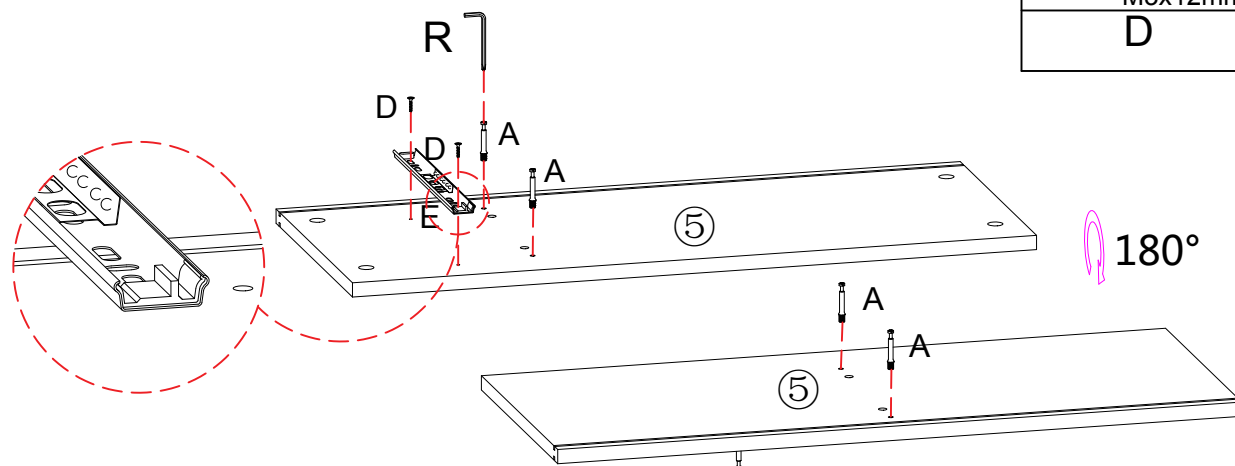



A x 4pcs	E x 1pc	D x 2pcs	R x 1pc

Installationsanleitung/Installation Instruction/Instruction d'installation

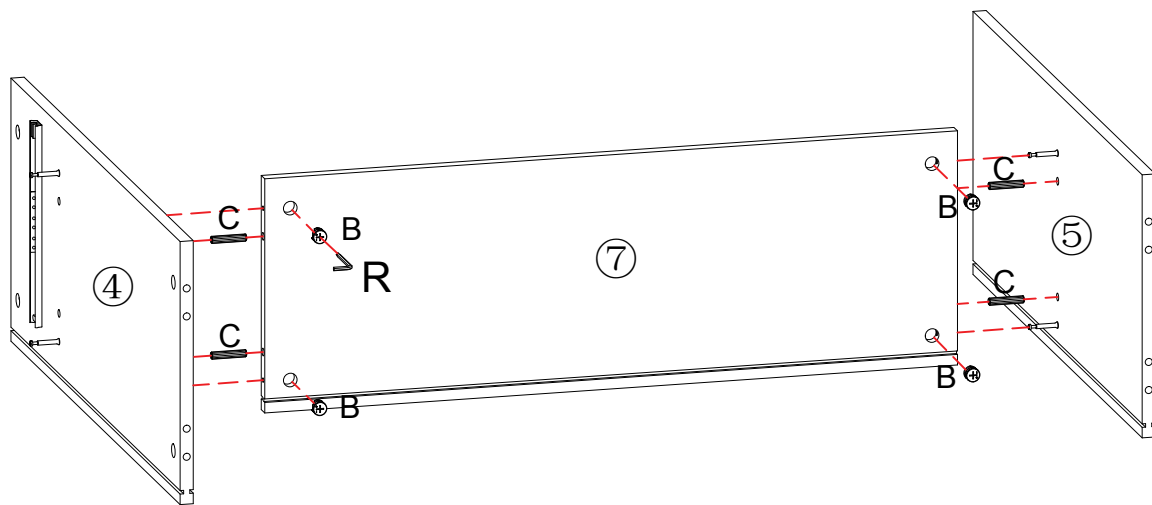

STEP 5/SCHRITT 5/Étapes 5

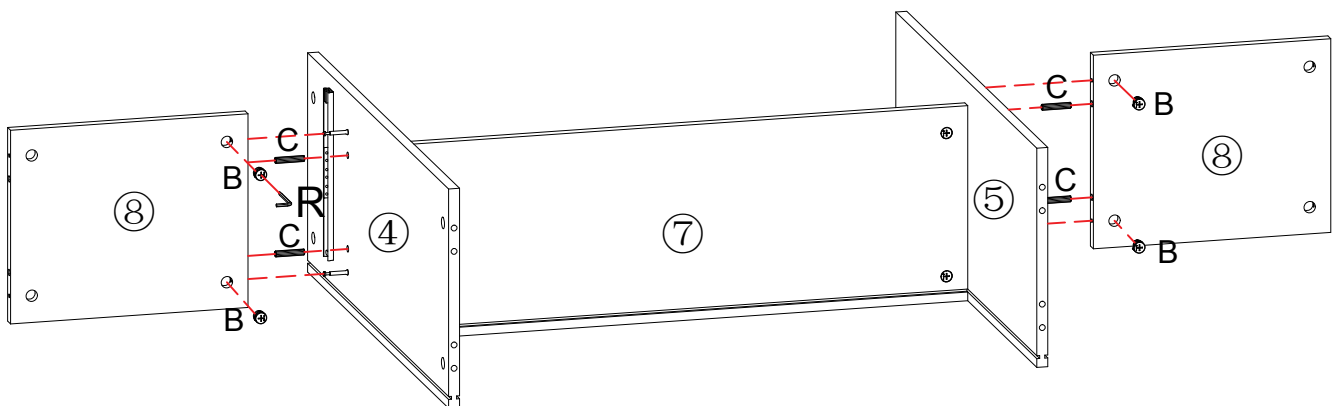

		
B x4pcs	C x 4pcs	Rx1pc

STEP 6/SCHRITT 6/Étapes 6





		
B x4pcs	C x 4pcs	R x1pc

Installationsanleitung/Installation Instruction/Instruction d'installation

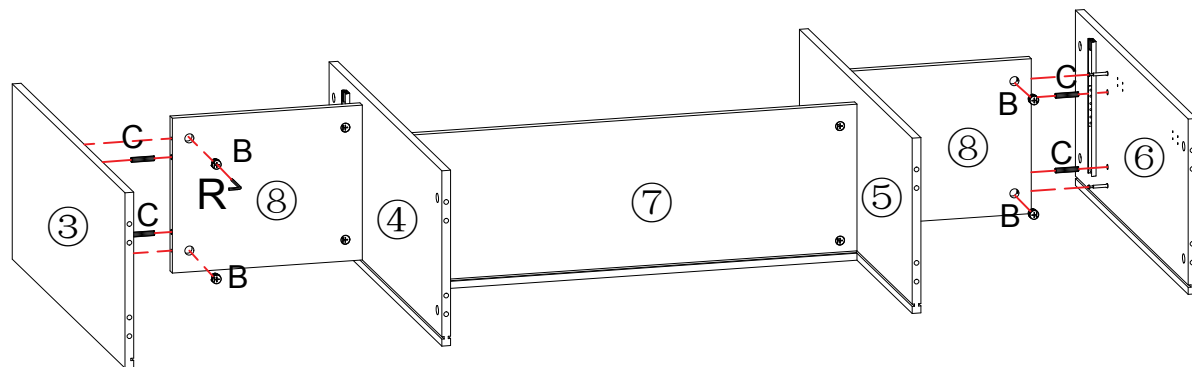
STEP 7/SCHRITT 7/Étapes 7



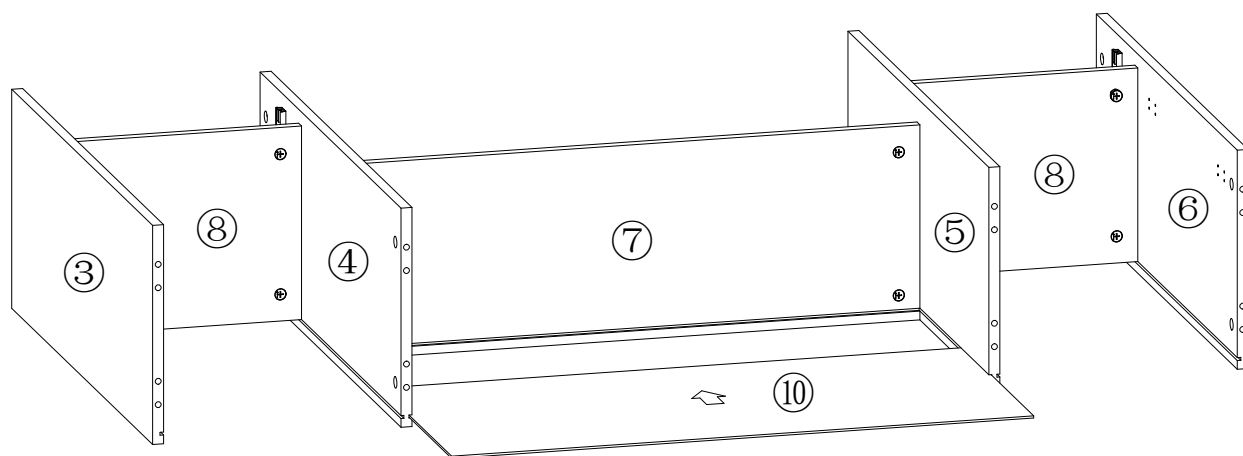

		
B x4pcs	C x 4pcs	R x1pc

STEP 8/SCHRITT 8/Étapes 8





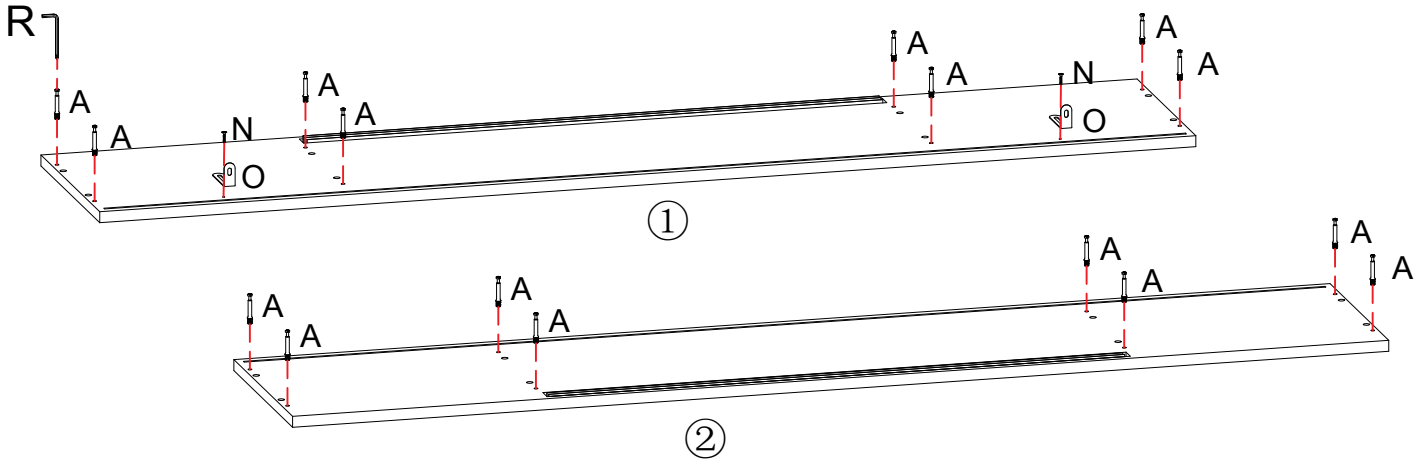

Installationsanleitung/Installation Instruction/Instruction d'installation

STEP 9/SCHRITT 9/Étapes 9

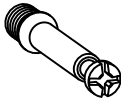

 M4x16mm	 M4x14mm
N	F



	 M4x16mm		
A x 16pcs	N x 2pcs	O x 2pcs	R x 1pc

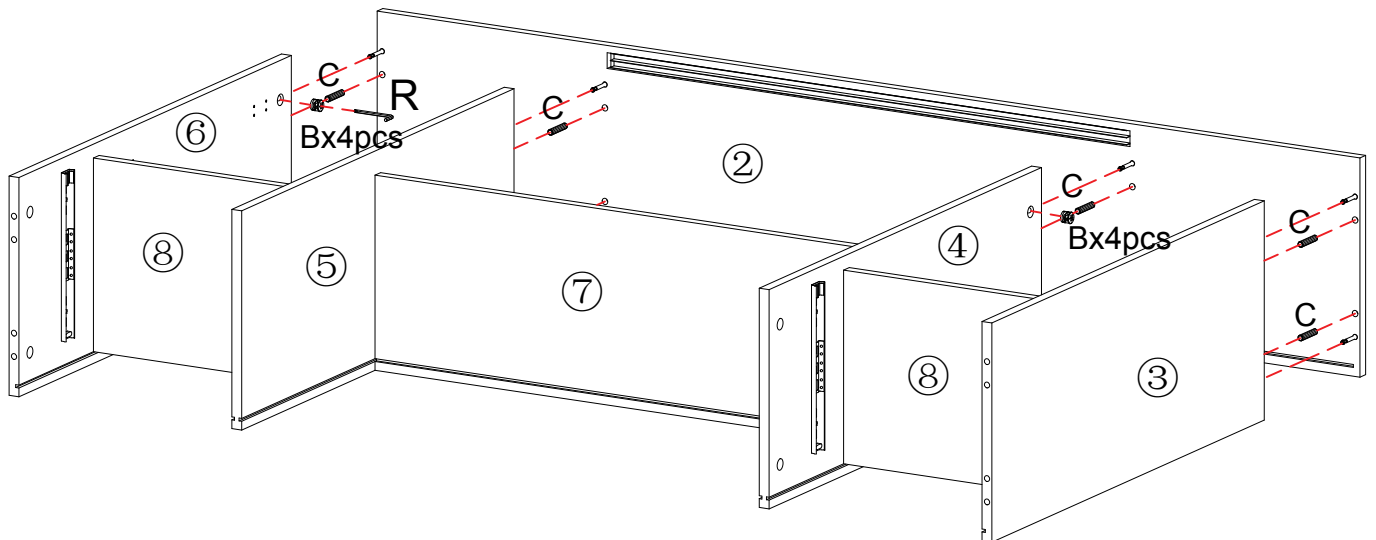

STEP 10/SCHRITT 10/Étapes 10





		
B x 8pcs	C x 8pcs	R x 1pc

Installationsanleitung/Installation Instruction/Instruction d'installation

STEP 11/SCHRITT 11/Étapes 11

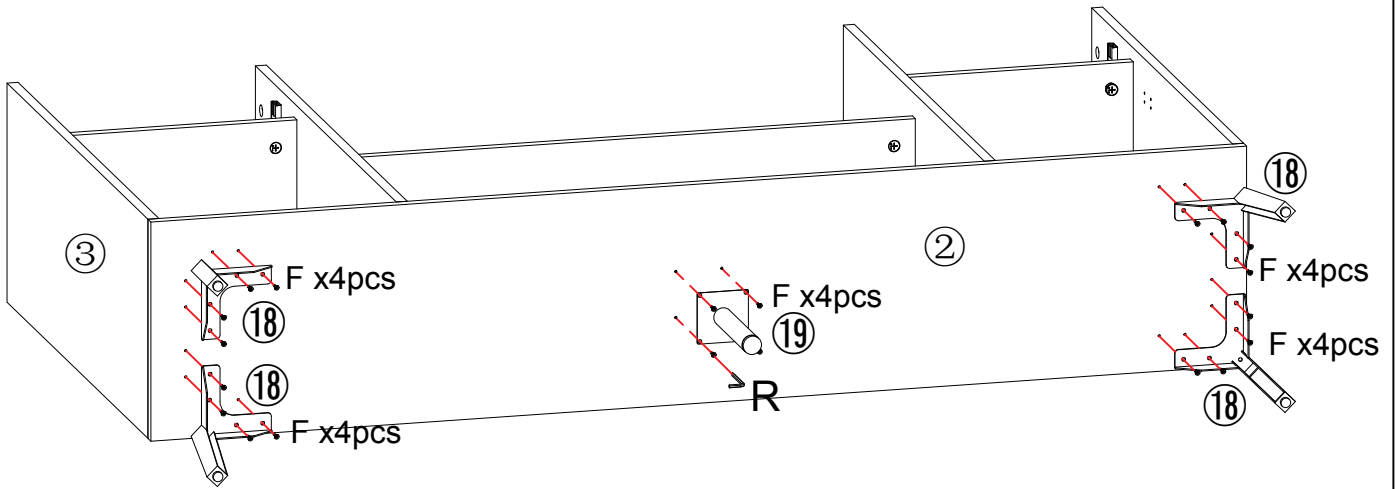
 M4x14mm	 M4x16mm
F	N



 M4x14mm	
F x 20pcs	R x1pc

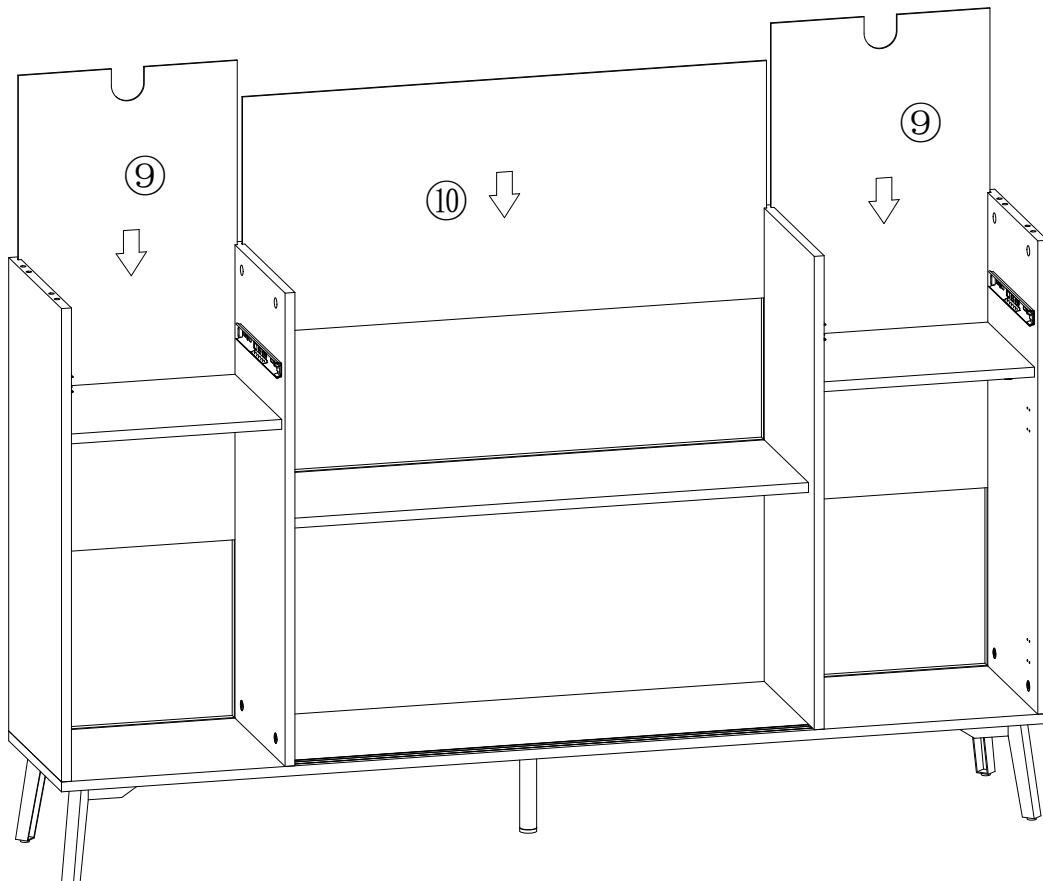

STEP 12/SCHRITT 12/Étapes 12



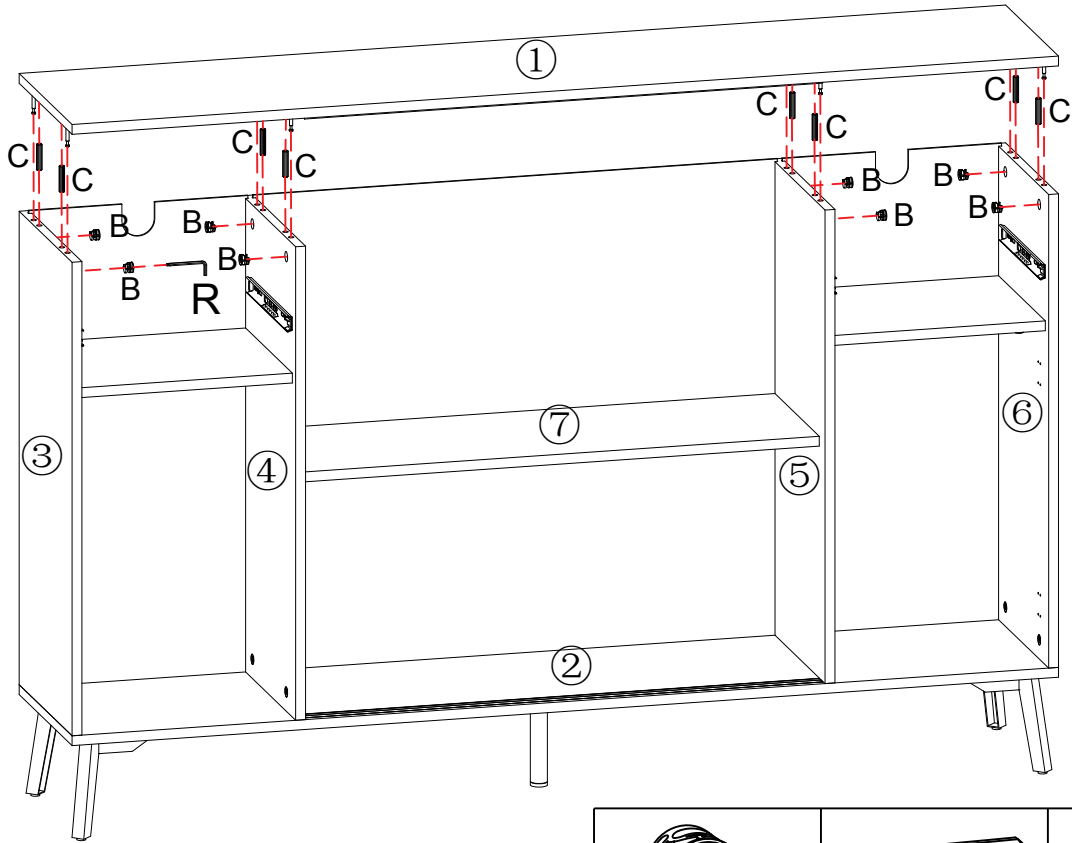

Installationsanleitung/Installation Instruction/Instruction d'installation

STEP 13/SCHRITT 13/Étapes 13





		
B x 8 pcs	C x 8 pcs	R x 1 pc

STEP 14/SCHRITT 14/Étapes 14

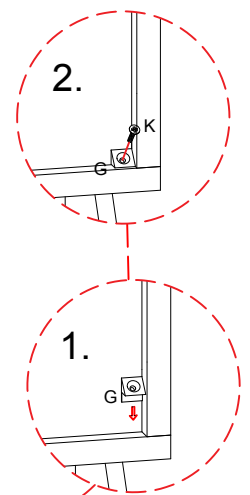
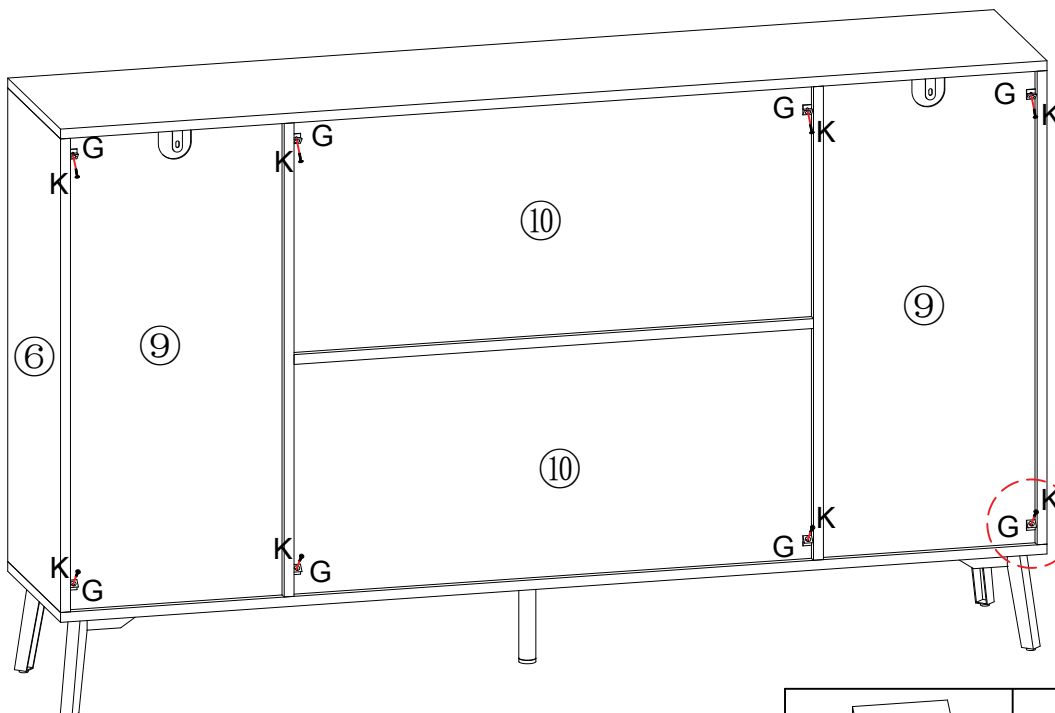
 M3x12mm D	 M3x16mm K
--	---



		
G x 8 pcs	K x 8 pcs	J x 1 pc

Installationsanleitung/Installation Instruction/Instruction d'installation

STEP 15/SCHRITT 15/Étapes 15

Installation instruction for Anti-tipping



Installationsanleitung zum Kippen

Instructions d'installation du dispositif anti - basculement

Prevent dumping of spare parts

Vermeidung des Dumpings von Ersatzteilen

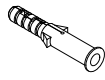
Prévention du déversement de pièces détachées

	
L x 2pcs	M4x35mm M x 2pcs

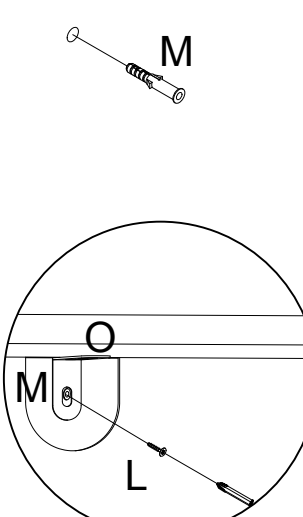

M

To prevent children from climbing and dumping parts, first move the cabinet to the wall, then use pen to make hole in the wall of O parts, remove the cabinet and punch holes in the marked position with M6 drill, then punch M into the hole, then move the cabinet to its original position and secure it with Screw L.

Um zu verhindern, dass Kinder klettern und Teile kippen, bewegen Sie zuerst den Schrank an die Wand, dann verwenden Sie Stift, um Loch in die Wand von O-Teilen zu machen, entfernen Sie den Schrank und stanzen Löcher in der markierten Position mit M6-Bohrer, dann stanzen M in das Loch, dann bewegen Sie den Schrank in seine ursprüngliche Position und sichern Sie es mit Schraube L.

Pour empêcher les enfants de grimper et de verser des pièces, déplacez d'abord l'armoire sur le mur, puis percez le mur de la pièce O avec un stylo, retirez l'armoire, percez dans la position marquée avec un foret M6, puis enfoncez M dans le trou, puis déplacez l'armoire dans sa position d'origine, fixez - la avec une vis L.

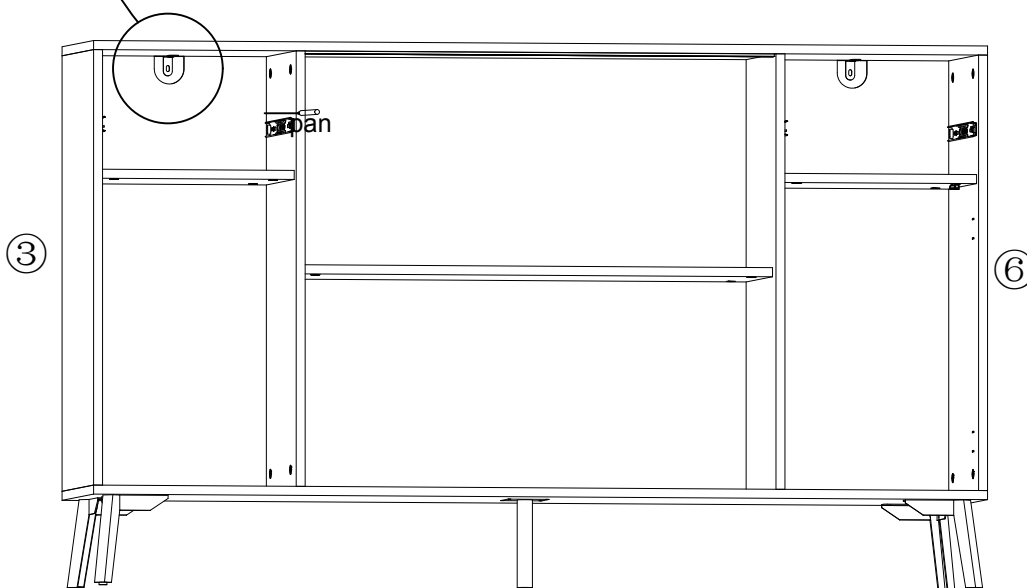





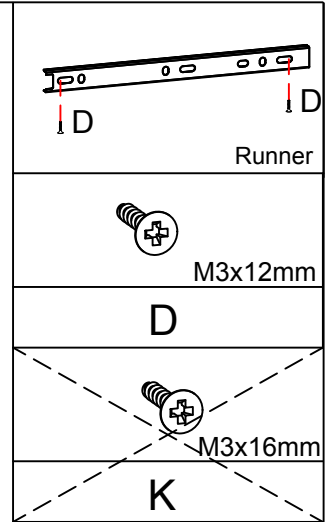
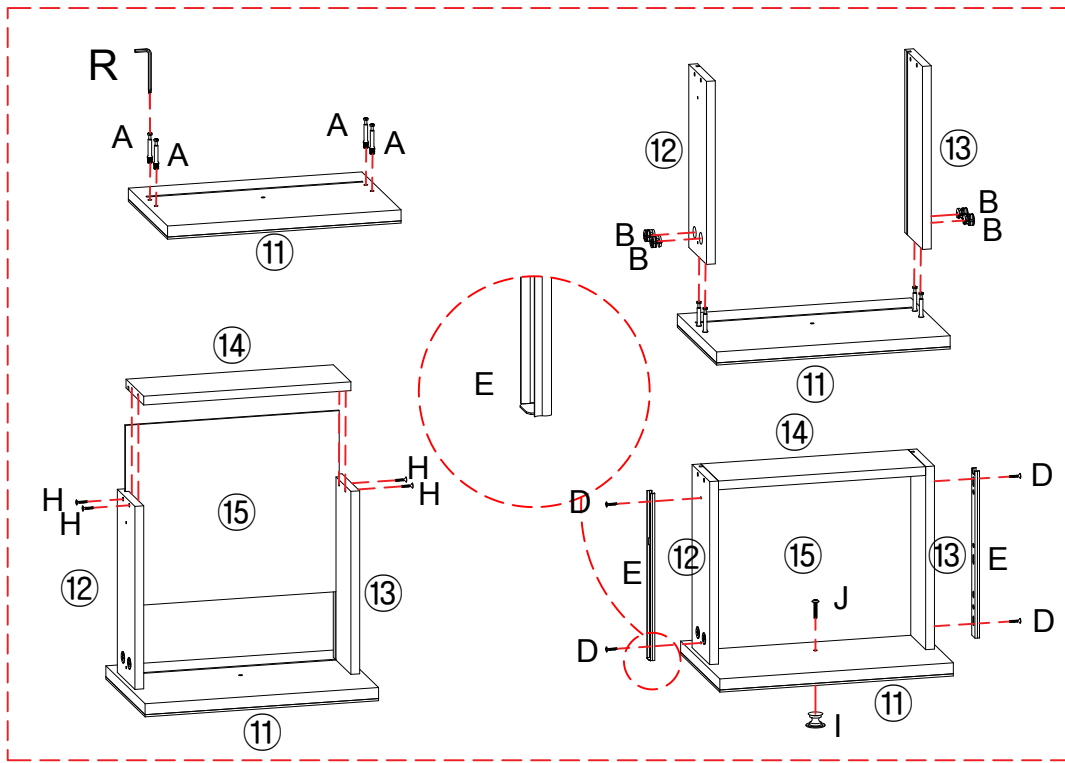

Installationsanleitung/Installation Instruction/Instruction d'installation

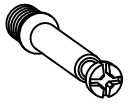
STEP 16/SCHRITT 16/Étapes 16

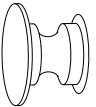

x2pcs

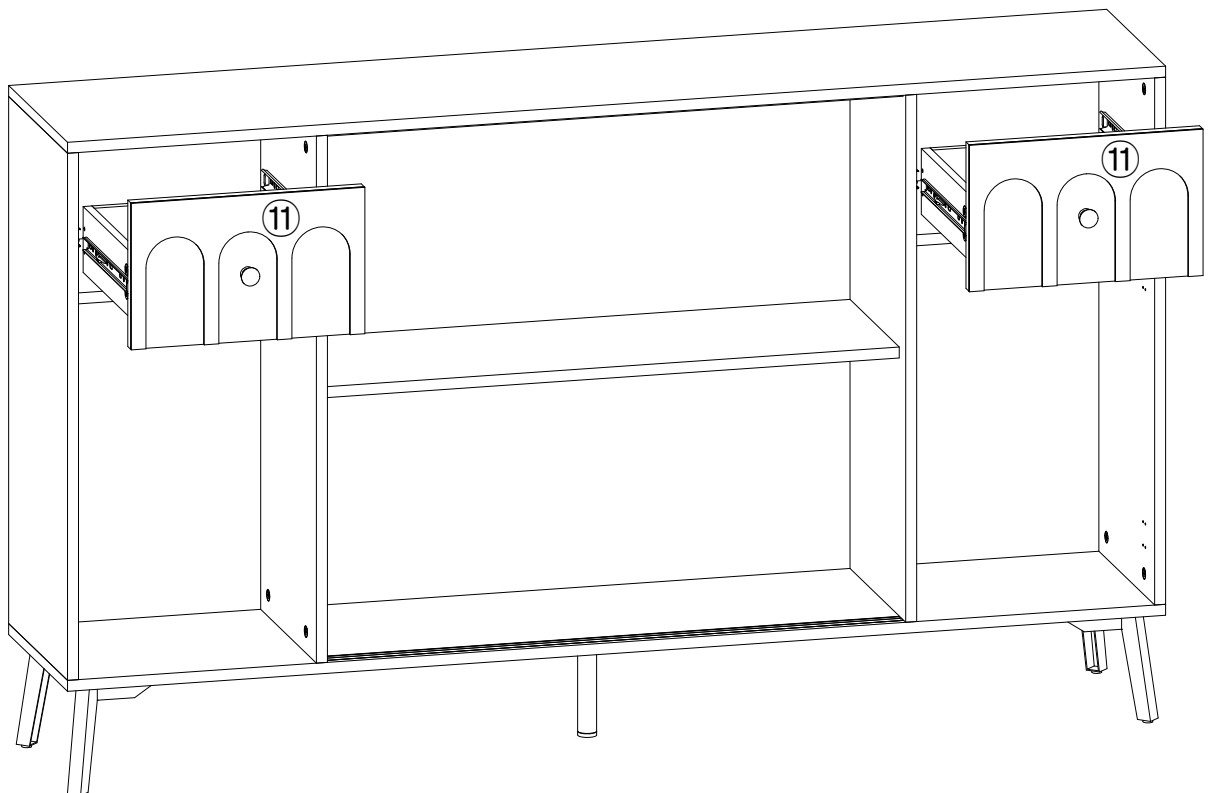

							
A x 8pcs	B x 8pcs	D x 8pcs	Runner	H x 8pcs	I x 2pcs	J x 2pcs	T x 1pc

STEP 17/SCHRITT 17/Étapes 17





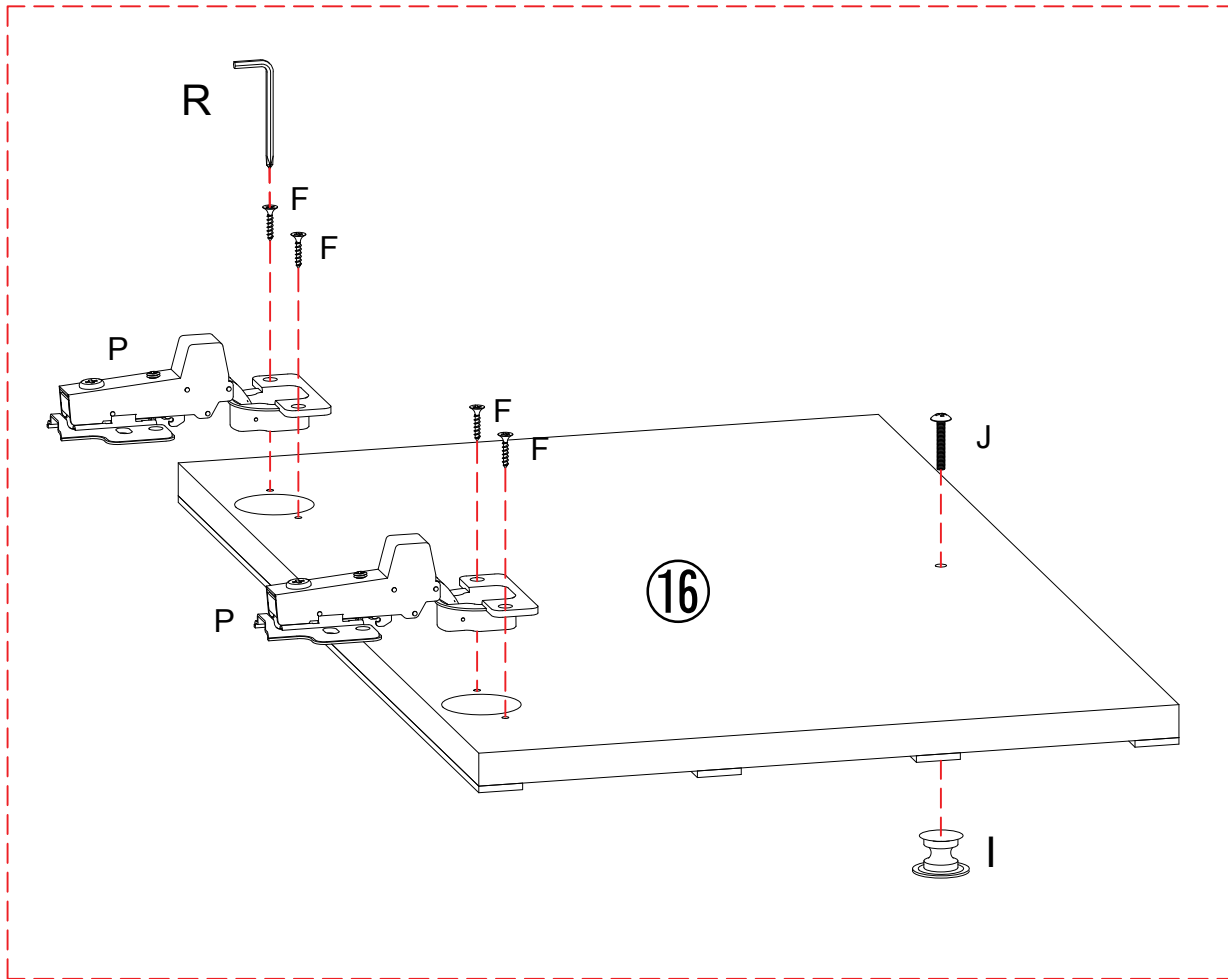

Installationsanleitung/Installation Instruction/Instruction d'installation

STEP 18/SCHRITT 18/Étapes 18

 M4x14mm	 M3x16mm
F	K

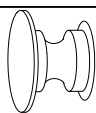

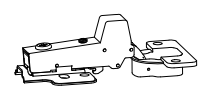

x2pcs

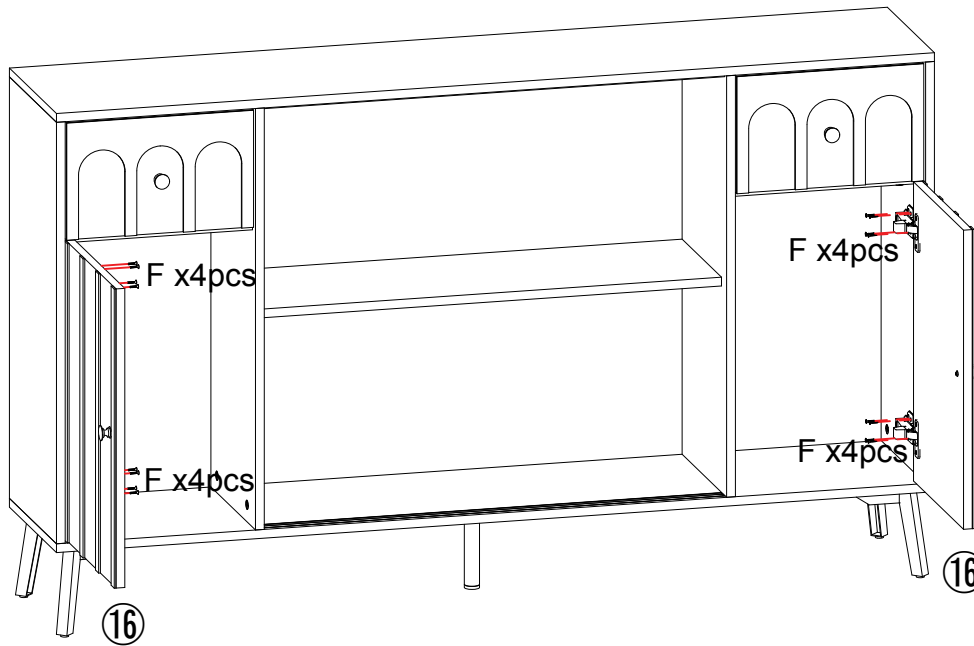

 M4x14mm		 M4x18mm		
F x 8pcs	I x 2pcs	J x 2pcs	P x 4pcs	J x 1pc

Installationsanleitung/Installation Instruction/Instruction d'installation

STEP 19/SCHRITT 19/Étapes 19



 M4x14mm	
F x 16pcs	J x1pc

 M4x14mm	 M3x16mm
F	K

- When the hinges are installed, you can refer to the pictures to adjust crevice of the doors till it's perfect:
- Wenn die Scharniere installiert sind, können Sie sich die Bilder ansehen, um den Spalt der Türen anzupassen, bis es perfekt ist:
- Lorsque la charnière est installée, vous pouvez vous référer à l'image pour ajuster la fente de la porte jusqu'à ce qu'elle soit parfaite:

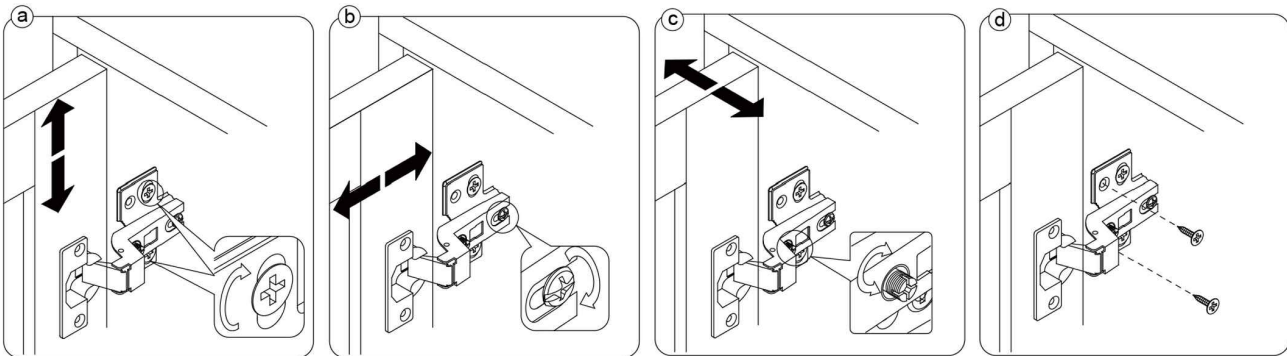



1. To adjust the doors up and down, please refer to step (a)
 2. To adjust the distance between the doors and side panels, please refer to step (b)
 3. To adjust the gap between two doors, please refer to step (c)
 4. After the adjustment finished, please tight the screws, refer to step (d)
1. Um die Türen nach oben und unten einzustellen, siehe Schritt (a)
 2. Um den Abstand zwischen den Türen und den Seitenwänden einzustellen, lesen Sie bitte Schritt (b)
 3. Um den Abstand zwischen zwei Türen einzustellen, siehe Schritt (c)
 4. Nachdem die Einstellung beendet ist, ziehen Sie bitte die Schrauben fest, siehe Schritt (d)
1. Pour régler les portes de haut en bas, reportez - vous à l'étape (A)
 2. Pour régler la distance entre la porte et le panneau latéral, reportez - vous à l'étape b)
 3. Pour régler l'écart entre les deux portes, reportez - vous à l'étape (c)
 4. Une fois le réglage terminé, serrez les vis, voir étape (d)

Installationsanleitung/Installation Instruction/Instruction d'installation

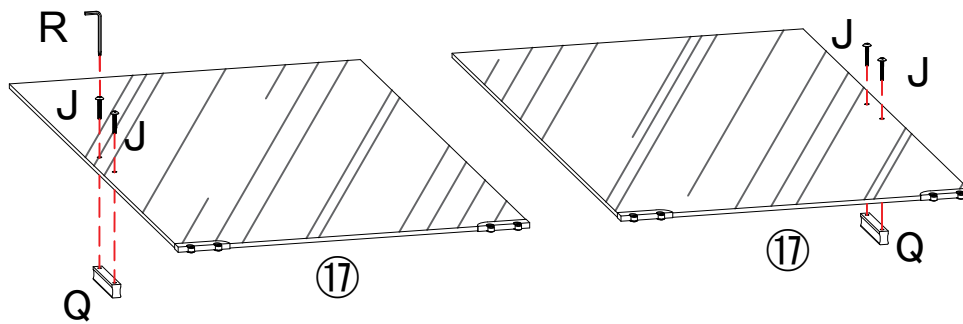
STEP 20/SCHRITT 20/Étapes 20

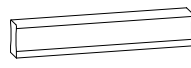

 M4x18mm		
J x4pcs	Q x 2pcs	J x1pc

STEP 21/SCHRITT 21/Étapes 21

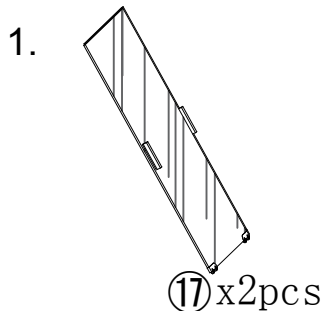

- The two glass doors are stacked in the picture.
- Die beiden Glastüren sind im Bild gestapelt.
- Les deux portes vitrées sont Empilés dans l'image.

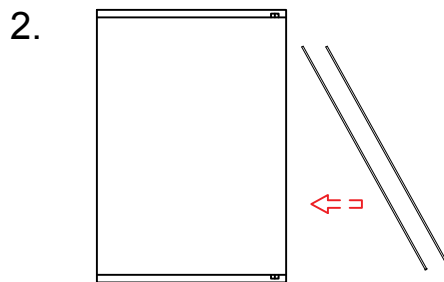

- Put the two pieces in the cabinet diagonally.
- Legen Sie die beiden Stücke in die Schrägstrich.
- Mettez ces deux morceaux dedans Armoire oblique.

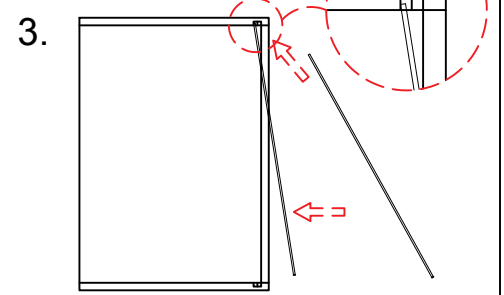

- Need a helper to hole the inner piece, insert the outer piece glass into the first card slot in front of the panel, and move the bottom outwards into the first card slot in the bottom plate.
- Benötigen Sie einen Helfer, um das innere Stück zu lochen, fügen Sie das äußeres Stück Glas in den ersten Kartenschlitz vor dem und bewegen Sie die Unterseite nach außen in die Erster Kartenschlitz in der unteren Platte.
- besoin d'un assistant pour percer l'intérieur, insérer Insert de verre de feuille extérieure dans la première fente de carte à l'avant Panneau, et déplacez le bas vers l'extérieur jusqu'à Le premier emplacement de carte sur la plaque de base.

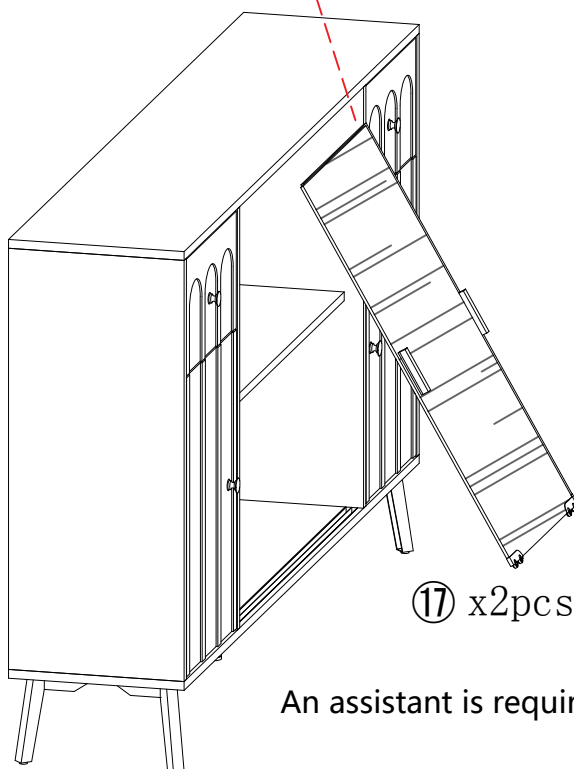

An assistant is required.

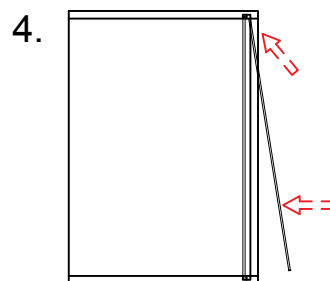

- Insert the inner piece of glass into the second slot in the same way.
- Setzen Sie das innere Stück Glas in der zweite Platz in gleicher Weise.
- insérer le vitrage intérieur La deuxième fente est de la même manière.

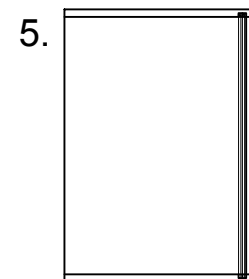

- Clamp into the slot as shown.
- Klemmen Sie wie gezeigt in den Schlitz.
- encliqueter dans la fente comme le montre l'image.