

MONTAGEANLEITUNG

Artikelnummer: WF319112WAA
WF319113WAA
WF319114WAA
WF319115WAA

Dieses Set ist in 4 Boxen enthalten. Wenn Sie keine vollen 4 Boxen erhalten wenden Sie sich bitte an unseren Kundenservice.

This set comes in 4 boxes. If you do not receive a full 4 boxes, please contact our customer service.

Etagenbett 200x140/90cm

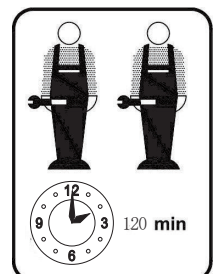
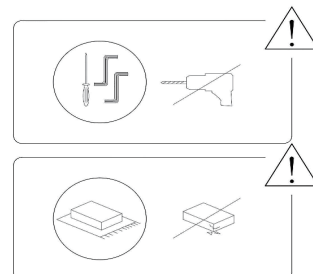
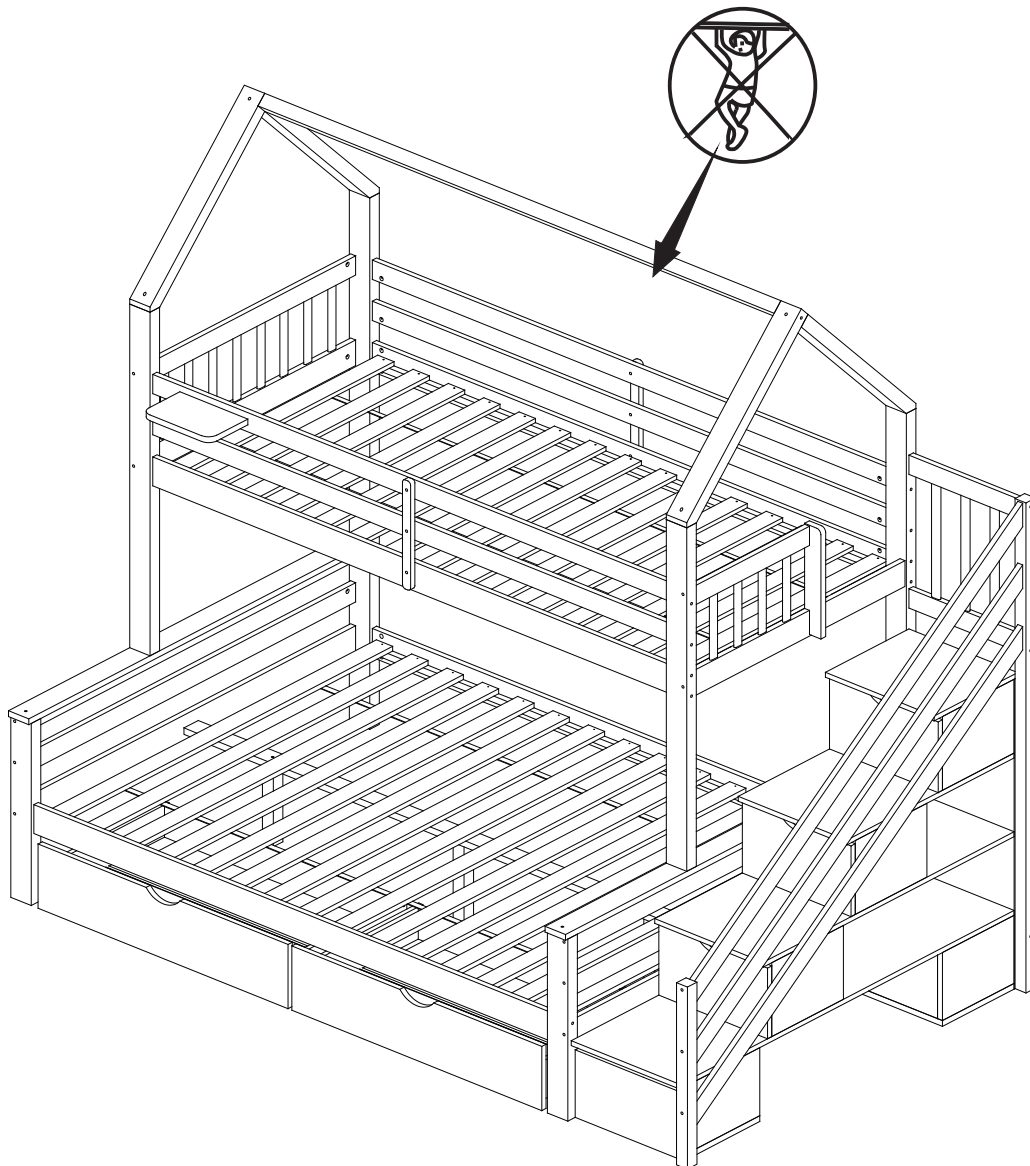

INSTRUCTIONS

IMPORTANT-READ CAREFULLY-RETAIN FOR FUTURE REFERENCE

- a) **WARNING**-High beds and the upper bed of bunk beds are not suitable for children under six years due to the risk of injury from falls;
- b) **WARNING**-Bunk beds and high beds can present a serious risk of injury from strangulation if not used correctly. Never attach or hang items to any part of the bunk bed that are not designed to be used with the bed, for example, but not limited to ropes, strings, cords, hooks, belts and bags.
- c) **WARNING** -Children can become trapped between the bed and the wall, a roof pitch, the ceiling adjoining pieces of furniture (e.g. cupboards) and the like. To avoid risk of serious injury the distance between the top safety barrier and the adjoining structure shall not exceed 75 mm or shall be more than 230 mm.
- d) **WARNING**-Do not use the bunk bed/high bed if any structural part is broken or missing; Replacement parts are between requested from the manufacturer or the store.
- e) it is imperative to always follow the installation instructions and manufacturer's use.
- f) The recommended size of the mattress to be used with the bed is 200*90cm/200*140cm maximum thickness mattress: **13**cm.
- g) It is necessary to ventilate the room in order to maintain a low level moisture and prevent mold growth in the bed and its periphery.
- h) Joining devices should always be tightened properly and regularly verified. Tighten if necessary.

ANLEITUNG

WICHTIG-SORGFÄLTIG DURCHLESEN-FÜR ZUKÜNFTIGE REFERENZ BEWAHREN

- a) **WARNUNG** -Das Oberbett von Etagenbett ist wegen der Verletzungsgefahr durch Stürze nicht für Kinder unter sechs Jahren geeignet.
- b) **WARNUNG** -Etagenbetten und Hochbetten können ein ernstes Verletzungsrisiko darstellen, wenn sie nicht ordnungsgemäß verwendet werden. Befestigen oder hängen Sie niemals etwas an einem Teil des Etagenbettes, das nicht für das Bett bestimmt ist, wie z. B. Seile, Haken, Gurte und Taschen.
- c) **WARNUNG** -Kinder können zwischen Bett und Wand eingeklemmt werden. Um die Gefahr schwerer Verletzungen zu vermeiden, darf der Abstand zwischen der oberen Sicherheitsbarriere und der angrenzenden Konstruktion 75 mm nicht überschreiten oder mehr als 230 mm betragen.
- d) **WARNUNG** -Verwenden Sie das Etagenbett/Hochbett nicht, wenn ein Bauteil beschädigt ist oder fehlt. Ersatzteile werden zwischendurch beim Hersteller oder beim Händler angefordert.
- e) Befolgen Sie unbedingt die Installationsanweisungen und die Gebrauchsanweisung des Herstellers.
- f) Die empfohlene Größe der Matratze für das Bett beträgt 200*90cm/200*140cm maximale Dicke der Matratze: **13** cm.
- g) Es ist notwendig, den Raum zu lüften, um ein niedriges Feuchtigkeitsniveau aufrechtzuerhalten und das Wachstum von Schimmel im Bett und an dessen Peripherie zu verhindern.
- h) Verbindungselemente sollten immer richtig angezogen und regelmäßig überprüft werden. Bei Bedarf festziehen.

Stückliste

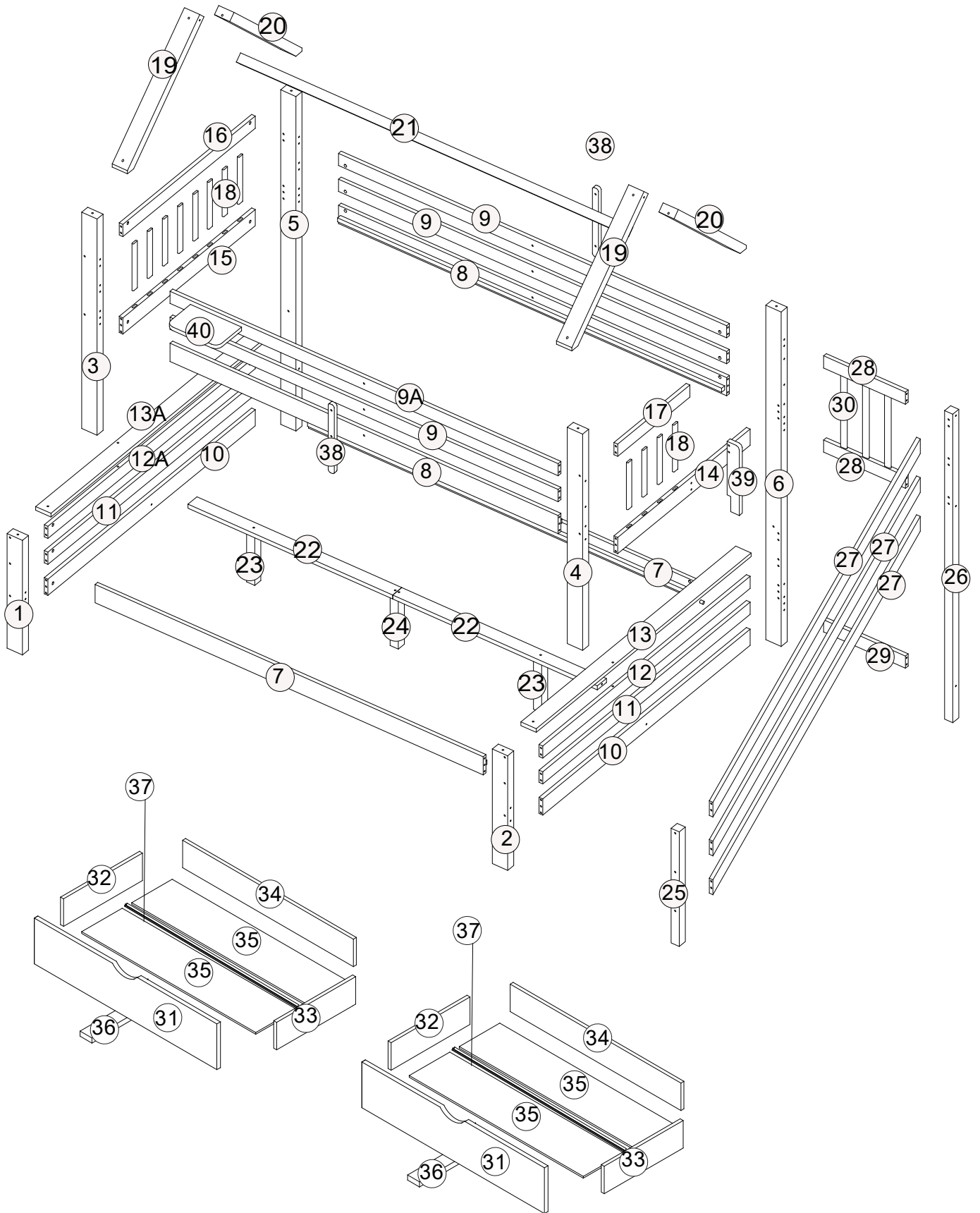

Stückliste

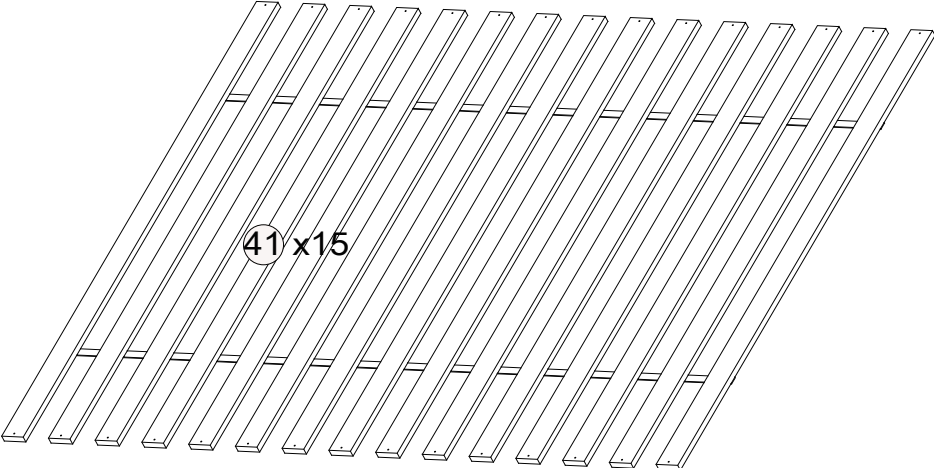
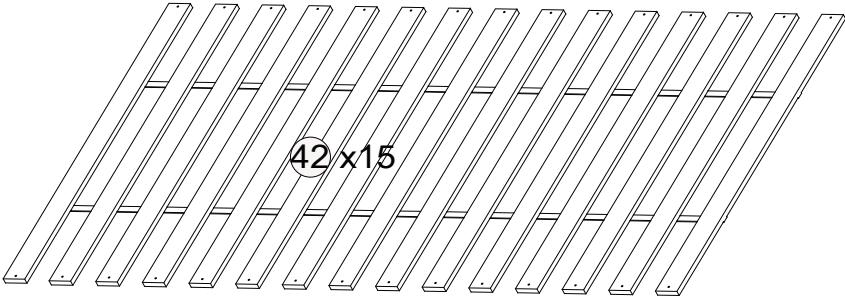
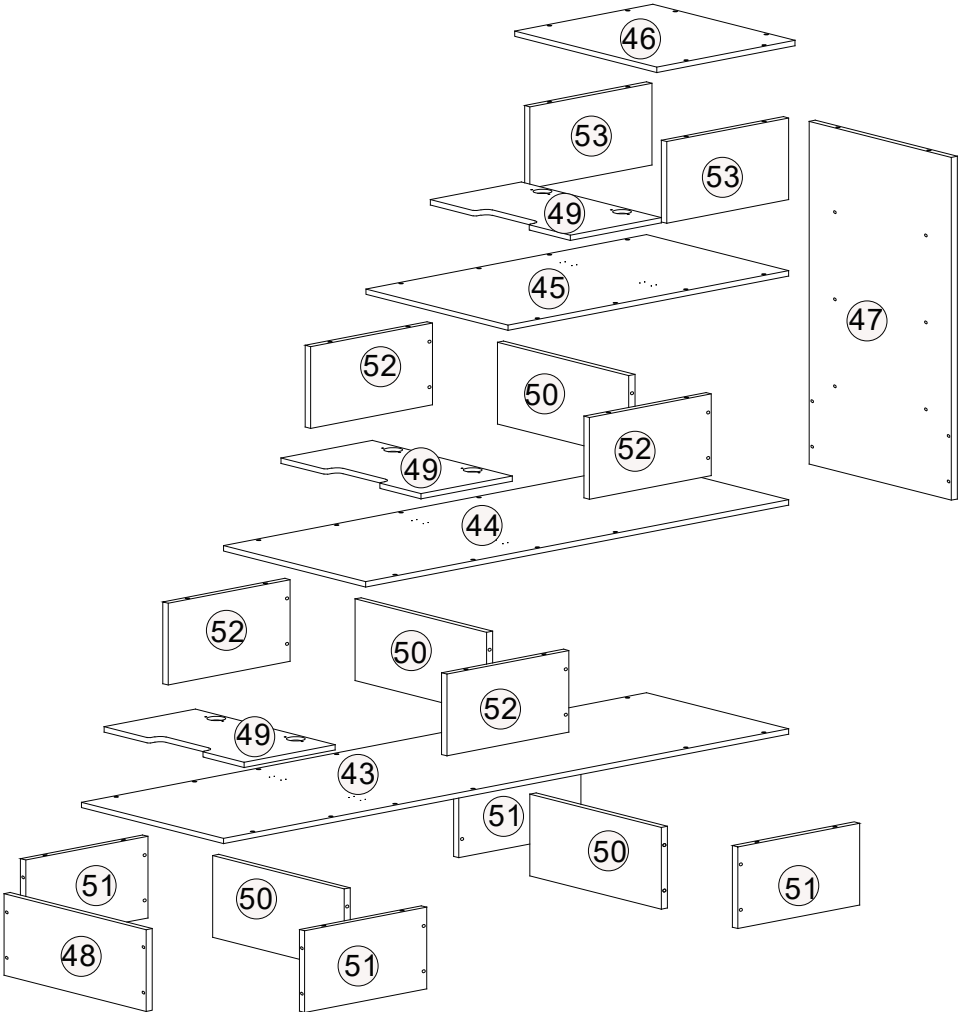

Part List WF319112WAA

⑤ x1 	⑥ x1 	⑦ x2 	⑧ x2 	⑨ x3
⑨A x1 	⑱ x12 	⑳ x1 	㉔ x1 	㉕ x3

Part List WF319113WAA

⑩ x2 	⑪ x2 	⑫ x1 	⑫A x1 	⑬ x1
⑬A x1 	⑲ x2 	⑳ x2 	㉒ x2 	㉘ x2
㉙ x1 	㉛ x1 	㉝ x15 	㉞ x4 	











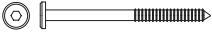
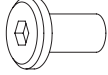
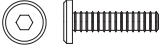
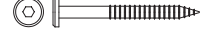
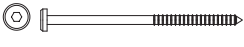
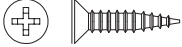

Part List WF319114WAA

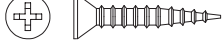
① x1 	② x1 	③ x1 	④ x1 	⑭ x1
⑮ x1 	⑯ x1 	⑰ x1 	㉓ x2 	㉔ x1
㉕ x1 	⑳ x3 	㉑ x2 	㉒ x2 	㉓ x2
㉔ x2 	㉕ x4 	㉖ x2 	㉗ x2 	㉘ x2
㉙ x15 				

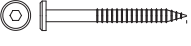
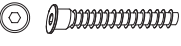
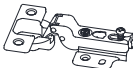
Part List WF319115WAA

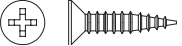
④① x1 	④③ x1 	④④ x1 	④⑤ x1 	④⑥ x1
④⑦ x1 	④⑧ x1 	④⑨ x3 	⑤① x4 	⑤② x4
⑤③ x2 				

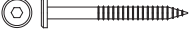
Hardware List WF319114WAA

<p>A x64</p>  <p>Φ8x30</p>	<p>B x22</p>  <p>M6x90</p>	<p>C x50</p> 	<p>D x1</p>  <p>M6x60</p>	<p>E x8</p> 
<p>F x6</p>  <p>M6x30</p>	<p>G x23</p>  <p>Φ6x70</p>	<p>H x27</p>  <p>M6x120</p>	<p>I x16</p>  <p>Φ3.5x16</p>	<p>J x60</p>  <p>Φ4x30</p>
<p>K x2</p>  <p>M6x50</p>	<p>L x8</p>  <p>Φ4x50</p>	<p>M x12</p> 	<p>N x12</p> 	<p>O x2</p>  <p>Φ6x110</p>
<p>P x66</p>  <p>Φ7x60</p>	<p>Q x6</p> 	<p>R x8</p> 	<p>S x36</p>  <p>Φ4x12</p>	<p>T x1</p> 
<p>U x2</p>  <p>Φ6x90</p>	<p>V x2</p>  <p>Φ15</p>			



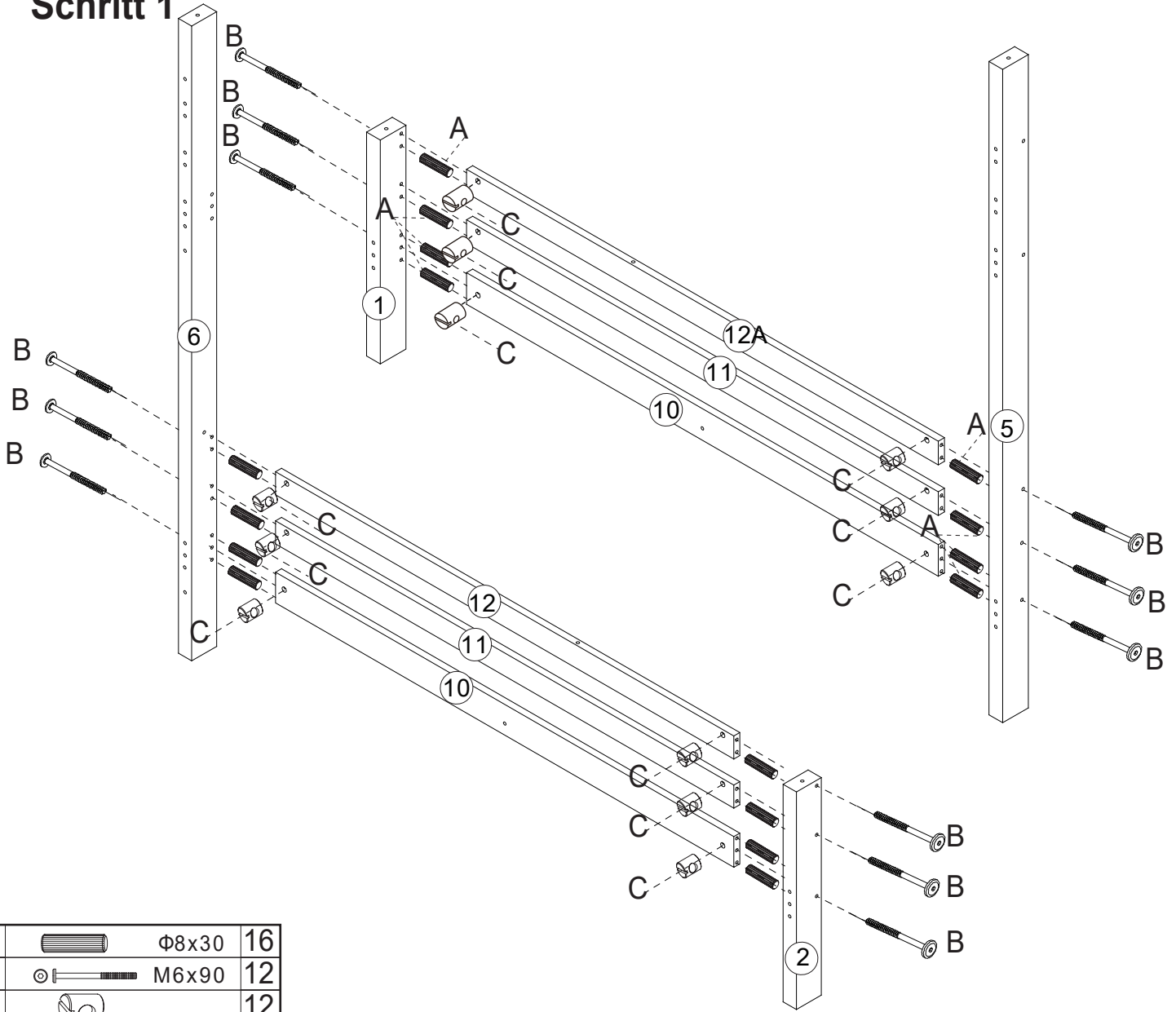

Schritt 1

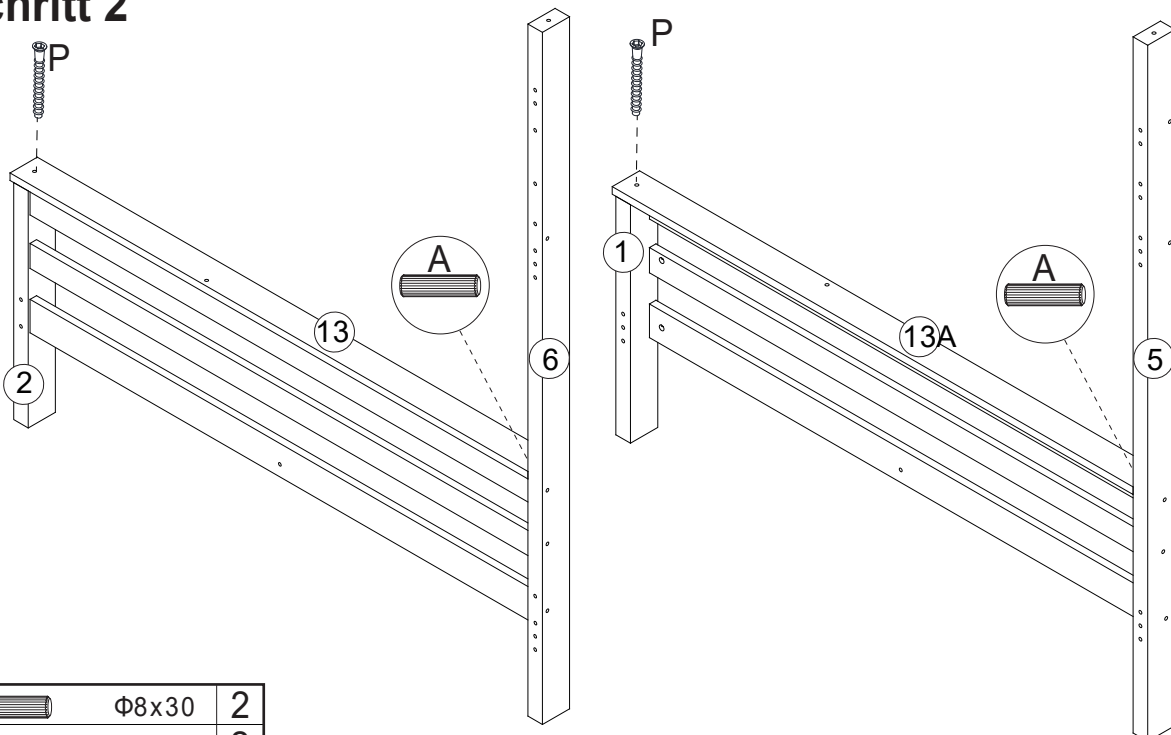

Schritt 2



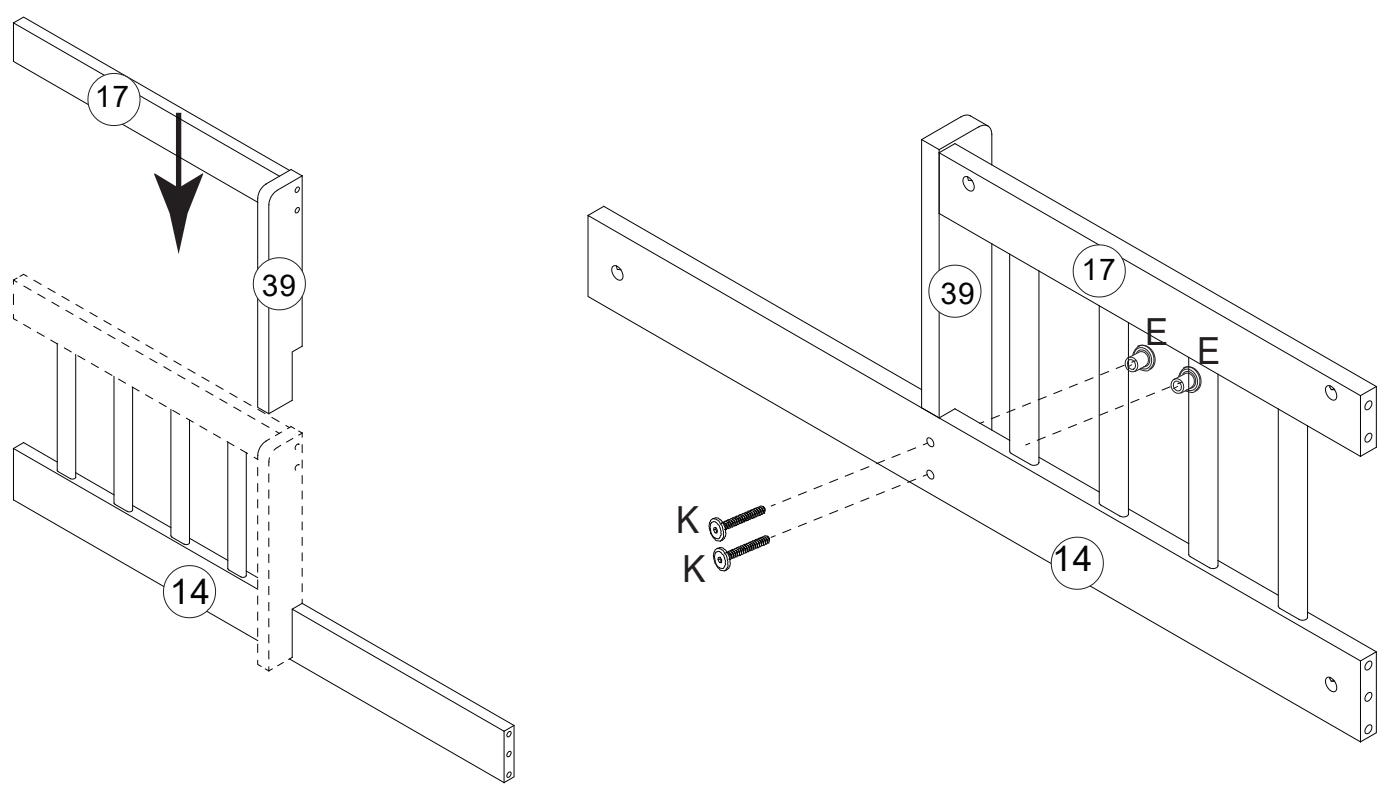
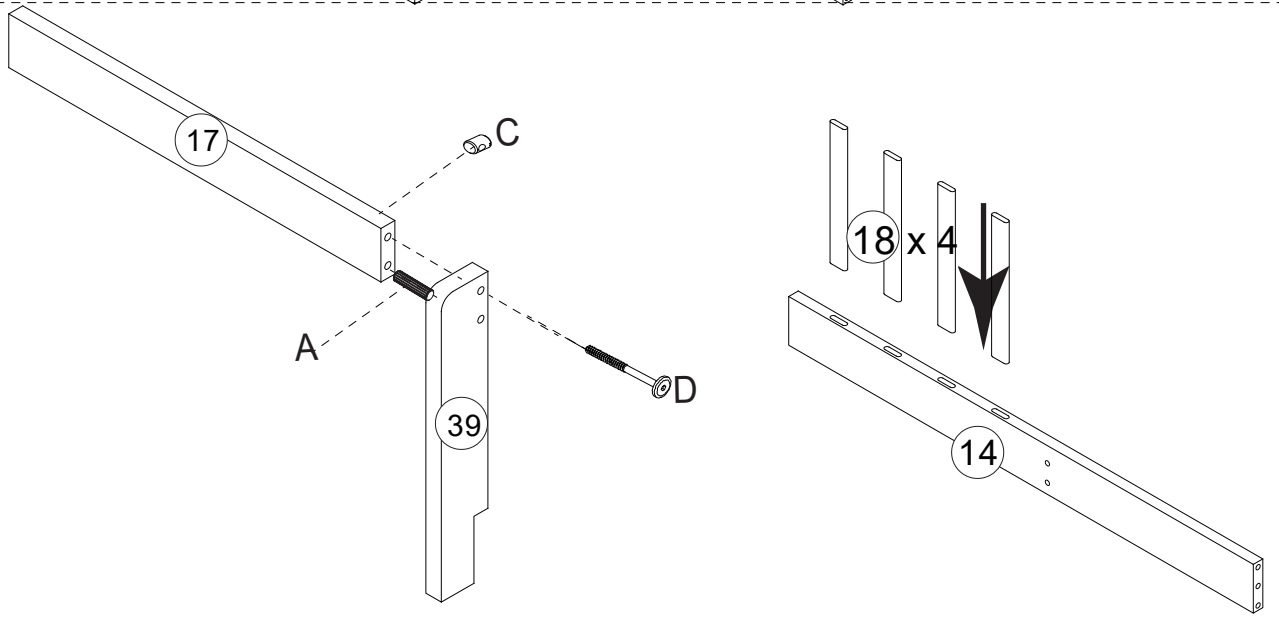
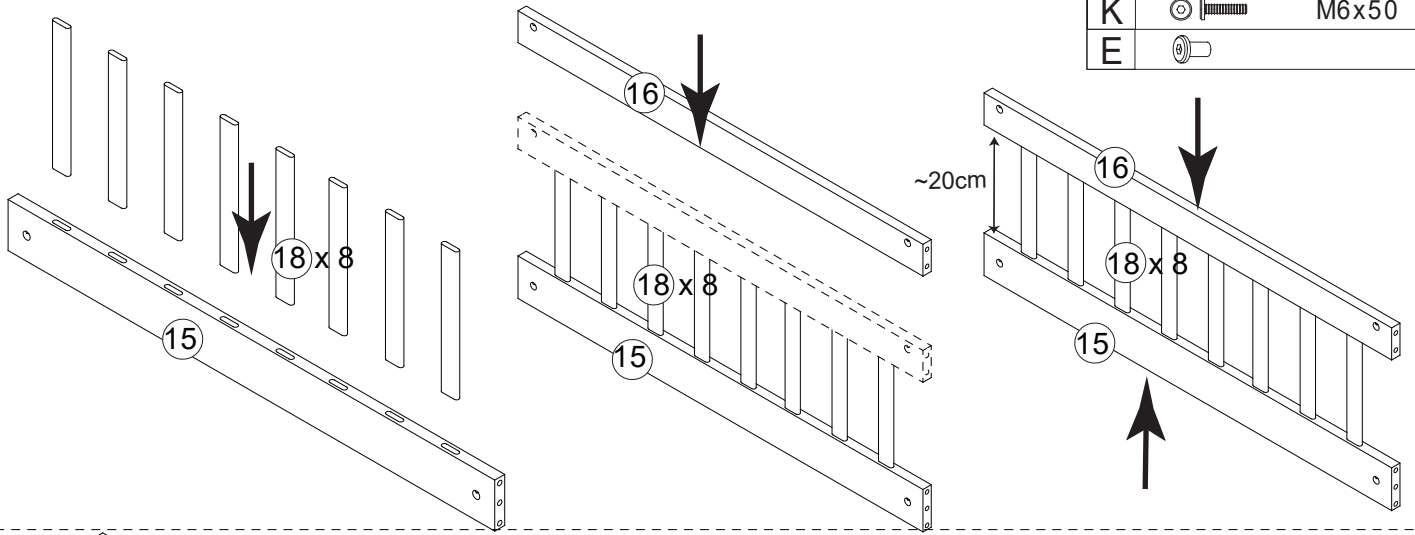

Schritt 3

A		Φ8x30	1
D		M6x60	1
C			1
K		M6x50	2
E			2





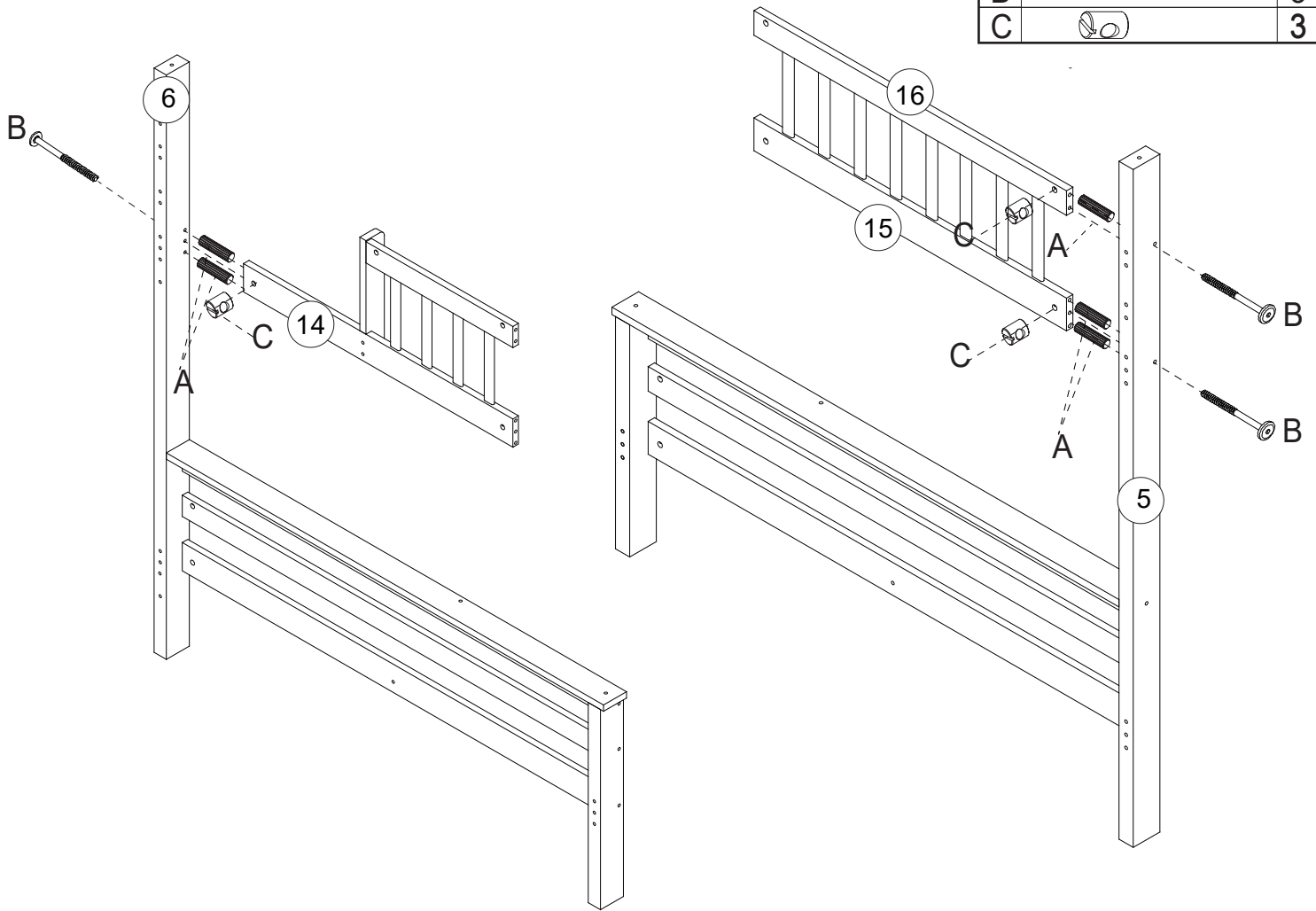

Schritt 4

A		Φ8x30	5
B		M6x90	3
C			3



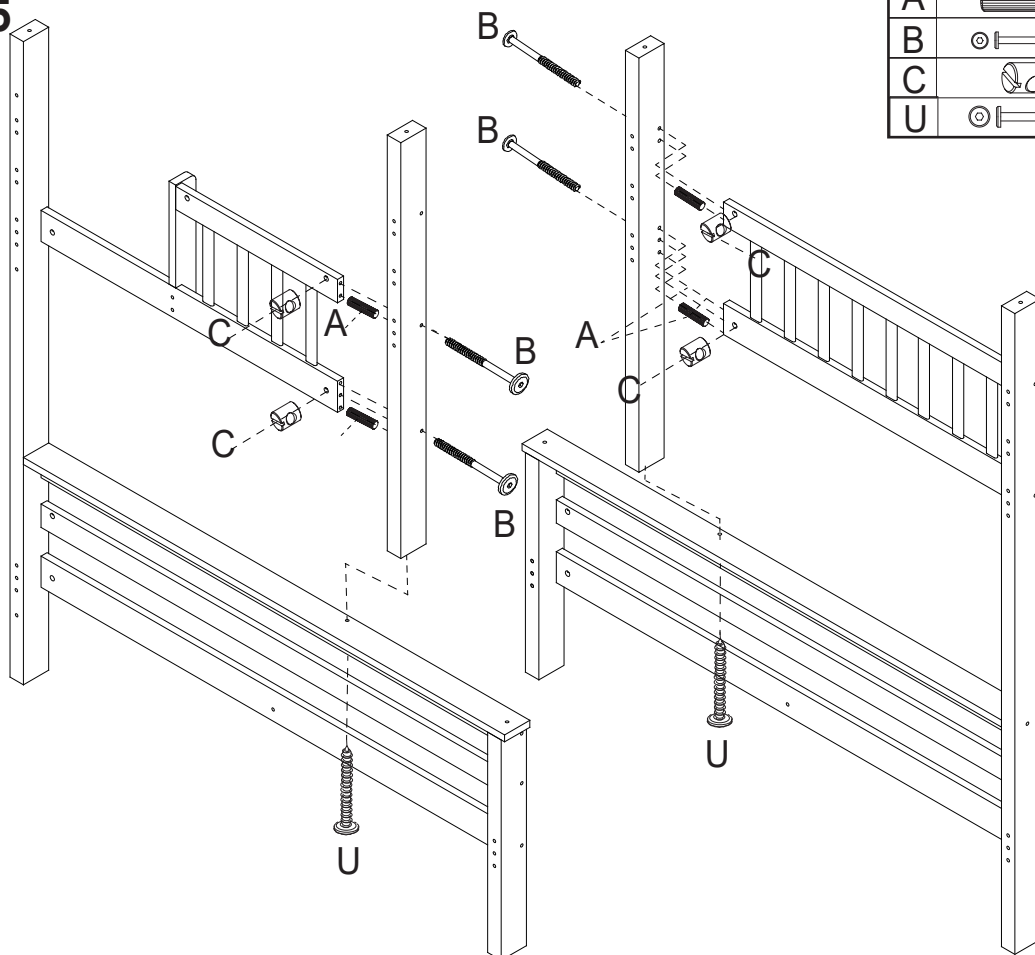

Schritt 5

A		Φ8x30	4
B		M6x90	4
C			4
U		Φ6x90	2

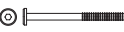

Schritt 6

A		Φ8x30	16
H		M6x120	24
C			24

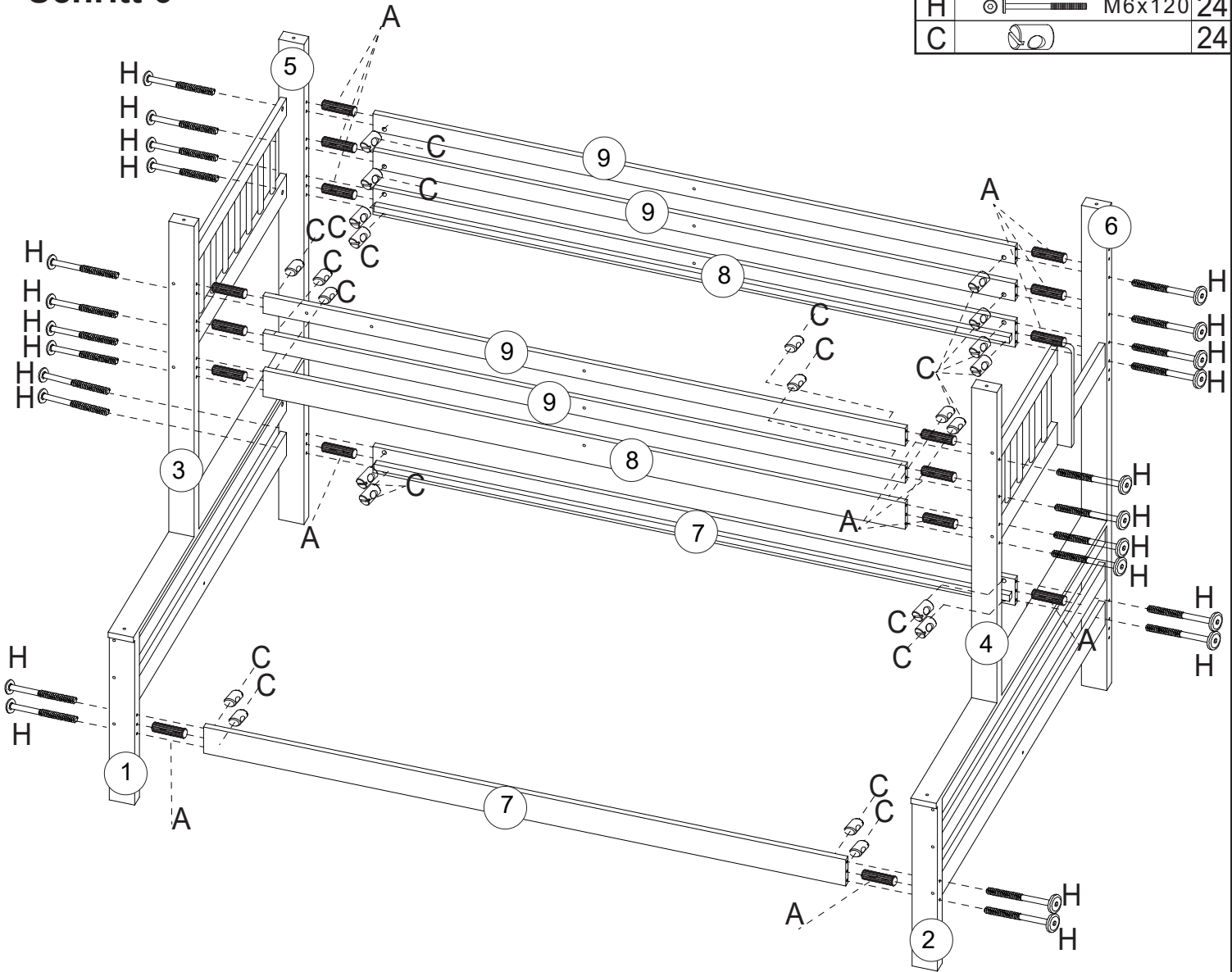

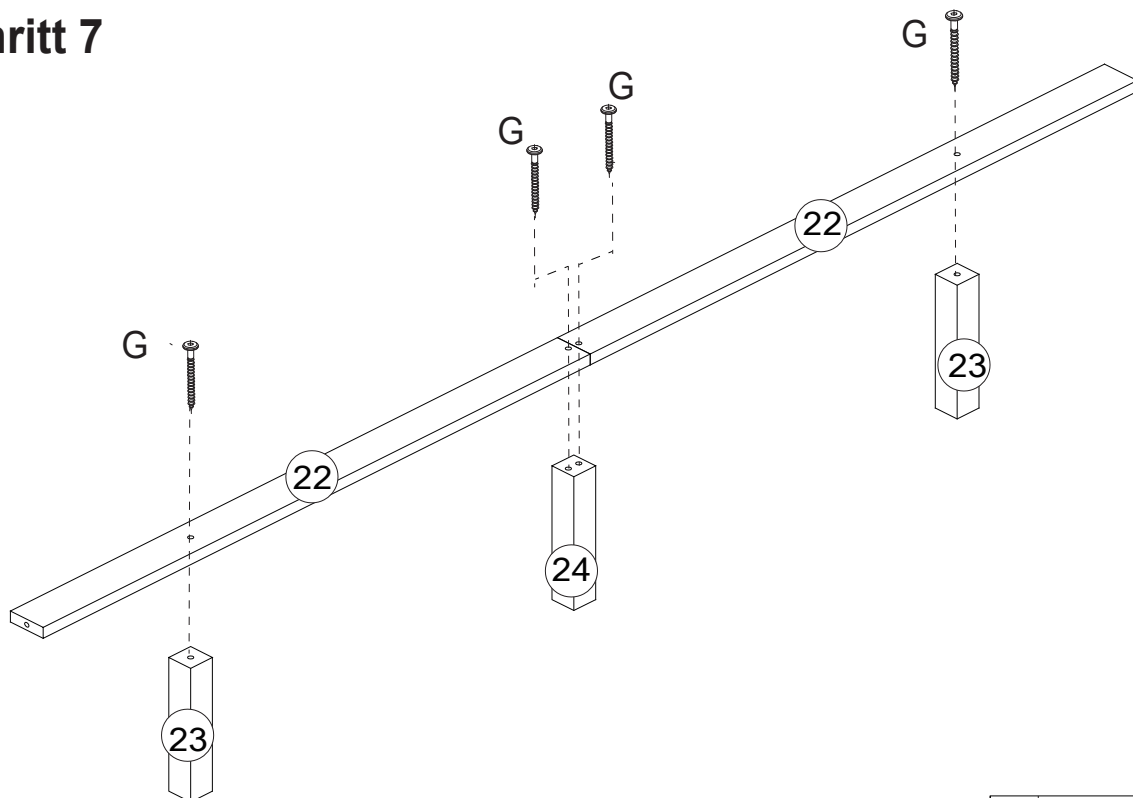

Schritt 7



G		Φ6x70	4
---	---	-------	---

Schritt 8

E			6
F		M6x30	6
G		Φ6x70	4

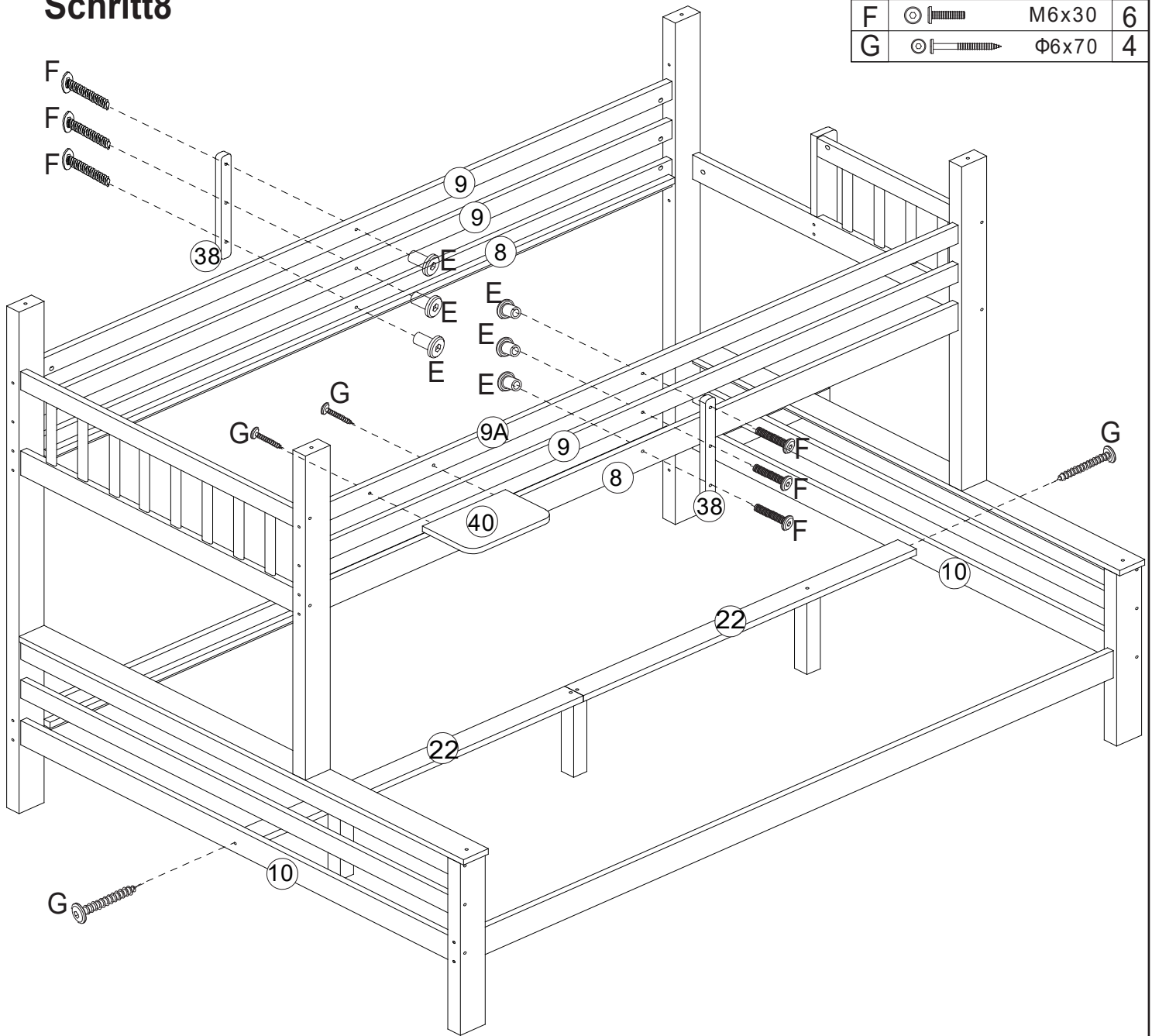

Schritt 9

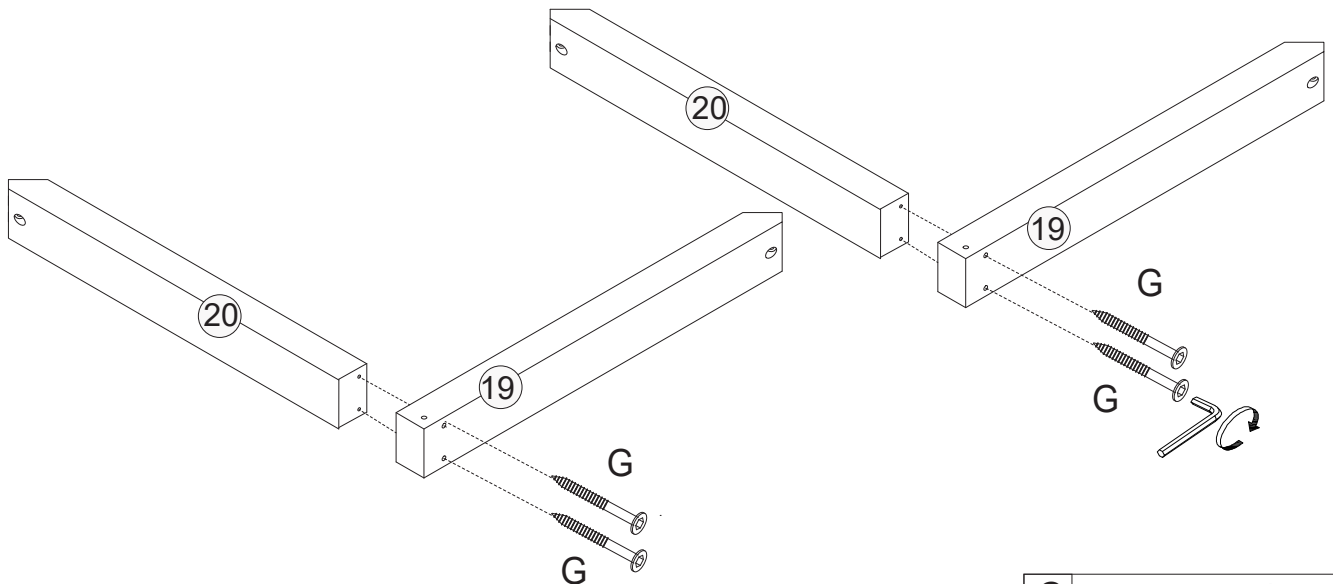

G		Φ6x70	4
---	---	-------	---

Schritt 10

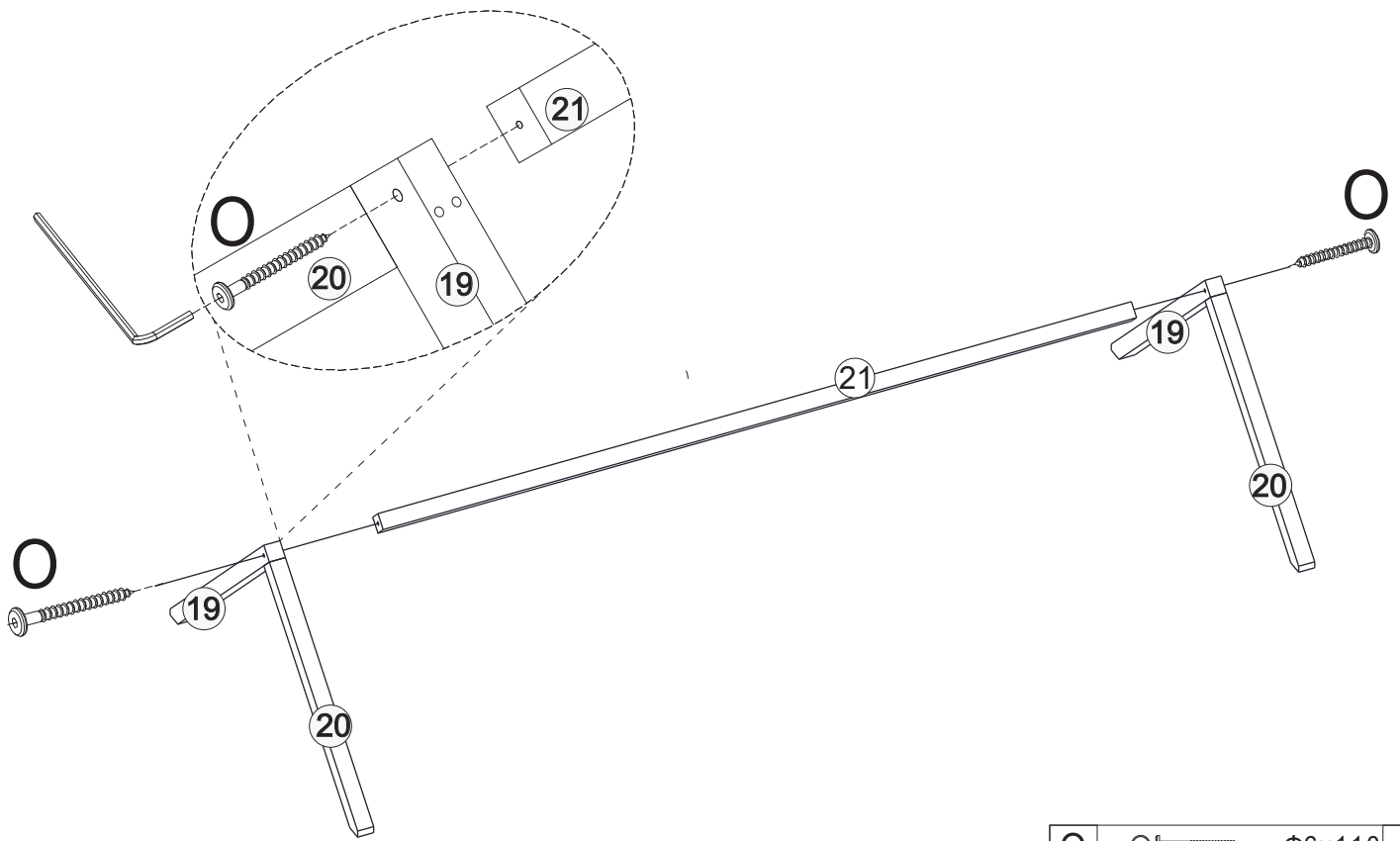

O  $\Phi 6 \times 110$ 2

Schritt 11

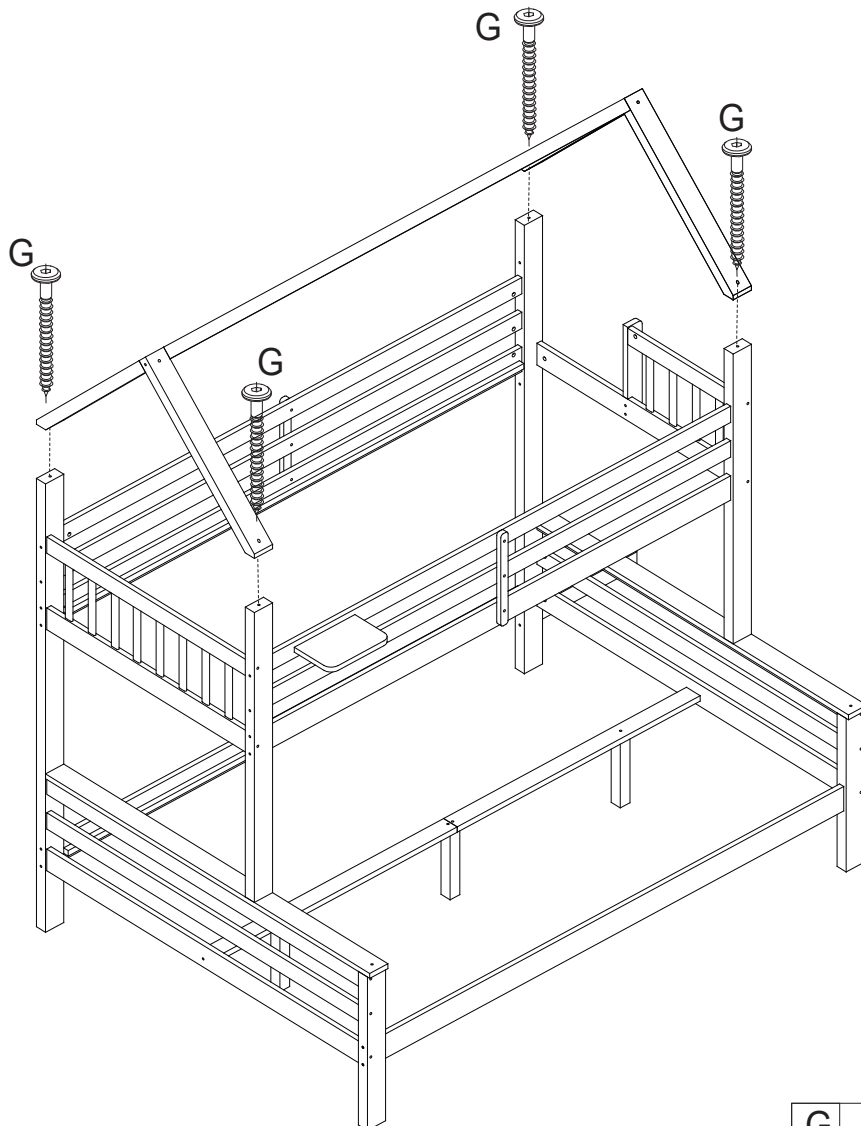



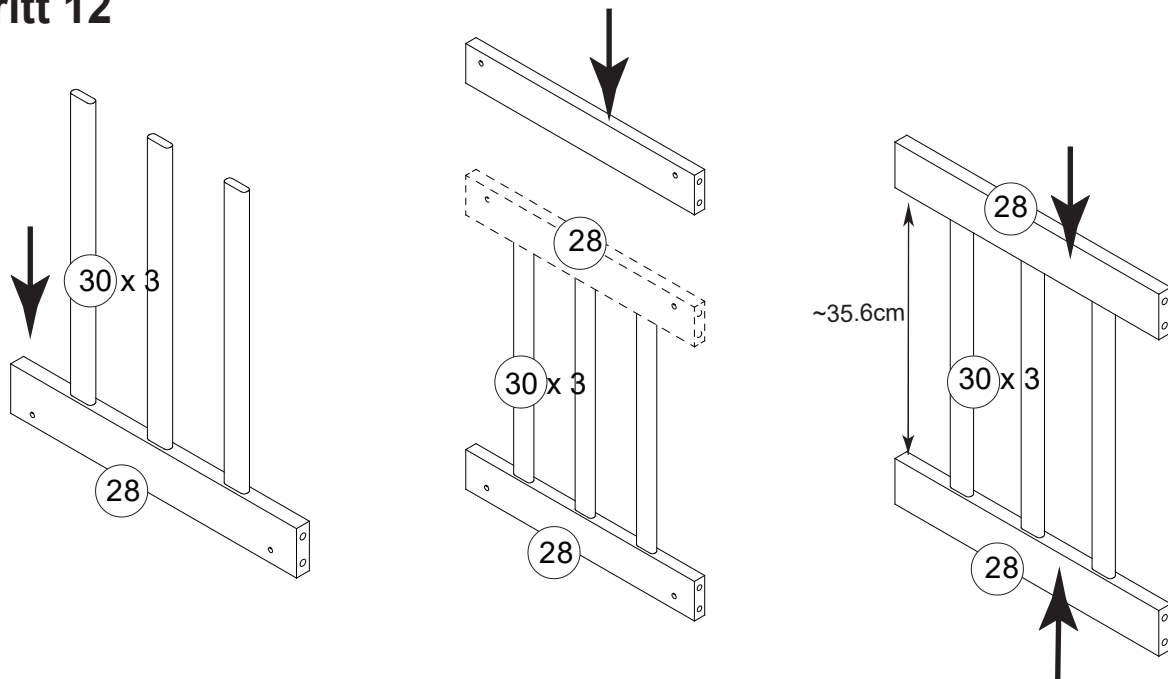

G  $\Phi 6 \times 70$ 4

Schritt 12



Schritt 13

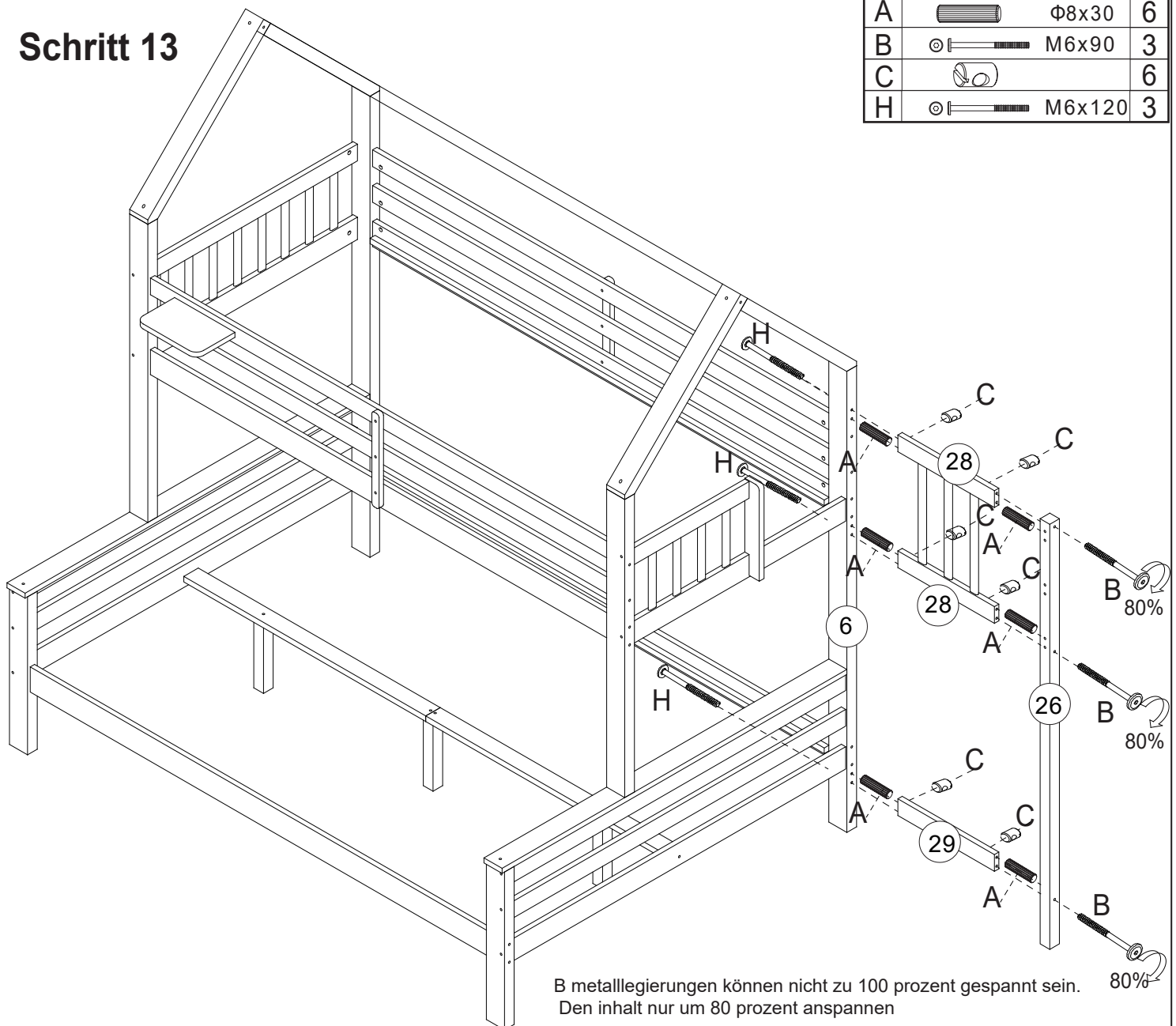

A		Φ8x30	6
B		M6x90	3
C			6
H		M6x120	3



B Metalllegierungen können nicht zu 100 Prozent gespannt sein.
Den Inhalt nur um 80 Prozent anspannen

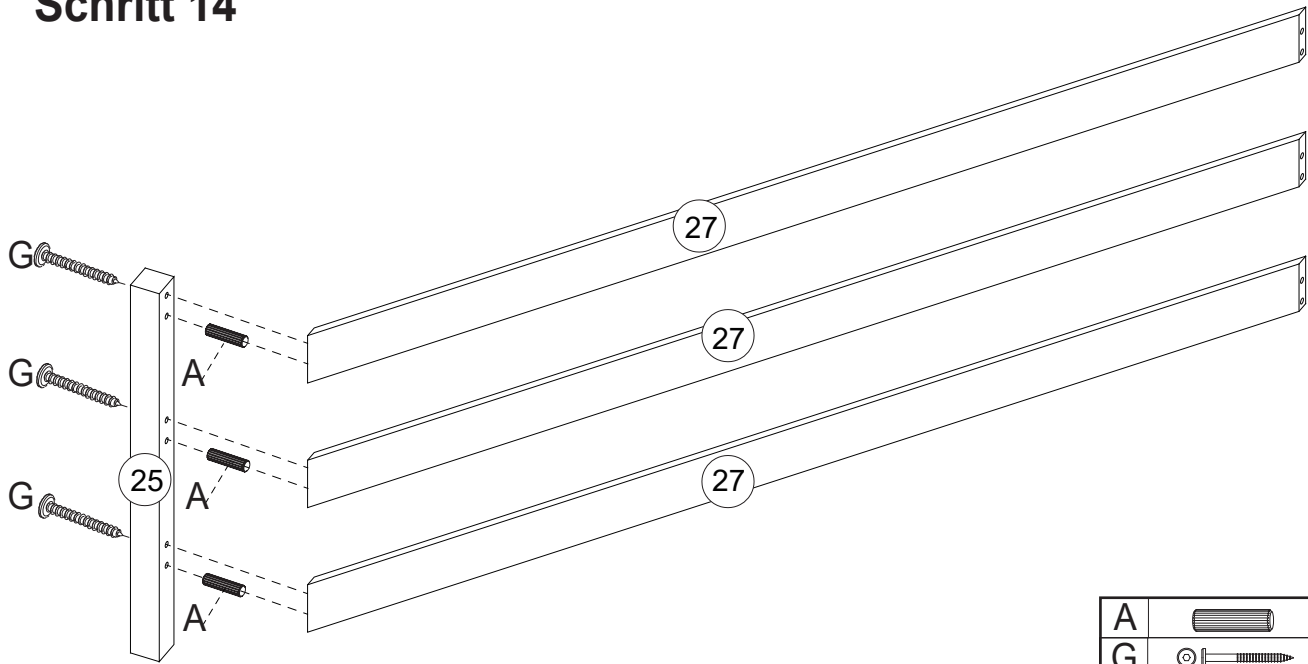

Schritt 14

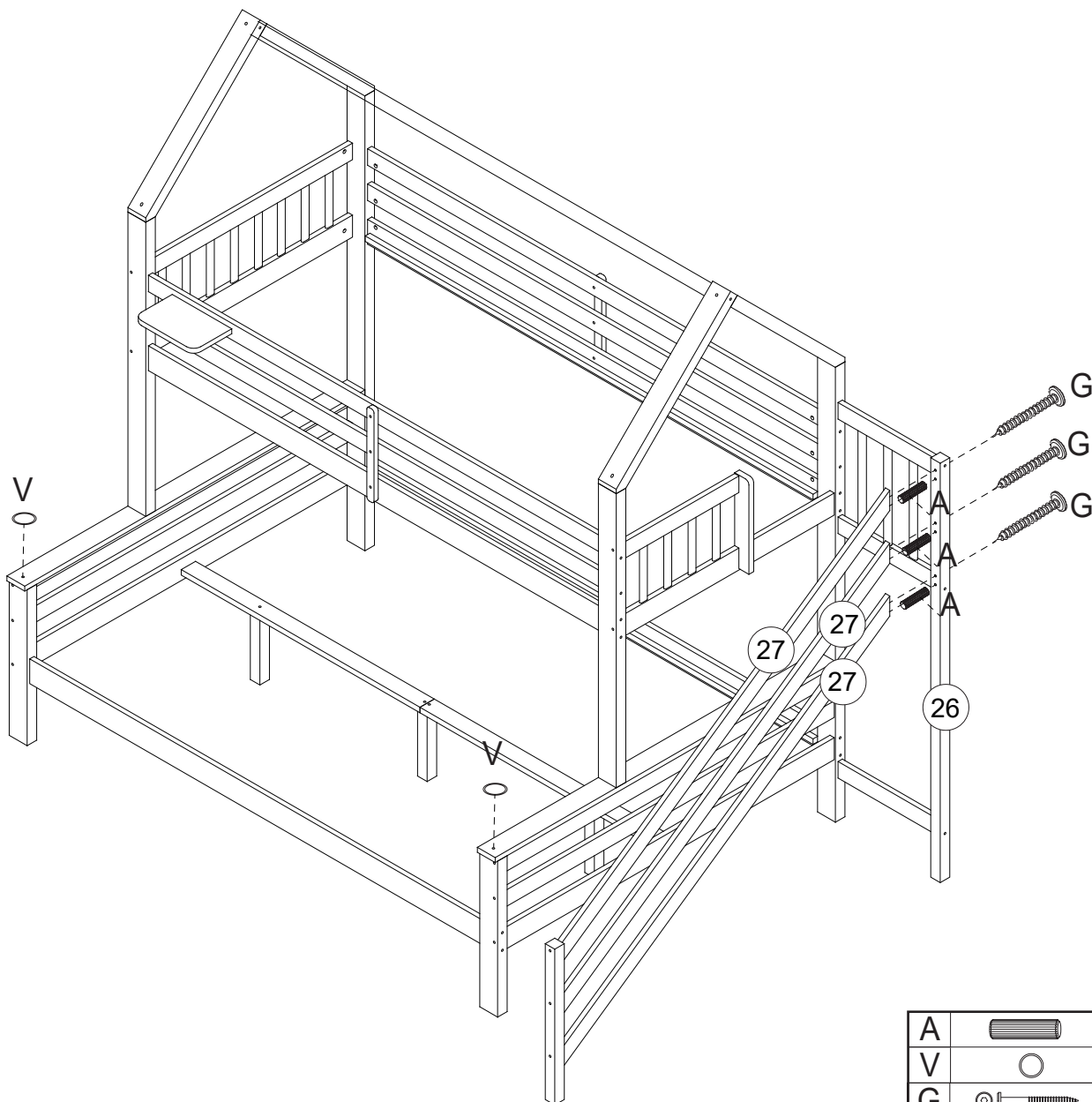

A		Φ8x30	3
G		Φ6x70	3

Schritt 15

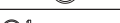

A		Φ8x30	3
V		Φ15	2
G		Φ6x70	3

Schritt 17

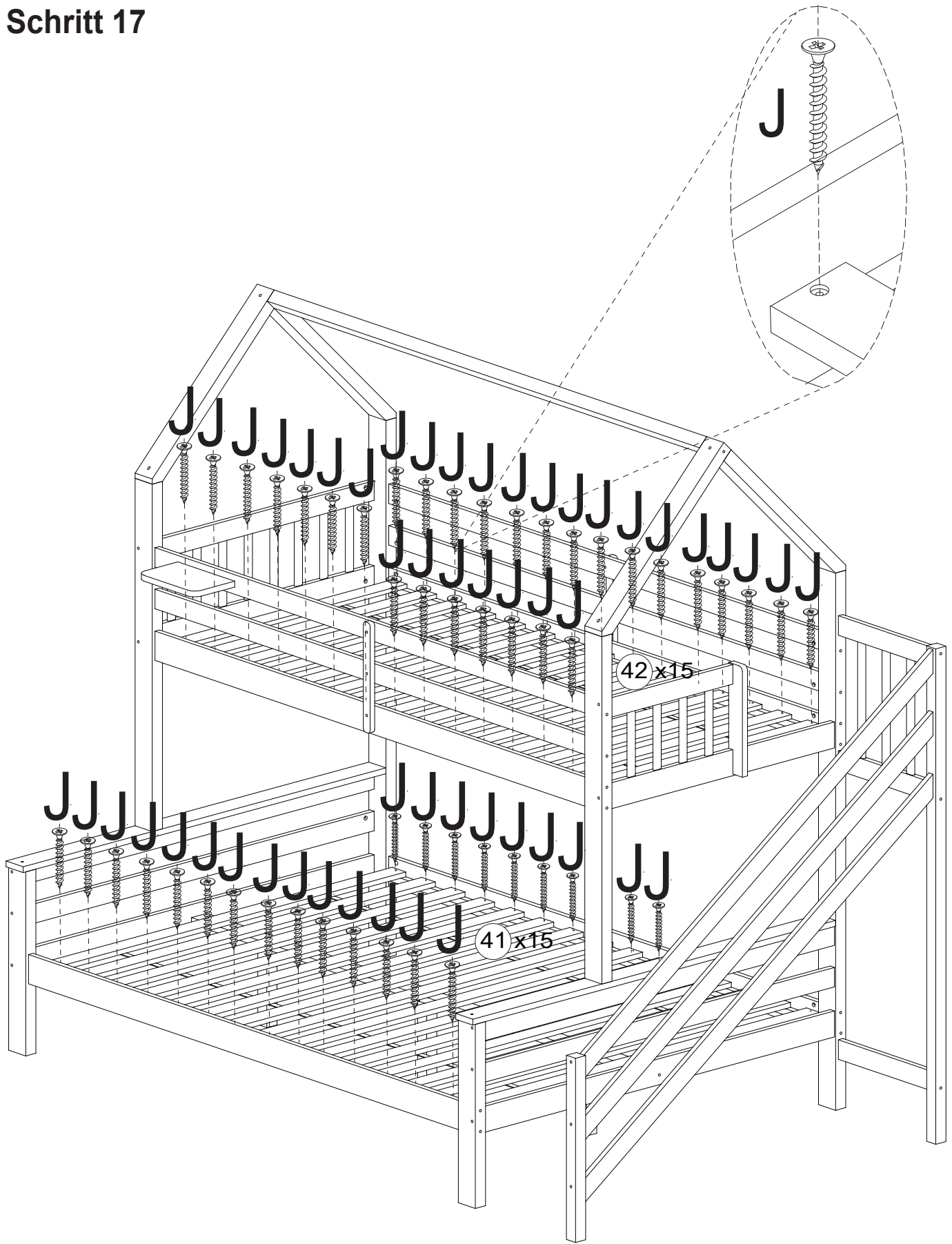

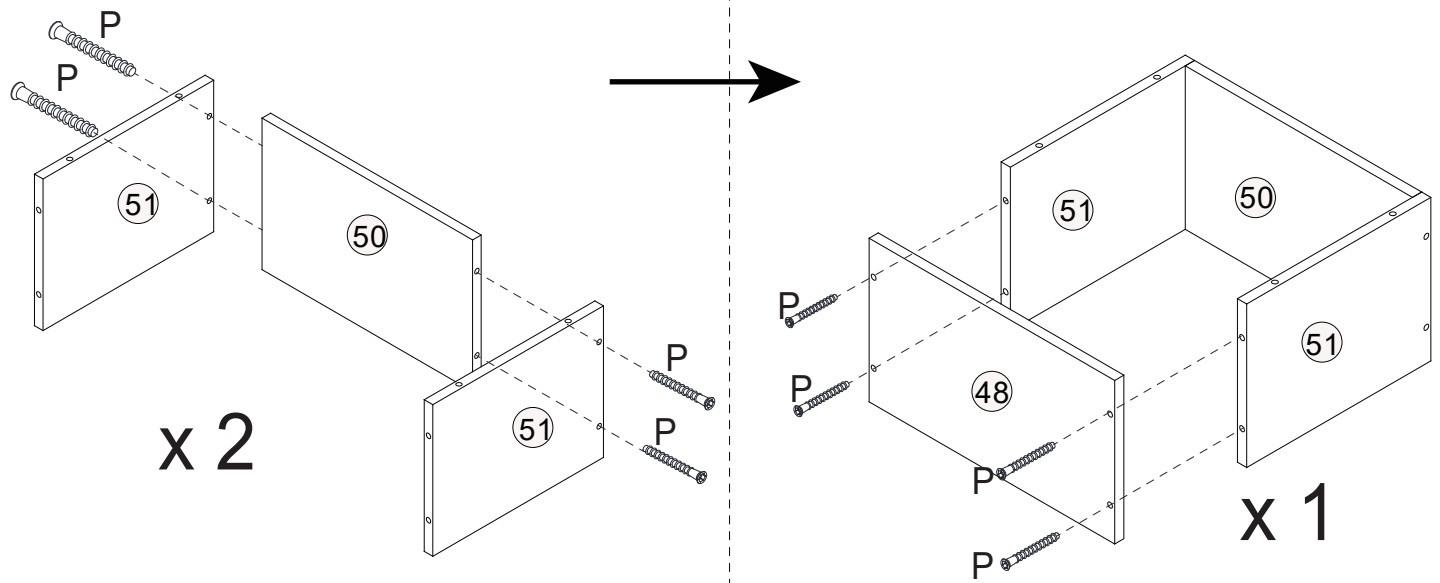

Schritt 18

P		$\Phi 7 \times 60$	12
---	---	--------------------	----

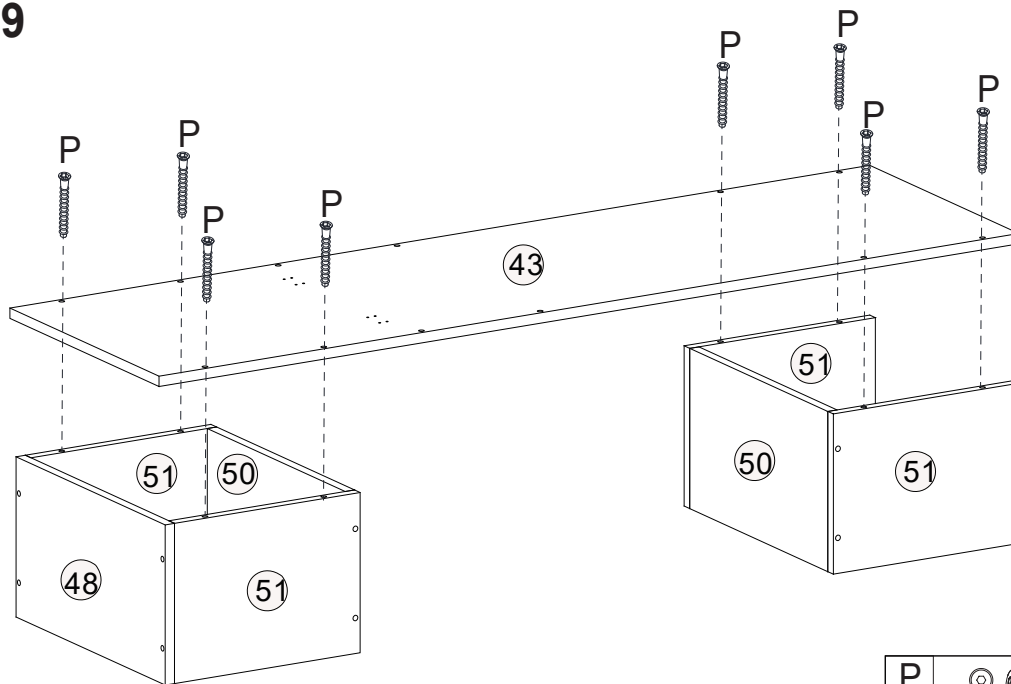

Schritt 19



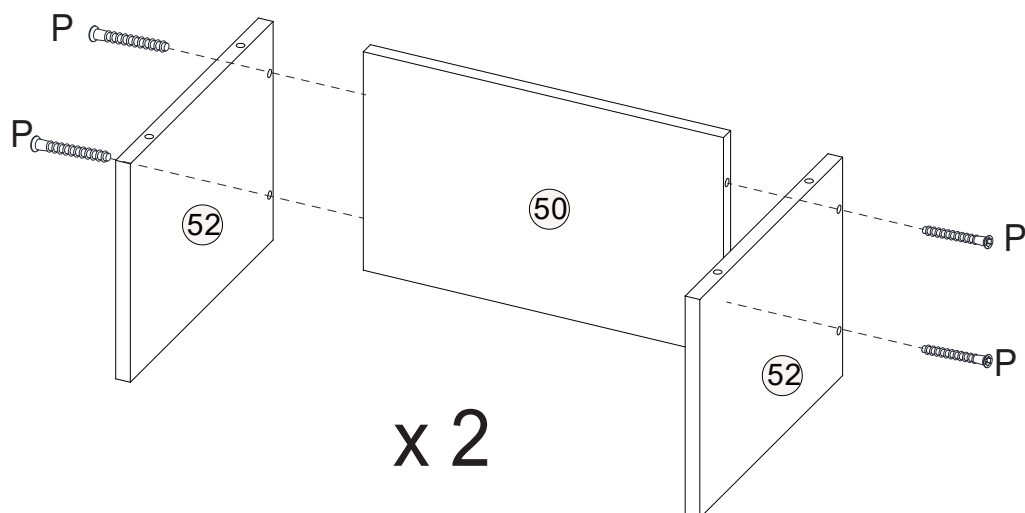

P		$\Phi 7 \times 60$	8
P		$\Phi 7 \times 60$	8

Schritt 20

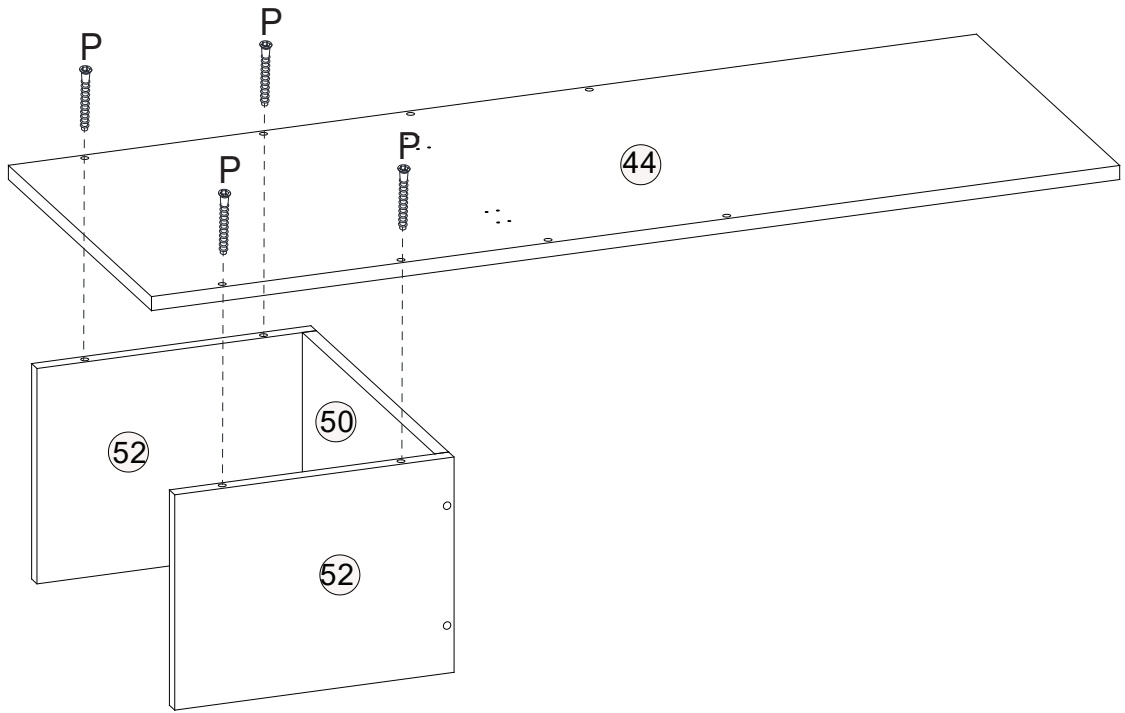

Schritt 21



P		$\Phi 7 \times 60$	4
P		$\Phi 7 \times 60$	8

Schritt 22

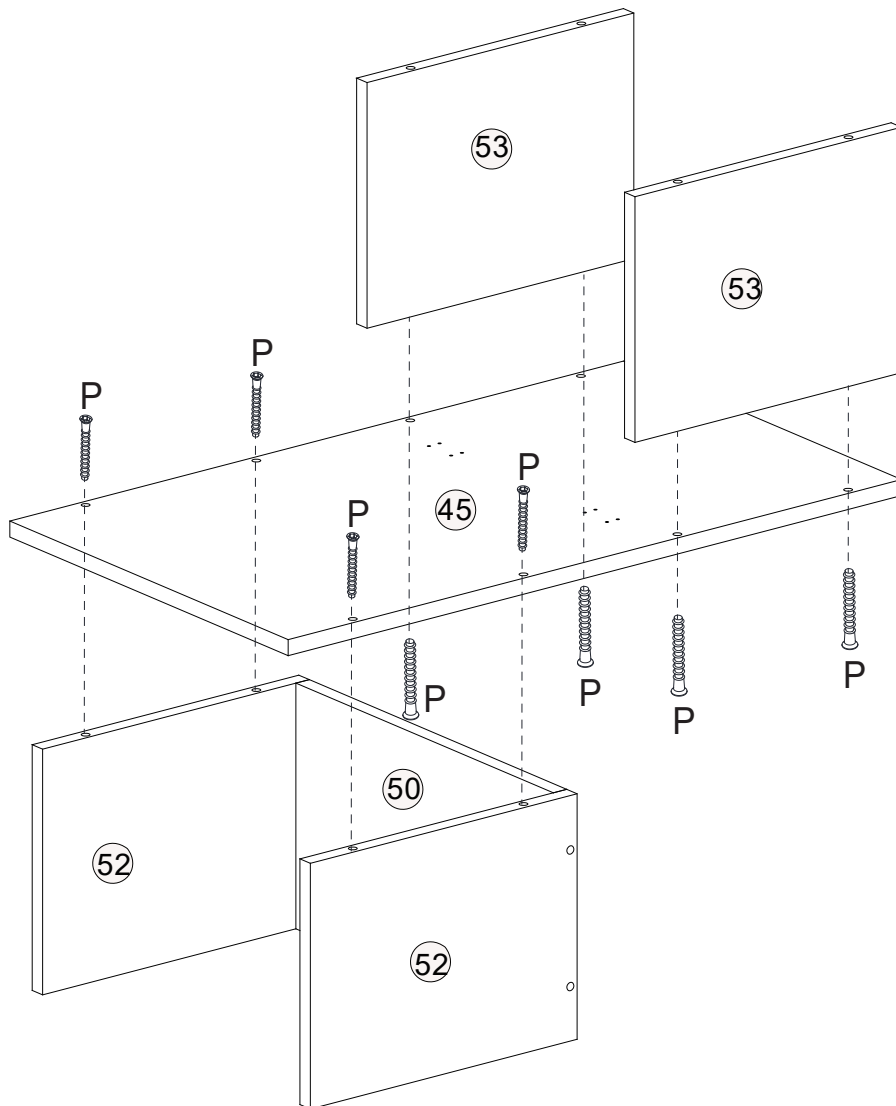

Schritt 23

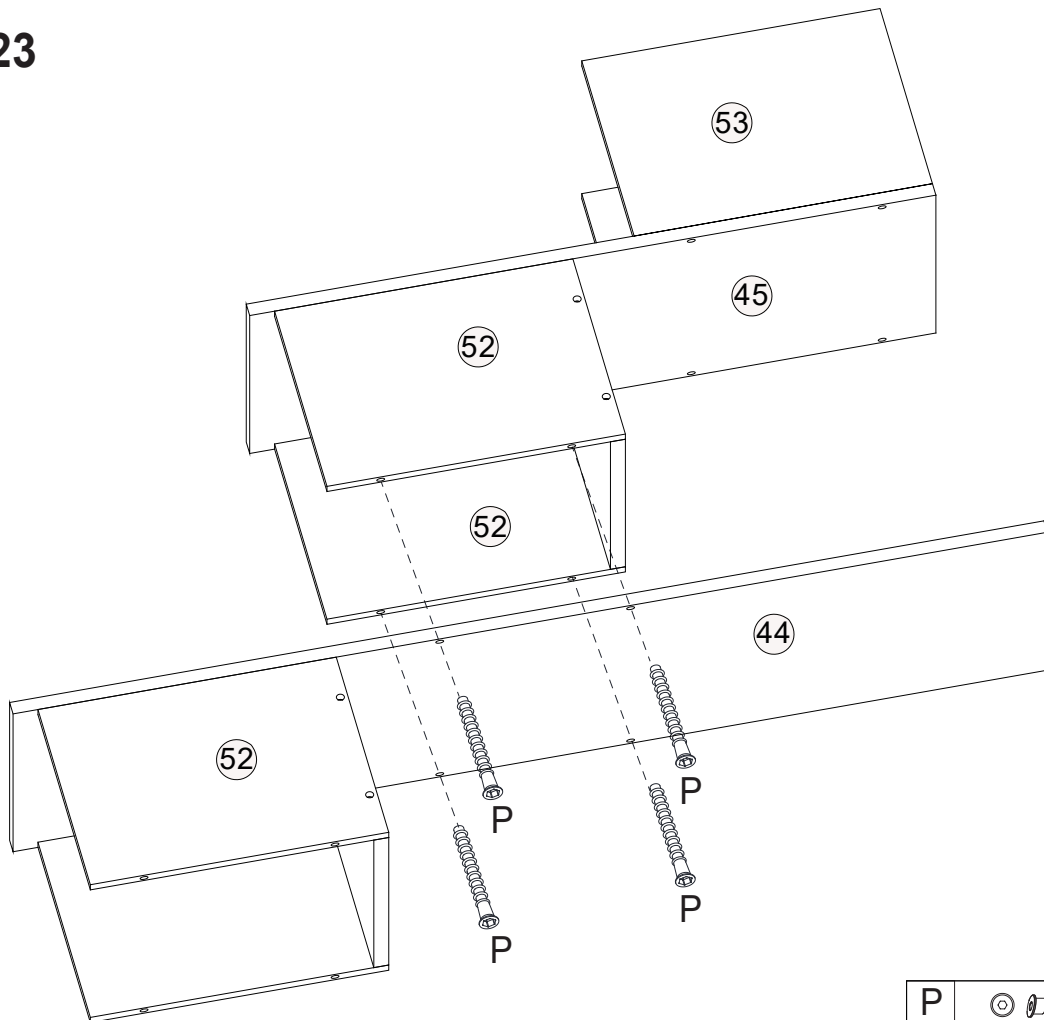

P	⊙  $\Phi 7 \times 60$	4
P	⊙  $\Phi 7 \times 60$	4

Schritt 24

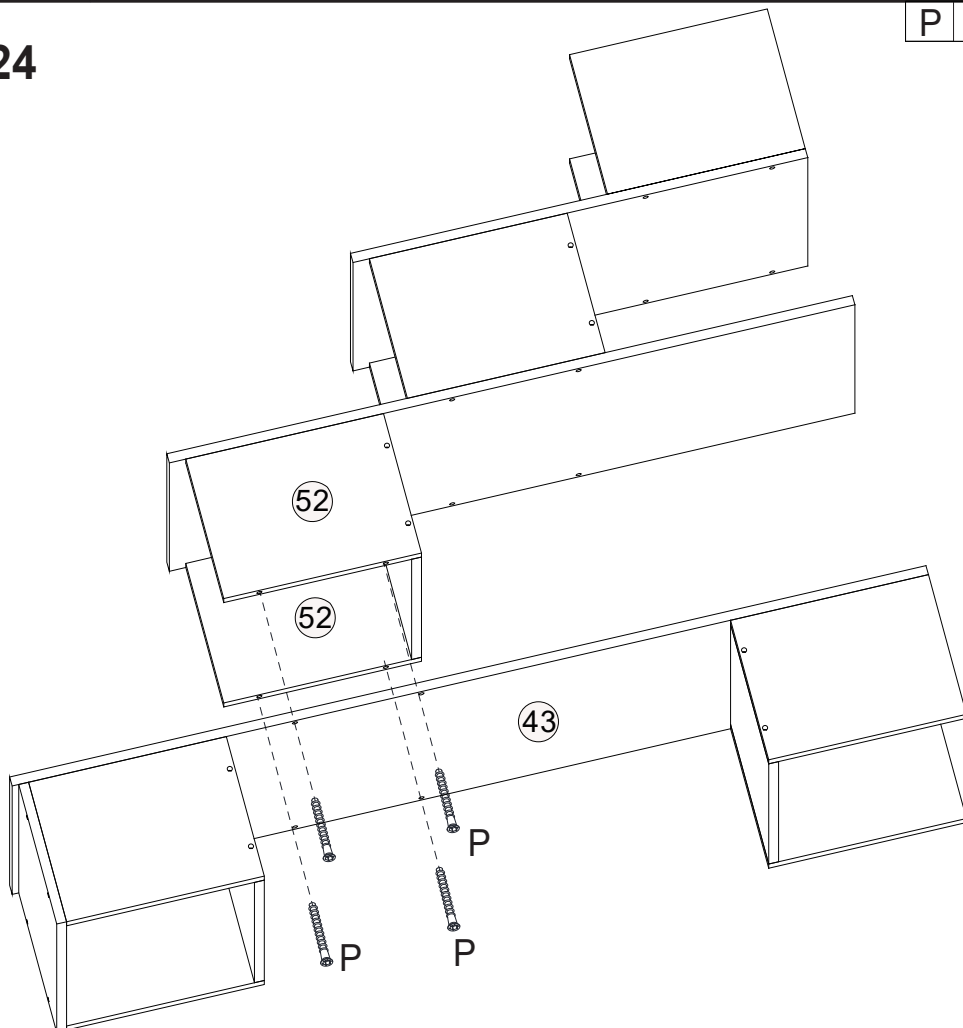

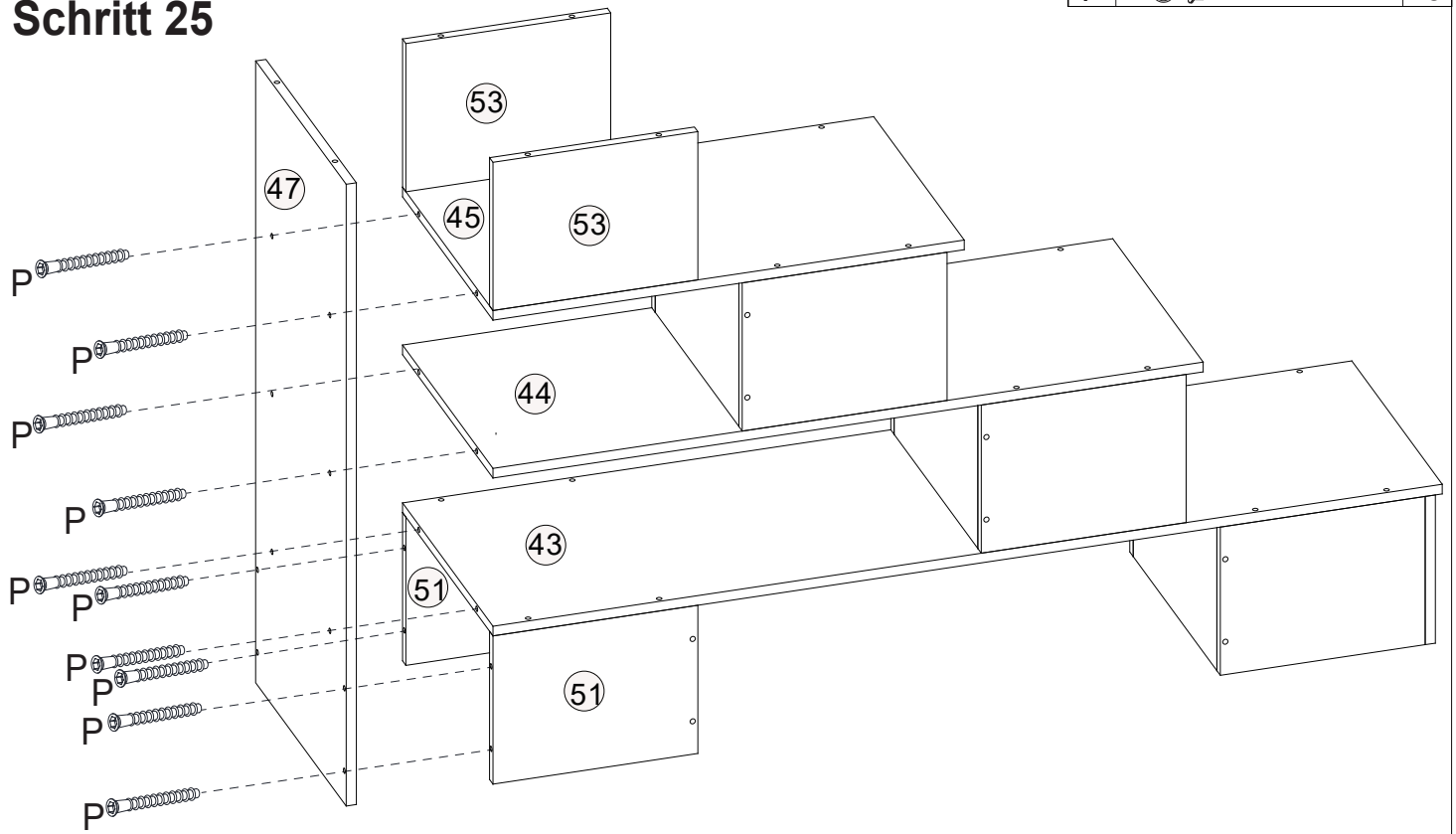

Schritt 25

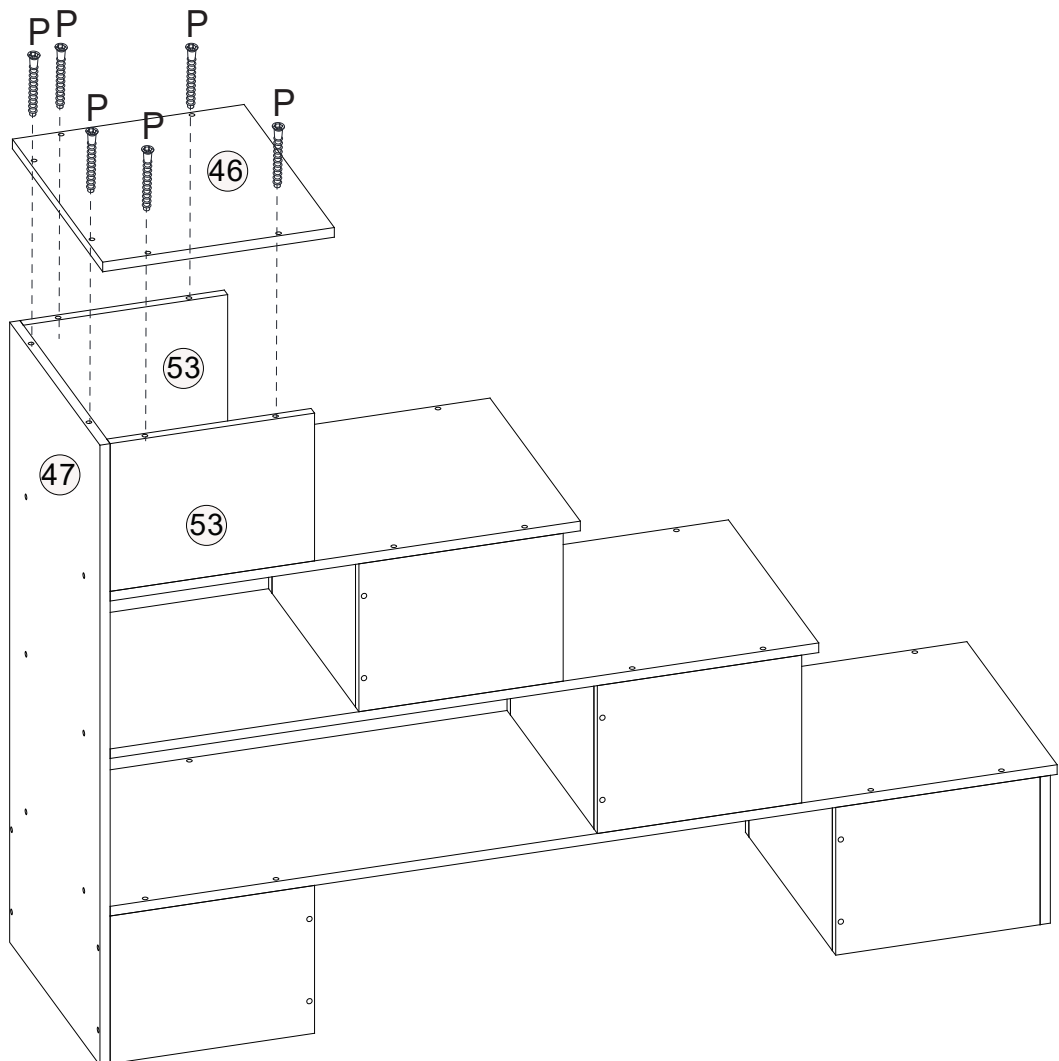

Schritt 26



Schritt 27

S	 $\Phi 4 \times 12$	12
Q		6

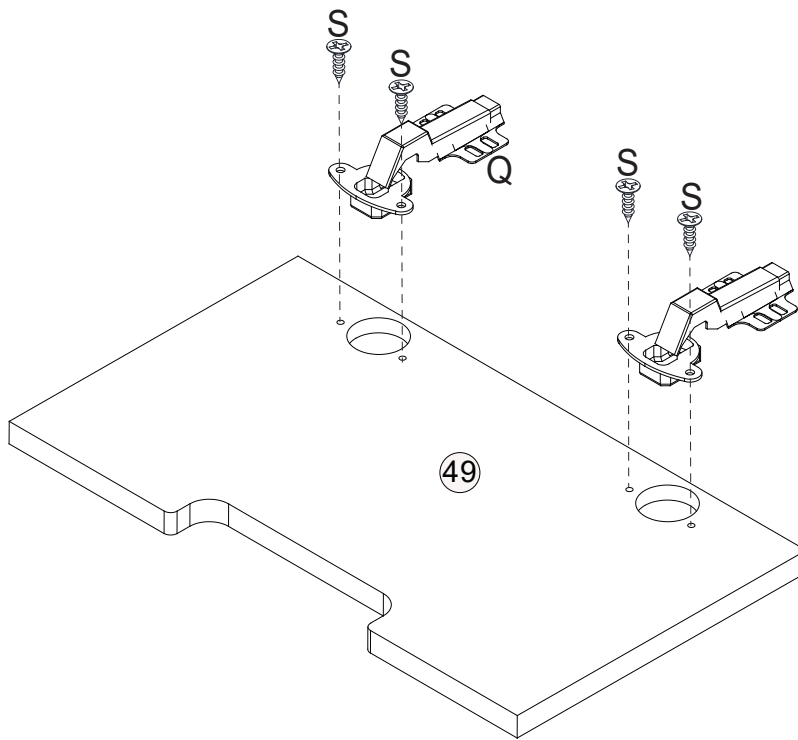

x 3

Schritt 28



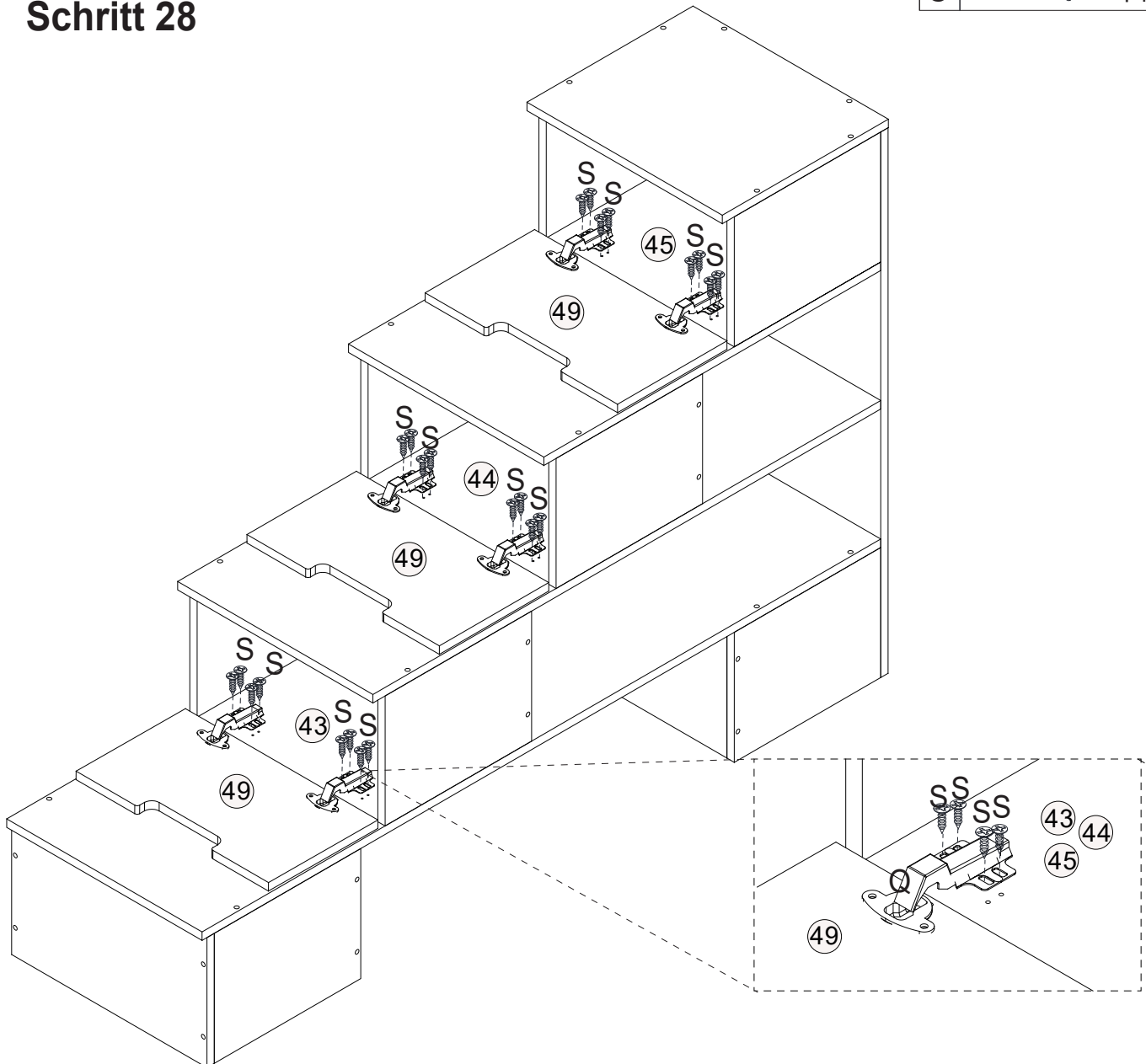

S	 $\Phi 4 \times 12$	24
---	--	----

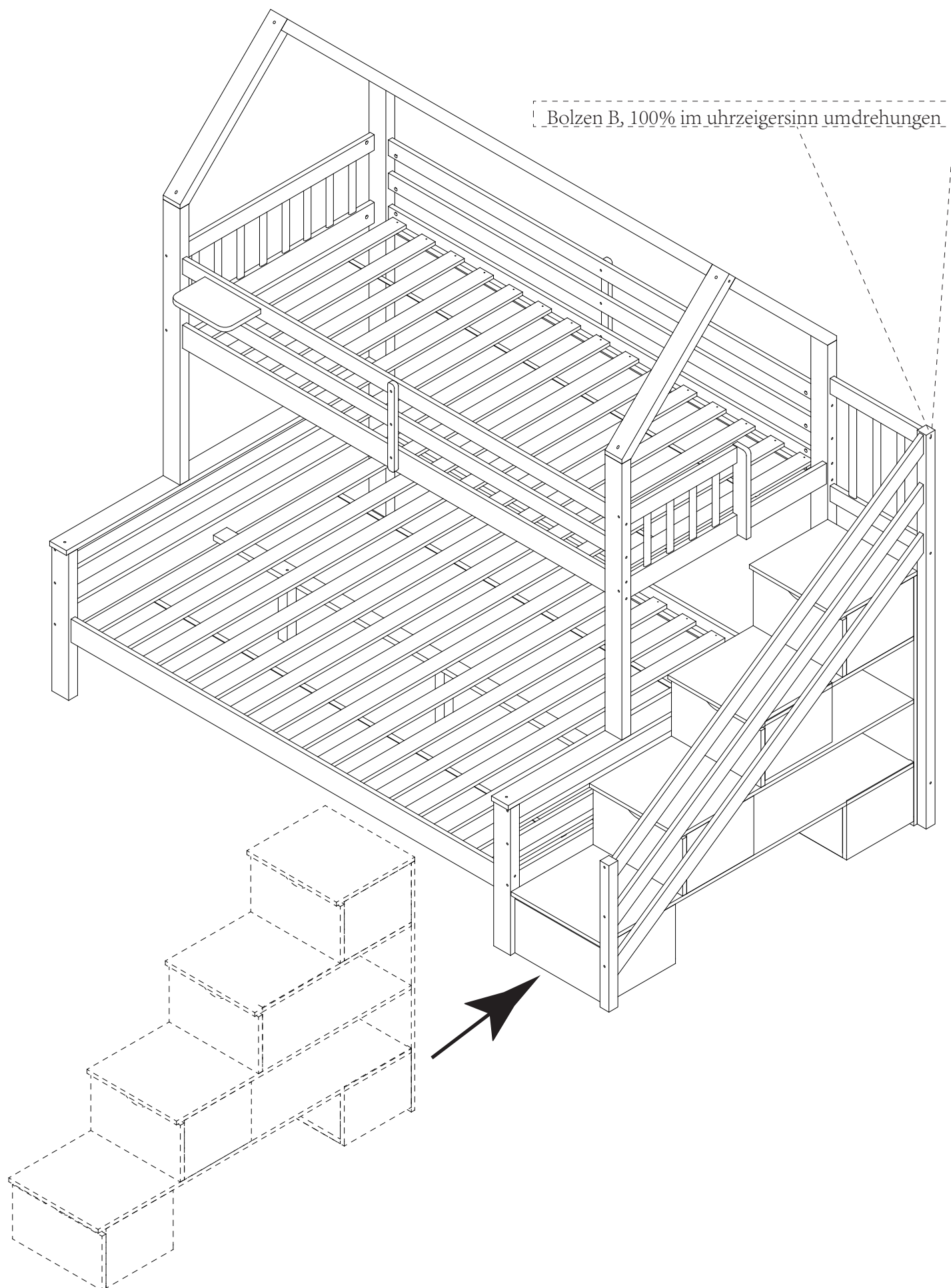

Schritt 29



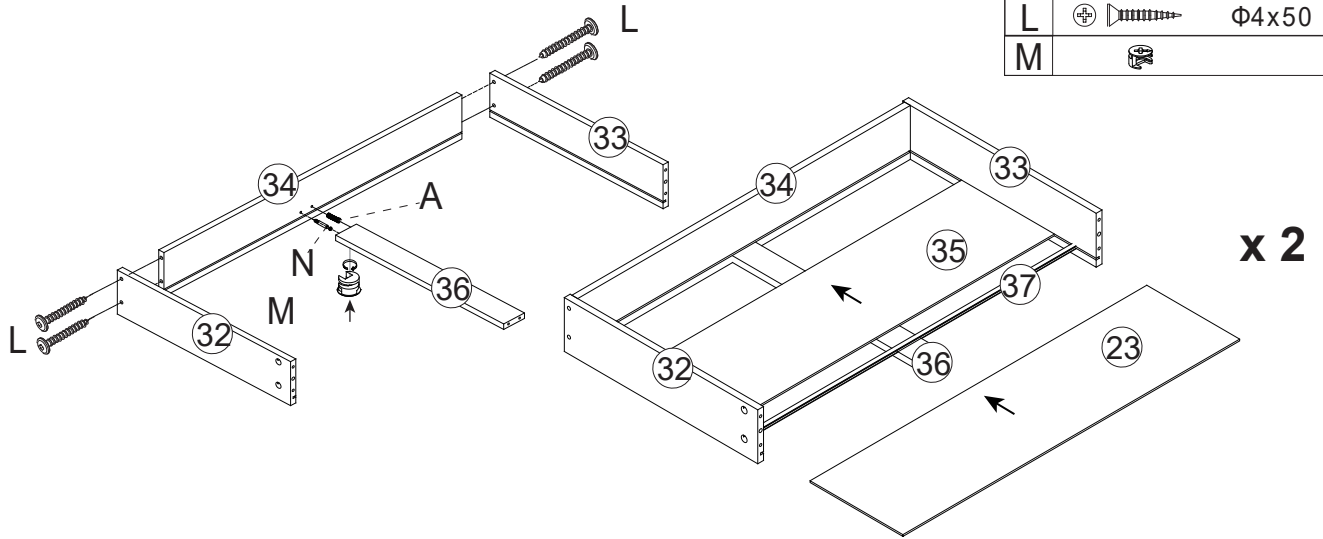

Schritt 30

A		Φ8x30	2
N			2
L		Φ4x50	8
M			2



Schritt 31

A		Φ8x30	6
N			10
M			10

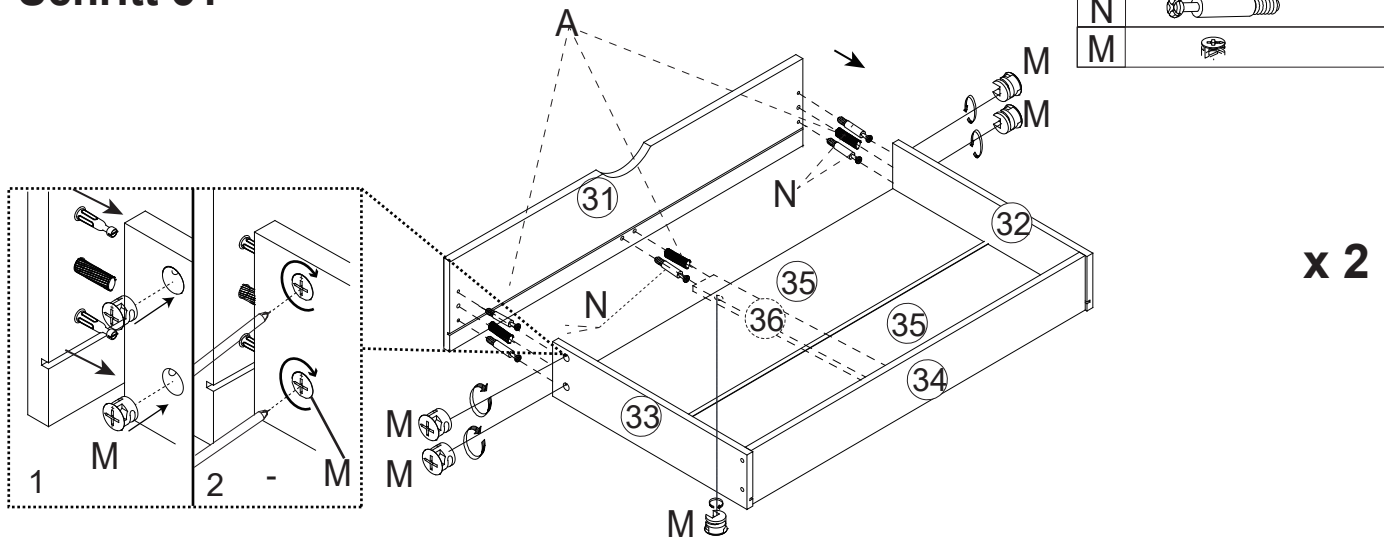

Schritt 32

I		Φ3.5x16	16
R			8

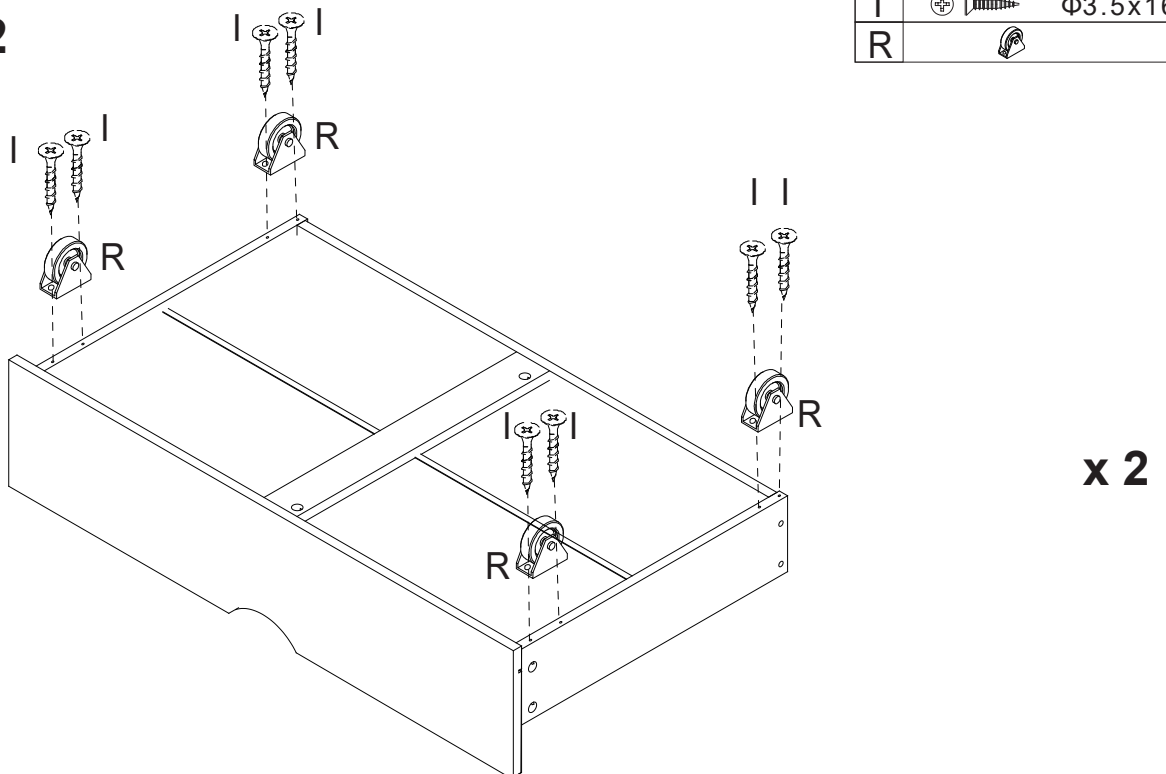

Schritt 33

