

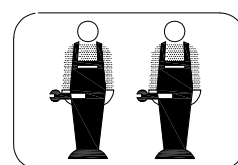

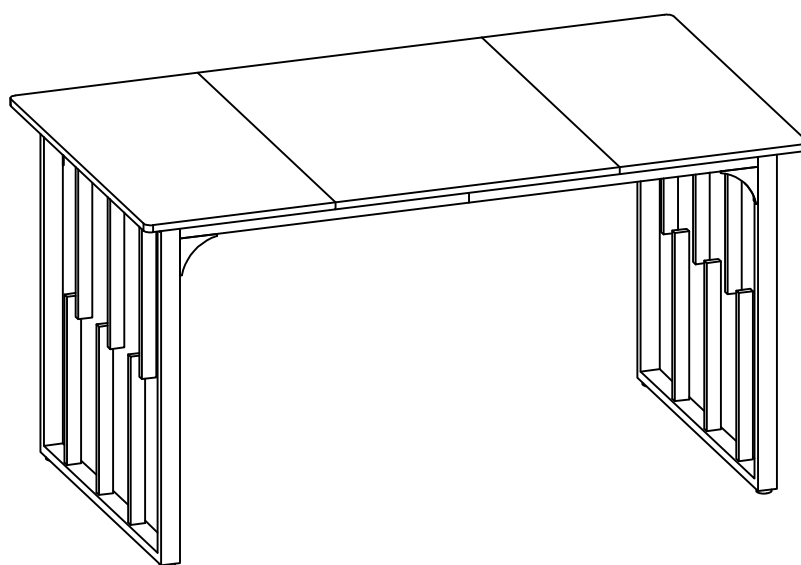

ASSEMBLY INSTRUCTIONS

MONTAGEANLEITUNGEN

WF319703



 M6×30mm	 M6×50mm	 M6×60mm
Ⓑ×12pcs	Ⓒ×8pcs	Ⓓ×4pcs

Bitte beachten Sie, dass die Formen der Schrauben B und C und D ähnlich sind. Bitte installieren Sie entsprechend der Anleitung und unterscheiden Sie sie!

Please note that the shapes of screws B and C and D are similar. Please install according to the instructions and distinguish them!

Notez que les vis B et C et D ont des formes similaires. Veuillez les installer en suivant les instructions pour les séparer!



Vor dem Einbau die Schrauben in die Löcher stecken und festziehen, aber nicht bis 100%, 70% bis 80% anziehen reicht aus. Schließlich, nachdem alle Schrauben installiert sind, ziehen Sie alle Schrauben auf 100%. Wenn Sie auf diese Probleme stoßen, z.B. wenn die Löcher nicht ausgerichtet werden können oder einige Teile nicht installiert werden können, überprüfen Sie bitte, ob die Schrauben korrekt verwendet werden und passen Sie die Dichtigkeit der Schrauben an.

Before installation, insert the screws into the holes and tighten them, but do not tighten them to 100%, 70% to 80% is sufficient. Finally, after all screws are installed, tighten all screws to 100%. If you encounter these issues, such as if the holes cannot be aligned or some parts cannot be installed, please check if the screws are used correctly and adjust the tightness of the screws.

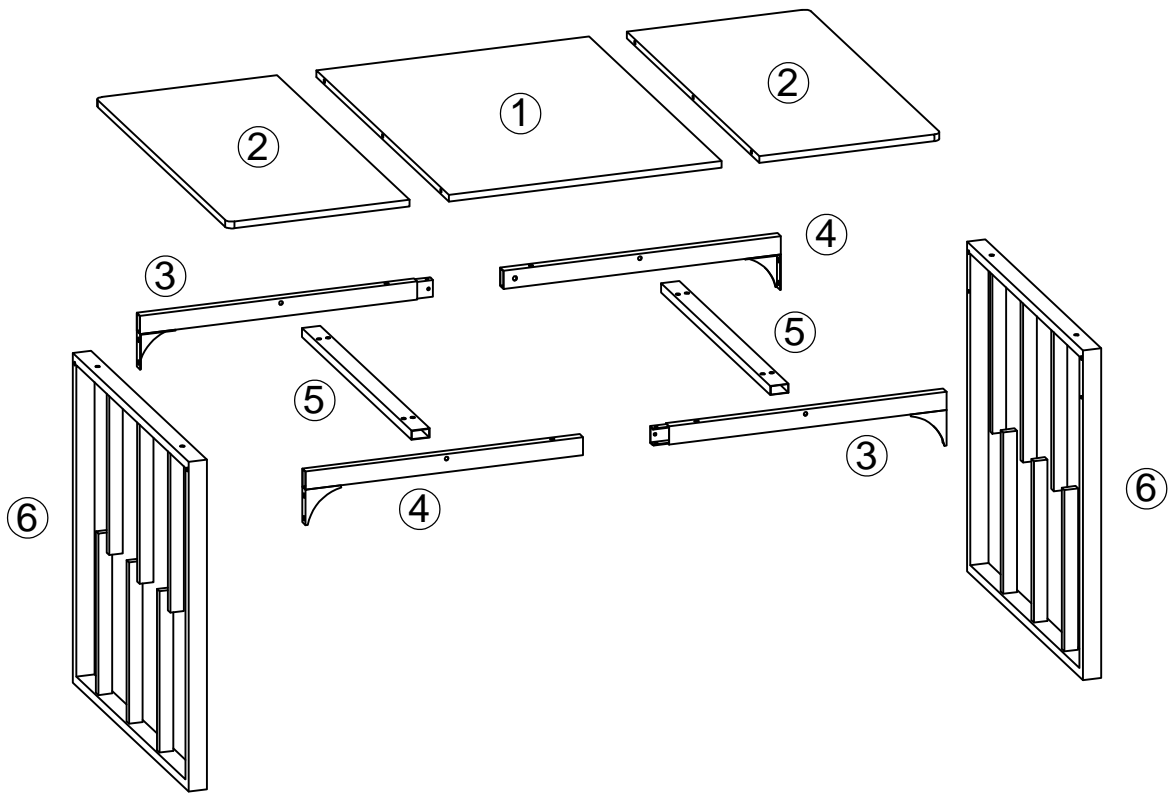



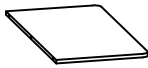

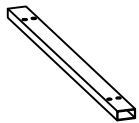
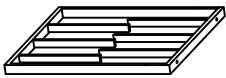
Insérer la vis dans le trou avant la fin de l'assemblage, serrer la vis, mais ne pas serrer à 100%, 70% ~ 80% est correct. Enfin, une fois que toutes les vis sont bien serrées, toutes les vis sont serrées à 100%. Si vous rencontrez ces problèmes, par exemple si les trous ne sont pas alignés ou si certaines pièces ne peuvent pas être montées, vérifiez que les vis sont utilisées correctement et Ajustez leur serrage.



Part List
Stückliste

			
①×1pc	②×2pcs	③×2pcs	④×2pcs
			
⑤×2pcs	⑥×2pcs		

Hardware List
Hardwareliste

 M6×12mm	 M6×30mm	 M6×50mm	 M6×60mm	
Ⓐ×8pcs	Ⓑ×12pcs	Ⓒ×8pcs	Ⓓ×4pcs	Ⓔ×6pcs
				
Ⓕ×4pcs	Ⓖ×1pc			

Step 1
Schritt 1



Ⓔ×6pcs

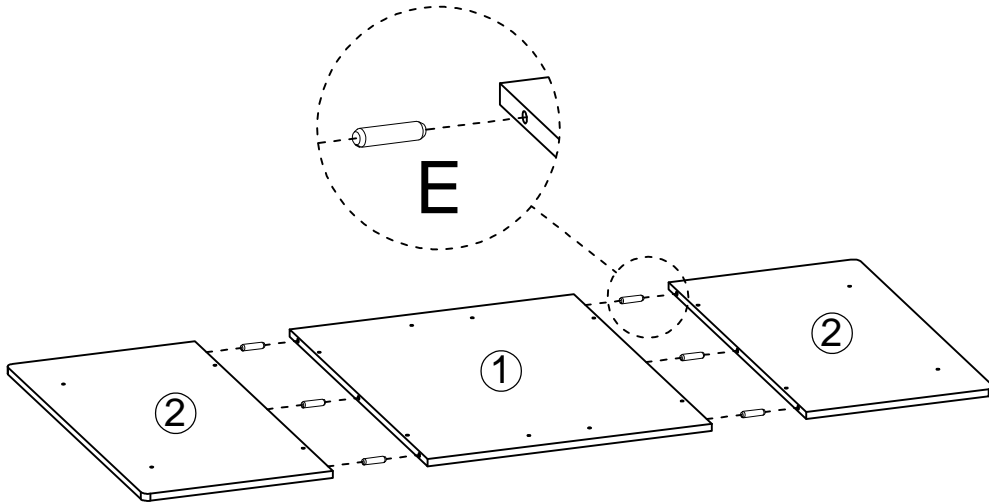

Step 2
Schritt 2



M6×12mm

Ⓐ×4pcs

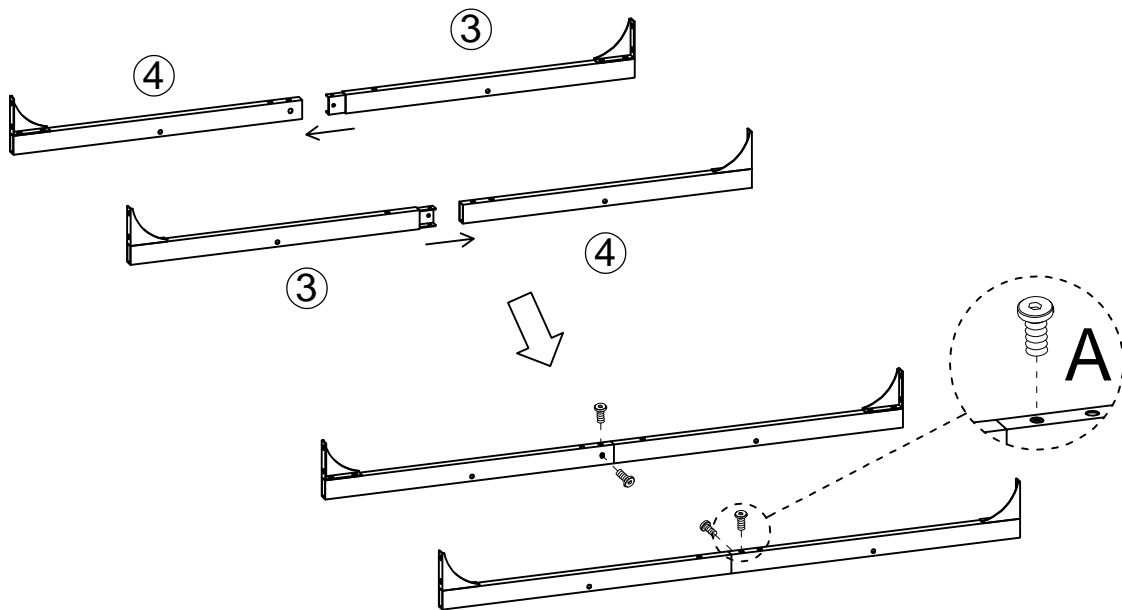

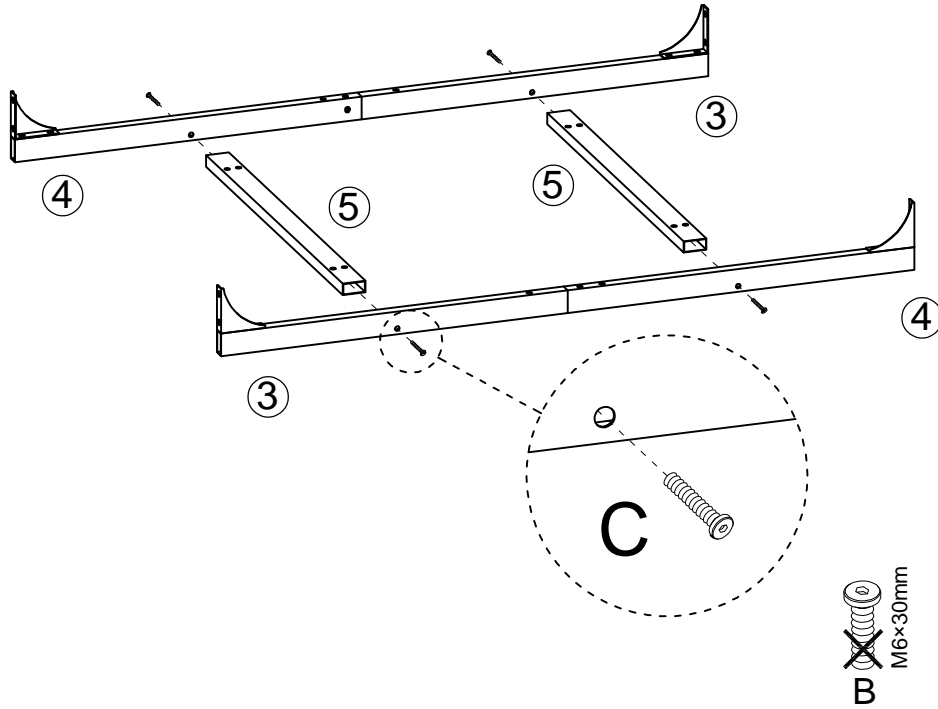
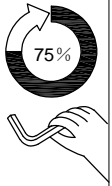

Step 3
Schritt 3

M6×50mm
Ⓒ ×4pcs





Step 4
Schritt 4

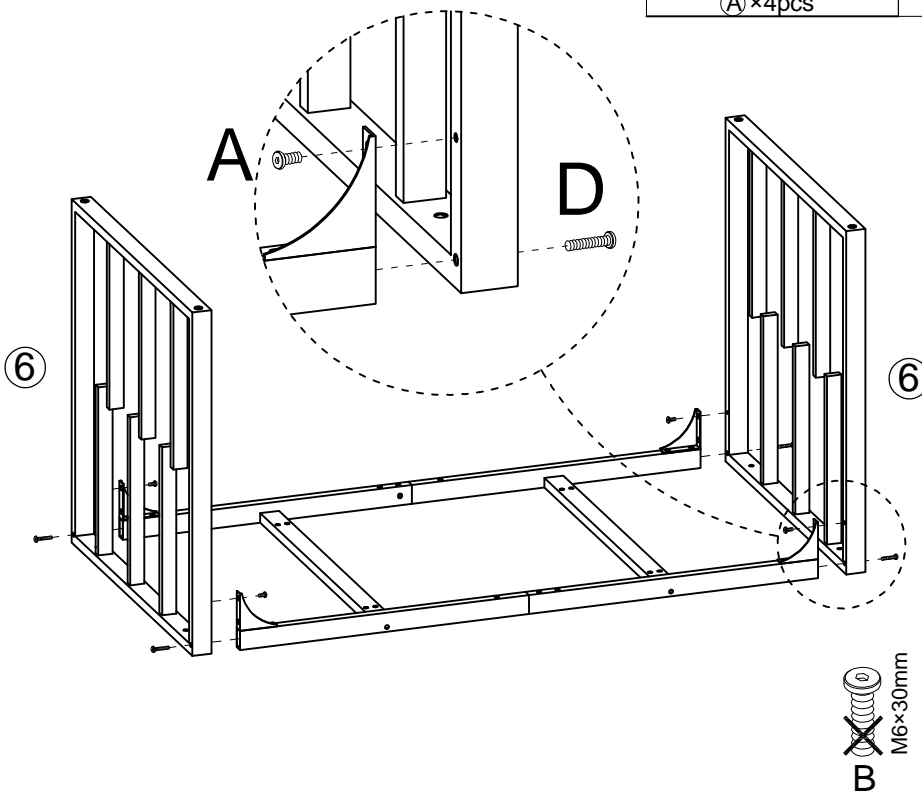
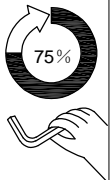

	
M6×12mm	M6×60mm
Ⓐ ×4pcs	Ⓓ ×4pcs

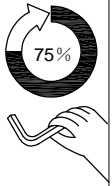
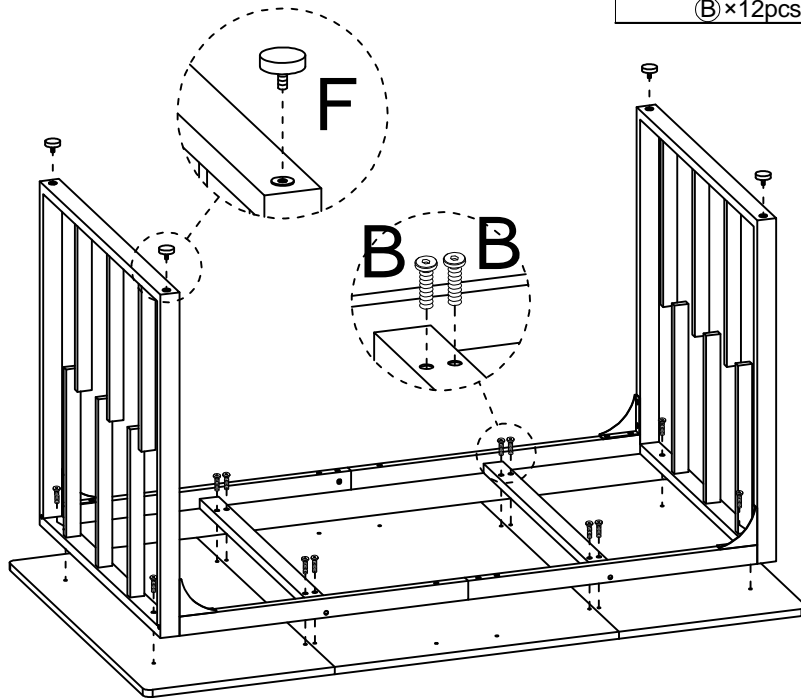

Step 5 Schritt 5

 M6×30mm	
(B)×12pcs	(F)×4pcs

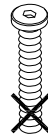

-  B M6×30mm
- ~~~~ C ~~M6×50mm~~
- ~~~~ D ~~M6×60mm~~

Step 6 Schritt 6

 M6×50mm
(C)×4pcs

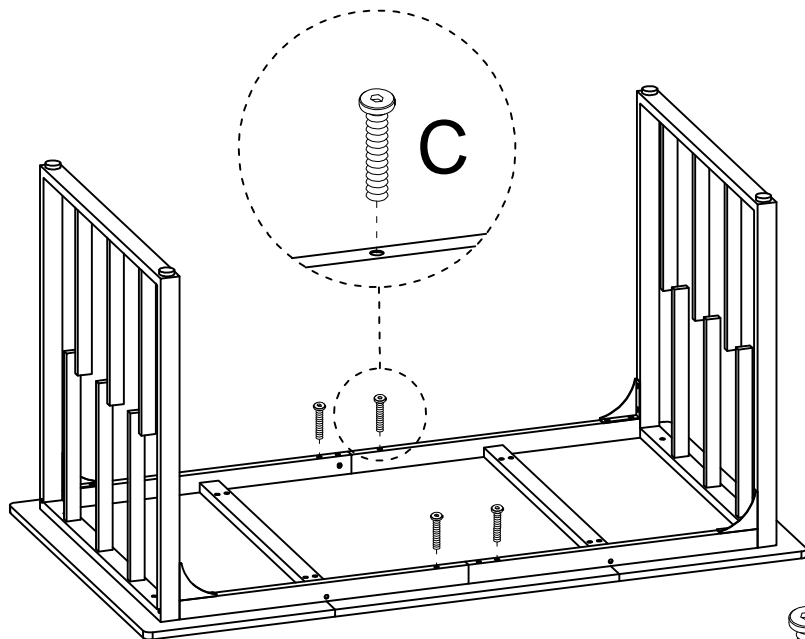

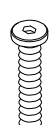
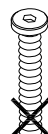
- ~~~~ B ~~M6×30mm~~
-  C M6×50mm
- ~~~~ D ~~M6×60mm~~

Step 7
Schritt 7

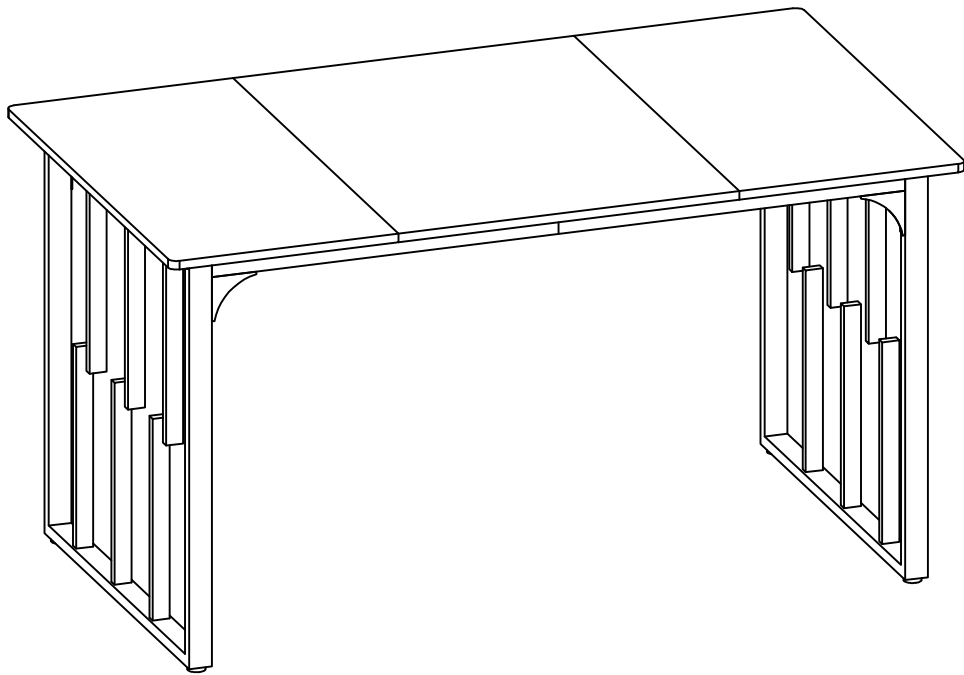

Anleitung

WF322897AAM

TIPPS

1. Wir danken Ihnen für den Einkauf! Wir bemühen uns, Ihnen qualitativ hochwertige Produkte zu bieten. In seltenen Fällen, dass Ihr Produkt beschädigt ist, Teile fehlt oder Sie auf Probleme bei der Montage stoßen, wenden Sie sich damit bitte an unseren Kundendienst, wir werden Ihnen die beste Lösung so schnell wie möglich bieten. Um Ihr Problem schnell zu lösen, bitte stellen Sie uns einige Bilder zur Verfügung, die das Produktproblem deutlich widerspiegeln können. Vielen Dank !

2. Vor dem Einbau die Schrauben in die Löcher stecken und festziehen, aber nicht bis 100%, 70% bis 80% anziehen reicht aus. Schließlich, nachdem alle Schrauben installiert sind, ziehen Sie alle Schrauben auf 100%.

Wenn Sie auf diese Probleme stoßen, wie z. B. Fehlausrichtung der Löcher oder Unfähigkeit, bestimmte Teile zu installieren, überprüfen Sie bitte, ob die Schrauben korrekt verwendet werden und passen Sie die Dichtigkeit der Schrauben an.

3. Es wird empfohlen, dass 2 Personen das Produkt installieren.

Assembly Instruction

WF322897AAM

Tips

1. Please read the instructions fully before assembly. These instructions include important information which could ensure correct assembly. We have been working on providing high quality products for you. However, in the rare instance that your product is defective, missing parts or there are some issues, please don't hesitate to contact our customer service to submit parts requirements, assembly suggestion, or warranty claims, and we will give the best solution as soon as possible. If necessary, we need you to provide some more clear pictures of the issue.

2. Before installation, insert the screws into the holes and tighten them, but do not tighten them to 100%, 70% to 80% is sufficient. Finally, after all screws are installed, tighten all screws to 100%.

If you encounter these issues, such as if the holes cannot be aligned or some parts cannot be installed, please check if the screws are used correctly and adjust the tightness of the screws.

3. 2 people are recommended to finish.

Le manuel d'emploi

WF322897AAM













Conseils

1. Veuillez lire attentivement les instructions avant le montage. Ces instructions contiennent des informations importantes qui pourraient garantir un montage correct. Nous avons travaillé pour vous fournir des produits de haute qualité. Cependant, dans les rares cas où votre produit est défectueux, s'il manque des pièces ou s'il y a des problèmes, n'hésitez pas à contacter notre service client pour soumettre des exigences de pièces, des suggestions d'assemblage ou des réclamations de garantie, et nous vous donnerons la meilleure solution comme dès que possible. Si nécessaire, nous avons besoin que vous fournissiez des images plus claires du problème.

2. Insérer la vis dans le trou avant la fin de l'assemblage, serrer la vis, mais ne pas serrer à 100%, 70% ~ 80% est correct. Enfin, une fois que toutes les vis sont bien serrées, toutes les vis sont serrées à 100%.

Si vous rencontrez ces problèmes, par exemple si les trous ne sont pas alignés ou si certaines pièces ne peuvent pas être montées, vérifiez que les vis sont utilisées correctement et ajustez leur serrage.

3. Deux personnes sont recommandées pour le terminer.

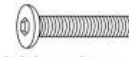
1  x1	2  x1	3  x1	4  x1	5  x1	6  x1	7  x1
A  x1	B  x2	C  x14	D  x2	E  x8	F  x4	G  x2

Schritt:1

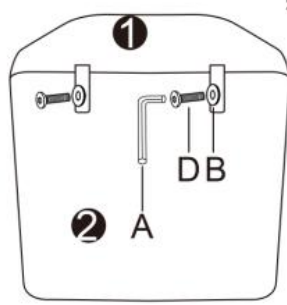

M6x13mm ~~X~~ M6x20mm ~~X~~ M6x30mm ~~X~~ M6x40mm ~~X~~

Schritt:2



M6x13mm ~~X~~ M6x20mm ~~X~~ M6x30mm ~~X~~ M6x40mm ~~X~~

Schritt:3

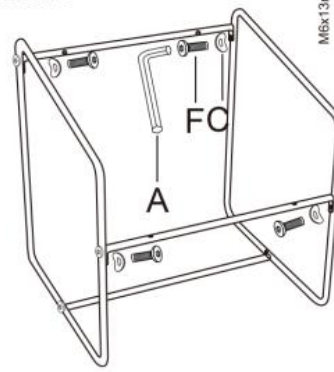

M6x13mm ~~X~~ M6x20mm ~~X~~ M6x30mm ~~X~~ M6x40mm ~~X~~

Schritt:4



M6x13mm ~~X~~ M6x20mm ~~X~~ M6x30mm ~~X~~ M6x40mm ~~X~~

Schritt:5

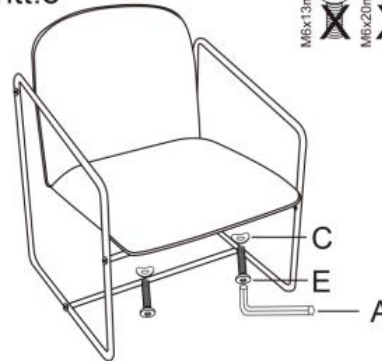

M6x13mm ~~X~~ M6x20mm ~~X~~ M6x30mm ~~X~~ M6x40mm ~~X~~

Schritt:6



1. Bitte beachten Sie, dass die Formen der Schrauben D und E und F und G ähnlich sind. Bitte installieren Sie entsprechend der Anleitung und unterscheiden Sie sie!

2. Please note that the shapes of screws D and E and F and G are similar. Please install according to the instructions and distinguish them!

3. Notez que les vis D et E et F et G ont des formes similaires. Veuillez les installer en suivant les instructions pour les séparer!