



Art.Nr.:LEU-LED-000180



ta.max.85°C

12VDC

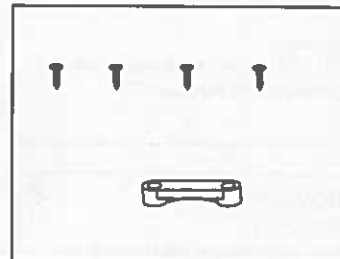
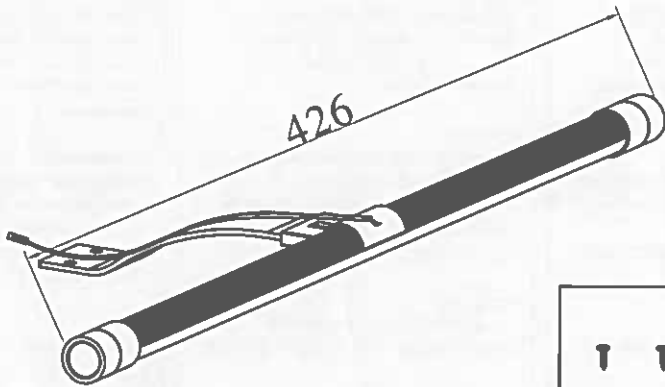

1

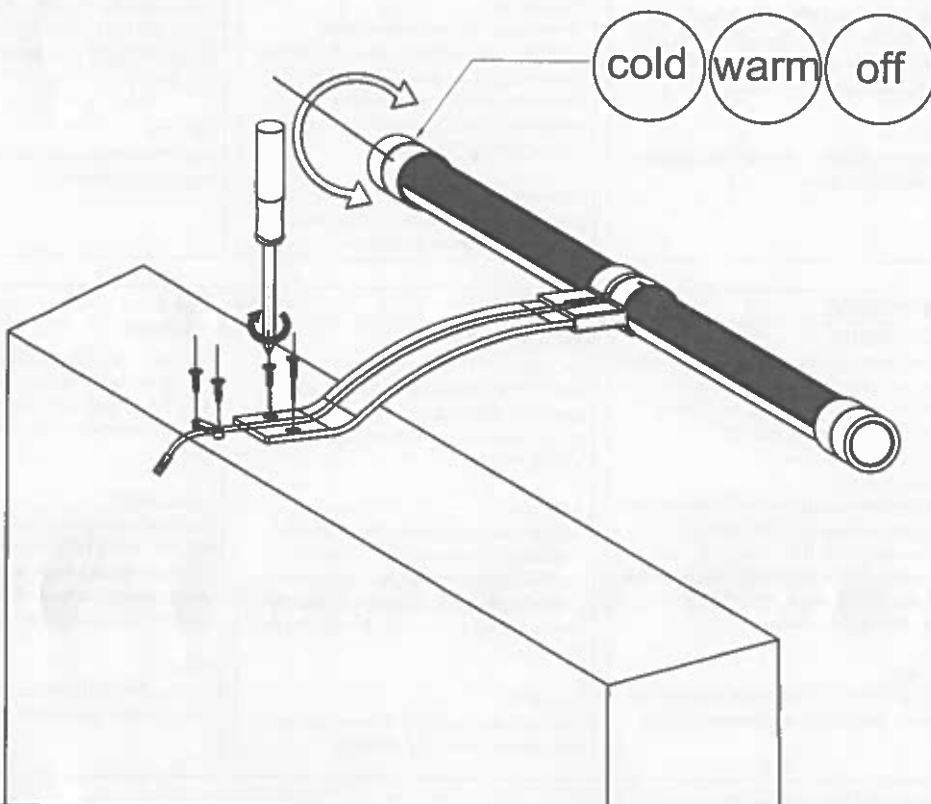

2

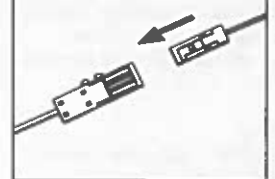

DEUTSCH (DE)
WICHTIG!
 Die Installation sollte von einem qualifizierten Elektriker durchgeführt werden. Die Leuchte muss fest im elektrischen System installiert sein.

Achtung!
 Die Lichtquelle dieses Produkts besteht aus nicht austauschbaren Leuchtdioden(LED). Das Produkt nicht auseinander nehmen, da die Leuchtdioden die Augen ohne Abdeckung schädigen können. Nicht in Wasser tauchen.

Reinigung
 Mit einem feuchten Tuch reinigen. Keine starken Reinigungsmittel verwenden.

ENGLISH (GB)
IMPORTANT!
 The installation shall be carried out by an authorised electrical contractor. The luminaire must be permanently installed in the electric system and placed in the correct zone.

Caution!
 The light source of this product is non-changeable light diodes (LED). Do not disassemble the product, as the light diodes can cause damage to the eyes. Do not immerse in water.

Cleaning
 Use a damp cloth, never a strong cleaning agent.

ITALIANO (IT)
IMPORTANTE!
 L'installazione deve essere eseguita da un elettricista autorizzato. Questa illuminazione richiede un'installazione fissa nel sistema elettrico e deve essere collocata nella zona corretta.

Avvertenza!
 La fonte luminosa di questo prodotto è costituita da diodi a emissione luminosa (LED) non sostituibili. Non smontare il prodotto perché i diodi possono danneggiare gli occhi. Non immergere nell'acqua.

Pulizia
 Usa un panno umido ed evita i detersivi forti. verwenden.

FRANÇAIS (FR)
ATTENTION!
 L'installation doit être effectuée par un Électricien qualifié. Le luminaire doit être branché de manière permanente au système électrique et placé dans la zone adéquate.

Mise en garde
 La source lumineuse du produit est composée de diodes (LED) qui ne se remplacent pas. Ne jamais démonter le produit, les diodes peuvent causer des blessures aux yeux. Ne jamais immerger dans de l'eau.

Entretien
 Nettoyer à l'aide d'un chiffon humide, éviter les détergents puissants.

POLSKI (PL)
WAŻNE!
 Montaż w łazience powinien przeprowadzić uprawniony elektryk. Urządzenie świetlne musi zostać zainstalowane na stałe w systemie elektrycznym i znajdować się we właściwym miejscu.

Uwaga!
 Źródłem światła w tym urządzeniu są niewymienne diody LED. Urządzenia nie wolno rozbrajać, ponieważ diody mogą spowodować uszkodzenie oczu. Nie zanurzaj w wodzie.

Czyszczenie
 Czyść wyłącznie wilgotną szmatką, nigdy nie stosuj silnych środków czyszczących.

MAGYAR (HU)
FONTOS!
 A szerelvényezést csak szakember végezheti. A világító testeket folyamatosan kell az elektromos rendszerbe bekötni, és a megfelelő helyre tenni.

Figyelem!
 A termék fényforrása nem cserélhető világító diódák (LED). Ne szereld szét a terméket, mivel a diódák szemkárosodást okozhatnak! Ne tedd vízbe a terméket!

Tisztítás:
 Nedves ruhával tisztíthatod, soha ne használd erős tisztítószert!

SVENSKA (SE)
VIKTIG!
 Installationen skall utföras av en behörig ellinstallatör. Belysningen kräver fast installation och måste placeras i rätt zon.

Varning!
 Ljuskällan till denna produkt är ej utbytbara lysdioder (LED). Produkten får inte tas isär, eftersom lysdioderna kan försäkra ögonskador. Får inte sänkas ner i vatten.

Rengöring
 Använd en fuktig trasa, undvik användning av starkt rengöringsmedel.

РУССКИЙ (RU)
ВНИМАНИЕ!
 Установку должен производить квалифицированный электрик. Светильник должен быть постоянно встроен в электрическую систему и правильно размещен.

Осторожно!
 Источник света данного изделия – светодиоды, не подлежащие замене (LED). Не разбирайте изделие, так как светодиоды могут повредить зрение. Не погружать в воду.

Уход
 Протирайте влажной тканью, не используйте сильное чистящее средство.

SLOVENŠČINA (SI)
POMEMBNO!
 Namestitev naj opravi kvalificiran električar. Svetilka mora biti fiksno vezana na električno omrežje in postavljena na ustrezno mesto.

OPOZORILO!
 Vir svetlobe pri tem izdelku so LED-diodi, ki niso zamenljive. Izdelka ne razstavljajte, saj lahko diode povzročijo poškodbe oči. Ne namakajte v vodo.

Čiščenje
 Uporabite le vlažno krpo, nikoli močnega čistilnega sredstva.

ROMÂNĂ (RO)
ATENȚIE!
 Instalarea trebuie efectuată de un instalator autorizat. Corpul de iluminat trebuie să fie în permanență instalat în sistemul electric și așezat în zona adecvată.

Atenție!
 Sursa de lumină a acestui produs este LED. Nu desassemble produsul, întrucât lumina diodei poate afecta vederea. Nu scufunda în apă.

Curățare
 Folosește o cârpă umeză, niciodată un detergent puternic.

БЪЛГАРСКИ (BG)
ВАЖНО!
 Монтажът трябва да се извърши единствено от оторизиран електротехник. Лампата трябва да бъде неподвижно свързана с електрическата мрежа и правилно разположена.

Внимание!
 Източникът на светлина в този продукт са неподменяеми светлинни диоди (LED). Не разглобявайте продукта, тъй като светлинните диоди могат да увредят очите ви. Не потапяйте във вода.

Почистване
 Използвайте влажна кърпа, никога силен почистващ препарат.

HRVATSKI (HR)
VAŽNO!
 Instalaciju mora obaviti ovlaštenu električar. Lampa se trajno spaja u strujnu mrežu i postavlja na točno određeno mjesto.

Oprez!
 Izvor su svjetla ovog proizvoda svjetlosne diode (LED) koje se ne mogu mijenjati. Ne rastavljajte ovaj proizvod jer svjetlosne diode mogu oštetiti vid. Ne uranjajte u vodu.

Čišćenje
 Koristite vlažnu krpu, nikad jako sredstvo za čišćenje.

SLOVENSKY (SK)
Dôležitá!
 Inštalácia musí byť prevedená kvalifikovaným elektrikárom. Osvetlenie musí byť v elektrickom systéme nainštalované trvale a v správnej zóne.

Upozornenie.
 Svetelným zdrojom pre tento produkt sú svetelné diódy (LED), ktoré sa nedajú vymieňať. Produkt nerozoberajte, svetelné diódy môžu spôsobiť poškodenie zraku. Neponárajte do vody.

Údržba
 Čistite vlhkou handrou, nikdy nie agresívnym čistiacim prostriedkom.

NEDERLANDS (NL)
BELANGRIJK!
 De installatie dient te worden uitgevoerd door een elektricien. De verlichting vereist vaste installatie en moet in de juiste zone worden geplaatst.

Waarschuwing!
 De lichtbron van dit product bestaat uit niet-vervangbare lichtdioden (LED). Het product mag niet uiteen worden genomen, omdat de lichtdioden oogletsel kunnen veroorzaken. Niet onderdompelen in water.

Reinigen
 Gebruik een vochtig doekje, vermijd het gebruik van sterke reinigingsmiddelen.

ESPAÑOL (ES)
IMPORTANTE!
 La instalación debe realizarla un electricista profesional. La lámpara debe instalarse conectada de modo permanente al sistema eléctrico y en la zona correcta.

Atención!
 La fuente luminosa de este producto son diodos luminicos (LED) que no pueden reemplazarse. No desmontes el producto; los diodos luminicos pueden causar daños en los ojos. No losumerjas en agua.

Limpieza
 Usa un trapo húmedo. Nunca uses un detergente fuerte. verwenden.

ČESKY (CZ)
Důležité!
 Instalace musí být provedena kvalifikovaným elektrikářem. Osvětlení musí být v elektrickém systému instalováno trvale a umístěno do správné zóny.

Upozornění!
 Světelným zdrojem tohoto výrobku jsou světelné diody (LED), které nelze vyměnit. Výrobek nerozebírejte, protože světelné diody by vám mohly poškodit zrak. Výrobek neponořujte do vody.

Čištění
 Otřete vlhkým hadříkem, zásadně nepoužívejte silné čisticí prostředky.

EASY bath

MADE IN ITALY



Eureka srl
 Via Veneto, 20-22
 31040 Gorgo al Monticano
 (Treviso) Italy
 Tel. +39 0422 8004
 Fax +39 0422 800501
 info@eurekatala.it
 www.eurekatala.it

ANLEITUNG / INSTRUCTIONS / ISTRUZIONI / INSTRUCTIONS / INSTRUCCIONES

648AKXIF000005_ROO

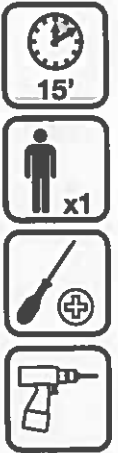
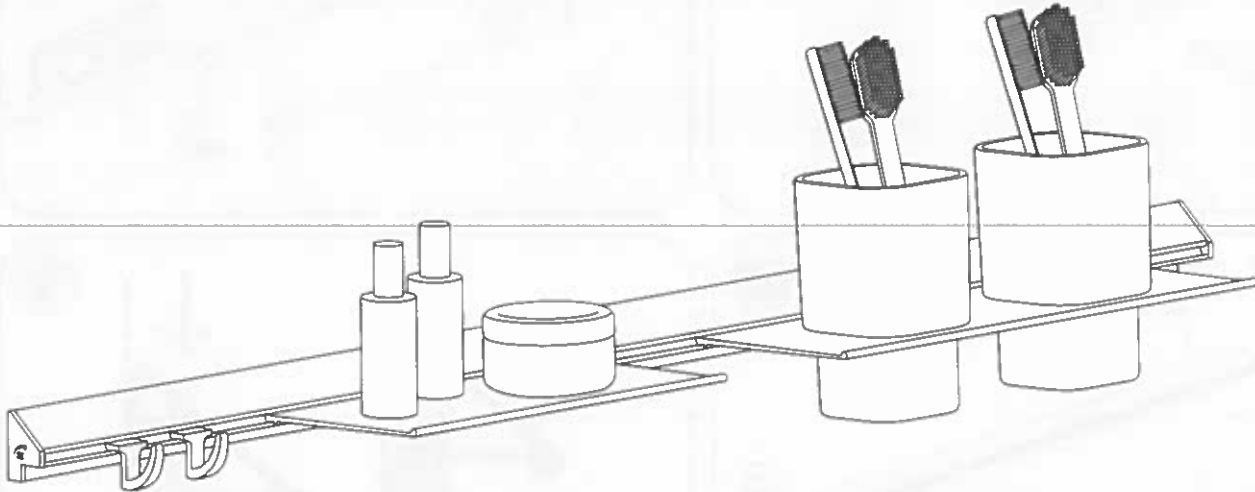

Die repräsentative Abbildung des Produktes ist rein indikativ - Images are only indicative
 L'immagine rappresentativa del prodotto è puramente indicativa

80 cm

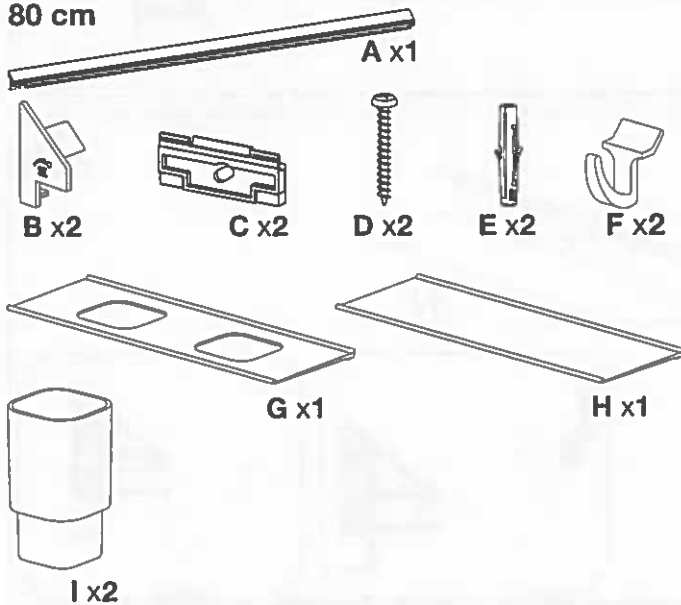

50 cm

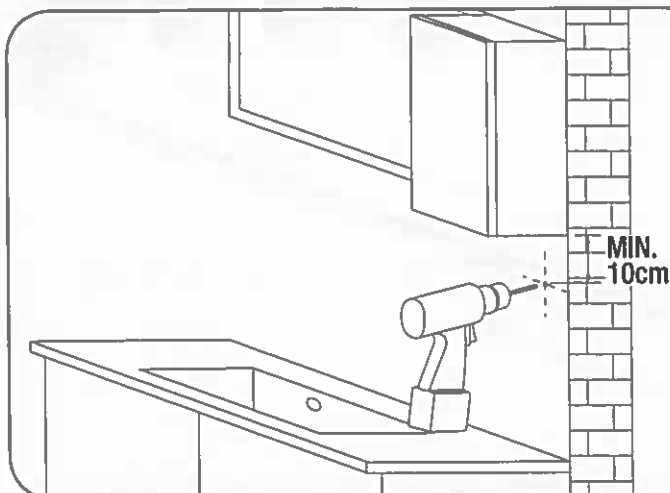
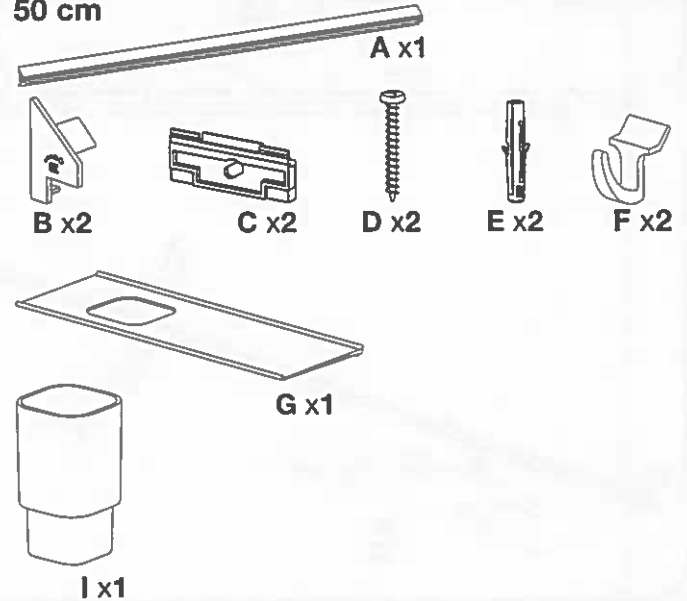

1

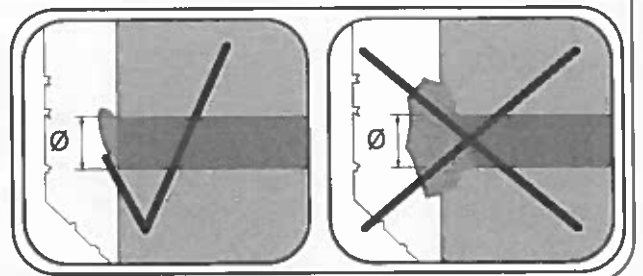

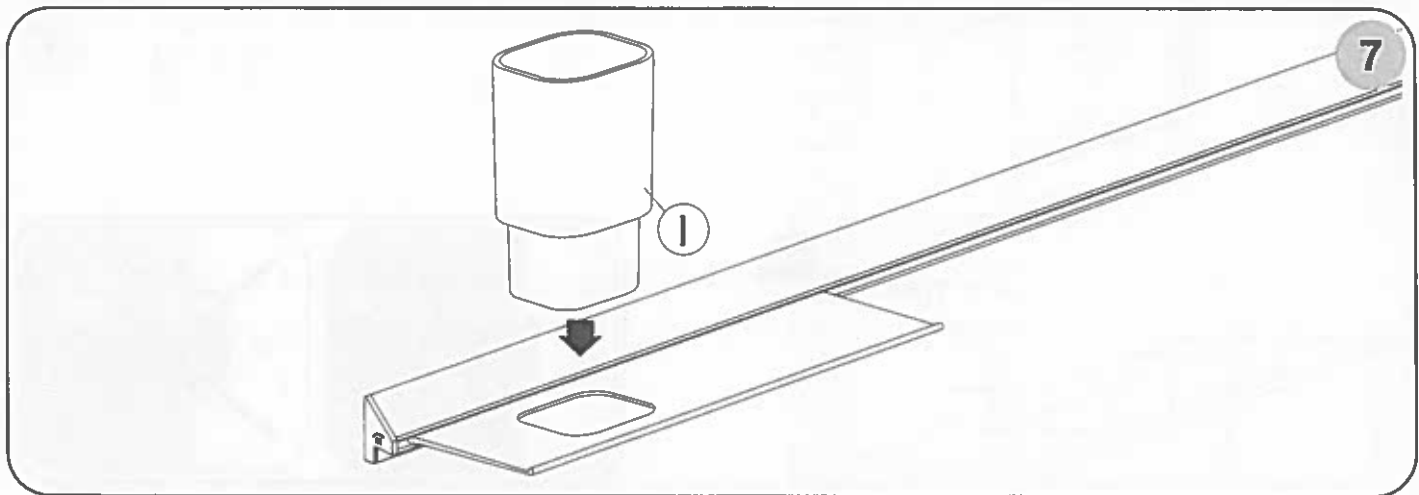
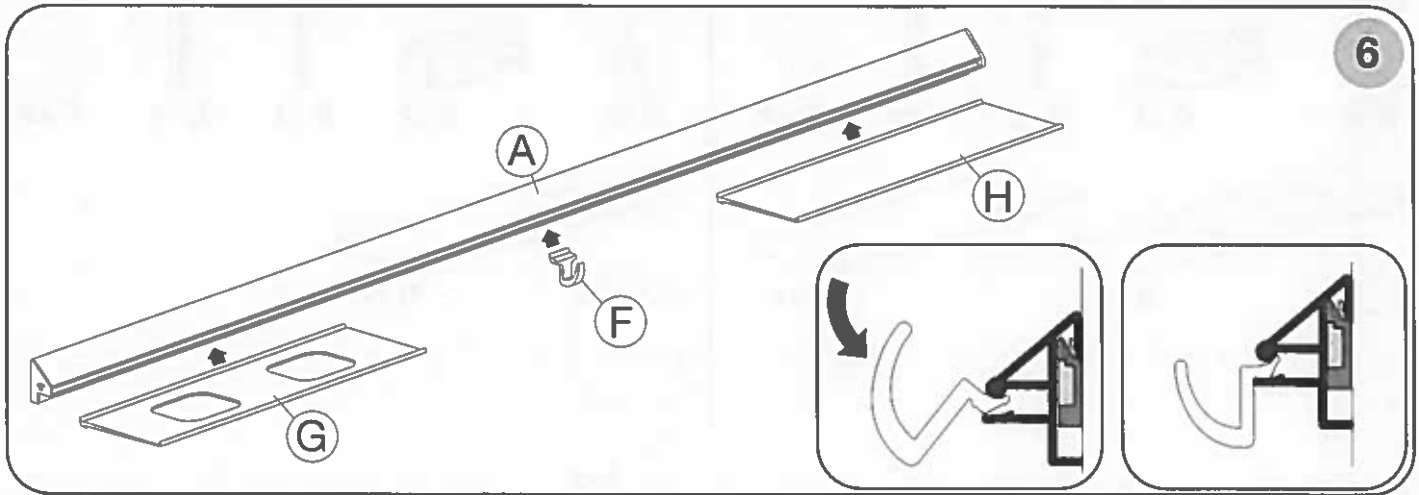
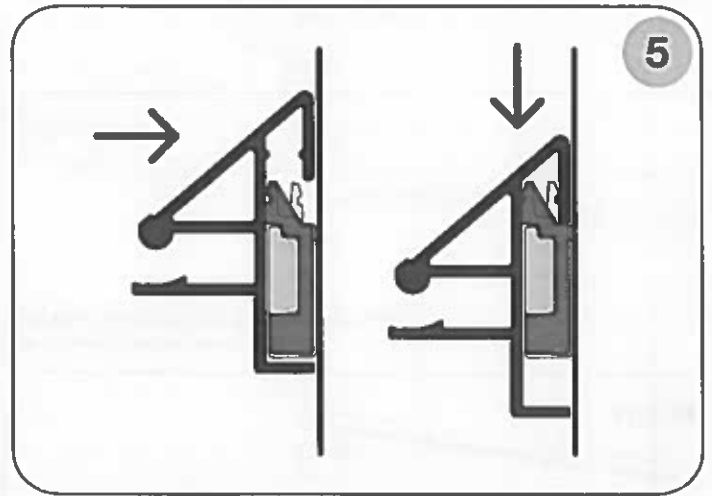
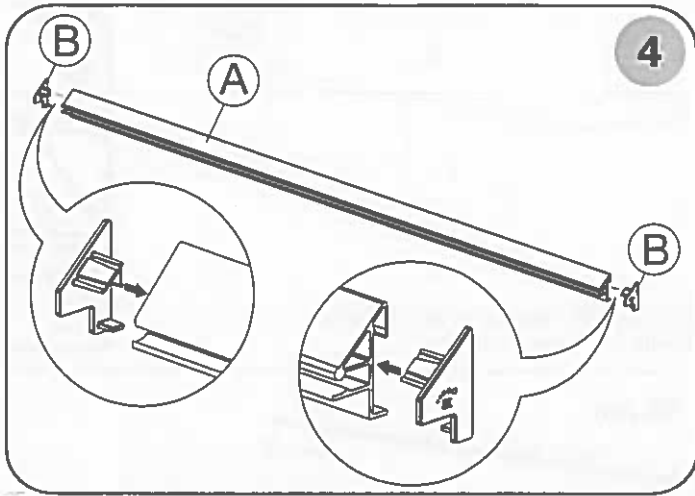
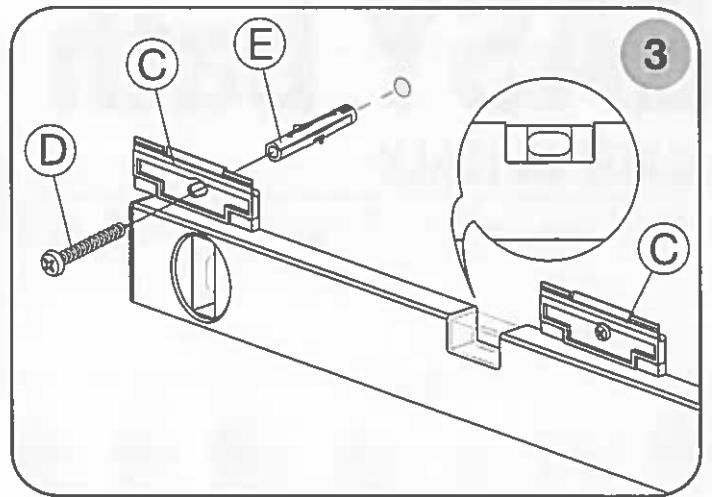
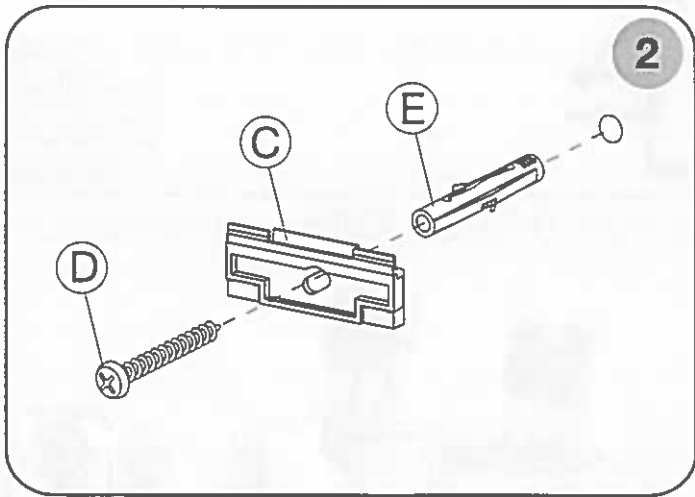

PL - Instrukcja montażu

Opis ogólny
Producent nie ponosi żadnej odpowiedzialności za uszkodzenia spowodowane niewłaściwym użytkowaniem wyrobu, zmianą konstrukcyjną, stosowanie nieodpowiednich elementów, oraz nieprzestrzeganie niniejszej instrukcji.

Warunki bezpieczeństwa

Przełącznik przeznaczony jest do użytku wewnątrz pomieszczeń i wykonany został na napięcie bezpieczne 12VDC. Sumaryczna moc podłączonych opraw LED nie może przekraczać znamionowej mocy przełącznika. Parametry techniczne wyszczególnione są na etykiecie produktu. Montaż wykonać zgodnie z zaleceniami instrukcji montażu. Podczas montażu przełącznik nie może być podłączony do źródła prądu. Do czyszczenia należy stosować wyłącznie delikatne, suche tkaniny, nie należy stosować środków czyszczących. W przypadku jakichkolwiek wątpliwości należy skontaktować się ze specjalistą. Podczas nie używania urządzenia przez dłuższy czas, w celu oszczędności energii elektrycznej należy odłączyć od sieci układ zasilający.

Zastosowanie

Przełącznik dotykowy przeznaczony jest do załączania i wyłączania oświetlenia LED stosowanego do płyty meblowej. Przełącznik należy stosować do w miejscu które pozostawiane jest materiału odbijającego. Dopuszczalna grubość płyty max 30 mm.

Dane techniczne

Napięcie zasilania	: 12 VDC
Napięcie wyjściowe	: 12 VDC
Klasa ochrony	: III
Stopień ochrony	: IP 20
Moc	: 50 W
Prąd maksymalny	: 4,16 A
Zakres pracy	: max 30 mm

Montaż

- W miejscu montażu przełącznika powierzchnia płyty musi być czysta i sucha
- Zerwać papier zabezpieczający taśmę klejącą.
- Przymocować przełącznik w wybranym miejscu.
- Do złącza oznaczonego "OUTPUT" podłączyć oświetlenie LED.
- Do złącza oznaczonego "INPUT" podłączyć zasilanie 12VDC.
- Sprawdzić poprawność montażu i połączeń

UWAGA - KALIBRACJA

Przełącznik należy nakleić na płytę w docelowym miejscu przed podłączeniem zasilania. Podczas załączania zasilania nie należy dotykać przełącznika lub trzymać go w dłoni, ponieważ przeprowadzana jest autokalibracja do danego podłoża. W przeciwnym wypadku przełącznik może nie działać prawidłowo.

EN - Installation

General Description
The manufacturer assumes no responsibility for any damage caused by improper use of the product, the design changes, the use of unsuitable items, and failure of this manual.

Safety

- The switch is designed for indoor use and is made safe 12VDC voltage.
- The total connected lighting power LED does not exceed the rated output of the switch. Specifications are listed on the product label.
- Mounting options recommended installation instructions.
- When installing the switch can not be connected power source.
- When cleaning, use only soft, dry cloth, do not use cleaning agents.
- In case of any doubt, contact a professional. When not used for a long period of time, in order to conserve energy, unplug the power supply system.

Application

Touch switch is designed for switching on and off of LED lighting used to illuminate the wood. The switch should be used in place of a wood that is deprived of reflective material. Permissible thickness of max 30 mm wood.

Specifications

Supply voltage	: 12 VDC
Output voltage	: 12 VDC
Protection class	: III
Degree of protection	: IP 20
Power	: 50 W
Maximum current of	: 4.16 A
Range	: max 30 mm

Assembly

- The place of installation switch plate surface must be clean and dry
- Peel off the protective paper tape.
- Connect the switch to the desired location.
- The connector labeled "OUTPUT" connect the LED lighting.
- The connector labeled "INPUT" Connect the 12VDC power supply.
- Check mounting and connections.

D - Installationsanleitung

Allgemeine Beschreibung
Der Hersteller übernimmt keine Verantwortung für S.C. häden, die durch unsachgemäßen Gebrauch des Produktes, die Design-Änderungen, die Verwendung ungeeigneter Produkte und Scheitern dieser Bedienungsanleitung verursacht.

Sicherheit

- Der Schalter ist für den Innenbereich konzipiert und wird sicher gemacht 12VDC Spannung. Die gesamte angeschlossene Beleuchtung Power-LED nicht mehr als die Nennleistung des Schalters. Daten werden auf dem Etikett aufgeführt. Montage Optionen empfohlen Installation anweisungen.
- Bei der Installation der Schalter kann nicht an eine Stromquelle angeschlossen werden. Bei der Reinigung, verwenden Sie nur weiches, trockenes Tuch, verwenden Sie keine Reinigungsmittel. Im Falle von Zweifeln, wenden Sie sich an einen Fachmann. Wenn nicht für eine lange Zeit verwendet, um Energie zu sparen, ziehen Sie das Netz.

Anwendung

Berührungsschalter ist zum Ein- und Ausschalten der LED-Beleuchtung verwendet werden, um die Holzfürmier. Der Schalter sollte anstelle von einem Holzfürmier, der aus reflektierendem Material entzogen wurde, verwendet werden. Zulässige Dicke von max 30 mm Holzfürmier.

Technische Daten

Versorgungsspannung	: 12 VDC
Ausgangsspannung	: 12 VDC
Schutzklasse	: III
Schutzart	: IP 20
Leistung	: 50 W
Maximalen Strom von	: 4,16 A
Range	: max 30 mm

Montage

- An die Stelle des Schalters Montageplatte Oberfläche muss sauber und trocken sein
- Ziehen Sie die Schutzfolie Lochtreffen. Schließen Sie den Schalter auf die gewünschte Position. Der Anschluss mit der Bezeichnung "OUTPUT" verbinden Sie das LED-Beleuchtung. Der Anschluss mit der Bezeichnung "INPUT" Schließen Sie die 12VDC Stromversorgung. Prüfen Sie, Montage und Anschlüsse.

CZ - Návod k instalaci

Obecný popis

Výrobce nenese žádnou odpovědnost za případné škody způsobené nesprávným používáním výrobku, konstrukční změny, použití nevhodných předmětů, a selhání tohoto návodu.

Bezpečnost

- Přepínač je určen pro vnitřní použití a je vyrobena bezpečně 12VDC napětí.
- Celkový přípojný světelný výkon LED nepřesahuje jmenovitý výkon přepínače. Specifikace jsou uvedeny na etiketě výrobku.
- Možností montáže doporučujeme montážní návod.
- Při instalaci přepínače nelze připojit ke zdroji napájení.
- Při čištění používejte pouze měkký, suchý hadřík. nepoužívejte čisticí prostředky.
- V případě jakýchkoli pochybností, kontaktujte odborníka. Nepoužívejte-li po delší dobu, aby ušetřili energii, odpojte napájecí systém.

Aplikace

Dotykový spínač je určen ke spínání a vypínání LED osvětlení slouží k osvětlení dřeva. Spínač by měl být použit v místě dřeva která je zbarvena reflexního materiálu.

Specifikace

Napájecí napětí	: 12 VDC
Výstupní napětí	: 12 VDC
Třída ochrany	: III
Stupeň ochrany	: IP 20
Výkon	: 50 W
Maximální proud	: 4,16 A
Rozsah	: max 30 mm

Montáž

- Na místě spínače montážní povrch desky musí být čistý a suchý
- Odlepte ochrannou papírovou pásku.
- Připojte přepínač do požadované polohy.
- Konektor označený "OUTPUT" připojí LED osvětlení
- Konektor označený "INPUT" Připojení 12VDC napájení
- Zkontrolujte montáž a připojení.

SK - Návod na inštaláciu

Všeobecný popis

Výrobca nenese žiadnu zodpovednosť za prípadné škody spôsobené nesprávnym používaním výrobku, konštrukčné zmeny, použitie nevhodných položiek, a neúspech v tejto príručke.

Bezpečnosť

- Prepínač je určen pre vnútorné použitie a je vyrobena bezpečně 12VDC napětí. Celkový přípojný světelný výkon LED nepřesahuje jmenovitý výkon přepínače. Specifikace sú uvedené na etikete výrobku. Možnosť montáže odporúčame montážny návod. Pri inštalácii prepínača nemožno pripojiť k zdroju napájania. Pri čistení používajte iba jemnú, suchú handričku, nepoužívajte čistiace prostriedky. V prípade akýchkoľvek pochybností, kontaktujte odborníka. Ak nepoužívate po dlhšiu dobu, aby ušetrili energiu, odpojte napájací systém.

Aplikácia

Dotykový spínač je určený na spínanie a vypínanie LED osvetlenie slúži na osvetlenie dreva. Spínač by mal byť použitý v mieste dreva, ktorá je zbarvená reflexného materiálu.

Specifikácie

Napájecie napätie	: 12 VDC
Výstupné napätie	: 12 VDC
Trieda ochrany	: III
Stupeň ochrany	: IP 20
Výkon	: 50 W
Maximálny prúd	: 4,16 A
Rozsah	: max 30 mm

Montáž

- Na mieste spínača montážny povrch dosky musí byť čistý a suchý
- Odlepte ochrannú papierovú pásku.
- Pripojte prepínač do požadovanej polohy.
- Konektor označený "OUTPUT" pripojí LED osvetlenie.
- Konektor označený "INPUT" Pripojenie 12VDC napájania.
- Skontrolujte montáž a pripojenie.

RU - Инструкция по установке

Общее описание

Производитель не несет никакой ответственности за любые повреждения, вызванные неправильным использованием продукта, изменении в конструкции, использование неподходящих предметов, и неудачи данного руководства.

Безопасность

- Коммутатор предназначен для использования в помещении и сделать безопасным напряжением 12 В постоянного тока.
- Общая потребляемая мощность освещения светодиодные не превышает номинальную мощность переключателя. Характеристики указаны на этикетке продукта
- Варианты монтажа рекомендуется инструкцией по установке.
- При установке переключателя не может быть подключен к источнику питания.
- Для чистки используйте только мягкой сухой тканью не используйте моющие средства.
- В случае возникновения каких либо сомнений, обратиться к специалисту. Когда он не используется в течение длительного периода времени в целях экономии электроэнергии отключайте систему питания.

Приложение

Сенсорный выключатель предназначен для включения и выключения светодиодного освещения используется для подсветки деревянной тарелке. Выключатель должен быть использован вместо деревянной тарелке, которое лишено из светоотражающего материала.

Технические условия

Напряжение питания	: 12 В постоянного тока
Выходное напряжение	: 12 В постоянного тока
Класс защиты	: III
Степень защиты	: IP 20
Мощность	: 50 W
Максимальный ток	: 4,16 A
Диапазон	: max 30 mm

Сборка

- На место переключателя монтажной пластины поверхность должна быть чистой и сухой
- Снимите защитную бумажную ленту.
- Подключите переключатель в нужное место.
- Разъем с маркировкой "OUTPUT" подключить источнику питания 12 В постоянного тока.
- Проверьте, монтажа и подключения.

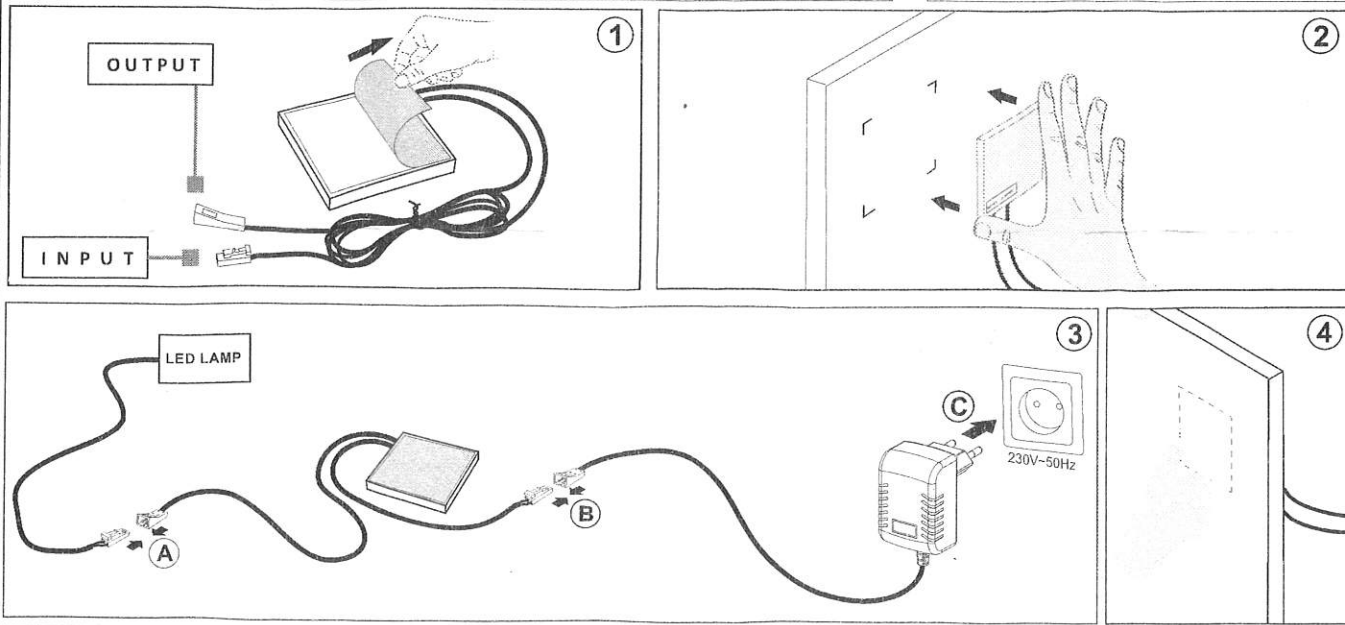

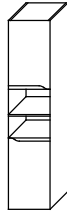

T1 Bitte unbedingt ausfüllen!

Name	
Strasse	
Plz	Ort
Tel.	

T2 Sehr geehrte Kunden,
 wir freuen uns, dass Sie sich für ein Produkt aus dem Hause Pelipal entschieden haben. Sollte es trotz aller Bemühungen unsererseits, Ihnen ein qualitativ hochwertiges Möbelstück zu liefern, zu Fehlteilen kommen, schicken Sie bitte dieses ausgefüllte Blatt an
 Fax.: **+49 3443/434350**
 E-Mail: **ersatzteile@pelipal.de**
 Bitte beachten Sie, dass Bauteile über 800mm Länge und 350mm Breite direkt bei Ihrem Möbelhändler zu beanstanden sind. Zur Reklamationsbearbeitung ist es unbedingt erforderlich **die Artikelnummer des Schrankes**, welche auf dem Etikett ersichtlich ist und den Markt, wo das Möbel erworben wurde anzugeben. Außerdem tragen Sie unten bitte die benötigte Stückzahl ein. Viel Spaß mit Ihrem neuen Badmöbel! Ihr Pelipal Team

-







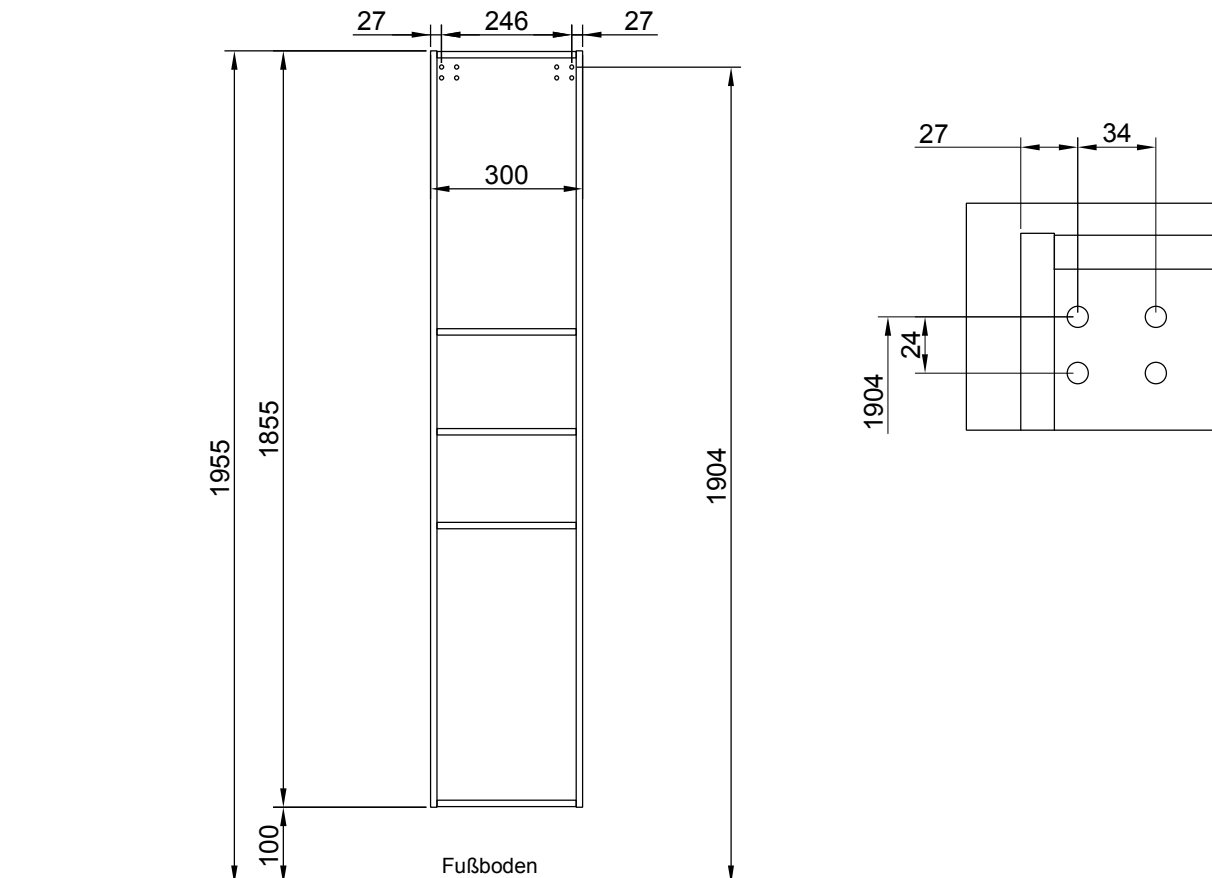



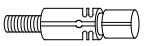

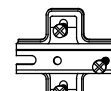
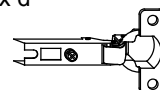
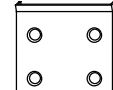
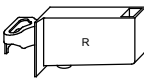
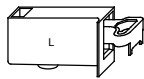
T3 Für den Zusammenbau sind 2 Personen erforderlich.

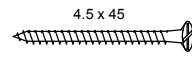
T4 Montage-Richtzeit 3 Stunden

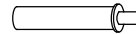
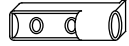
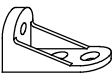
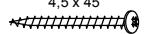

Die Maßangabe der Höhe ist nicht bindend!

20 x a  DUEB-SMD-000005	Stück	20 x b  EXZENTER-000015	Stück	4 x c  ZPL-003X004	Stück	4 x d  TBD-35-115X00	Stück	2 x e  AUF-001-000030	Stück
1 x f  AUF-001-000080	Stück	1 x g  AUF-001-000090	Stück	4 x h 35 x 38  ADKWE1-035X038	Stück	8 x h 4.5 x 45  SCH-SPA-045X045	Stück	12 x k 3.5 x 15  SCH-SPA-035X015	Stück
20 x l  NAGEL-025X001	Stück	8 x m  VBD-000120	Stück	8 x n  TRAE-001-000020	Stück	2 x o  TUER-DAEM-000010	Stück	2 x p  TUER-ADA-000010	Stück
1 x r  VBD-000020	Stück	1 x s 4,5 x 45  SCH-RDK-045X045	Stück	1 x t 4,0 x 15  SCH-RDK-040X015	Stück		Stück		Stück

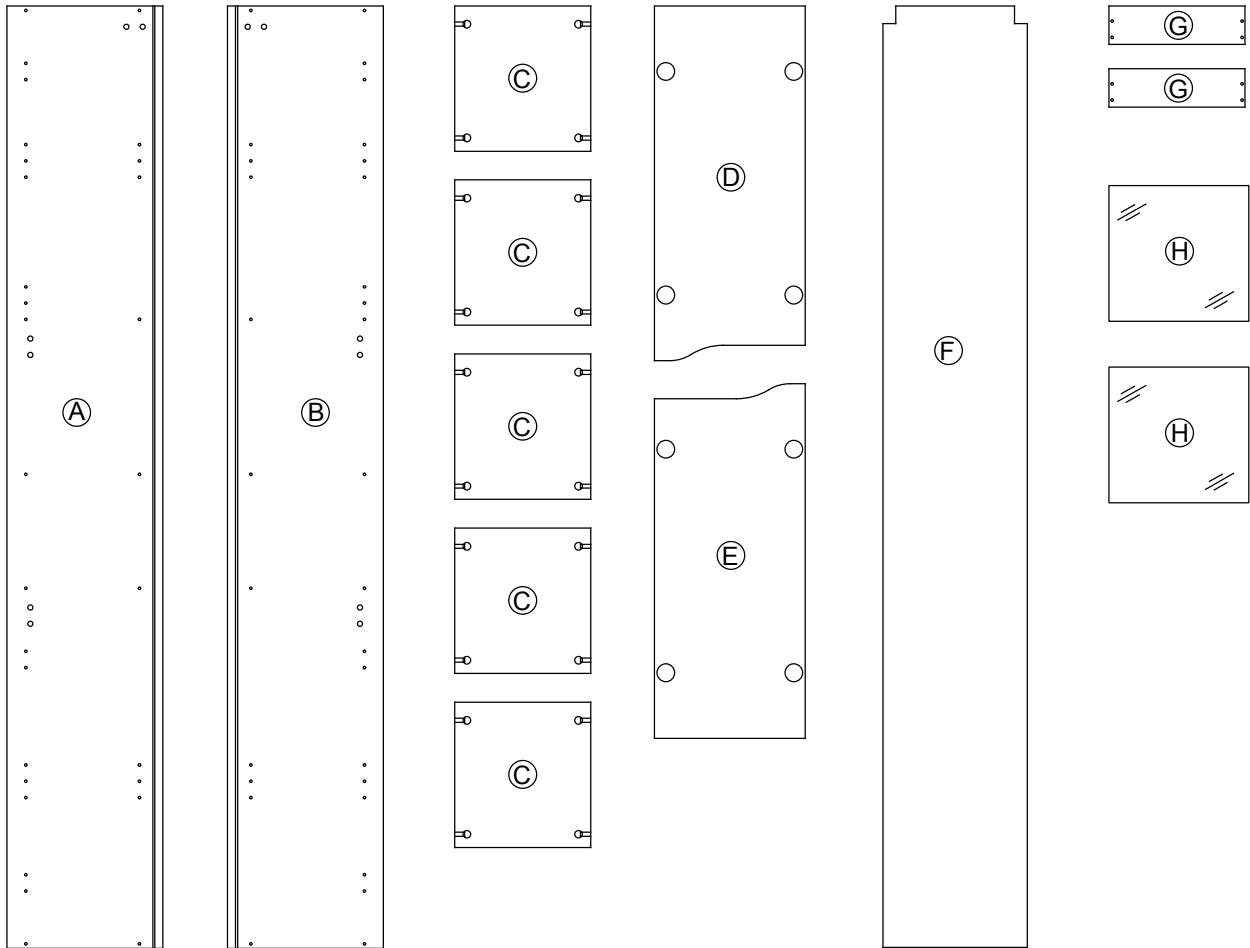

1.

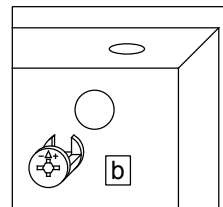
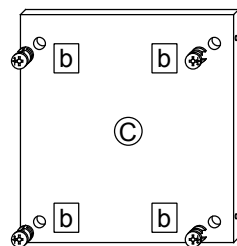
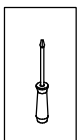

2.

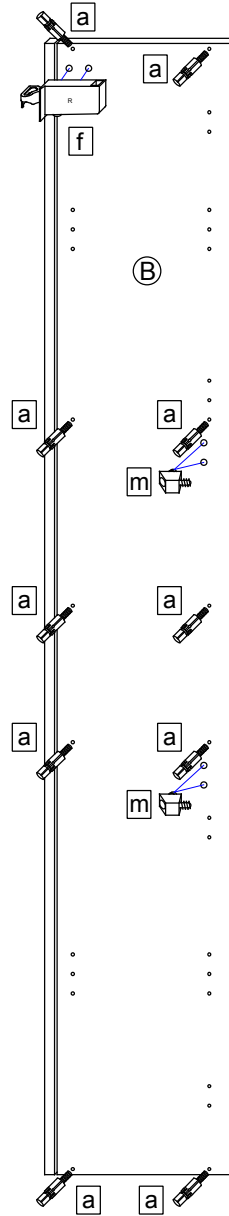
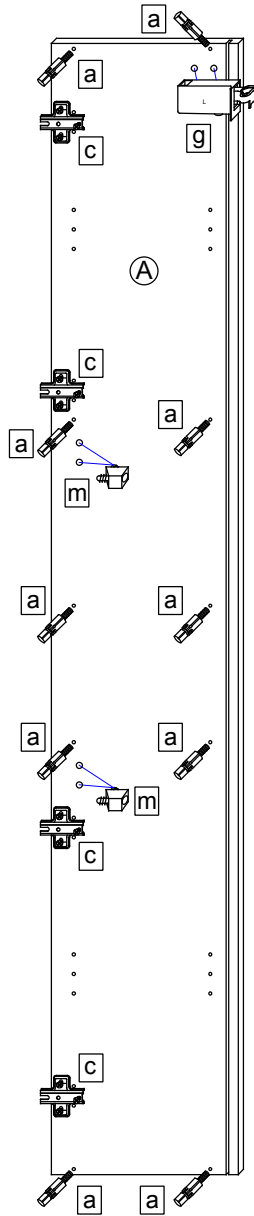
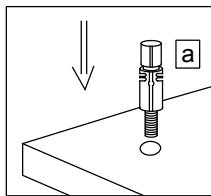
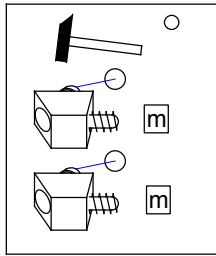
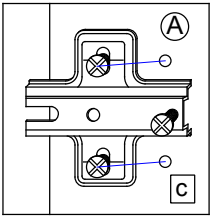
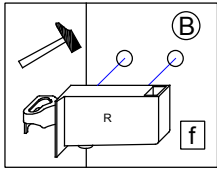
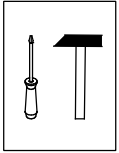

3.

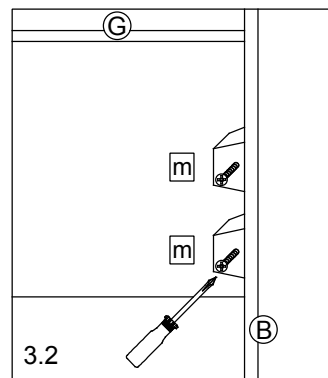
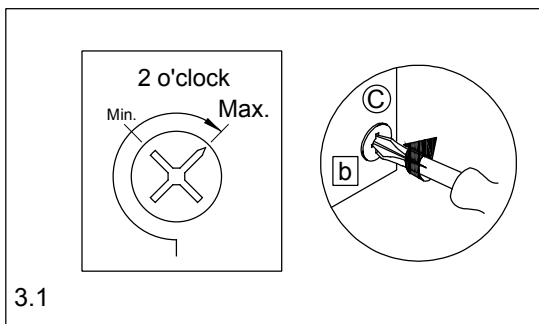
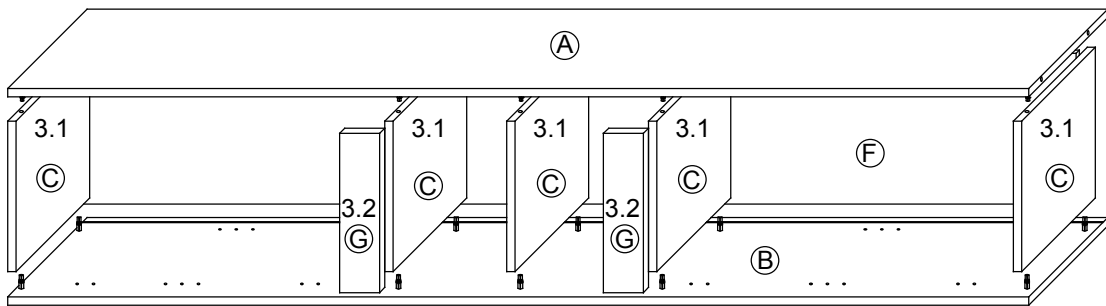
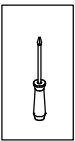

4.

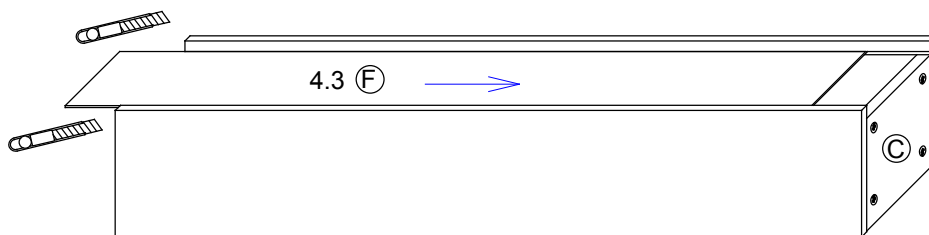
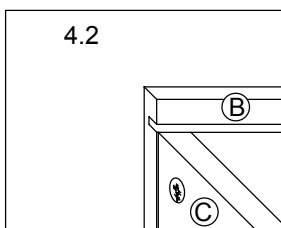
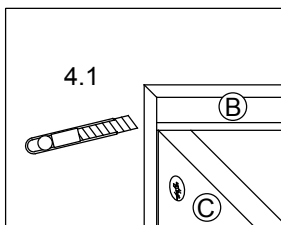
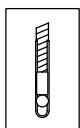

5.

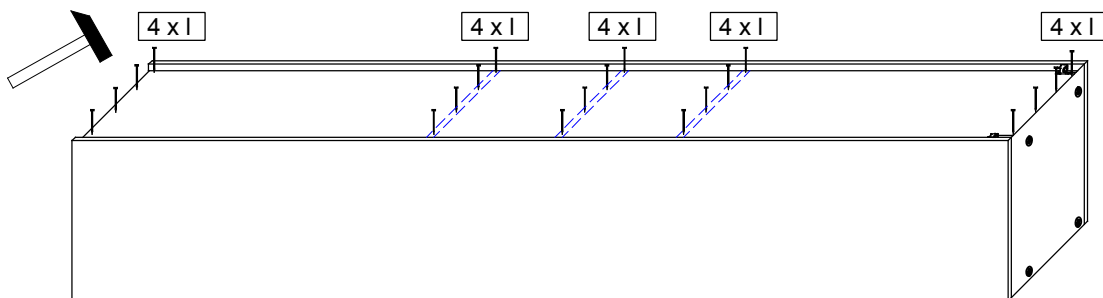
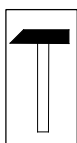

6.

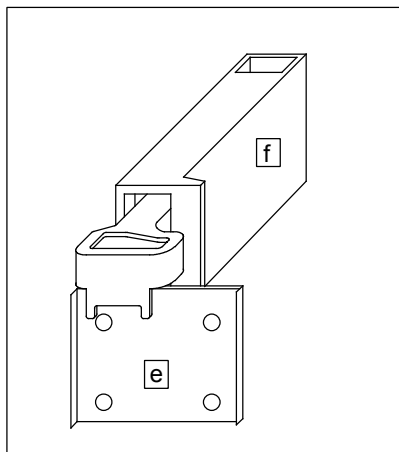
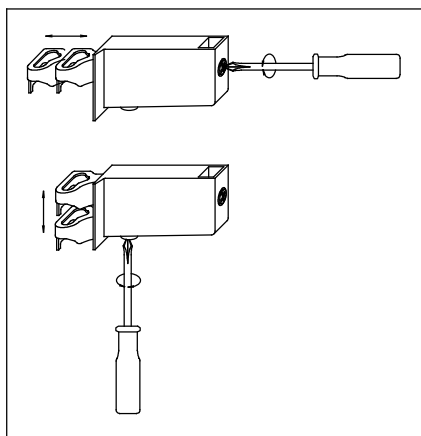
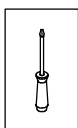

T9

Lassen Sie den Schrank nur durch fachkundige Personen mit für die Wand geeignetem Montagematerialien montieren.

T6

Die Schrankaufhänger dienen zur Kippsicherung des Schrankes und müssen grundsätzlich montiert werden.

T8 Wand

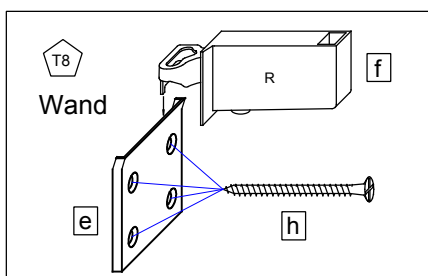
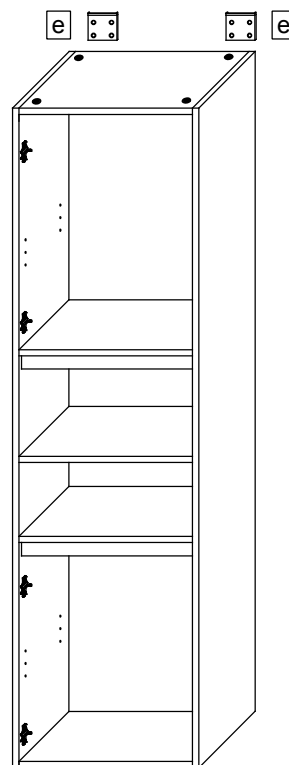

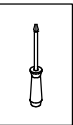
7. 

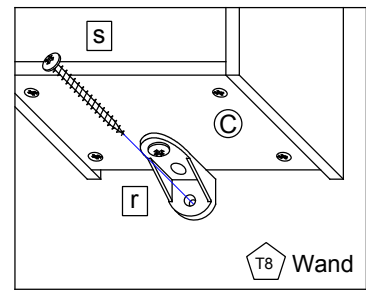
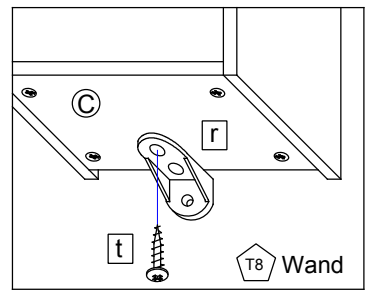

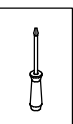
8. 

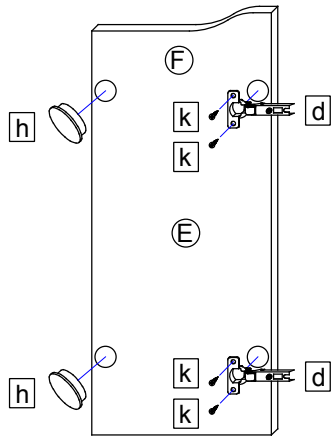
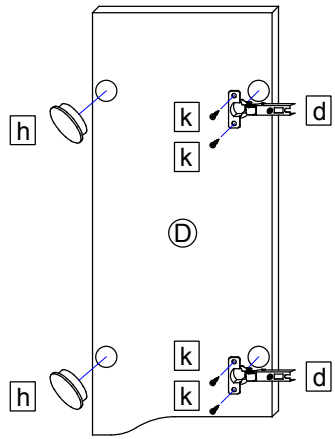
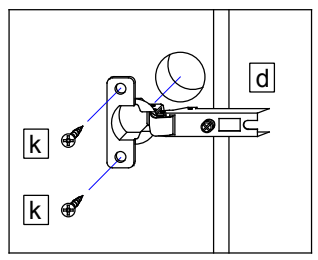

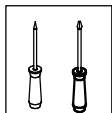
9. 

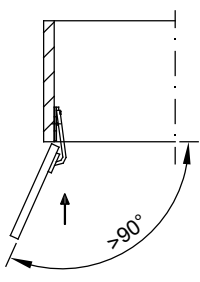
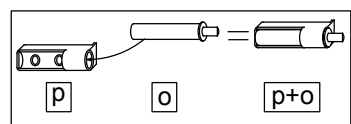
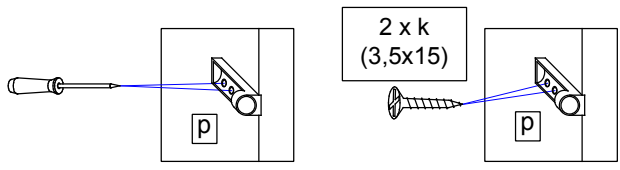

Bei Türmontage das Scharnier einhängen, bis Anschlag öffnen und anschließend festschrauben.

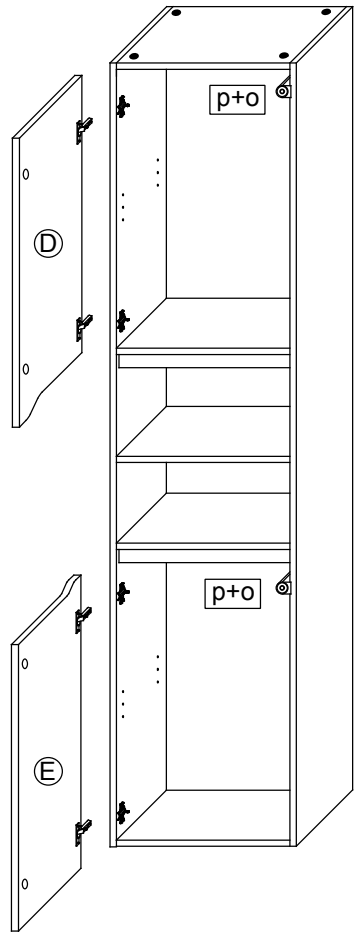
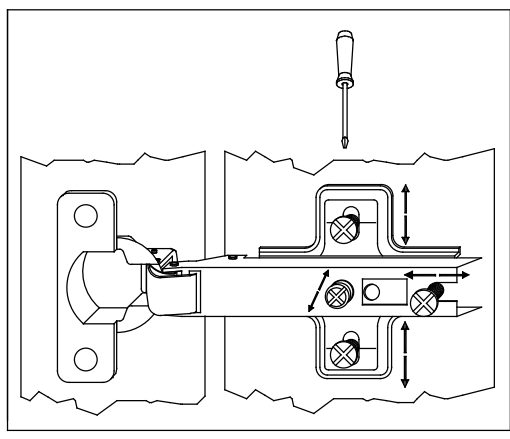

10.

MOT-NZ0954S6 A4

Datum 04/06/19

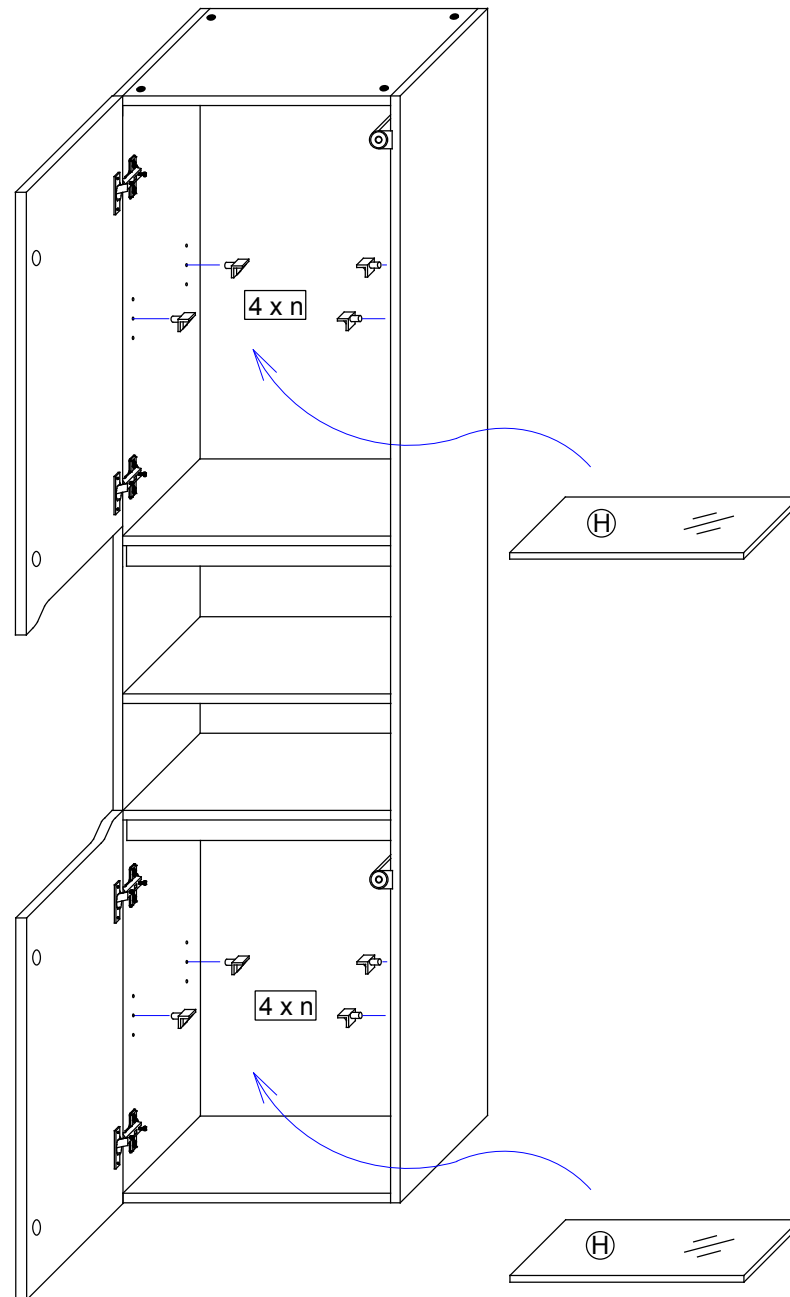

 Das Möbel bitte nur mit einem feuchten Tuch reinigen.

pelipal

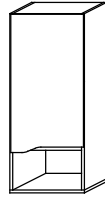

3__-013030

MOT-NZ0951S1 A4

Datum 27/05/19



Bitte unbedingt ausfüllen!

Name	
Strasse	
Plz	Ort
Tel.	



Sehr geehrte Kunden,

wir freuen uns, dass Sie sich für ein Produkt aus dem Hause Pelipal entschieden haben. Sollte es trotz aller Bemühungen unsererseits, Ihnen ein qualitativ hochwertiges Möbelstück zu liefern, zu Fehlteilen kommen, schicken Sie bitte dieses ausgefüllte Blatt an

Fax.: **+49 3443/434350**E-Mail: **ersatzteile@pelipal.de**

Bitte beachten Sie, dass Bauteile über 800mm Länge und 350mm Breite direkt bei Ihrem Möbelhändler zu beanstanden sind. Zur Reklamationsbearbeitung ist es unbedingt erforderlich **die Artikelnummer des Schrankes**, welche auf dem Etikett ersichtlich ist und den Markt, wo das Möbel erworben wurde anzugeben. Außerdem tragen Sie unten bitte die benötigte Stückzahl ein. Viel Spaß mit Ihrem neuen Badmöbel! Ihr Pelipal Team

--









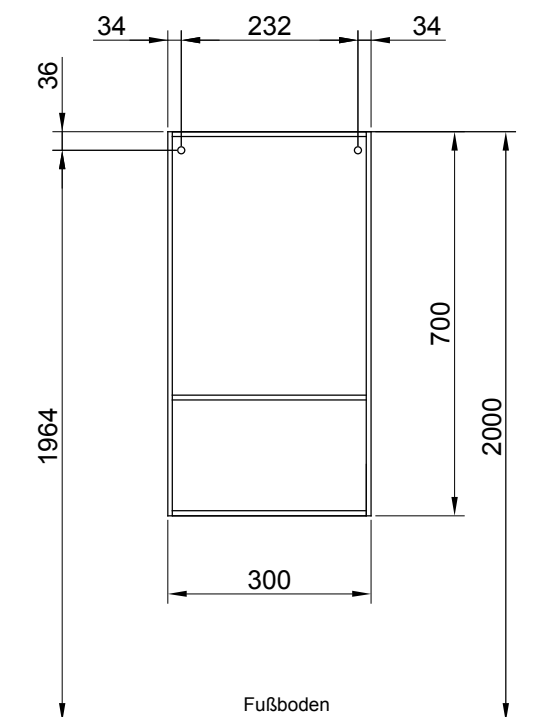

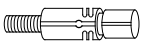

Für den Zusammenbau sind 2 Personen erforderlich.

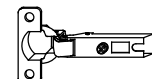
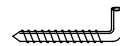

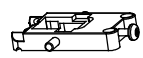
Montage-Richtzeit 3 Stunden

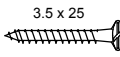
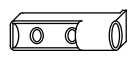
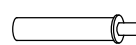
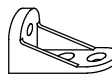
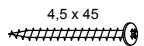

Die Maßangabe der Höhe ist nicht bindend!

12 x a  DUEB-SMD-000005	Stück	12 x b  EXZENTER-000015	Stück	2 x c  ZPL-003X004	Stück	2 x d  TBD-35-115X00	Stück	2 x e  AUF-001-000020	Stück
4 x f  TRAE-001-000020	Stück	2 x g  AUF-001-000060	Stück	4 x h  VBD-000120	Stück	2 x j 35 x 38  ADK-WE1-035X038	Stück	6 x k 3.5 x 15  SCH-SPA-035X015	Stück
12 x l  NAGEL-025X001	Stück	4 x m 3.5 x 25  SCH-SPA-035X025	Stück	1 x n  TUER-ADA-000010	Stück	1 x o  TUER-DAEM-000010	Stück	1 x p  VBD-000020	Stück
1 x r 4,5 x 45  SCH-RDK-045X045	Stück	1 x s 4,0 x 15  SCH-RDK-040X015	Stück		Stück		Stück		Stück

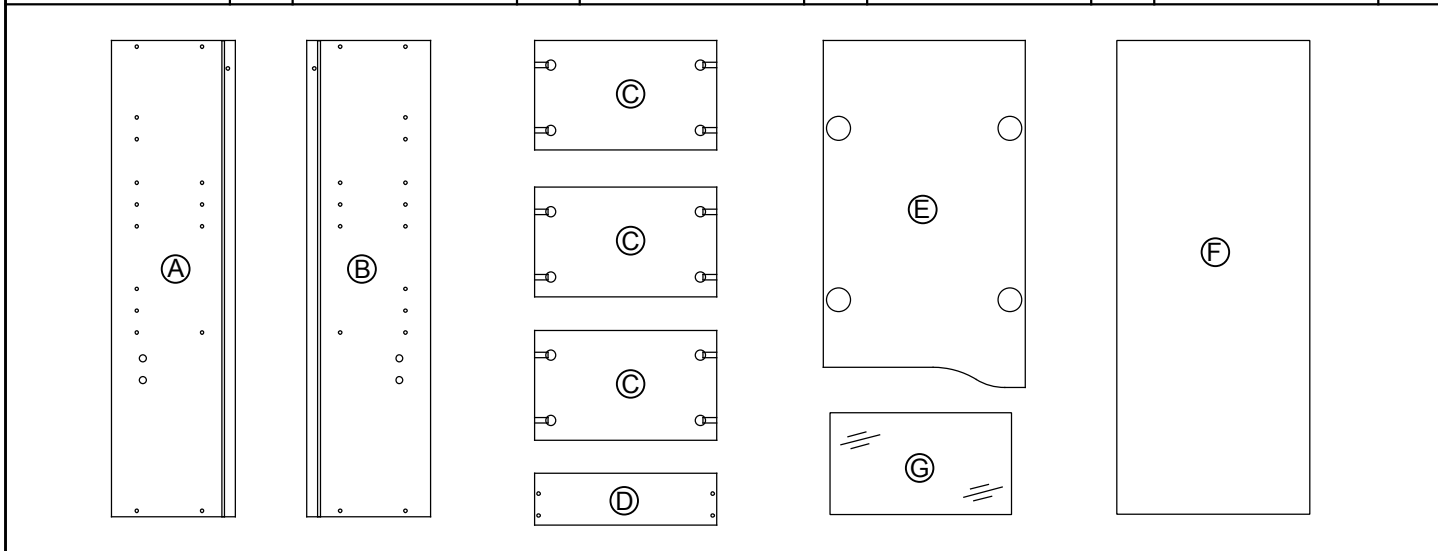

1.

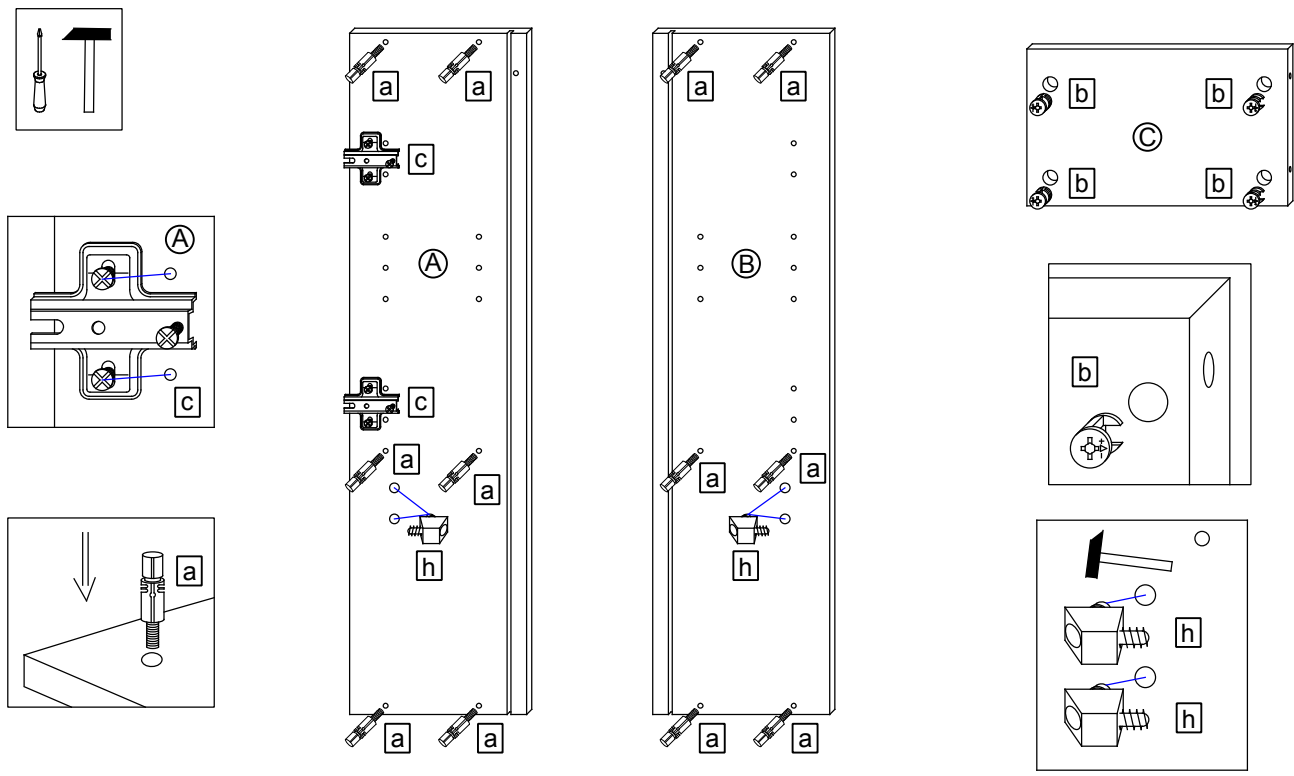

2.

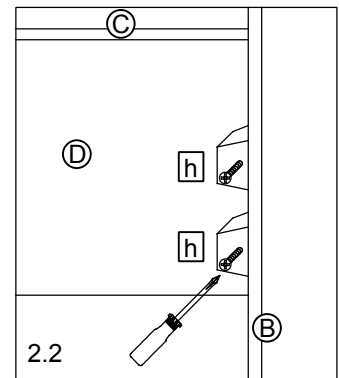
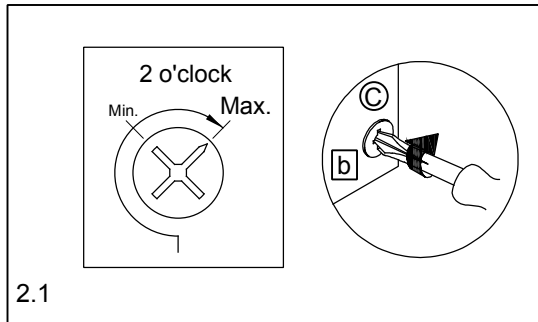
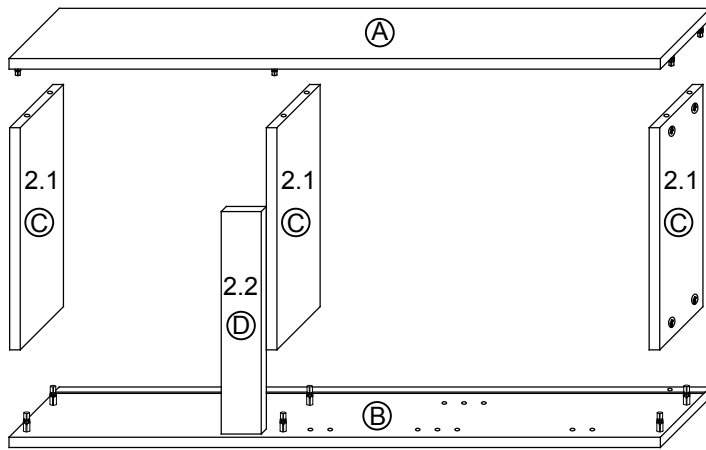
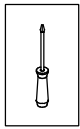

3.

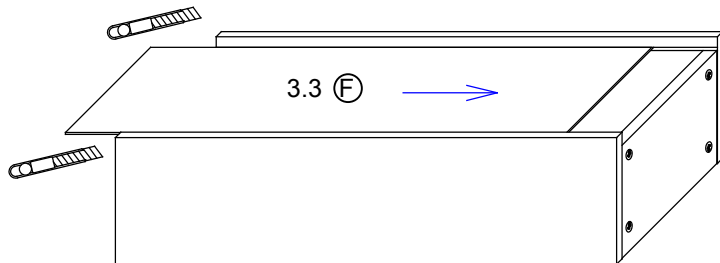
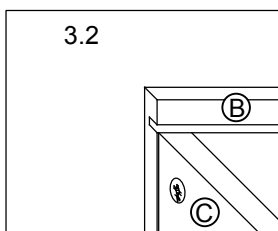
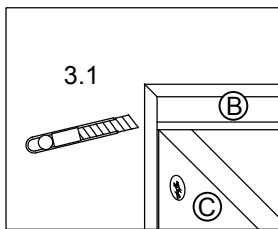
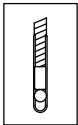

4.

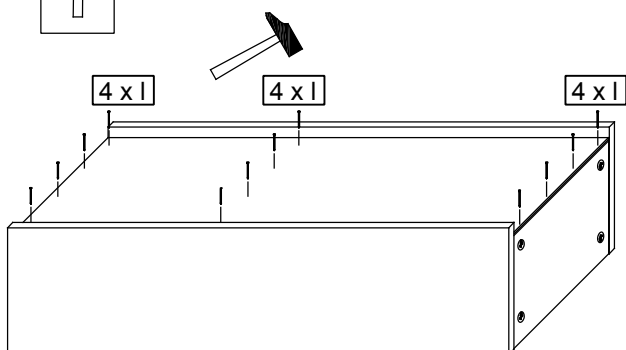
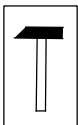

5.

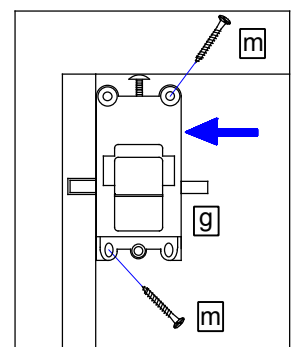
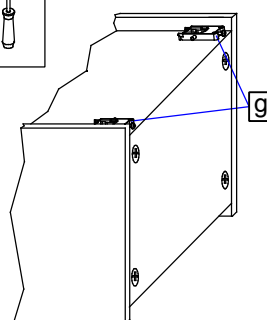
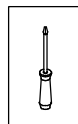

6.

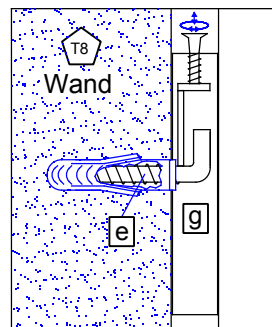
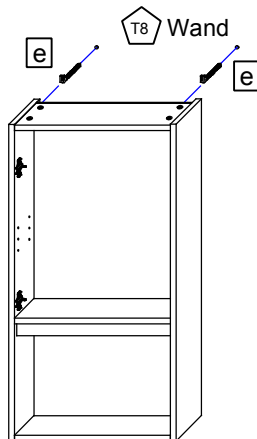
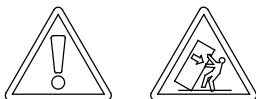
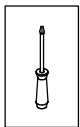

T9 Lassen Sie den Schrank nur durch fachkundige Personen mit für die Wand geeignetem Montagematerialien montieren.

7.

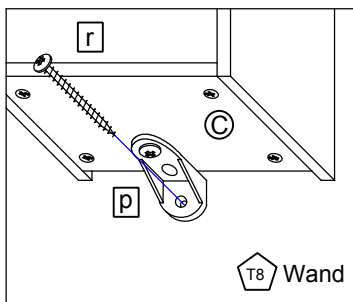
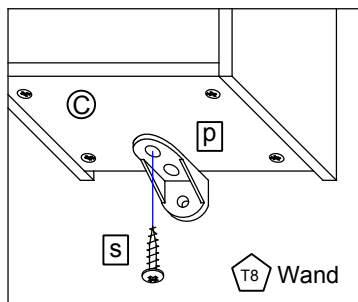
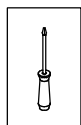

8.

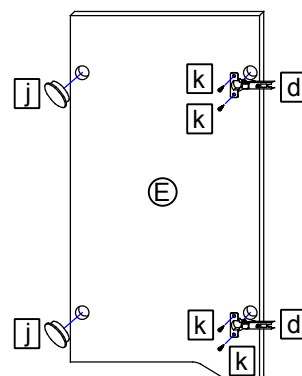
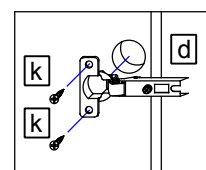
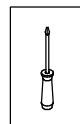

9.

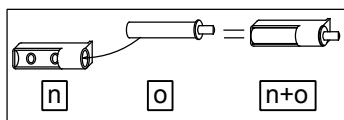
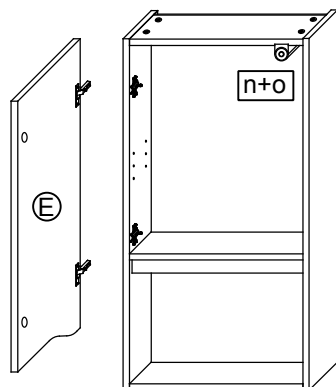
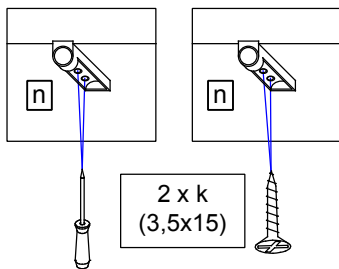
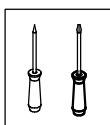

T11 Bei Türmontage das Scharnier einhängen, bis Anschlag öffnen und anschließend festschrauben.

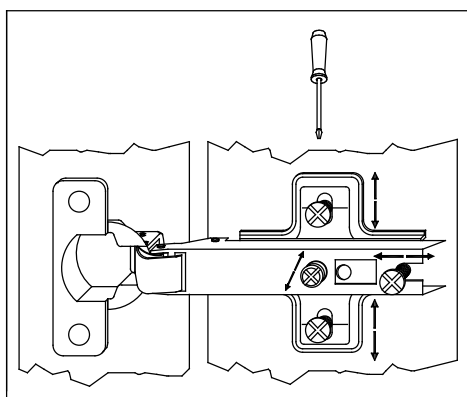
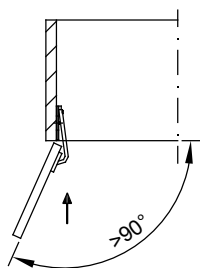

10.

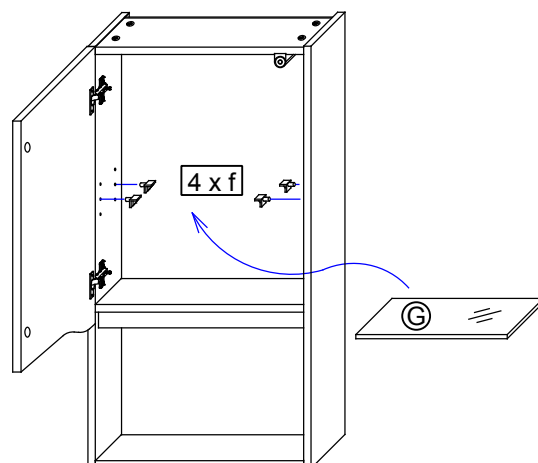

T12 Das Möbel bitte nur mit einem feuchten Tuch reinigen.

pelipal

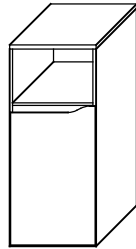

MOT-NZ0952S1 A4
Datum 28/05/19

3 _ _ -013040

T1

Bitte unbedingt ausfüllen!

Name	
Strasse	
Plz	Ort
Tel.	

T2

Sehr geehrte Kunden,
wir freuen uns, dass Sie sich für ein Produkt aus dem Hause Pelipal entschieden haben. Sollte es trotz aller Bemühungen unsererseits, Ihnen ein qualitativ hochwertiges Möbelstück zu liefern, zu Fehlteilen kommen, schicken Sie bitte dieses ausgefüllte Blatt an

Fax.: **+49 3443/434350**

E-Mail: **ersatzteile@pelipal.de**

Bitte beachten Sie, dass Bauteile über 800mm Länge und 350mm Breite direkt bei Ihrem Möbelhändler zu beanstanden sind. Zur Reklamationsbearbeitung ist es unbedingt erforderlich **die Artikelnummer des Schrankes**, welche auf dem Etikett ersichtlich ist und den Markt, wo das Möbel erworben wurde anzugeben. Außerdem tragen Sie unten bitte die benötigte Stückzahl ein. Viel Spaß mit Ihrem neuen Badmöbel! Ihr Pelipal Team

--



T3







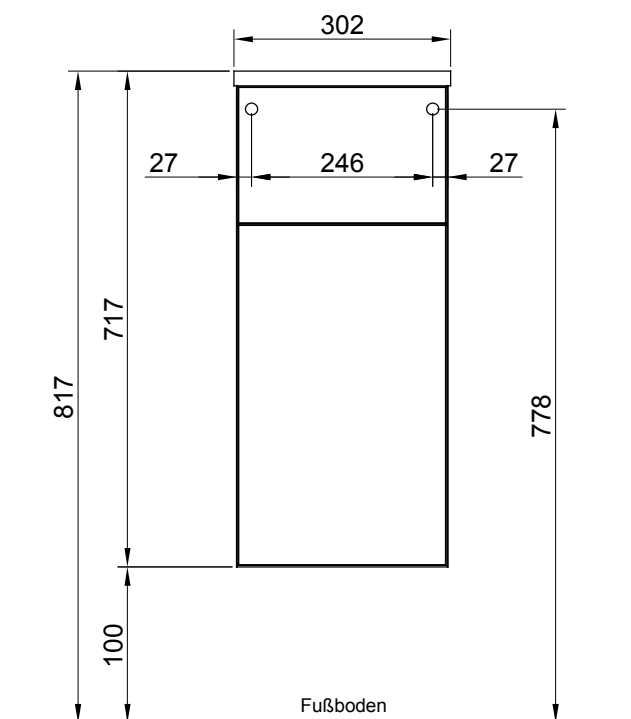



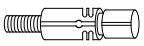

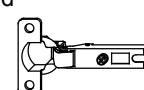
Für den Zusammenbau sind 2 Personen erforderlich.

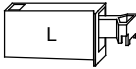
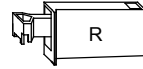
T4

Montage-Richtzeit 3 Stunden

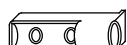
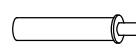
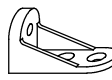
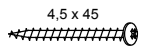

Die Maßangabe der Höhe ist nicht bindend!

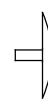
12 x a  DUEB-SMD-000005	Stück	12 x b  EXZENTER-000015	Stück	2 x c  ZPL-003X004	Stück	2 x d  TBD-35-115X00	Stück	2 x e  AUF-001-000020	Stück
1 x f  AUF-001-000090	Stück	1 x g  AUF-001-000080	Stück	4 x h  VBD-000120	Stück	2 x j  ADK-WE1-035X038	Stück	8 x k  SCH-SPA-035X015	Stück
8 x l  NAGEL-025X001	Stück	2 x m  RWD-KEI-000060	Stück	1 x n  TUER-ADA-000010	Stück	1 x o  TUER-DAEM-000010	Stück	1 x p  VBD-000020	Stück
1 x r  SCH-RDK-045X045	Stück	1 x s  SCH-RDK-040X015	Stück	4 x t  TRAE-001-000020	Stück	4 x u  ADK-BES-AL0010	Stück		Stück

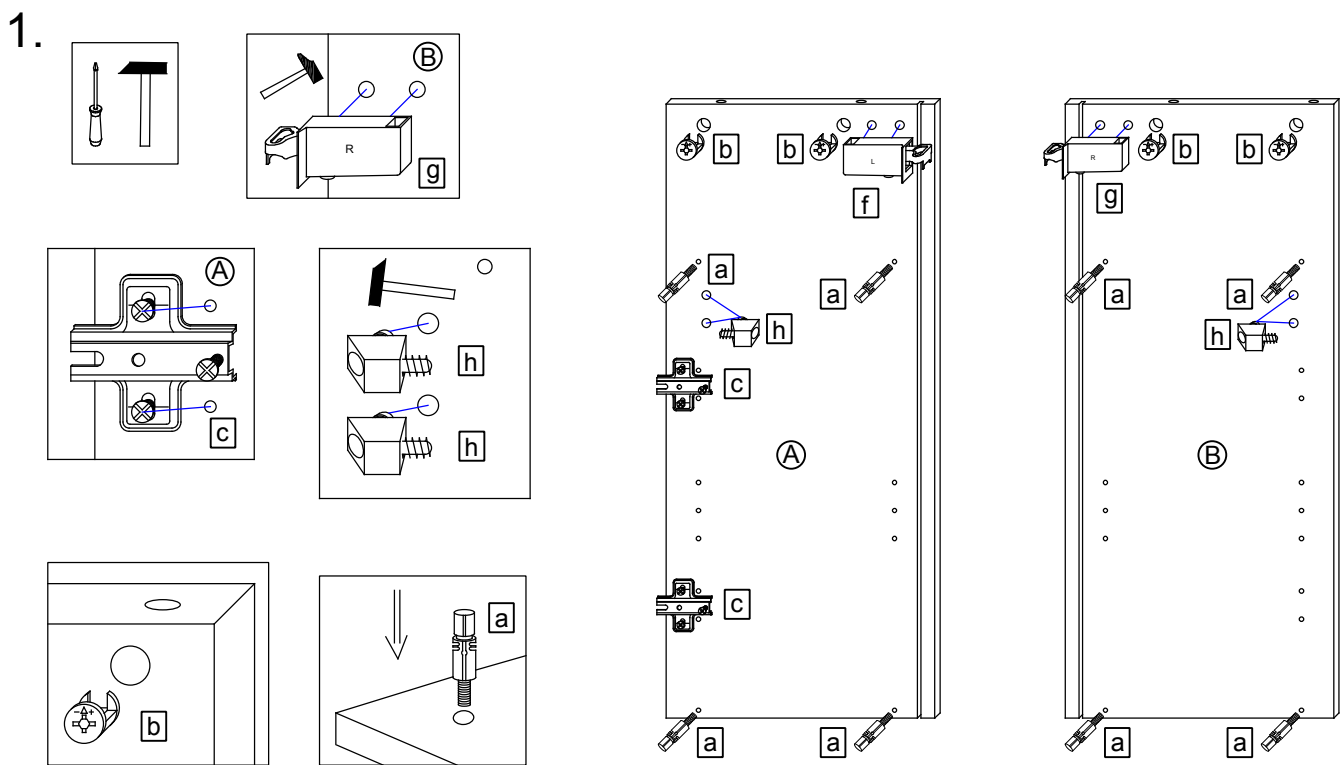
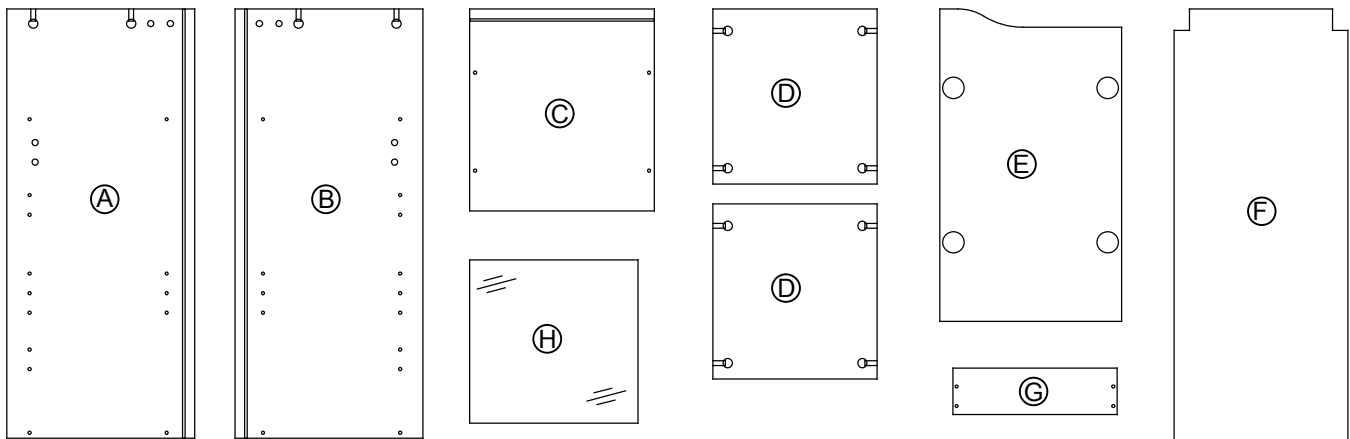

2.

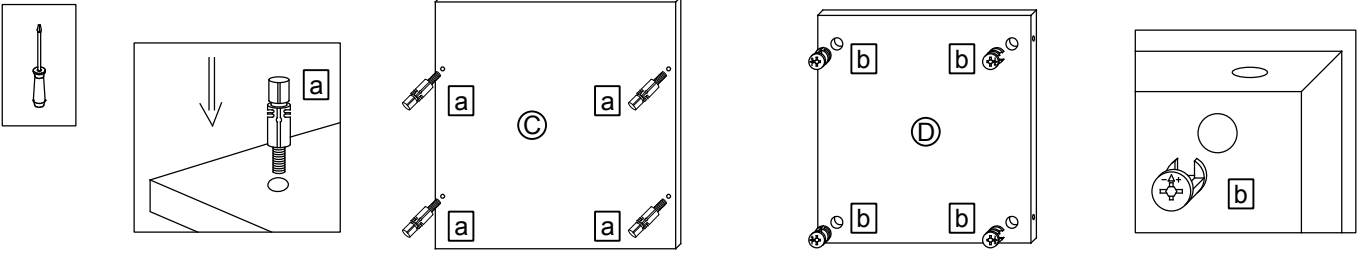

3.

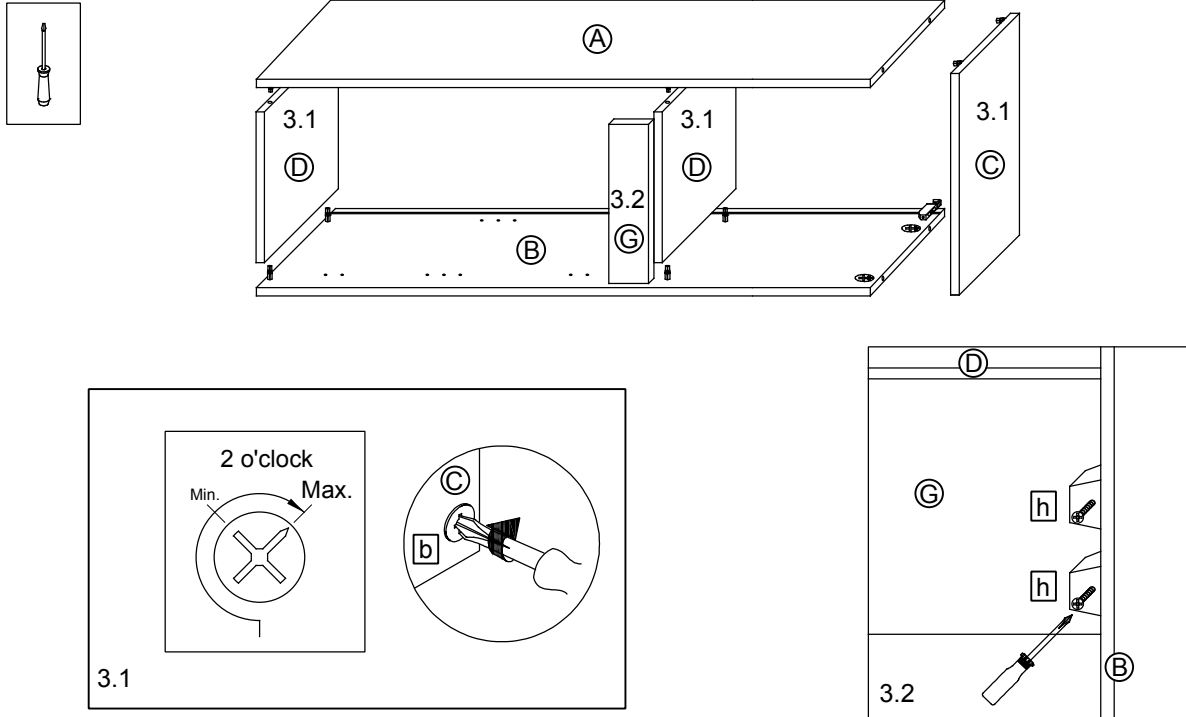

4.

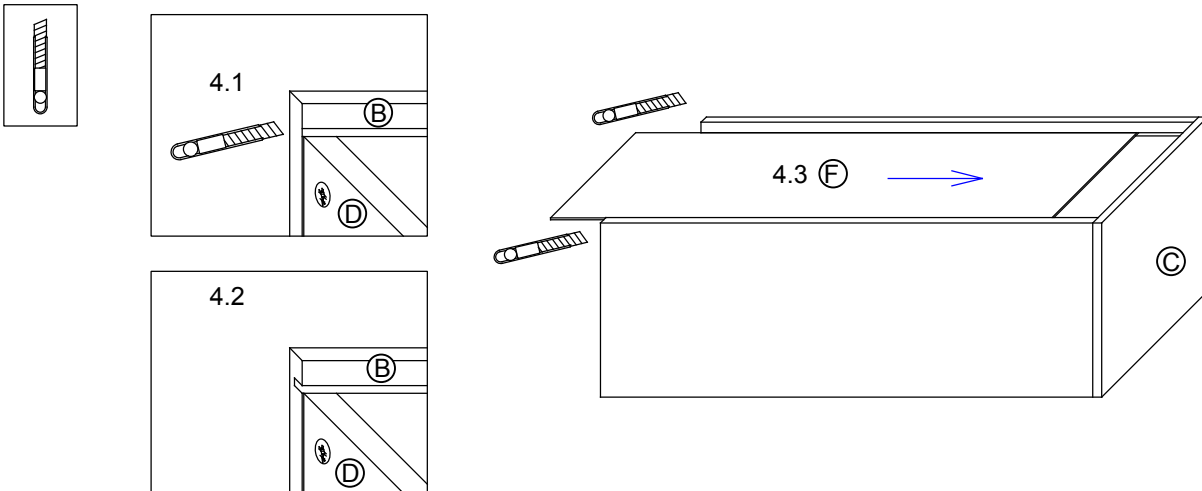

5.

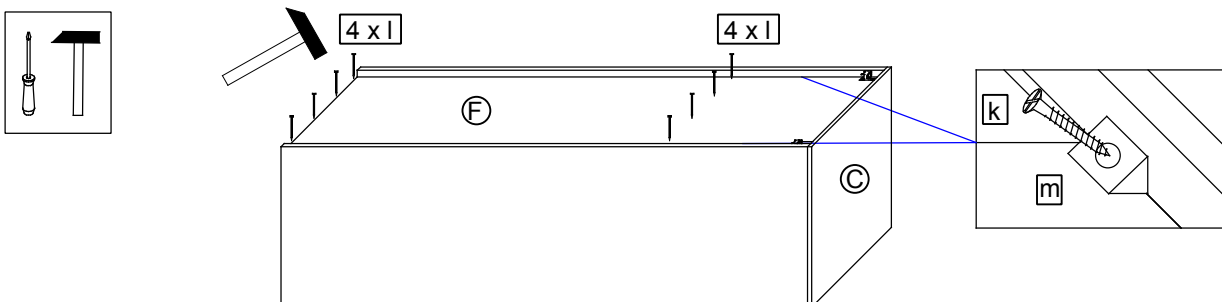

6.

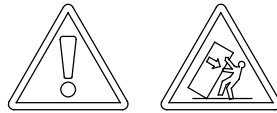
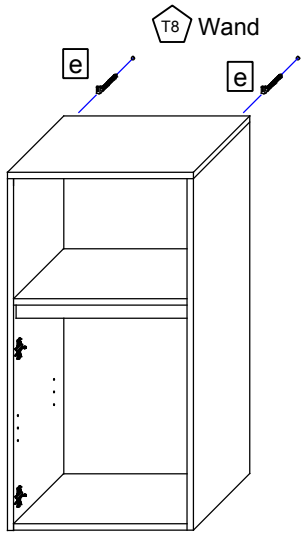
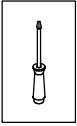

T9

Lassen Sie den Schrank nur durch fachkundige Personen mit für die Wand geeignetem Montagematerialien montieren.

T6

Die Schrankaufhänger dienen zur Kippsicherung des Schrankes und müssen grundsätzlich montiert werden.

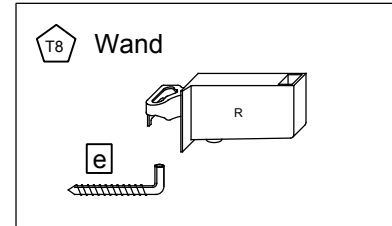
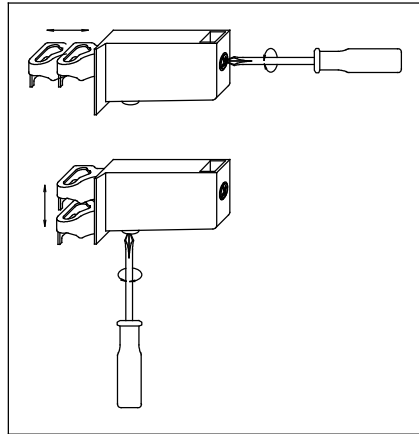

7.

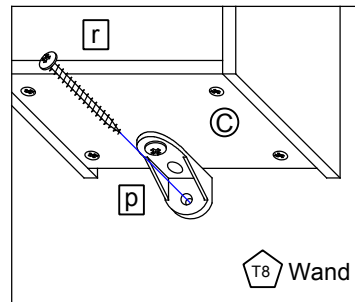
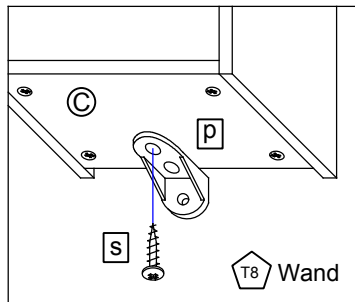
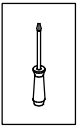

8.

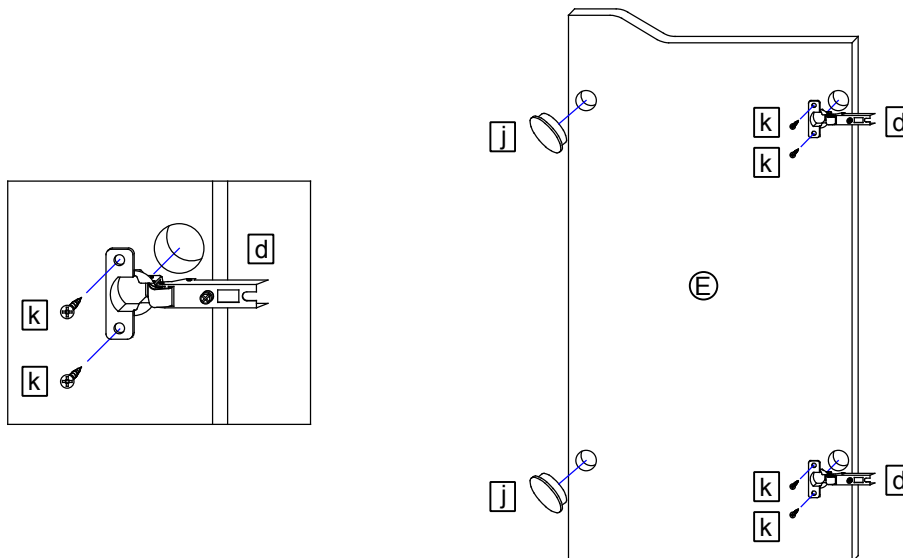
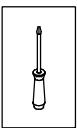

9.

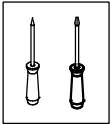

Bei Türmontage das Scharnier einhängen, bis Anschlag öffnen und anschließend festschrauben.

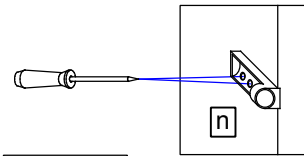
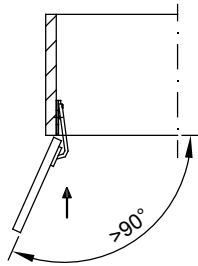
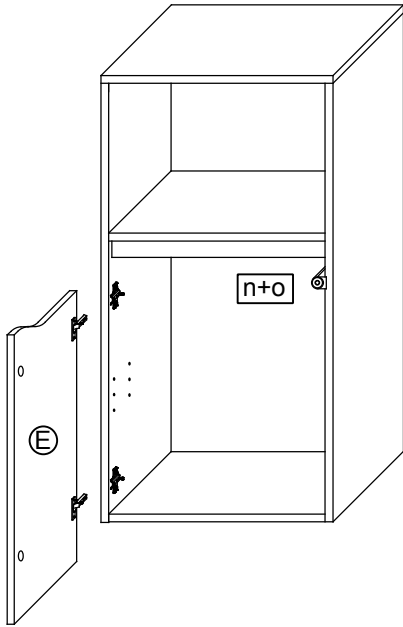

2 x k
(3,5x15)

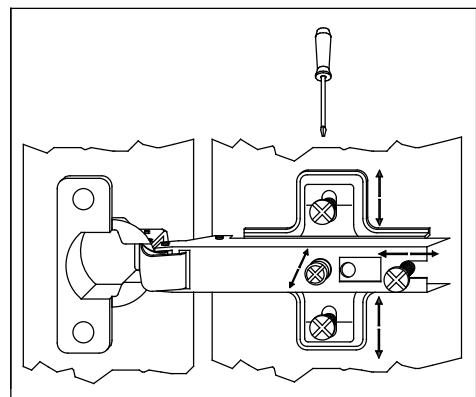
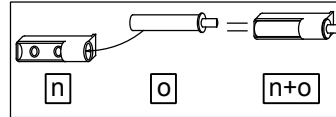
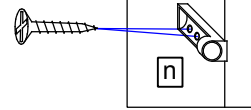

10.

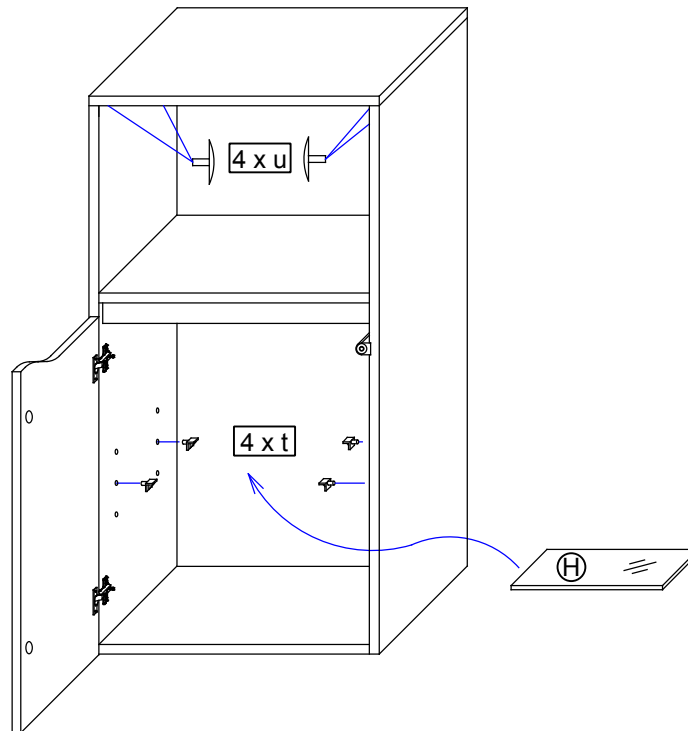

Das Möbel bitte nur mit einem feuchten Tuch reinigen.

pelipal

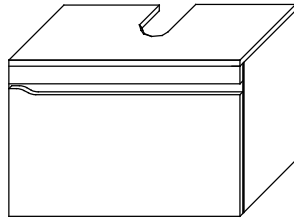

MOT-NZ0955S1 A4

Datum 03/06/19

3__ - 016015

T1

Bitte unbedingt ausfüllen!

Name _____

Strasse _____

Plz _____

Ort _____

Tel. _____

T2

Sehr geehrte Kunden,
wir freuen uns, dass Sie sich für ein Produkt aus dem Hause Pelipal entschieden haben. Sollte es trotz aller Bemühungen unsererseits, Ihnen ein qualitativ hochwertiges Möbelstück zu liefern, zu Fehlteilen kommen, schicken Sie bitte dieses ausgefüllte Blatt an

Fax.: **+49 3443/434350**E-Mail: **ersatzteile@pelipal.de**

Bitte beachten Sie, dass Bauteile über 800mm Länge und 350mm Breite direkt bei Ihrem Möbelhändler zu beanstanden sind. Zur Reklamationsbearbeitung ist es unbedingt erforderlich **die Artikelnummer des Schrankes**, welche auf dem Etikett ersichtlich ist und den Markt, wo das Möbel erworben wurde anzugeben. Außerdem tragen Sie unten bitte die benötigte Stückzahl ein. Viel Spaß mit Ihrem neuen Badmöbel! Ihr Pelipal Team

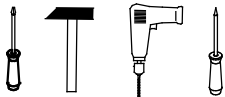

T3







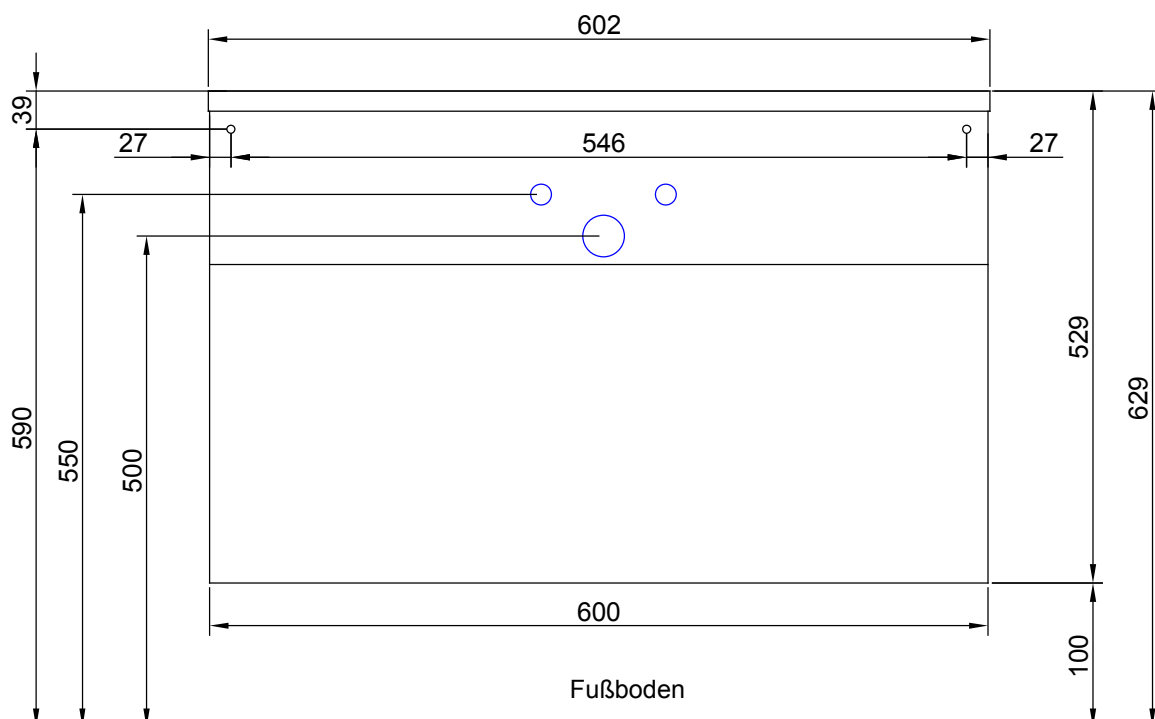



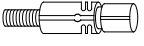

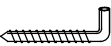

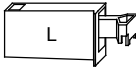
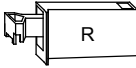

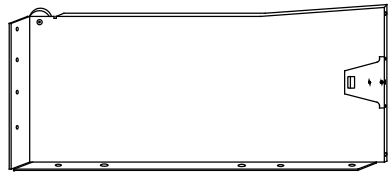
Für den Zusammenbau sind 2 Personen erforderlich.

T4

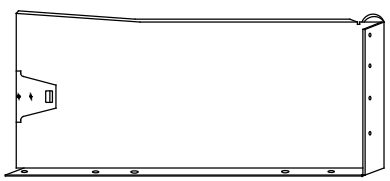
Montage-Richtzeit 3 Stunden

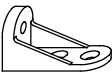
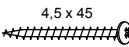

Die Maßangabe der Höhe ist nicht bindend!

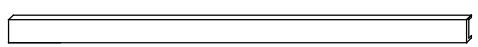
10 x a  DUEB-SMD-000005	Stück	10 x b  EXZENTER-000015	Stück	2 x c  AUF-001-000020	Stück	1 x m  1 x n 
1 x d  AUF-001-000090	Stück	1 x e  AUF-001-000080	Stück	2 x f  DUEB-HLZ-008X030	Stück	1 x o 
6 x g  SCH-SPA-035X015	Stück	10 x h  NAGEL-025X001	Stück	2 x i  RWD-KEI-000060	Stück	1 x p 
4 x j  VBD-000120	Stück	6 x k  SCH-KA-063X011	Stück	10 x l  SCH-RDK-035X015	Stück	Stück KA-SZ-270X150
1 x r  VBD-000020	Stück	1 x s  SCH-RDK-045X045	Stück	1 x t  SCH-RDK-040X015	Stück	1 x u  Kantenprofil

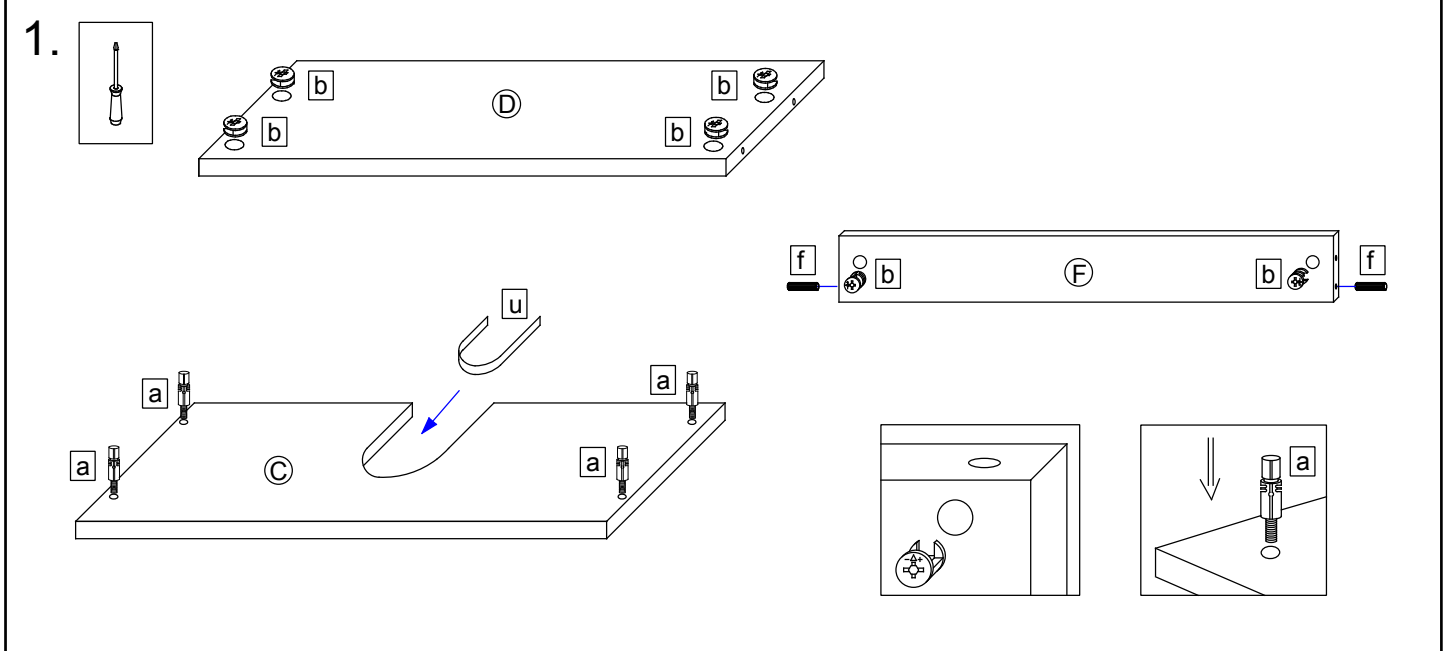
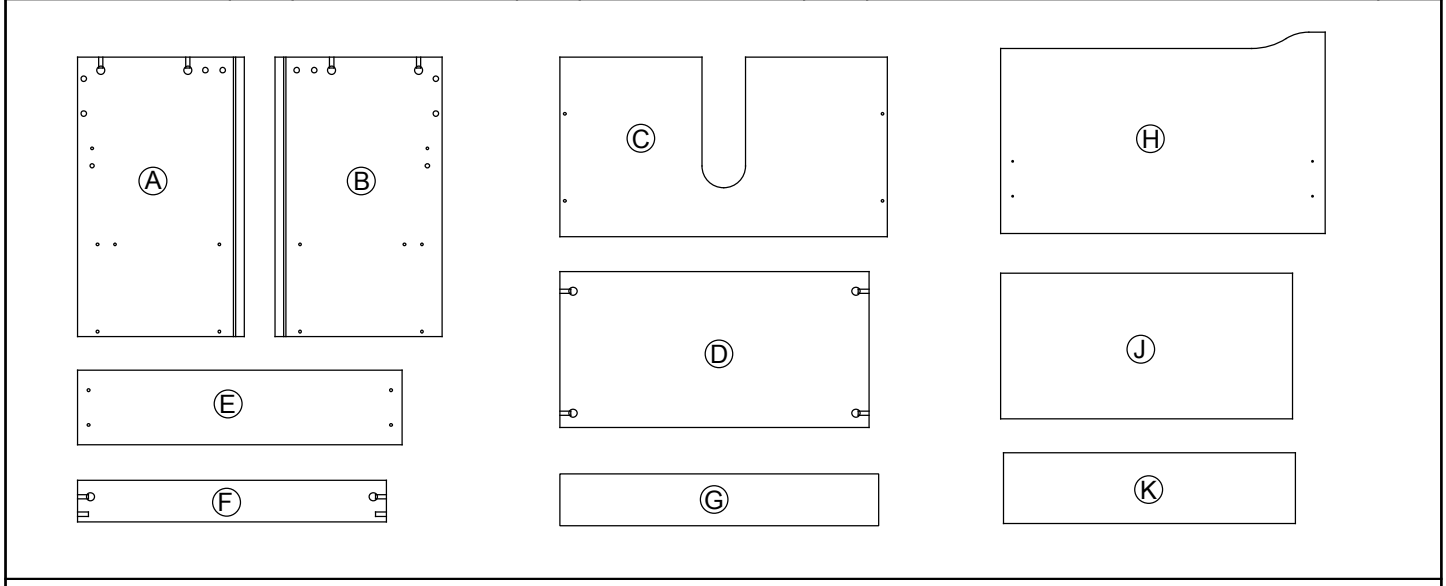

2.

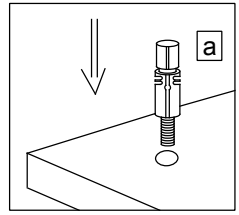
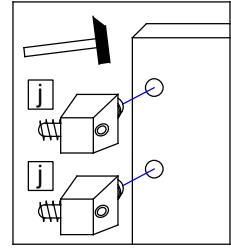
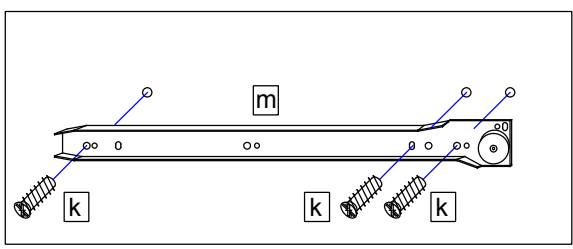
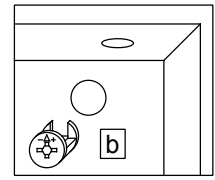
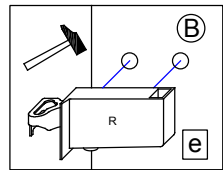
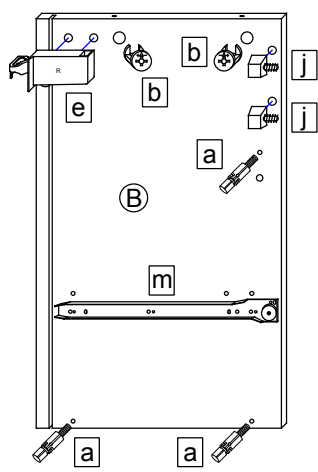
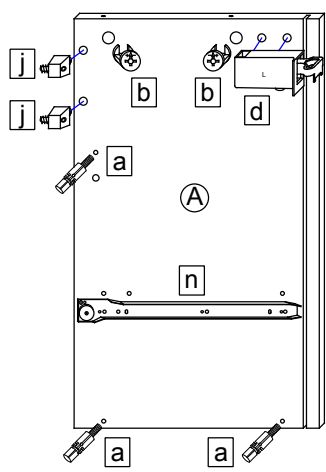
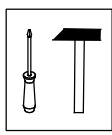

3.

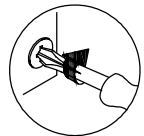
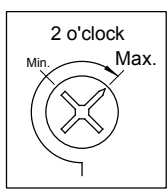
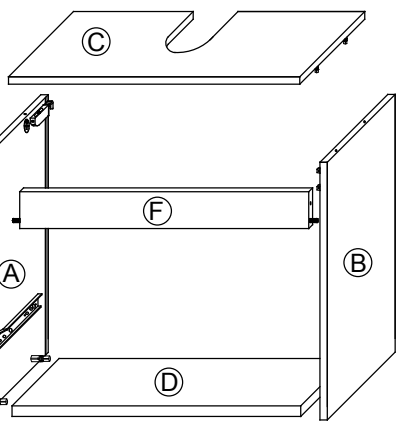
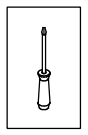

4.

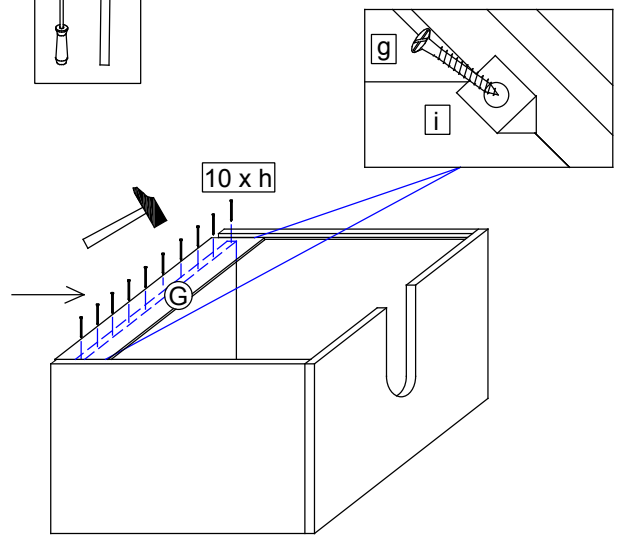
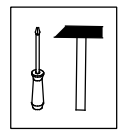

5.

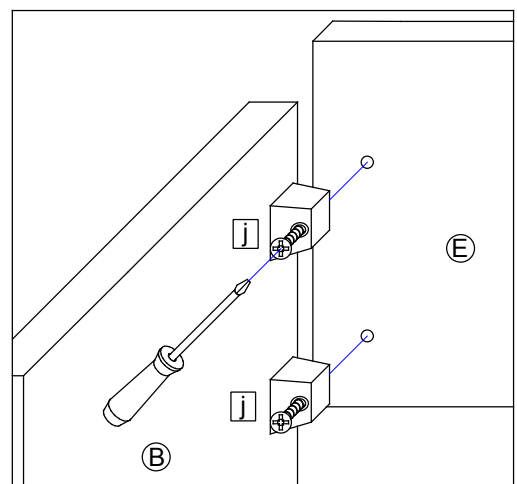
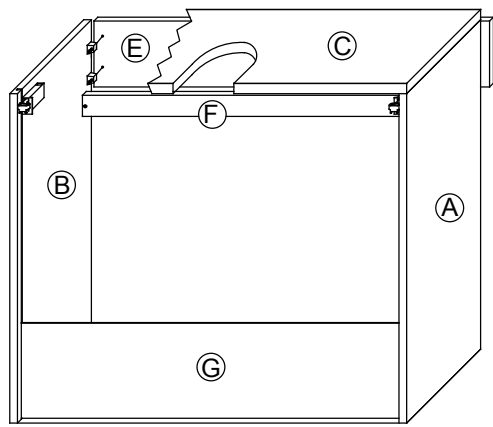
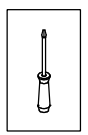

6.

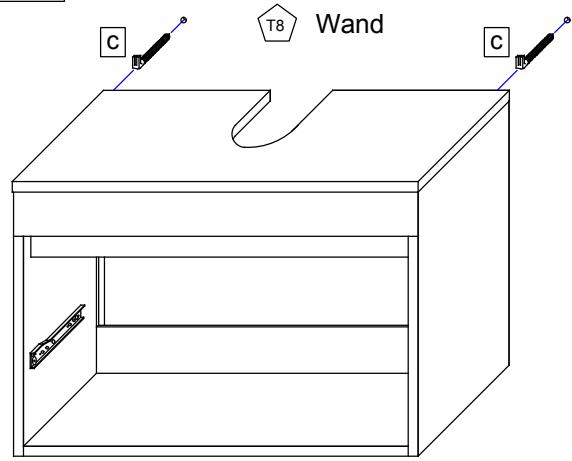
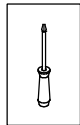

T6 Die Schrankaufhänger dienen zur Kippsicherung des Schrankes und müssen grundsätzlich montiert werden.



T9 Lassen Sie den Schrank nur durch fachkundige Personen mit für die Wand geeigneten Montagematerialien montieren.

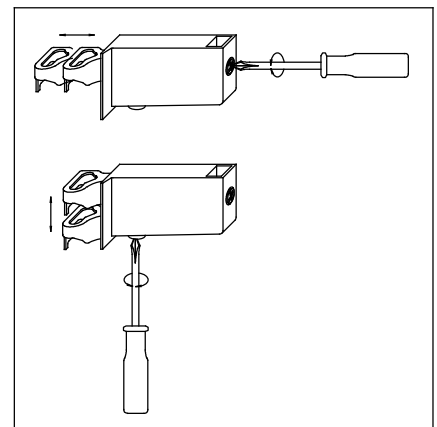
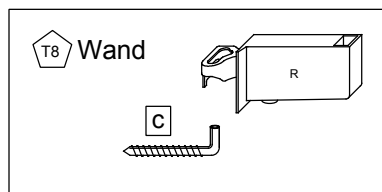

7.

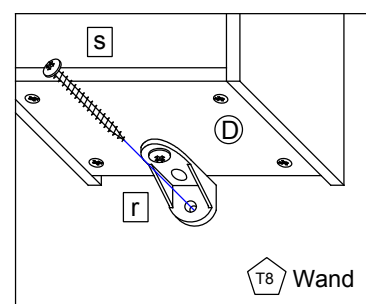
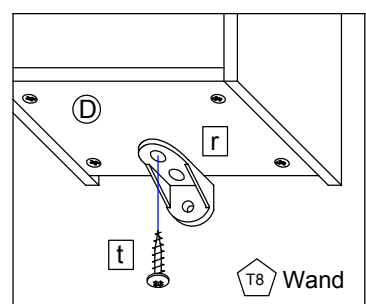
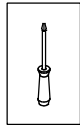

8.

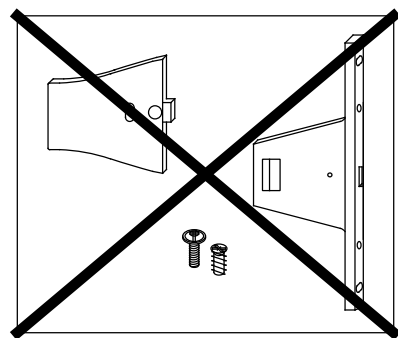
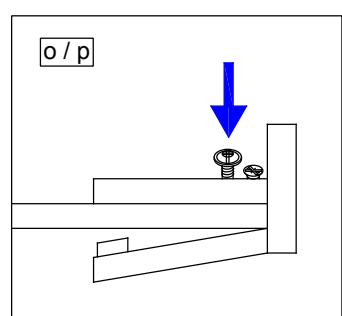
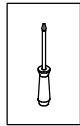

8.2

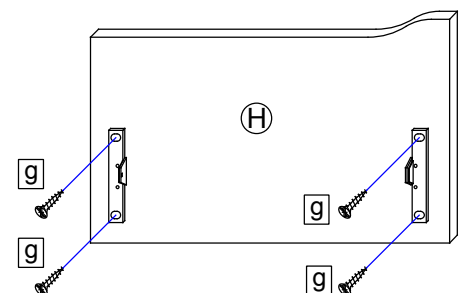

8.1

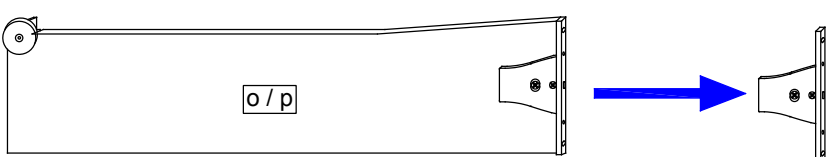

9. 

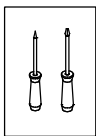

10. 

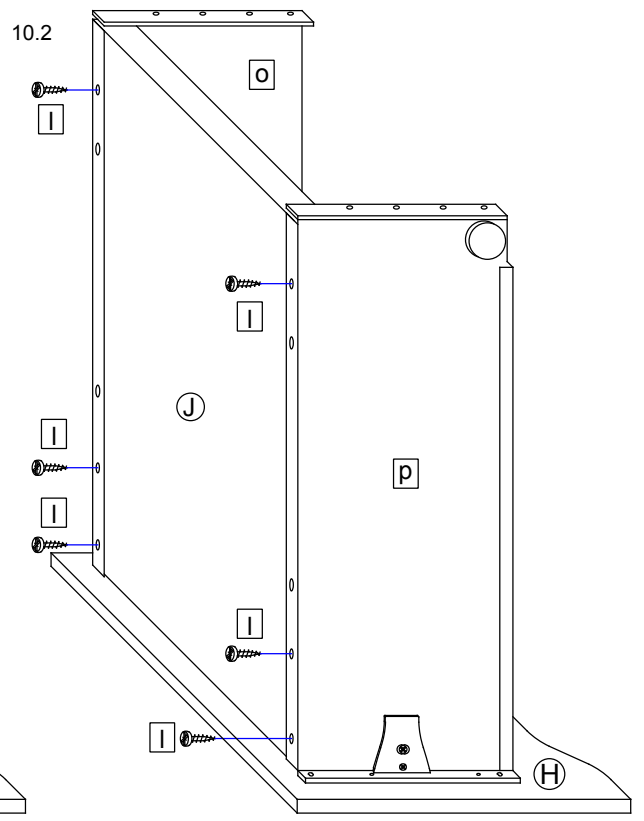
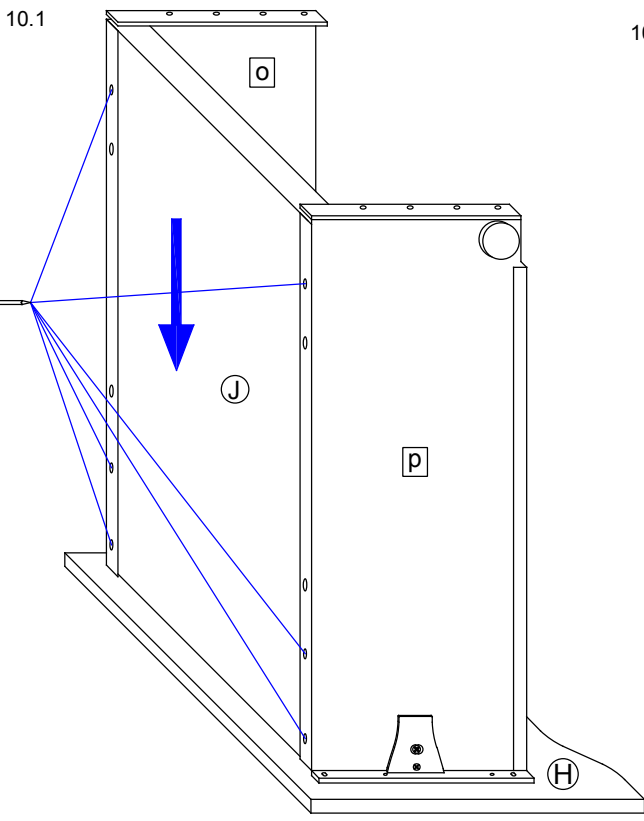

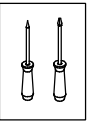
11. 

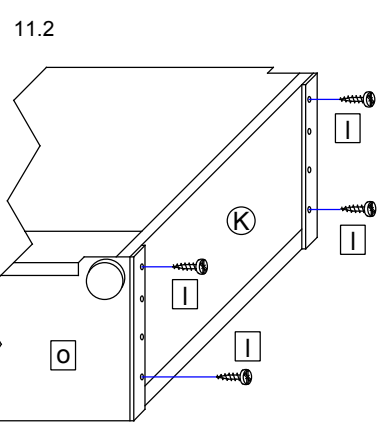
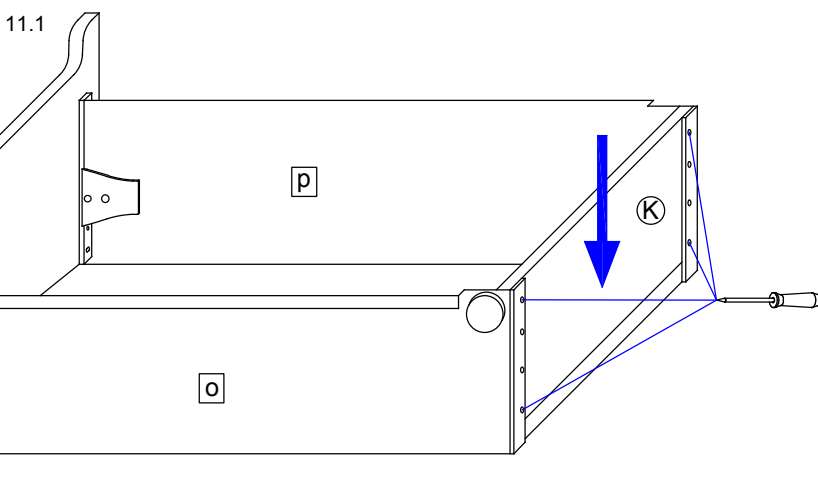

12.

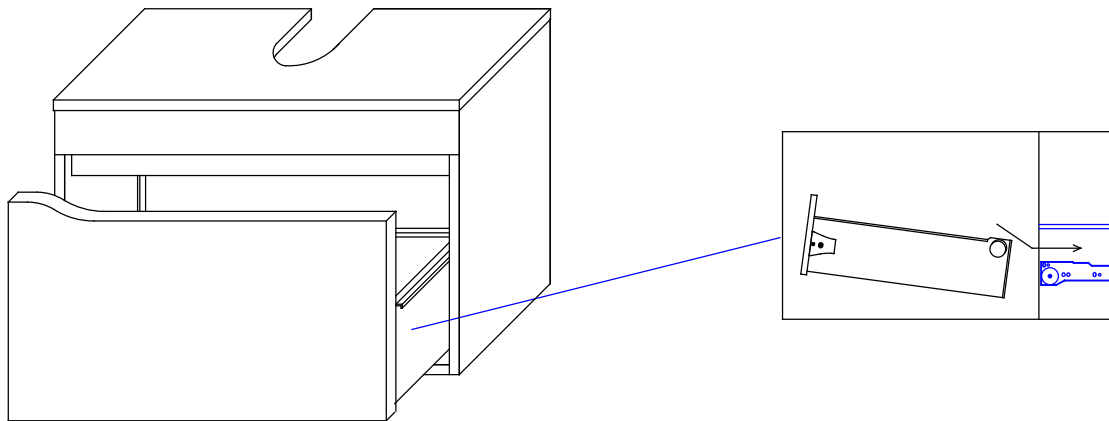

13.

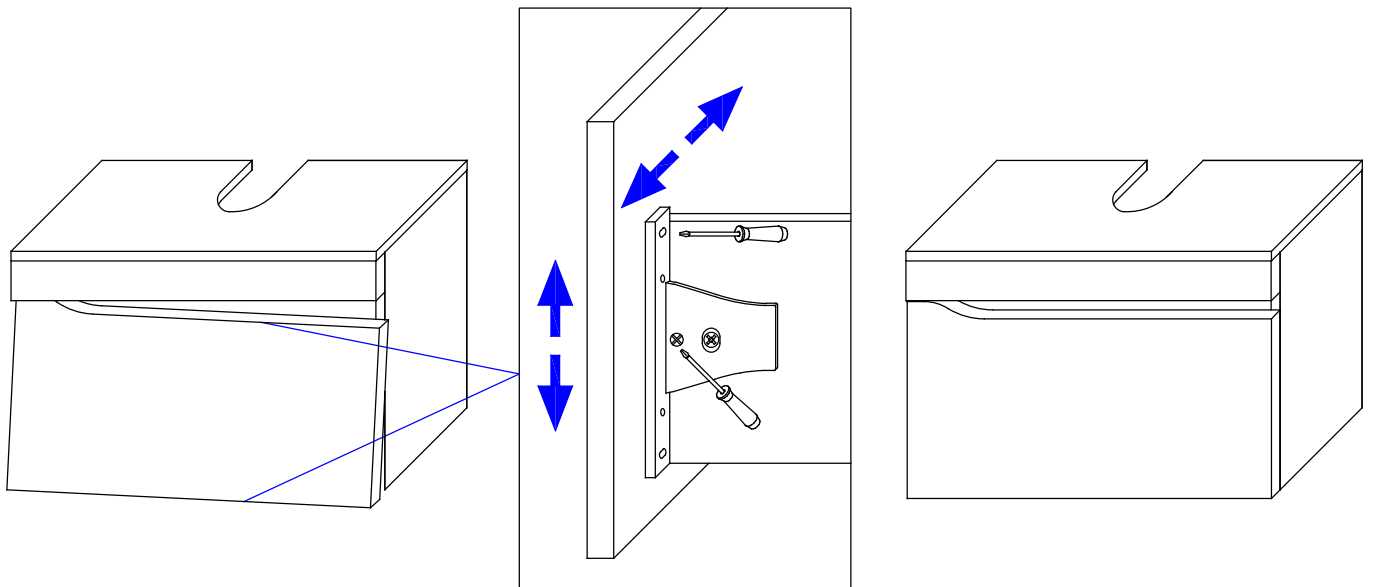
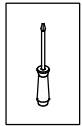

Das Möbel bitte nur mit einem feuchten Tuch reinigen.

pelipal

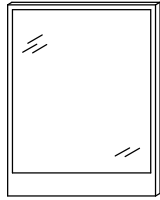

980-__ _5001

980-__ _8001

MOT-NZ0896S1 | A4
Datum 30/08/17

T1

Bitte unbedingt ausfüllen!

Name	
Strasse	
Plz	Ort
Tel.	

T2

Sehr geehrte Kunden,
wir freuen uns, dass Sie sich für ein Produkt aus dem Hause Pelipal entschieden haben. Sollte es trotz aller Bemühungen unsererseits, Ihnen ein qualitativ hochwertiges Möbelstück zu liefern, zu Fehlteilen kommen, schicken Sie bitte dieses ausgefüllte Blatt an

Fax.: **+49 3443/434350**

E-Mail: **ersatzteile@pelipal.de**

Bitte beachten Sie, dass Bauteile über 800mm Länge und 350mm Breite direkt bei Ihrem Möbelhändler zu beanstanden sind. Zur Reklamationsbearbeitung ist es unbedingt erforderlich **die Artikelnummer des Schrankes**, welche auf dem Etikett ersichtlich ist und den Markt, wo das Möbel erworben wurde anzugeben. Außerdem tragen Sie unten bitte die benötigte Stückzahl ein. Viel Spaß mit Ihrem neuen Badmöbel! Ihr Pelipal Team

--

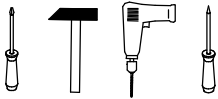





T3

Für den Zusammenbau sind 2 Personen erforderlich.

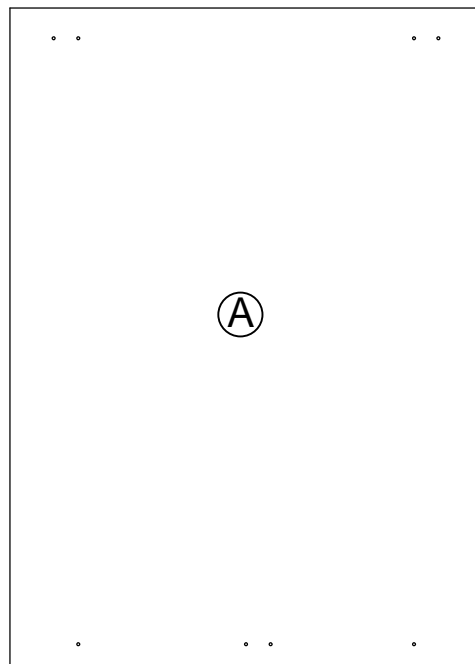
T4

Montage-Richtzeit 1 Stunde

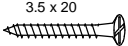

3 x a		Stück	11 x b		Stück	2 x c		Stück	3 x d		Stück		Stück
AUF-001-000060			SCH-SPA-035X020			DTS-20X12X6,5			AUF-001-000020				

980-__ _5001

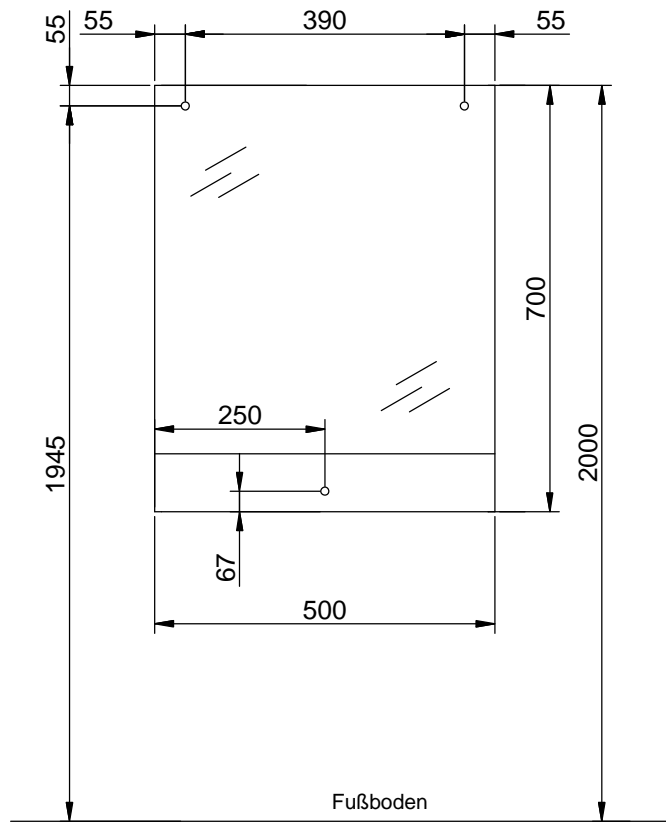

Die Maßangabe der Höhe ist nicht bindend!

980-__ _8001

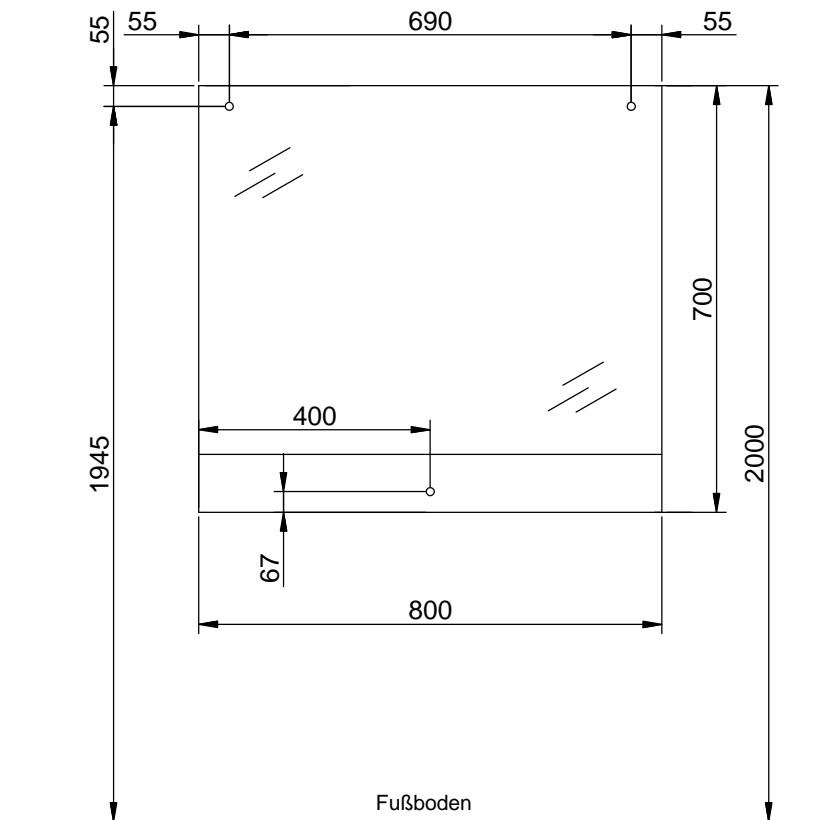

Die Maßangabe der Höhe ist nicht bindend!

1.

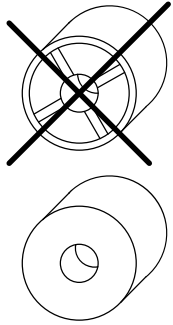
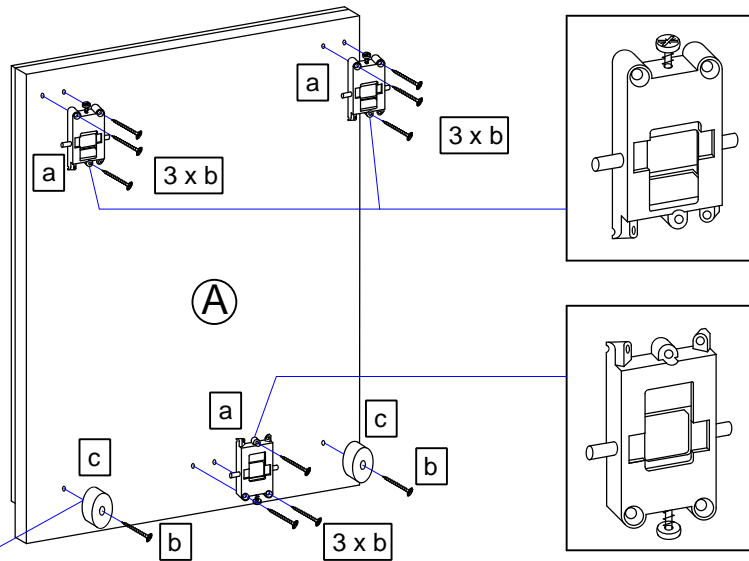
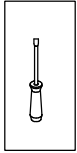

2.

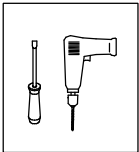

T9 Lassen Sie den Schrank nur durch fachkundige Personen mit für die Wand geeignetem Montagematerialien montieren.

T37 Achtung! Bei fehlerhafter Montage können Schäden durch das Herabstürzen des Spiegels entstehen.

T38 Achten Sie beim Aufhängen des Schrankes darauf, dass der Schrankaufhänger richtig in den Schraubhaken einrastet.

