

Eisenholzschublade mit Glühleisten und Steckdosen Tiroir en bois de fer avec bandes et douilles lumineuses Iron wood drawer with glowing strips and sockets

B021005(140x200)

B021005(160x200)

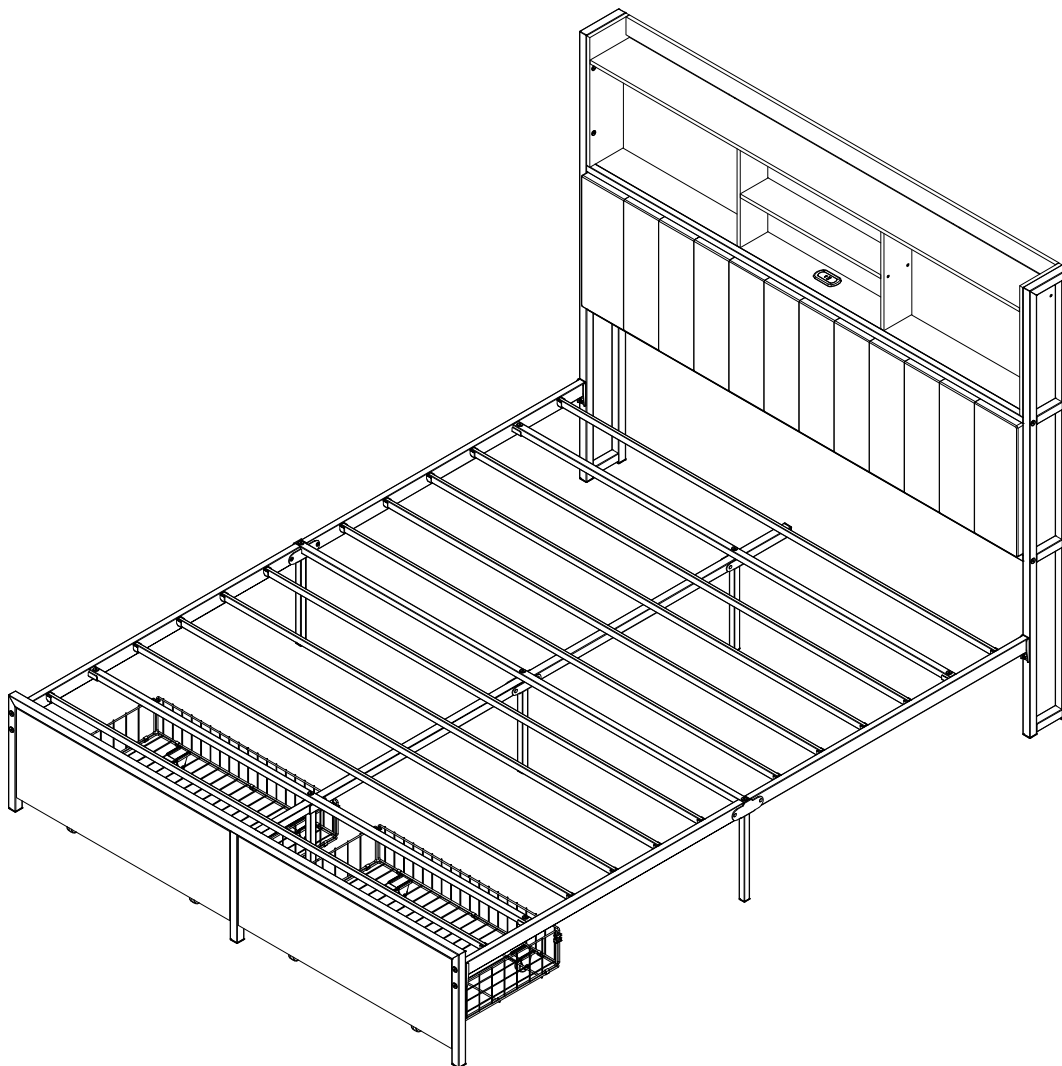

Freundlicher Kundenservice

Zufriedenheitsgarantien: Bei Problemen mit der Montage, der Qualität oder der Rückgabe können Sie sich gerne direkt an uns wenden.

Service client amical

Garanties de satisfaction : si vous rencontrez des problèmes d'assemblage, de qualité ou de retour, n'hésitez pas à nous contacter directement.

Friendly customer Service

Satisfaction guarantee: if you have any problems with assembly, quality or feedback, please feel free to contact us directly.

IMPORTANT/WICHTIG/ATENCION/IMPORTANT/ IMPORTANTE



EN-We recommend 2 or more people to install.
DE-Wir empfehlen, dass die Montage von 2 oder mehreren Personen durchgeführt werden sollte.
ES-Recomendamos realizar el ensamble con 2 o más personas.
FR -Il est recommandé d'effectuer le montage à 2 personne(s) ou plus.
IT -È necessaria la presenza di 2 o più persone per il montaggio di questo prodotto.



EN-The expected assembly time is 1 h.
DE-Die Montagezeit beträgt durchschnittlich 1 h.
ES-El tiempo aproximado de ensamble es de 1 h.
FR-Le temps nécessaire est estimé à 1 h.
IT-Il tempo previsto per il corretto assemblaggio è di 1 h.



EN-Not intended for use by children.
DE-Nicht geeignet für Kinder.
ES-Producto no apto para niños.
FR -Produit non destiné à être utilisé par des enfants.
IT - Questo prodotto non è destinato all'uso da parte dei bambini.



EN-Keep away from fire or other heat sources.
DE-Bitte von Feuer und Hitzequellen fernhalten.
ES -Manténgase alejado de las llamas y otras fuentes de calor.
FR -Tenir à distance des flammes et autres sources de chaleur.
IT -Tenere lontano dal fuoco o da altre fonti di calore.

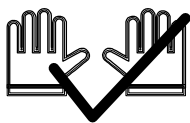



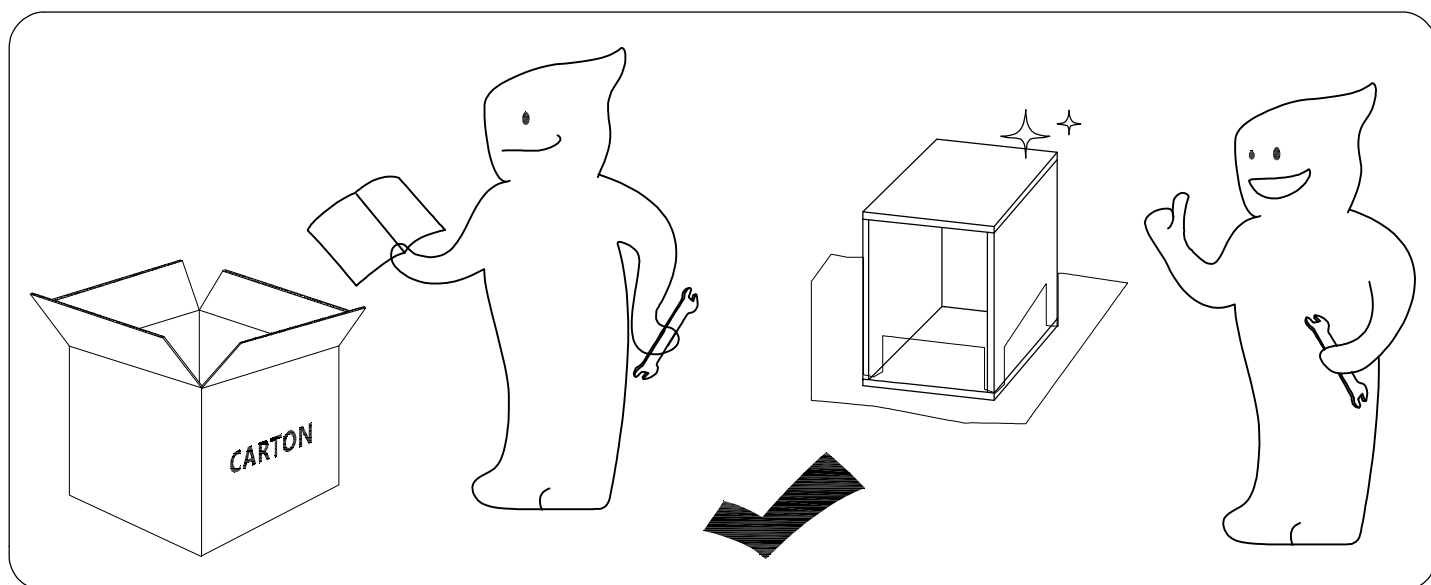
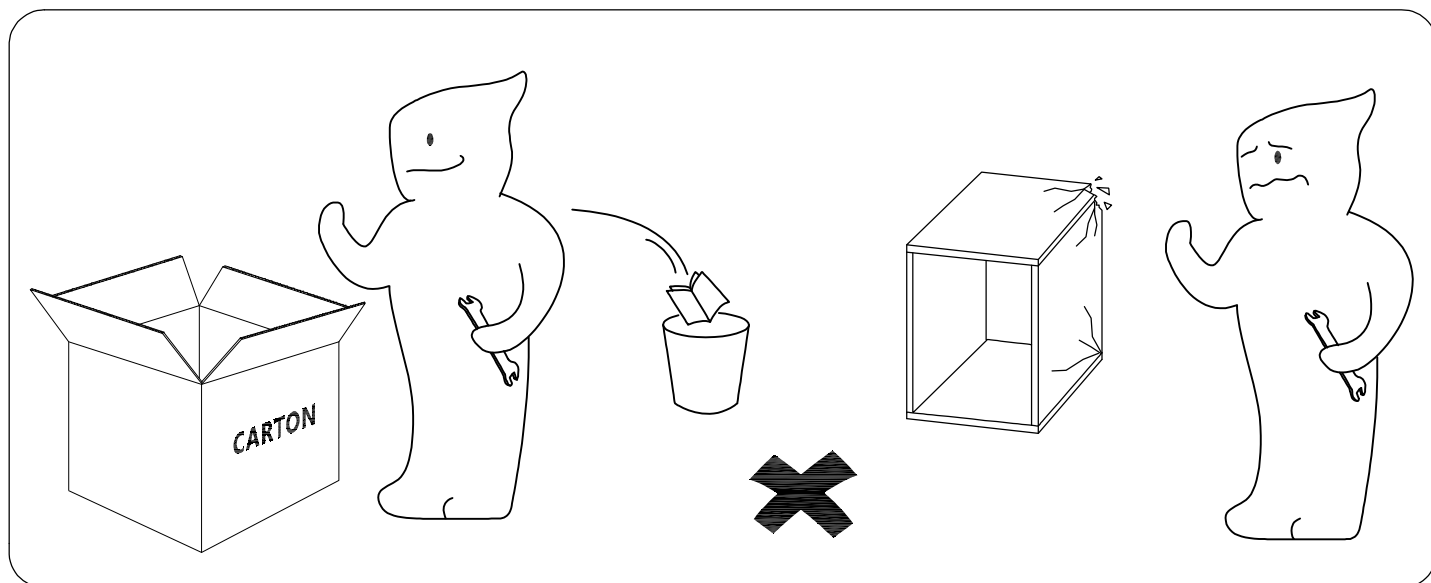

EN-We recommend wearing protective gloves.DE-Wir empfehlen das Tragen von Schutzhandschuhen.ES-Recomendamos el uso de guantes de seguridad.FR-I est recommandé de porter des gants de protection.IT-Per il processo di assemblaggio, consigliamo fortemente l'utilizzo di guanti protettivi.

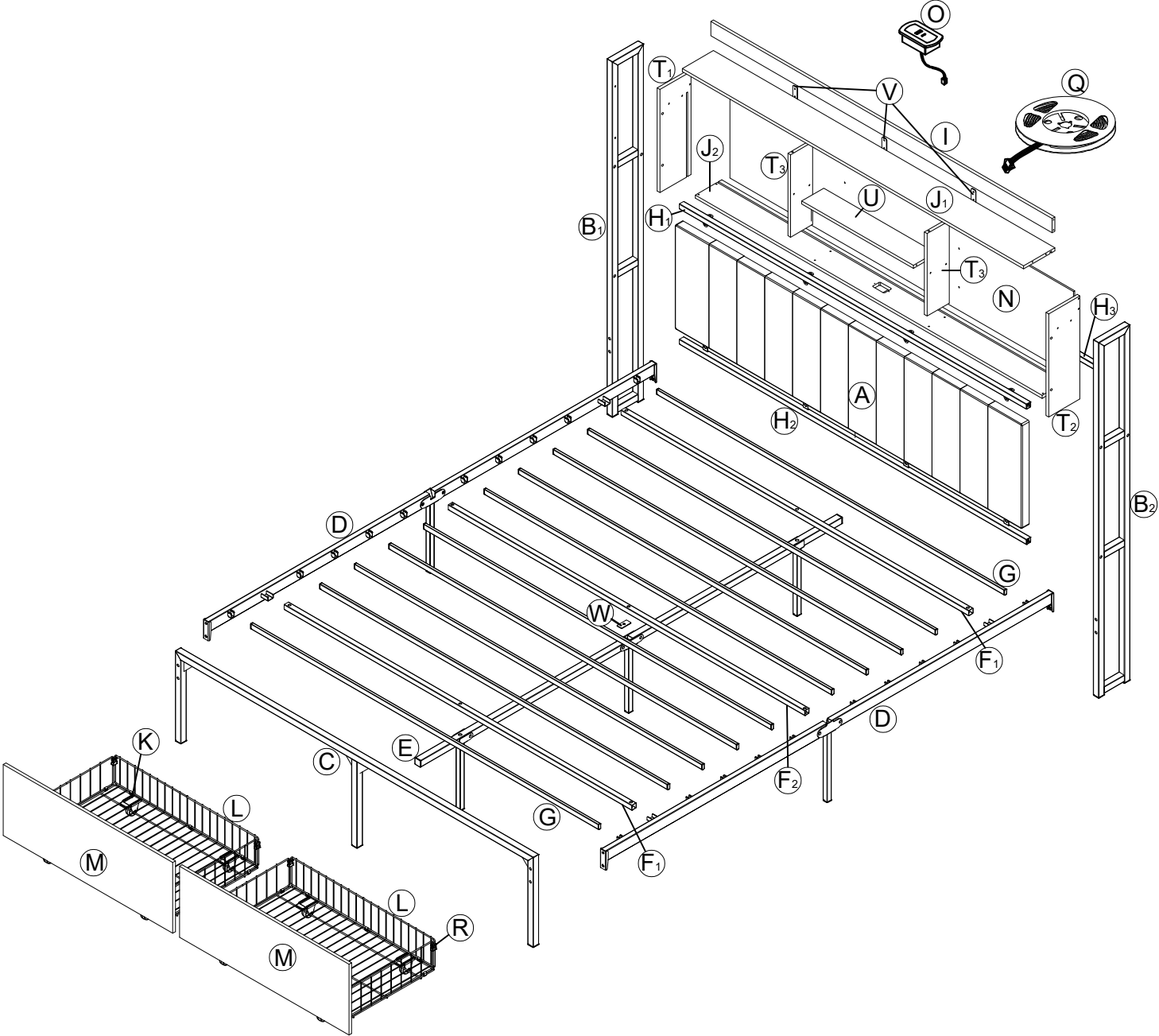
EN - Please follow the instruction manuals and use a pad to avoid damage during assembly.
DE - Bitte folgen Sie der Anleitung und verwenden Sie eine Unterlage, um Beschädigungen bei der Montage zu vermeiden.
ES - Por favor, siga las instrucciones del manual y utilice una cubierta o lona para proteger el producto y el suelo durante la instalación.
FR - Suivez les instructions de la notice et utilisez une couverture ou une bache pour protéger le produit et les sols pendant le montage.
IT - Si prega di consultare il manuale illustrativo durante il montaggio e di utilizzare un cuscinetto per evitare possibili danni.



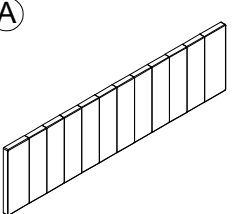
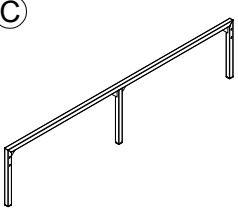
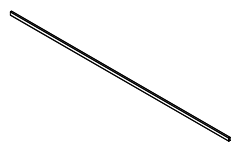
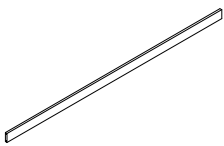
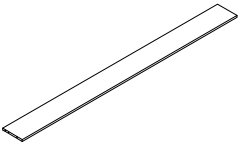
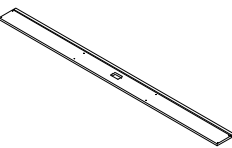
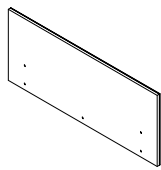
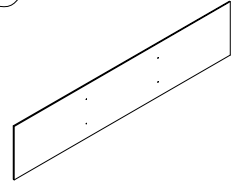

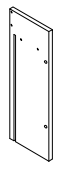

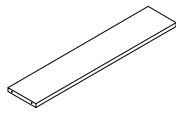





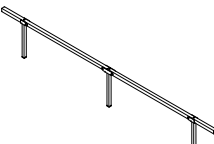
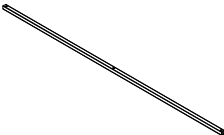
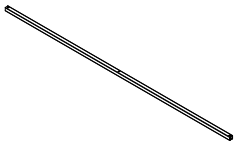
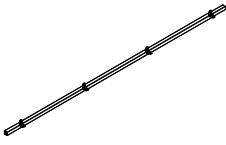
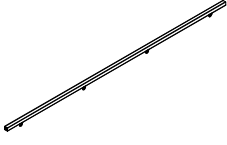
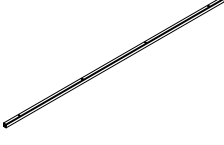
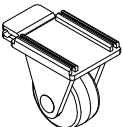
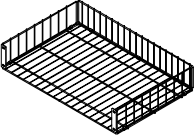

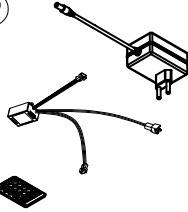

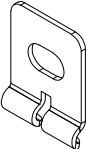

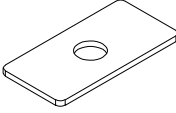
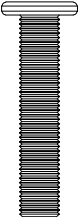



LISTE DER EINZELTEILE
 LISTE D'OBJETS
 PARTS LIST
 PAKET 1/FORFAIT 1/PACKAGE 1



 A 1PCS	 C 1PCS	 G 10PCS	 I 1PCS	 J₁ 1PCS
 J₂ 1PCS	 M 2PCS	 N 1PCS	 T₁ 1PCS	 T₂ 1PCS
 T₃ 2PCS	 U 1PCS			

LISTE DER EINZELTEILE
 LISTE D'OBJETS
 PARTS LIST
 PAKET 2/FORFAIT 2/PACKAGE 2

B₁  1PCS	B₂  1PCS	D  2PCS	E  1PCS	F₁  2PCS
F₂  1PCS	H₁  1PCS	H₂  1PCS	H₃  1PCS	K  8PCS
L  2PCS	O  1PCS	P  1PCS	Q  1PCS	R  4PCS
S  2PCS	V  3PCS	W  1PCS		
1  M8*40 14PCS	2  M8*60 5PCS	3  M8*30 4PCS	4  M6*10 22PCS	5  M6*30 8PCS
6  M3*12 8PCS	7  M5*30 24PCS	8  Ø8*30 4PCS	9  4*80 1PCS	10  L65 1PCS
11  3*80 1PCS				

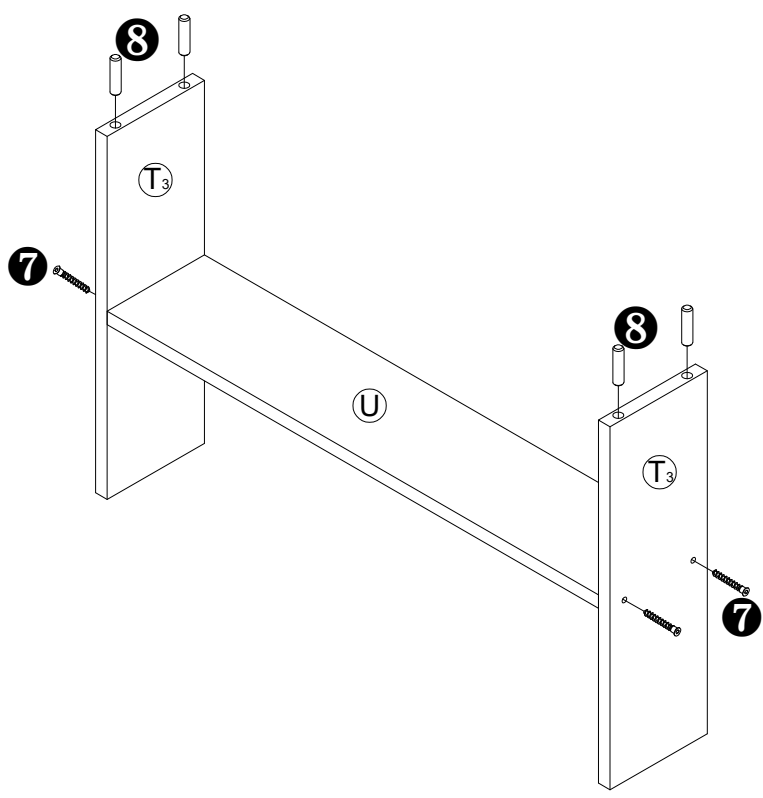
1



8	 Ø8*30	4PCS
7	 M5*30	4PCS

2

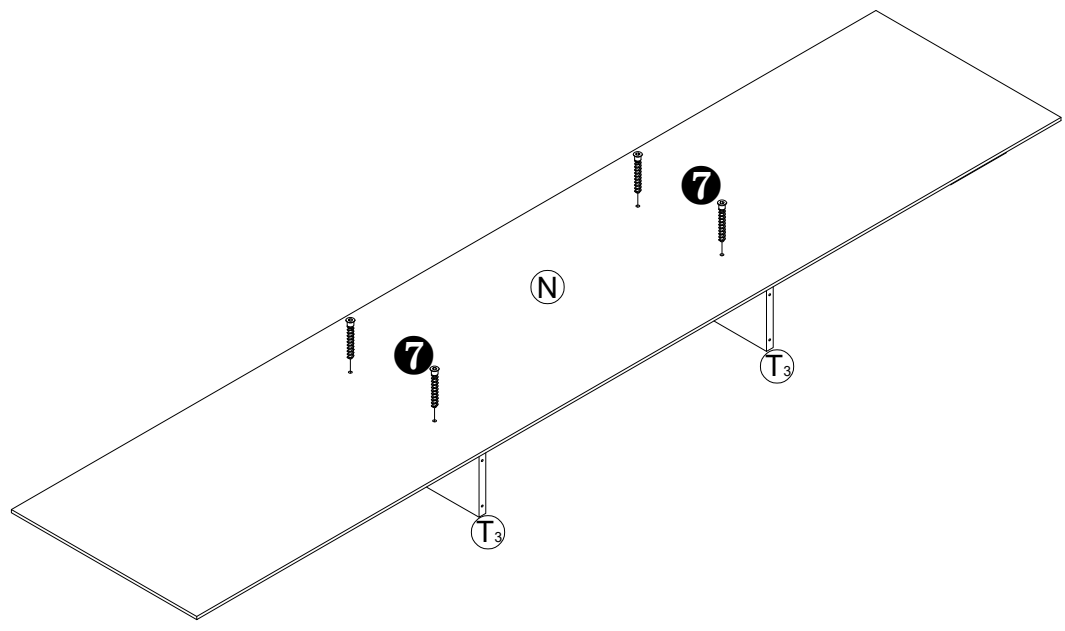

7	 M5*30	4PCS
----------	--	------

3

Kleben Sie das Streifenlicht entlang des Velcro auf das Board.
Collez la bande lumineuse le long du velcro sur la planche.
Attach the striped lights along the Velcro to the board.

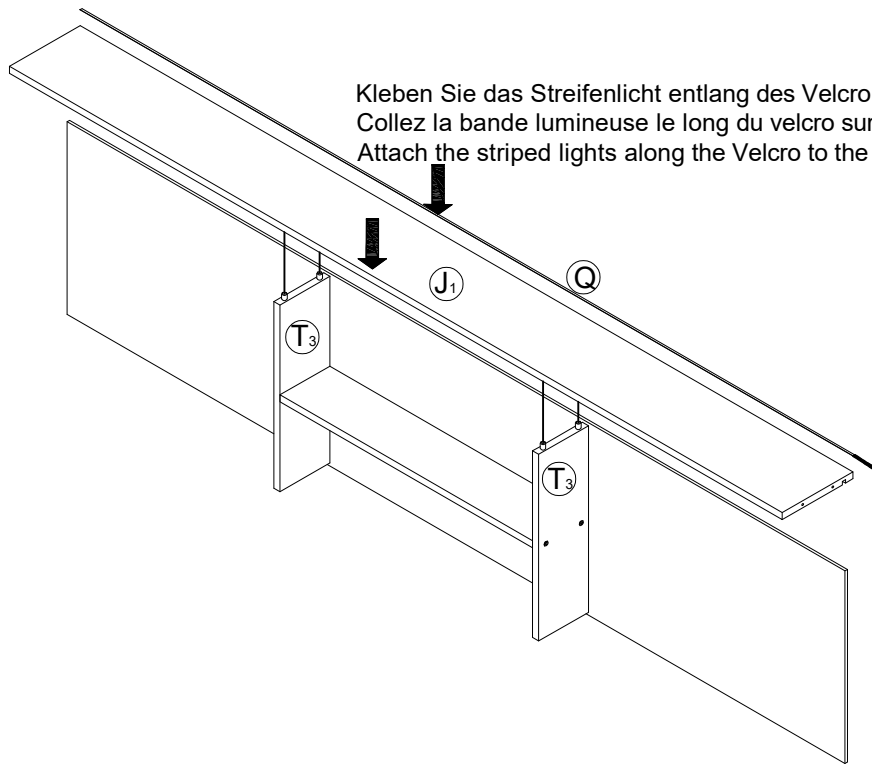

4

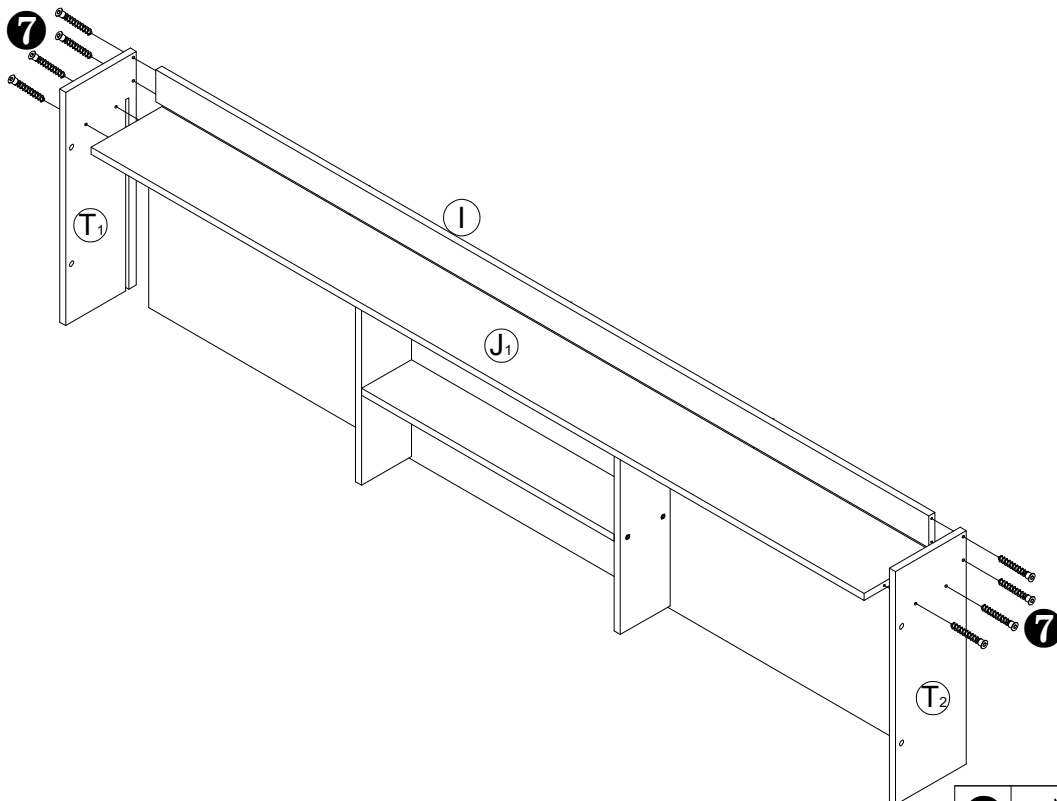

7		8PCS
	M5*30	

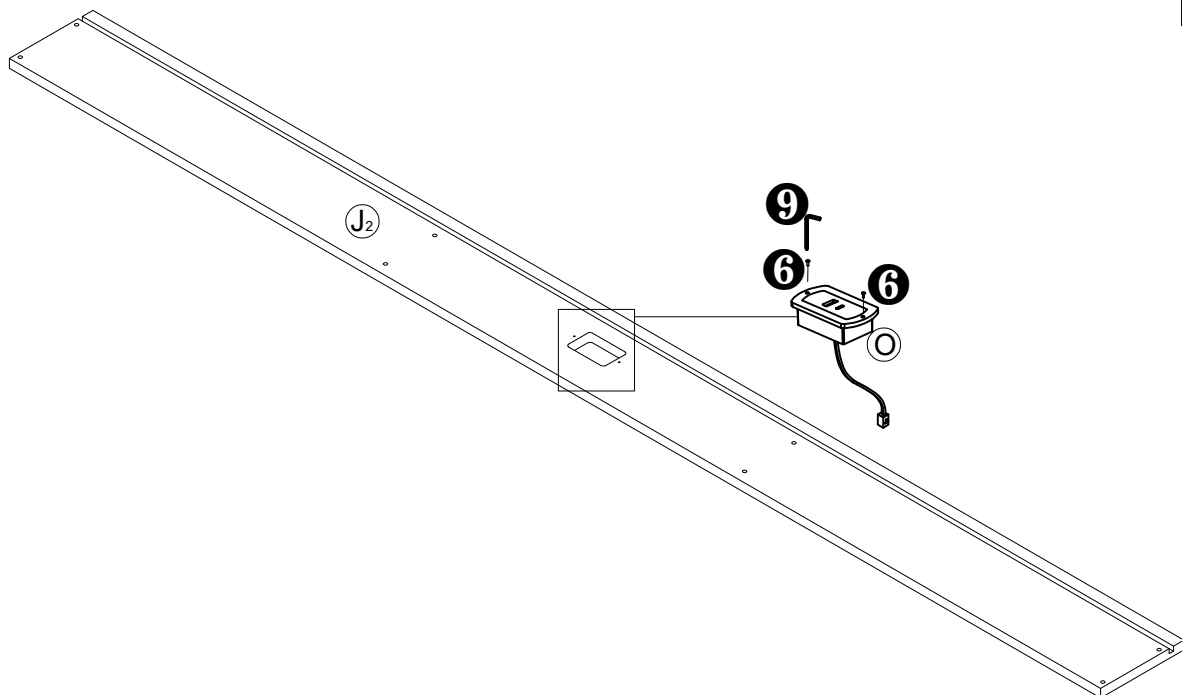

5

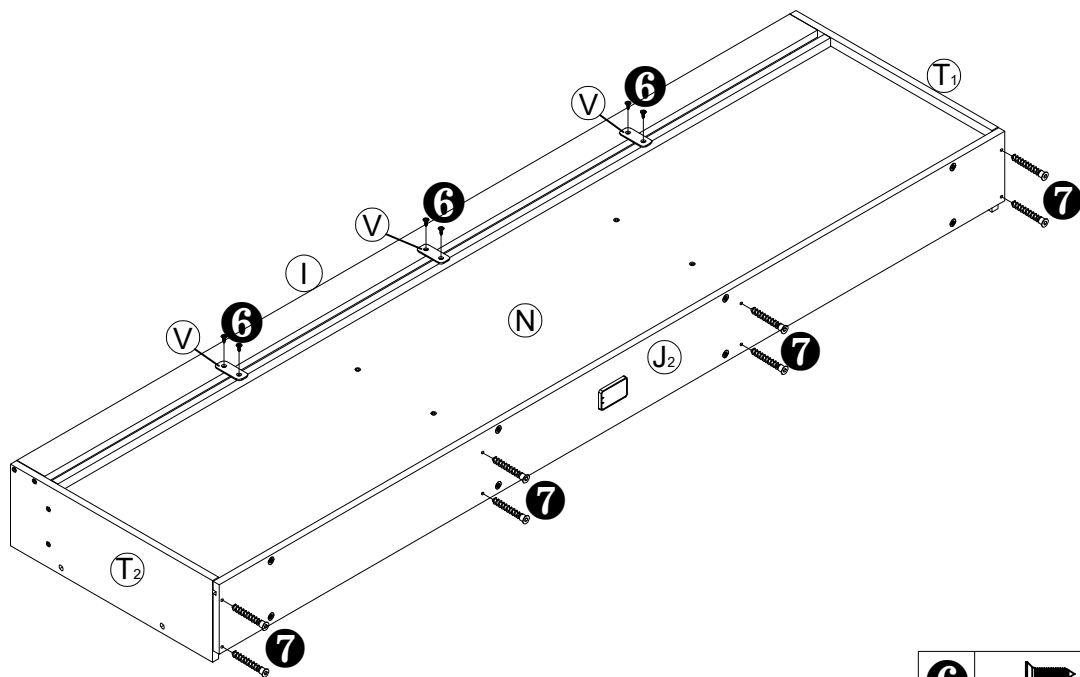

6		2PCS
	M3*12	

6



6		6PCS
	M3*12	
7		4PCS
	M5*30	

7

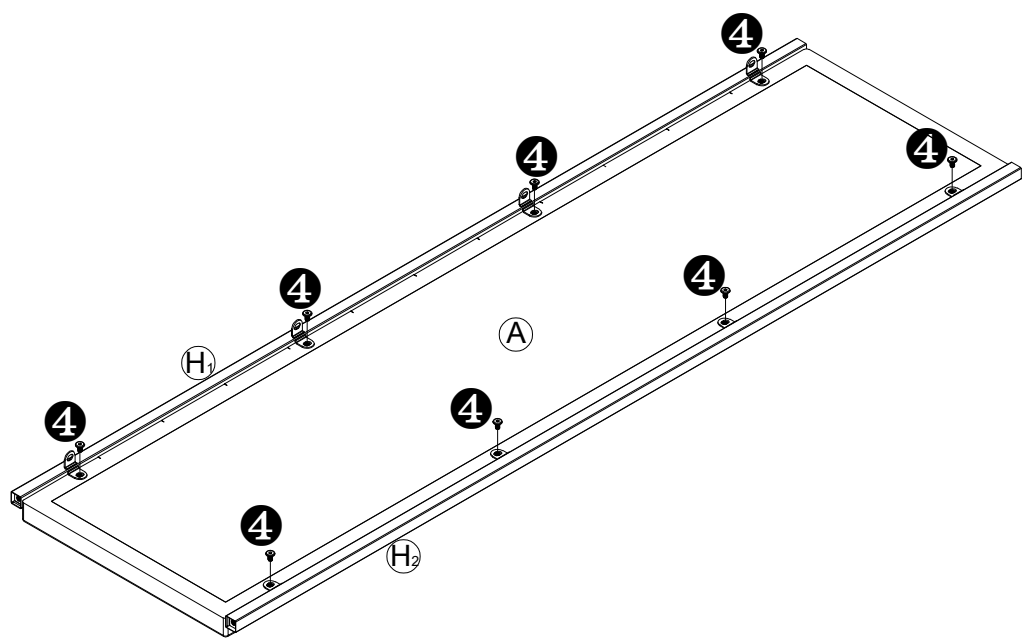

4		8PCS
	M6*10	

8

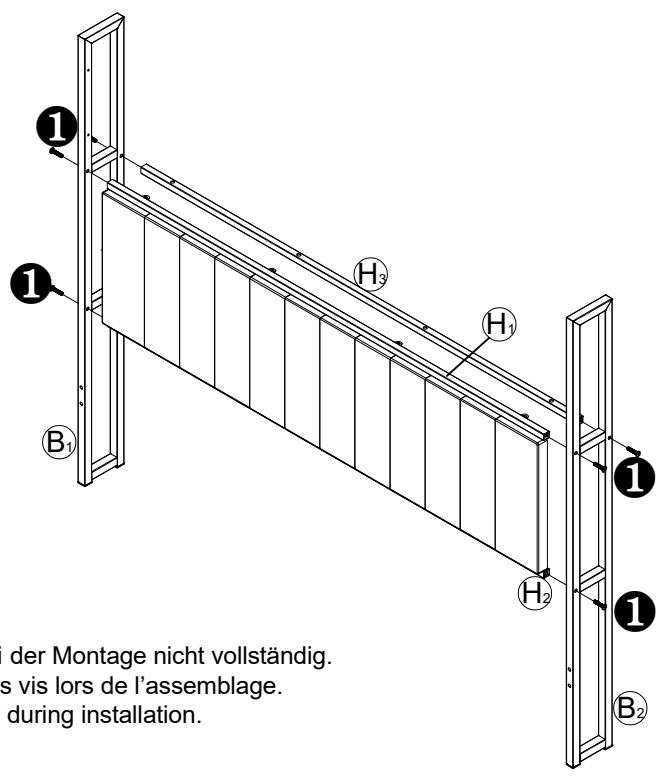

Verriegeln Sie die Schrauben bei der Montage nicht vollständig.
 Ne bloquez pas complètement les vis lors de l'assemblage.
 Do not lock the screw completely during installation.

1		6PCS
	M8*40	

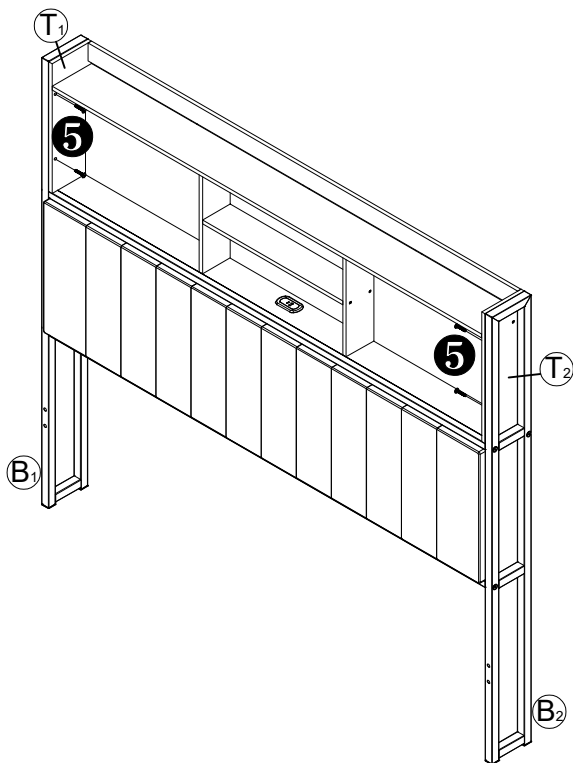

9

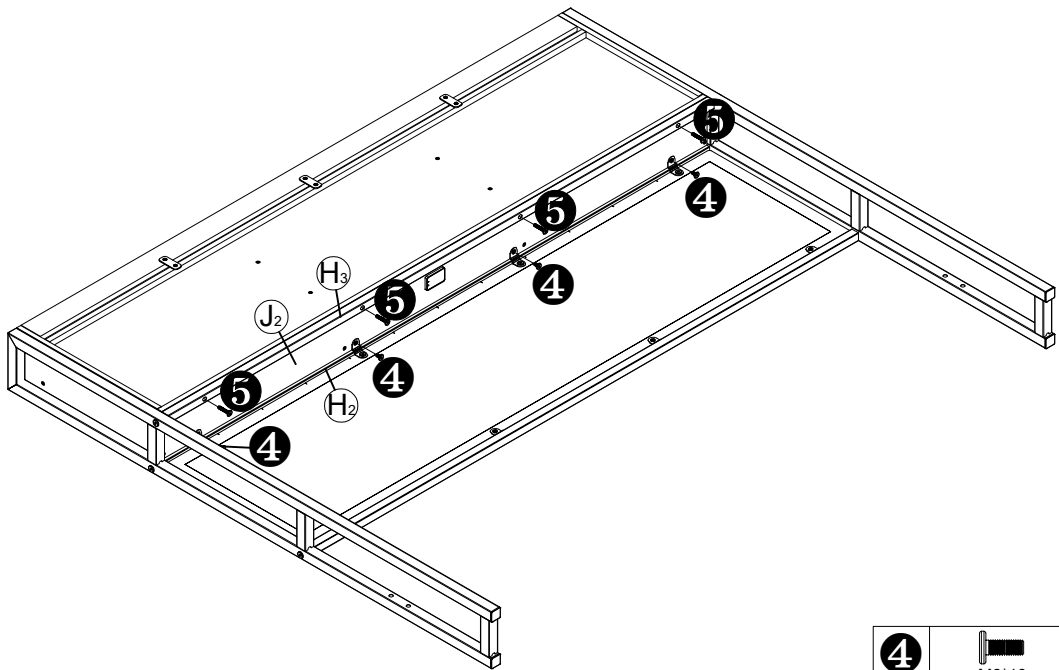

5		4PCS
	M6*30	

10



4		4PCS
	M6*10	
5		4PCS
	M6*30	

11

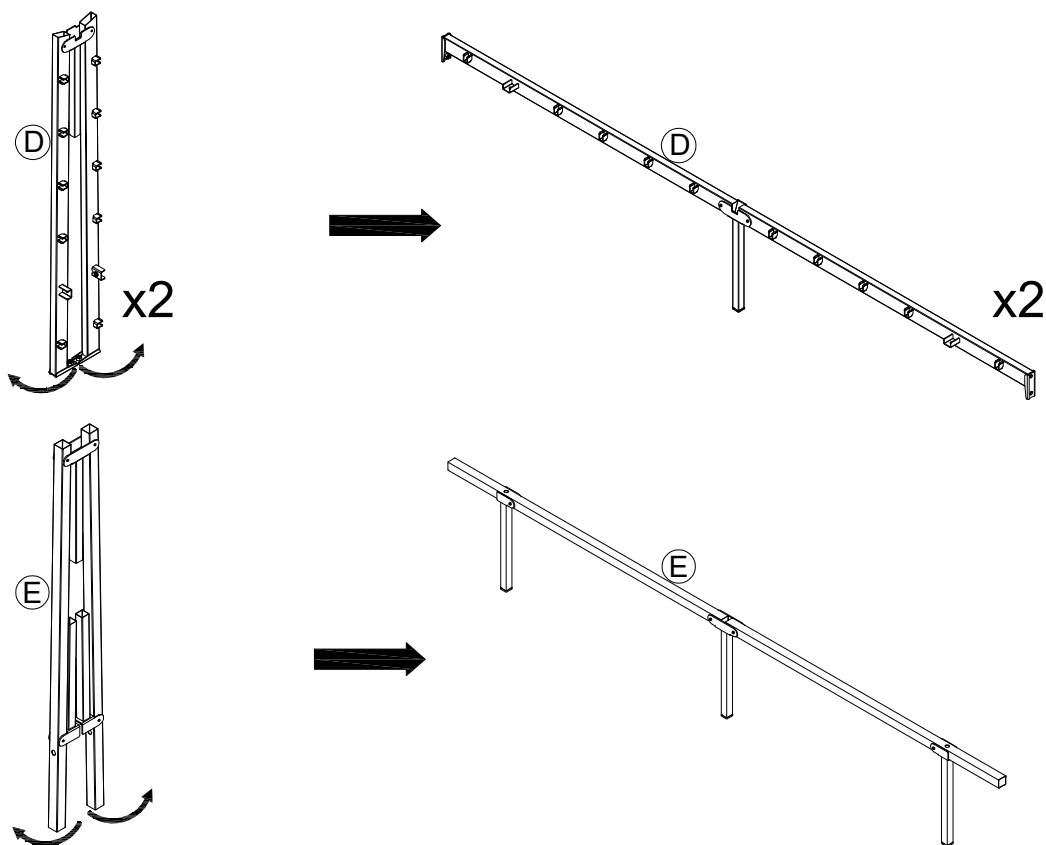

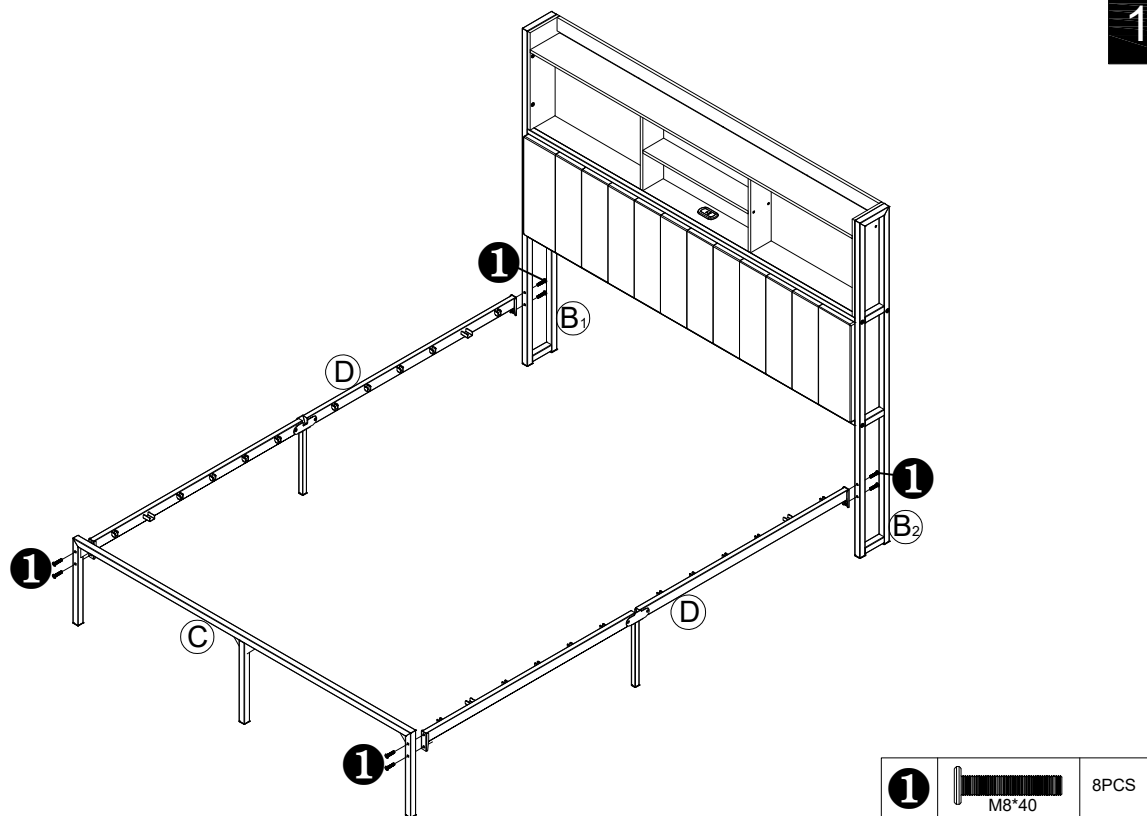

12

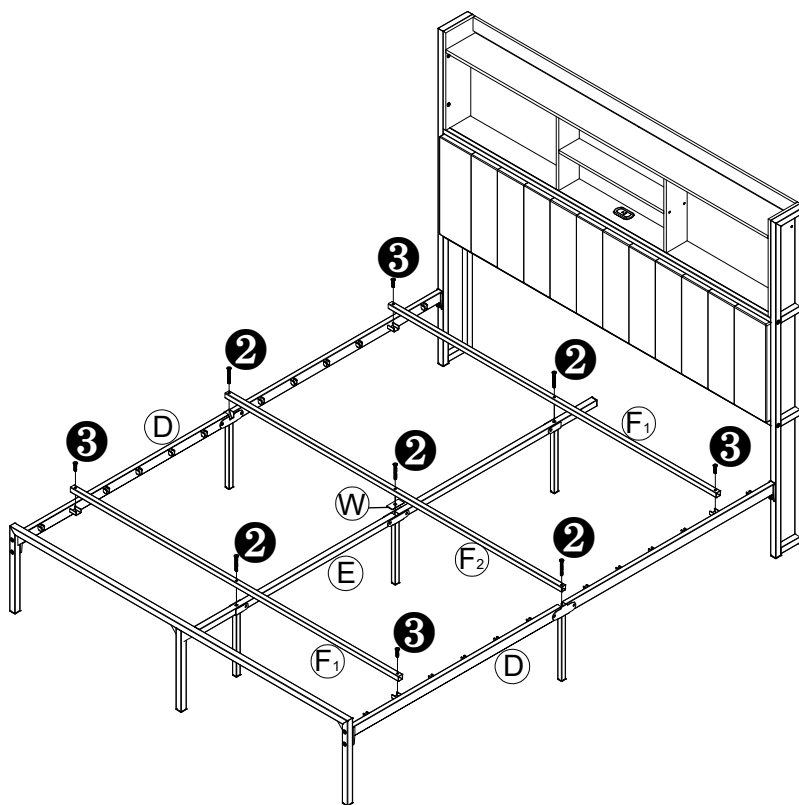

13



3		4PCS
2		5PCS

14

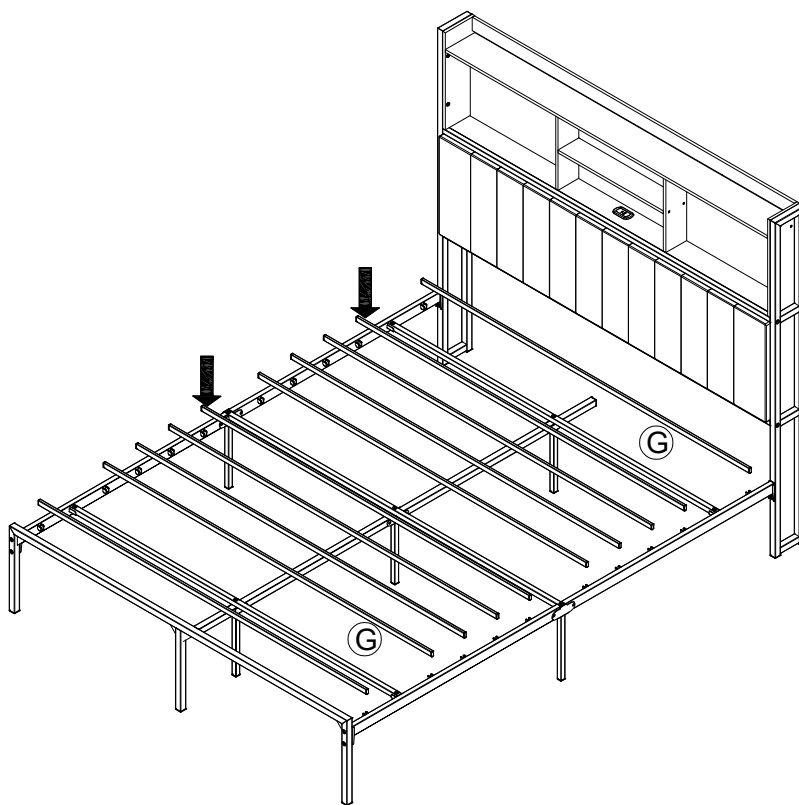

15

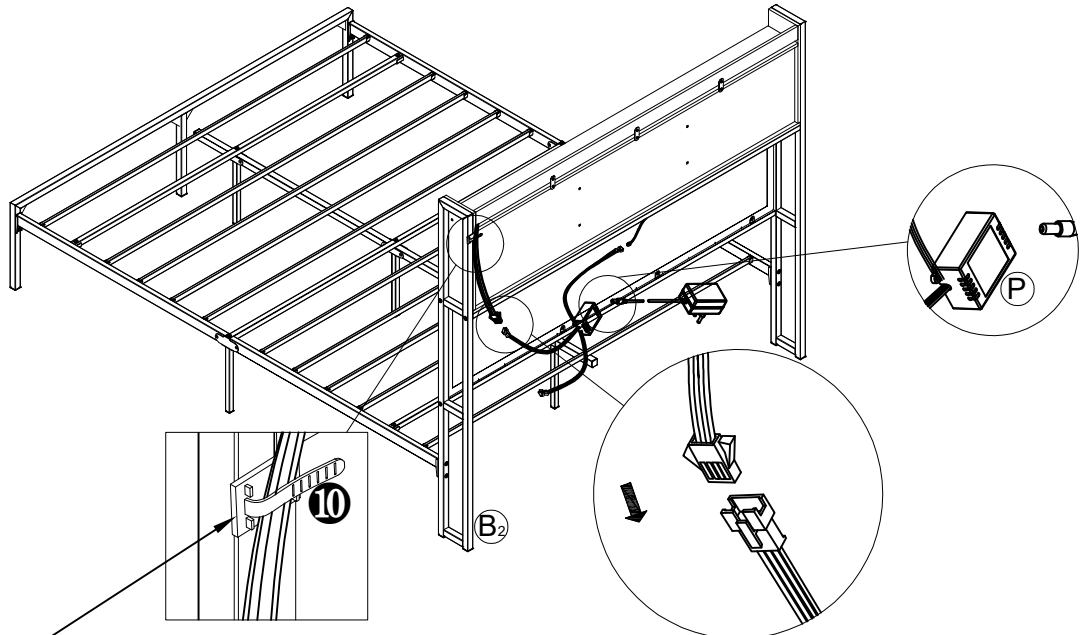

1. Bitte kleben Sie die 10 entsprechend der Abbildung auf das Seitenrohr;
2. Befestigen Sie das B₂ am Seitenrohr um 10
3. Fix 10 it on the side tube

16

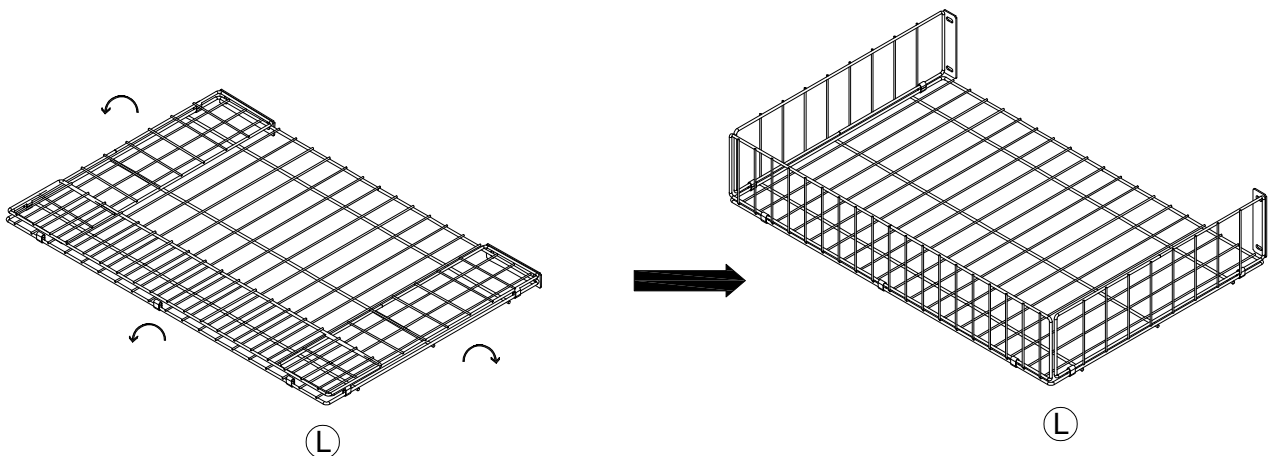

x2

17

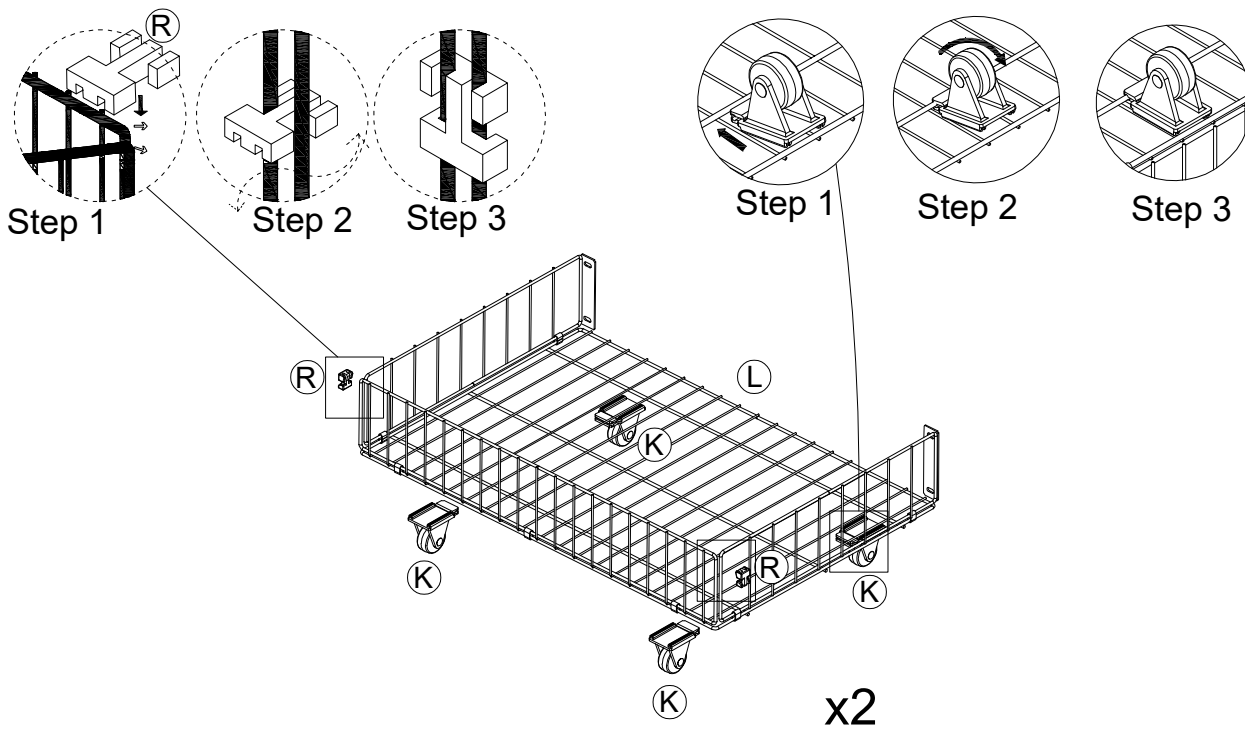

18

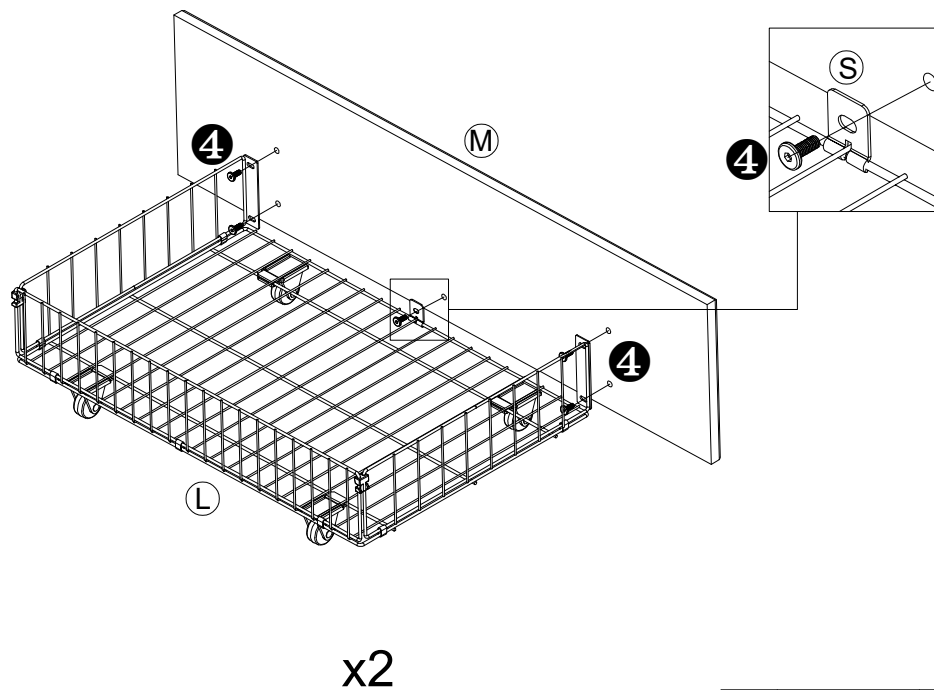

4	 M6*10	10PCS
----------	--	-------

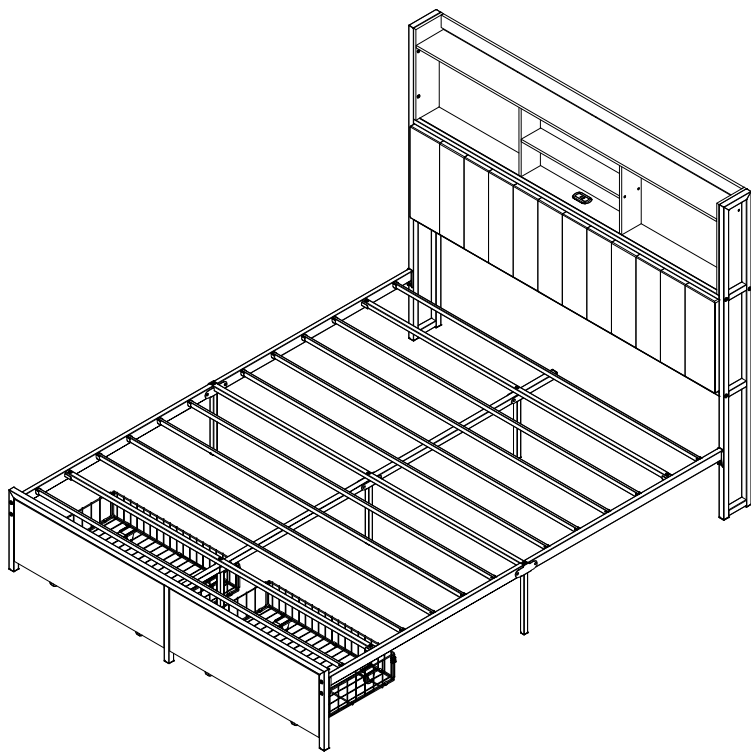
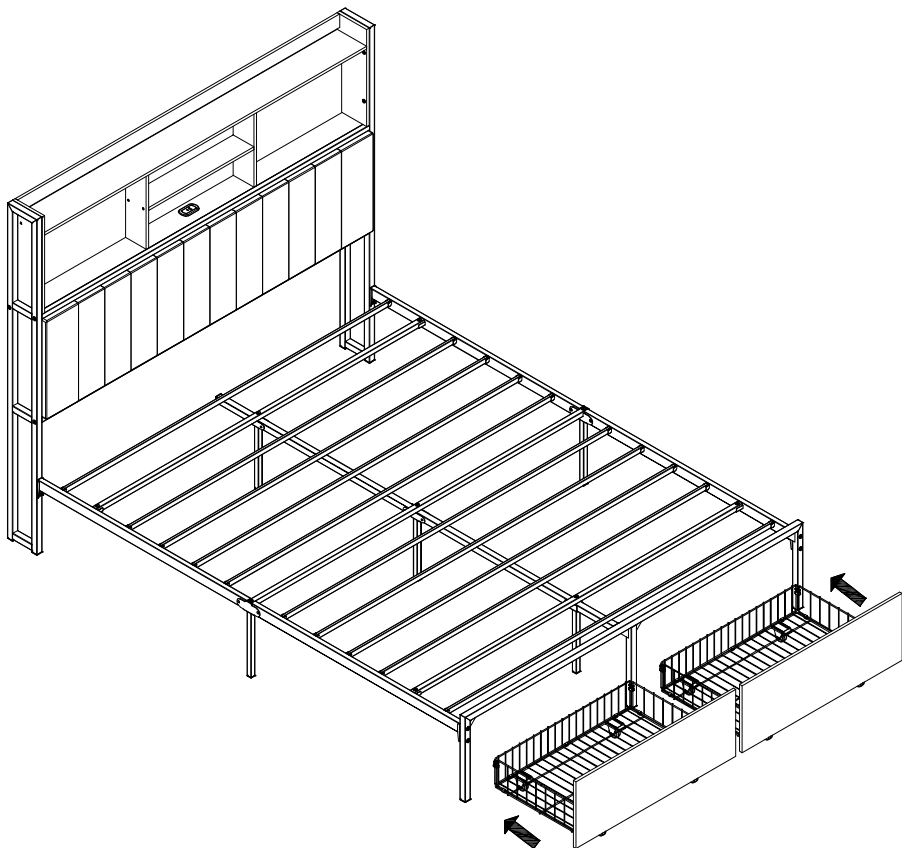

Finished product
Fertiges produkt
Produit fini