

MONTAGEANLEITUNG

Artikelnummer: WF316967RAA

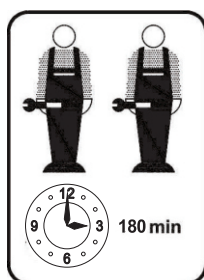

EXPLODED VIEW

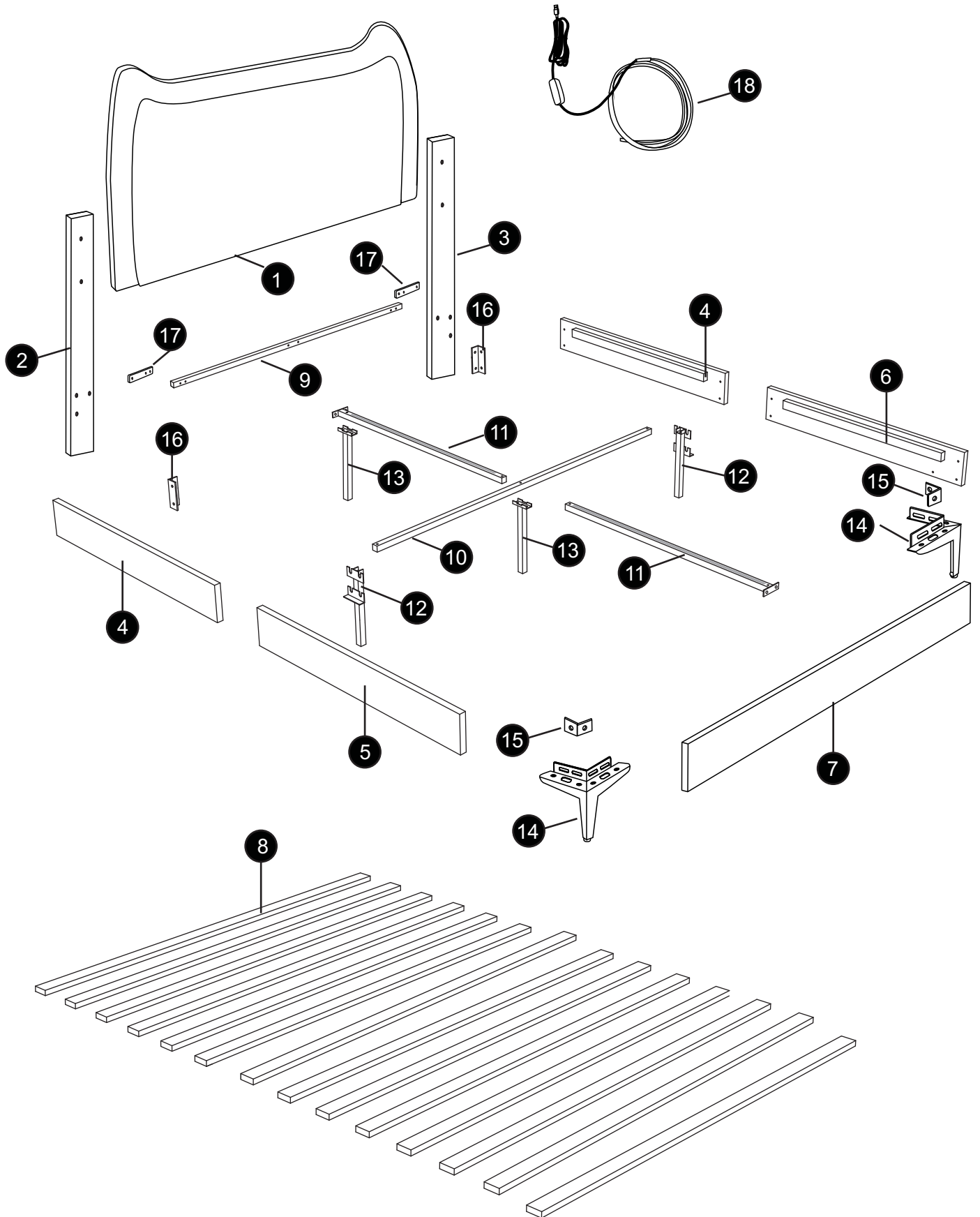

INSTRUCTIONS

IMPORTANT-READ CAREFULLY-RETAIN FOR FUTURE REFERENCE

- a) **WARNING** -Children can become trapped between the bed and the wall, the adjoining pieces of furniture (e.g. cupboards) and the like. To avoid risk of serious injury the distance between the safety barrier and the adjoining structure shall not exceed 75 mm or shall be more than 230 mm.
- b) **WARNING**-Do not use the bed if any structural part is broken or missing; Replacement parts are between requested from the manufacturer or the store.
- c) **WARNING**-Do not climb or wiggle on any non-designated structures.
- d) It is imperative to always follow the installation instructions and manufacturer's use.
- e) The recommended size of the mattress to be used with the bed is **90x200cm**, maximum thickness mattress:**20cm**.
- f) It is necessary to ventilate the room in order to maintain a low level moisture and prevent mold growth in the bed and its periphery.
- g) Joining devices should always be tightened properly and regularly verified. Tighten if necessary.







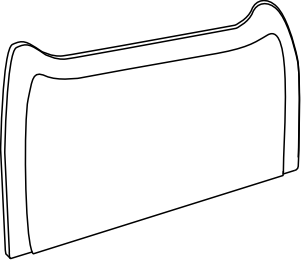

ANLEITUNGEN

WICHTIG - SORGFÄLTIG LESEN - FÜR SPÄTERE VERWENDUNG AUFBEWAHREN

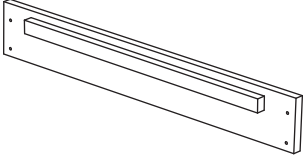
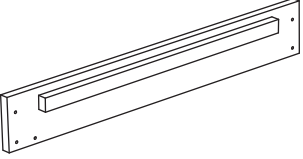
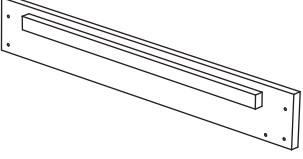
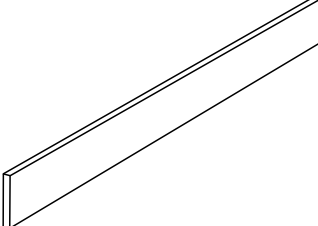
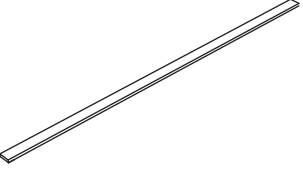
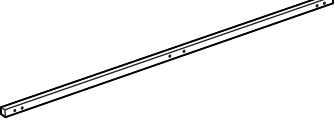
- a) **WARNUNG**-Kinder können zwischen dem Bett und der Wand, den angrenzenden Möbelstücken (z. B. Schränken) und der Lücke eingeklemmt werden. Um die Gefahr schwerer Verletzungen zu vermeiden, darf der Abstand zwischen der Sicherheitsbarriere und der angrenzenden Struktur nicht mehr als 75 mm oder mehr als 230 mm betragen.
- b) **WARNUNG**-Das Bett darf nicht benutzt werden, wenn ein Bauteil gebrochen ist oder fehlt;
Ersatzteile sind beim Hersteller oder im Geschäft anzufordern.
- c) **WARNUNG**-Klettern oder wackeln Sie nicht auf nicht dafür vorgesehenen Strukturen.
- d) Befolgen Sie unbedingt die Installationsanweisungen und die Gebrauchsanweisungen des Herstellers.
- e) Die empfohlene Größe der Matratze für das Bett beträgt **90x200cm**, maximale Dicke der Matratze: **20cm**.
- f) Es ist notwendig, den Raum zu lüften, um die Feuchtigkeit niedrig zu halten und Schimmelbildung im Bett und seiner Umgebung zu verhindern.
- g) Die Verbindungselemente sollten immer richtig angezogen sein und regelmäßig überprüft werden. Ziehen Sie sie gegebenenfalls nach.

PARTS LIST

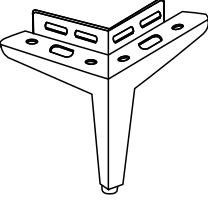
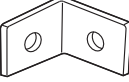
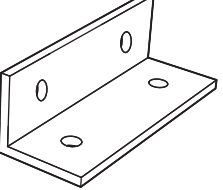
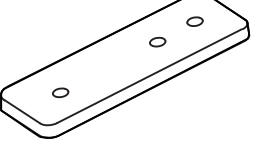
WF316967RAA

1 x1 	2 x1 	3 x1 	4 x2 
5 x1 	6 x1 	7 x1 	8 x14 
9 x1 	10 x1 	11 x2 	12 x2 
13 x2 	14 x2 	15 x2 	16 x2 
17 x2 	18 x1 		

PARTS LIST

WF316967RAA

A: x10

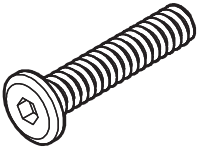

M8*40mm

B: x8

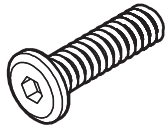

M8*25mm

C: x30



M8*20mm

D: x1

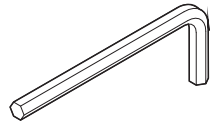

Allen Key M8

ASSEMBLY

Note: Please do not tighten all bolts until the bed is assembled completely.

Hinweis: Bitte ziehen Sie alle Schrauben erst an, wenn das Bett vollständig montiert ist.

STPE 1

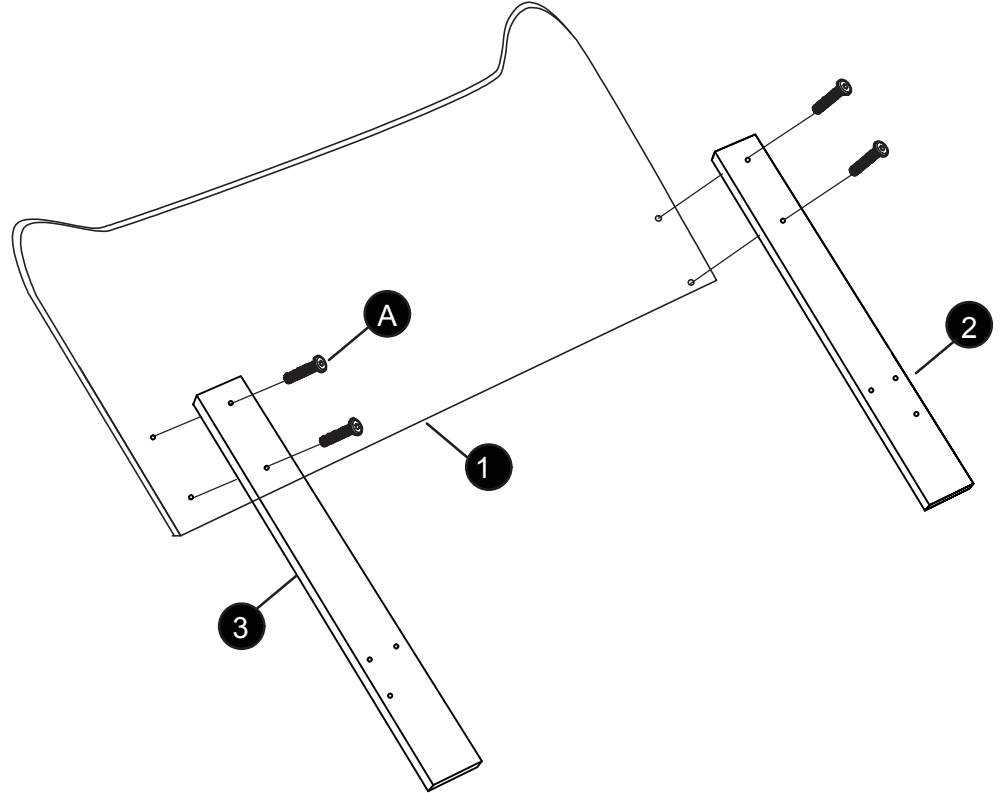

A	 M8*40mm	4
---	---	---

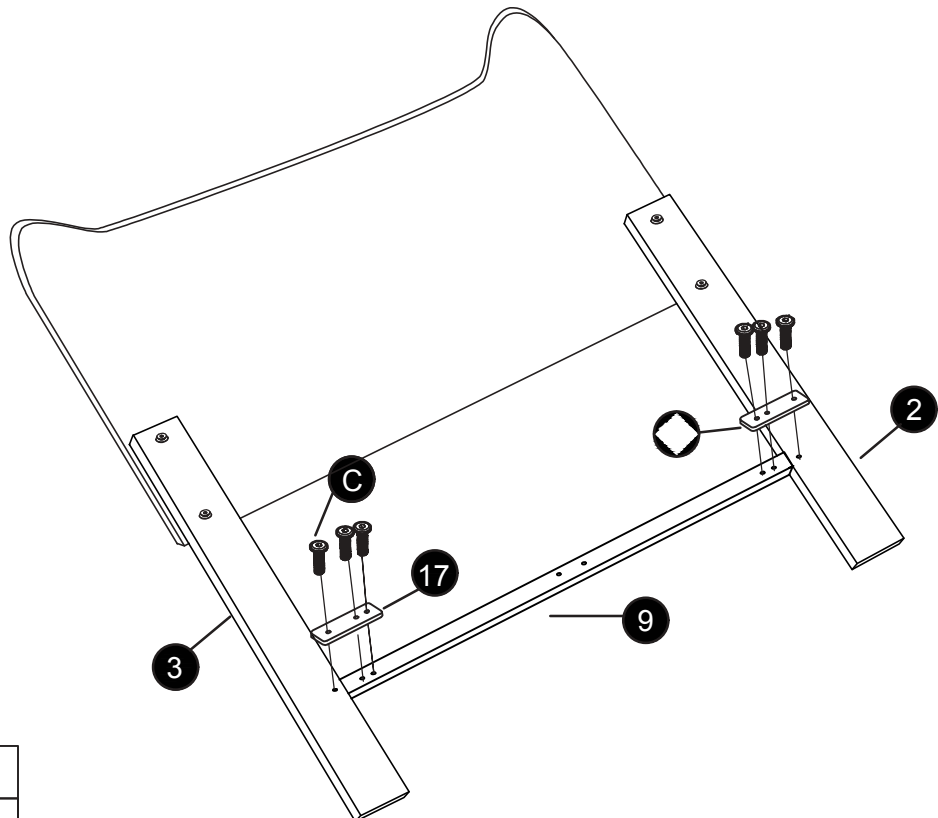

STPE 2

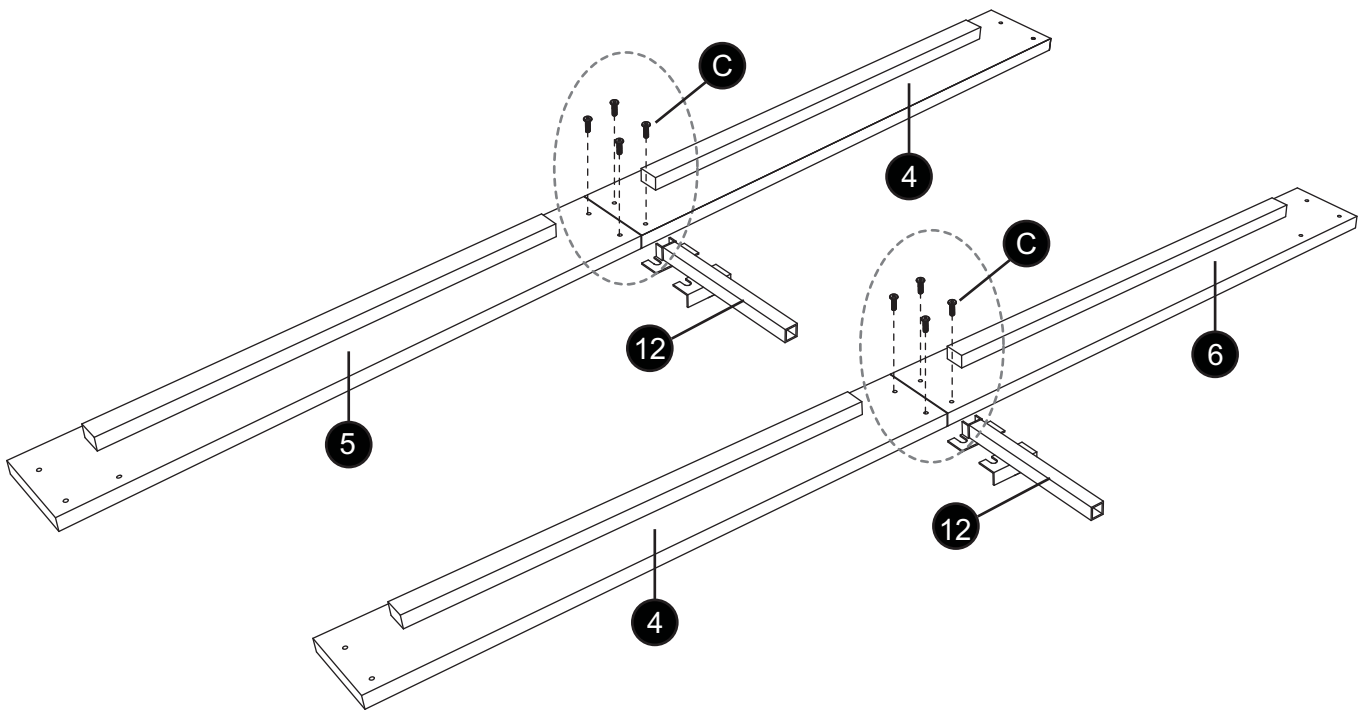
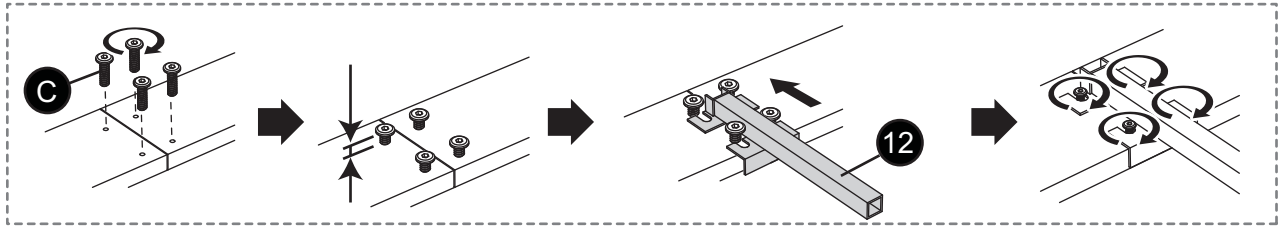

17		2
C	 M8*20mm	6

STPE 3



12		2
C	 M8*20mm	8

STPE 4

Left

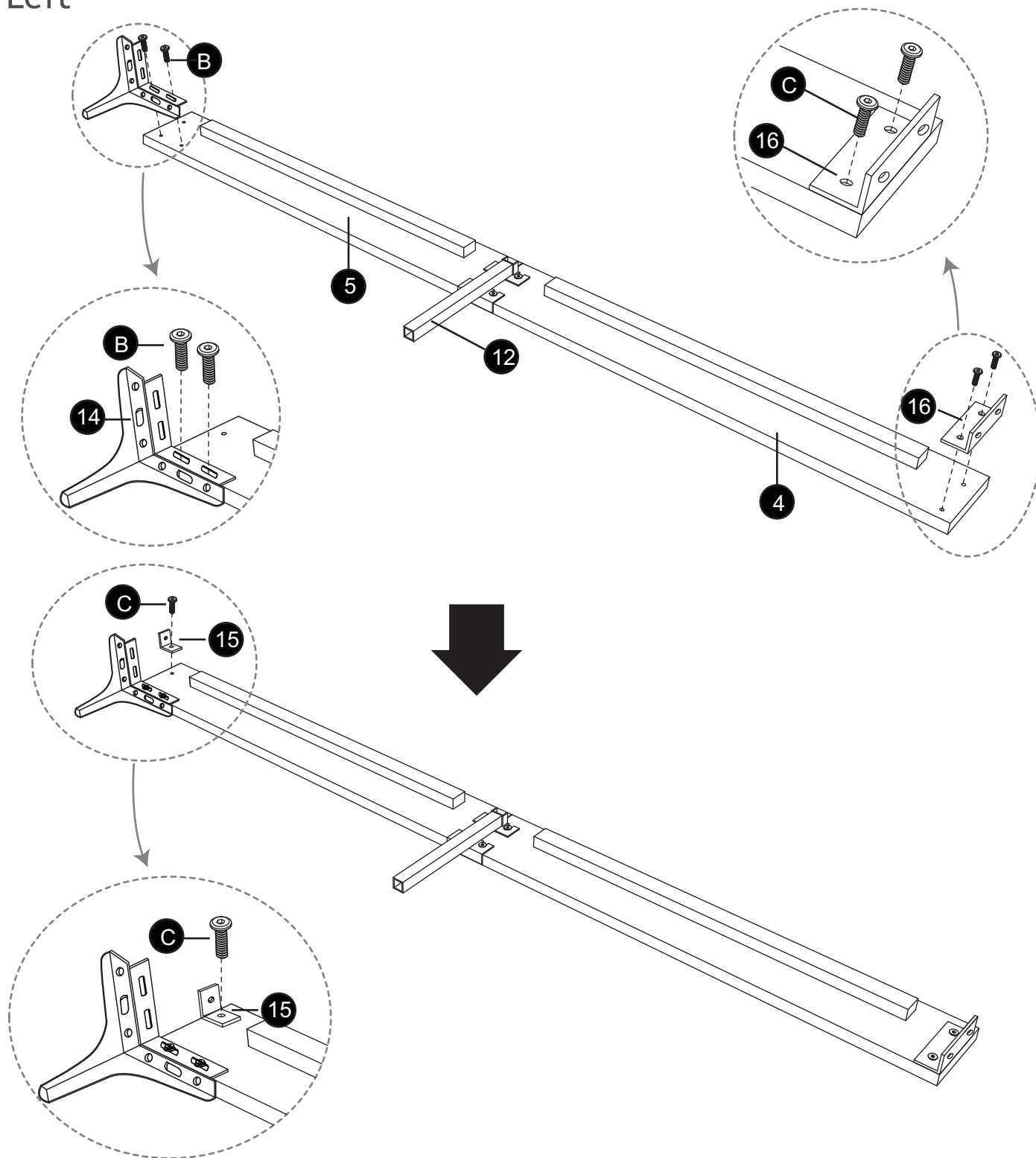

14		1
15		1
16		1
B	M8*25mm	2
C	M8*20mm	3

STPE 5

Right

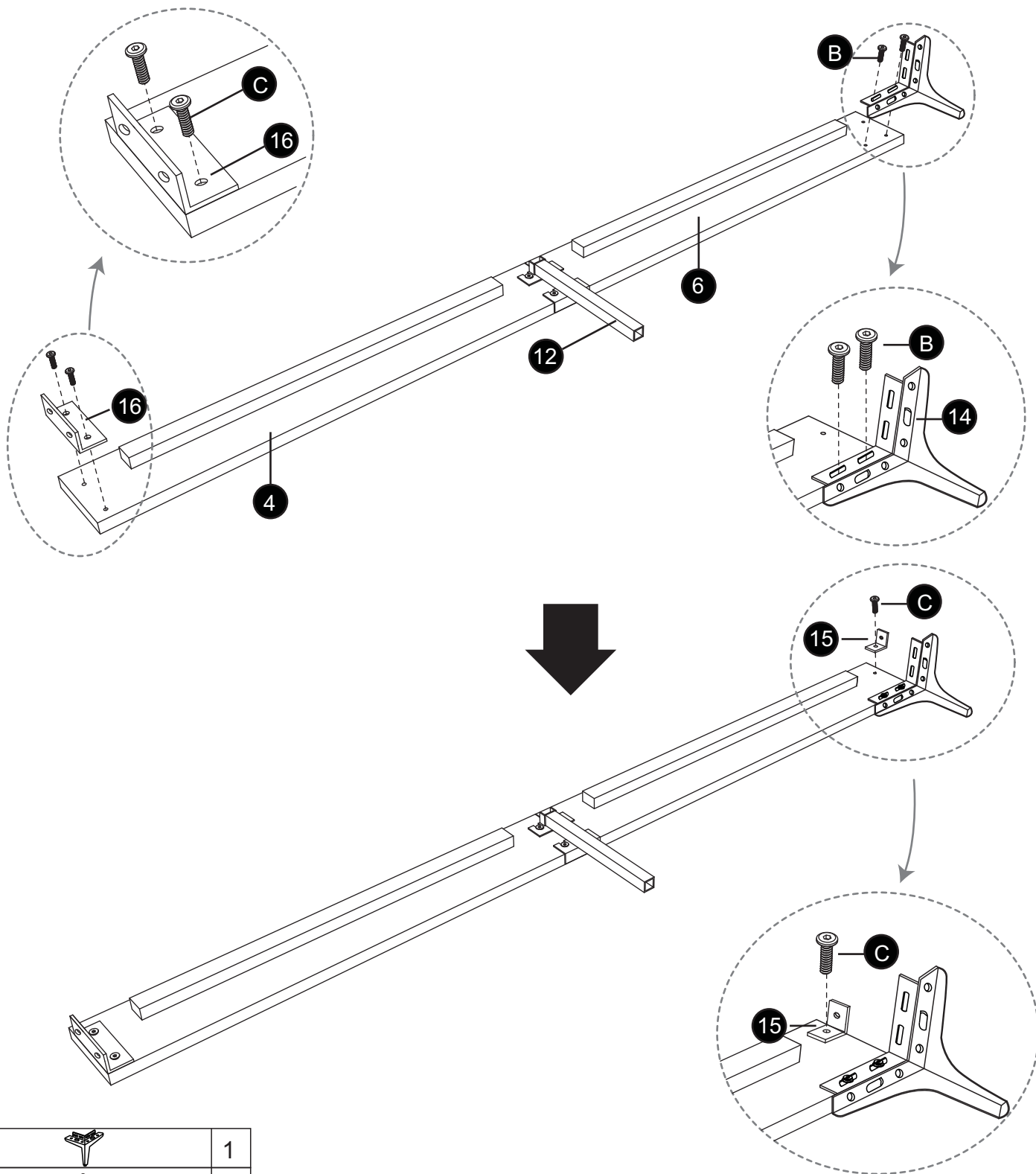

14		1
15		1
16		1
B	M8*25mm	2
C	M8*20mm	3

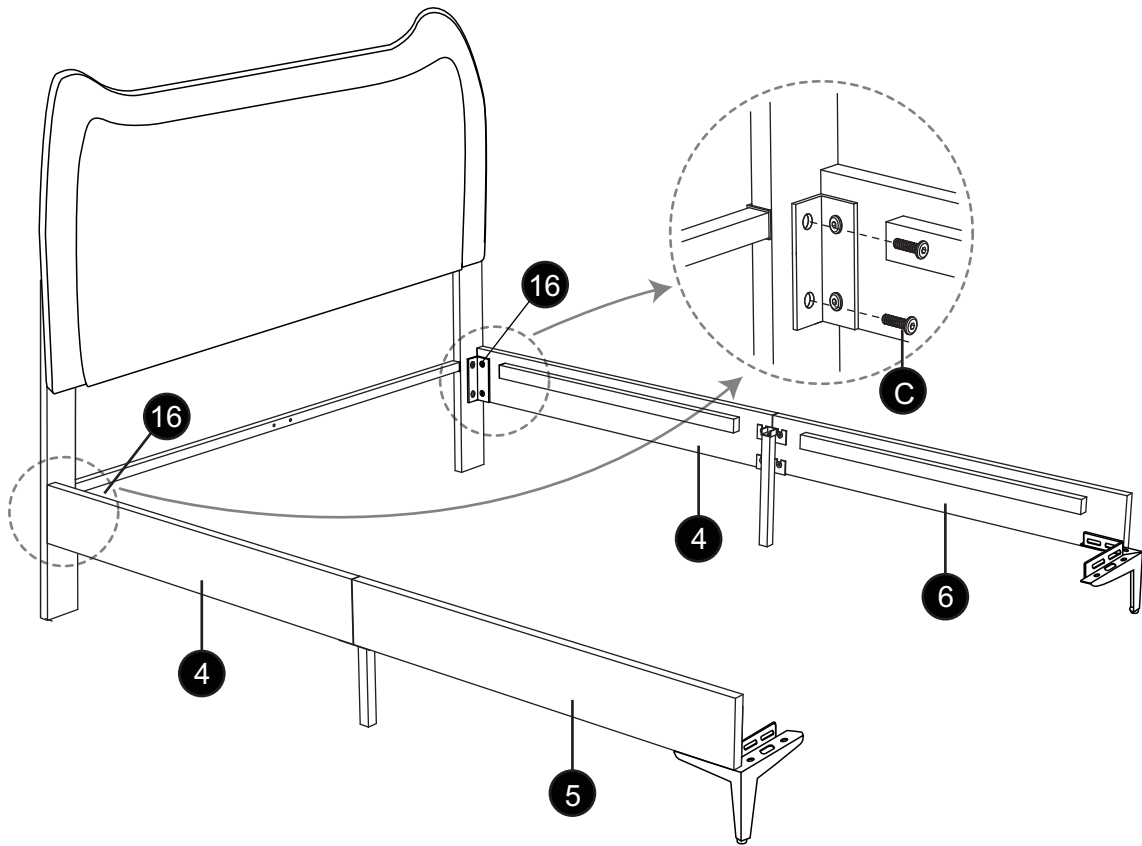

STPE 6



C		M8*20mm	4
---	---	---------	---

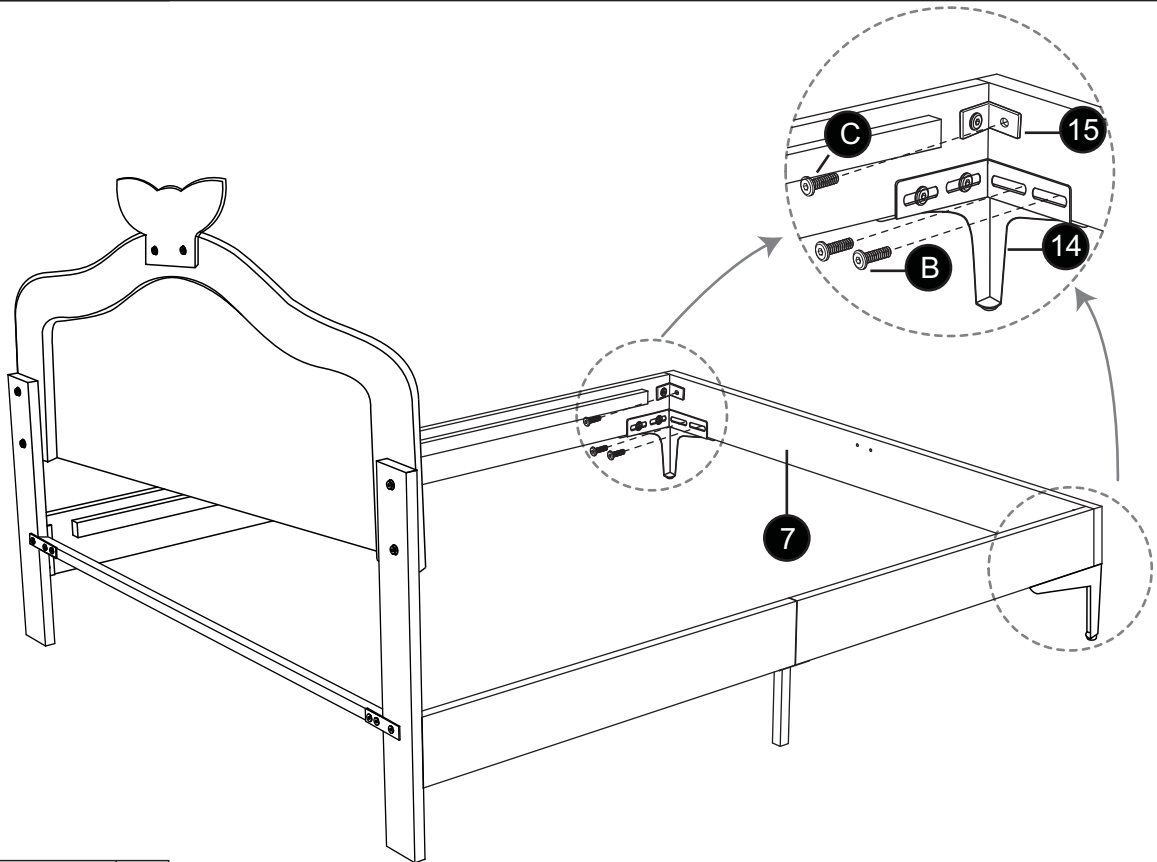

STPE 7

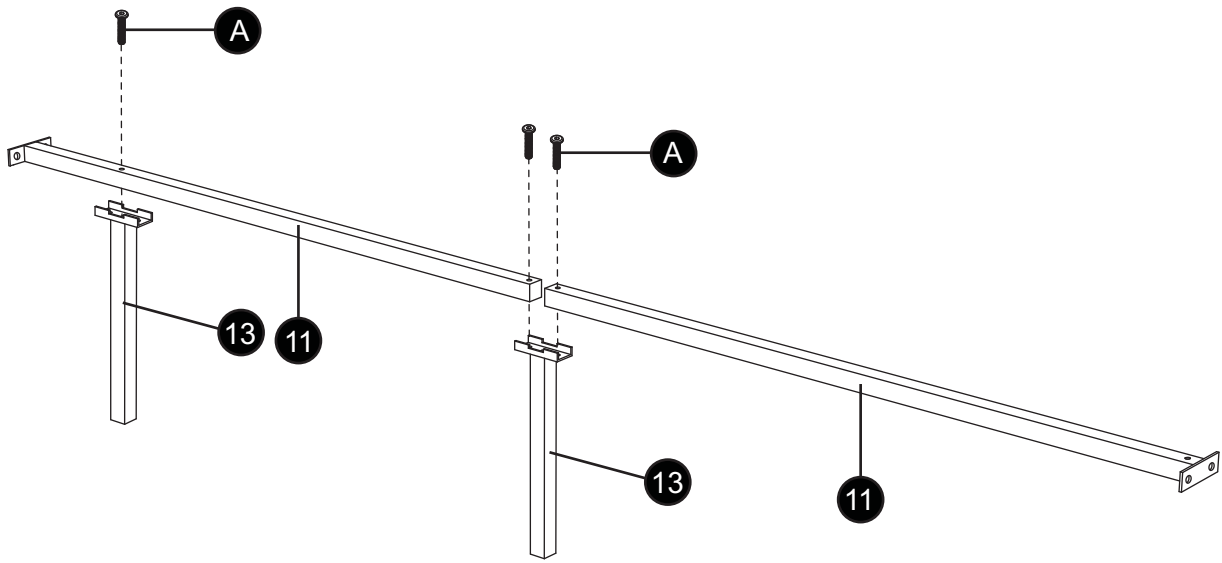

B		M8*25mm	4
C		M8*20mm	2

STPE 8



13		2
A	 M8*40mm	3

STPE 9

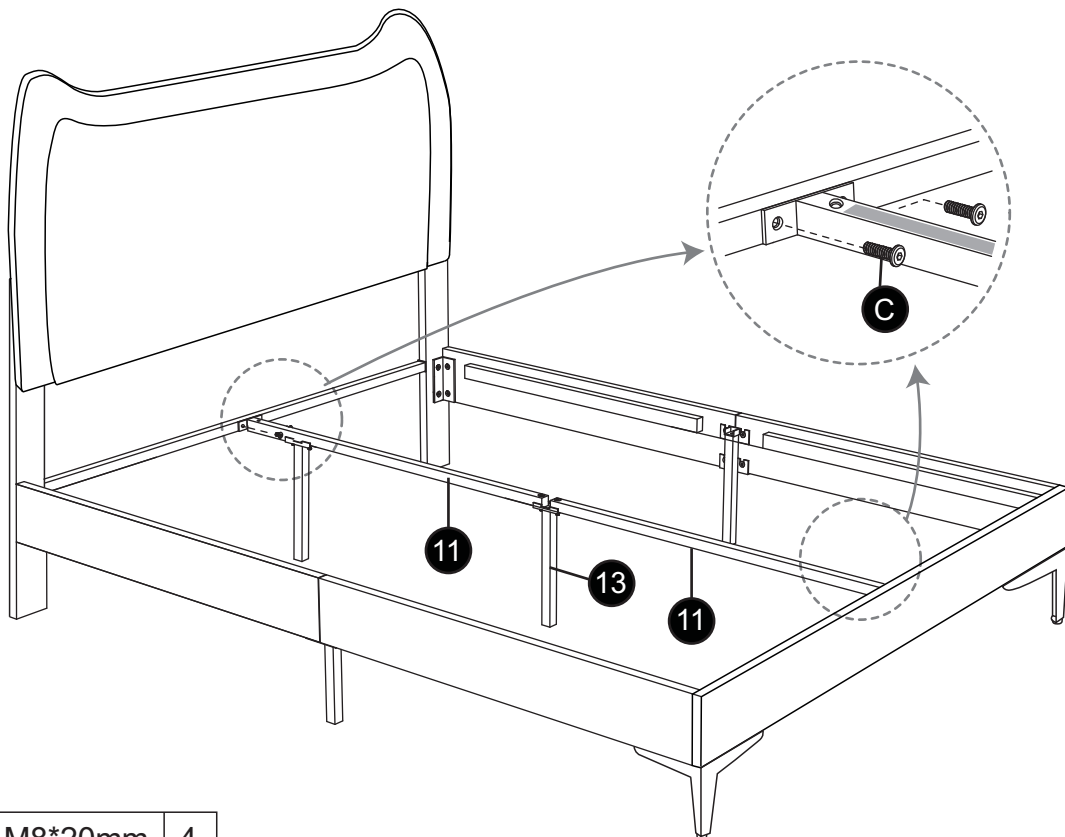

C	 M8*20mm	4
---	---	---

STPE 10

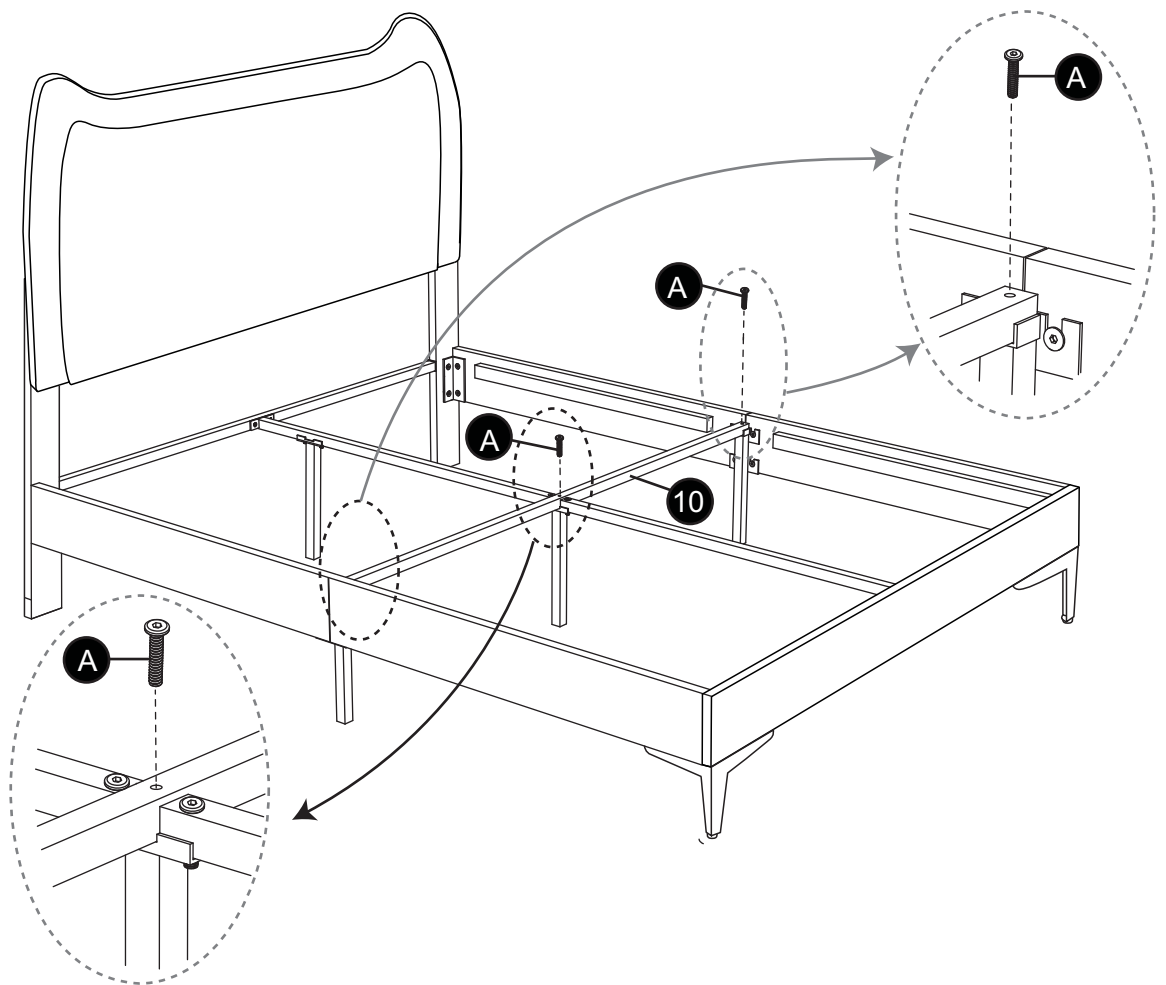

A  M8*40mm 3

STPE 11

