

Montageanleitung

Service-Hotline
01805-678101
0,14€ pro Minute
++49 für Österreich
Auslandstarif pro Minute
service@jaka-bkl.de
voor Nederland en België
00800-40119350
benelux@jaka-bkl.de

H661-3D
VH661-3
H661-8

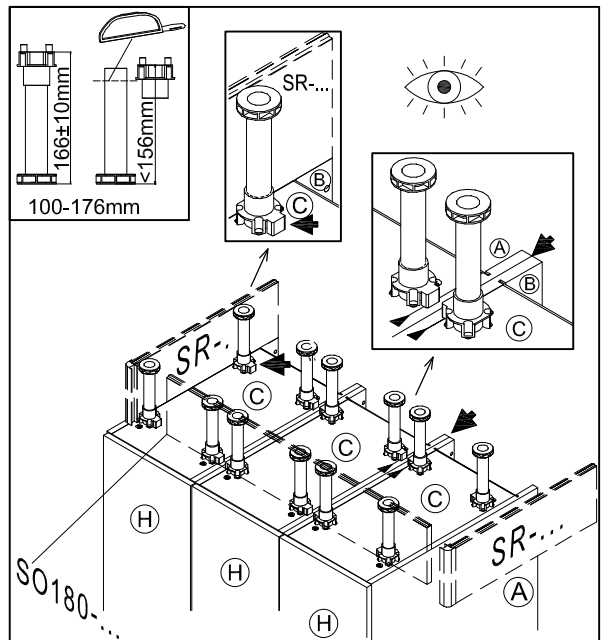
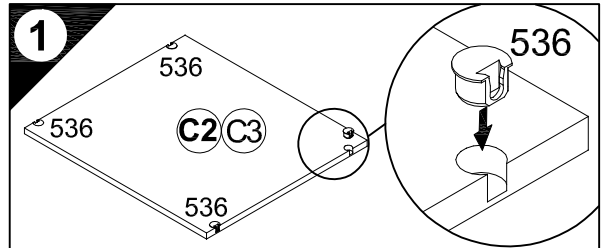
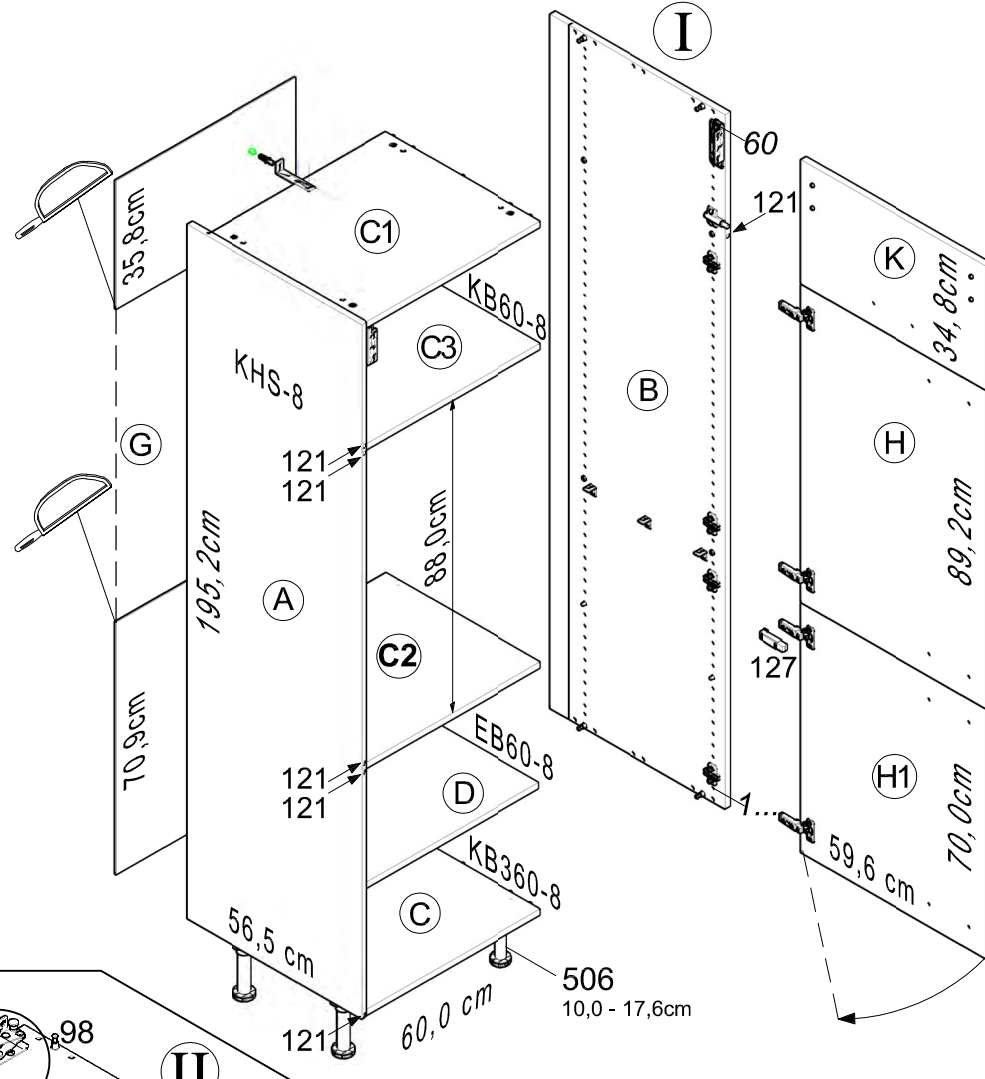
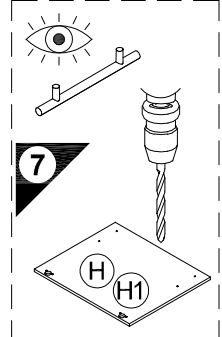
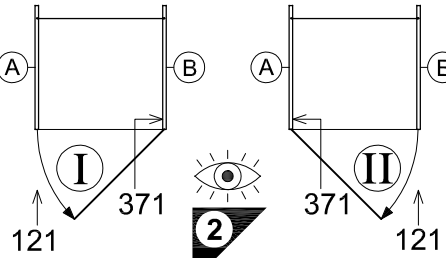
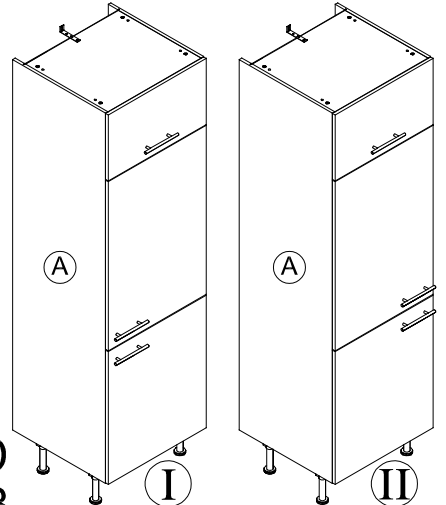

- 1 → 2 → 3 ...
- 8x Nr.536
- 8x Nr.98
- 4x Nr.371
- 4x 948027 Nr.502
- 3x Nr.121
- 8x 6,3x11,5 Nr.535
- 1x Nr.130 Nr.129 H661-3D
- 6x Nr.315
- 6x 3,5x15 Nr.181
- 1x Nr.375
- 4x 6,3x13 Nr.274
- 8x Nr.76
- 20x Ø8x30 Nr.80
- 2x Nr.506
- 4x Ø4x15 Nr.336

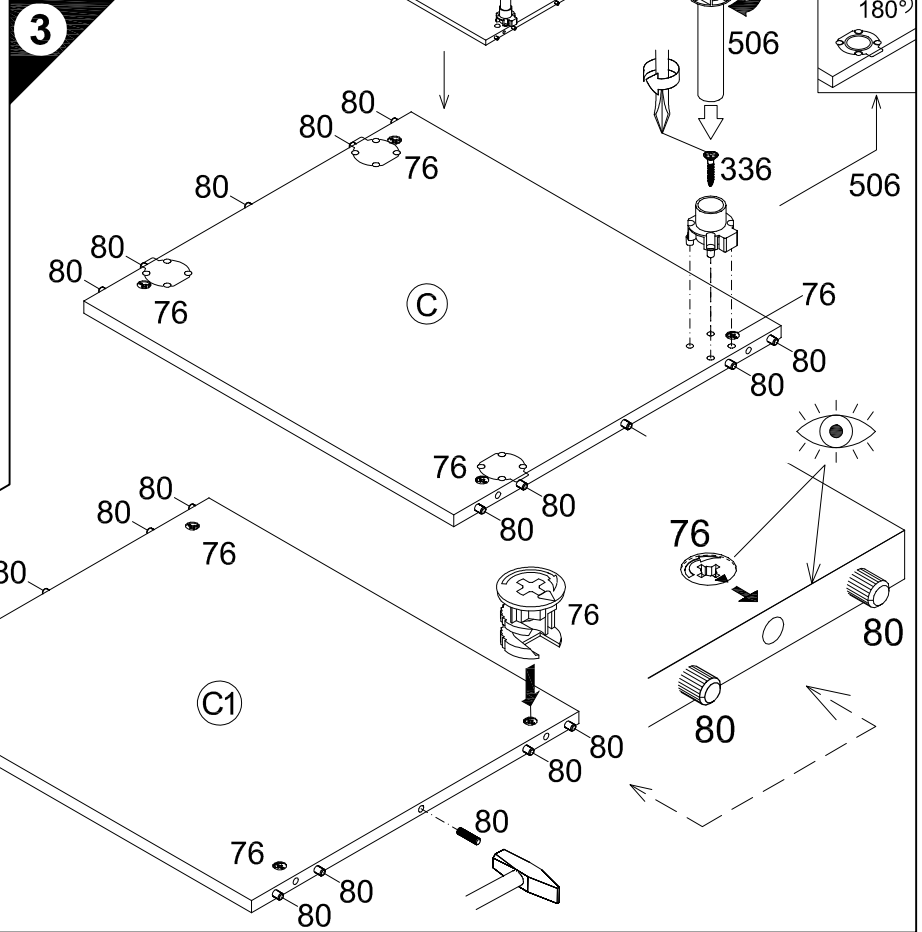
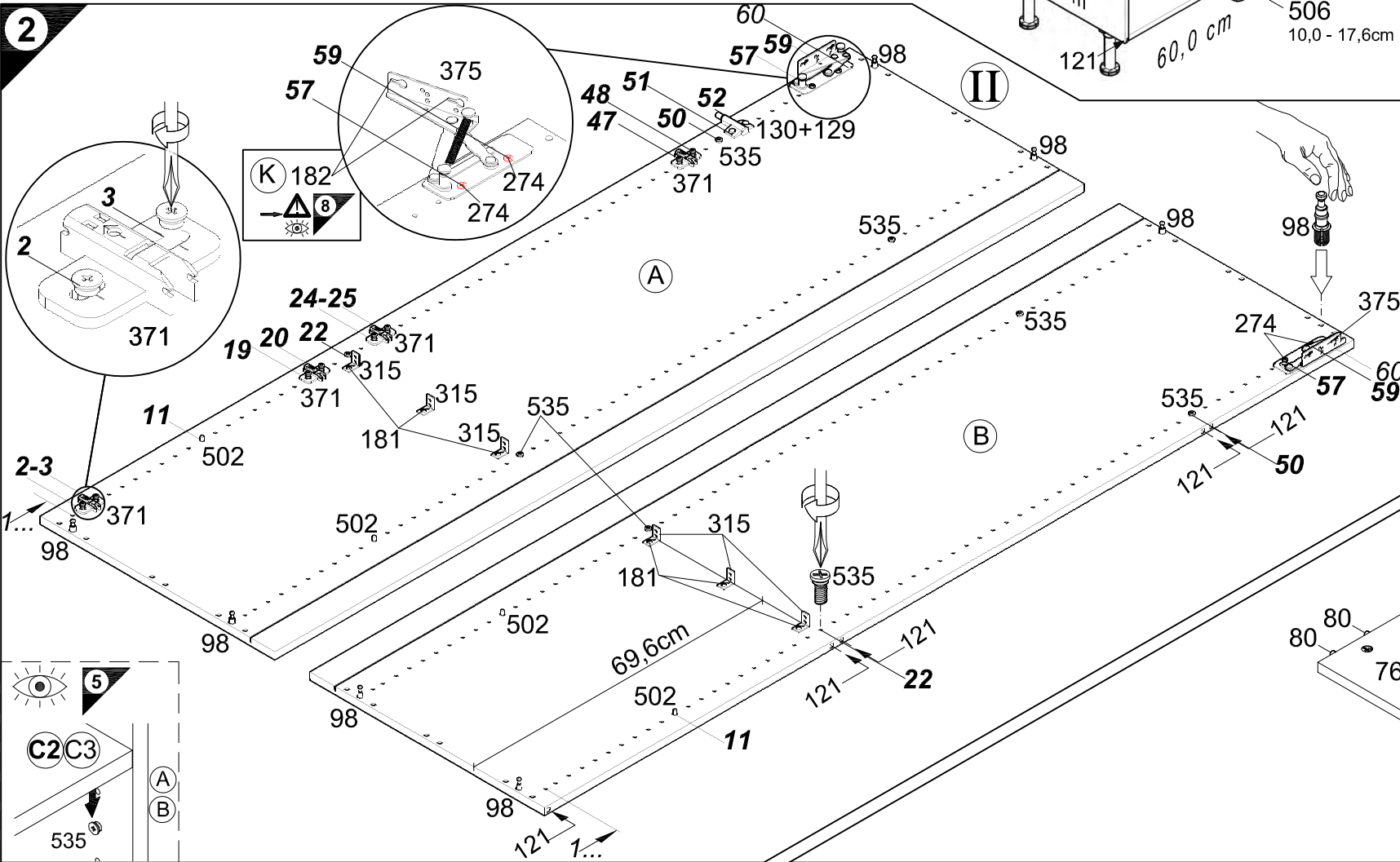

- 1 → 2 → 3 ...
- 6 20x Nr.204
- 8 4x 4x15 Nr.182
- 9 4x Nr.370
- 11 1x 419153 H661-3D VH661-3 Nr.127
- 12 2x 4,5x30 Nr.417 2x Nr.111
- 13 1x Ø8x40 Nr.70 1x 4,5x45 Nr.175
- 1x Nr.214 2x 4,5x15 Nr.191
- 14 1x Nr.505

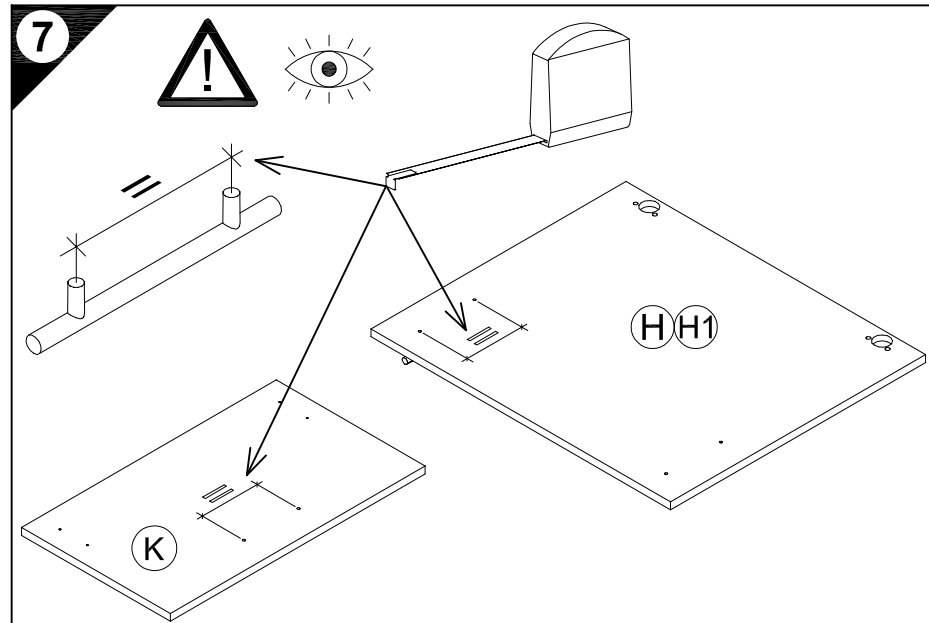
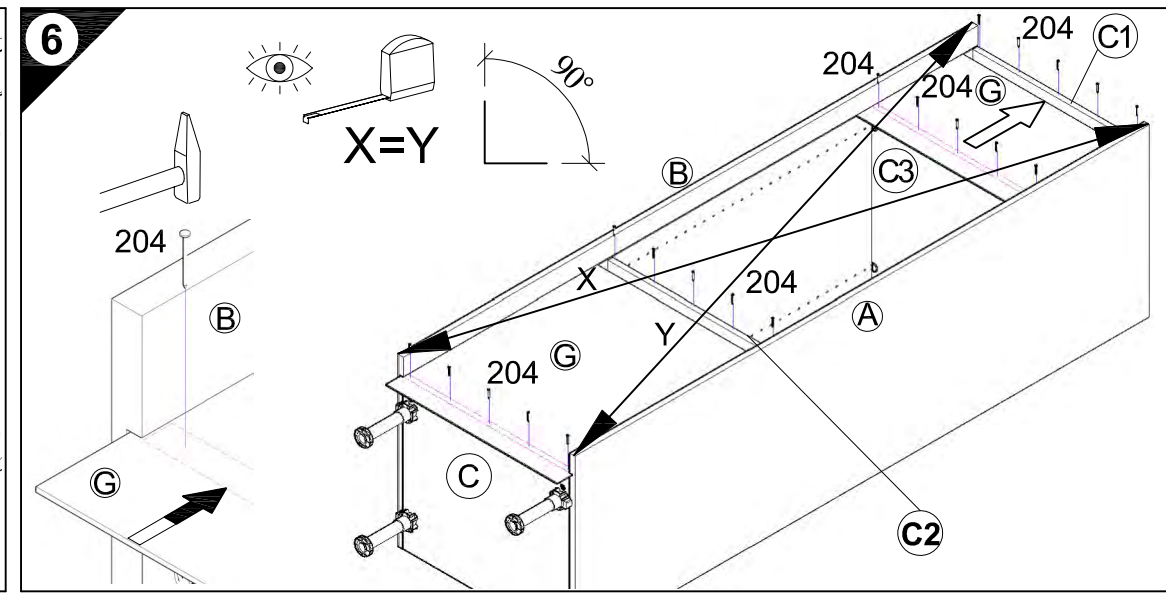
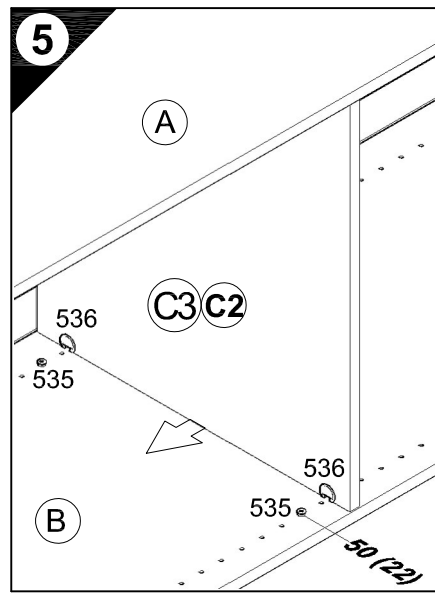
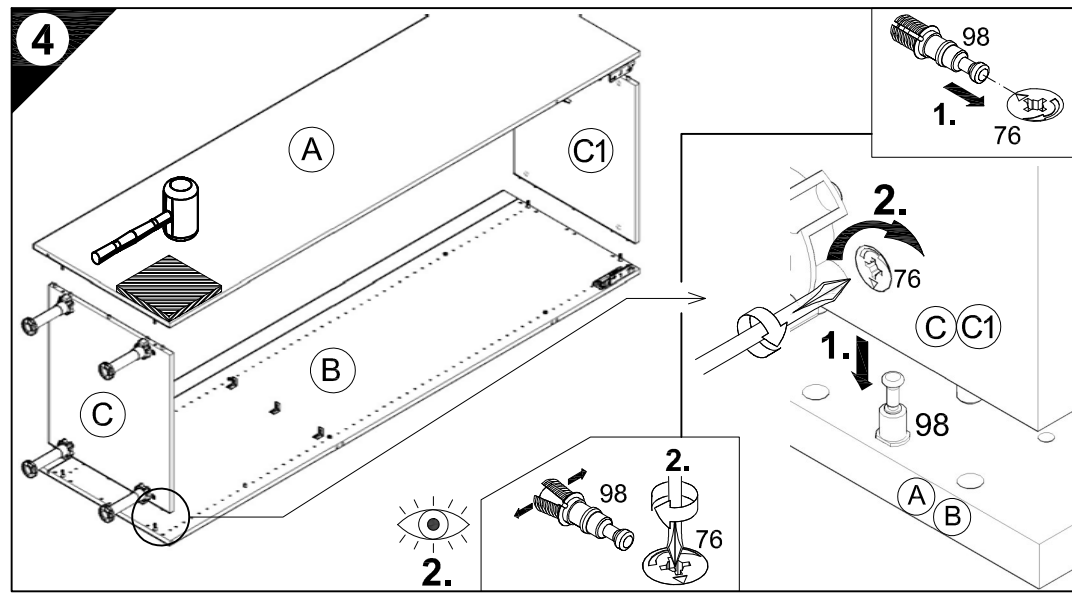

D Holzunterlage verwenden!
Front andrücken, scharfen Bohrer verwenden und mit wenig Druck durchbohren!

GB Use a wooden base!
Press front down, use sharp drill bit and, by applying slight pressure, drill a hole

F Utiliser un support en bois !
Appuyer sur la façade, utiliser un foret bien affûté et percer en appliquant une faible pression !

NL Houten onderlegger gebruiken!
Druk het front aan, gebruik een scherpe boor en oefen bij het boren weinig druk uit!

E ¡Utilizar una base de madera!
¡Presionar el frente, utilizar una broca afilada y taladrar con poca presión!

I Utilizzare una base di legno! Appoggiare la facciata, utilizzare una punta di trapano affilata e trapanare esercitando solo una leggera pressione!

RUS Использовать деревянную подложку!
Прижать фасад, использовать острое сверло и просверлить с незначительным давлением!

PL Używać podkładkę z drewna!
Docisnąć front, użyć oстрego wiertła i przewiercić, używając małej siły nacisku!

H Alkalmazzon fa alátétet!
Nyomja le az előlapot, használjon éles fúrót, és kis nyomással fúrja át!

CZ Použijte dřevěný podklad!
Přitlačte čelo, použijte ostrý vrták a provrtejte pomocí malého tlaku!

SLO Uporabite leseno podlago!
Pritisnite ličnico ter z ostrim svedrom in z majhnim pritiskom izvrtajte luknjjo!

FIN Käytä puualustaa!
Paina etulevy paikoilleen, käytä terävää poranterää ja poraa reikä vain kevyesti painamalla!

S Använd ett träunderlag!
Tryck fronten mot underlaget, använd vass borrh och borra igenom med ett lätt tryck!

SK Použite drevený podklad!!
Pritlačte front, použite ostrý vrták a prevrtajte miernym tlakom!

RO suport de lemn! Împingeți frontul, utilizați un burghiu ascuțit și perforați exercitând doar o presiune redusă!

TR Ahşap taban kullanın!
Önden bastırın, keskin matkap ucu kullanın ve az basınç uygulayarak delin!

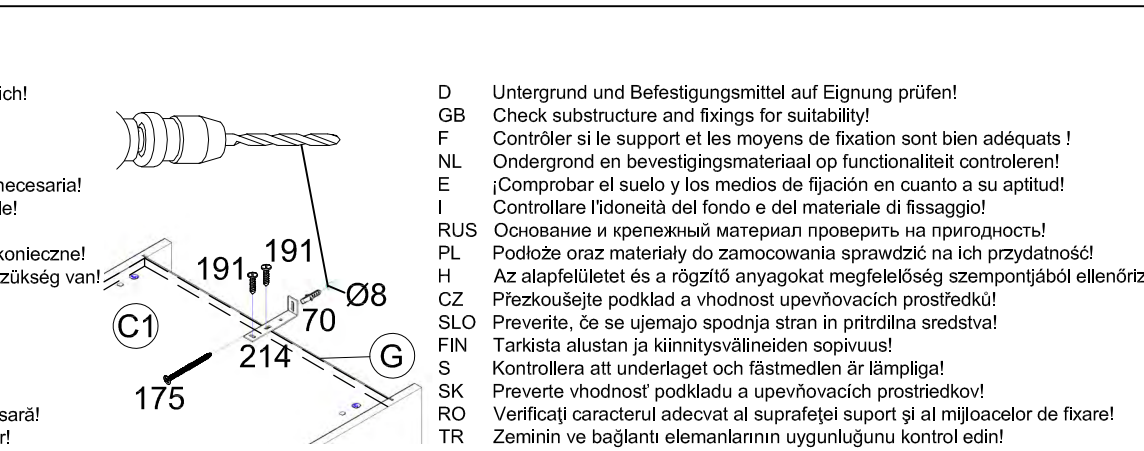
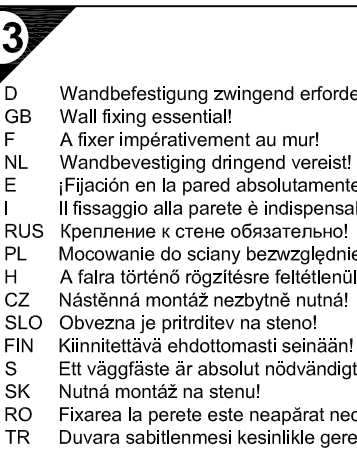
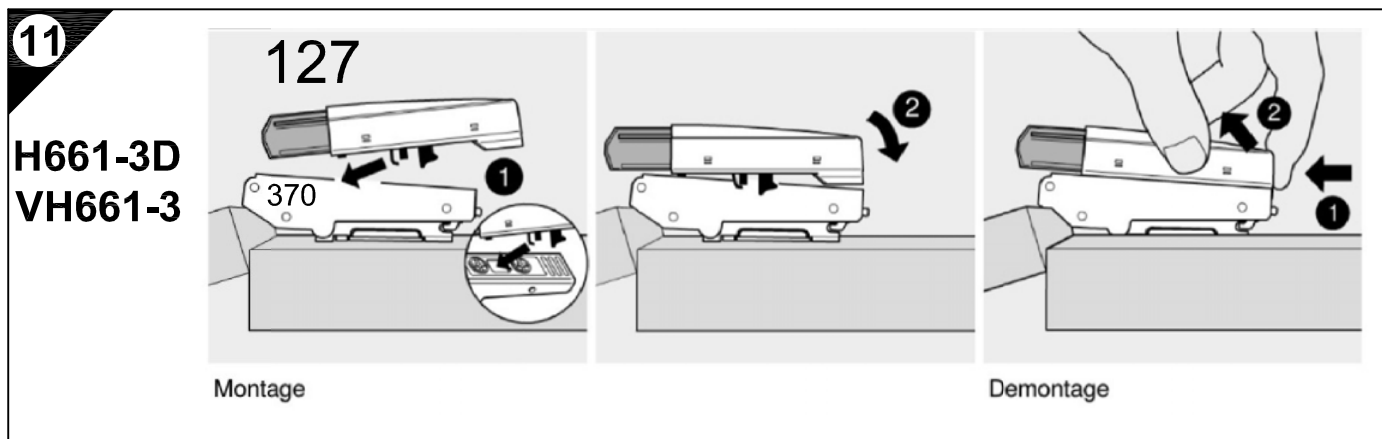
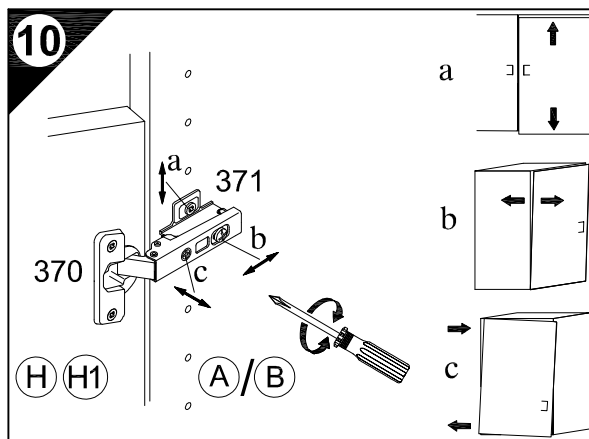
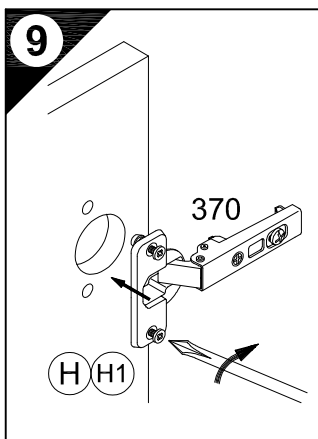
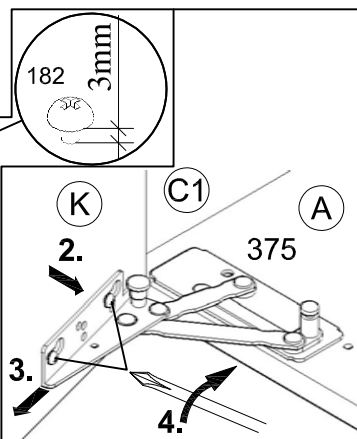
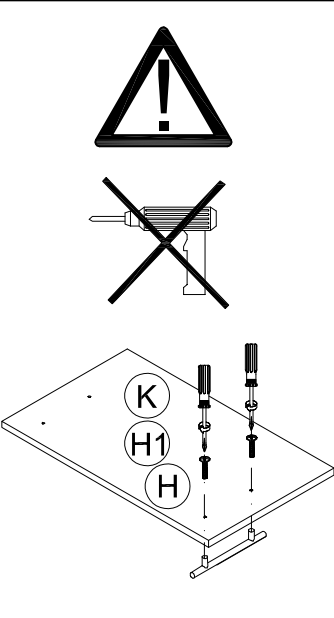

D Wandbefestigung zwingend erforderlich!
GB Wall fixing essential!
F A fixer impérativement au mur!
NL Wandbevestiging dringend vereist!
E ¡Fijación en la pared absolutamente necesaria!
I Il fissaggio alla parete è indispensabile!
RUS Крепление к стене обязательно!
PL Mocowanie do ściany bezwzględnie konieczne!
H A falra történő rögzítésre feltétlenül szükség van!
CZ Nástěnná montáž nezbytně nutná!
SLO Obvezna je pritrditev na steno!
FIN Kiinnitettävä ehdottomasti seinään!
S Ett väggfäste är absolut nödvändigt!
SK Nutná montáž na stenu!
RO Fixarea la perete este neapărat necesară!
TR Duvara sabitlenmesi kesinlikle gerekir!

D Untergrund und Befestigungsmittel auf Eignung prüfen!
GB Check substructure and fixings for suitability!
F Contrôler si le support et les moyens de fixation sont bien adéquats !
NL Ondergrond en bevestigingsmateriaal op functionaliteit controleren!
E ¡Comprobar el suelo y los medios de fijación en cuanto a su aptitud!
I Controllare l'idoneità del fondo e del materiale di fissaggio!
RUS Основание и крепежный материал проверить на пригодность!
PL Podłoże oraz materiały do zamocowania sprawdzić na ich przydatność!
H Az alapfelületet és a rögzítő anyagokat megfelelőség szempontjából ellenőrizni kell!
CZ Přezkoušejte podklad a vhodnost upevňovacích prostředků!
SLO Preverite, če se ujemajo spodnja stran in pritrdilna sredstva!
FIN Tarkista alustan ja kiinnitysvälineiden sopivuus!
S Kontrollera att underlaget och fästmedlen är lämpliga!
SK Preverte vhodnosť podkladu a upevňovacích prostriedkov!
RO Verificați caracterul adecvat al suprafeței suport și al mijloacelor de fixare!
TR Zeminin ve bağlanıtı elemanlarının uygunluğunu kontrol edin!

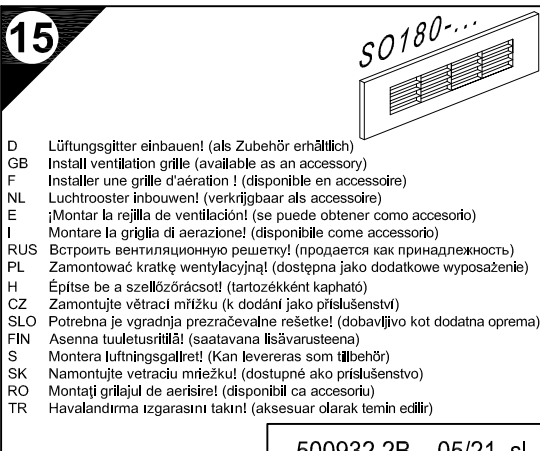
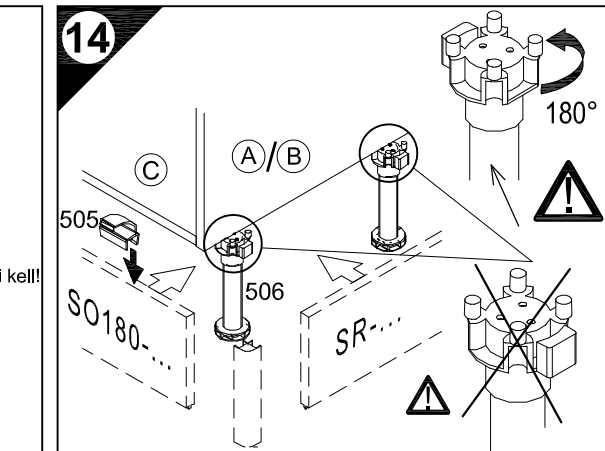

D Lüftungsgitter einbauen! (als Zubehör erhältlich)
GB Install ventilation grille (available as an accessory)
F Installer une grille d'aération ! (disponible en accessoire)
NL Luchtrooster inbouwen! (verkrijgbaar als accessoire)
E ¡Montar la rejilla de ventilación! (se puede obtener como accesorio)
I Montare la griglia di aerazione! (disponibile come accessorio)
RUS Встроить вентиляционную решетку! (продается как принадлежность)
PL Zamontować kratkę wentylacyjną! (dostępna jako dodatkowe wyposażenie)
H Építse be a szellőzőrácsot! (tartozékként kapható)
SLO Zamontujte vetrací mřížku (k dodání jako příslušenství)
CZ Potřebna je vgradnja prezračevalne rešetke! (dobavljivo kot dodatna oprema)
FIN Asenna tuuletusräjä! (saatavana lisävarusteena)
S Montera luftningsgaller! (Kan levereras som tillbehör)
SK Namontujte vetraciu mriežku! (dostupné ako príslušenstvo)
RO Montați grilajul de aerisire! (disponibil ca accesoriu)
TR Havalandırma ızgarasını takın! (aksesuar olarak temin edilir)

BLU-MT2

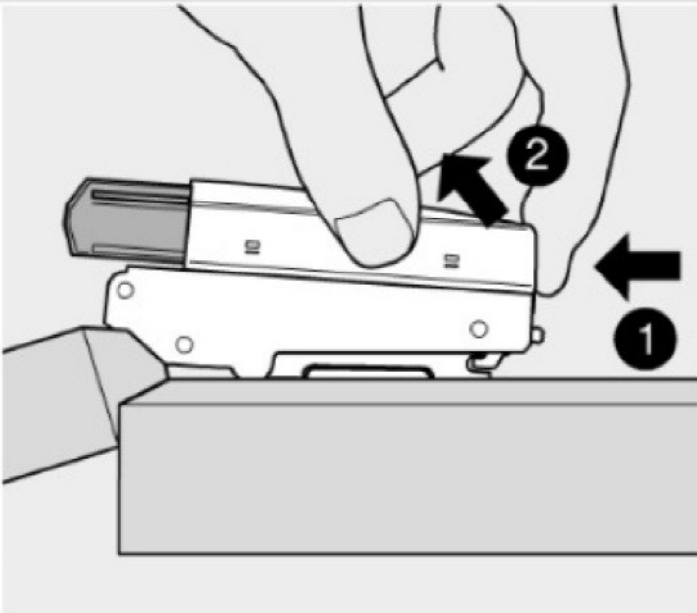
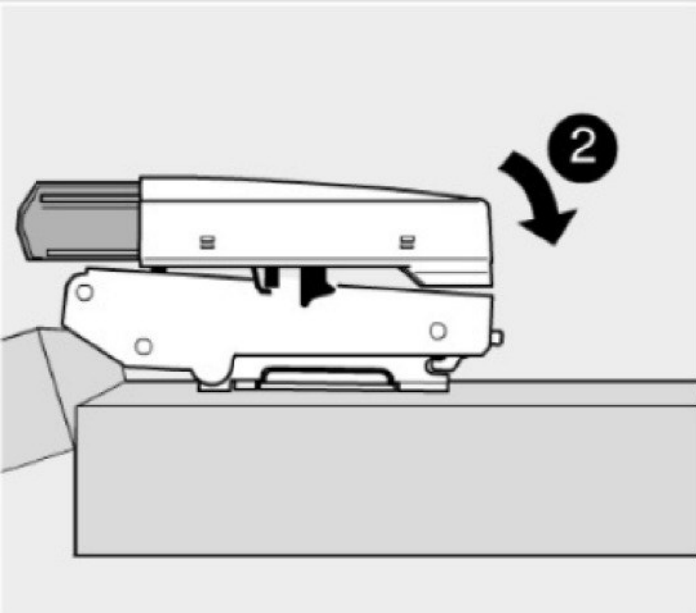
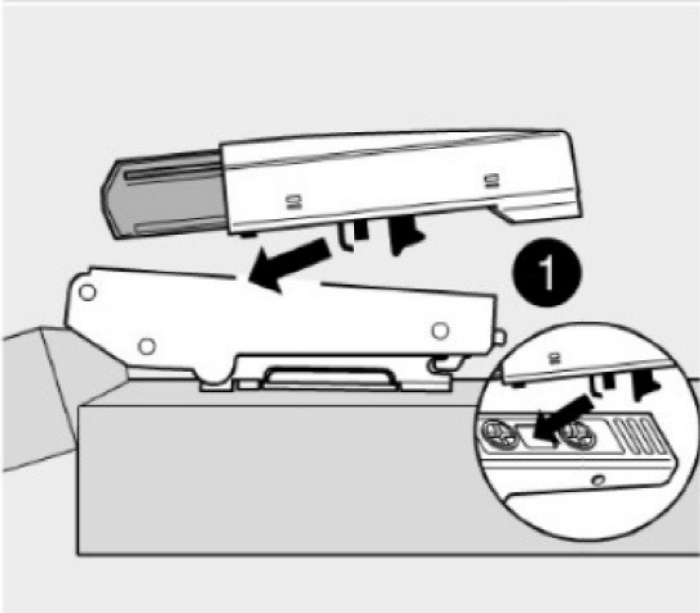

Montage

Demontage

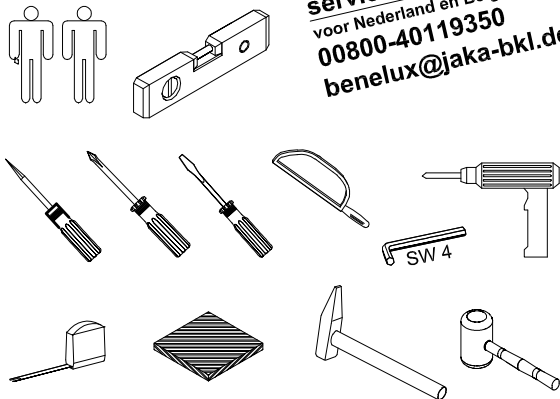

Montageanleitung

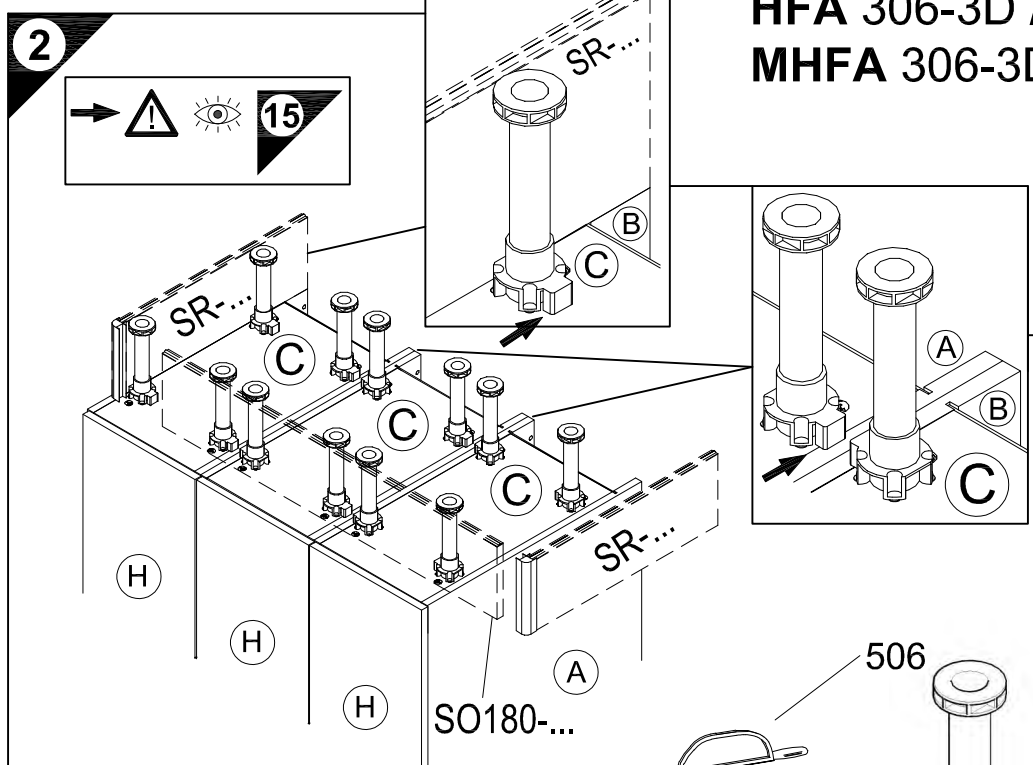
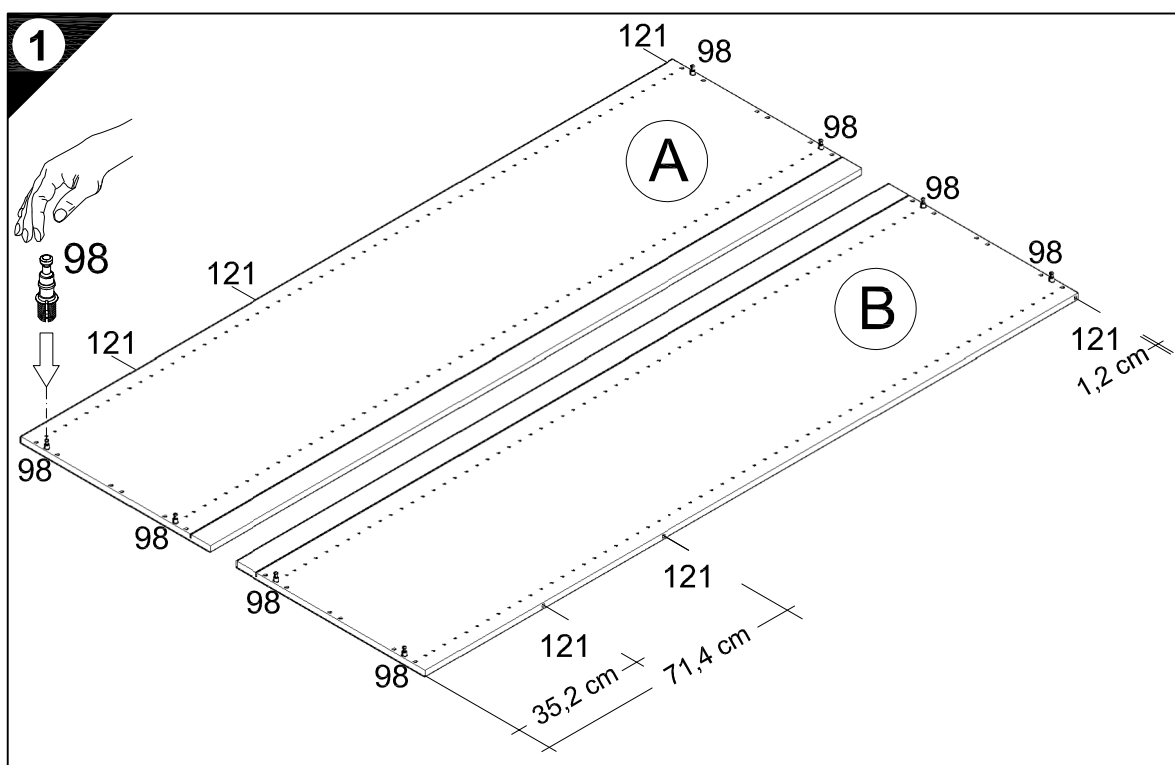
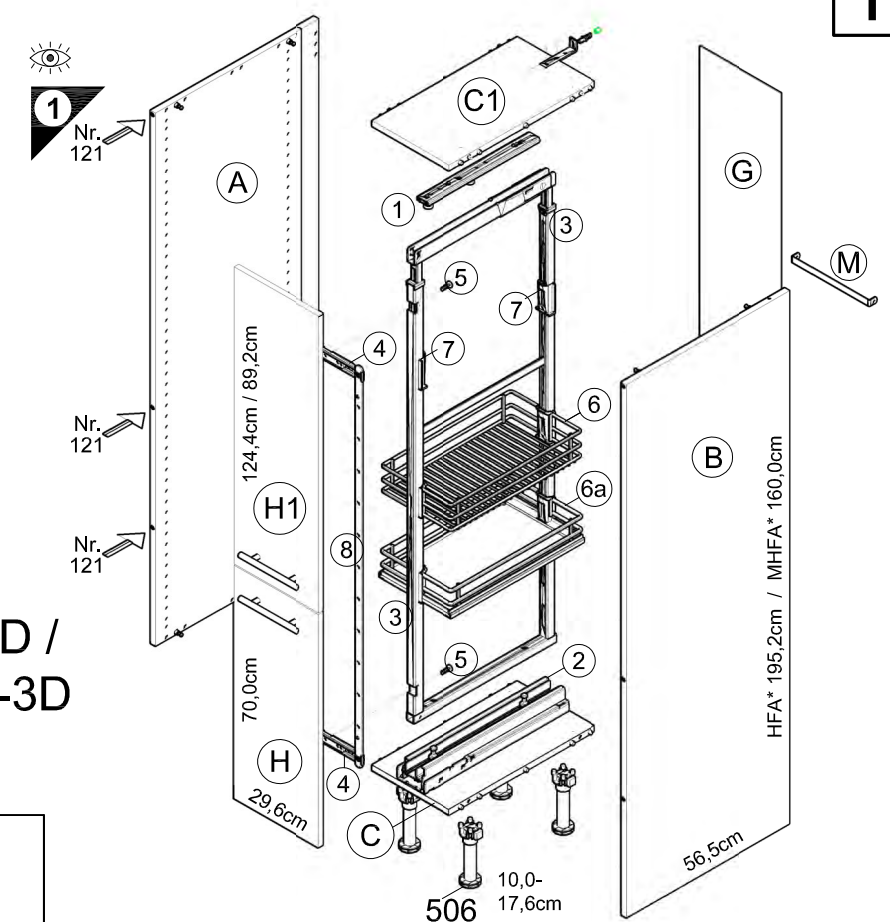
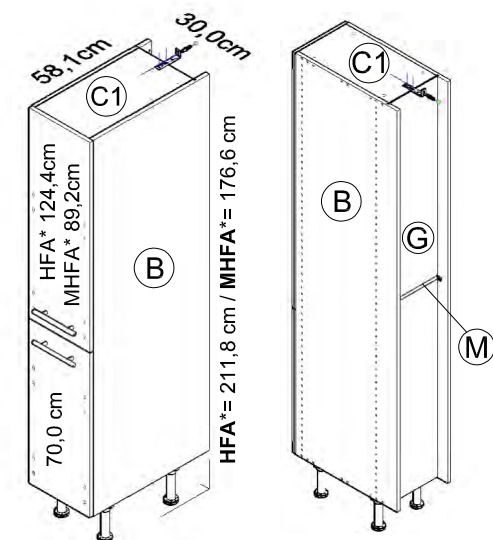
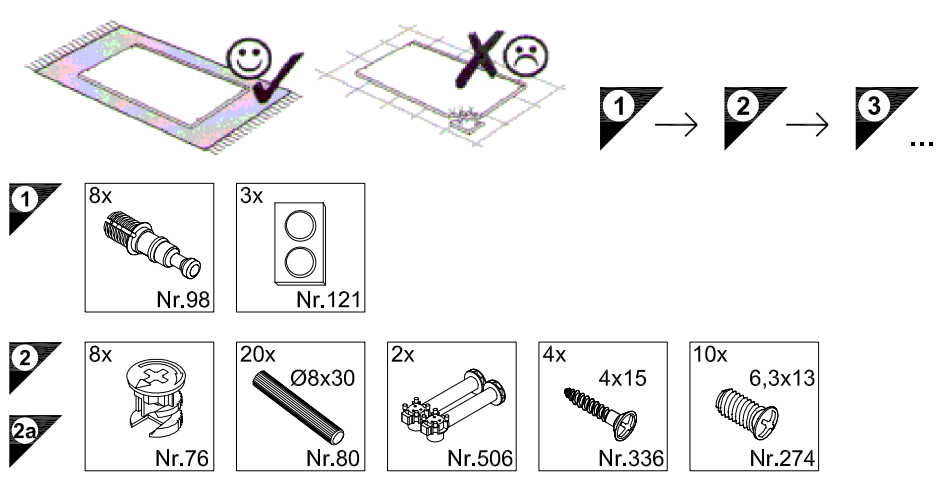

HFA 306-3D / MHFA 306-3D

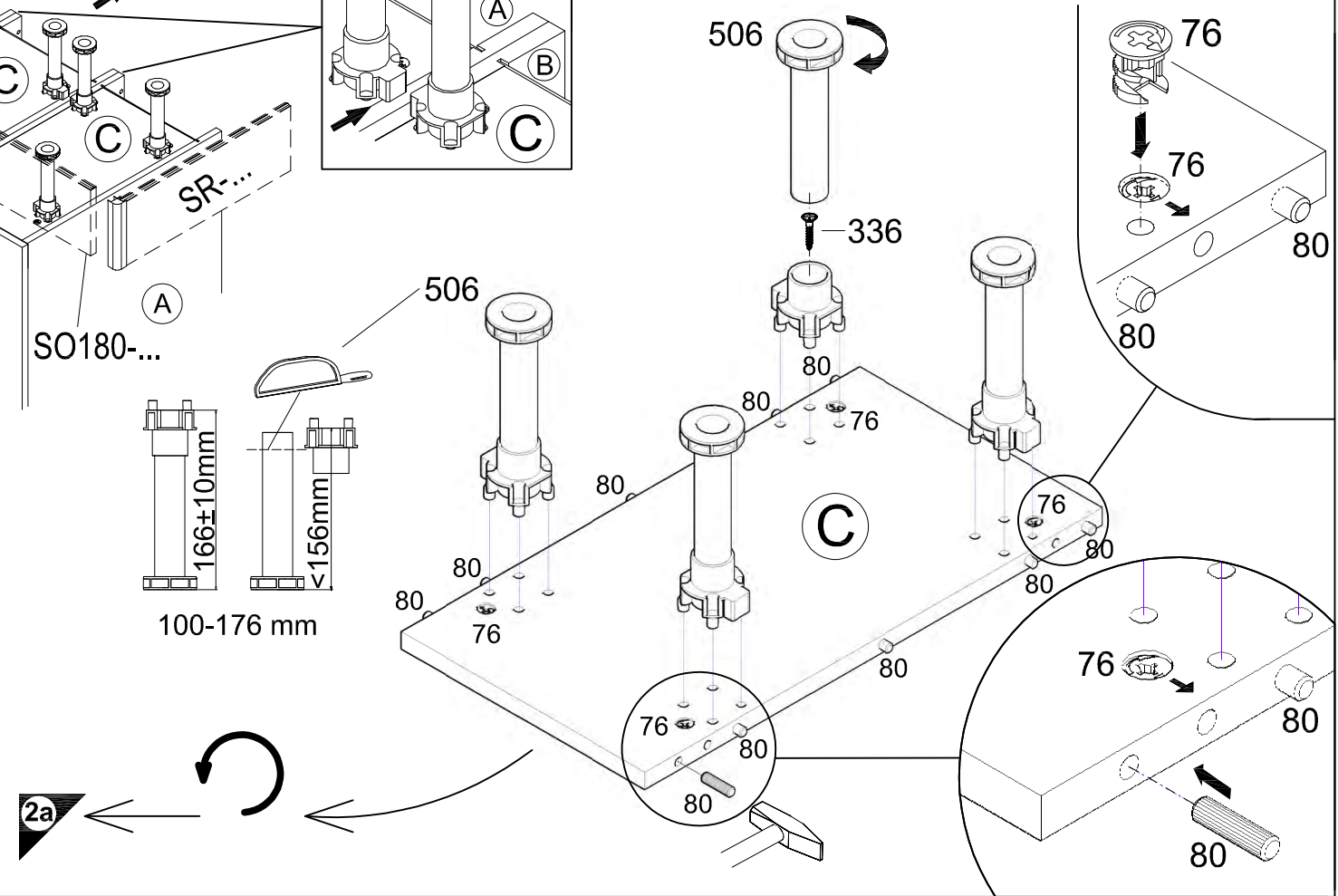
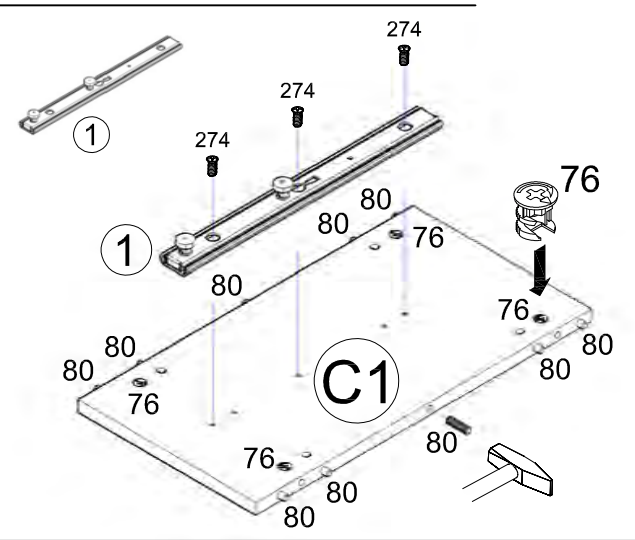
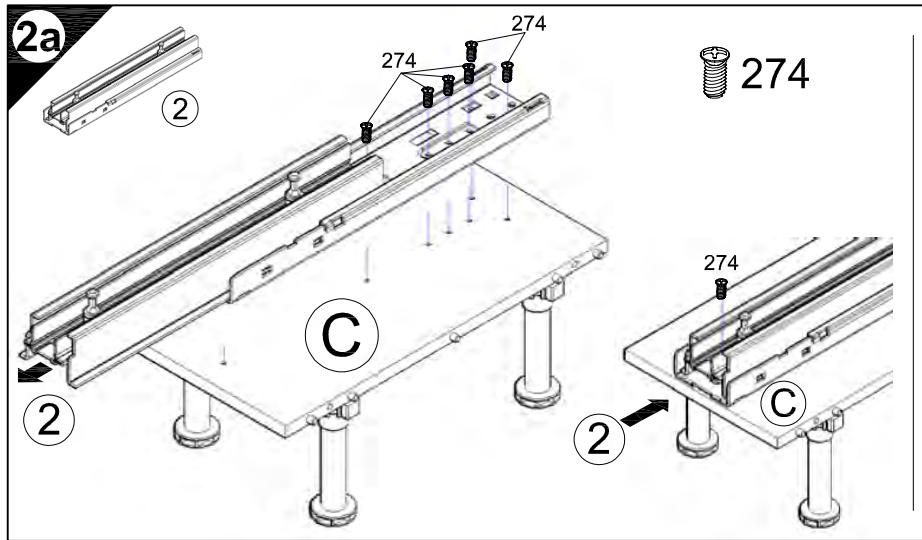

Ersatzteile/Spare parts/pièces de rechange/Reserveonderdelen/Piezas de recambio/Ricambi/Запасные части/Części zamienne/pótkatkrészek/Náhradní části/Nadomestni deli/varaosat/reservdelar/náhradné diely/Utilizați piese de schimb/Yedek parçalar

30cm HFA306-3D	(A) E941011	(B) E941011	(C) E951222	(C1) E954222	(G) E970023	(H) E940596	(H1) E940607	(M) E948045	①②③④⑤⑦⑧ E448060	⑥ E448062	⑥a E448052
30cm MHFA306-3D	(A) E941005	(B) E941005	(C) E951222	(C1) E954222	(G) E970036	(H) E940596	(H1) E940603	(M) E948045	①②③④⑤⑦⑧ E448050	⑥ E448053	⑥a E448052

1 → 2 → 3 ...

- 4 20x
Nr.204
- 5 2x 3,5x15
Nr.181
- 6 2x 4,5x30
Nr.417
- 2x
Nr.111
- 7 1x
Nr.214
- 2x 4,5x15
Nr.191
- 1x Ø8
Nr.70
- 1x 4,5x45
Nr.175

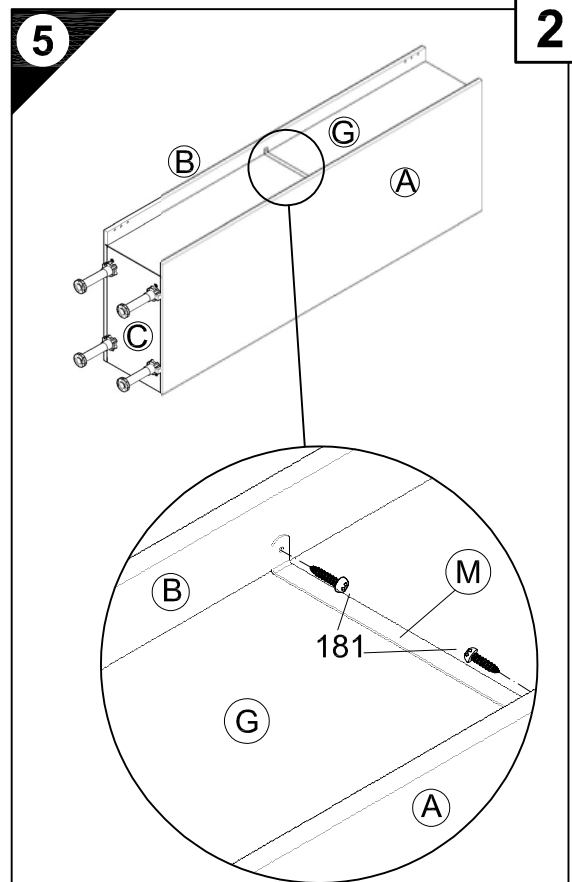
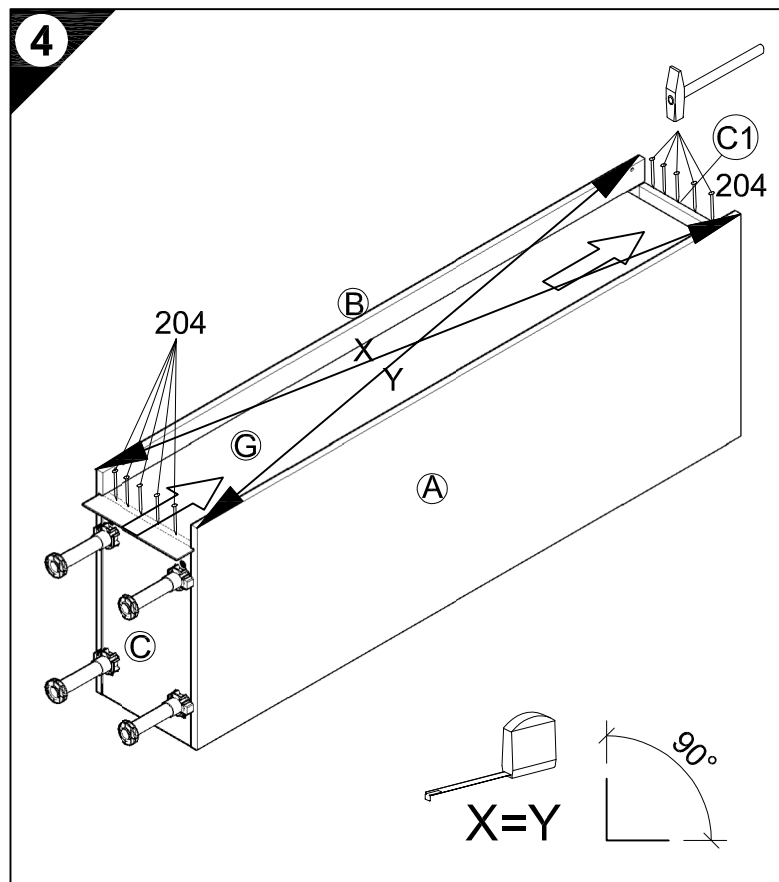
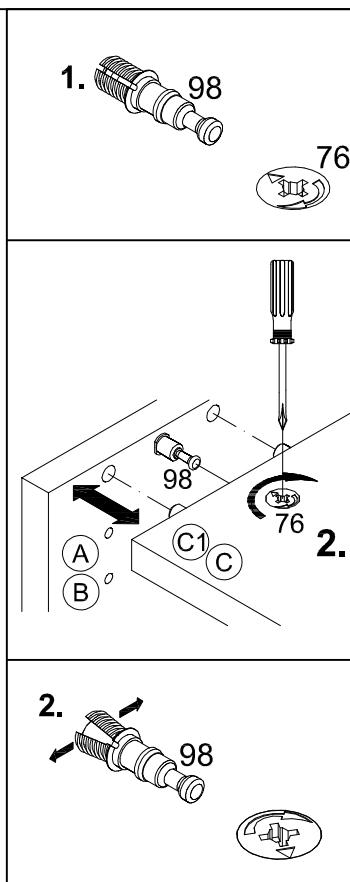
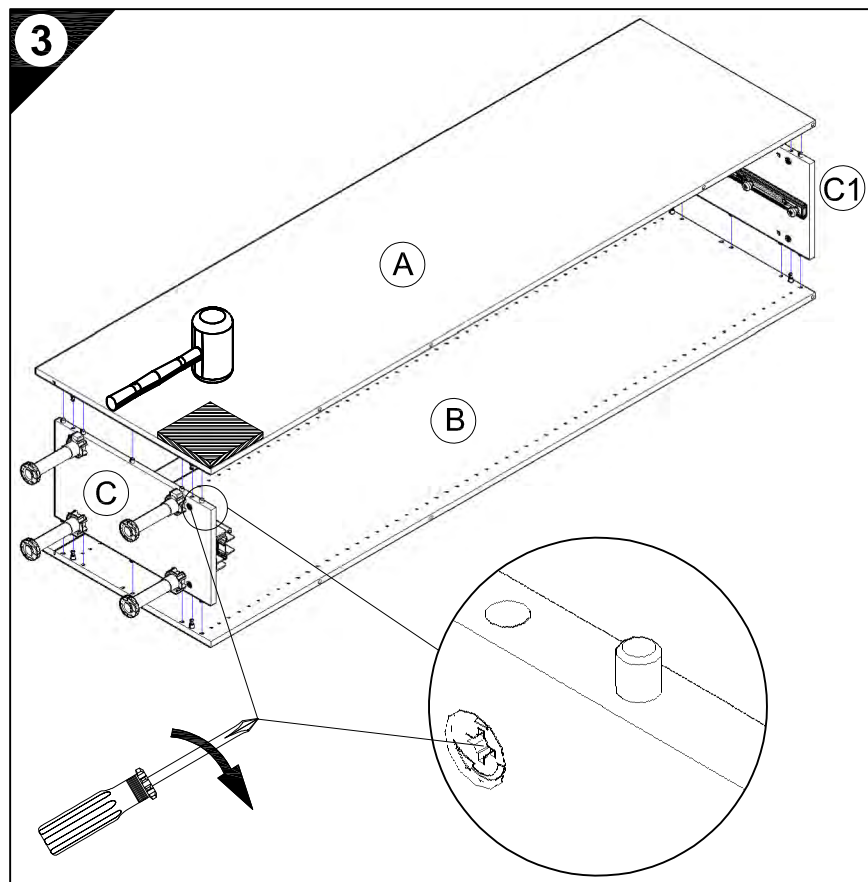

- 6
- D Wandbefestigung zwingend erforderlich!
GB Wall fixing essential!
F A fixer impérativement au mur!
NL Wandbevestiging dringend vereist!
E ¡Fijación en la pared absolutamente necesaria!
I Il fissaggio alla parete è indispensabile!
RUS Крепление к стене обязательно!
PL Mocowanie do sciany bezwzględnie konieczne!
H A falra törtéző rögzítésre feltétlenül szükség van!
CZ Nástěnná montáž nezbytně nutná!
SLO Obvezna je pritrditev na steno!
FIN Kiinnitettävä ehdottomasti seinään!
S Ett väggfäste är absolut nödvändigt!
SK Nutná montáž na stenu!
RO Fixarea la perete este neapărat necesară!
TR Duvara sabitlenmesi kesinlikle gerekir!

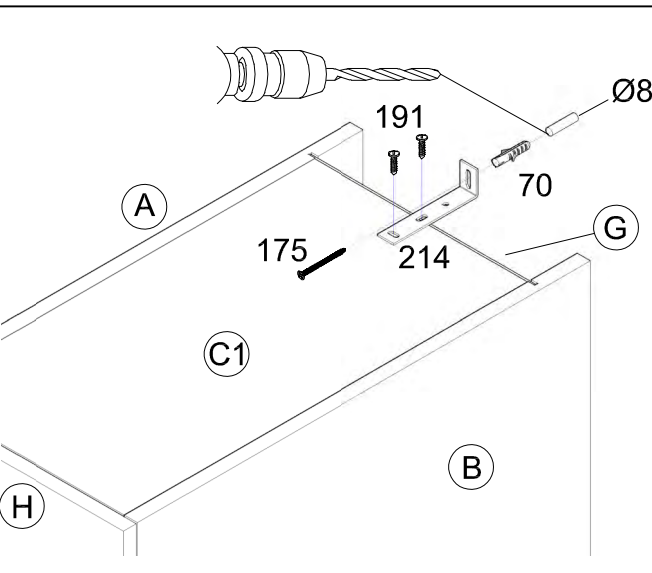

- 7
- D Untergrund und Befestigungsmittel auf Eignung prüfen!
GB Check substructure and fixings for suitability!
F Contrôler si le support et les moyens de fixation sont bien adéquats !
NL Ondergrond en bevestigingsmateriaal op functionaliteit controleren!
E ¡Comprobar el suelo y los medios de fijación en cuanto a su aptitud!
I Controllare l'idoneità del fondo e del materiale di fissaggio!
RUS Основание и крепежный материал проверить на пригодность!
PL Podłoże oraz materiały do zamocowania sprawdzić na ich przydatność!
H Az alapelületet és a rögzítő anyagokat megfelelőség szempontjából ellenőrizni kell!
CZ Přezkoušejte podklad a vhodnost upevňovacích prostředků!
SLO Preverite, če se ujemajo spodnja stran in pritrdilna sredstva!
FIN Tarkista alustan ja kiinnitysvälineiden sopivuus!
S Kontrollera att underlaget och fästmedlen är lämpliga!
SK Preverte vhodnosť podkladu a upevňovacích prostriedkov!
RO Verificați caracterul adecvat al suprafeței suport și al mijloacelor de fixare!
TR Zemin ve bağlantı elemanlarının uygunluğunu kontrol edin!

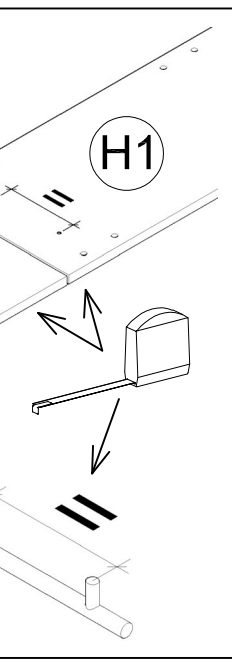
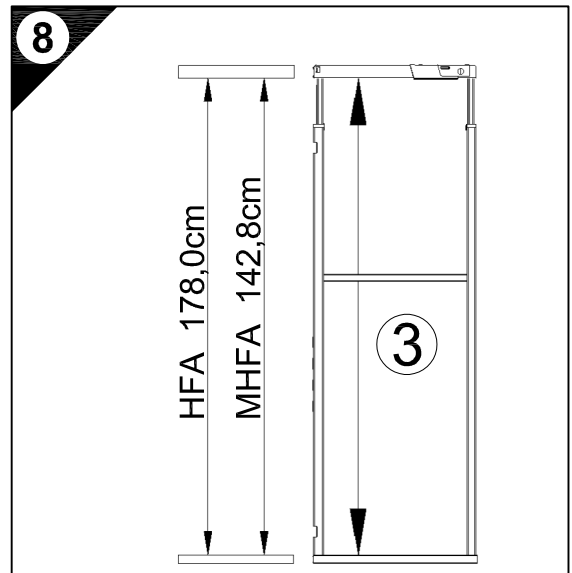

- 9
- D Holzunterlage verwenden!
Front andrücken, scharfen Bohrer verwenden und mit wenig Druck durchbohren!
GB Use a wooden base!
Press front down, use sharp drill bit and, by applying slight pressure, drill a hole
F Utiliser un support en bois !
Appuyer sur la façade, utiliser un foret bien affûté et percer en appliquant une faible pression !
NL Houten onderlegger gebruiken!
Druk het front aan, gebruik een scherpe boor en oefen bij het boren weinig druk uit!
E ¡Utilizar una base de madera!
¡Presionar el frente, utilizar una broca afilada y taladrar con poca presión!
I Utilizzare una base di legno! Appoggiare la facciata, utilizzare una punta di trapano affilata e trapanare esercitando solo una leggera pressione!
RUS Использовать деревянную подложку!
Прижать фасад, использовать острое сверло и просверлить с незначительным давлением!
PL Używać podkładkę z drewna!
Docisnąć front, użyć ostrego wiertła i przewiercić, używając małej siły nacisku!

- H Alkalmazzon fa alátétet!
Nyomja le az előlapot, használgjon éles fúrót, és kis nyomással fúrja át!
CZ Použijte dřevěný podklad!
Přitlačte čelo, použijte ostrý vrták a provrtějte pomocí malého tlaku!
SLO Uporabite leseno podlogo!
Pritisnite ličnico ter z ostrim svedom in z majhnim pritiskom izvrtajte luknjo!
FIN Käytä puualustaa!
Paina etulevy paikoilleen, käytä terävää poranterää ja poraa reikä vain kevyesti painamalla!
S Använd ett träunderlag!
Tryck fronten mot underlaget, använd vass borr och borra igenom med ett lätt tryck!
SK Použite drevený podklad!!
Přitlačte front, použijte ostrý vrták a převrtajte miernym tlakom!
RO suport de lemn! Împingeți frontul, utilizați un burghiu ascuțit și perforați exercitând doar o presiune redusă!
TR Ahşap taban kullanın!
Önden bastırın, keskin matkap ucu kullanın ve az basınç uygulayarak delin!

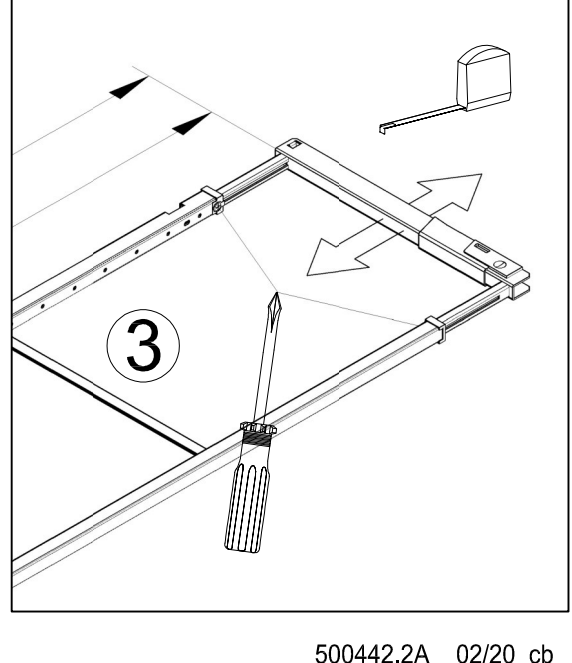
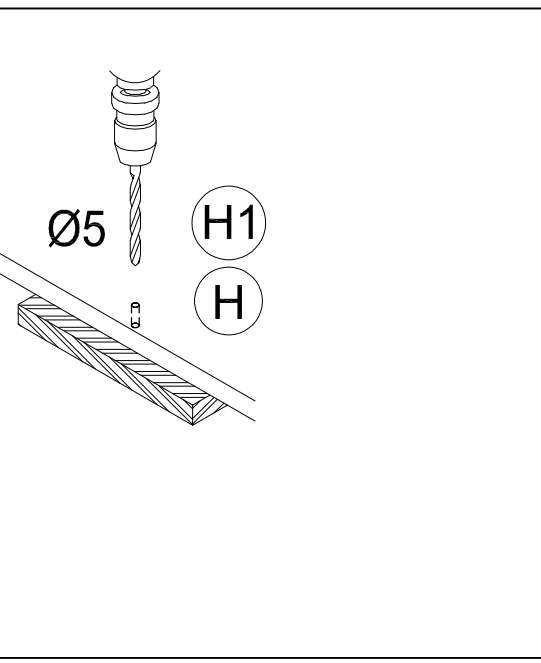

1 → 2 → 3 ...

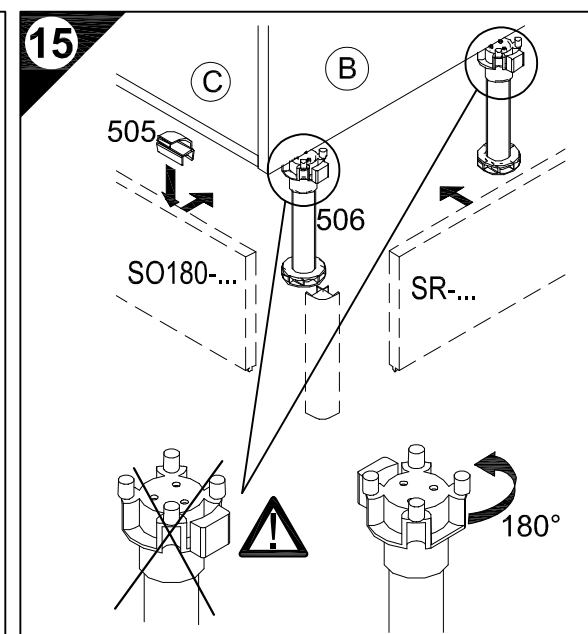
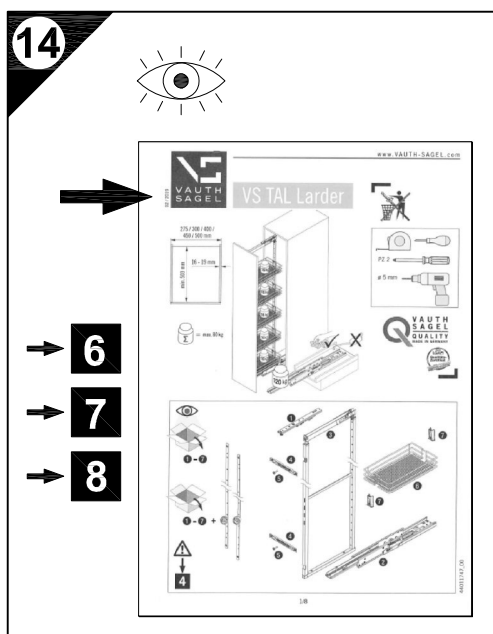
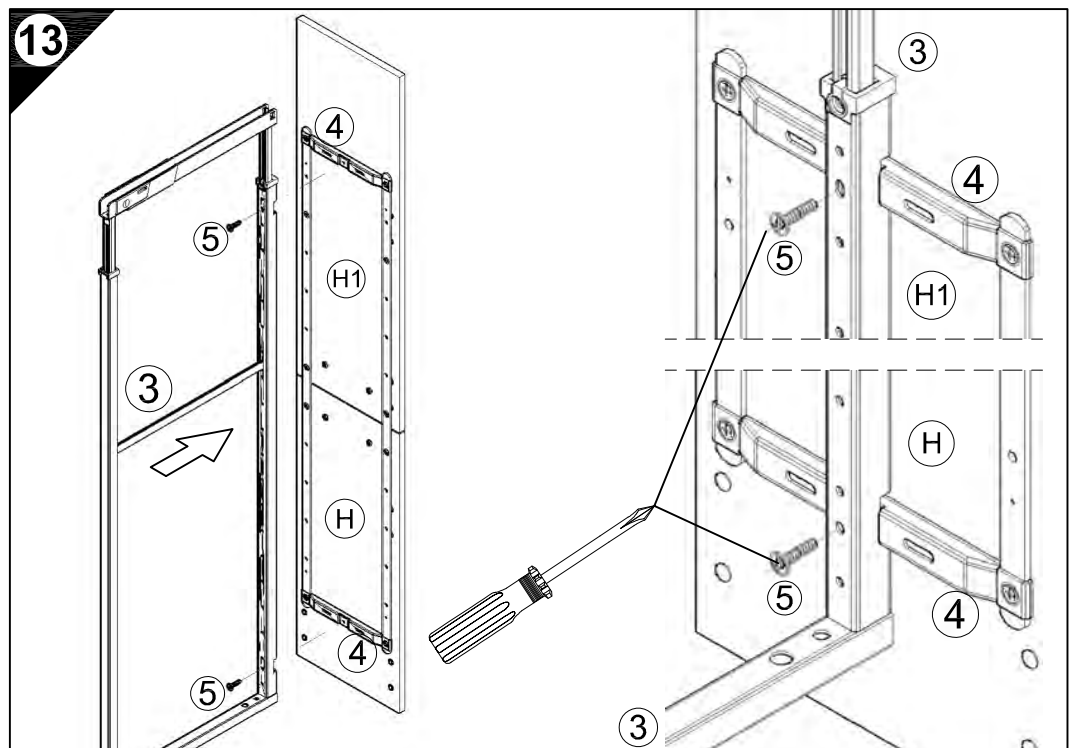
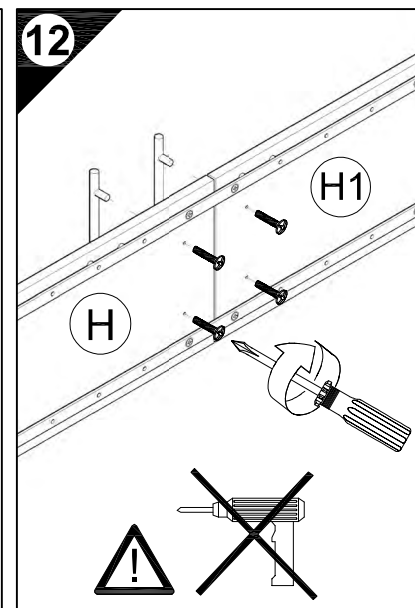
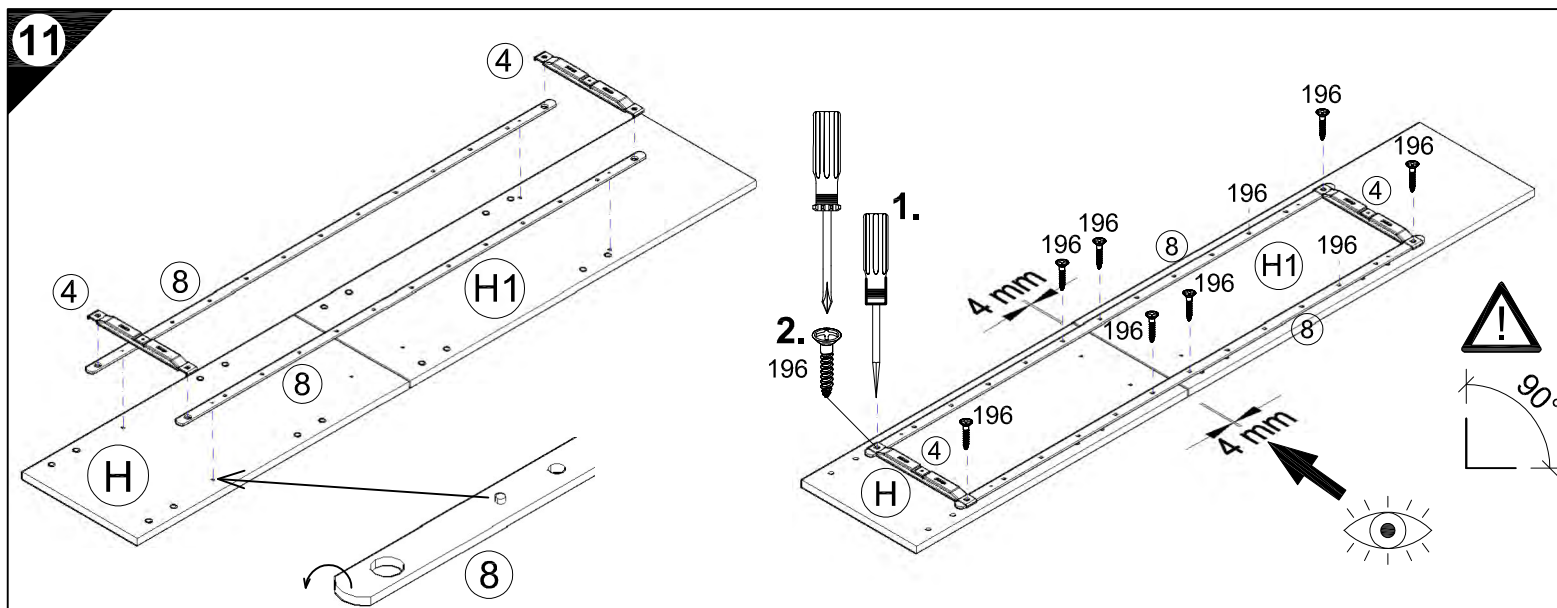
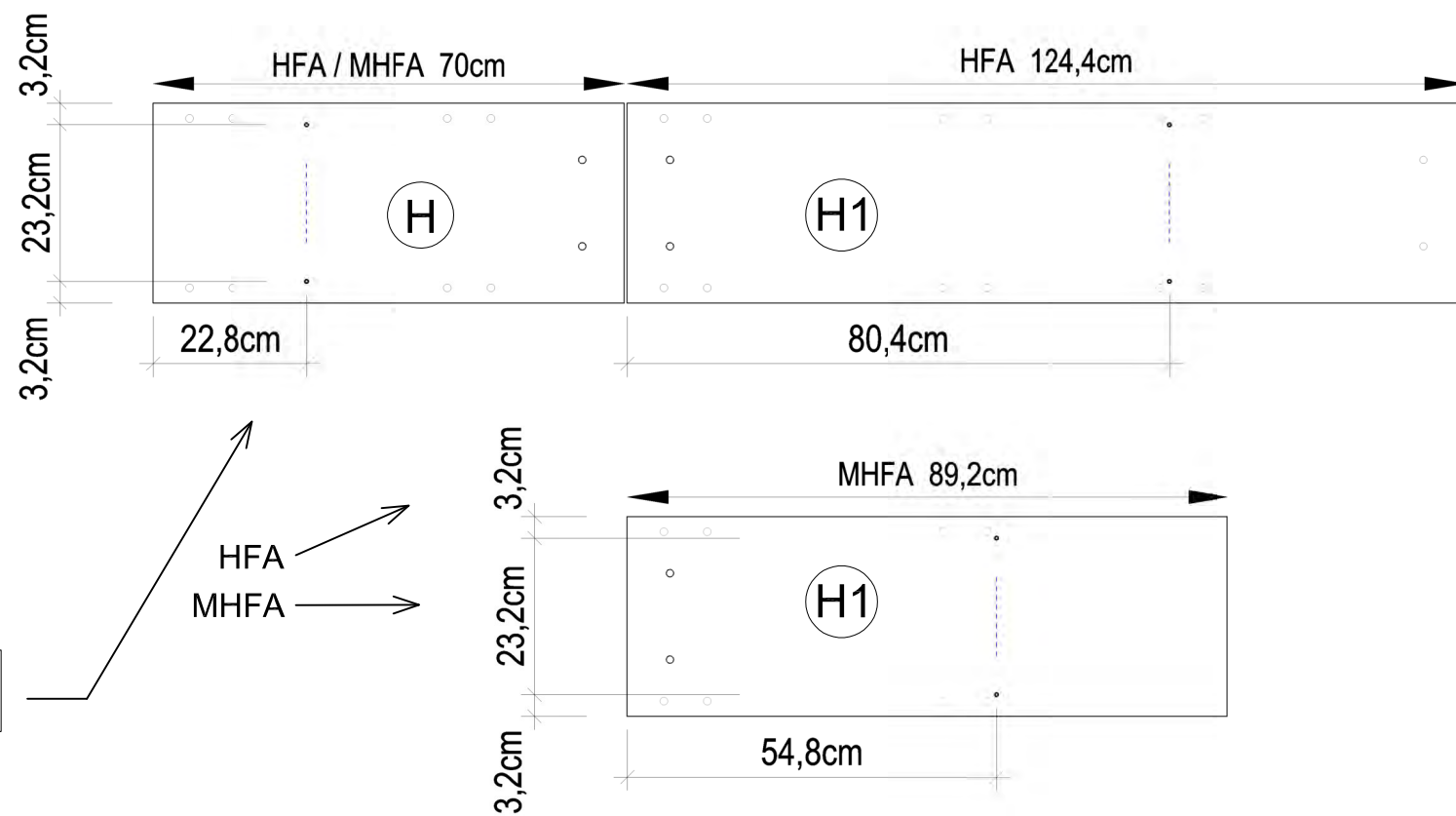
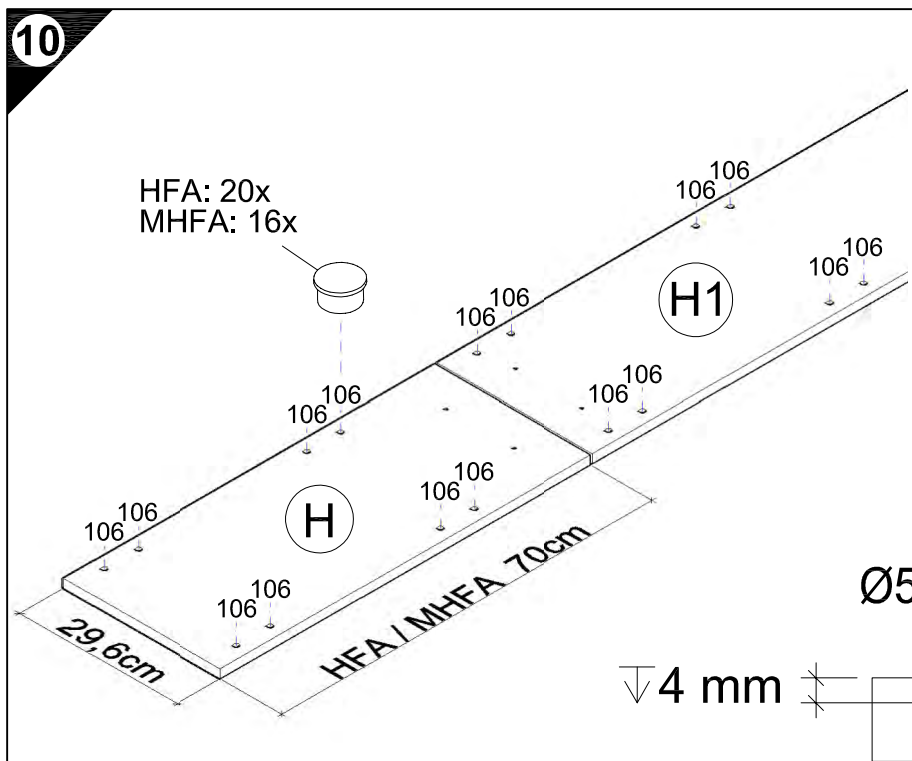
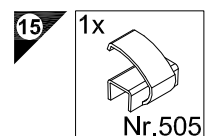
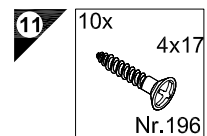
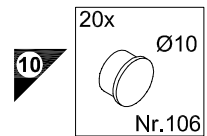

02 / 2019



VS TAL Larder

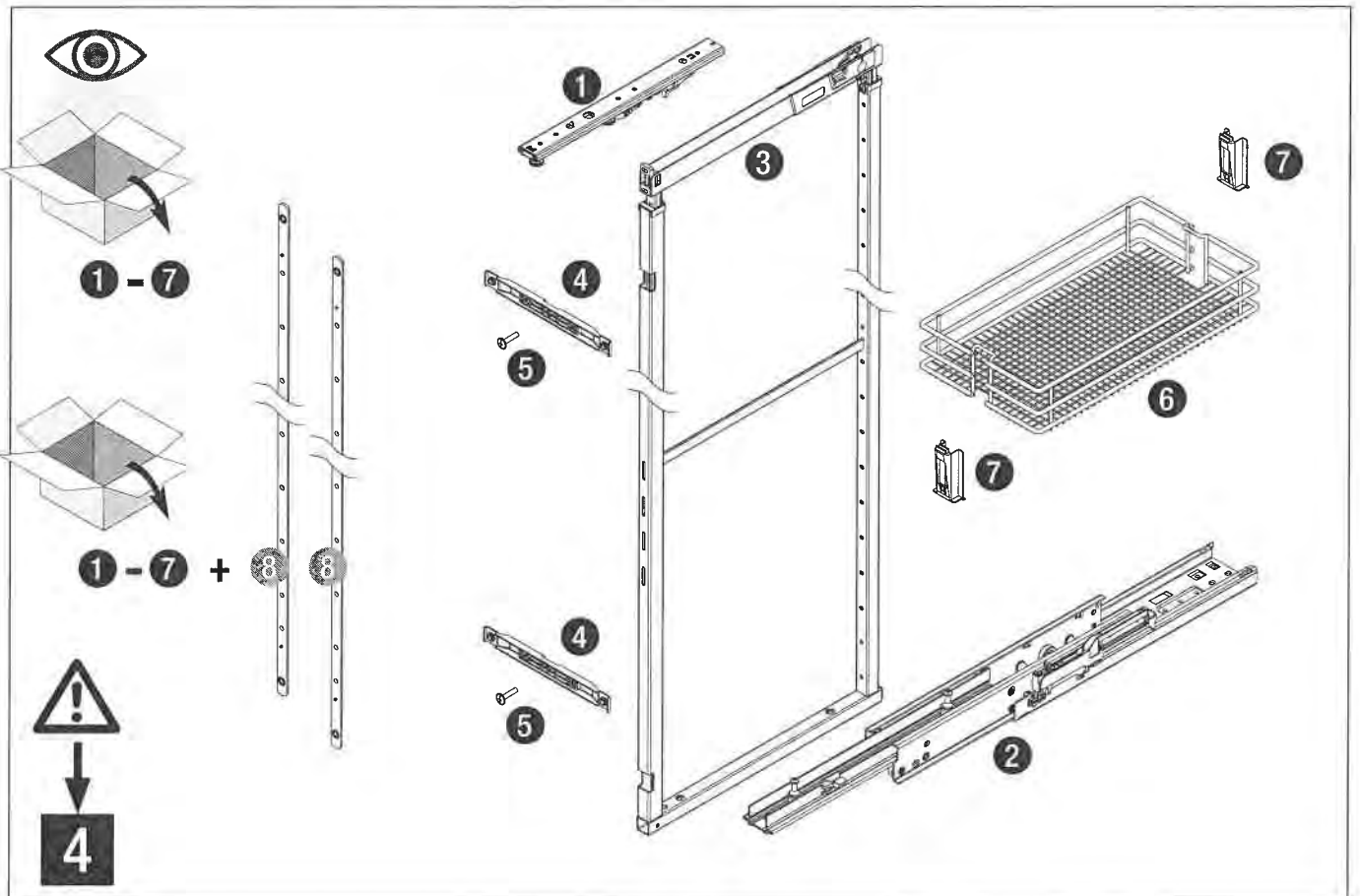
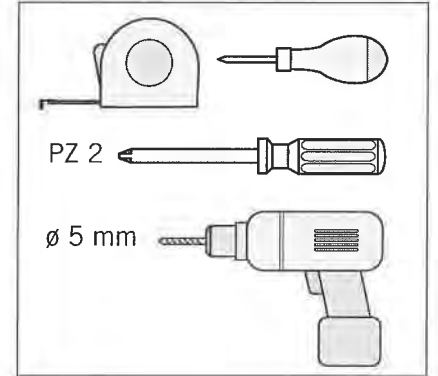
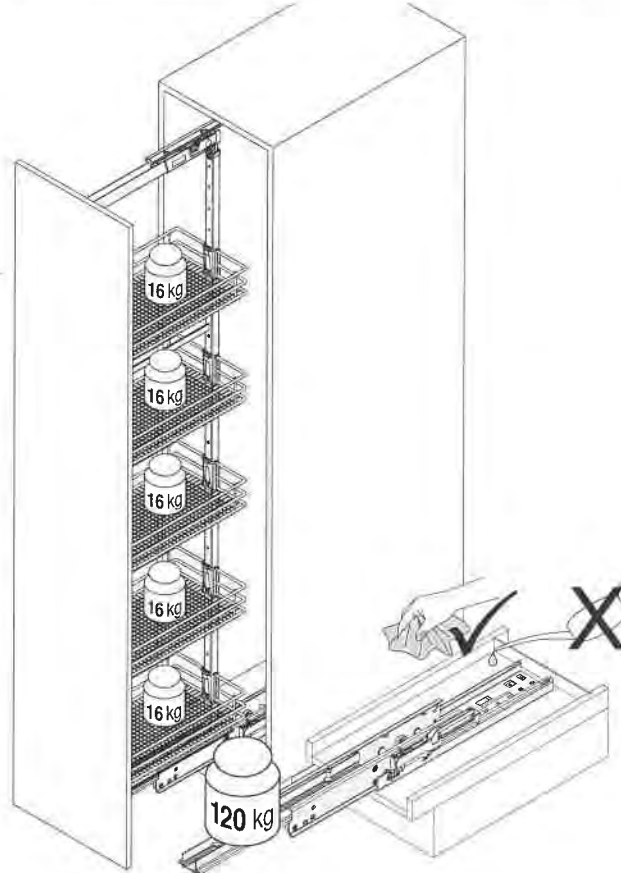
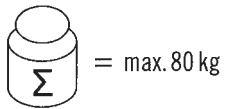
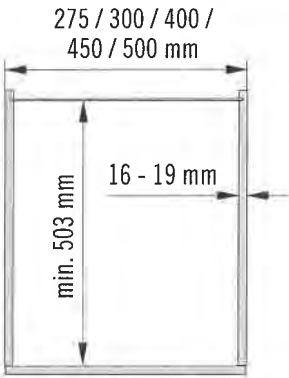

44011747_00

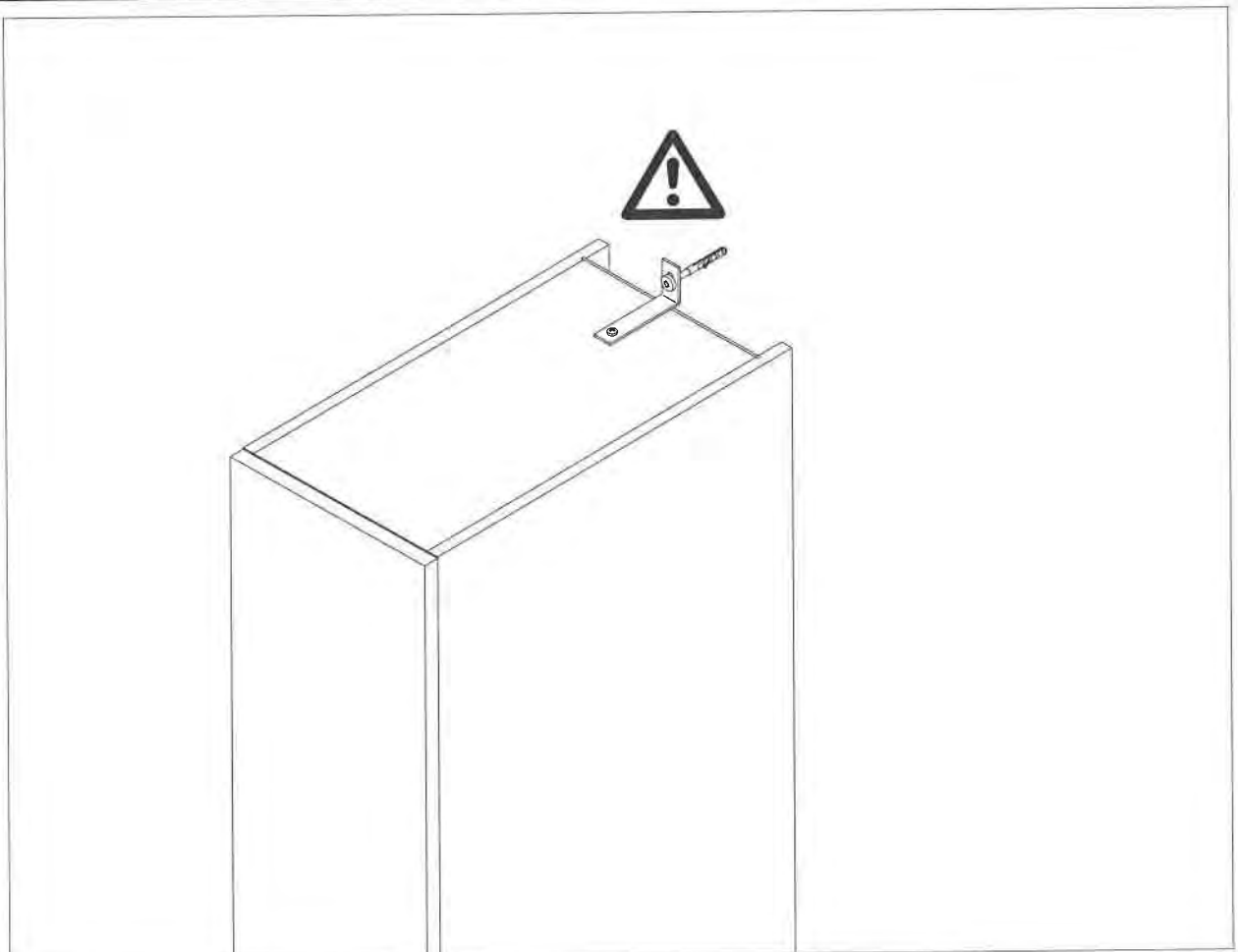
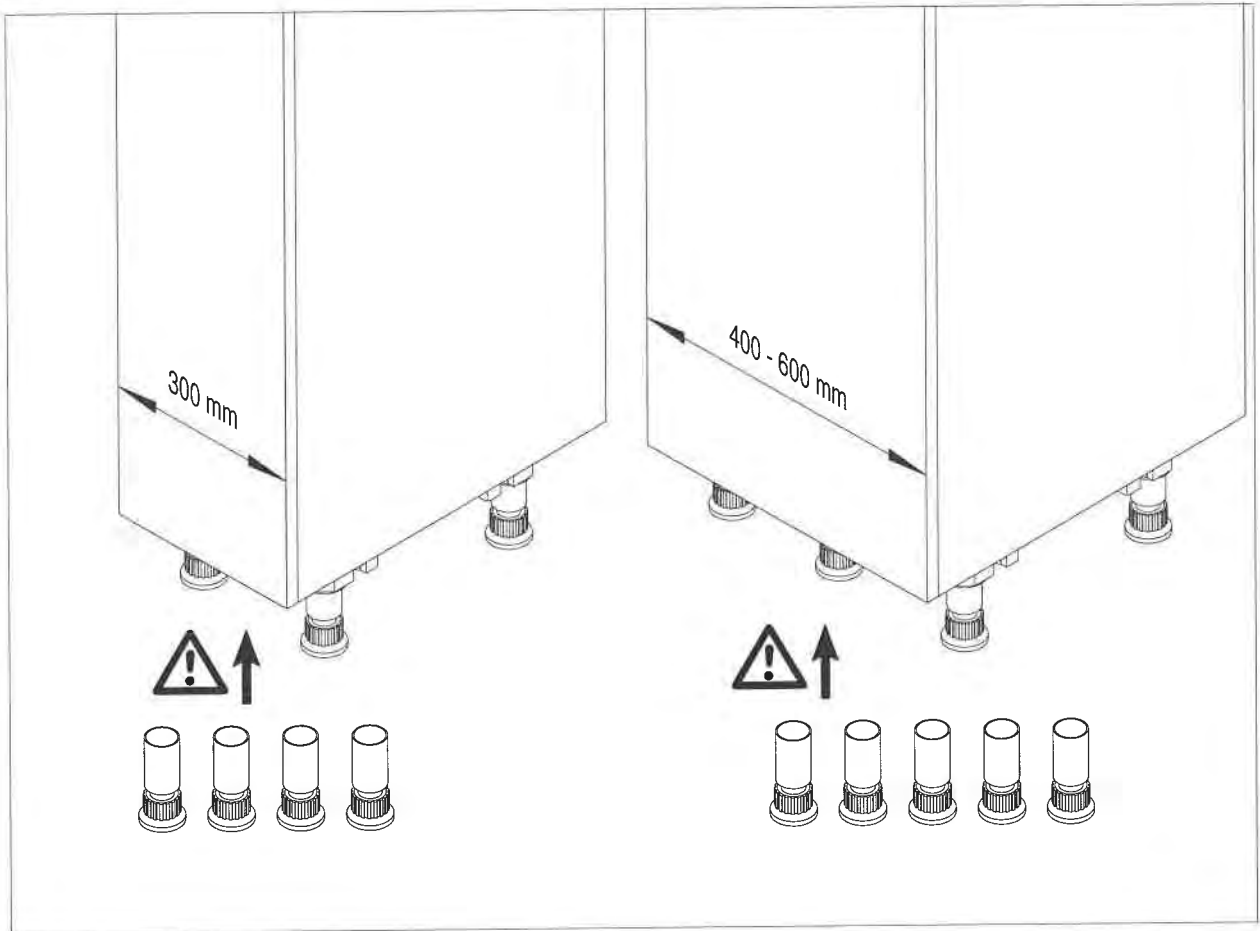

1



A

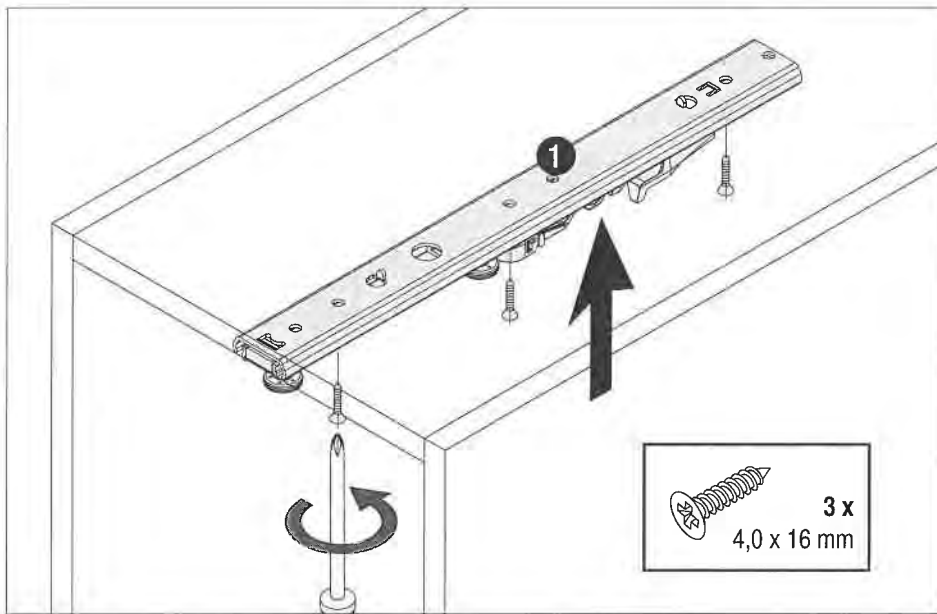

2



B

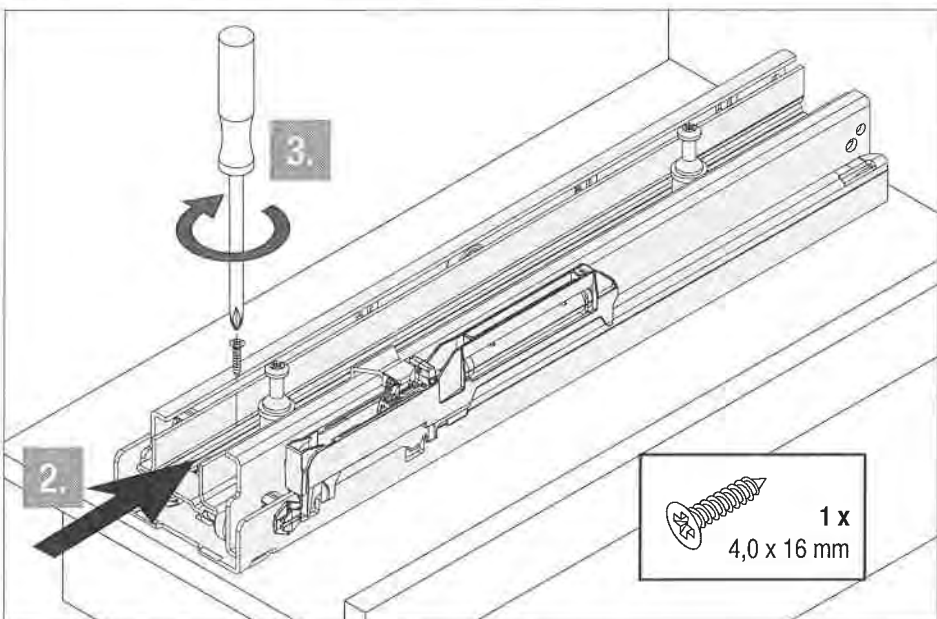
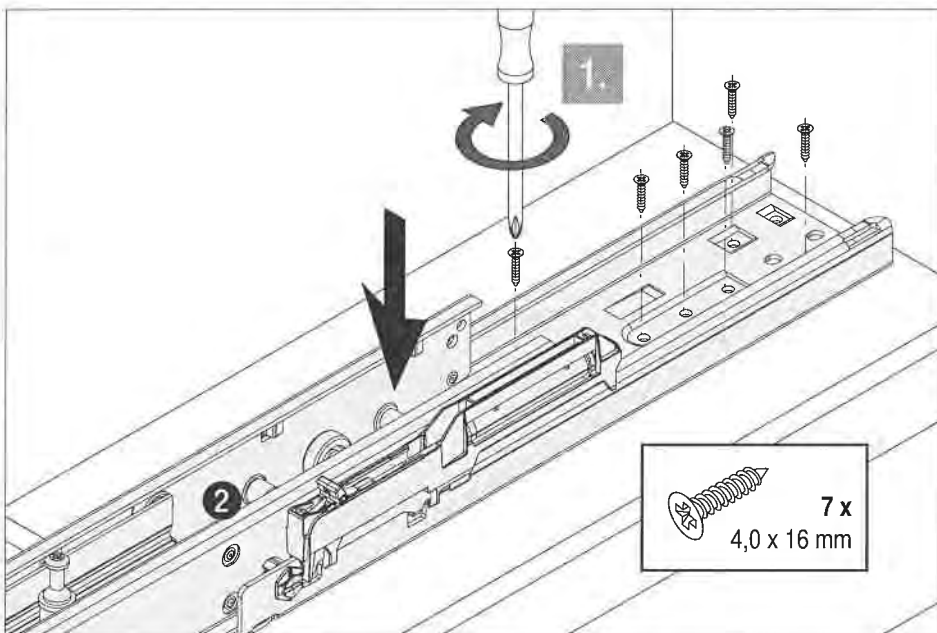

3

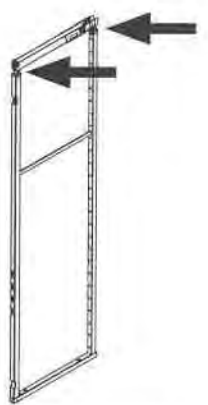
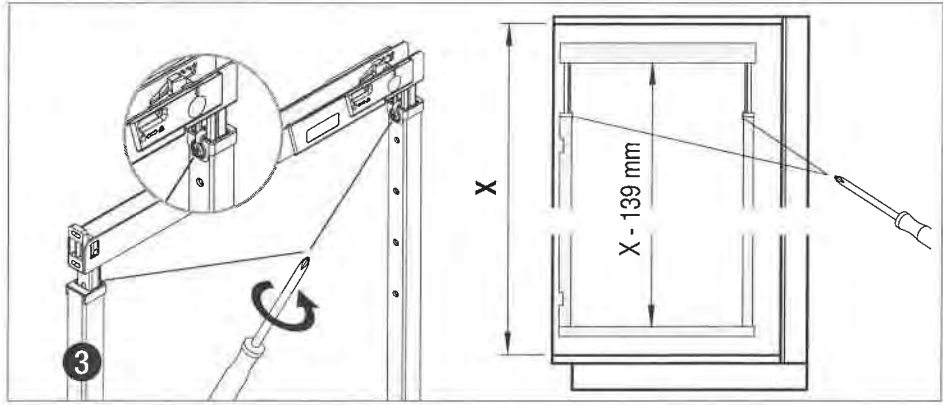

4

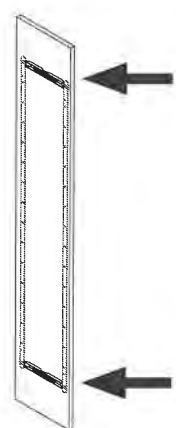
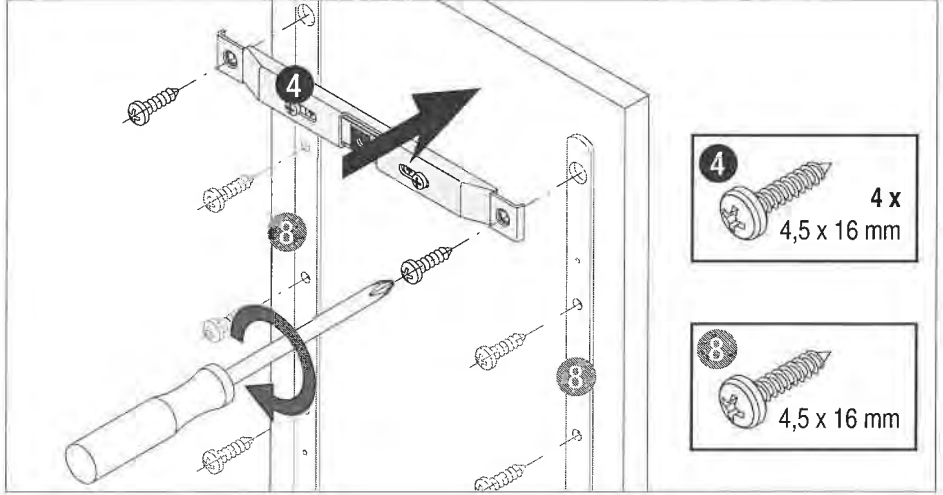

5

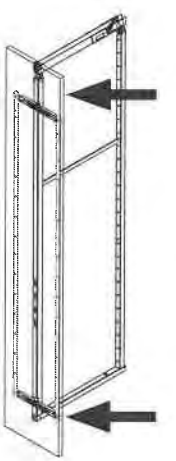
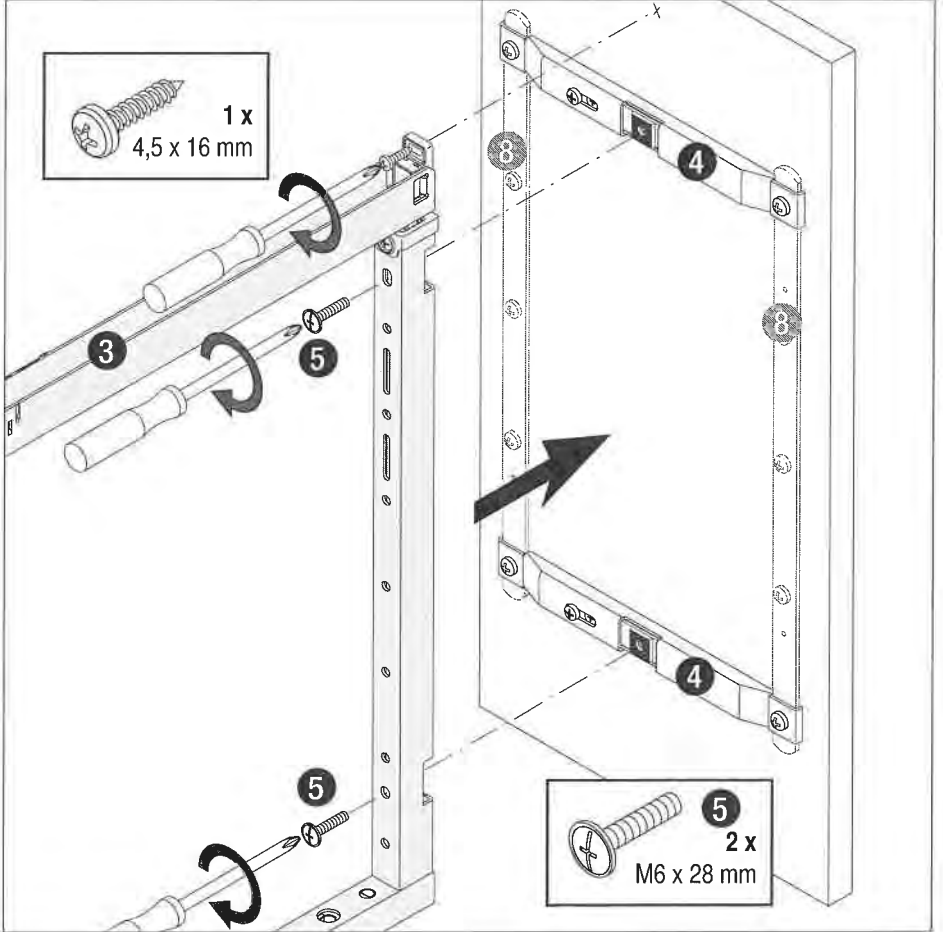

6

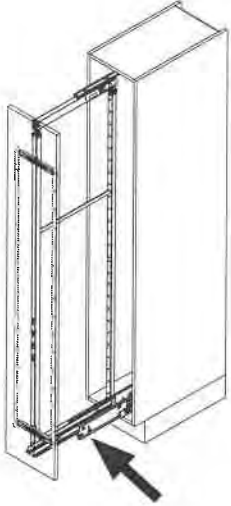
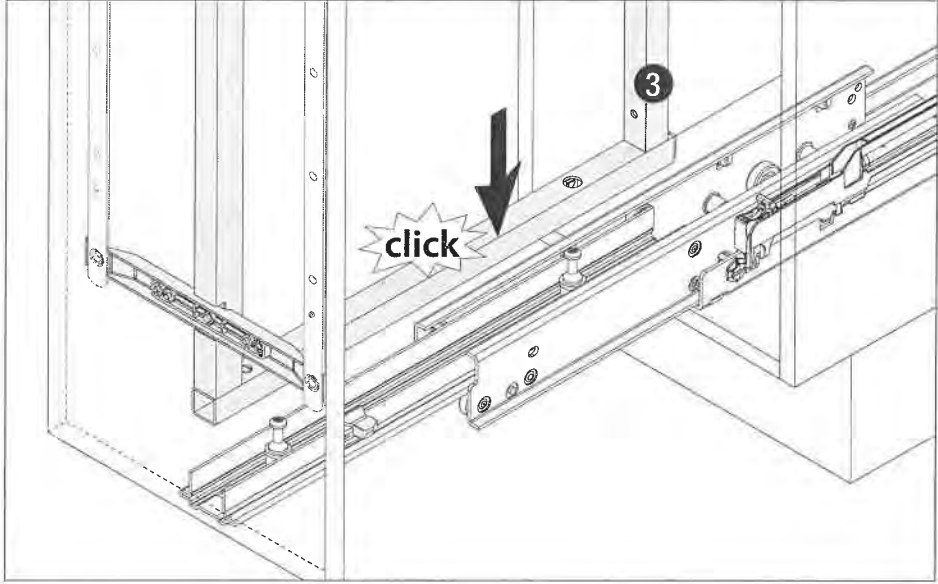

7

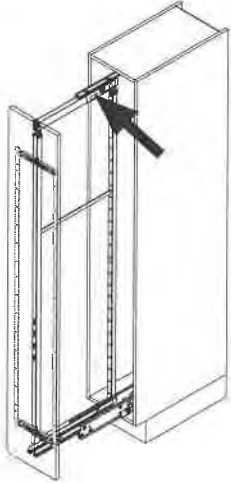
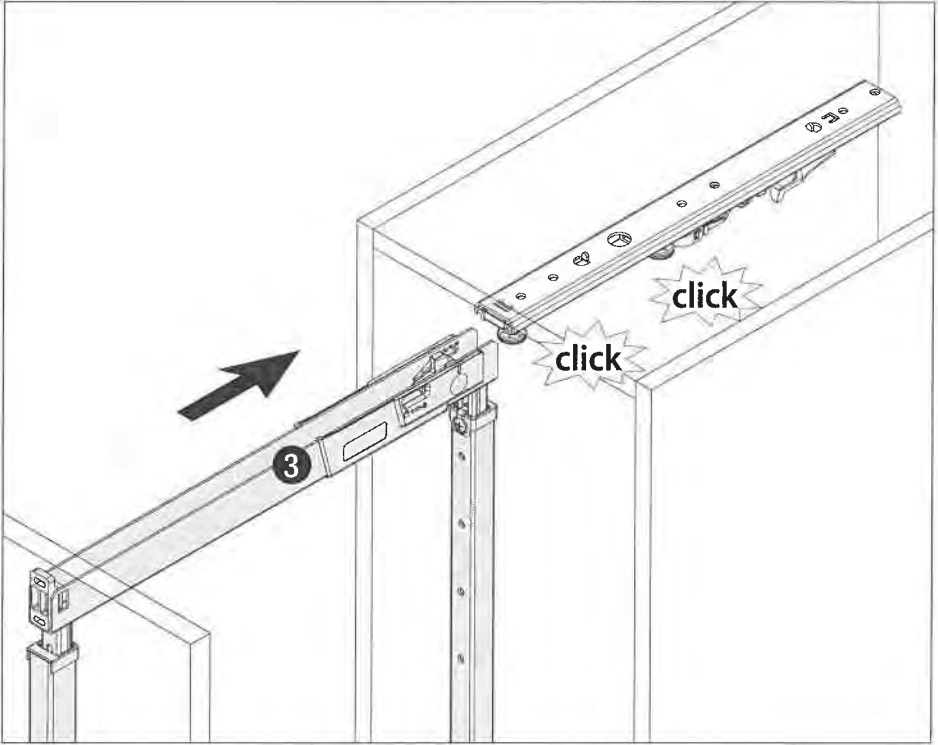

8

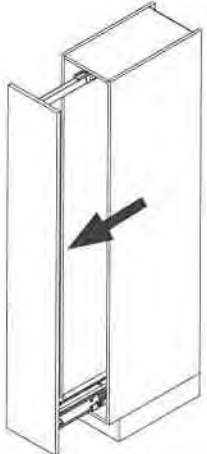
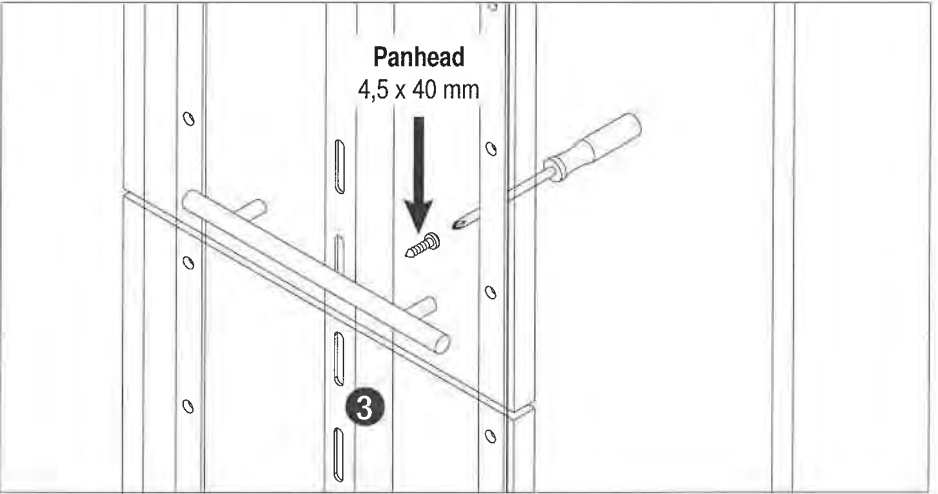

8

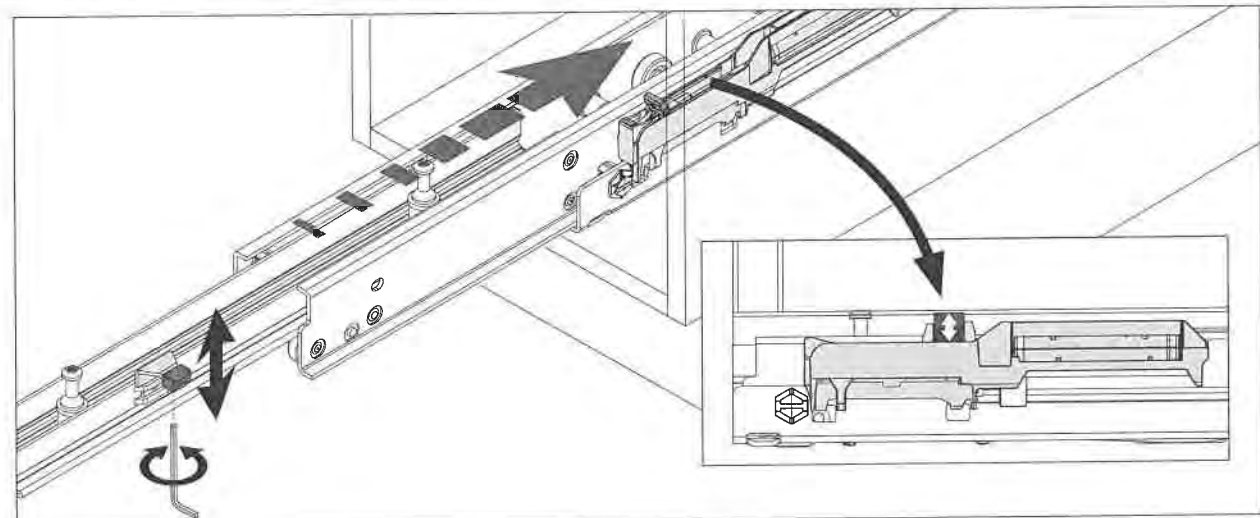
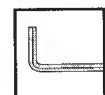
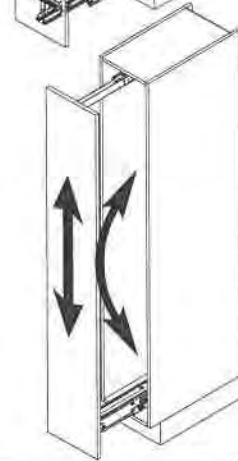
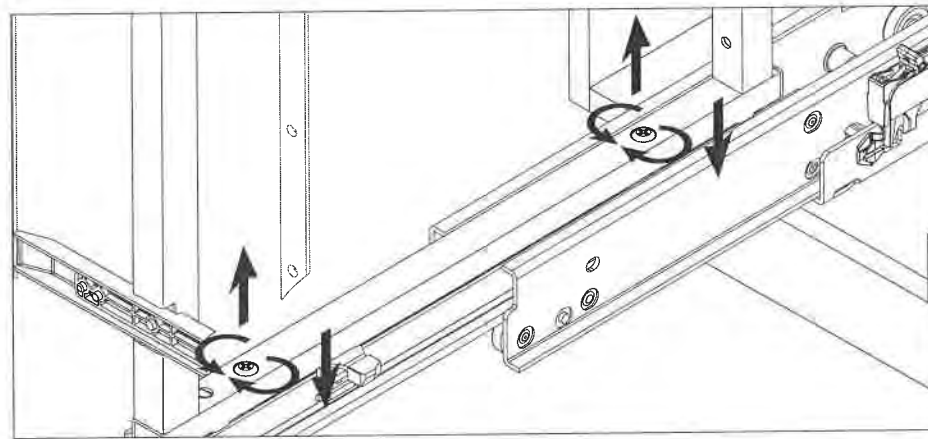
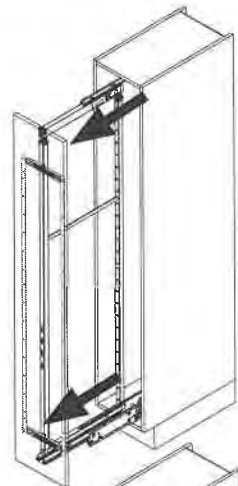
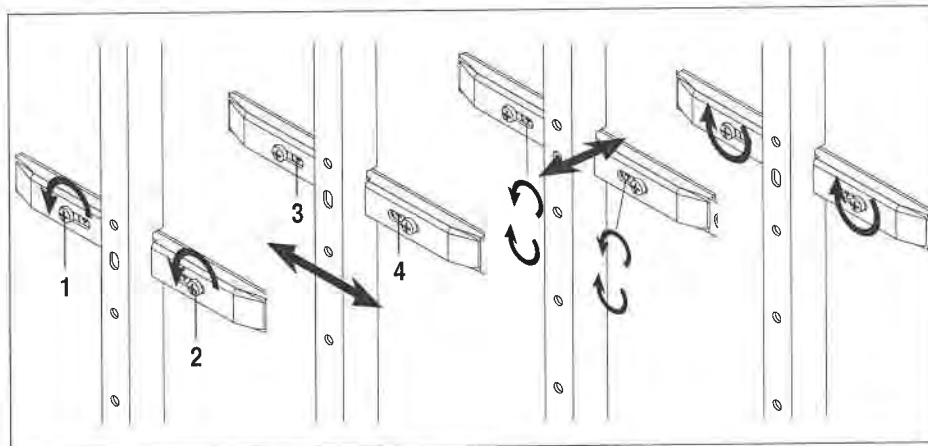
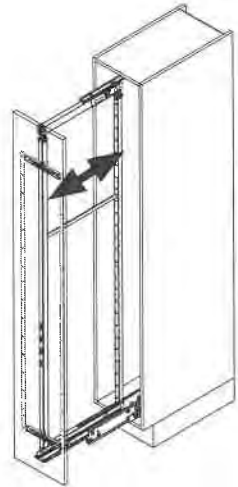
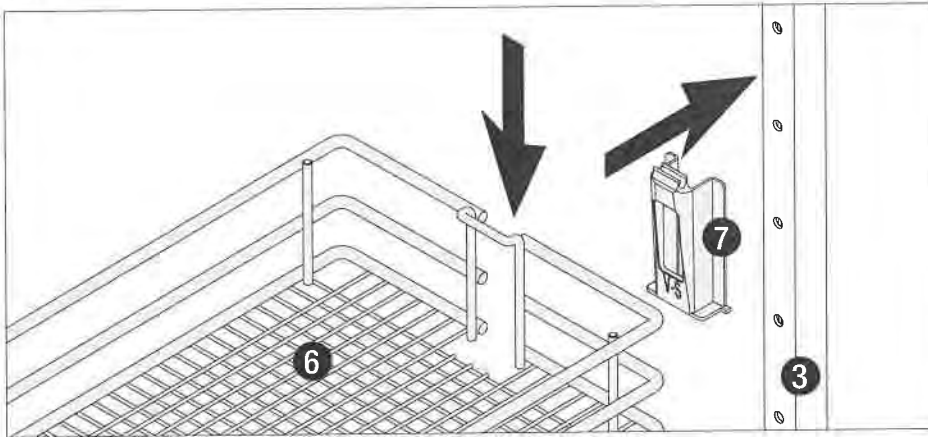

A

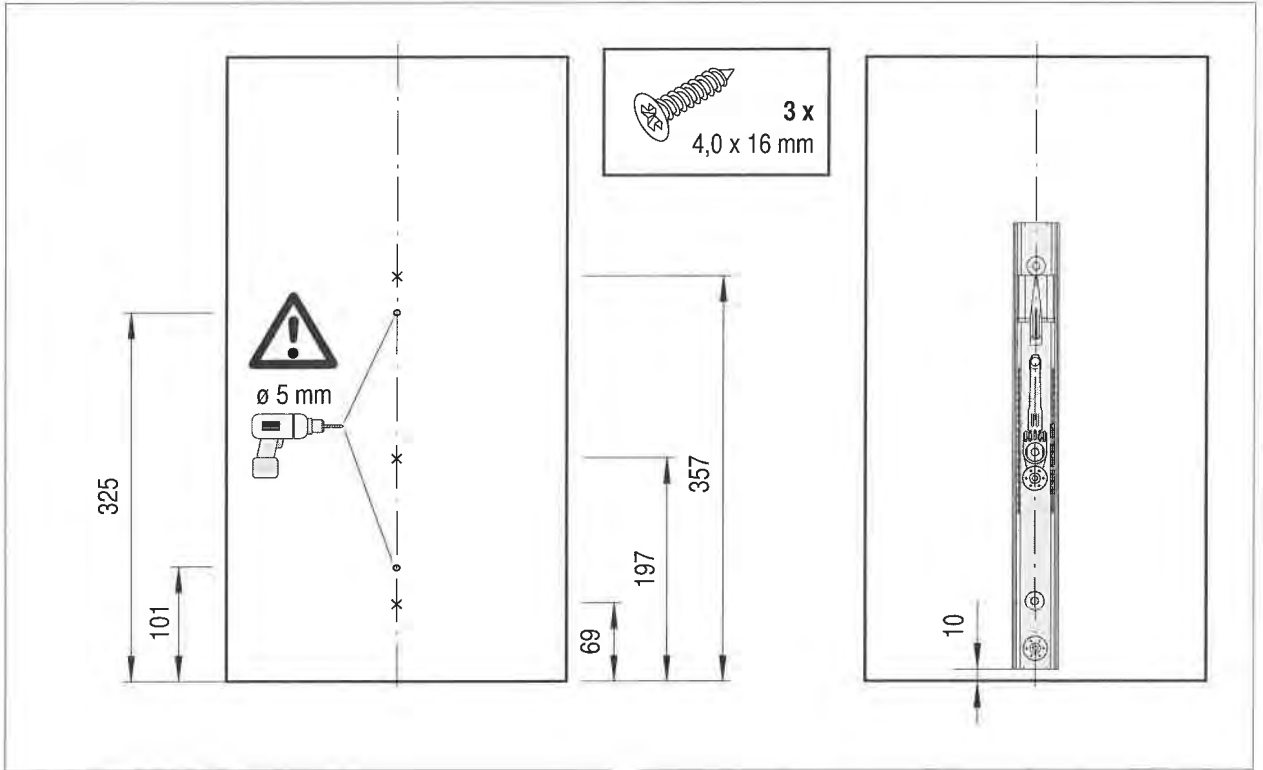

B

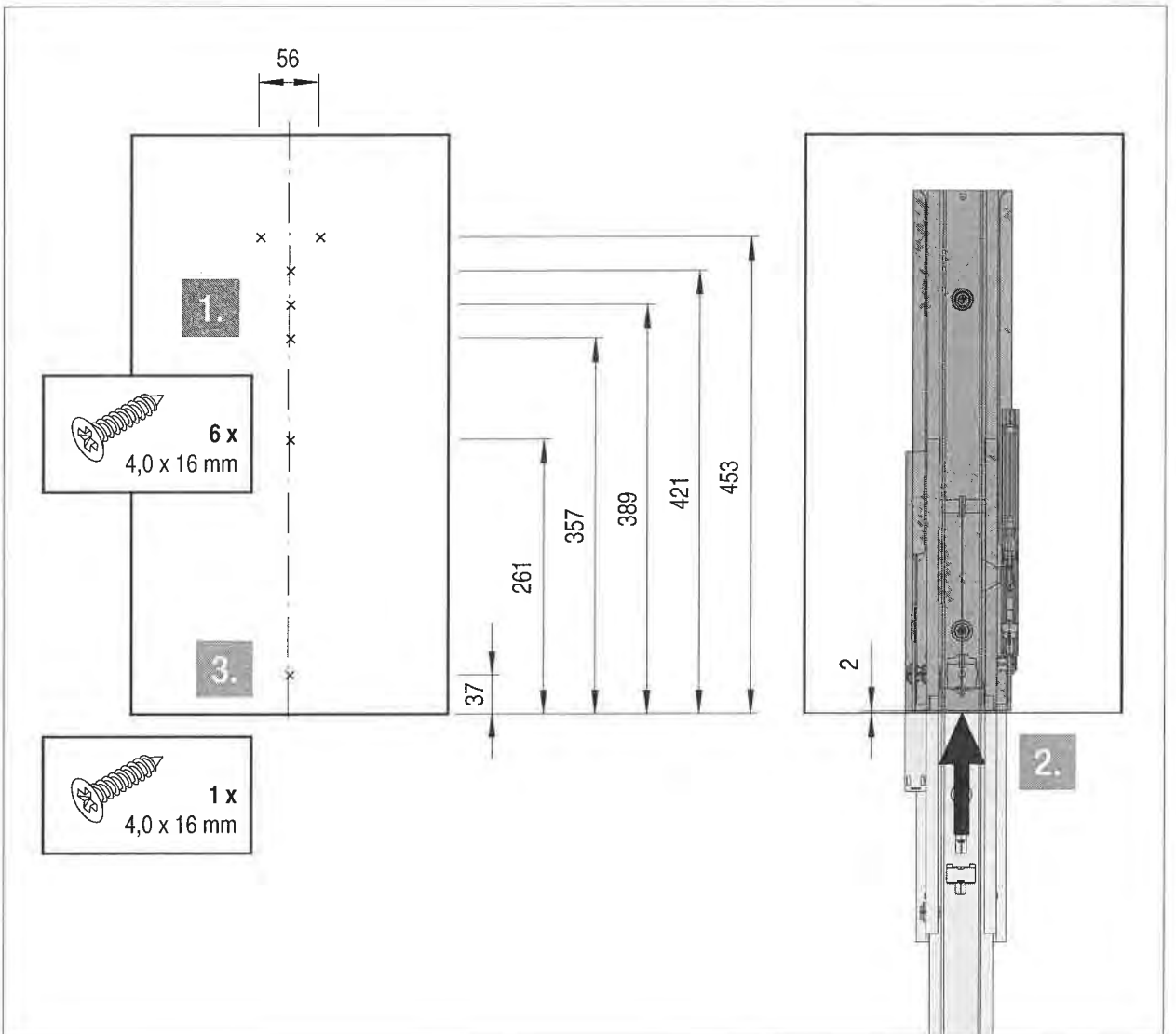
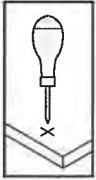

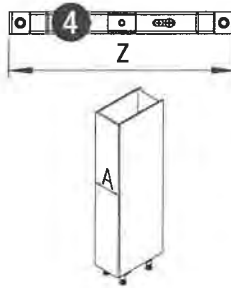
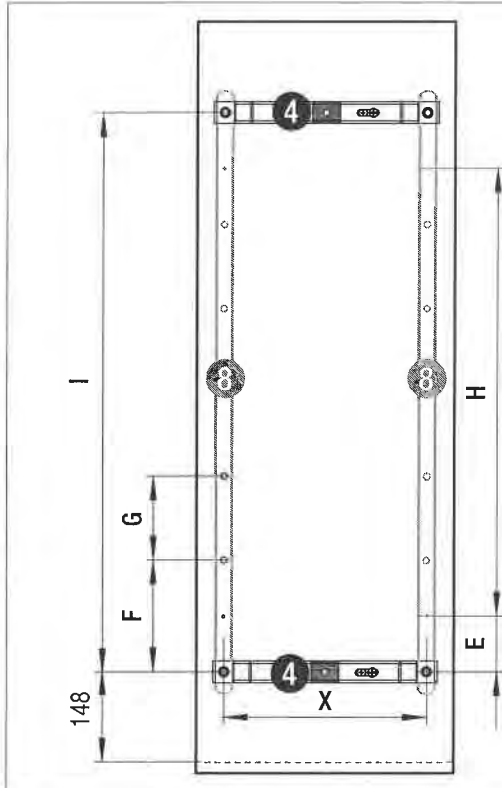

A	X	Z
275	200	225
300	225	250
300	232	257
400	325	350
450	375	400
500	425	450
600	525	550

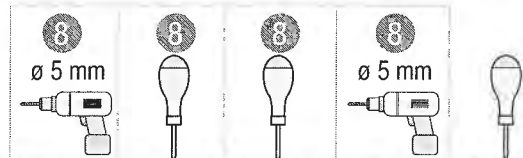

VS TAL Larder	E	F	G	H	I
1	64	96	2 x 96	256	384
2	64	128	4 x 96	512	640
3	64	112	7 x 96	768	896
4	64	96	10 x 96	1024	1152
5	64	128	12 x 96	1280	1408
6	64	96	14 x 96	1408	1536
7	64	96	16 x 96	1600	1728

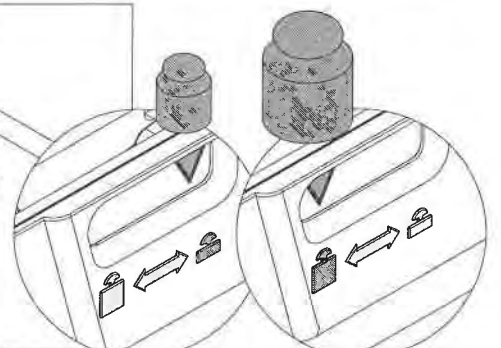
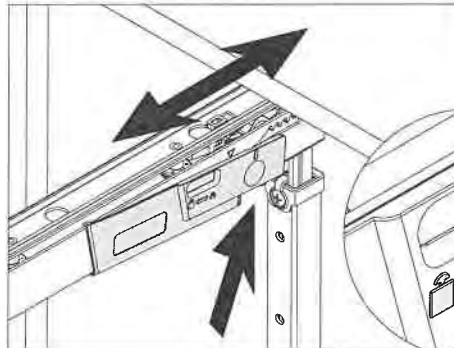
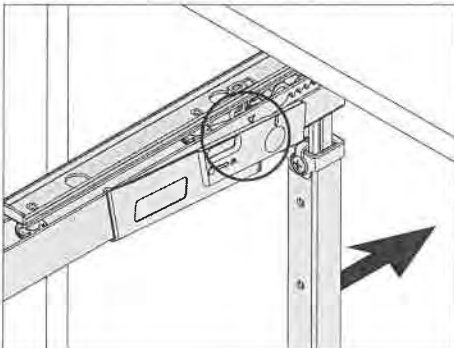
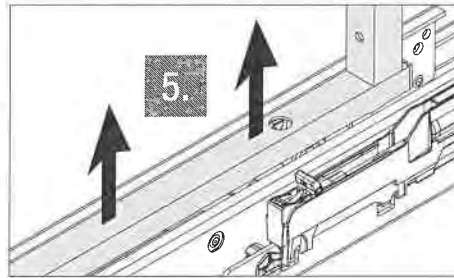
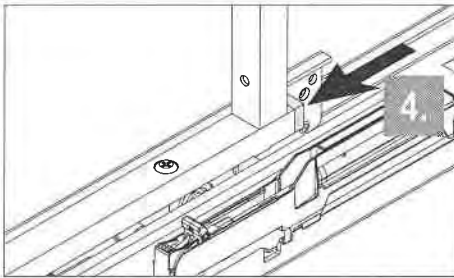
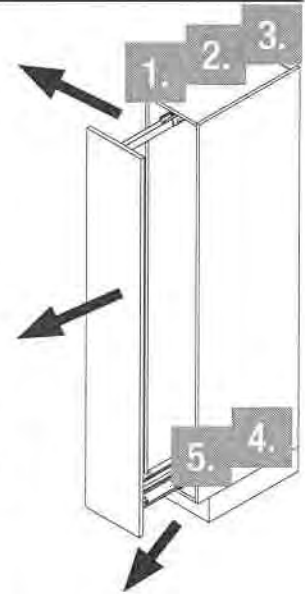
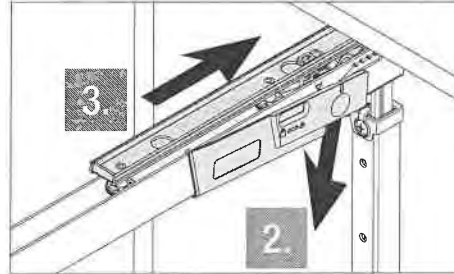
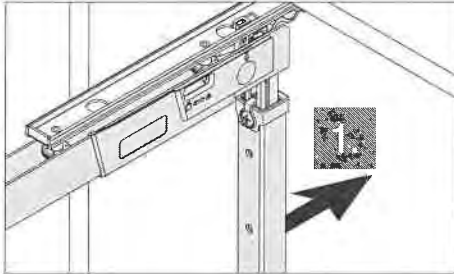

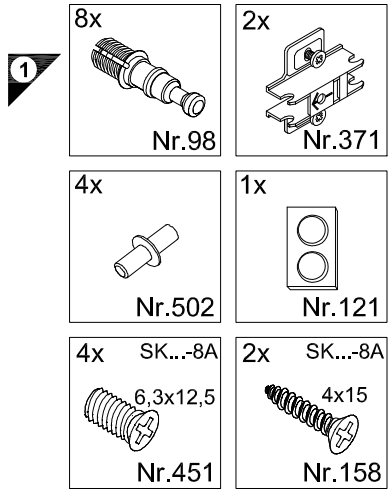
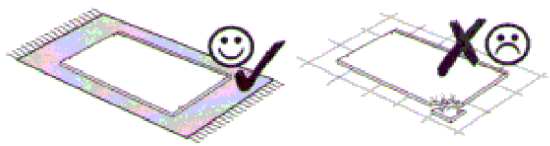
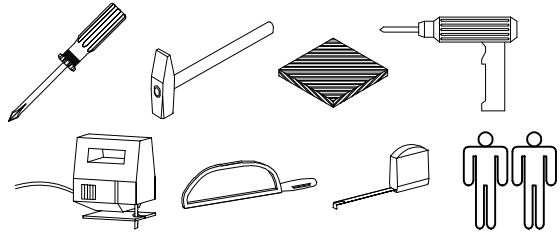

Service-Hotline
01805-678101
0,14€ pro Minute
++49 für Österreich
Auslandstarif pro Minute
service@jaka-bkl.de
voor Nederland en België
00800-40119350
benelux@jaka-bkl.de

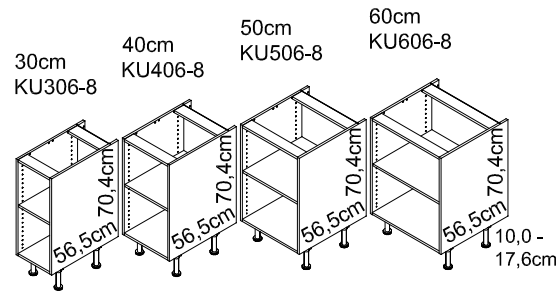

Montageanleitung

U 306...606-3D

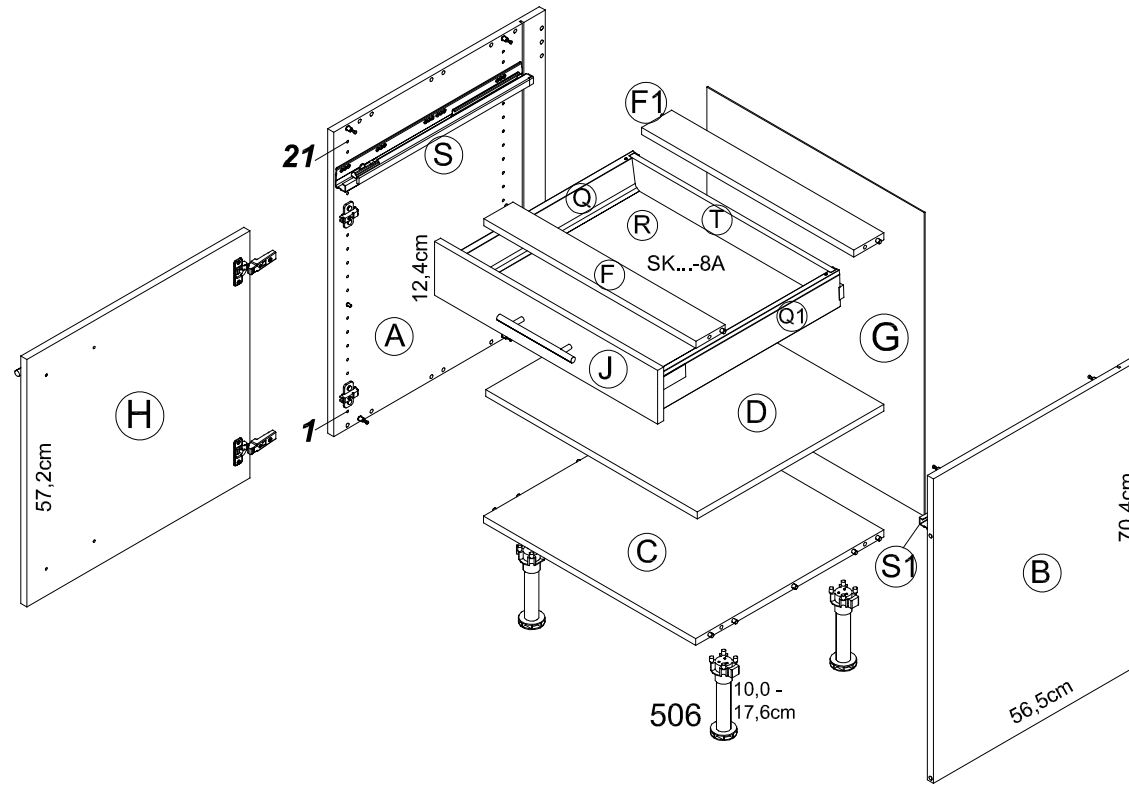
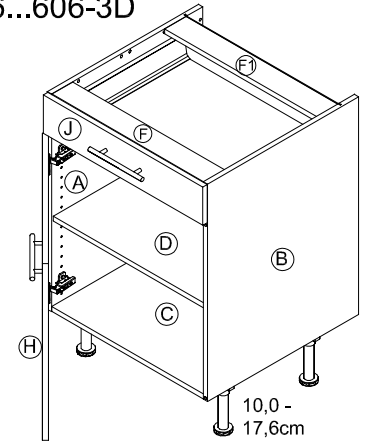

U306-3D
U406-3D
U506-3D
U606-3D

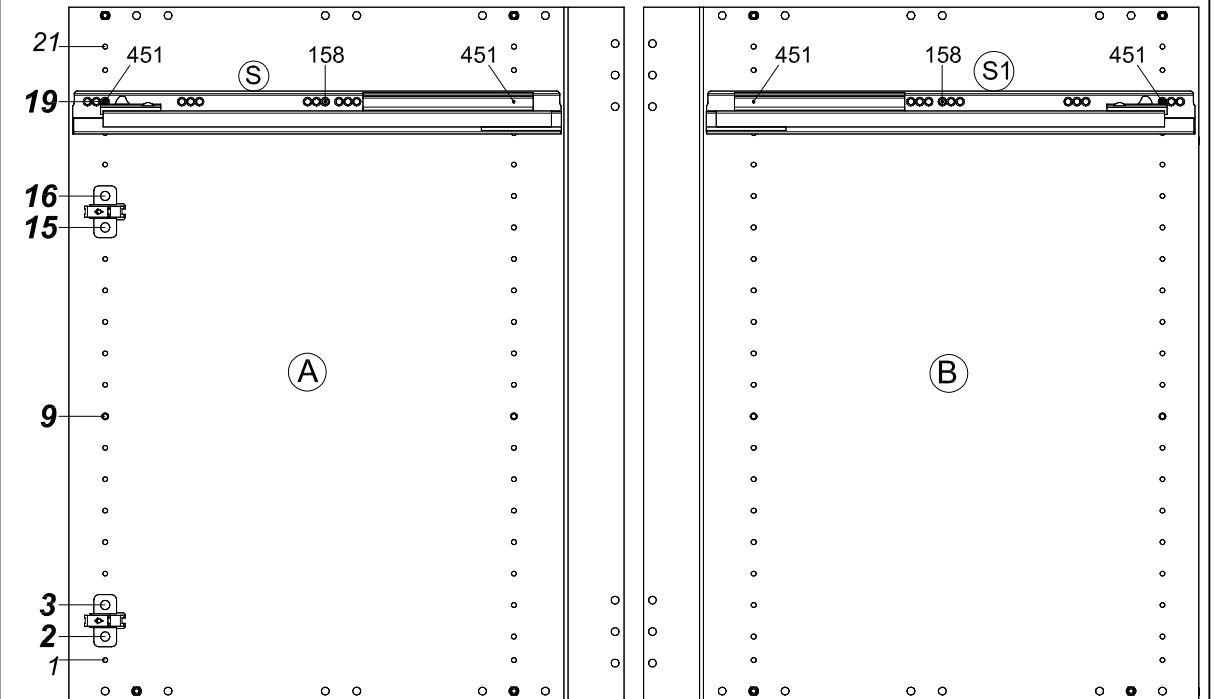
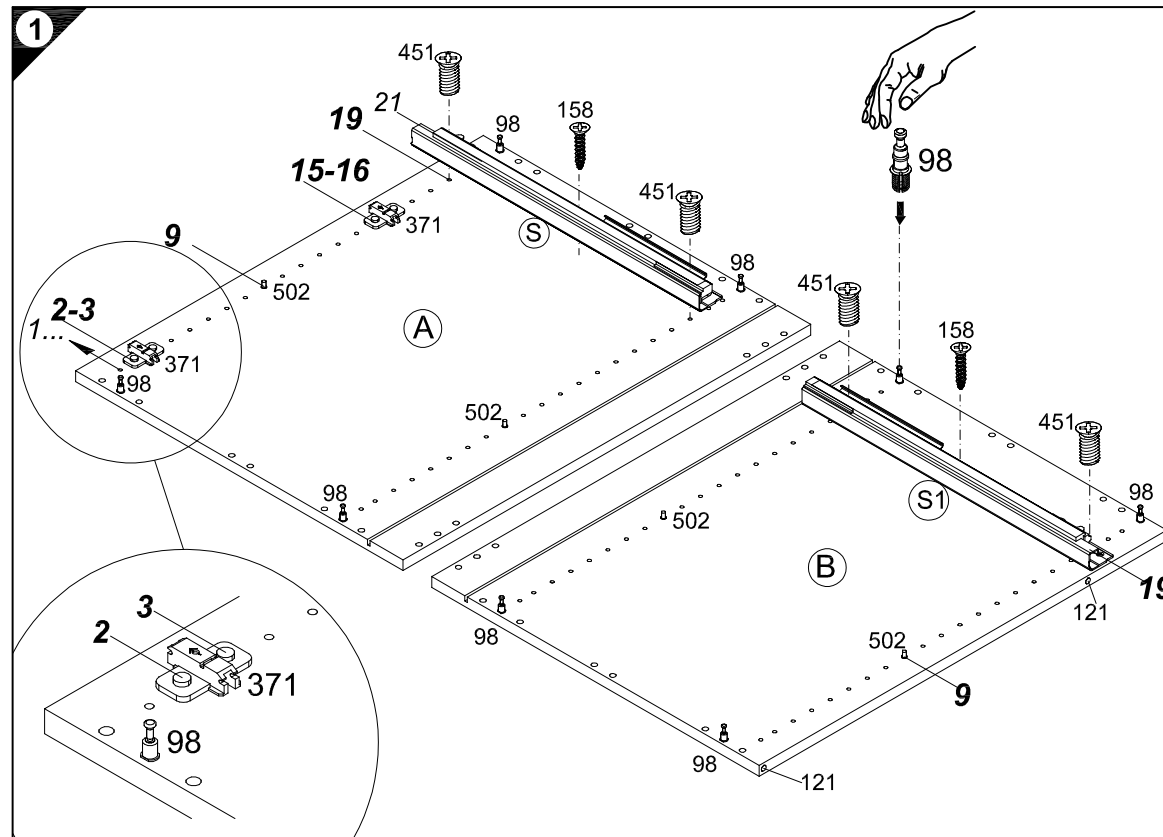

Ersatzteile/Spare parts/pièces de rechange/Reserveonderdelen/Piezas de recambio/Ricambi/Запасные части/Części zamienne/pótkatrészek/Náhradní části/Nadomestni deli/varaosat/reservdelar/náhradné diely/Utilizați piese de schimb/Yedek parçalar

30cm U 306-3D	(A) E941021	(B) E941021	(C) E951216	(D) E950306	(F) E942976	(F1) E952976	(G) E970006	(H) E940614	(J) E940565	(Q) E446918	(Q1) E446919	(R) E541901	(S) E446922	(S1) E446923	(T) E446930
40cm U 406-3D	(A) E941021	(B) E941021	(C) E951215	(D) E950305	(F) E942975	(F1) E952975	(G) E970010	(H) E940613	(J) E940564	(Q) E446918	(Q1) E446919	(R) E541902	(S) E446922	(S1) E446923	(T) E446931
50cm U 506-3D	(A) E941021	(B) E941021	(C) E951224	(D) E950304	(F) E942974	(F1) E952974	(G) E970117	(H) E940612	(J) E940563	(Q) E446918	(Q1) E446919	(R) E541903	(S) E446922	(S1) E446923	(T) E446933
60cm U 606-3D	(A) E941021	(B) E941021	(C) E951223	(D) E950303	(F) E942973	(F1) E952973	(G) E970116	(H) E940611	(J) E940562	(Q) E446918	(Q1) E446919	(R) E541904	(S) E446922	(S1) E446923	(T) E446934

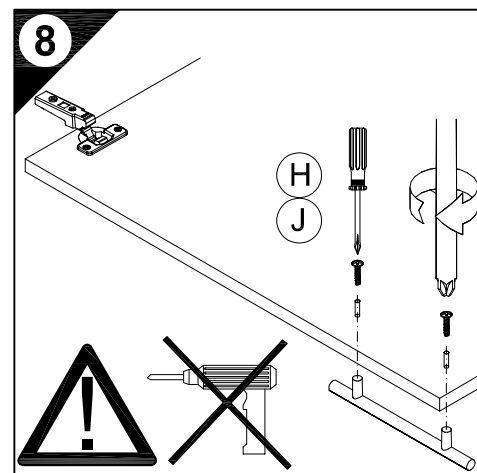
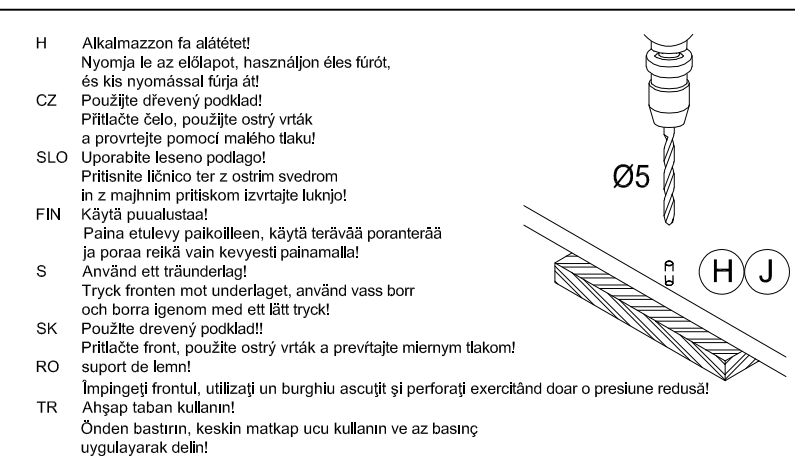
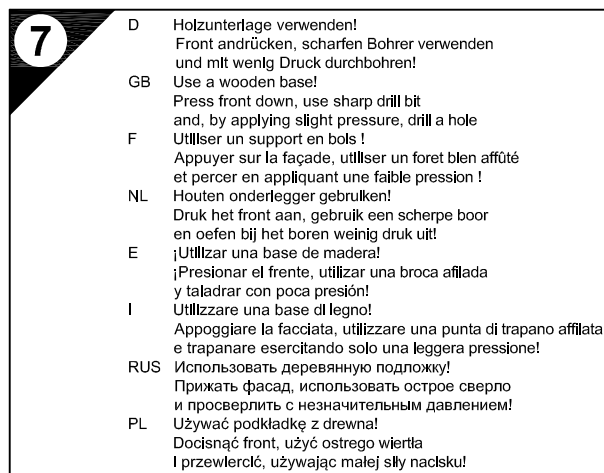
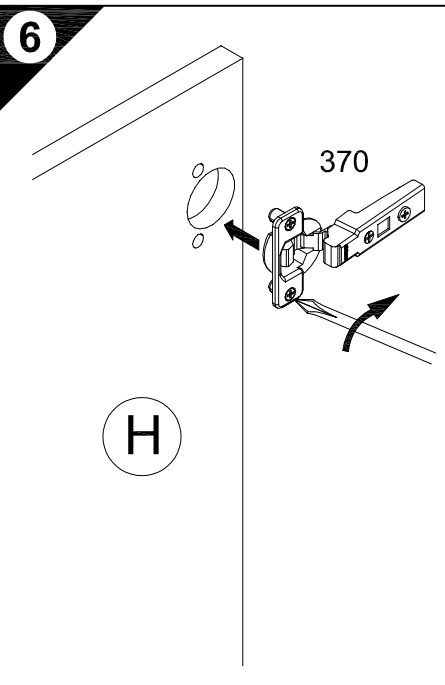
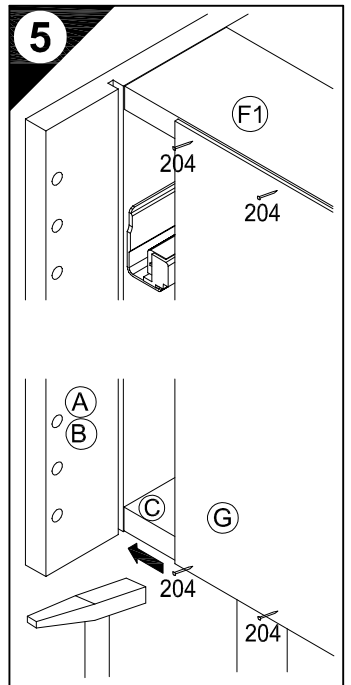
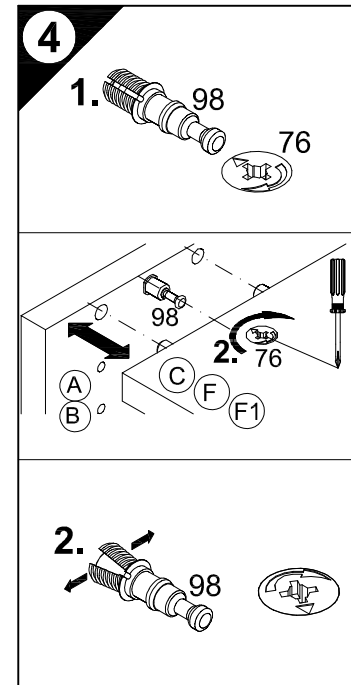
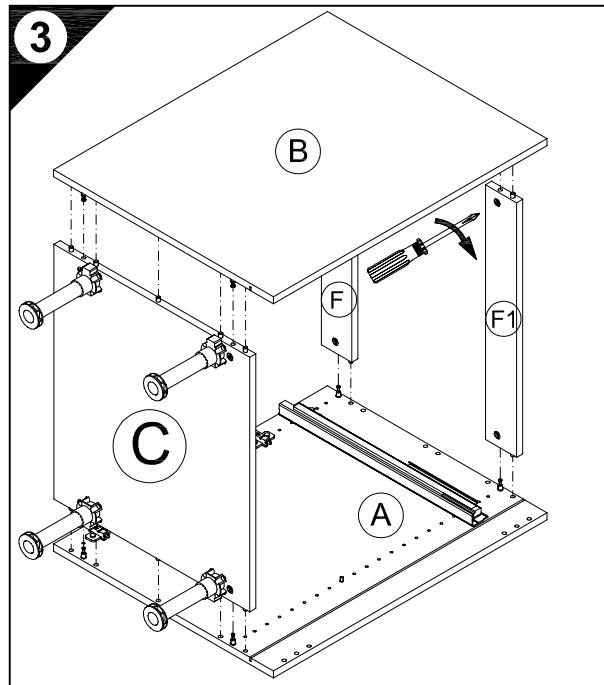
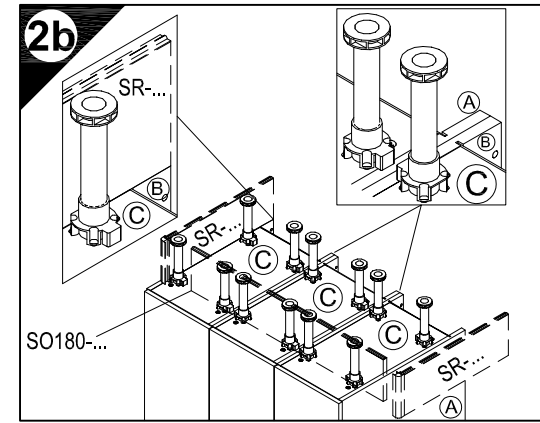
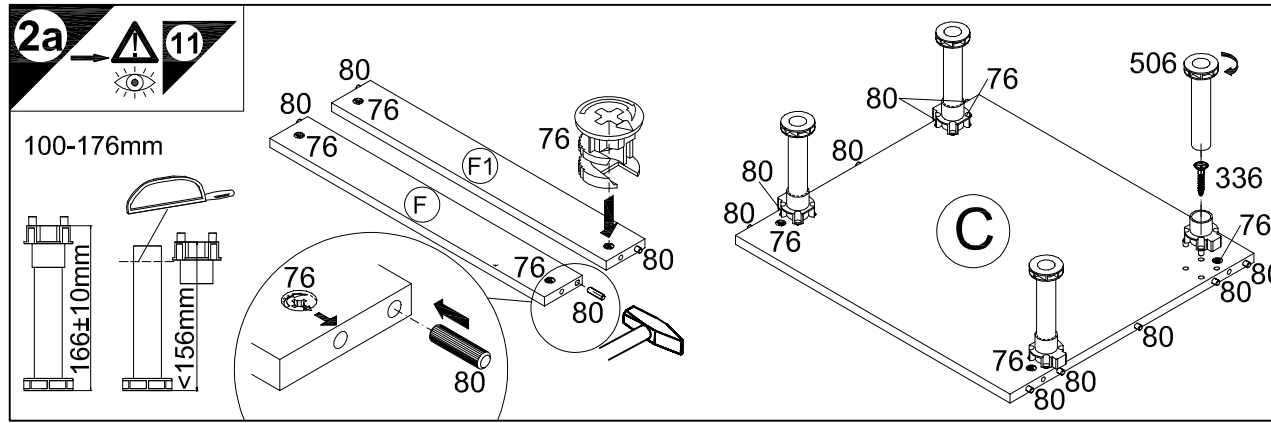
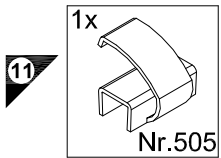
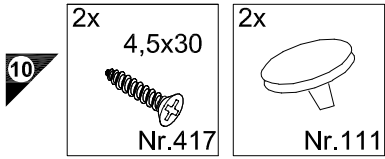
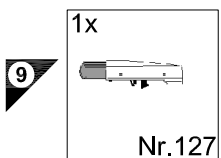
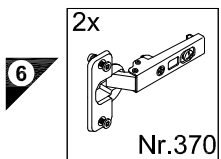
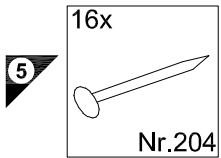
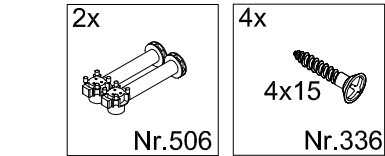
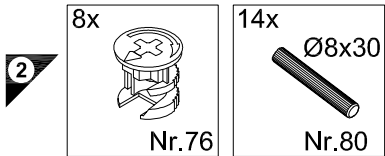

E 948031
Als Zubehör erhältlich
Available as an accessory
Disponibile en accessoire
Verkrijgbaar als accessoire
Se puede obtener como accesorio
Disponibile come accessorio
продаётся как принадлежность
Dostępna jako dodatkowe wyposażenie
Tartozékként kapható
k dodání jako příslušenství
Dobavljivo kot dodatna oprema
Lisävaruste
Kan levereras som tillbehör
Dostupné ako príslušenstvo
Disponibil ca accesoriu
Akcesuar olarak temin alınabilir

D Die äußeren Schränke von miteinander zu einer Zeile verbundenen beliebigen Anzahl von Unterschränken, sowie einzeln stehende Unterschränke müssen mit Wandbefestigungswinkeln versehen werden.

GB The outer cabinets must be fitted with wall mounting brackets if a row of any number of base units or individual base units are to be connected together.

F Les armoires extérieures de tous meubles bas montés en ligne doivent être munies d'équerres de fixation murale. Il en va de même pour les meubles bas indépendants.

NL De buitenste kasten van met elkaar tot een rij verbonden willekeurig aantal onderkasten, evenals apart staande onderkasten, moeten van wandbevestigingsbeugels worden voorzien.

E Los armarios inferiores de los extremos, de una línea de módulos inferiores cuantos se deseen, deberán ser fijados a la pared con escuadras de fijación mural, así como los armarios inferiores que se monten aislados de forma independiente.

I I mobili esterni al pari dei lavabi sparsi devono essere dotati di staffe di fissaggio a muro, se un numero qualsiasi di sottolavabi viene collegato l'uno con l'altro in una fila.

RUS Если несколько напольных шкафов соединено вместе в единую секцию, то крайние шкафы следует привинтить к стене уголками. Отдельно стоящие напольные шкафы также следует крепить к стене уголками.

PL Jeżeli dolne szafki połączone są ze sobą w szereg, to w uchwytach ściennie należy wyposażyć szafki zewnętrzne. Pojedyncze, wolnostojące dolne szafki, również należy wyposażyć w uchwyty.

H A tetszőleges számú, egymáshoz rögzített alsó szekrényekből álló sor szélső szekrényeit, valamint a különálló alsó szekrényeket fali rögzítő profillal kell ellátni.

CZ Ke stěně je nutno úhelníkem připevnit samostatně stojící skříňky a vnější skříňky, pokud jsou spolu s dalšími skříňkami spojeny v jedné řadě.

SLO Zunanje omare se morajo pričvrstiti s pritrilnimi zidnimi kotniki, kadar se povezujejo v eno linijo s poljubnim številom spodnjih omaric. Prav tako, se morajo prostostoječe spodnje omare, pričvrstiti s pritrilnimi zidnimi kotniki.

FIN Aikaapeista muodostuvan kaappirivin uloimmat kaapit on varustettava seinäänkiinnityskulmilla, samoin kuin yksittäiskaapitkin.

S De yttre skåpen måste förses med väggfästevinkel när ett valfritt antal underskåp förbinds till en rad. Även separat stående underskåp måste förses med väggfästevinkel.

SK Na vonkajšie skřinky ľubovoľného počtu spodných skřiniek spojených do jedného radu, ako aj na samostatne stojace spodné skřinky je potrebné namontovať nástenný uholník.

RO Părțile exterioare ale dulapurilor inferioare, indiferent de numărul lor, care sunt legate între ele într-un șir, precum și dulapurile inferioare individuale trebuie prevăzute cu corniere pentru fixarea de perete.

TR Bir hat halinde birbirine bağlanmış olan çeşitli sayıdaki alt dolapların dış bölümlünde kalan dolaplar, tek başına duran alt dolaplar, duvar sabitleme köşebentleri ile duvara bağlanmalıdır.

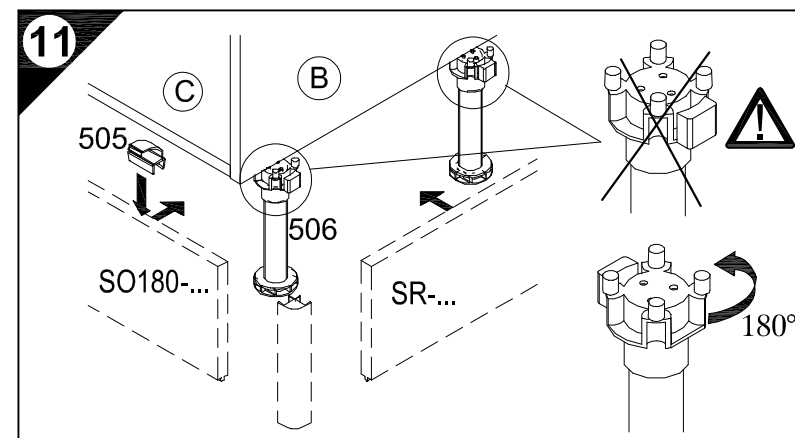
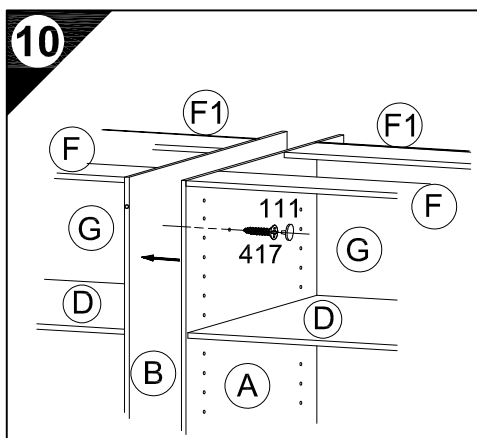
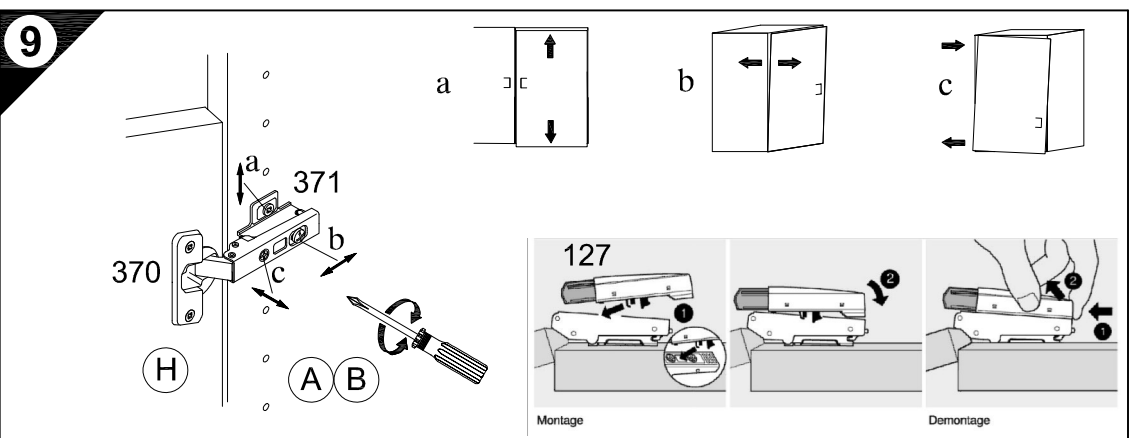

TANDEMBOX Schubkasten / Drawer / Tiroir / Lade

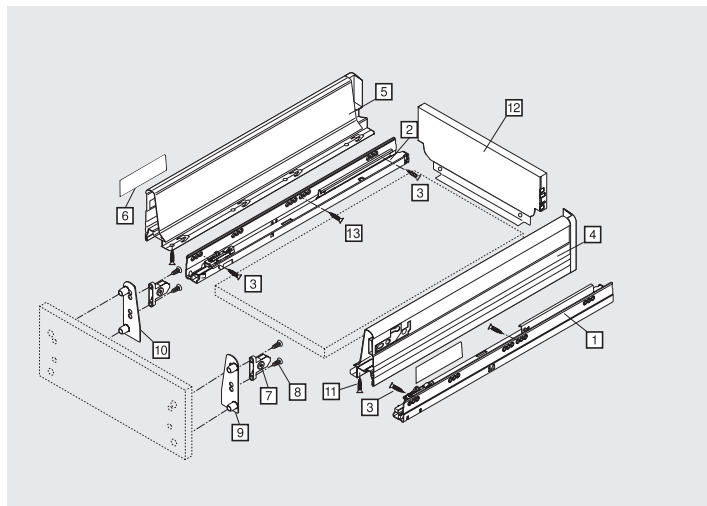

- 1 1x E446923
- 2 1x E446922
- 3 4x Nr. 451
- 4 1x E446919
- 5 1x E446918
- 6 2x Nr. 533
- 7 2x Nr. 526
- 8 4x Nr. 428
- 9 1x Nr. 521
- 10 1x Nr. 522
- 11 2x Nr. 157
- 12 1x E446...
- 13 2x Nr. 158

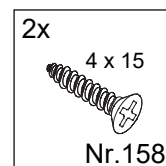
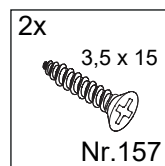
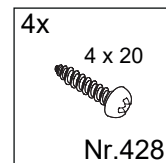
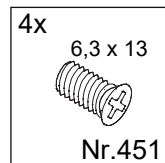

Montage / Assembly / Montage / Montage

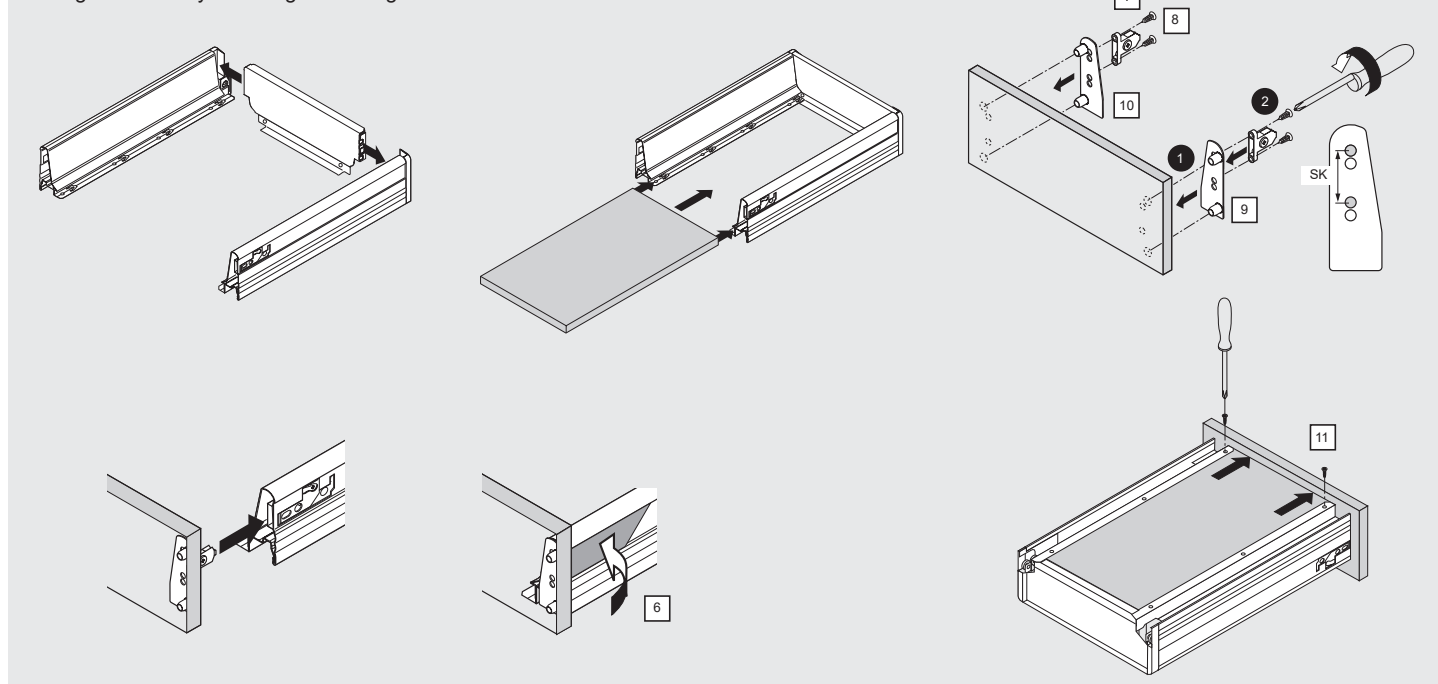

Demontage / Removal / Démontage / Demontage

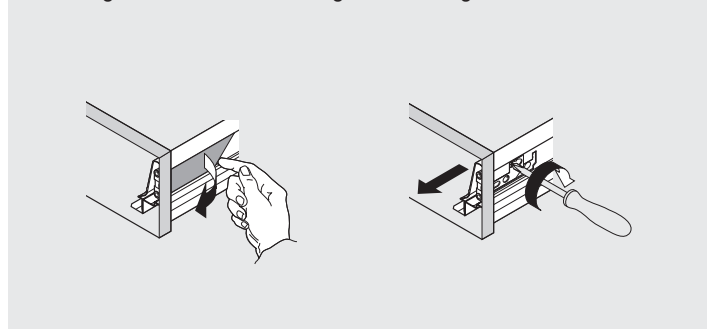

Höhenverstellung / Height adjustment / Réglage en hauteur / Hoogteverstelling

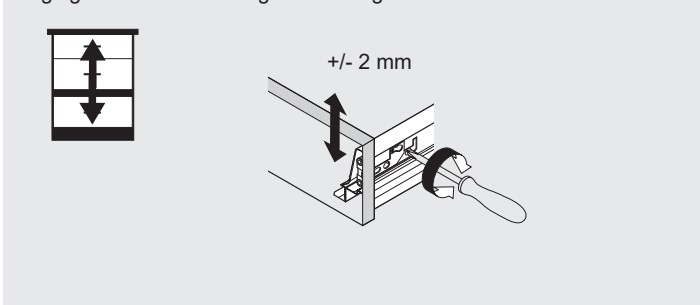

Seitenverstellung / Side adjustment / Réglage latéral / Zijdelingse verstelling

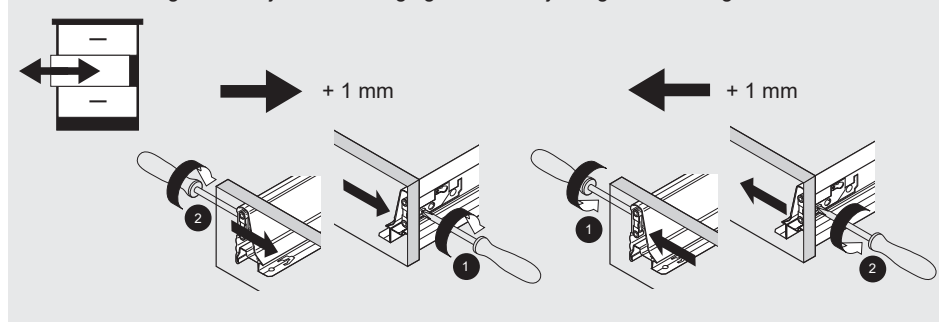

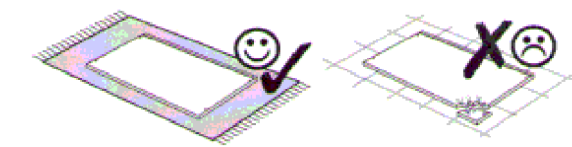
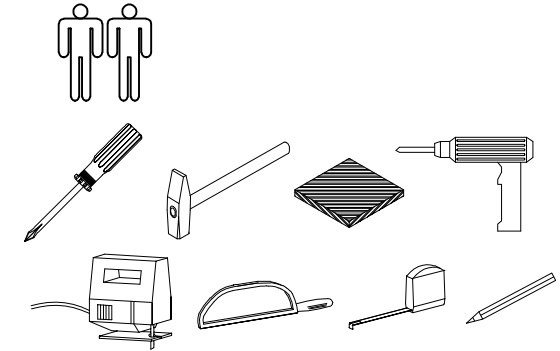

8x Nr.98	4x KB60-8 6,3x11,5 Nr.535	
2x WS-8 Nr.523	2x WS-8 6,3x13 Nr.274	2x WS-8 4x15 Nr.336
6x Nr.315	12x 3,5x15 Nr.181	

Service-Hotline
 01805-678101
 0,14€ pro Minute
+49 für Österreich
 Auslandstarif pro Minute
service@jaka-bkl.de
 voor Nederland en België
00800-40119350
benelux@jaka-bkl.de

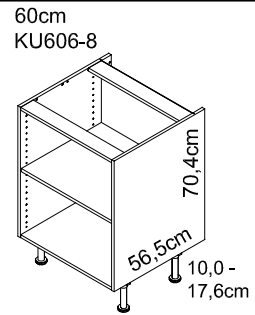

Montageanleitung

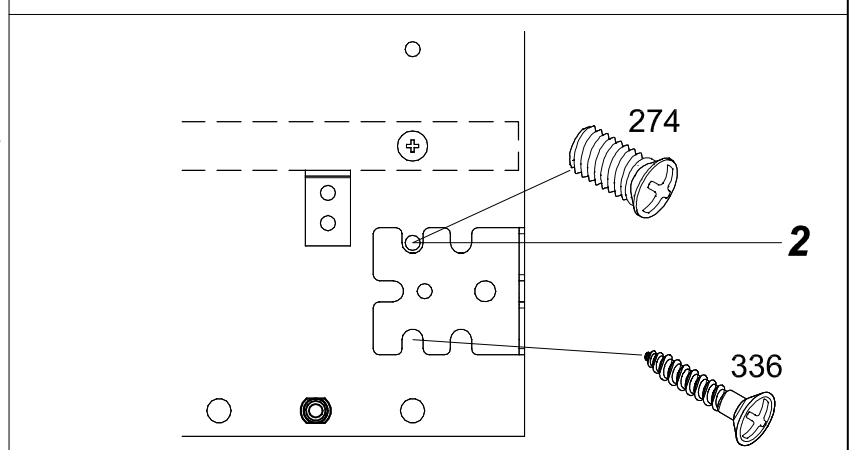
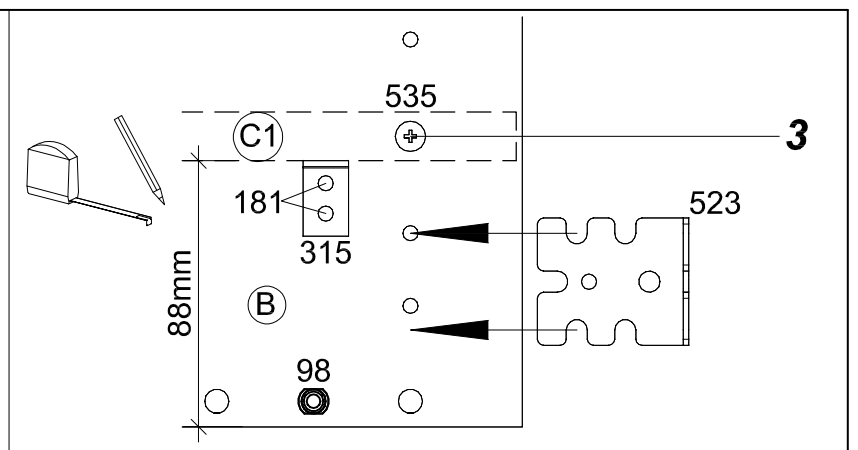
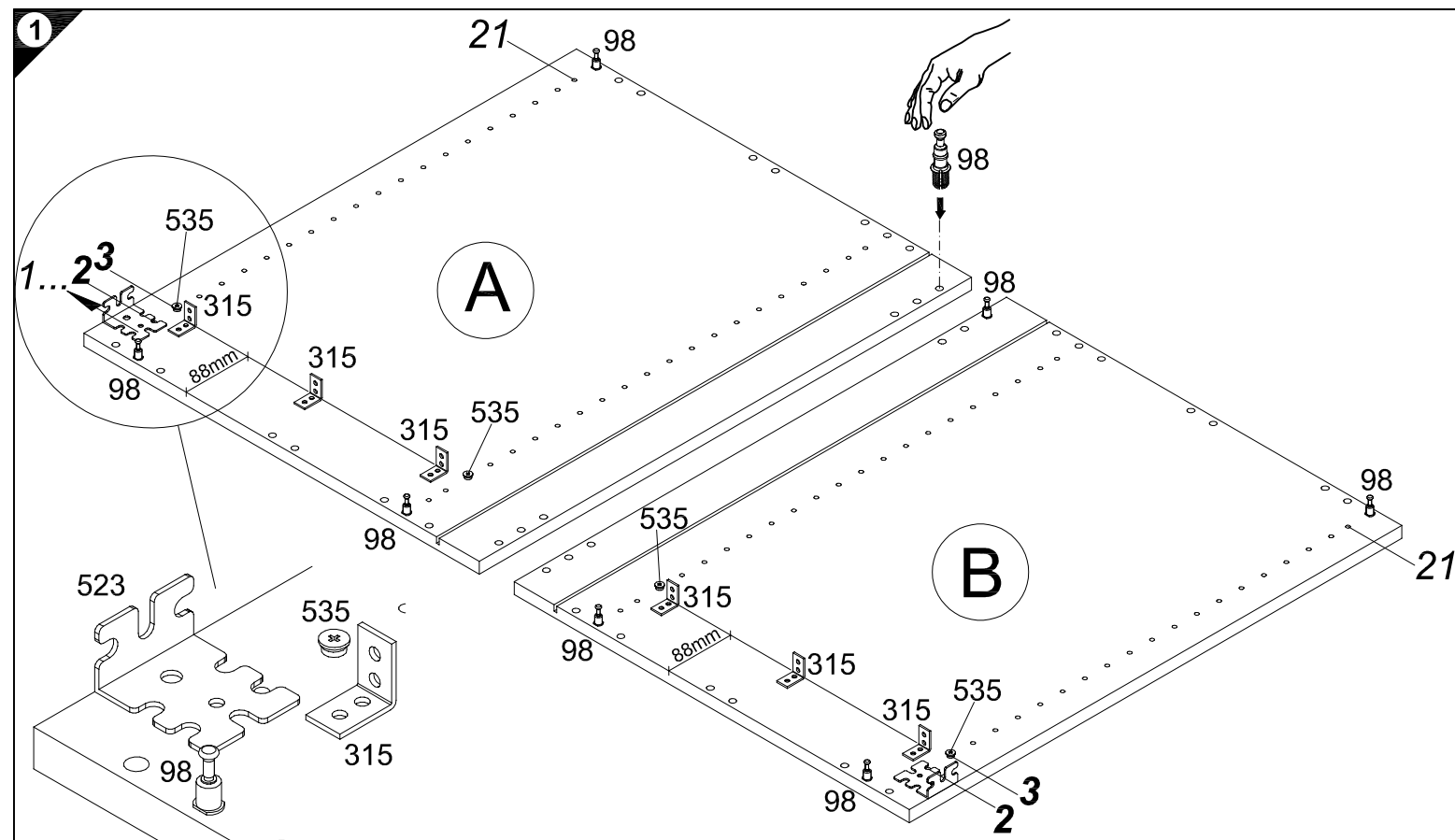
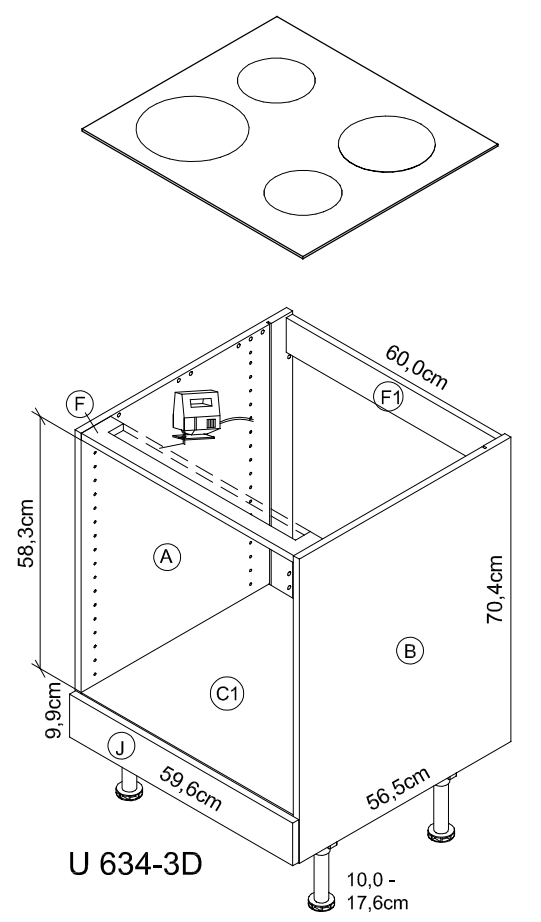
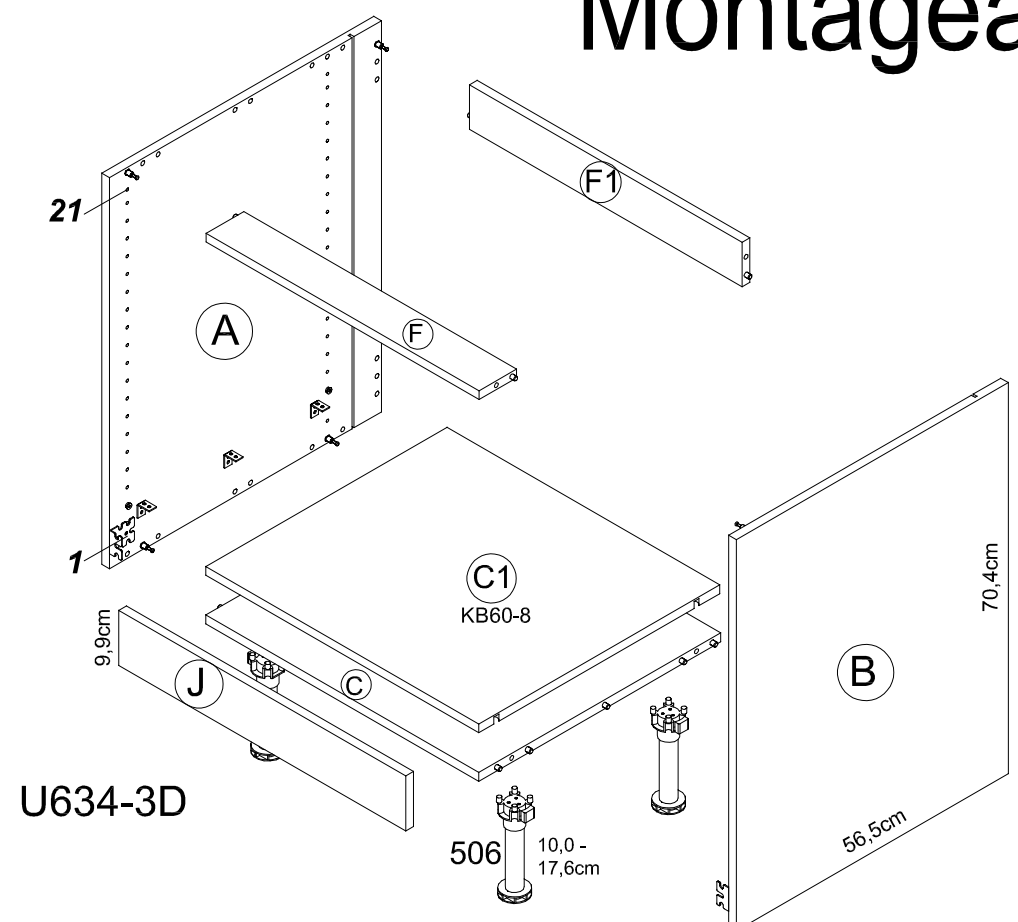

Ersatzteile/Spare parts/pièces de rechange/Reserveonderdelen/Piezas de recambio/Ricambi/Запасные части/Części zamienne/pótalkatrészek/Náhradní části/Nadomestni deli/varaosat/reservdelar/náhradné diely/Utilizați piese de schimb/Yedek parçalar

60cm U634-3D | (A)E941021 (B)E941021 (C)E951223 (C1)E950223 (F)E942973 (F1)E952973 (J)E940560

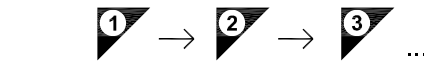
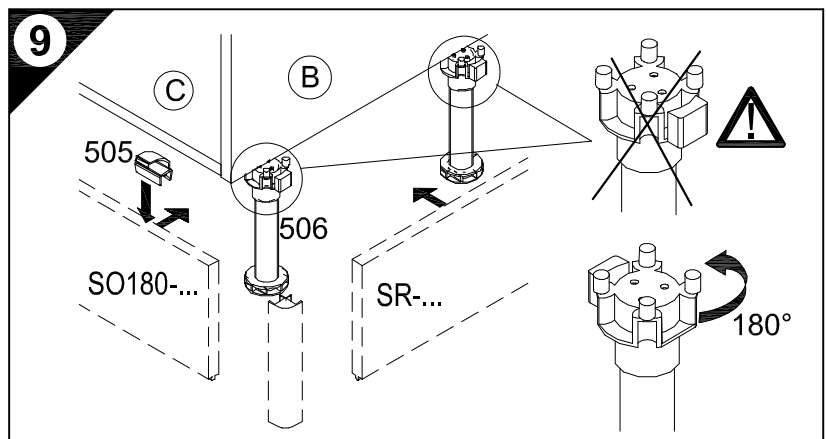
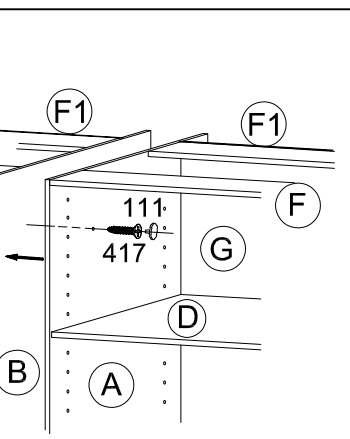
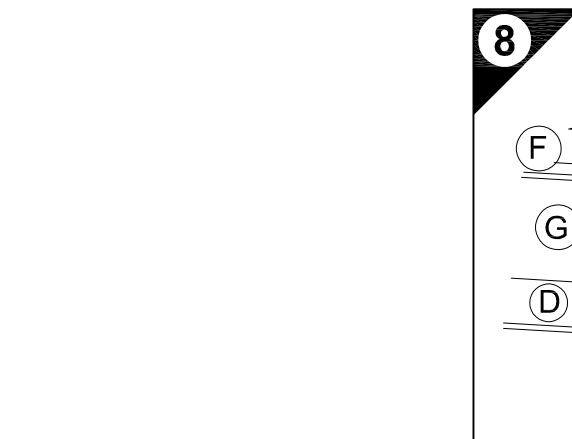
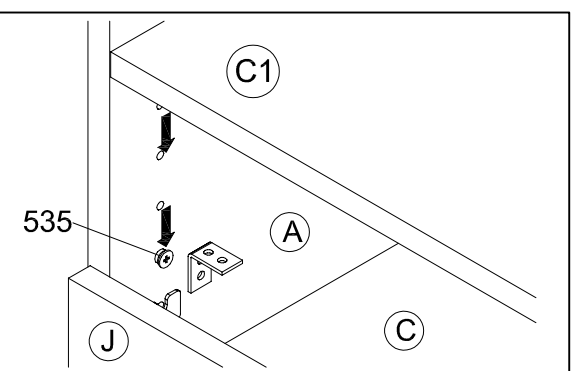
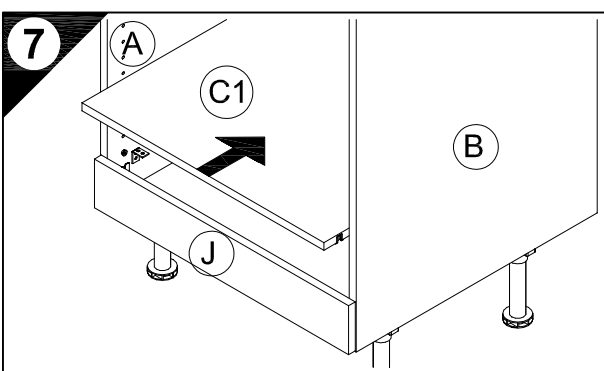
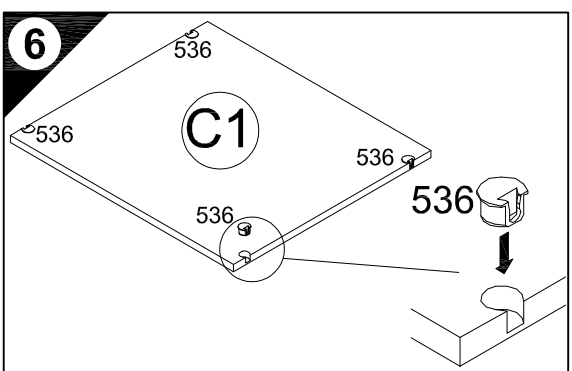
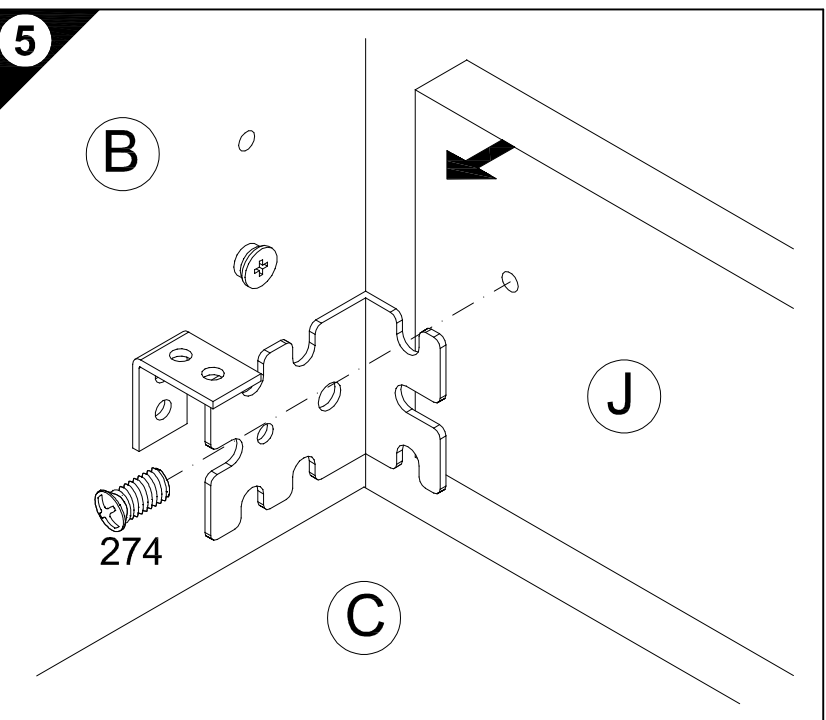
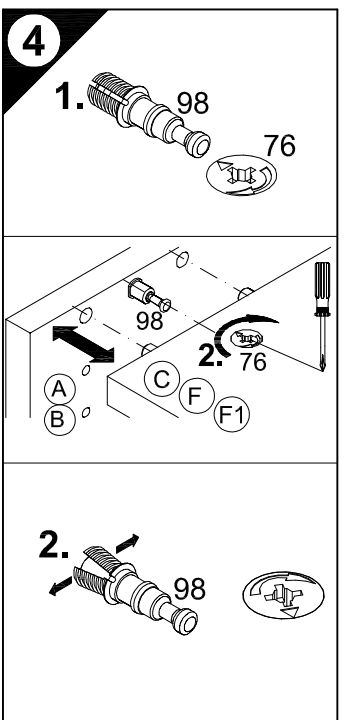
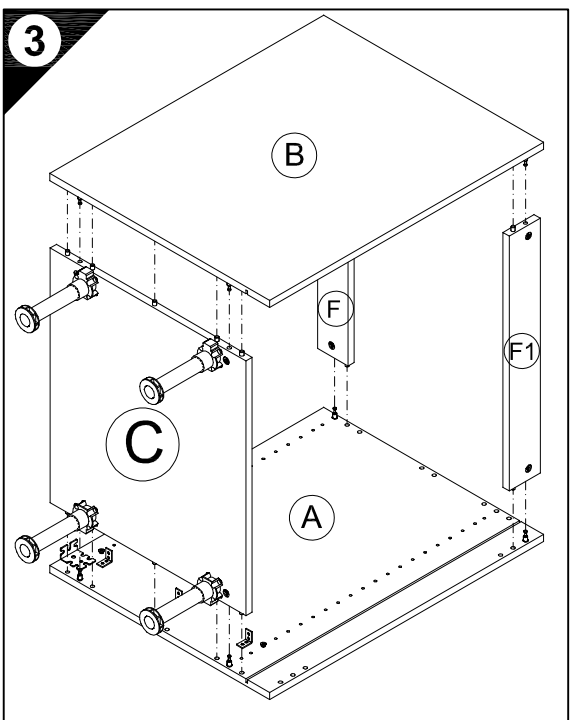
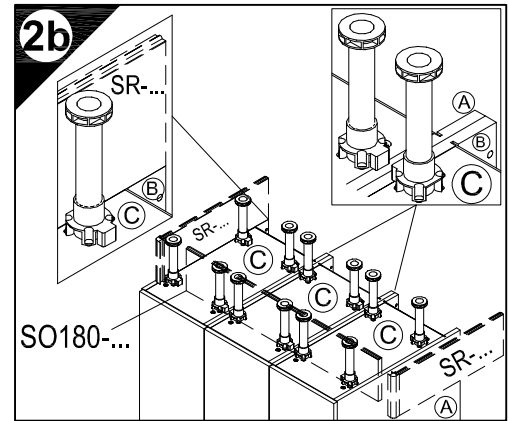
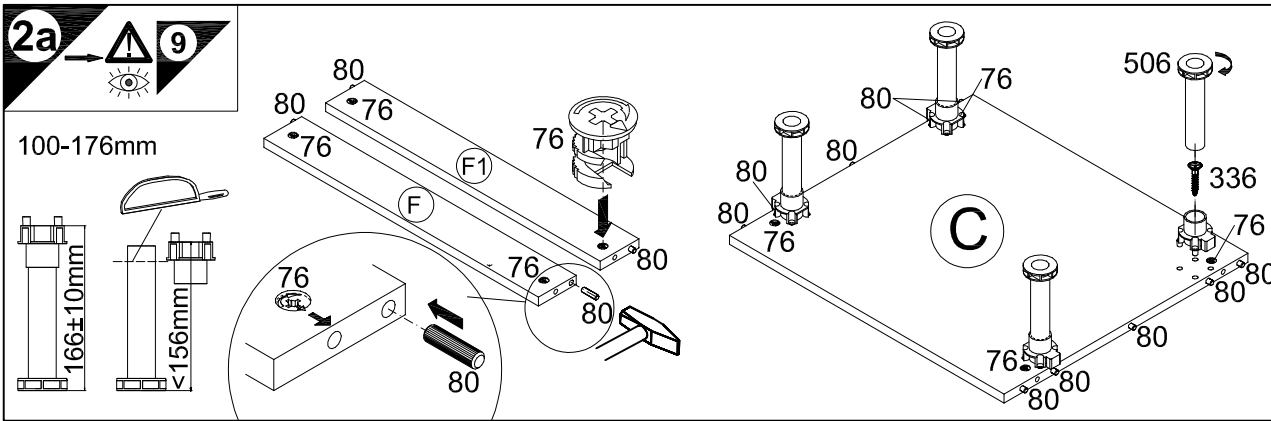

- 8x Nr.76
- 14x Ø8x30 Nr.80
- 2x Nr.506
- 4x 4x15 Nr.336
- 2x WS-8 6,3x13 Nr.274
- 4x KB60-8 Nr.536
- 2x 4,5x30 Nr.417
- 2x Nr.111
- 1x Nr.505

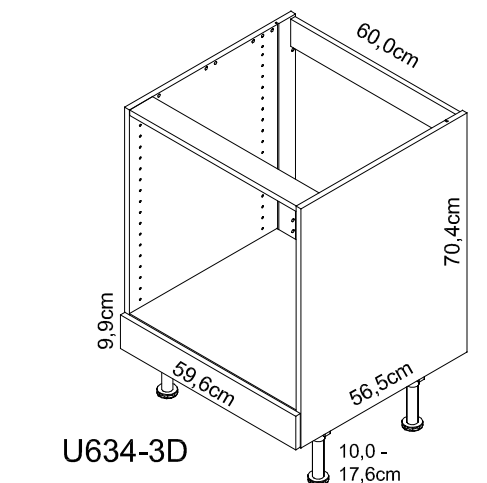

U634-3D



E 948031

Als Zubehör erhältlich
Available as an accessory
Disponibile en accessoire
Verkrijgbaar als accessoire
Se puede obtener como accesorio
Disponibile come accessorio
продаётся как принадлежность
Dostępna jako dodatkowe wyposażenie
Tartozéként kapható
k dodání jako příslušenství
Dobavljivo kot dodatna oprema
Lisävaruste
Kan levereras som tillbehör
Dostupné ako príslušenstvo
Disponibil ca accesoriu
Aksesuar olarak temin alınabilir

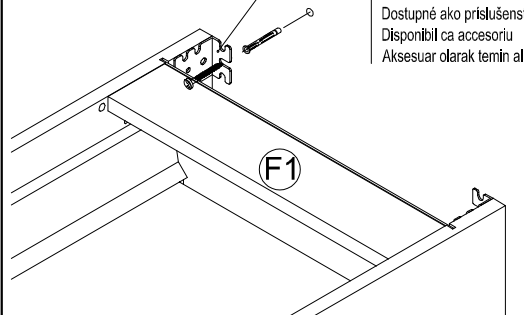

- D Die äußeren Schränke von miteinander zu einer Reihe verbundenen beliebigen Anzahl von Unterschränken, sowie einzeln stehende Unterschränke müssen mit Wandbefestigungswinkeln versehen werden.
- GB The outer cabinets must be fitted with wall mounting brackets if a row of any number of base units or individual base units are to be connected together.
- F Les armoires extérieures de tous meubles bas montés en ligne doivent être munies d'équerres de fixation murale. Il en va de même pour les meubles bas indépendants.
- NL De buitenste kasten van met elkaar tot een rij verbonden willekeurig aantal onderkasten, evenals apart staande onderkasten, moeten van wandbevestigingsbeugels worden voorzien.
- E Los armarios inferiores de los extremos, de una línea de módulos inferiores cuantos se deseen, deberán ser fijados a la pared con escuadras de fijación mural, así como los armarios inferiores que se monten aislados de forma independiente.
- I I mobili esterni al pari dei lavabi sparsi devono essere dotati di staffe di fissaggio a muro, se un numero qualsiasi di sottolavabi viene collegato l'uno con l'altro in una fila.
- RUS Если несколько напольных шкафов соединено вместе в единую секцию, то крайние шкафы следует привинтить к стене уголками. Отдельно стоящие напольные шкафы также следует крепить к стене уголками.
- PL Jeżeli dolne szafki połączone są ze sobą w szereg, to w uchwyt ścienny należy wyposażyć szafki zewnętrzne. Pojedyncze, wolnostojące dolne szafki, również należy wyposażyć w uchwyty.
- H A tetszőleges számú, egymáshoz rögzített alsó szekrényekből álló sor szélső szekrényeit, valamint a különálló alsó szekrényeket fal rögzítő profillal kell ellátni.
- CZ Ke stěně je nutno úhelníkem připevnit samostatně stojící skříňky a vnější skříňky, pokud jsou spolu s dalšími skříňkami spojeny v jedné řadě.
- SLO Zunanje omare se morajo pričvrstiti s pritrdilnimi zidnimi kotniki, kadar se povezujejo v eno linijo s poljubnim številom spodnjih omarič. Prav tako, se morajo prostostoječe spodnje omare, pričvrstiti s pritrdilnimi zidnimi kotniki.
- FIN Allkaapelsta muodostuvan kaapilrivin ulomat kaapit on varustettava seinäänkiinnityskulmilla, samoin kuin yksittäiskaapitkin.
- S De yttre skåpen måste förses med väggfästevinkel när ett valfritt antal underskåp förbinds till en rad. Även separat stående underskåp måste förses med väggfästevinkel.
- SK Na vonkajšie skrinky lubovného počtu spodných skriniek spojených do jedného radu, ako aj na samostatne stojace spodné skrinky je potrebné namontovať nástenný uholník.
- RO Părțile exterioare ale dulapurilor inferioare, indiferent de numărul lor, care sunt legate între ele într-un șir, precum și dulapurile inferioare individuale trebuie prevăzute cu comiere pentru fixarea de perete.
- TR Bir hat halinde birbirine bağlanmış olan çeşitli sayıdaki alt dolapların dış bölümünde kalan dolaplar, tek başına duran alt dolaplar, duvar sabitleme köşebentleri ile duvara bağlanmalıdır.

**OPTI
FIT**

JAKA-BKL GmbH
Jaka Straße 3
D-32351 Stemwede-Wehdem

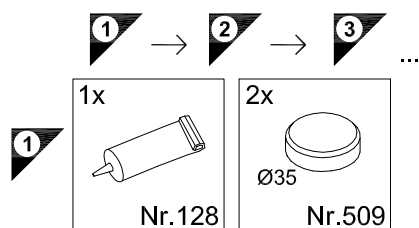
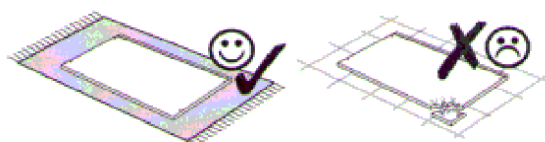
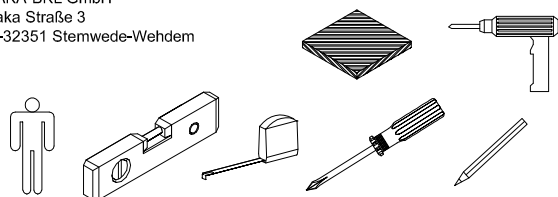

Service-Hotline
01805-678101
0,14€ pro Min.

++49 für Österreich
Auslandstarif pro Min.
service@jaka-bkl.de
voor Nederland en België
00800-40119350
benelux@jaka-bkl.de

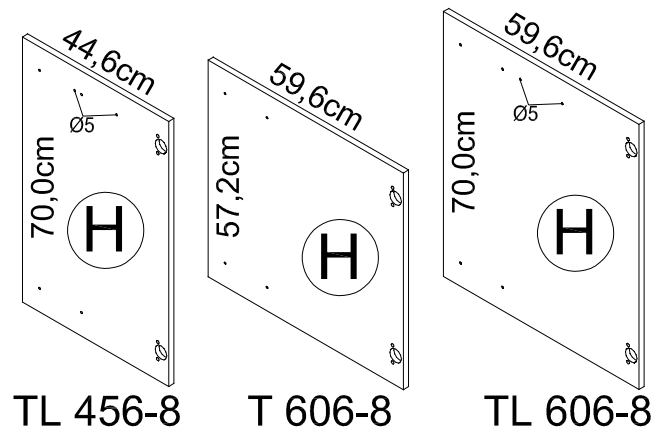

Montageanleitung

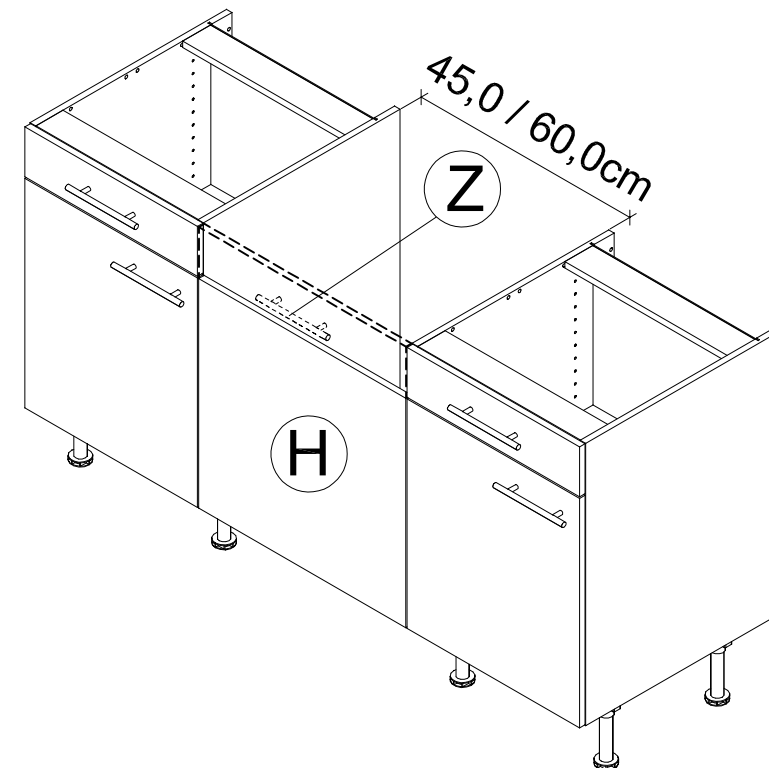
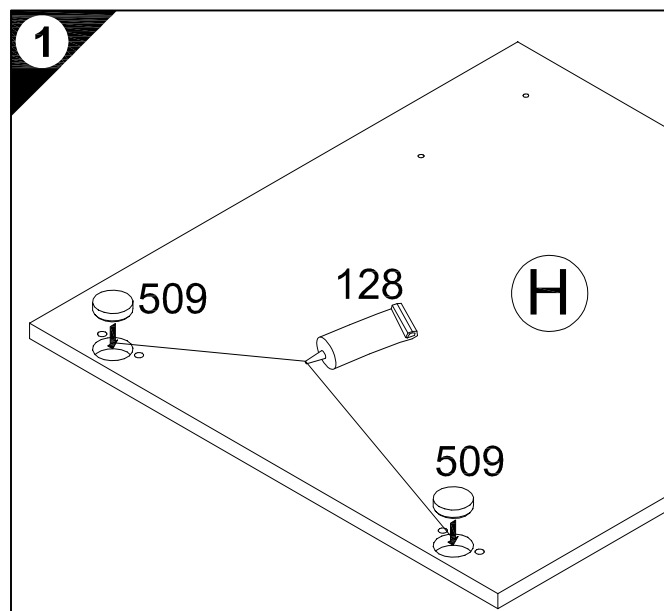
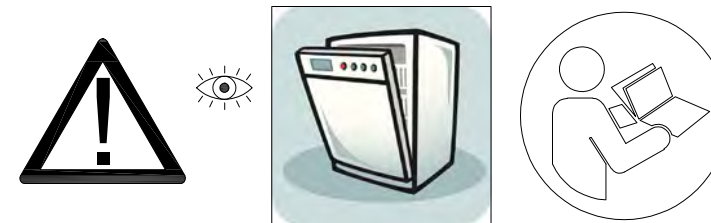

Ersatzteile/Spare parts/pièces de rechange/Reserveonderdelen/Piezas de recambio/Ricambi/Запасные части/Części zamienne/
pótalkatrészek/Náhradní části/Nadomestni deli/varaosat/reservdelar/náhradné diely/Utilizați piese de schimb/Yedek parçalar

TL 456-8	H E940620	Z E447100
T 606-8	H E940611	
TL 606-8	H E940621	Z E447100



2

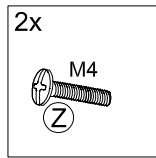

TL456-8
TL606-8

2

TL456-8
TL606-8

- D Holzunterlage verwenden!
Front andrücken, scharfen Bohrer verwenden
und mit wenig Druck durchbohren!
- GB Use a wooden base!
Press front down, use sharp drill bit
and, by applying slight pressure, drill a hole
- F Utiliser un support en bois !
Appuyer sur la façade, utiliser un foret bien affûté
et percer en appliquant une faible pression !
- NL Houten onderlegger gebruiken!
Druk het front aan, gebruik een scherpe boor
en oefen bij het boren weinig druk uit!
- E ¡Utilizar una base de madera!
¡Presionar el frente, utilizar una broca afilada
y taladrar con poca presión!
- I Utilizzare una base di legno! Appoggiare la facciata,
utilizzare una punta di trapano affilata
e trapanare esercitando solo una leggera pressione!
- RUS Использовать деревянную подложку!
Прижать фасад, использовать острое сверло
и просверлить с незначительным давлением!
- PL Używać podkładkę z drewna!
Docisnąć front, użyć ostrygo wiertła
i przewiercić, używając małej siły nacisku!
- H Alkalmazzon fa alátétet!
Nyomja le az előlapot, használjon éles fúrót,
és kis nyomással fúrja át!
- CZ Použijte dřevný podklad!
Přitlačte čelo, použijte ostrý vrták
a provrtejte pomocí malého tlaku!
- SLO Uporabite leseno podlago!
Pritisnite ličnico ter z ostrim svedrom
in z majhnim pritiskom izvrtaite luknjo!
- FIN Käytä puualustaa!
Paina etulevy paikoilleen, käytä terävää
poranterää ja poraa reikä vain kevyesti painamalla!
- S Använd ett träunderlag!
Tryck fronten mot underlaget, använd vass borrh
och borra igenom med ett lätt tryck!
- SK Použite drevený podklad!!
Přitlačte front, použite ostrý vrták a prevrtajte miernym tlakom!
- RO suport de lemn! Împingeți frontul, utilizați un burghiu
ascuțit și perforați exercitând doar o presiune redusă!
- TR Ahşap taban kullanın!
Önden bastırın, keskin matkap ucu kullanın ve az basınç
uygulayarak delin!

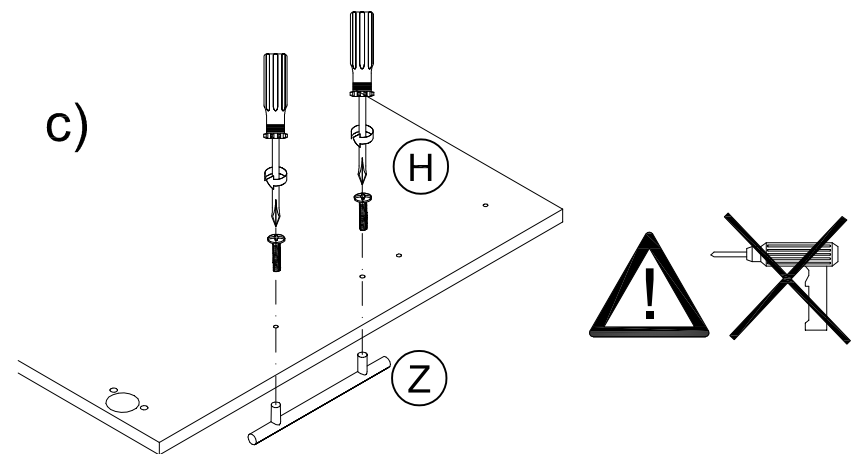
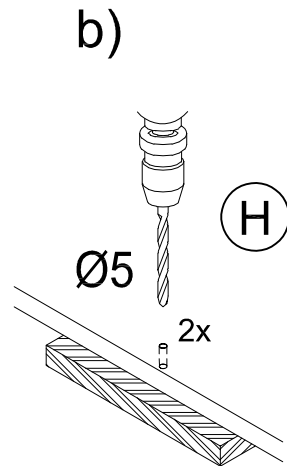
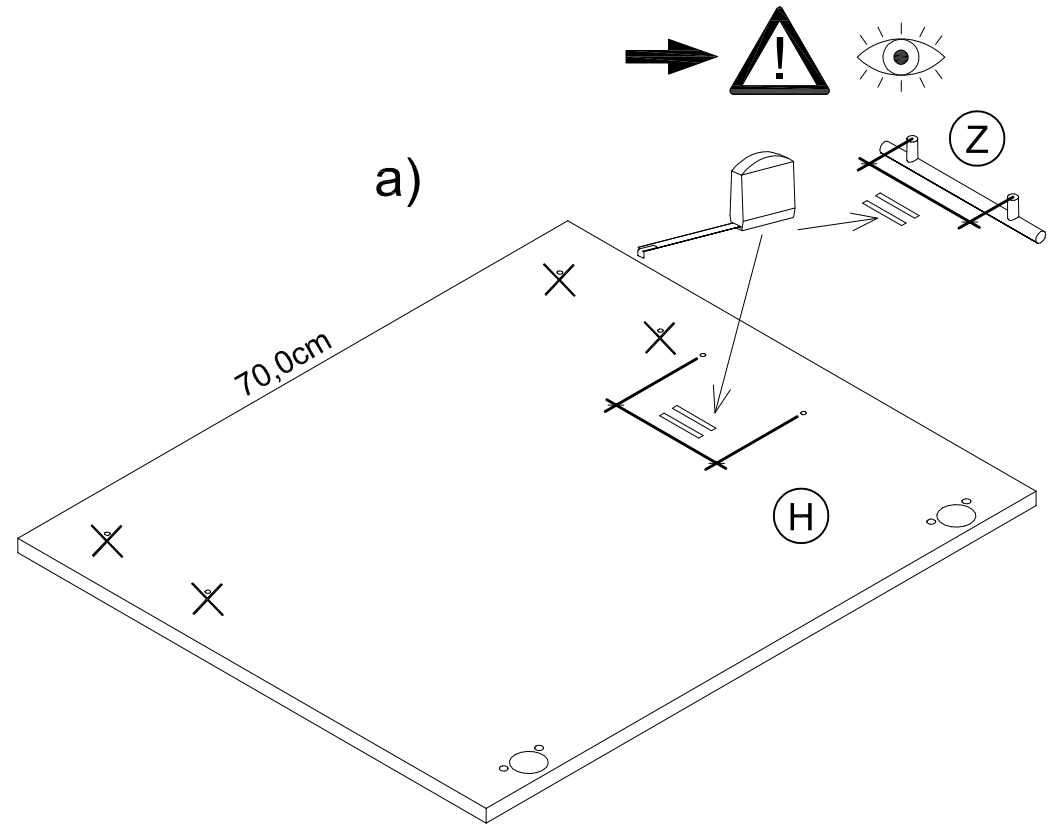

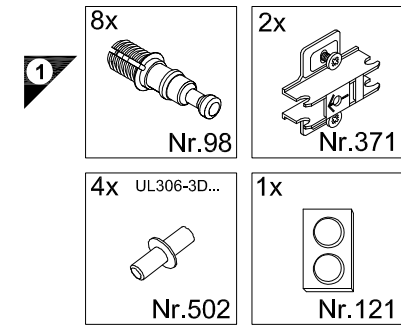
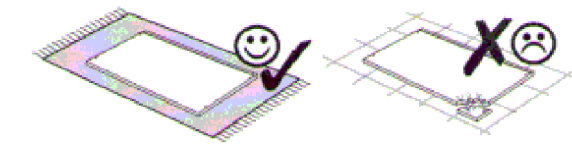
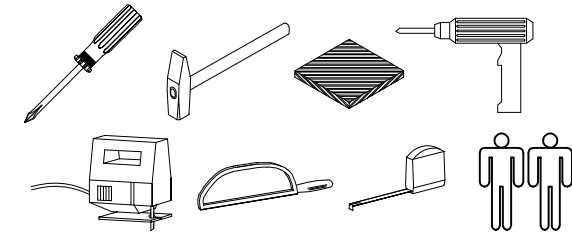

Service-Hotline
01805-678101
0,14€ pro Minute
+49 für Österreich
Auslandstarif pro Minute
service@jaka-bkl.de
voor Nederland en België
00800-40119350
benelux@jaka-bkl.de

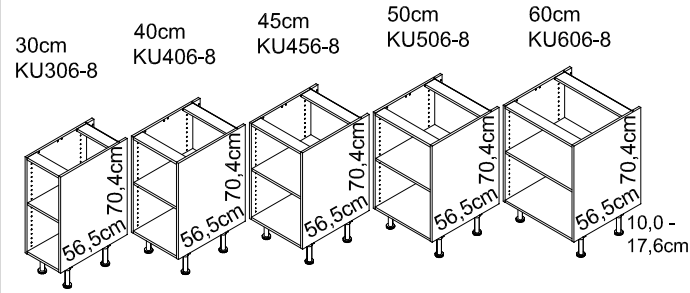

UL 306...606-3D

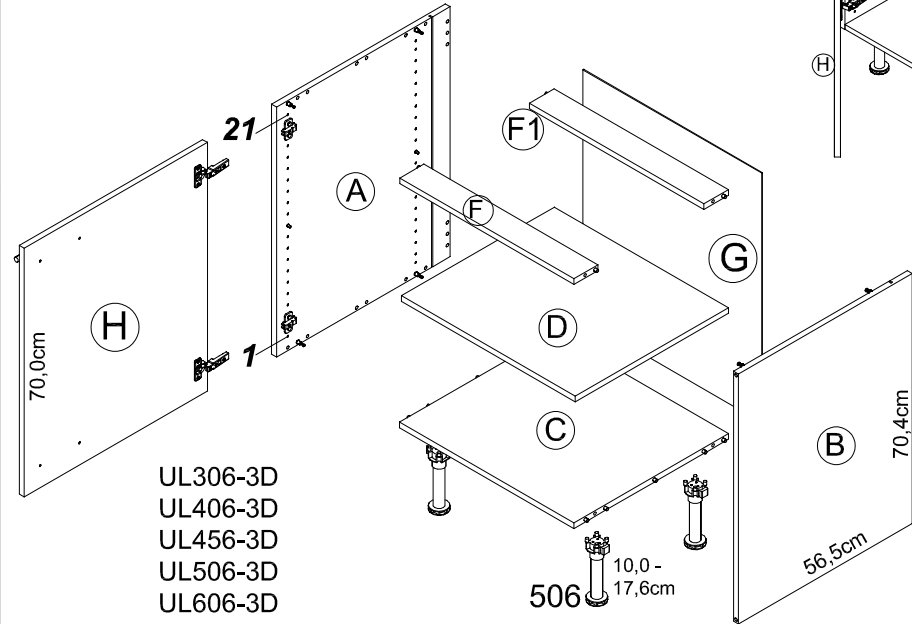
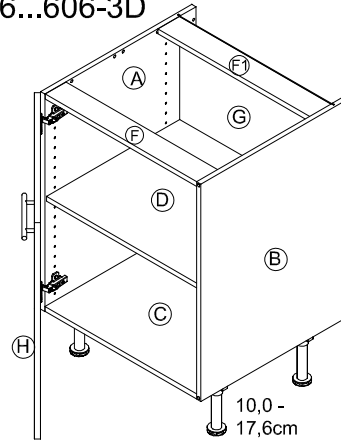

UL306-3D
UL406-3D
UL456-3D
UL506-3D
UL606-3D

Montageanleitung

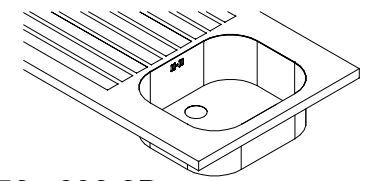

SPL 456...606-3D

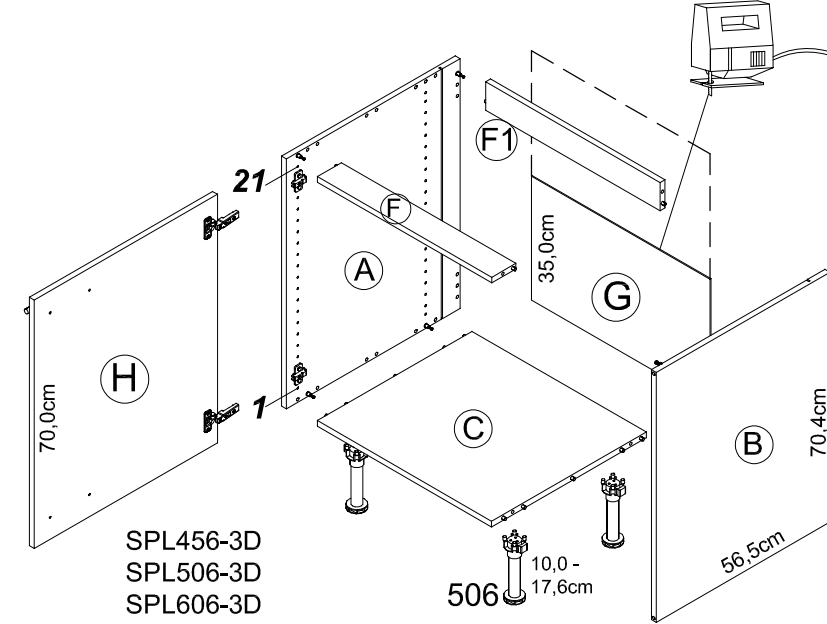
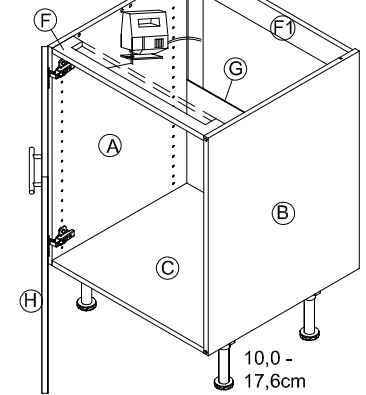

SPL456-3D
SPL506-3D
SPL606-3D

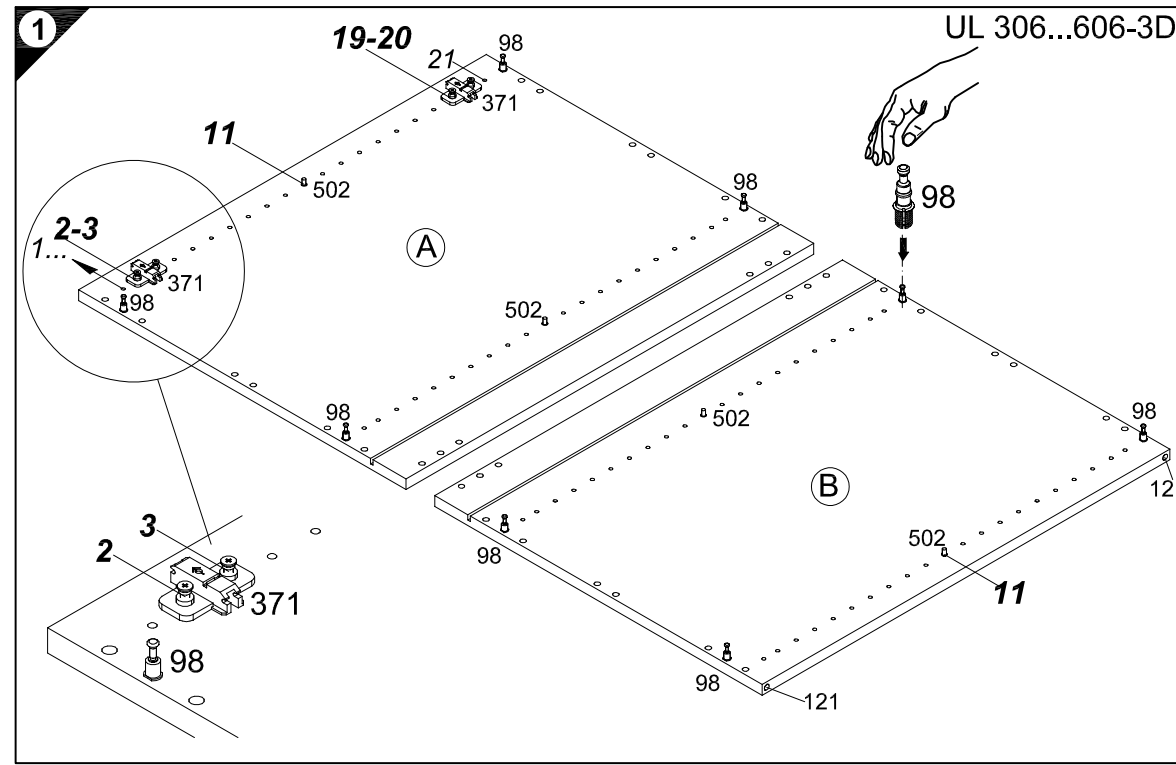

UL 306...606-3D

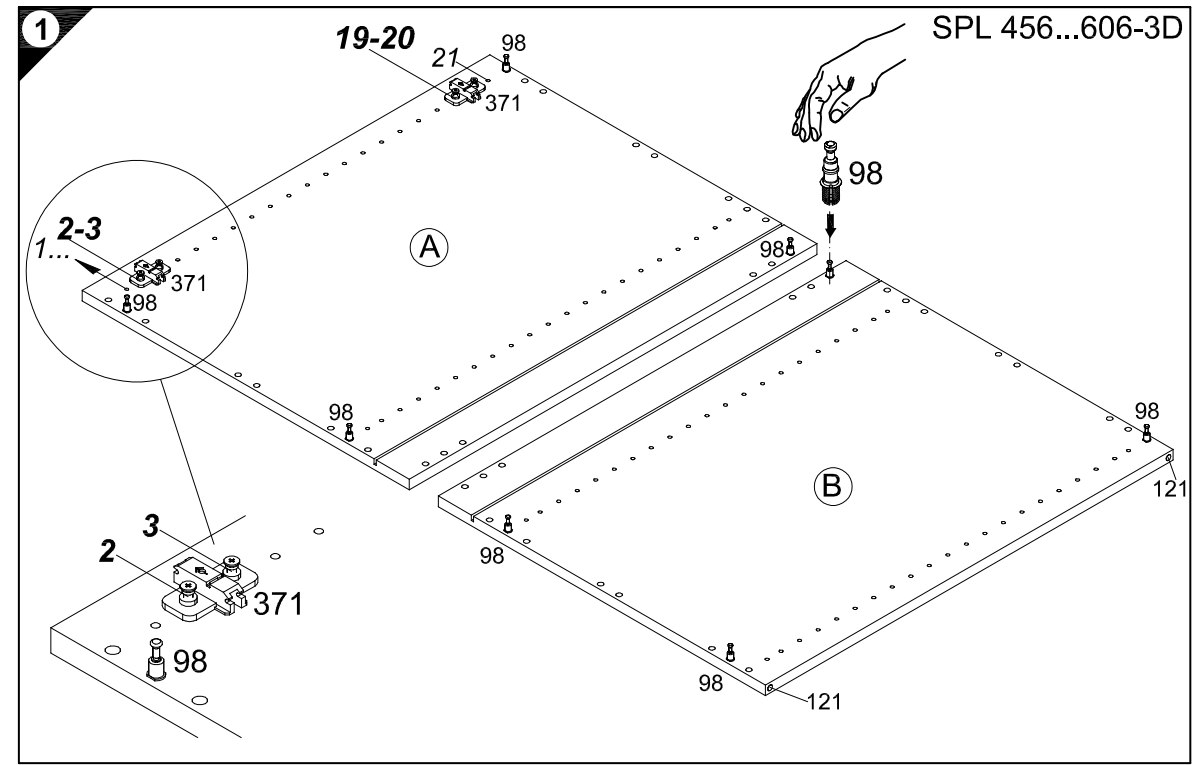

SPL 456...606-3D

Ersatzteile/Spare parts/pièces de rechange/Reserveonderdelen/Piezas de recambio/Ricambi/Запасные части/Części zamienne/pótalkatrészek/Náhradní části/Nadomestni deli/varaosat/reservdelar/náhradné diely/Utilizați piese de schimb/Yedek parçalar

30cm UL 306-3D	(A) E941021	(B) E941021	(C) E951216	(D) E950306	(F) E942976	(F1) E952976	(G) E970006	(H) E940624
40cm UL 406-3D	(A) E941021	(B) E941021	(C) E951215	(D) E950305	(F) E942975	(F1) E952975	(G) E970010	(H) E940623
45cm UL 456-3D	(A) E941021	(B) E941021	(C) E951227	(D) E950308	(F) E942977	(F1) E952977	(G) E970070	(H) E940620
50cm UL 506-3D	(A) E941021	(B) E941021	(C) E951224	(D) E950304	(F) E942974	(F1) E952974	(G) E970117	(H) E940622
60cm UL 606-3D	(A) E941021	(B) E941021	(C) E951223	(D) E950303	(F) E942973	(F1) E952973	(G) E970116	(H) E940621
45cm SPL 456-3D	(A) E941021	(B) E941021	(C) E951227	(F) E942977	(F1) E952977	(G) E970070	(H) E940620	
50cm SPL 506-3D	(A) E941021	(B) E941021	(C) E951224	(F) E942974	(F1) E952974	(G) E970117	(H) E940622	
60cm SPL 606-3D	(A) E941021	(B) E941021	(C) E951223	(F) E942973	(F1) E952973	(G) E970116	(H) E940621	

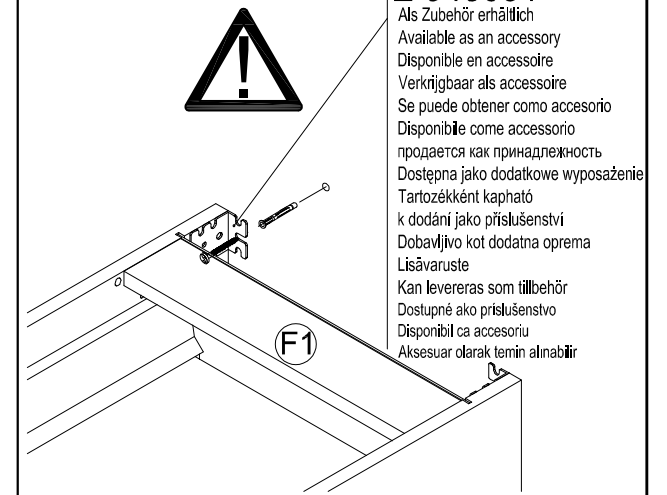
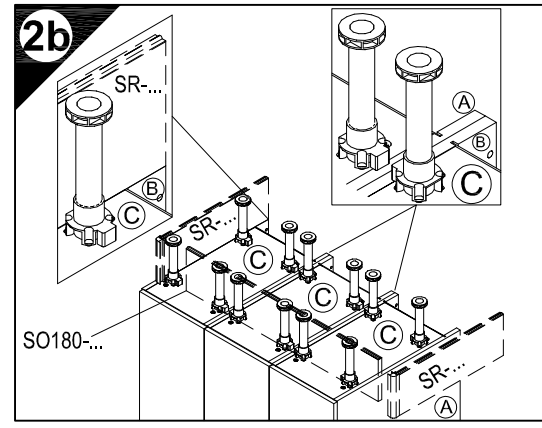
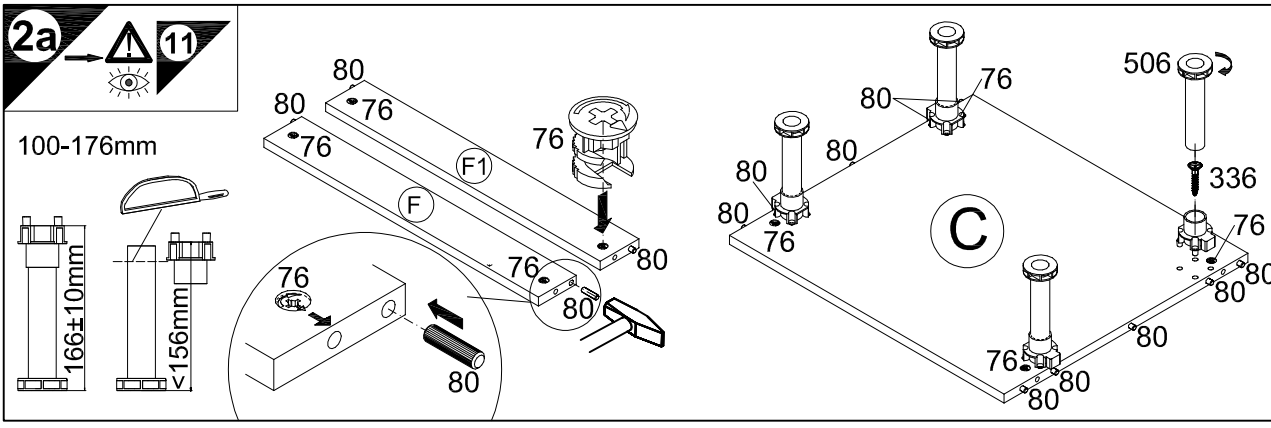
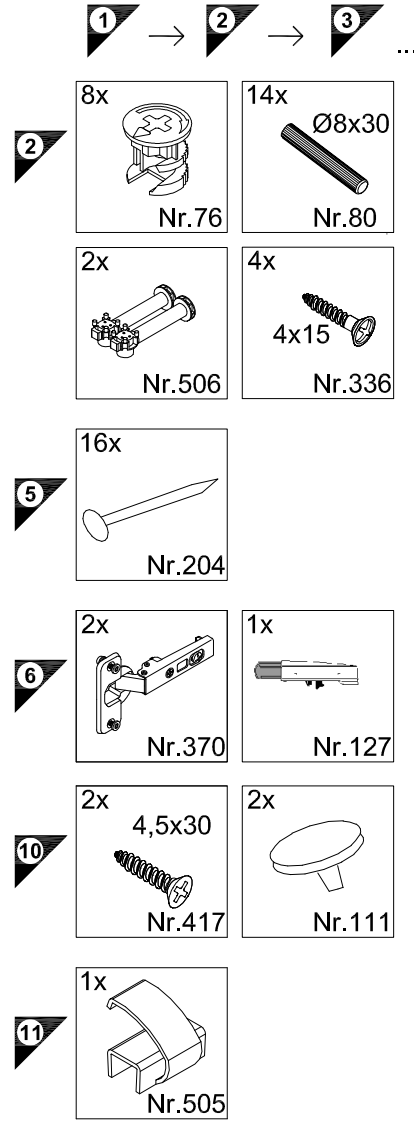

E 948031
 Als Zubehör erhältlich
 Available as an accessory
 Disponible en accessoire
 Verkrijgbaar als accessoire
 Se puede obtener como accesorio
 Disponibile come accessorio
 prodается как принадлежность
 Dostępna jako dodatkowe wyposażenie
 Tartozéként kapható
 k dodání jako příslušenství
 Dobavljivo kot dodatna oprema
 Lisävaruste
 Kan levereras som tillbehör
 Dostupné ako príslušenstvo
 Disponibil ca accesoriu
 Aksesuar olarak temin alınabilir

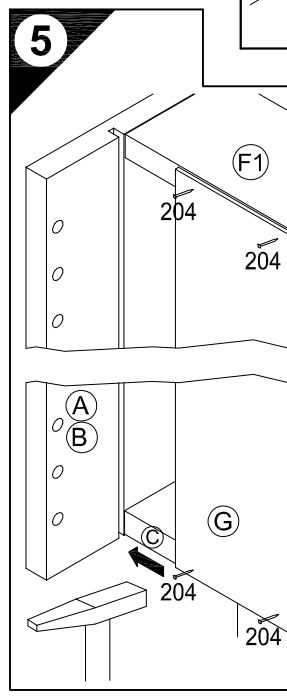
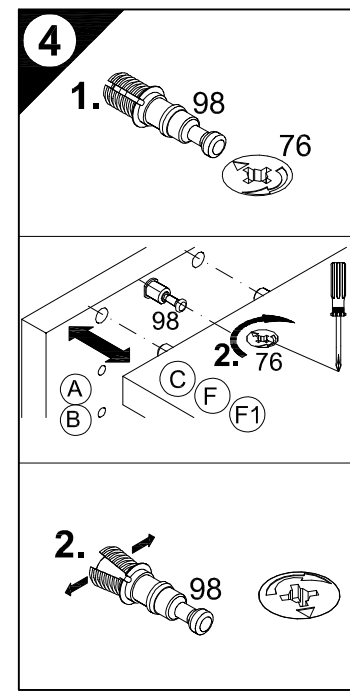
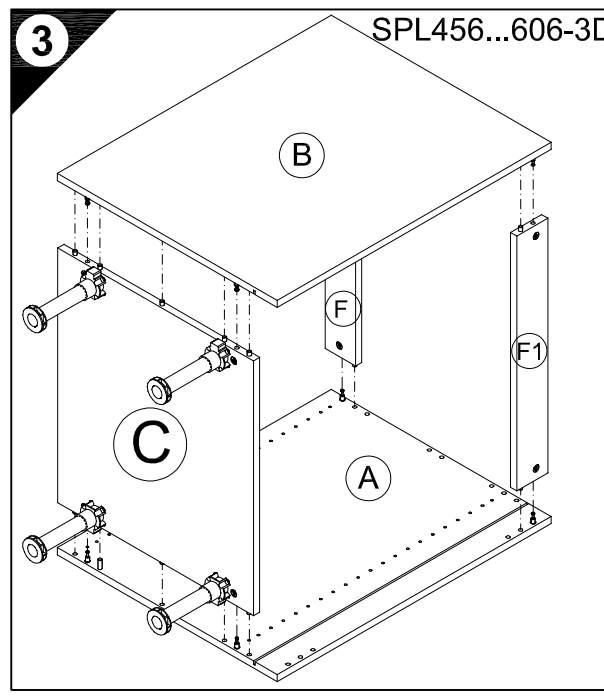
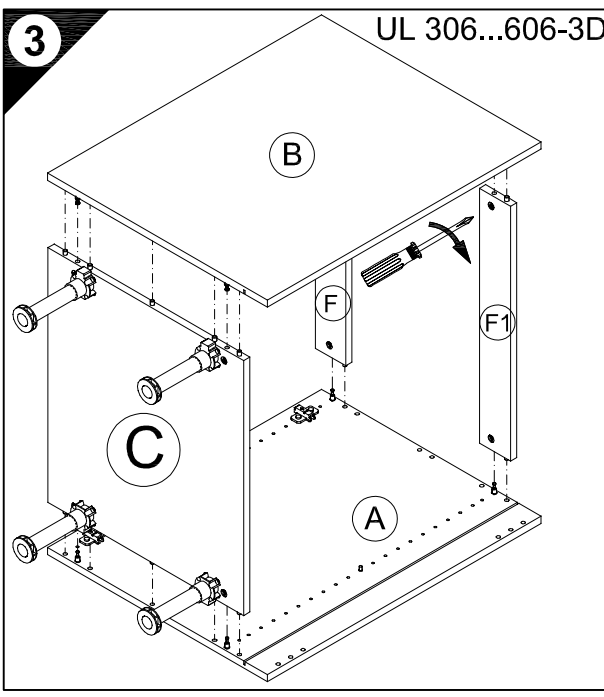

D Die äußeren Schränke von miteinander zu einer Zeile verbundenen beliebigen Anzahl von Unterschränken, sowie einzeln stehende Unterschränke müssen mit Wandbefestigungswinkeln versehen werden.
GB The outer cabinets must be fitted with wall mounting brackets if a row of any number of base units or individual base units are to be connected together.
F Les armoires extérieures de tous meubles bas montés en ligne doivent être munies d'équerres de fixation murale. Il en va de même pour les meubles bas indépendants.
NL De buitenste kasten van met elkaar tot een rij verbonden willekeurig aantal onderkasten, evenals apart staande onderkasten, moeten van wandbevestigingsbeugels worden voorzien.
E Los armarios inferiores de los extremos, de una línea de módulos inferiores cuantos se deseen, deberán ser fijados a la pared con escuadras de fijación mural, así como los armarios inferiores que se monten aislados de forma independiente.
I I mobili esternali al pari dei lavabi sparsi devono essere dotati di staffe di fissaggio a muro, se un numero qualsiasi di sottolavabi viene collegato l'uno con l'altro in una fila.
RUS Если несколько напольных шкафов соединено вместе в единую секцию, то крайние шкафы следует привинтить к стене уголками. Отдельно стоящие напольные шкафы также следует крепить к стене уголками.
PL Jeżeli dolne szafki połączone są ze sobą w szereg, to w uchwytach ściennie należy wyposażyć szafki zewnętrzne. Pojedyncze, wolnostojące dolne szafki, również należy wyposażyć w uchwyty.
H A tetszöleges számú, egymáshoz rögzített alsó szekrényekből álló sor szélső szekrényeit, valamint a különálló alsó szekrényeket fali rögzítő profillal kell ellátni.
CZ Ke stěně je nutno úhelníkem připevnit samostatně stojící skříňky a vnější skříňky, pokud jsou spolu s dalšími skříňkami spojeny v jedné řadě.
SLO Zunanje omare se morajo pričvrstiti s pritrilnimi zidnimi kotniki, kadar se povezujejo v eno linijo s poljubnim številom spodnjih omaric. Prav tako, se morajo prostostoječe spodnje omare, pričvrstiti s pritrilnimi zidnimi kotniki.
FIN Alikaapeista muodostuvan kaappirivin uloimmat kaapit on varustettava seinäänkiinnityskulmilla, samoin kuin yksittäiskaapitkin.
S De yttre skåpen måste försees med väggfästevinkel när ett valfritt antal underskåp förbinds till en rad. Även separat stående underskåp måste försees med väggfästevinkel.
SK Na vonkajšie skrinky ľubovoľného počtu spodných skriniek spojených do jedného radu, ako aj na samostatne stojace spodné skrinky je potrebné namontovať nástenný uholník.
RO Părțile exterioare ale dulapurilor inferioare, indiferent de numărul lor, care sunt legate între ele într-un șir, precum și dulapurile inferioare individuale trebuie prevăzute cu corniere pentru fixarea de perete.
TR Bir hat halinde birbirine bağlanmış olan çeşitli saydaki alt dolapların dış bölümünde kalan dolaplar, tek başına duran alt dolaplar, duvar sabitleme köşebentleri ile duvara bağlanmalıdır.

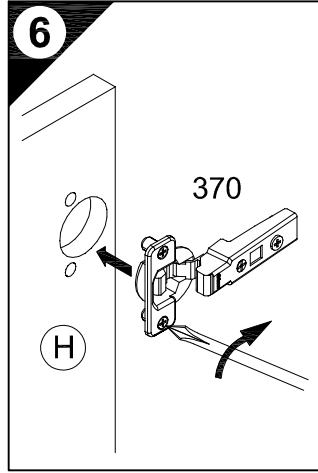

6
D Holzunterlage verwenden!
GB Front andrücken, scharfen Bohrer verwenden und mit wenig Druck durchbohren!
F Use a wooden base!
F Press front down, use sharp drill bit and, by applying slight pressure, drill a hole
F Utiliser un support en bois!
F Appuyer sur la façade, utiliser un foret bien affûté et percer en appliquant une faible pression!
NL Houten onderlegger gebruiken!
NL Druk het front aan, gebruik een scherpe boor en oefen bij het boren weinig druk uit!
E ¡Utilizar una base de madera!
E ¡Presionar el frente, utilizar una broca afilada y taladrar con poca presión!
I Utilizzare una base di legno!
I Appoggiare la facciata, utilizzare una punta di trapano affilata e trapanare esercitando solo una leggera pressione!
RUS Использовать деревянную подложку!
RUS Прижать фасад, использовать острое сверло и просверлить с незначительным давлением!
PL Używać podkładkę z drewna!
PL Docisnąć front, użyć ostrego wiertła i przewiercić, używając małej siły nacisku!

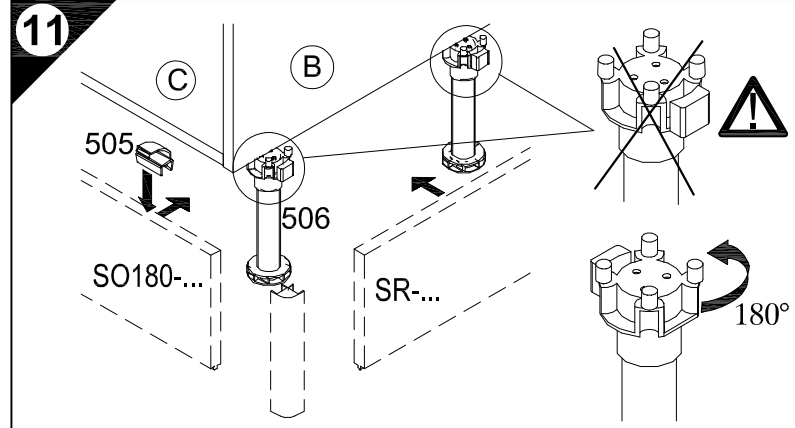
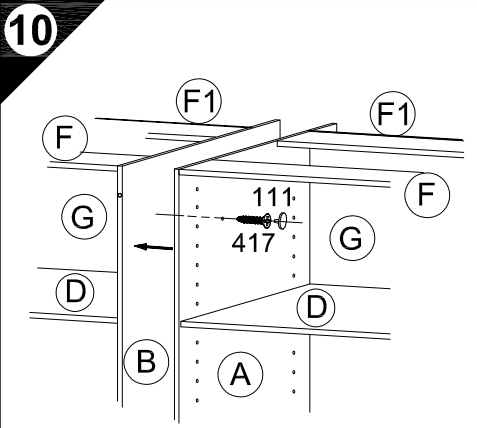
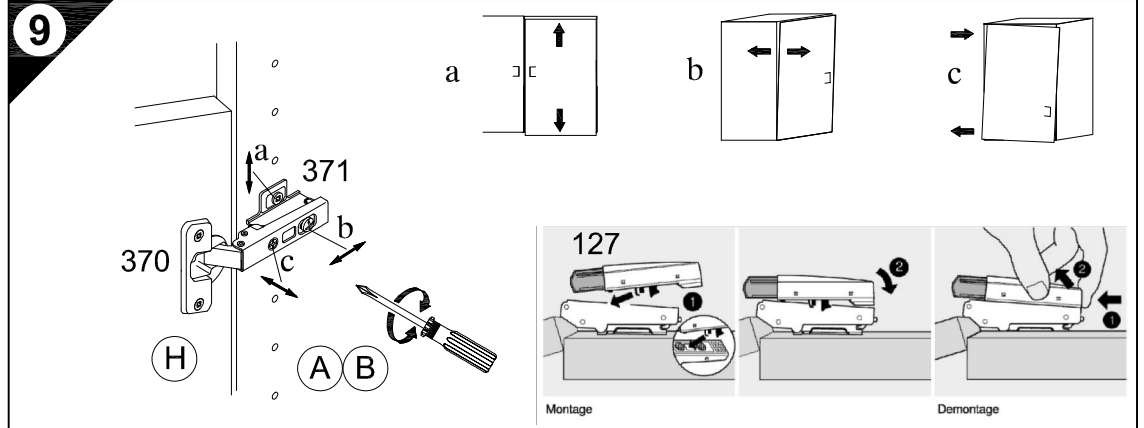
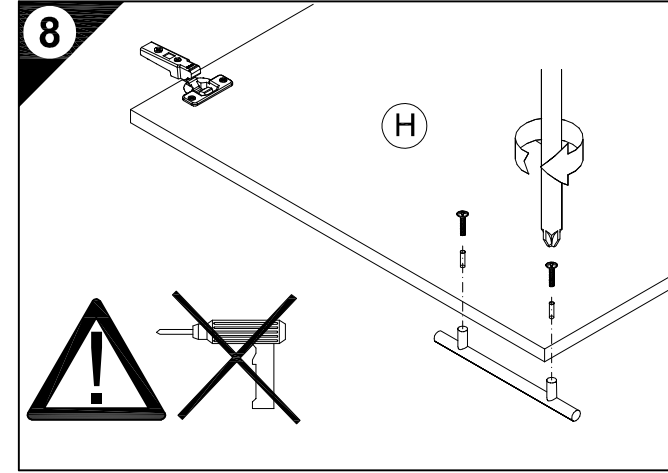
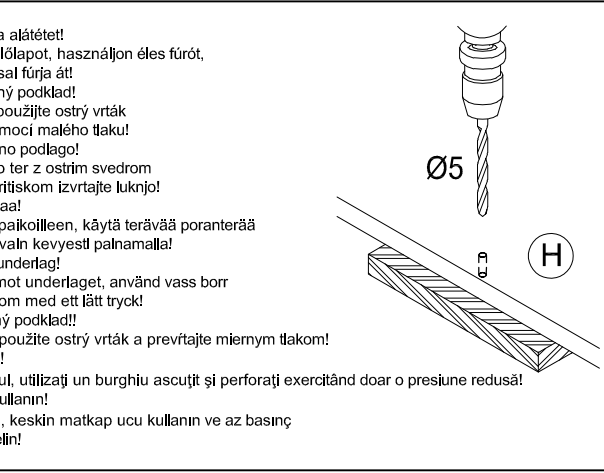



JAKA-BKL GmbH
Jaka Straße 3
D-32351 Sternweide-Wehden

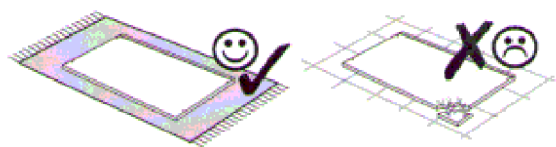
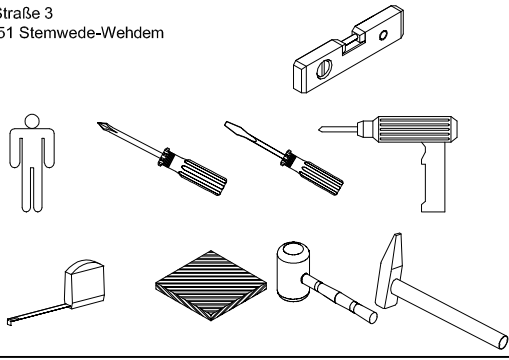

- 1** 8x Nr.98
- 2** 8x Nr.502
- 2** 8x Nr.76
- 2x Nr.371
- 1x Nr.121
- 16x Ø8x30 Nr.80

Service-Hotline
01805-678101
0,14€ pro Minute
++49 für Österreich
Auslandstarif pro Minute
service@jaka-bkl.de
voor Nederland en België
00800-40119350
benelux@jaka-bkl.de

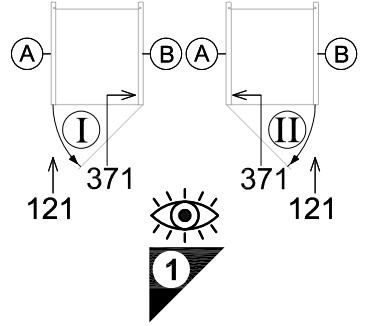
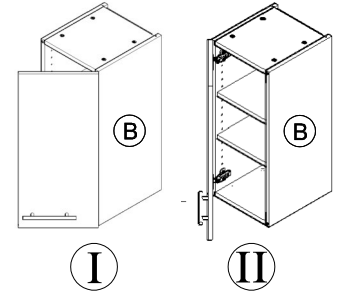
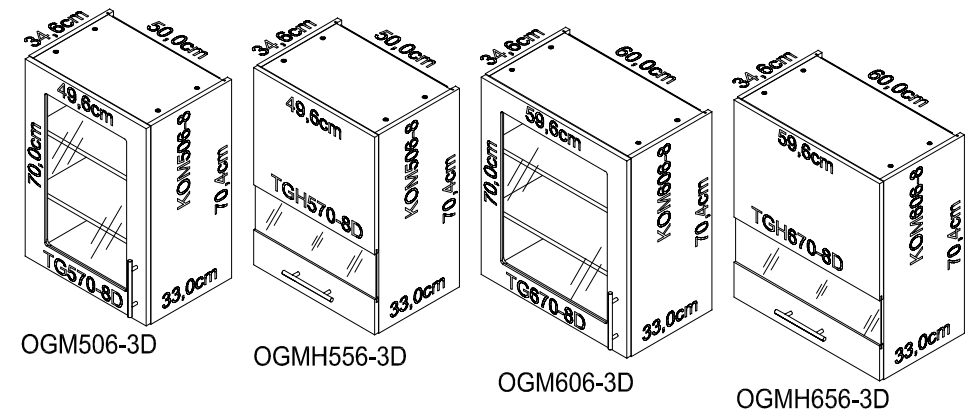
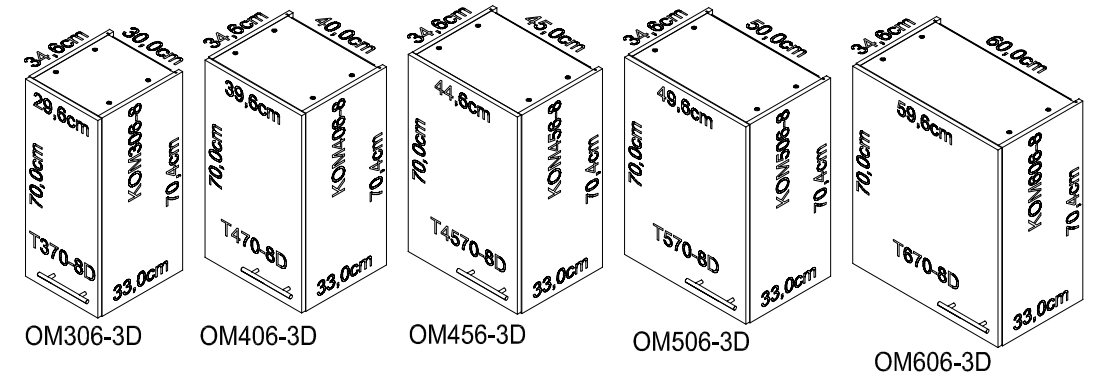

Montageanleitung

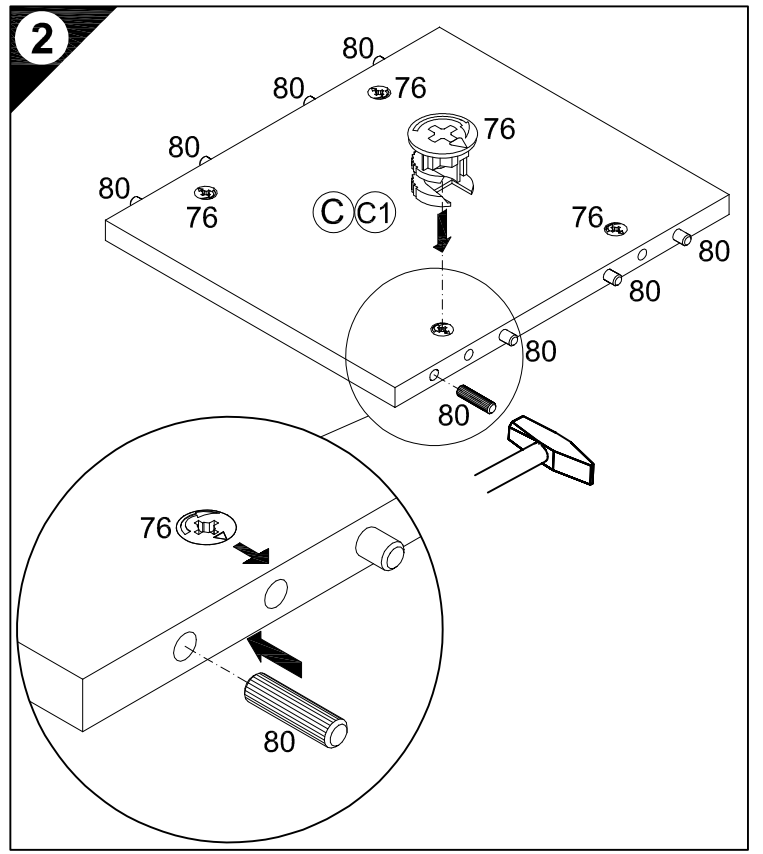
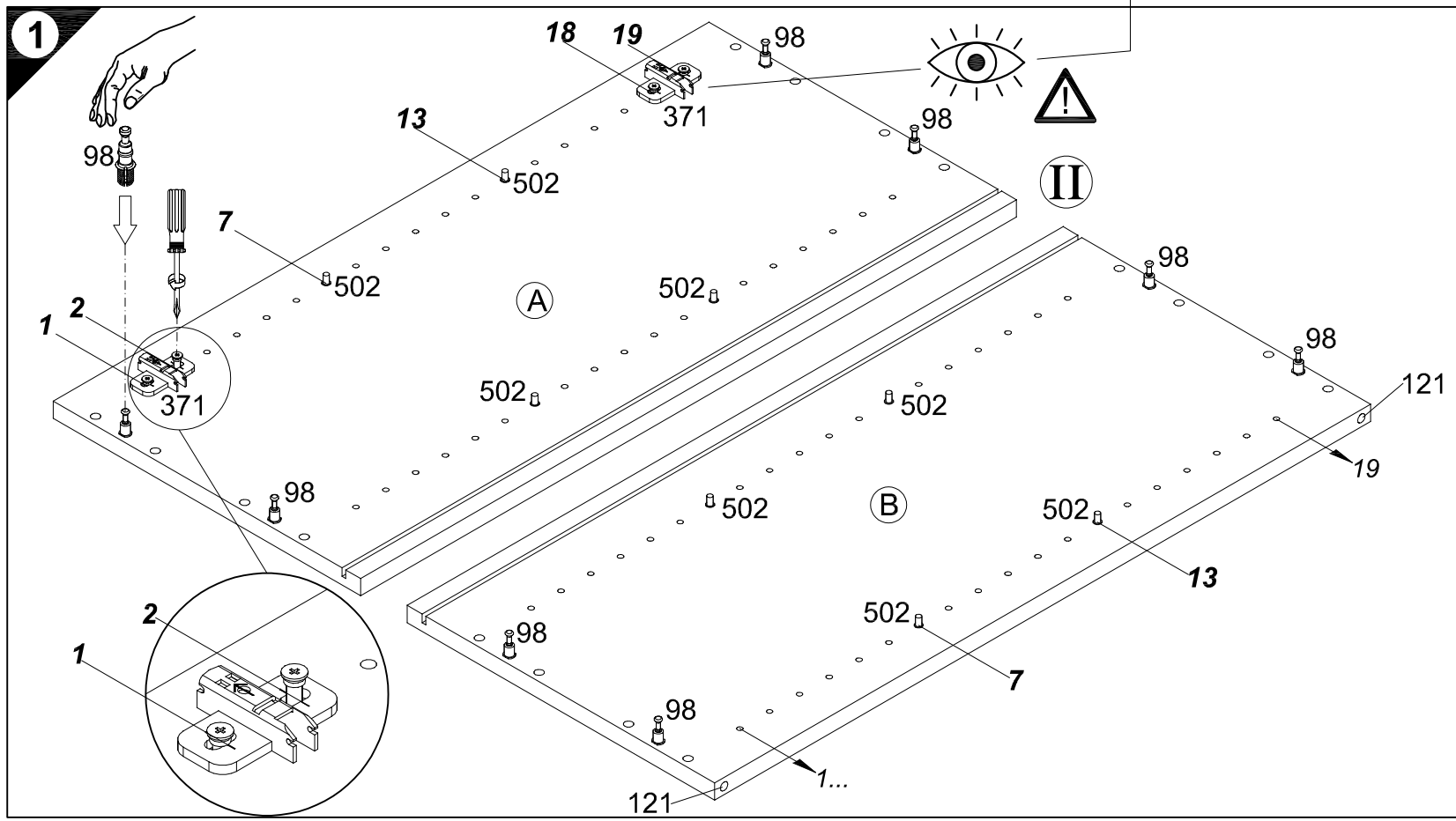
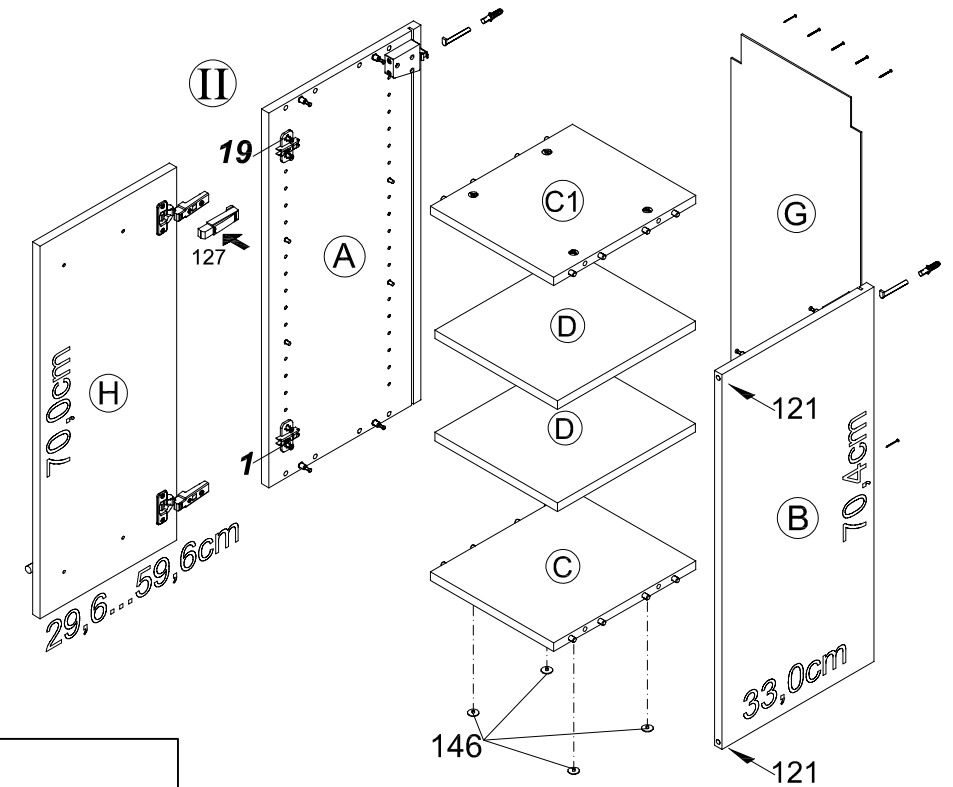

Ersatzteile/Spare parts/pièces de rechange/Reserveonderdelen/Piezas de recambio/Ricambi/Запасные части/Części zamiennie/pótkatrészek/Náhradní části/Nadomestni deli/varaosat/reservdelar/náhradné diely/Utilizați piese de schimb/Yedek parçalar

30cm OM306-3D	A E940037	B E940037	C E941236	C1 E941236	D E940336	G E970015	H E940624	50cm OGM506-3D	A E940037	B E940037	C E941234	C1 E941234	D E940334	G E970013	H E940646
40cm OM406-3D	A E940037	B E940037	C E941235	C1 E941235	D E940335	G E970014	H E940623	50cm OGMH556-3D	A E940037	B E940037	C E941234	C1 E941234	D E940334	G E970013	H E940648
45cm OM456-3D	A E940037	B E940037	C E941237	C1 E941237	D E940337	G E970055	H E940620	60cm OGM606-3D	A E940037	B E940037	C E941233	C1 E941233	D E940333	G E970012	H E940717
50cm OM506-3D	A E940037	B E940037	C E941234	C1 E941234	D E940334	G E970013	H E940622	60cm OGMH656-3D	A E940037	B E940037	C E941233	C1 E941233	D E940333	G E970012	H E940717
60cm OM606-3D	A E940037	B E940037	C E941233	C1 E941233	D E940333	G E970012	H E940621								

- 3** 4x Ø18/Ø4 Nr.146
- 4** 2x Nr.277 6x 4x30 Nr.164
- 5** 10x 1,4x25 Nr.204
- 7** 2x Nr.370 2x 445199 Nr.107
- 9** 1x 419153 Nr.127
- 10** 2x Ø8x40 Nr.70 2x Nr.69
- 11** 2x 4,5x30 Nr.417 2x Nr.111

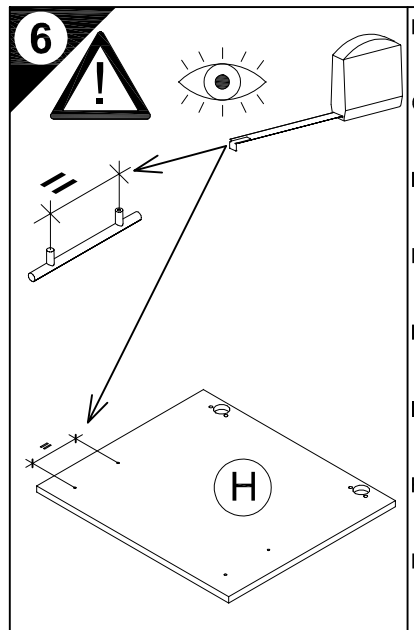
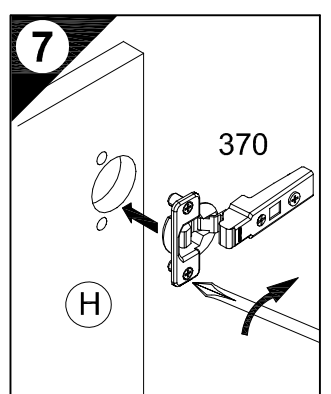
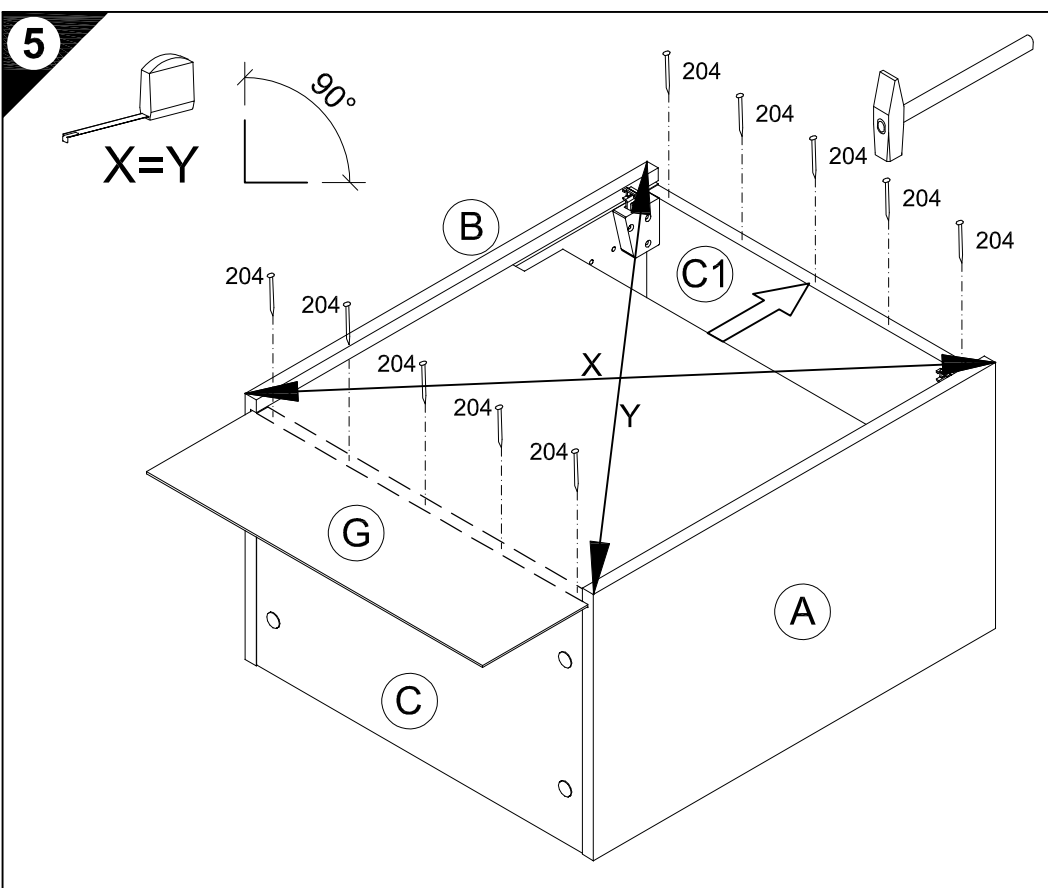
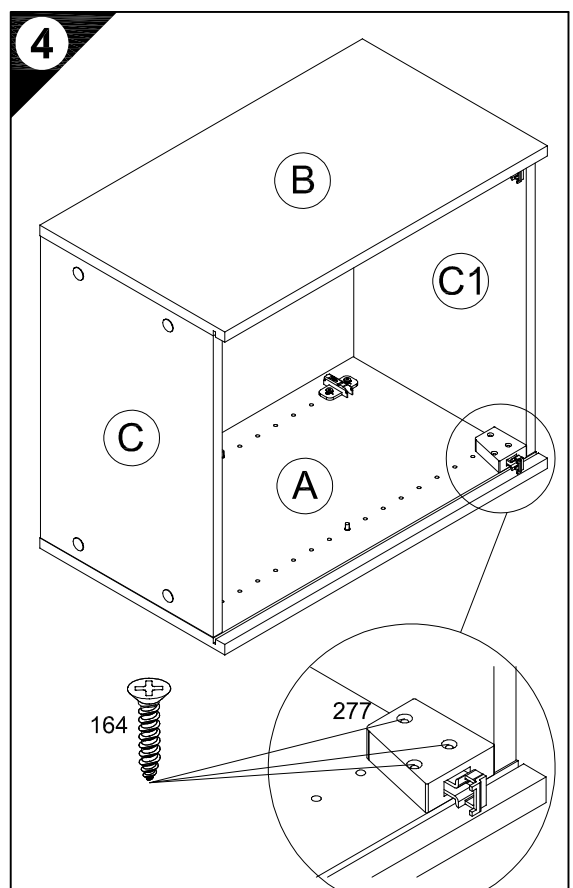
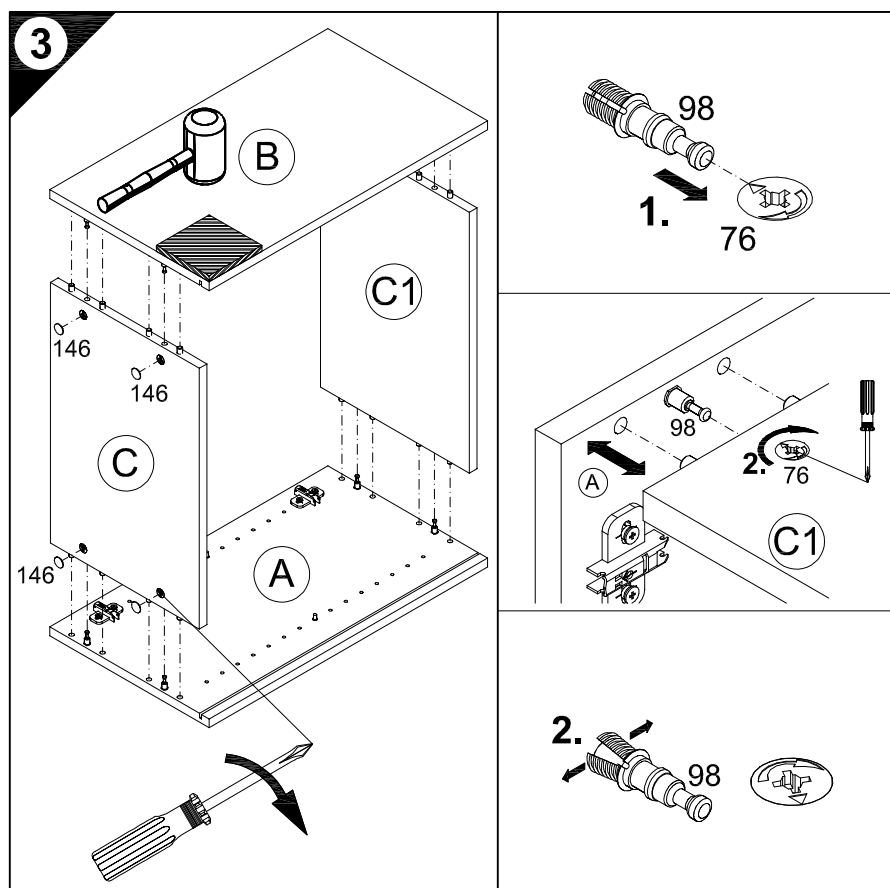

- | | | | |
|-----|---|-----|--|
| D | Holzunterlage verwenden!
Front andrücken, scharfen Bohrer verwenden und mit wenig Druck durchbohren! | H | Alkalmazzon fa alátétet!
Nyomja le az előlapot, használjon éles fúrót, és kis nyomással fúrja át! |
| GB | Use a wooden base!
Press front down, use sharp drill bit and, by applying slight pressure, drill a hole | CZ | Použijte dřevěný podklad!
Přitlačte čelo, použijte ostrý vrták a provrtejte pomocí malého tlaku! |
| F | Utiliser un support en bois !
Appuyer sur la façade, utiliser un foret bien affûté et percer en appliquant une faible pression ! | SLO | Uporabite leseno podlago!
Pritisnite ličnico ter z ostrim svedrom in z majhnim pritiskom izvrtajte luknjo! |
| NL | Houten onderlegger gebruiken!
Druk het front aan, gebruik een scherpe boor en oefen bij het boren weinig druk uit! | FIN | Käytä puualustaa!
Paina etulevy paikoilleen, käytä terävää poranterää ja poraa reikä vain kevyesti painamalla! |
| E | ¡Utilizar una base de madera!
¡Presionar el frente, utilizar una broca afilada y taladrar con poca presión! | S | Använd ett träunderlag!
Tryck fronten mot underlaget, använd vass borr och borra igenom med ett lätt tryck! |
| I | Utilizzare una base di legno!
Appoggiare la facciata, utilizzare una punta di trapano affilata e trapanare esercitando solo una leggera pressione! | SK | Použite drevený podklad!!
Pritlačte front, použite ostrý vrták a prevrtajte miernym tlakom! |
| RUS | Использовать деревянную подложку!
Прижать фасад, использовать острое сверло и просверлить с незначительным давлением! | RO | suport de lemn!
Împingeți frontul, utilizați un burghiu ascuțit și perforați exercitând doar o presiune redusă! |
| PL | Używać podkładkę z drewna!
Docisnąć front, użyć ostrego wiertła i przewiercić, używając małej siły nacisku! | TR | Ahşap taban kullanın!
Önden bastırın, keskin matkap ucu kullanın ve az basınç uygulayarak delin! |

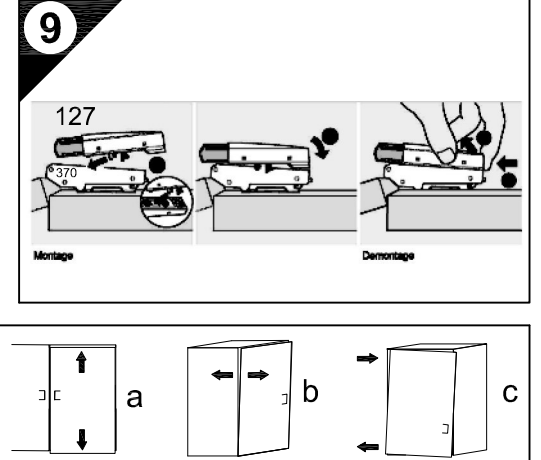
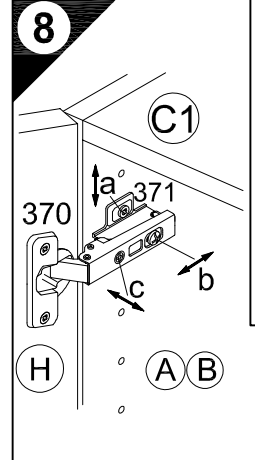
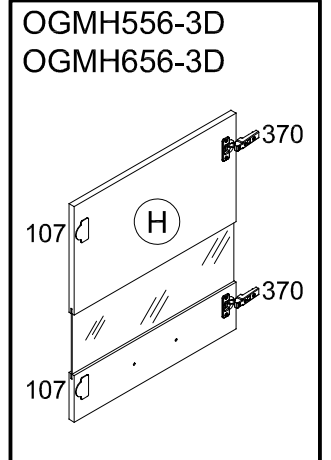
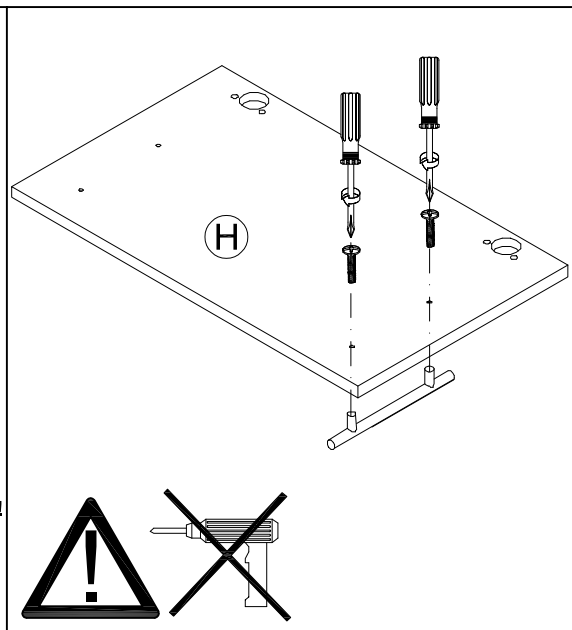

- | | |
|-----|---|
| D | Untergrund und Befestigungsmittel auf Eignung prüfen! |
| GB | Check substructure and fixings for suitability! |
| F | Contrôler si le support et les moyens de fixation sont bien adéquats ! |
| NL | Ondergrond en bevestigingsmaterial op functionaliteit controleren! |
| E | ¡Comprobar el suelo y los medios de fijación en cuanto a su aptitud! |
| I | Controllare l'idoneità del fondo e del materiale di fissaggio! |
| RUS | Основание и крепежный материал проверить на пригодность! |
| PL | Podłoże oraz materiały do zamocowania sprawdzić na ich przydatność! |
| H | Az alapelületet és a rögzítő anyagokat megfelelőség szempontjából ellenőrizni kell! |
| CZ | Přezkoušejte podklad a vhodnost upevňovacích prostředků! |
| SLO | Preverite, če se ujemajo spodnja stran in pritrilna sredstva! |
| FIN | Tarkista alustan ja kiinnitysvälineiden sopivuus! |
| S | Kontrollera att underlaget och fästmedlen är lämpliga! |
| SK | Preverte vhodnosť podkladu a upevňovacích prostriedkov! |
| RO | Verificați caracterul adecvat al suprafeței suport și al mijloacelor de fixare! |
| TR | Zeminin ve bağlantı elemanlarının uygunluğunu kontrol edin! |

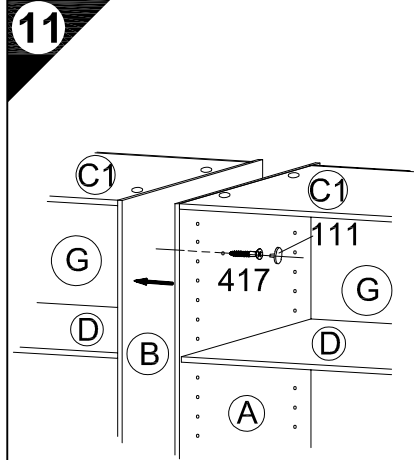
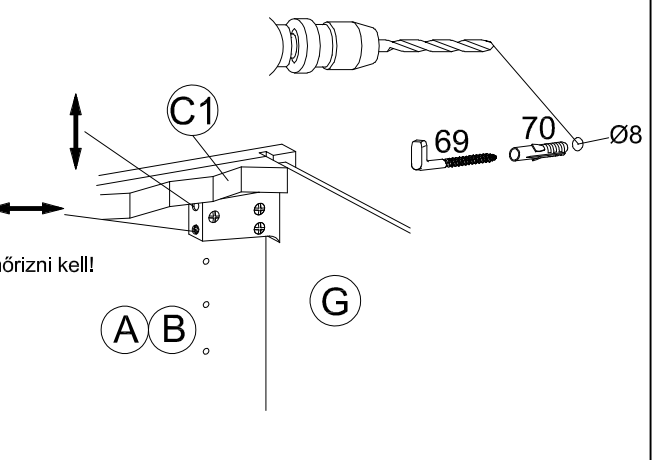



☑ OK
☒ not OK

Granitspüle / Granit Sink BERLIN 860 x 435 mm

1

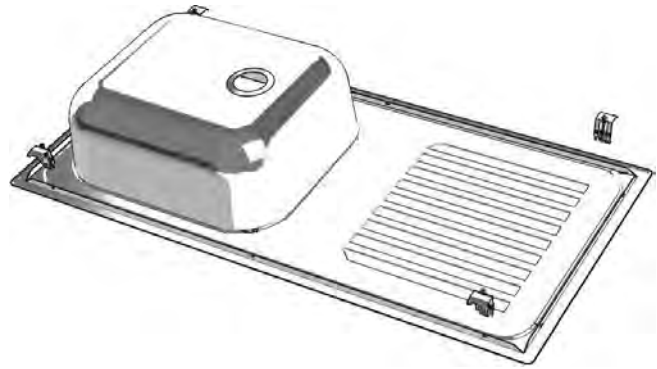

2

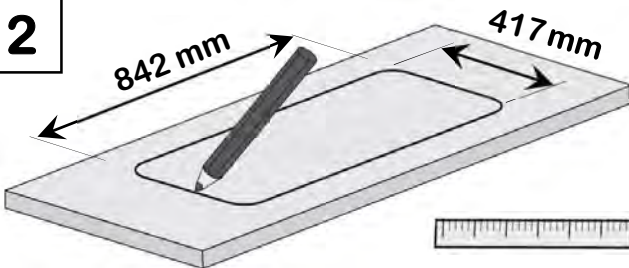

Ausschnitt / Cut out: 842 mm x 417 mm

3

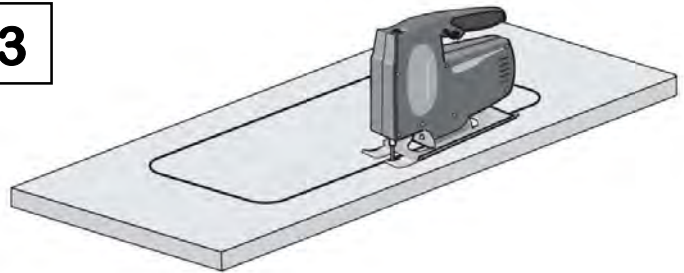

4

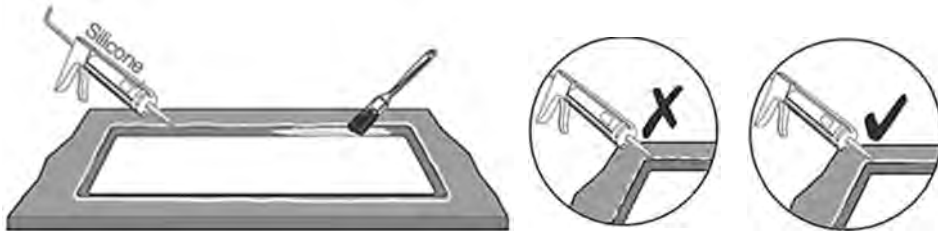

5

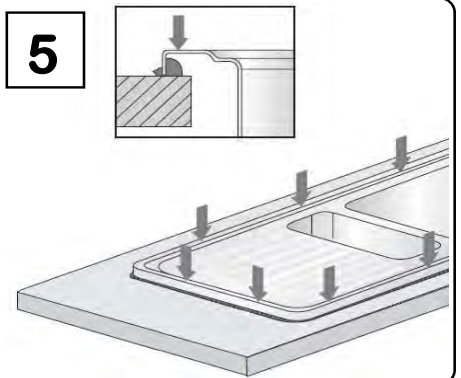

6

Von oben auf Markierung schlagen !
From Top punch on Label !

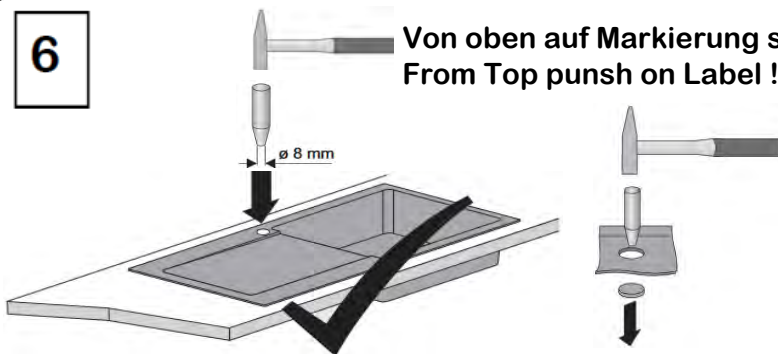

7

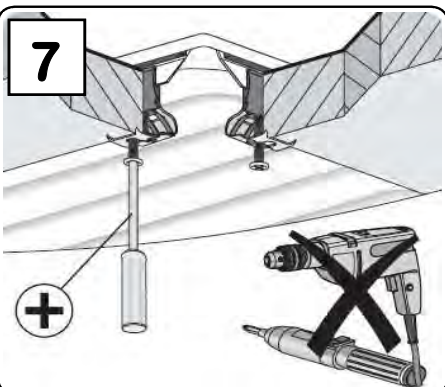

8

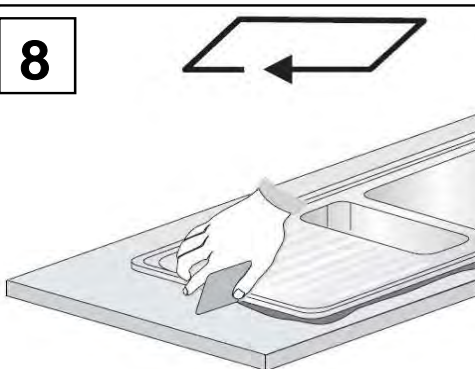

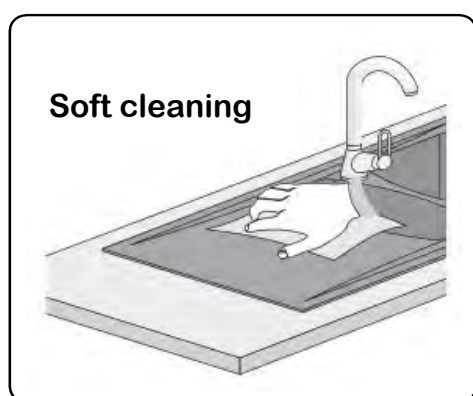
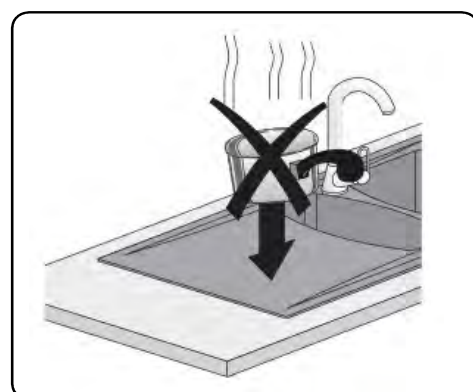
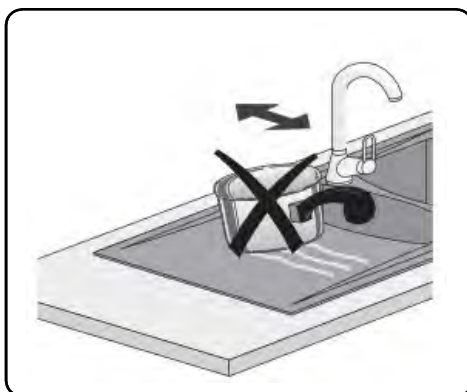
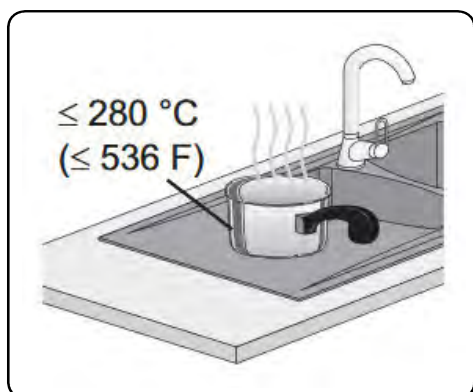

- Reinigen Sie das Waschbecken nach jedem Gebrauch mit warmem Wasser, Spülmittel und einem weichen Tuch.

- Nur die weiche Seite eines Spülschwamms zur Reinigung benutzen. Nicht kratzen.

- Verwenden Sie keine Scheuermittel oder Metallreiniger auf der Oberfläche der Spüle. Keine Metallscharber.

- **ACHTUNG! Reinigen der Spüle mit Produkten, die nicht für Spülen bestimmt sind (Spülmaschinentabletten, Entkalker, Abflussreiniger, Toilettenreiniger, Säuren usw.) kann das Waschbecken irreversibel beschädigen !**

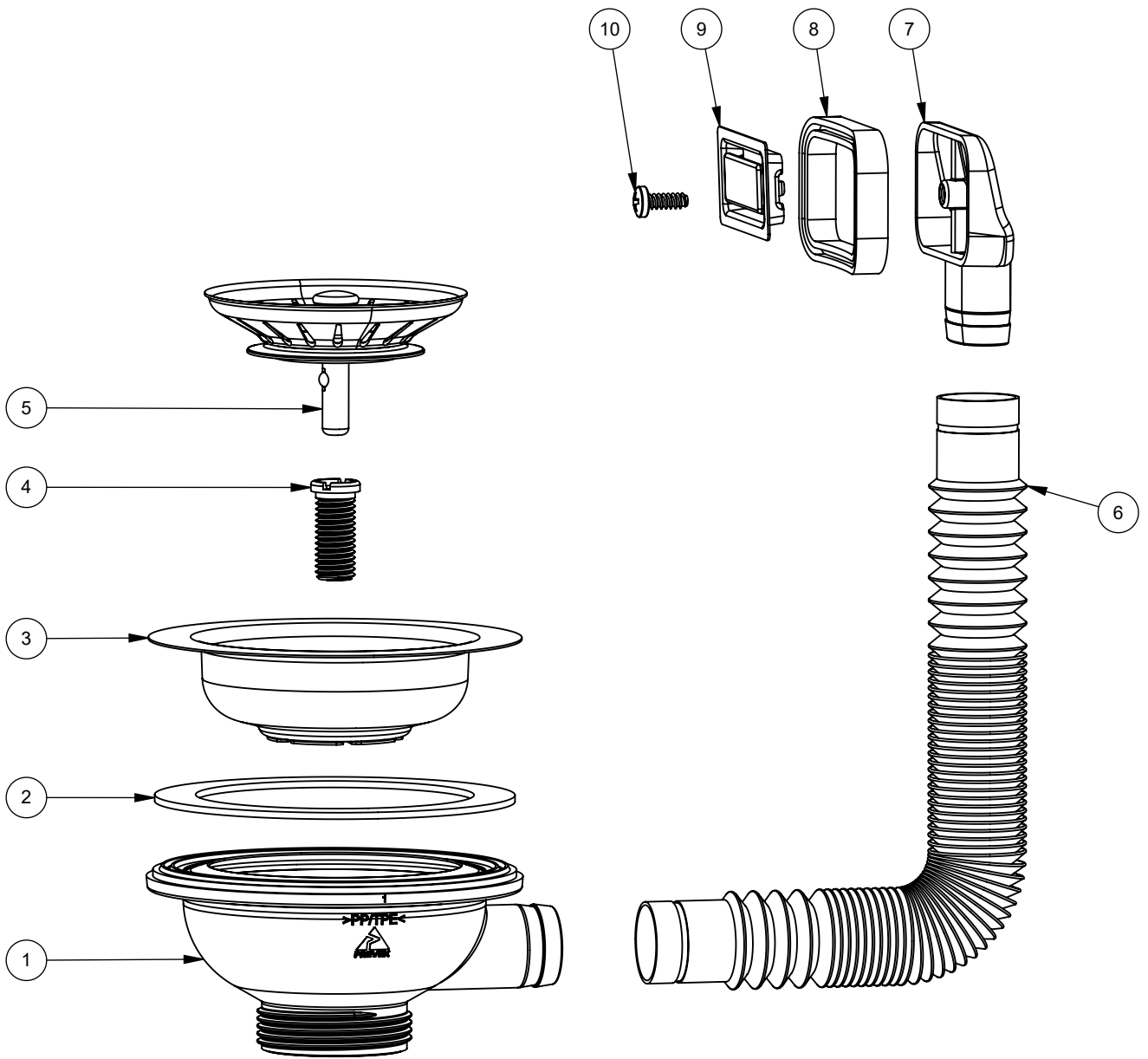

ITEM	PART NR	DESCRIPTION	QTY
1	631402	Waste valve 2K open	1
2	71169	Gasket 110/85x2	1
3	71387	Strainer 114x30	1
4	71431	Hole screw M12x30	1
5	690049	Strainer basket 24 mm, manual	1
6	71448	Overflow pipe 180-570	1
7	63114	House 61x40	1
8	61260	Gasket 66x44mm	1
9	71742	Overflow 55x30	1
10	71663	Screw 4,8x13 DIN7981F	1

Product Waste valve with overflow

Type

No WK2-D9D-001 ver.001

Date 29.01.2021 MW

New type New version Old version

PREVEX
ul. Cisowa 9, Niepruszewo 64-320 Buk Poland

Approved

Montageanleitung

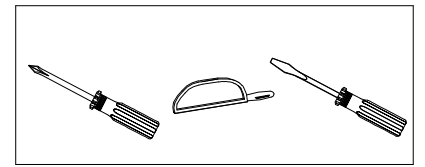

SO 180-...
SO 242-...
SO 278-...
SOH 278-...
SR-...

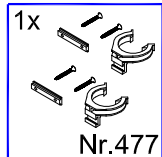

1

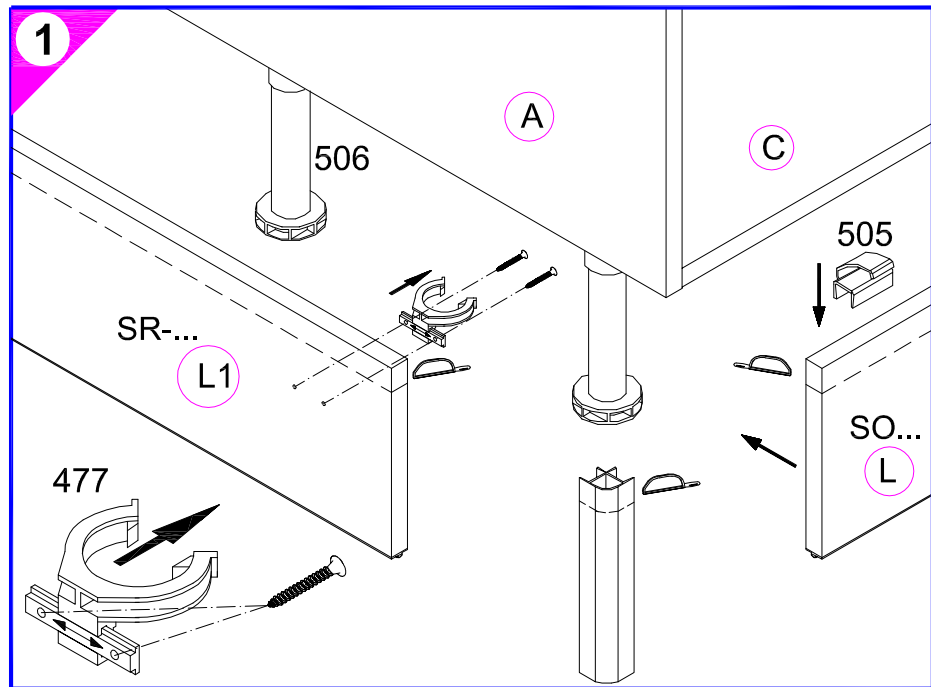

500582.C 10/09 sl

Montageanleitung

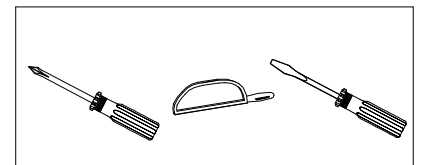

SO 180-...
SO 242-...
SO 278-...
SOH 278-...
SR-...

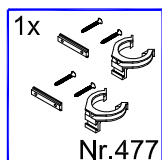

1

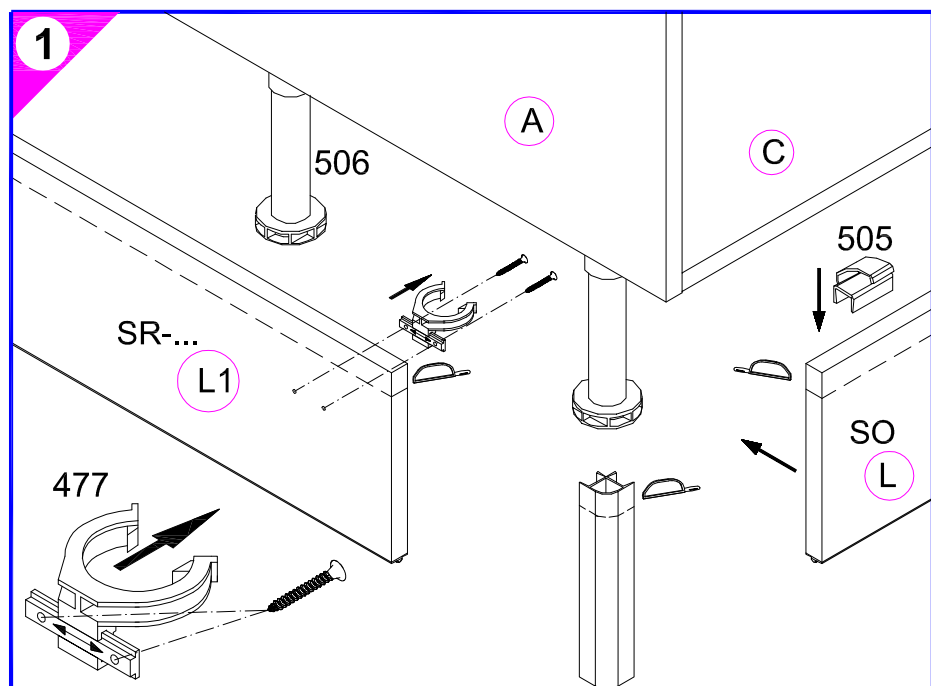

500582.C 10/09 sl

**OPTI
FIT**

JAKA-BKL GmbH
Jaka Straße 3
D-32351 Sternweide-Wehdem

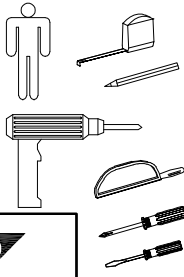

Montageanleitung WAP-205

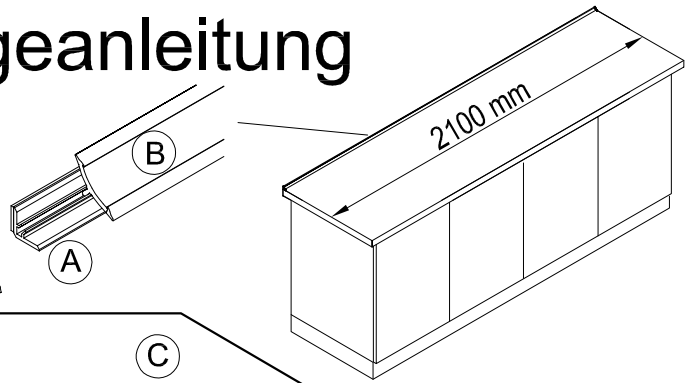

1 → 2 → 3 ...

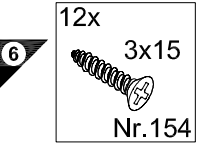

Service-Hotline
01805-678101
0,14€ pro Minute
++49 für Österreich
Auslandstarif pro Minute
service@jaka-bkl.de
voor Nederland en België
00800-40119350
benelux@jaka-bkl.de

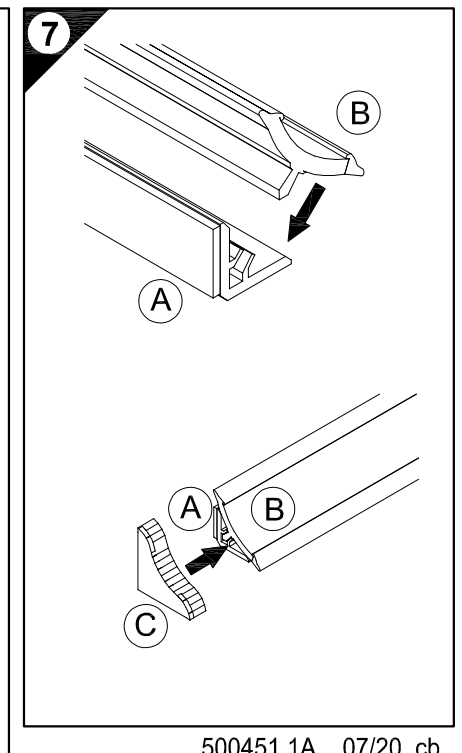
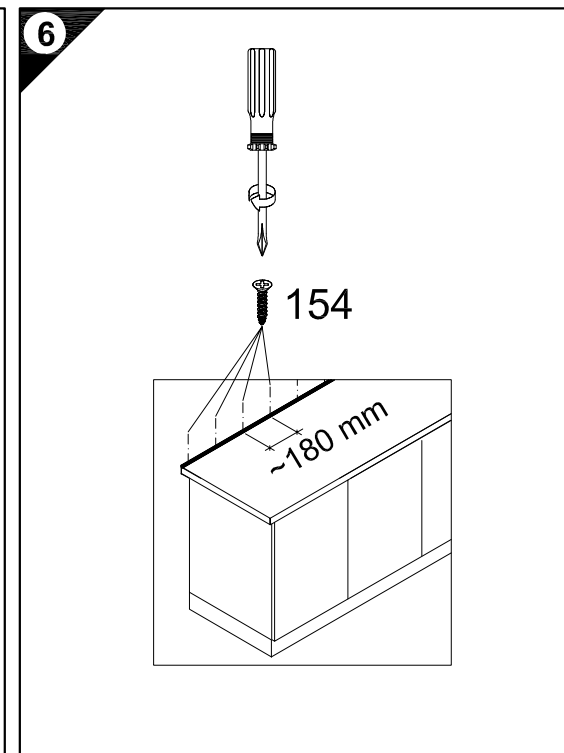
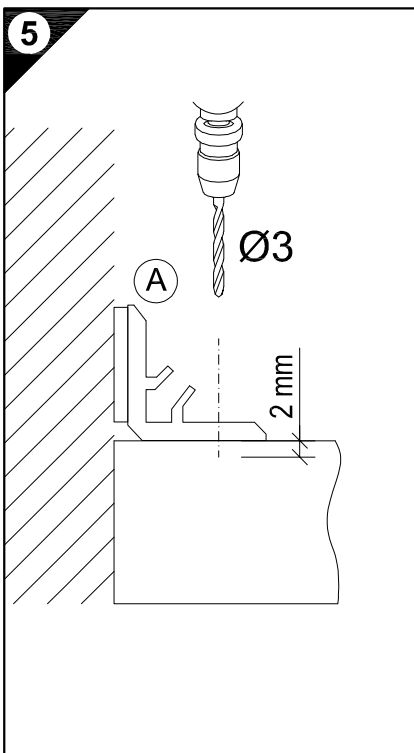
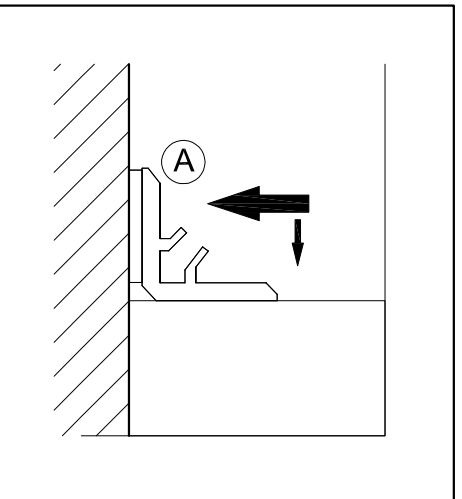
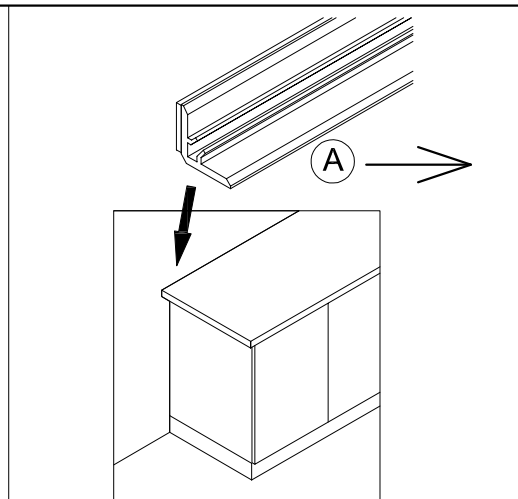
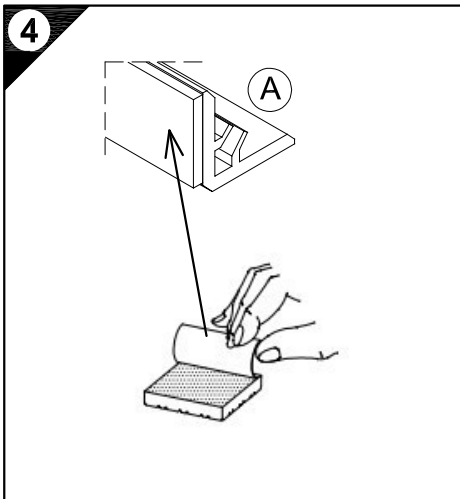
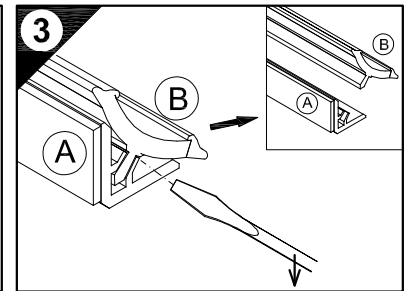
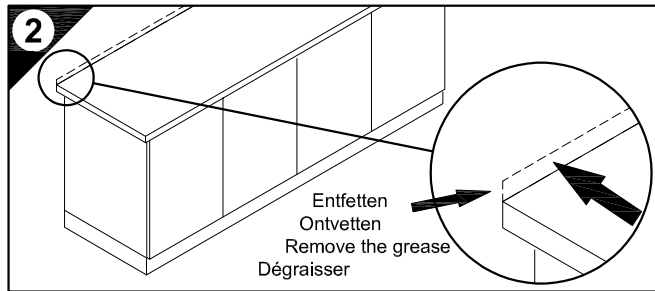
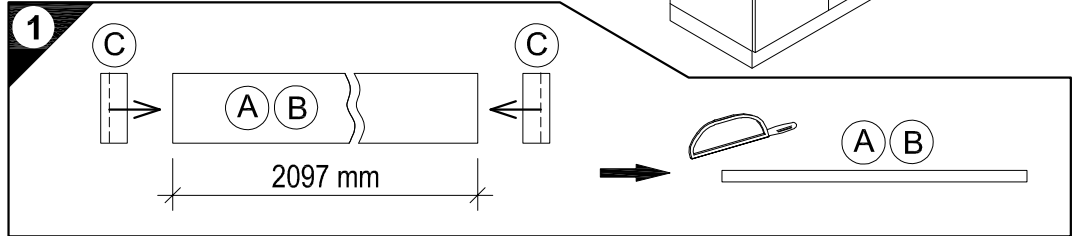

SERVICEKARTE

VH

Liebe Kundin, lieber Kunde,

obwohl wir unsere Möbel vor der Auslieferung einer eingehenden Endkontrolle unterziehen, kann es vorkommen, dass einmal ein Zubehörteil fehlt oder während des Transports beschädigt wird. Senden sie den Artikel bitte nicht zurück, sondern fordern sie einfach Ersatz für das Einzelteil bei unserer Kundenhotline an. Die Telefonnummern finden sie auf den Serviceseiten im Katalog.

Bitte benennen sie die Teile wie sie auf ihrer Aufbauanleitung angegeben sind. Fügen sie auch **Artikelnummer, Modellnamen und Farbnummer** bei. **Siehe Beispiel.**

Wir werden ihre Anforderung sofort bearbeiten und ihnen das Ersatzteil umgehend zusenden.

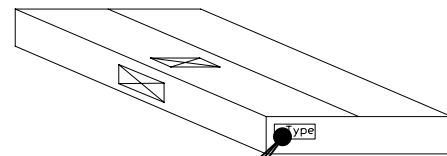
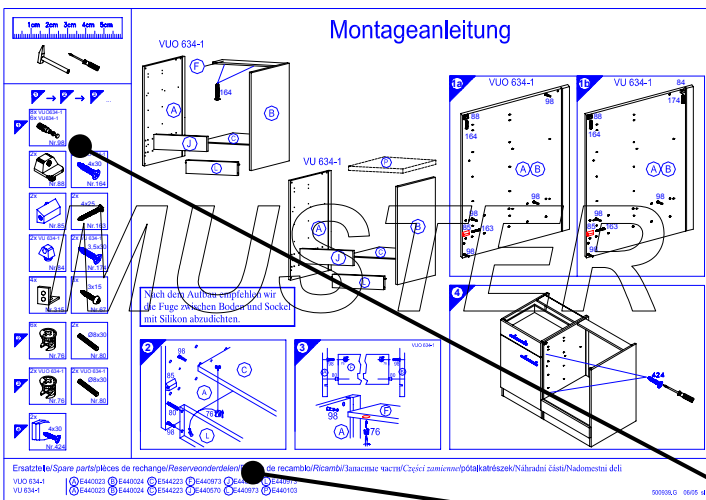

Muster - Bestellung		
Artikelnummer	123 456	
Modellname	Unterschrank VU634	
Farbe	TA 01	
Benötigte Ersatzteile:		
Bezeichnung	Nr.	Anzahl
Beschlagteil	98	2
Teil B	E 440 023	1

Bitte entnehmen sie die notwendige Ersatzteilnummer der Aufbauanleitung die zum Möbel gehört!

Kundendaten	
Kundennummer	
Name	
Vorname	
Strasse	
Haus-Nr.	
PLZ	
Ort	
Rechnungsdatum	
Tel. für Rückfragen	
Notizen:	

Ersatzteilbestellung		
Artikelnummer		
Modellname		
Farbe		
Benötigte Ersatzteile:		
Bezeichnung	Nr.	Anzahl
Grund der Ersatzteilanforderung:		

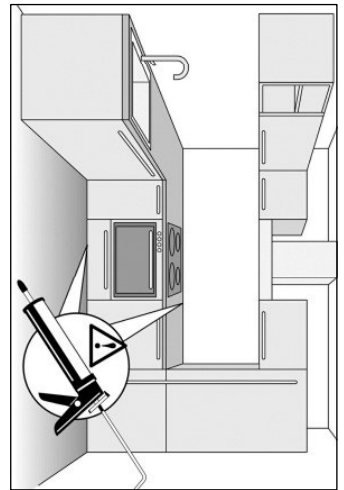
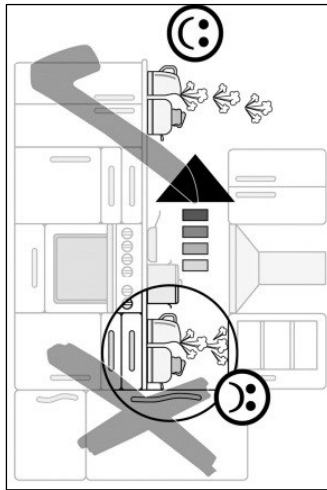
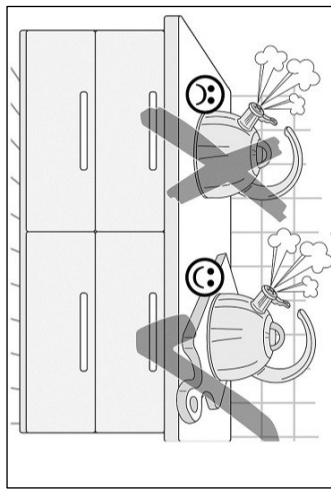
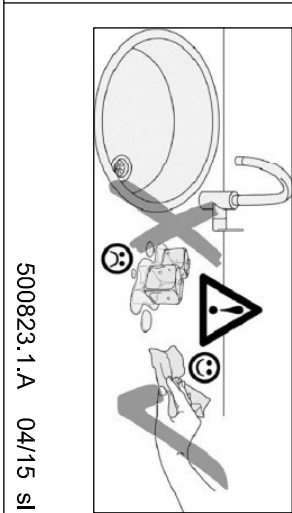
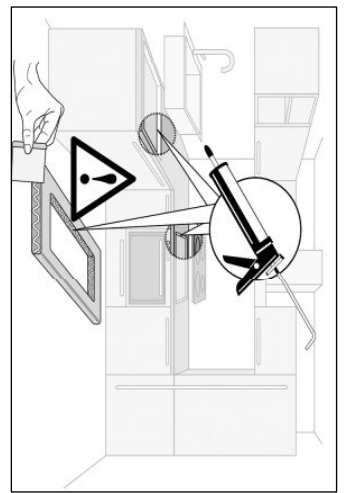
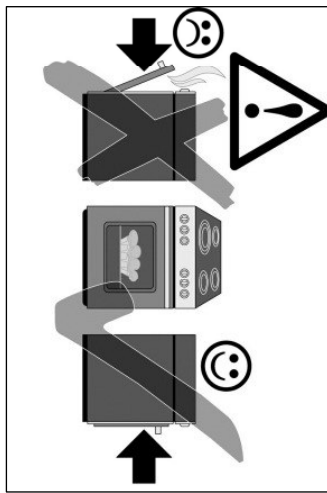
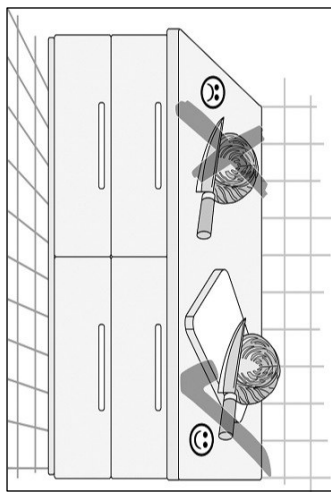
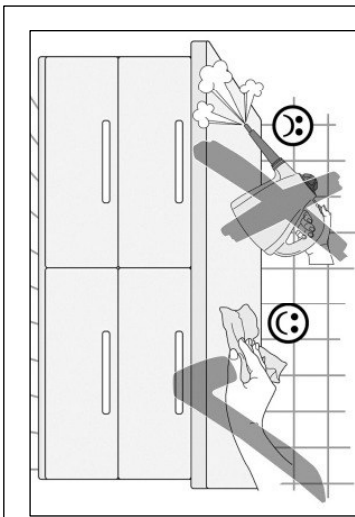

500823.1.A 04/15 SI

D Pflegehinweise

Kunststoff-Oberflächen:

Kunststoffbeschichtete Oberflächen/Fronten lassen sich mit haushaltsüblichen Reinigungsmitteln pflegen. Am besten geht das mit einem weichen Tuch, handwarmen Wasser und etwas Spülmittel. Verwenden Sie keine polierenden Reinigungsmittel oder harte Schwämme! Hartnäckige Flecken, wie Fettspritzer, Lack- oder Klebstoffreste, sind mit einem handelsüblichen Kunststoffreiniger zu beseitigen. Vor dem ersten Gebrauch dieser Mittel empfiehlt es sich, diese an einer nicht sichtbaren Stelle zu prüfen!

Glänzende Fronten: Diese Fronten nie trocken reinigen!
Die Verwendung von schleifenden Reinigungsmitteln (Mikrofaserlappen, Scheuerschwämme etc.) können zu erhöhter Bildung von Kratzern führen und sind kein Reklamationsgrund. Verwenden Sie daher am besten ein staubfreies Tuch oder ein feuchtes Fensterleder.

Einbauspülen und Herdmulden:

Einbauspülen, Herdmulden sowie alle nicht genannten Artikel aus rostfreiem Stahl pflegen Sie am besten mit einem Schwamm oder einem Vlies Tuch unter Verwendung von Spülmittel oder mit den bekannten Spezialpflegemitteln (Edelstahlreiniger, Metall-Polish). Bei Einbauspülen aus anderen Materialien wie Porzellan, Kunststoff, Acryl-Keramik sowie bei Edelstahlspülen milde Spül- oder Reinigungsmittel verwenden.

Bitte beachten Sie außerdem die speziellen Pflegehinweise der Hersteller!

Glaskeramik-Kochfelder:

Hartnäckige Verschmutzungen, Kalk- und Wasserflecken sowie glänzende Topfabrieb beseitigen Sie mit dem vom Hersteller empfohlenen Spezialreiniger (z.B. Cerafix, Stahlfix). Festgebrannte Verkrustungen (Zucker, Salz oder zuckerhaltige Speisereste) entfernen Sie, in noch heißem Zustand, mit einem Glasschaber.

Beachten Sie hierzu auch die Bedienungsanleitung des Geräteherstellers!

Griffe:

Verzichten Sie auf lösungsmittelhaltige und aluminiumschädigende Substanzen sowie auf Essigreiniger, da diese zu einer nicht mehr entfernbaren Fleckenbildung führen können.

GB Care instructions

Synthetic Surfaces:

Synthetic finishes on surfaces/fronts can be cared for with common household cleaners. It's best to use a soft cloth, hand warm water and a little washing-up liquid. Do not use any polishing cleaners or hard sponges! Stubborn marks, such as grease splashes, paint or adhesive residues can be removed with common, commercially available synthetic materials cleaners. However, it is recommended that these be tested on an inconspicuous area before using them for the first time!

Gloss Fronts: Never clean these fronts in the dry state!

Fitted sink units and all other articles made of stainless steel are best cleaned using a sponge or a fleece cloth with a washing-up liquid or known specialty cleaner (stainless steel cleaner, metal polish). Use mild washing-up or cleaning liquids on fitted sinks made of other materials, such as porcelain, synthetic material, acrylic ceramic as well as stainless steel. In addition, make sure to always follow the specific care instructions provided by the respective manufacturer!

Ceramic Glass Hobs:

Stubborn marks, limescale and water spots and shiny marks left by pots are best removed with special cleaners as recommended by the manufacturer. Use a glass scraper to remove burnt-on marks (sugar, salt or food spillages containing sugar) while still hot. Please also refer to the operating instructions provided by the appliance manufacturer!

Handles:

Avoid using substances containing solvents or which are harmful to aluminium, as well as cleaners containing vinegar, as these can cause permanent discolouration.

NL Onderhoudsinstructies

Kunststof-opervlakken:

Oppervlakken/fronten met een kunststof coating kunnen met een gangbaar huishoudelijk reinigingsmiddel worden verzorgd. Dat gaat het beste met een zacht doekje, handwarm water en een beetje afwasmiddel. Gebruik geen polijstende reinigingsmiddelen of harde sponjes! Hardnekkige vlekken, resten van lak of lijm, moeten met een gangbaar reinigingsmiddel voor kunststof worden verwijderd. Voor het eerste gebruik van dit middel is het aan te bevelen om dit op een niet zichtbare plek uit te proberen!

Glänzende fronten: Deze fronten nooit droog reinigen!

Het gebruik van schurende reinigingsmiddelen (microvezeldoekjes, schuursponsjes etc.) kunnen tot snellere vorming van krasjes leiden en zijn geen reden voor een reclamatie. Gebruik daarom het beste een stofvrij doekje of een vochtige zeem.

Inbouwgootstenen en kookplaten:

Inbouwgootstenen, kookplaten en alle niet genoemde artikelen van roestvast staal reinigt u het beste met een sponsje of een vliedoek met afwasmiddel of met de bekende speciale reinigers (vrs-reiniger, metaal-polish). Bij gootstenen van andere materialen zoals porselein, kunststof, acryl-keramiek en bij gootstenen van edelstaal milde afwas- of reinigingsmiddelen gebruiken. Neem bovendien de speciale reinigingsinstructies van de fabrikanten in acht!

Glaskeramische kookplaten:

Hardnekkig vuil, kalk- en watervlekken en glanzende slijtplekken van pannen verwijdert u met het door de fabrikant aanbevolen speciale reinigingsmiddel (bijv. Cerafix, Stahlfix). Aangekoekte en vastgebrande resten (suiker, zout of suikerhoudende voedselresten) verwijdert u, in nog hete toestand, met een glasschraper. Raadpleeg hiervoor ook de handleiding van de fabrikant van het apparaat!

Grepen:

Gebruik geen oplosmiddelhoudende en aluminium beschadigende substanties en geen schoonmaakazijn omdat deze tot vlekken kunnen leiden die niet meer te verwijderen zijn.

F Conseils d'entretien

Revêtements en plastique :

Les revêtements / fronts en plastique peuvent être entretenus au moyen d'un produit de nettoyage ménager courant. L'idéal est d'utiliser un chiffon doux, de l'eau tiède et un peu de produit pour la vaisselle. N'utilisez pas de produit de polissage ou d'éponges dures ! Éliminez les taches tenaces, telles que les projections de graisse et résidus de vernis ou de colle, au moyen d'un produit de nettoyage pour le plastique courant. Avant la première utilisation de ce produit, il est recommandé de tester celui-ci à un endroit dissimulé !

Fronts brillants : Ne nettoyez jamais ces fronts à sec !

L'utilisation de produits de nettoyage abrasifs (chiffons en microfibras, éponges abrasives, etc.) peut entraîner la formation accrue de rayures et ne peuvent justifier aucune réclamation. L'idéal est donc d'utiliser un chiffon non-pelucheux ou une peau de chamois humide.

Eviens encastrés et tables de cuisson :

Les éviens encastrés et tables de cuisson, ainsi que tous les éléments en acier inoxydable n'étant pas cités ici doivent être entretenus avec une éponge ou une peau de chamois, imprégnées de produit vaisselle ou d'un produit spécifique (détergent inox, polish métal). Les éviens encastrés fabriqués dans d'autres matériaux, tels que de la porcelaine, du plastique, de la céramique acrylique, ainsi que les éviens en acier inoxydable doivent être nettoyés au moyen de produit vaisselle ou détergent doux. Respectez également les consignes d'entretien spécifiques du fabricant !

Plaques vitrocéramiques :

Éliminez les taches tenaces, les taches de calcaire et d'eau, ainsi que les traces brillantes laissées par les casseroles au moyen du détergent spécial recommandé par le fabricant (par ex. Cerafix, Stahlfix). Éliminez les restes carbonisés (sucre, sel ou aliments sucrés) encore chauds au moyen d'un racloir. Respectez ici les instructions du fabricant de l'appareil !

Polignées :

N'utilisez pas de substances à base de solvant et détériorant l'aluminium ou produits à base de vinaigre ; ceux-ci peuvent causer des taches indélébiles.

