

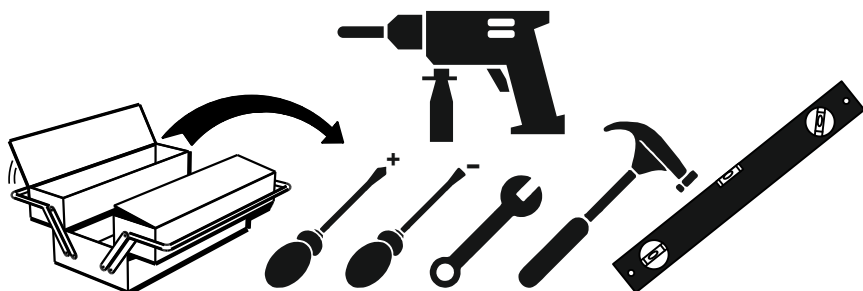

MULTIMO

101M-HAPPY DESK

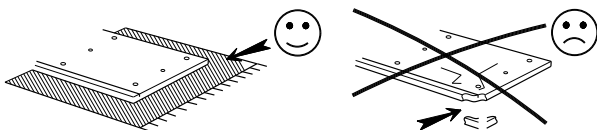

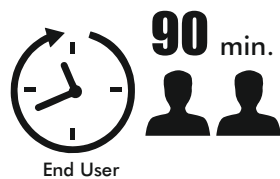
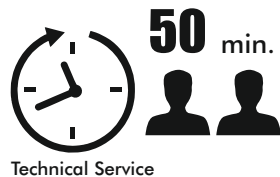
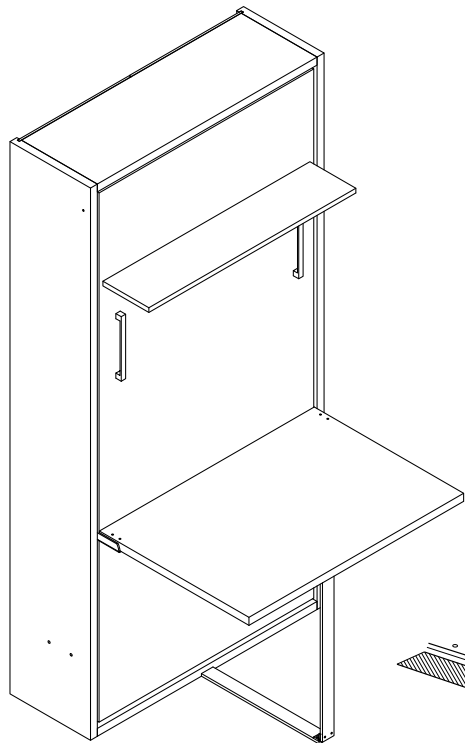

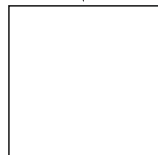







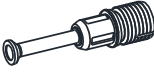

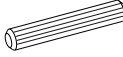

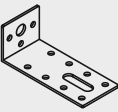
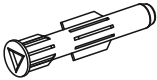
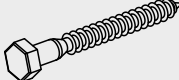
VIDEO

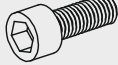
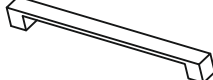

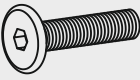
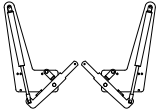
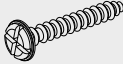
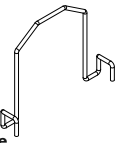
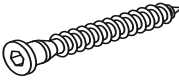
link

Track Title	Piece	(inch)			(mm)			
		Thickness	Length	Width	Piece	Thick	Height	Most
A		1,18	81,89	13,78	2	30	2080	350
B		1,18	37,64	12,95	1	30	956	329
C		1,18	37,64	13,74	1	30	956	349
D		0,71	37,64	10,24	1	18	956	260
E		0,71	35,43	7,87	1	18	900	200
F		0,71	78,46	36,77	1	18	1993	934
G		0,71	36,77	25,59	1	18	934	650
H		0,31	80,98	19,09	2	8	2057	485

Accessories List

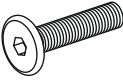
MXN 02  12 / piece DSE - 01 (40x90x32) mm	MNG - 01  12 / piece DD - 01 (R10)	KVL 01  12 / piece TFC - 01(8x70) mm	TAP - 01  12 / piece VTB - 01 (4,8x16) mm
 2 / piece PL - 02 (8x22x1) mm	 2 / piece IM - 01 (6x30) mm	 2 / piece KP - 01 (224) mm	 8 / piece VKP - 01 (22) mm
 2 / piece CT - 01 (6x40) mm	 4 / piece MKZ - 02	 2 / piece VD - 02 (3,5x25) mm	 4 / piece TTC 01
 6 / piece VDA - 01 (6,5x50) mm	 1 / piece AVT - 01	 12 / piece H 01	 3 / piece OT-054
 4 / piece HB - 03 (6x16) mm	 4 / piece SN - 01 (M6)	 1 / piece PL - 01 (6x19x1) mm	 2 / piece CT - 08 (6x25) mm
 2 / piece	 4 / piece	 4 / piece	 2 / piece

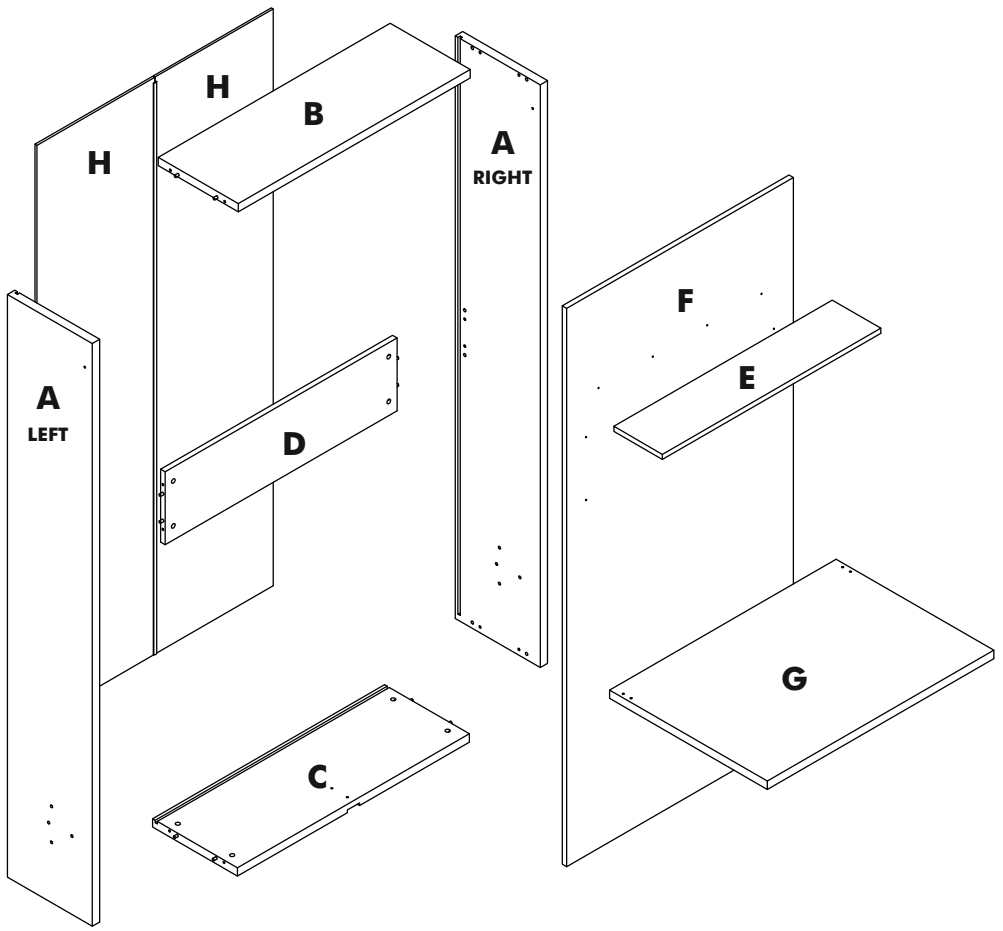

SC - 33

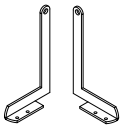

2 / piece

LM-01

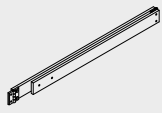

1 / piece

PL - 05 (8x16x2) mm



2 / piece

OT 10

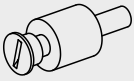

2 / piece

SN - 02 (M8)



2 / piece

STEP 1



**TRACK TITLE
A LEFT / A RIGHT**

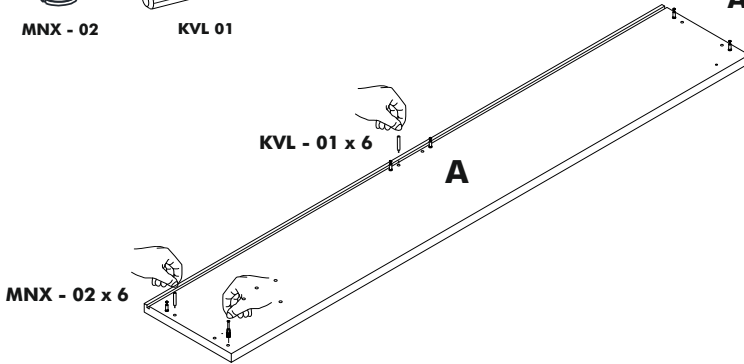

STEP 2

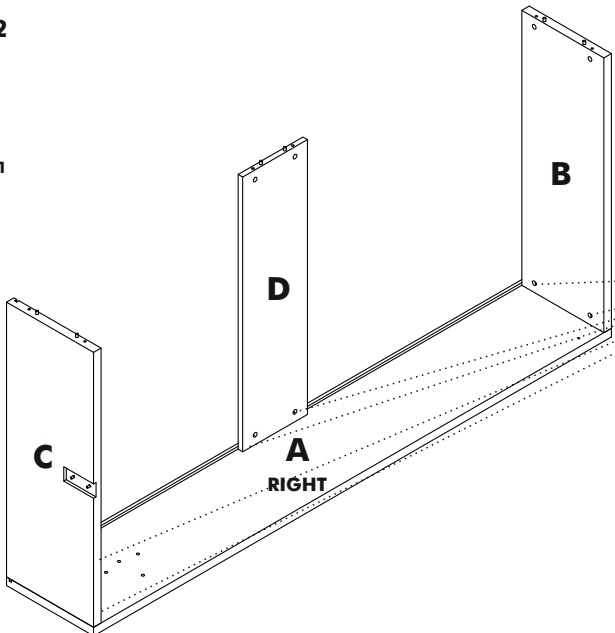

VIDEO

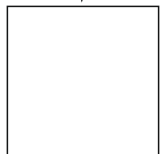

link

STEP 3

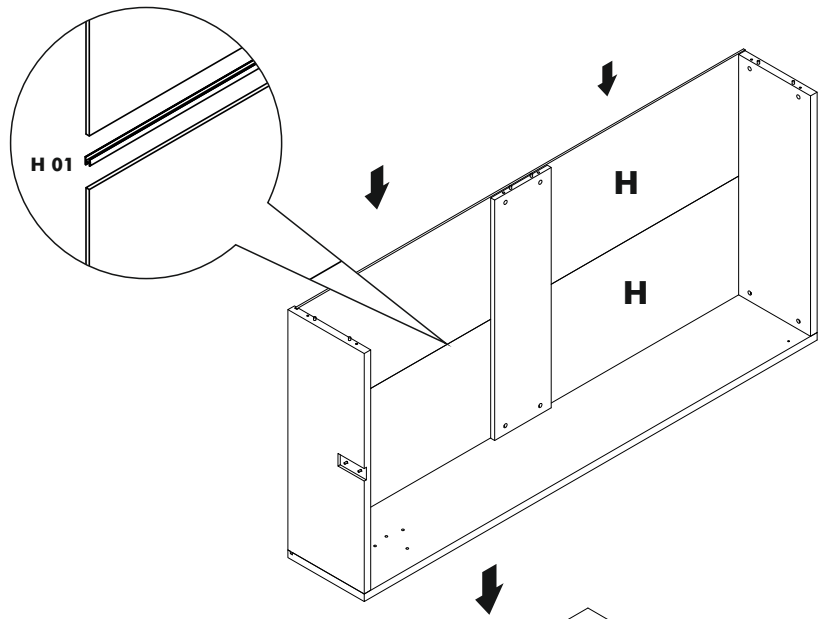

STEP 4

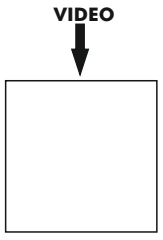
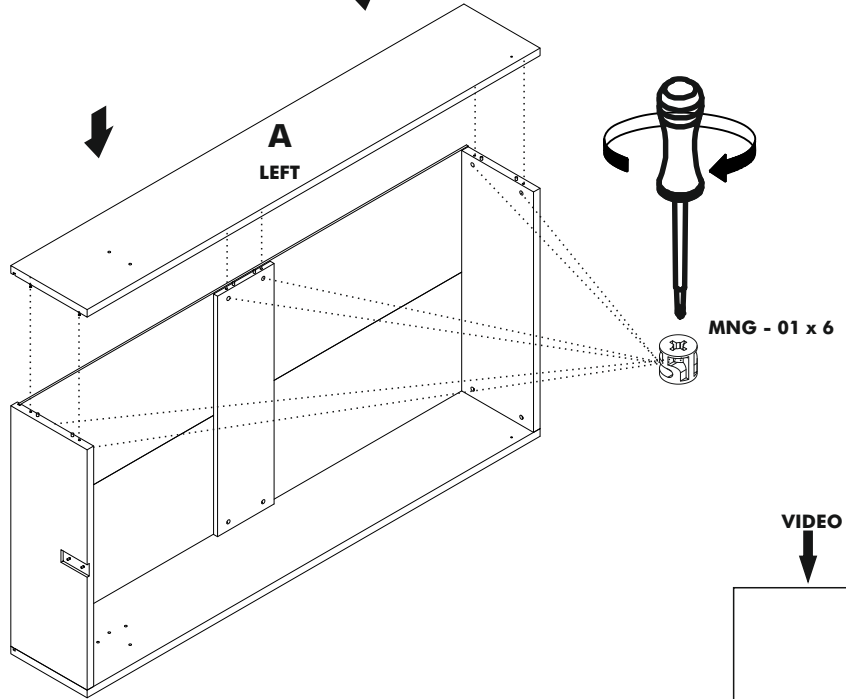

STEP 5

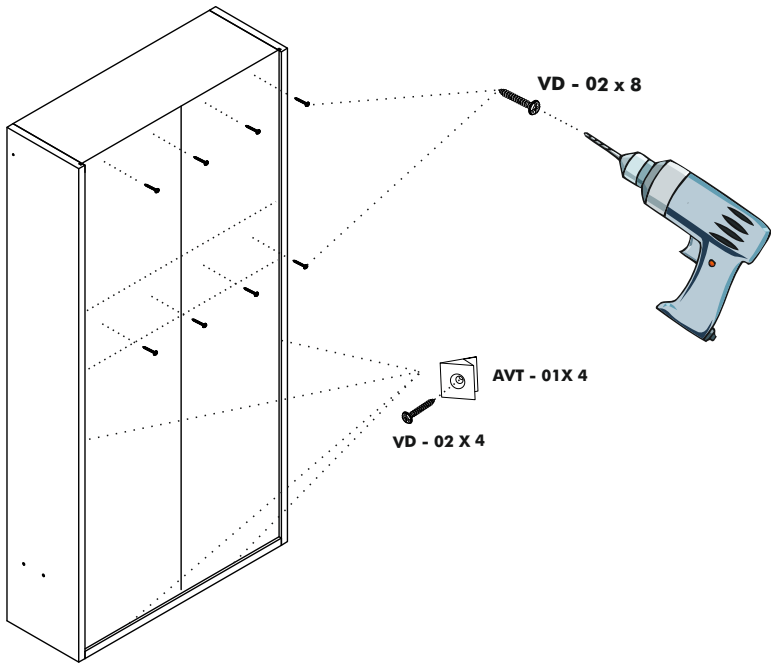

STEP 6

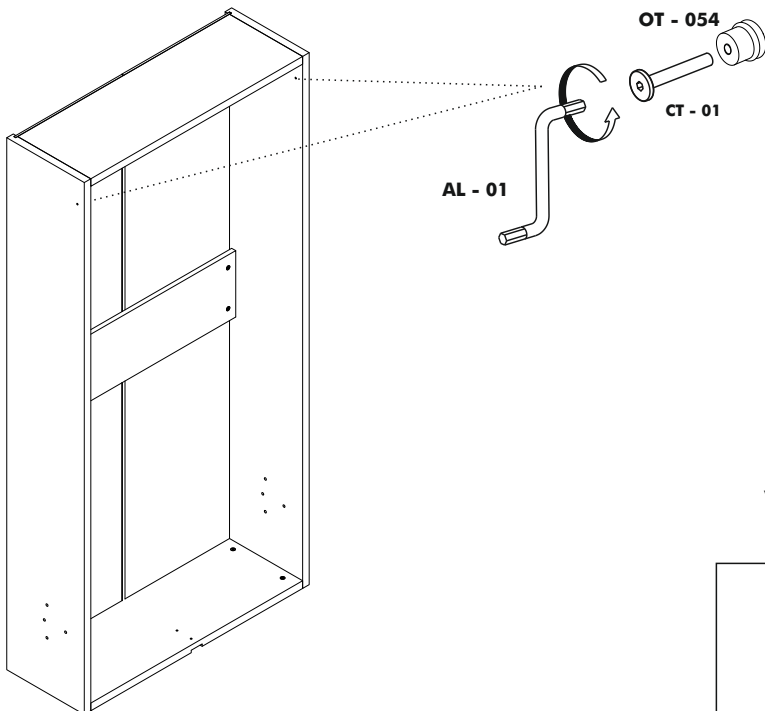

STEP 7

CAUTION
DO NOT UNLOCK BEFORE INSTALL

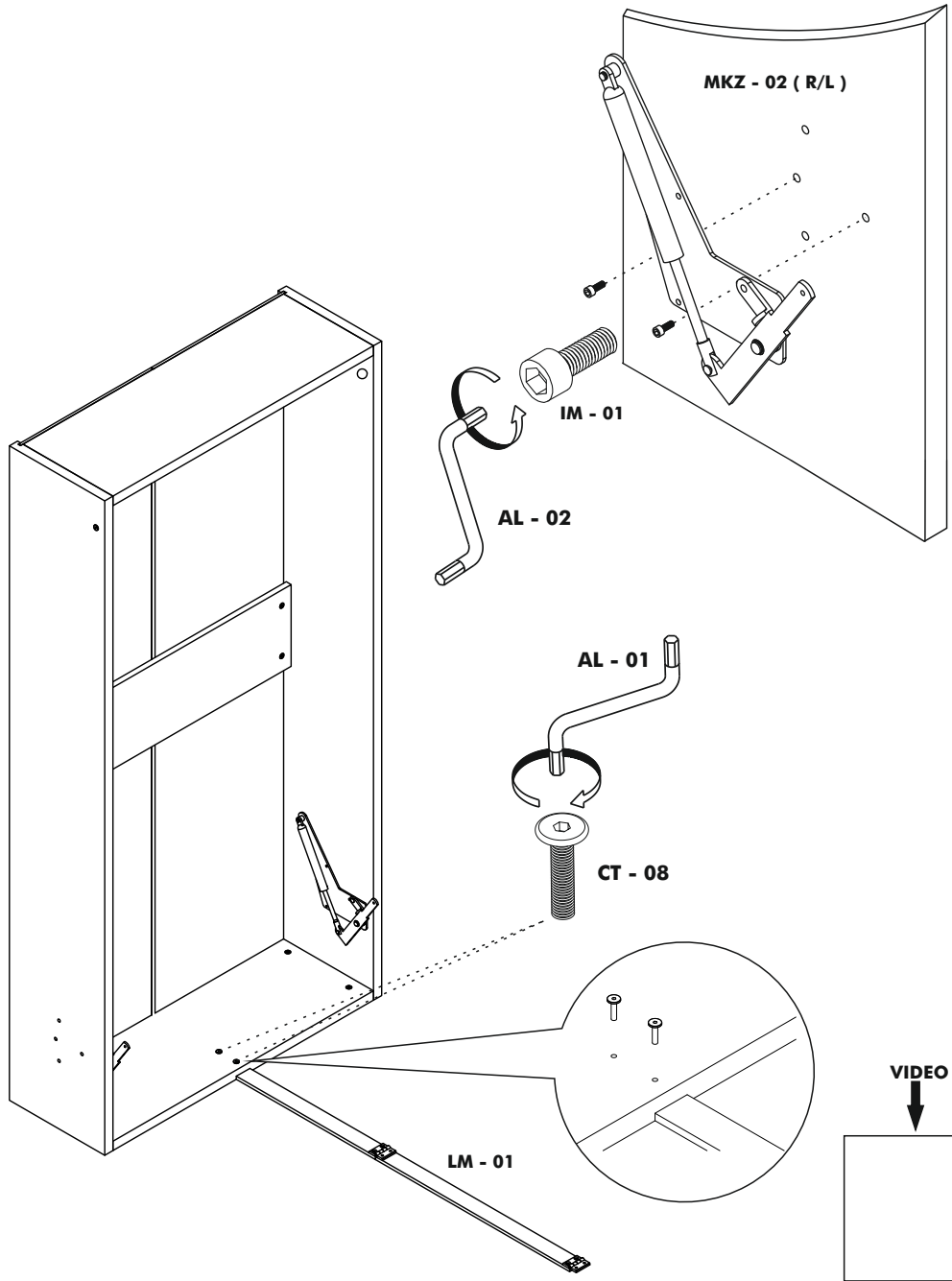

STEP 8



Ø 10 mm / 0,254 inch

DD - 01

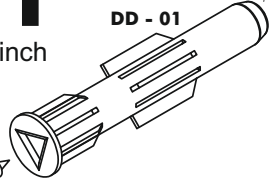

PL - 02

TFC - 01

VTB - 01

DSE - 01

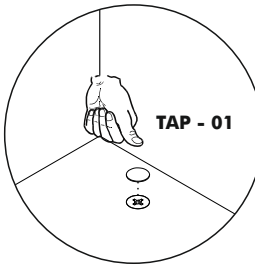
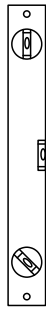

TAP - 01

VIDEO

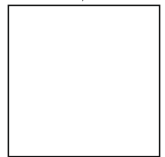

link

STEP 9

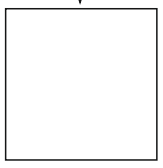
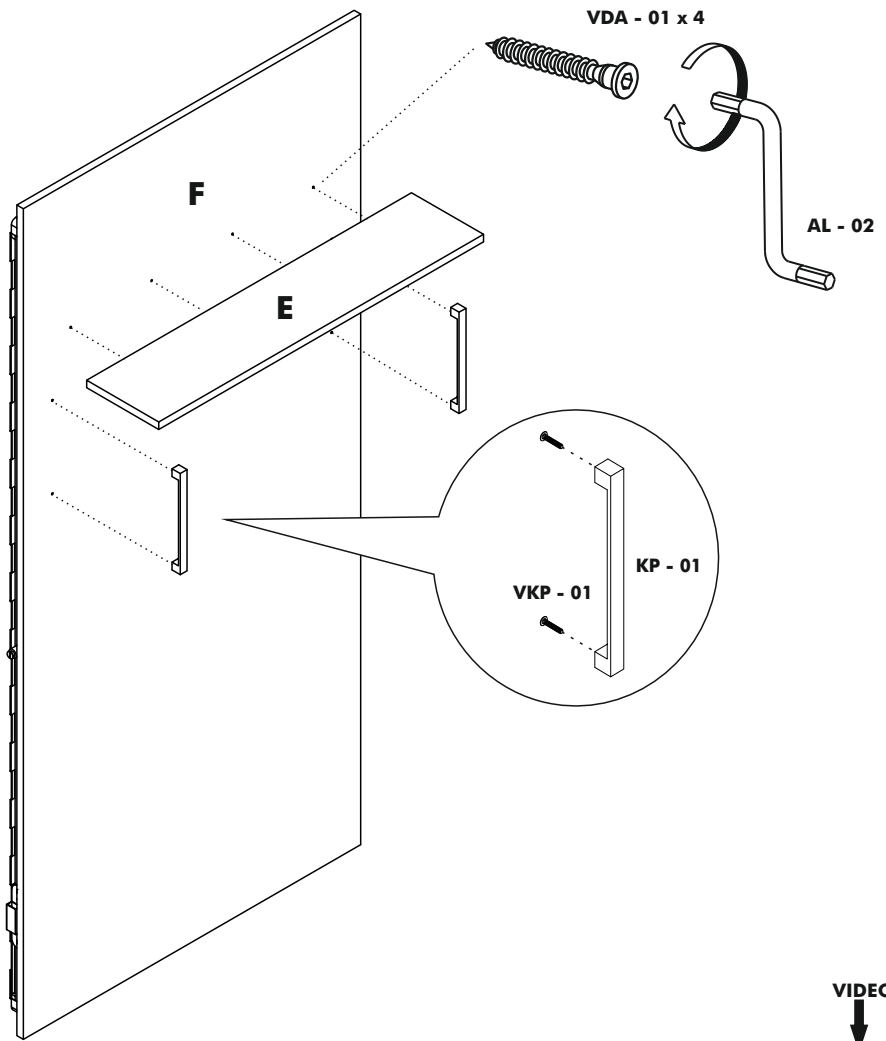

link

STEP 10

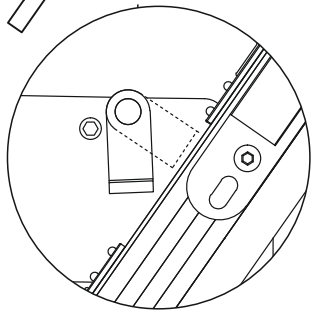
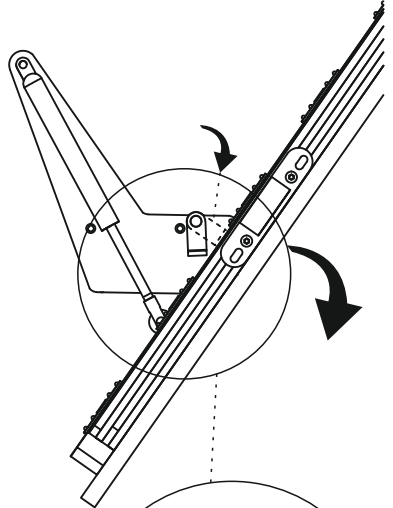
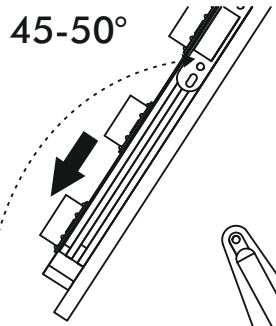
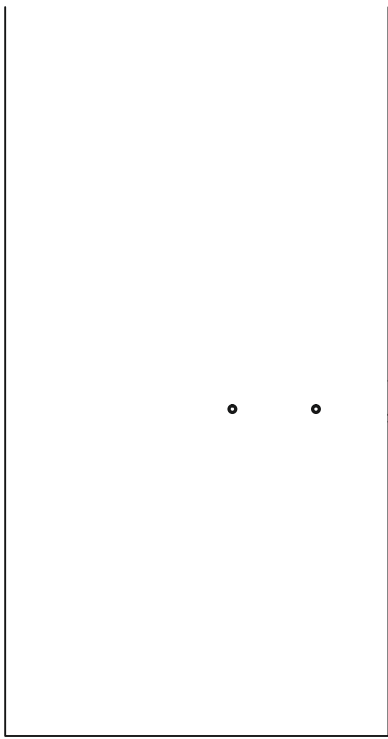

LET THE STOPPER LOCK MOVE DOWN !!!

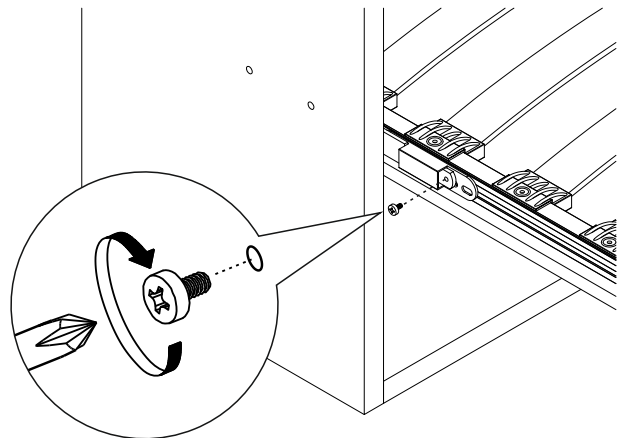

VIDEO

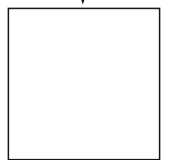

link

STEP 11

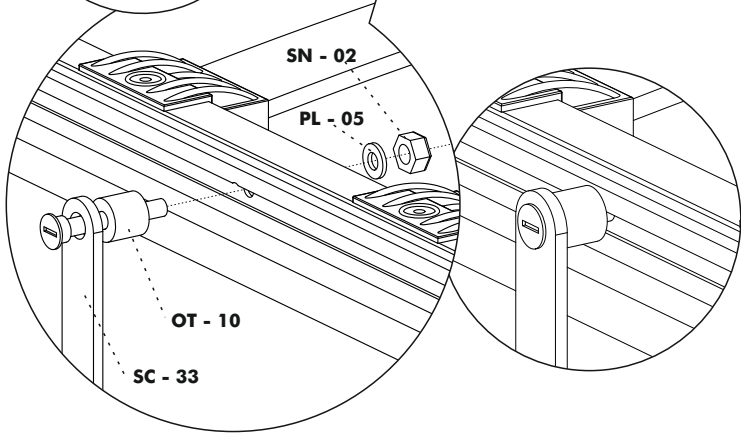
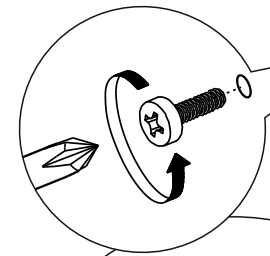
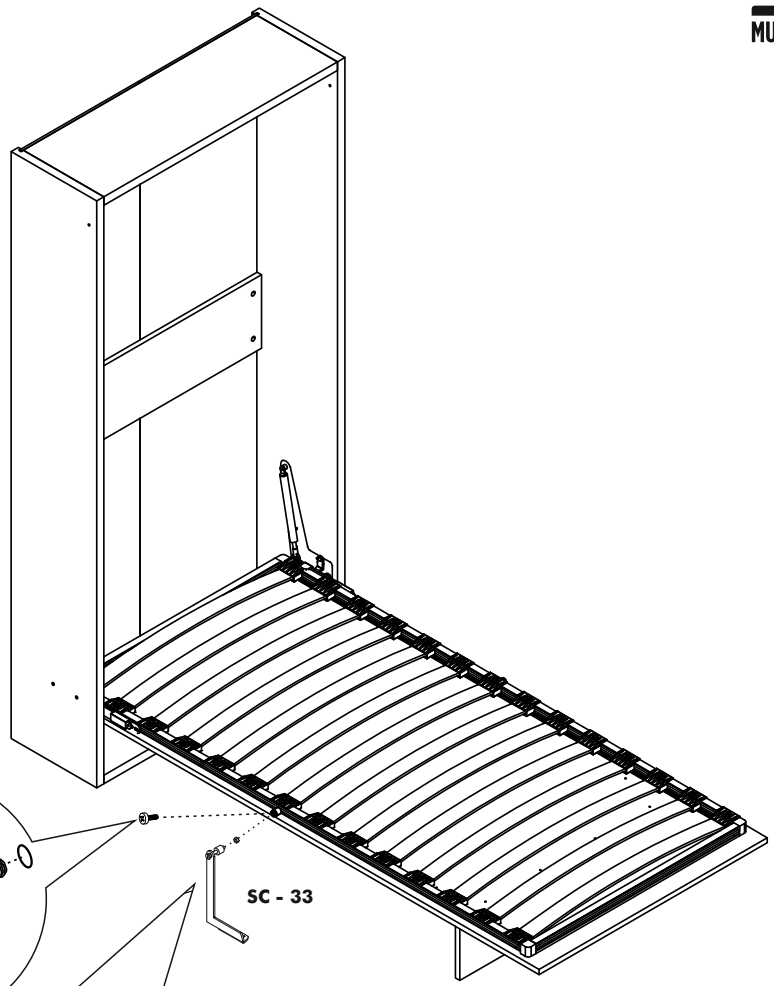

VIDEO

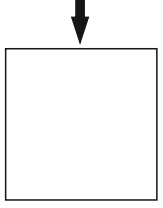

link

STEP 12

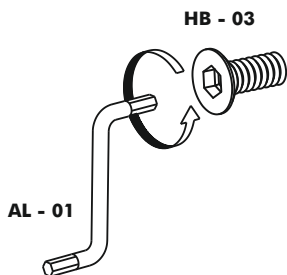
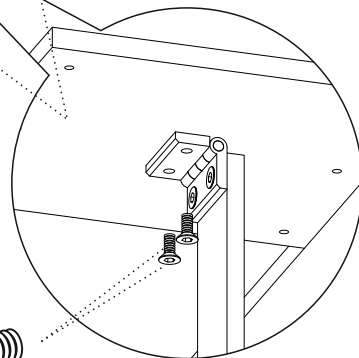
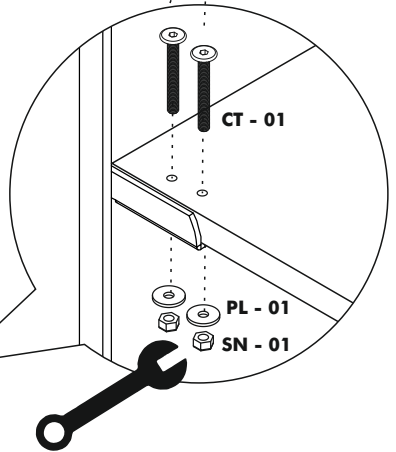
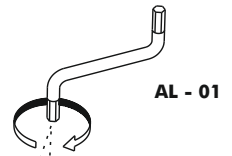
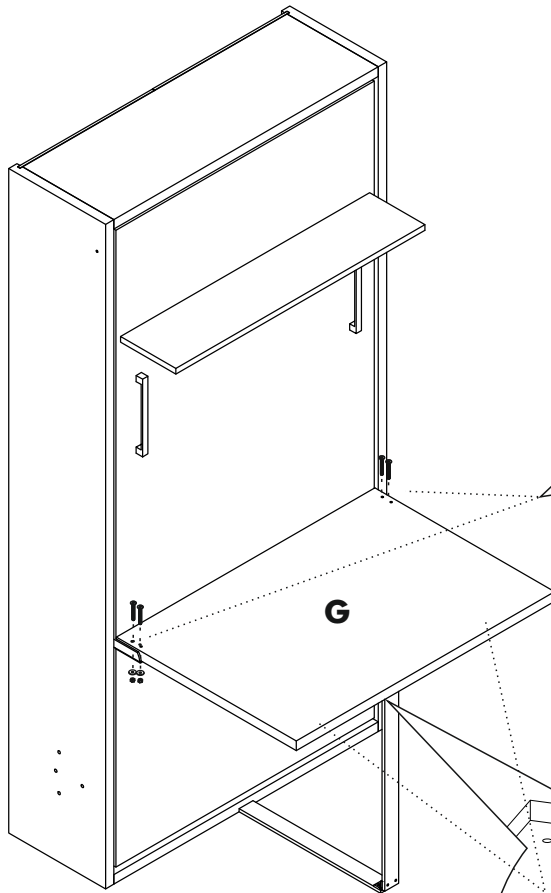

VIDEO

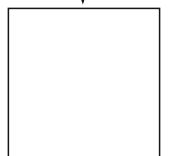

link

STEP 13

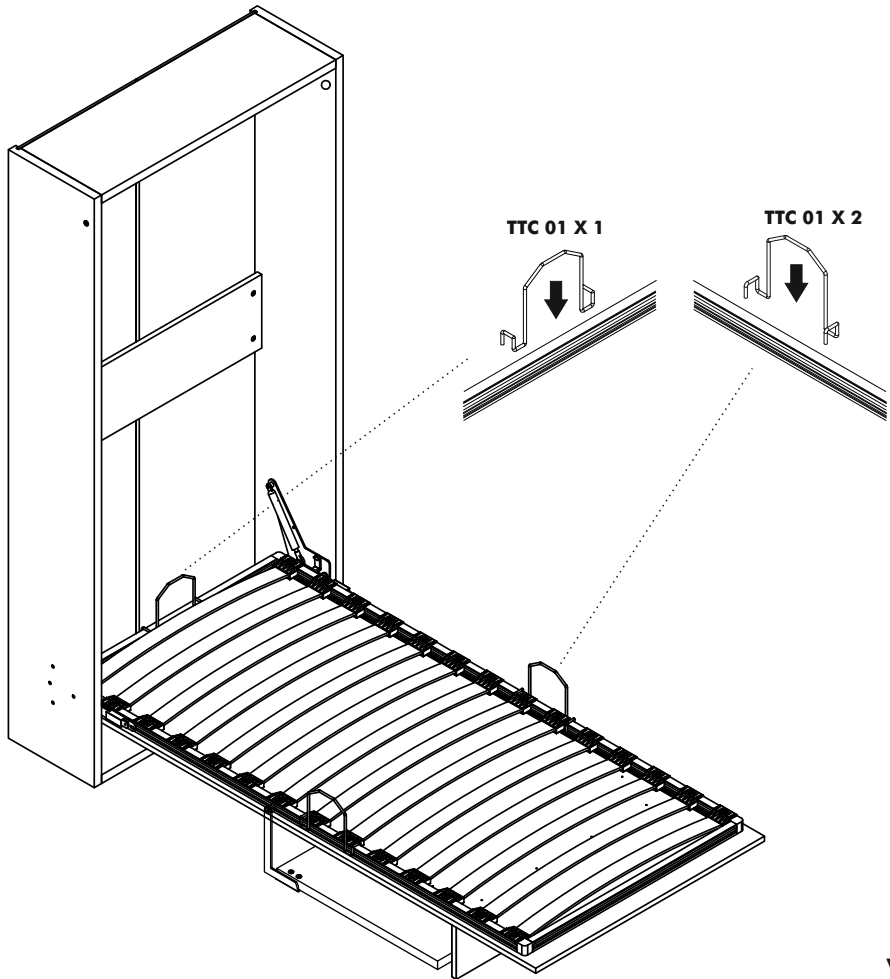

VIDEO
↓

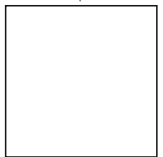

link

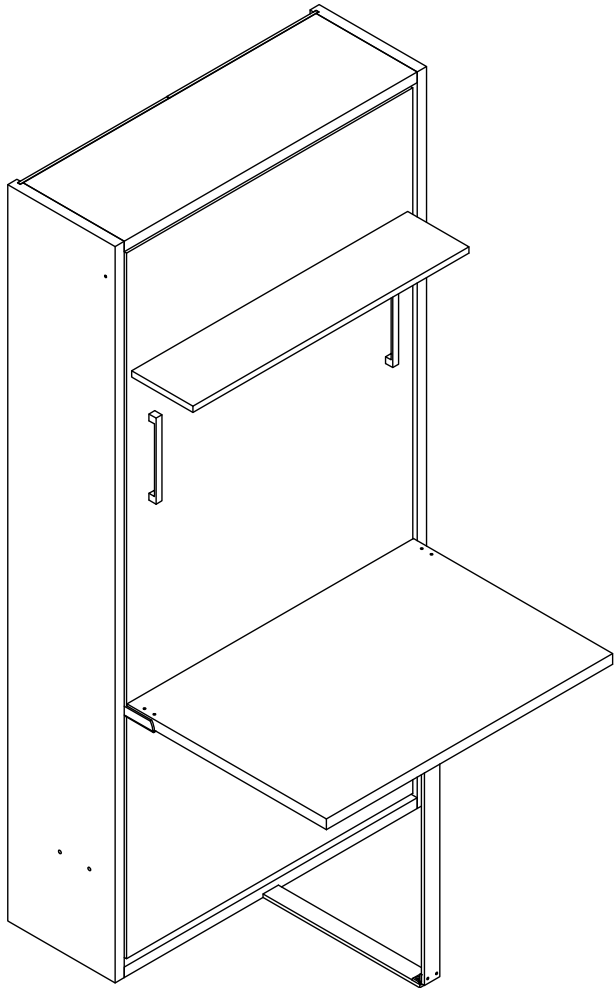

ATTENTION / HOW TO / READ ME / OWNER'S GUIDE

1. When mounting on a regular drywall, furniture must be fastened to wood or metal studs. Solid walls made of brick, concrete or similar strong material are also acceptable. Do not mount furniture to paper-mache or sheet rock like material without properly attaching to stud.
2. For safety and product longevity you must periodically inspect the mounting and mechanical connections for integrity and tightness. Confirm hardware remains properly affixed and connections snug.
3. Wall Bed mattress thickness may not exceed 8 inch. Take care to remove pillows and excess blankets before closing. Doing so keeps mechanism free of obstruction and unnecessary stress.
4. Do not lean or rest heavy objects on side or top of furniture. This may cause balance issues and compromise the integrity of your mounting connections.
5. Please use the furniture's beds, desks and shelving as intended. Not designed to be sat, stood, leaned, jumped (etc) on. Improper use may cause personal injury and damage to property.
6. With seasonal humidity change you must inspect interior and exterior of furniture.
7. Single, Twin, Twin XL beds accommodate the weight of one person. Improperly sleeping more than one person risks injury to person and damage to property.
8. Before any un-mounting or disassembly please contact Multimo for technical support and instruction. Failure to properly detach risks injury to person and damage to property.
9. For Bunk Beds:
 - a. Always use provided ladder when accessing top bunk.
 - b. Be slow, careful and aware of surroundings when opening top bunk.
 - c. Do not horseplay. Beds are to be slept on only.
 - d. Some have legs that fully extend when open- be aware of where the leg is and will be.



MULTiMO

www.multimo.com