

Montageanleitung | Instructions de montage Assembly Instructions | Instrucciones de montaje

**SKU NUMBER: N616P228368/N616P228369
N616P228370/N616P228371**

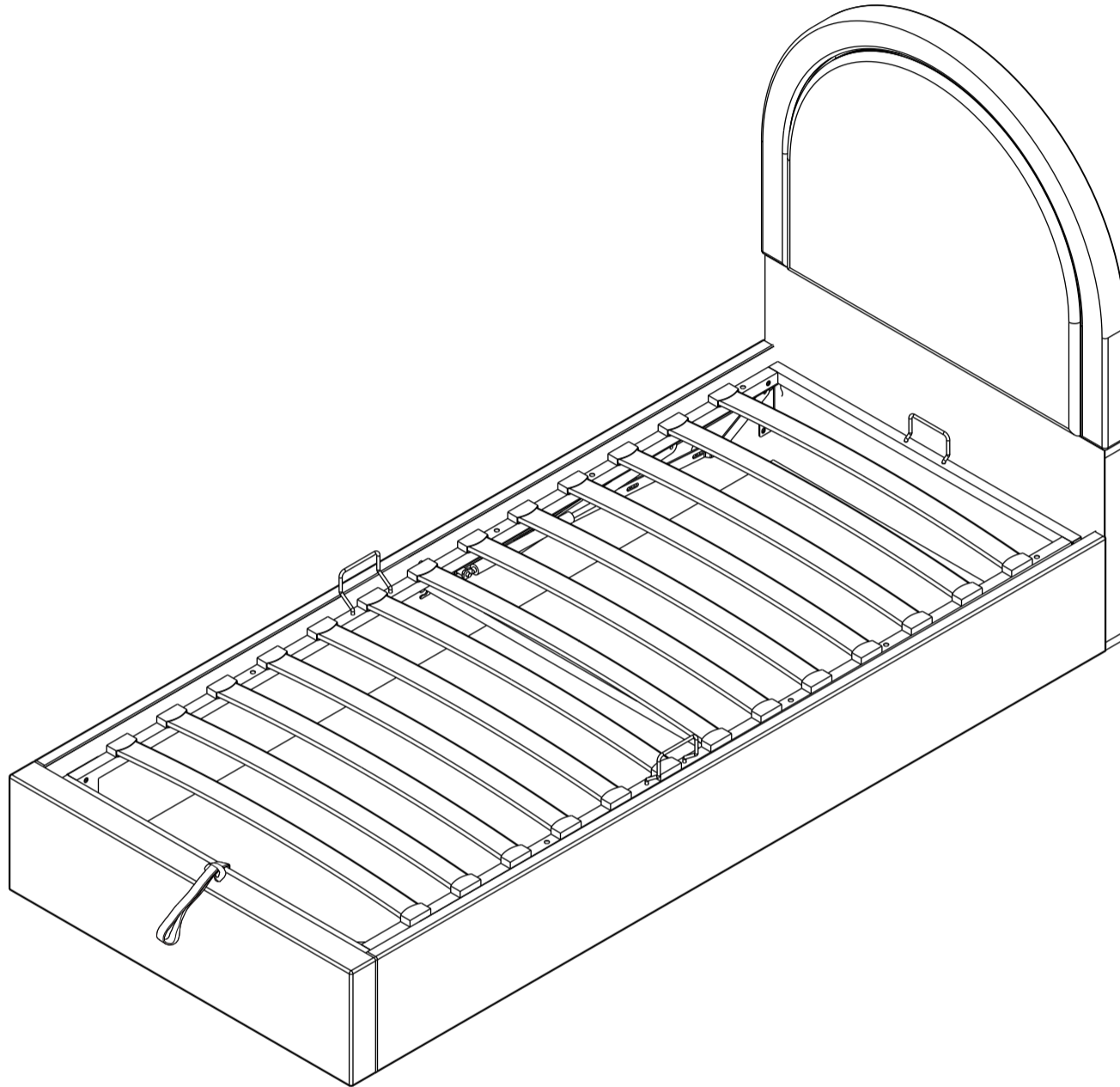

GB This set comes in 2 boxes. If you do not receive a full set of 2 boxes, please contact our customer service.

DE Dieses Set wird in 2 Schachteln geliefert. Wenn Sie nicht ein komplettes Set von 2 Boxen erhalten, kontaktieren Sie bitte unseren Kundenservice.

FR Ce set est livré en 2 boîtes. Si vous ne recevez pas un jeu complet de 2 boîtes, veuillez contacter notre service clientèle.

English

IMPORTANT FOR GAS LIFT BEDS&MAINTAINCE

- Please place the mattress on top of the bed frame.
- Please do not pull on the strap handles.
- Please press heavily to release the compressed gas.
- Periodically check all screw & fixings to ensure they are secure.
- When moving your product, carefully lift into place.
- Wipe clean with a slightly damp cloth- please do not use abrasive chemicals or bleach.
- Do NOT allow children to operate the lift mechanism.
- Do NOT allow children near the lift base when operating the mechanism.
- Do NOT stand inside the bed or the internal storage base.
- Do NOT overload the internal storage base.
- DO NOT jump on the product or any of its parts.

Deutsch

WICHTIG FÜR GASLIFT-BETTEN&WARTUNG

- Bitte legen Sie die Matratze oben auf den Bettrahmen.
- Bitte ziehen Sie nicht an den Gurtgriffen.
- Bitte drücken Sie kräftig, um das komprimierte Gas freizusetzen.
- Überprüfen Sie regelmäßig alle Schrauben und Befestigungen, um sicherzustellen, dass sie sicher sind.
- Wenn Sie Ihr Produkt bewegen, heben Sie es vorsichtig an seinen Platz.
- Mit einem leicht feuchten Tuch abwischen - bitte keine scheuernden Chemikalien oder Bleichmittel verwenden.
- Erlauben Sie Kindern NICHT, den Hebemechanismus zu bedienen.
- Lassen Sie Kinder NICHT in die Nähe des Liftsockels, wenn Sie den Mechanismus bedienen.
- Stellen Sie sich NICHT in das Bett oder in die Innenablage.
- Überlasten Sie den internen Liftsockel NICHT.
- Springen Sie NICHT auf das Produkt oder eines seiner Teile.

Français

IMPORTANT POUR LES LITS À RELEVAGE DE GAZ&MAINTENANCE

- Veuillez placer le matelas sur le dessus du cadre de lit.
- Ne tirez pas sur les poignées de la sangle.
- Appuyez fortement pour libérer le gaz comprimé.
- Vérifiez régulièrement que toutes les vis et fixations sont bien en place.
- Lorsque vous déplacez votre produit, soulevez-le avec précaution pour le mettre en place.
- Nettoyez avec un chiffon légèrement humide - n'utilisez pas de produits chimiques abrasifs ou d'eau de Javel.
- Ne laissez pas les enfants utiliser le mécanisme de levage.
- Ne laissez pas les enfants s'approcher de la base de levage lorsqu'ils actionnent le mécanisme.
- Ne vous tenez PAS à l'intérieur du lit ou de la base de stockage interne.
- Ne surchargez pas la base de stockage interne.
- Ne pas sauter sur le produit ou l'une de ses parties.

Italiano

IMPORTANTE PER I LETTI CON SOLLEVAMENTO A GAS E LA MANUTENZIONE

- Posizionare il materasso sopra la struttura del letto.
- Non tirare le maniglie della cinghia.
- Premere con forza per rilasciare il gas compresso.
- Controllare periodicamente tutte le viti e i fissaggi per assicurarsi che siano saldi.
- Quando si sposta il prodotto, sollevarlo con cautela.
- Pulire con un panno leggermente umido, senza usare prodotti chimici abrasivi o candeggina.
- NON permettere ai bambini di azionare il meccanismo di sollevamento.
- NON permettere ai bambini di avvicinarsi alla base di sollevamento quando si aziona il meccanismo.
- NON sostare all'interno del letto o della base di contenimento interna.
- NON sovraccaricare la base di contenimento interna.
- NON saltare sul prodotto o sulle sue parti.

Español

IMPORTANTE PARA LAS CAMAS ELEVADORAS DE GAS & MANTENIMIENTO

- Coloque el colchón sobre el somier.
- No tire de las asas de la correa.
- Presione con fuerza para liberar el gas comprimido.
- Compruebe periódicamente que todos los tornillos y fijaciones estén bien sujetos.
- Al mover el producto, levántelo con cuidado para colocarlo en su sitio.
- Limpie con un paño ligeramente humedecido; no utilice productos químicos abrasivos ni lejía.
- NO permita que los niños accionen el mecanismo de elevación.
- NO permita que los niños se acerquen a la base elevadora cuando accionen el mecanismo.
- NO se ponga de pie dentro de la cama o de la base de almacenamiento interna.
- NO sobrecargue el somier.
- NO salte sobre el producto ni sobre ninguna de sus piezas.



Stückliste

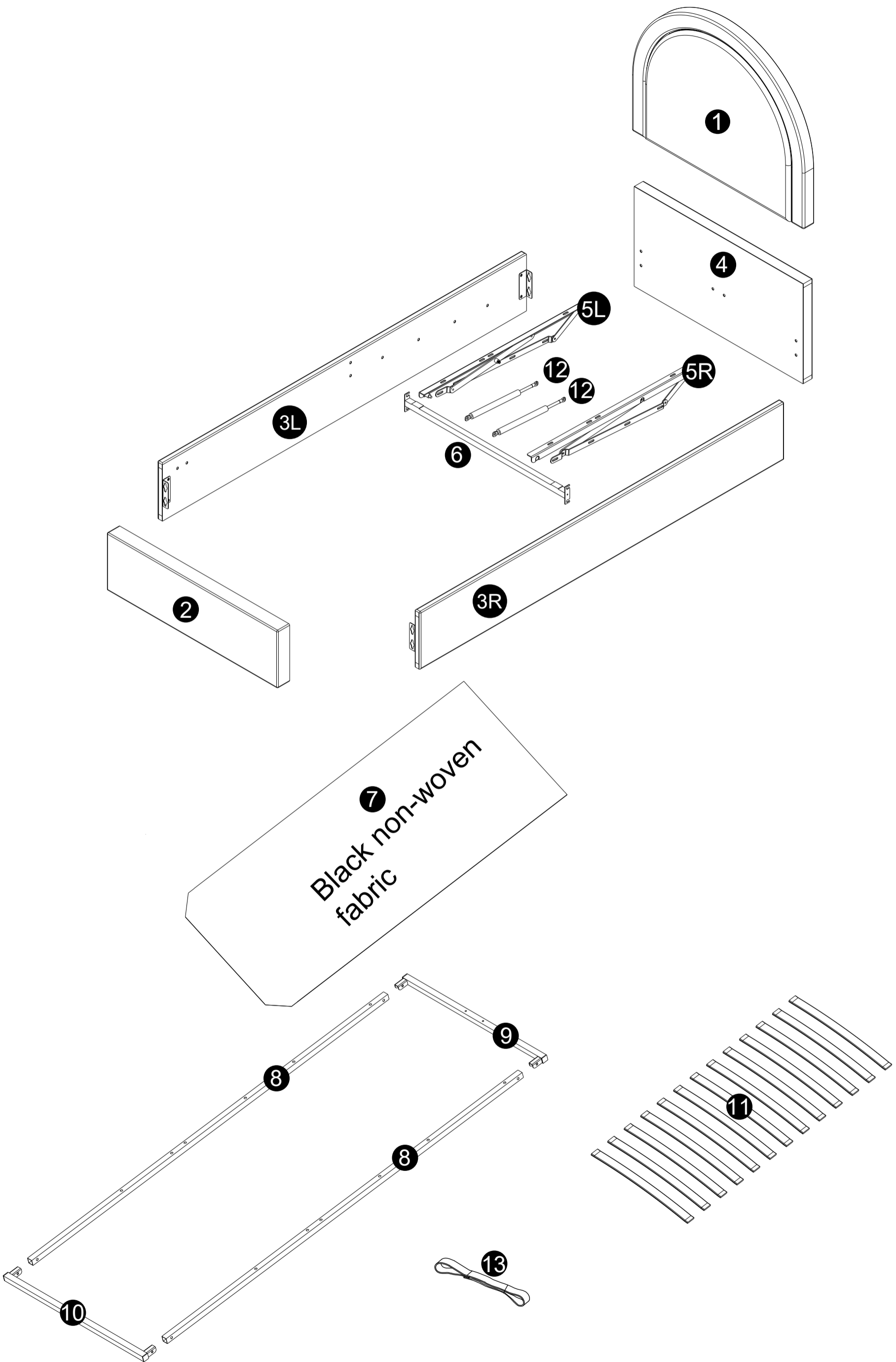

N616P228368/N616P228370

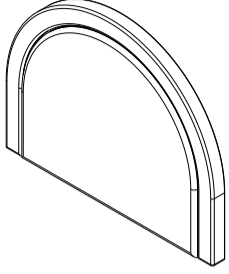
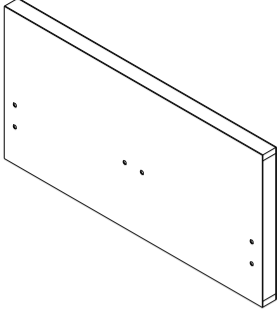
<p>1</p>		<p>X1</p>	<p>4</p>		<p>X1</p>
----------	---	-----------	----------	--	-----------

N616P228369/N616P228371

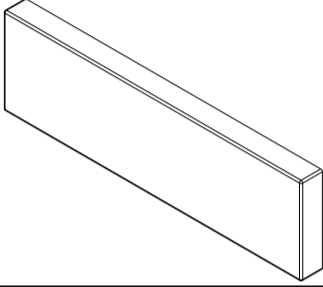
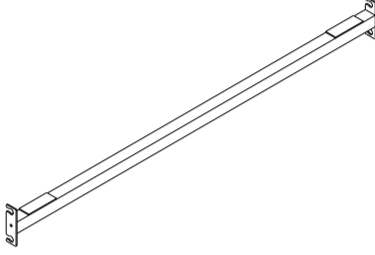
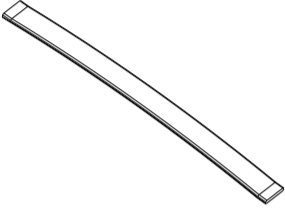
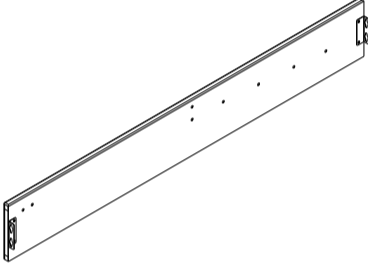
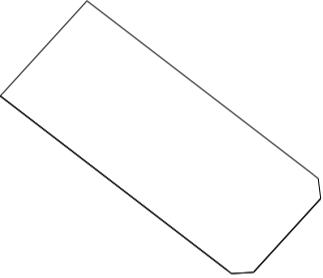
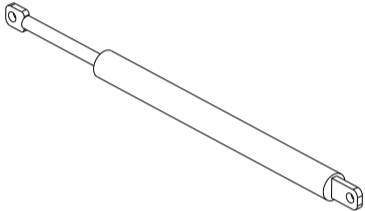
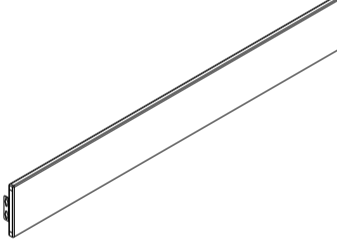
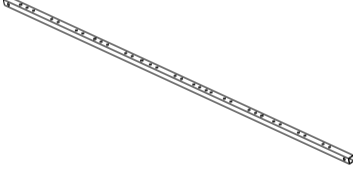
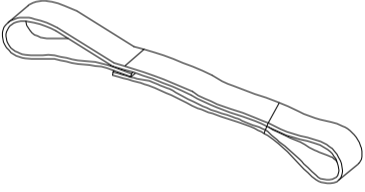
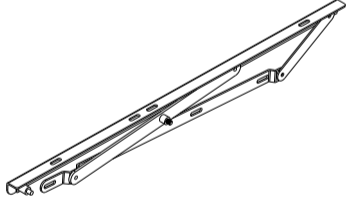
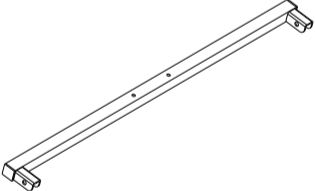
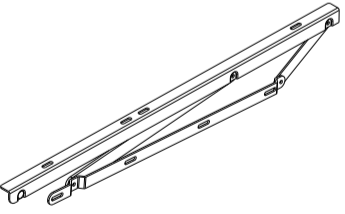
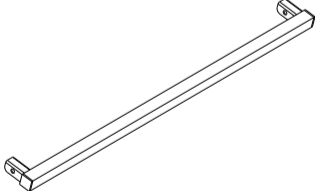
<p>2</p>		<p>X1</p>	<p>6</p>		<p>X1</p>	<p>11</p>		<p>X13</p>
<p>3L</p>		<p>X1</p>	<p>7</p>		<p>X1</p>	<p>12</p>		<p>X2</p>
<p>3R</p>		<p>X1</p>	<p>8</p>		<p>X2</p>	<p>13</p>		<p>X1</p>
<p>5L</p>		<p>X1</p>	<p>9</p>		<p>X1</p>			
<p>5R</p>		<p>X1</p>	<p>10</p>		<p>X1</p>			

Hardware List-Hardware-Liste-Liste du matériel

N616P228368/N616P228370

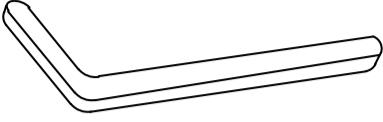
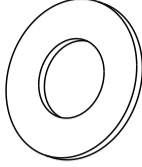
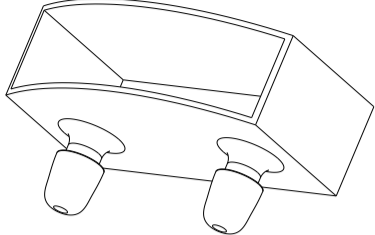
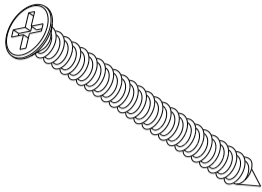
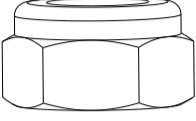
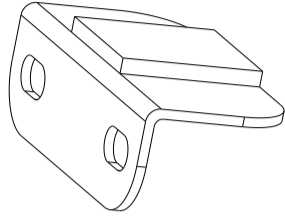
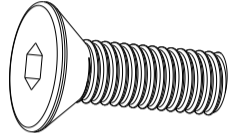
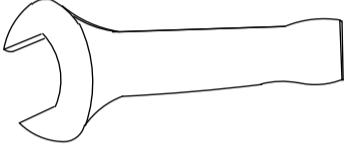
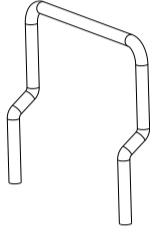
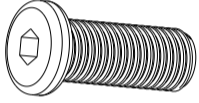
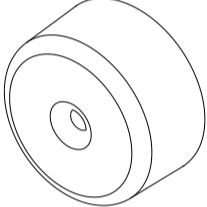
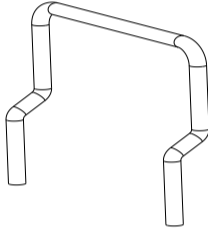
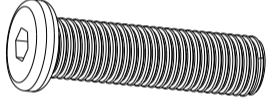
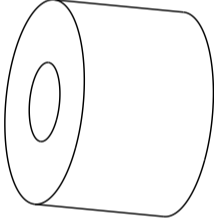
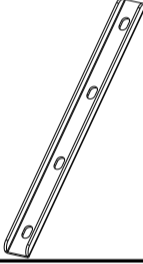
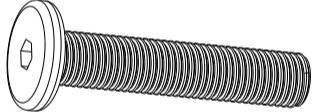
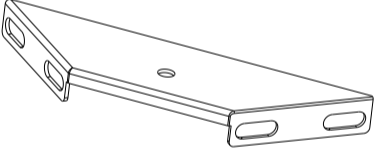
A		X1	G		X4	N		X26
B	 M4x40mm	X4	H	 M8	X14	P		X2
C	 M8x18mm	X4	J		X1	Q		X1
D	 M8x20mm	X28	K		X4	R		X2
E	 M8x30mm	X8	L		X8	U		X2
F	 M8x40mm	X10	M		X2			

1

A x 1



B x 4



M4 x 40mm

D x 8

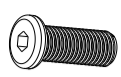

M8 x 20mm

K x 4

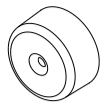

U x 2

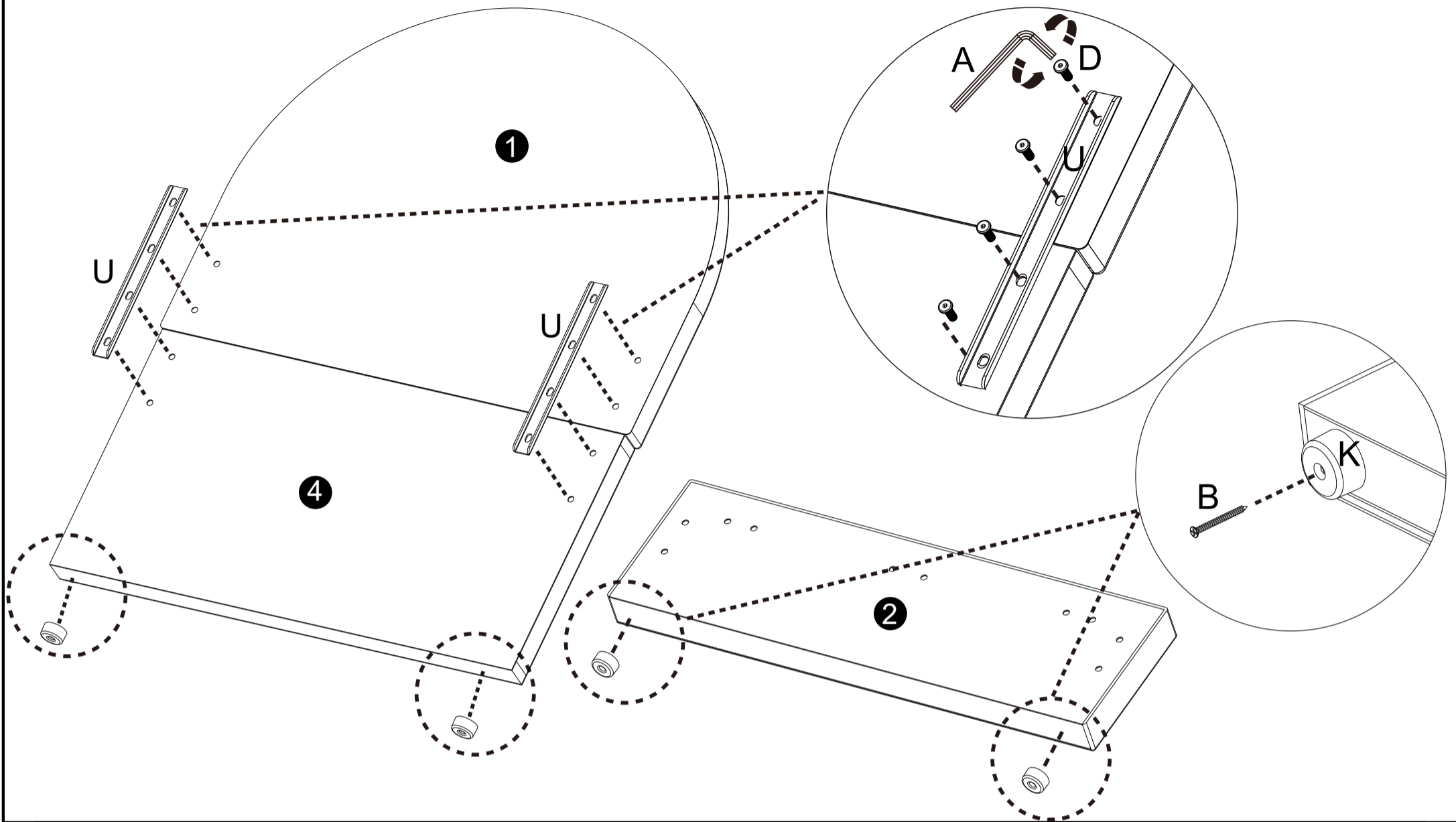
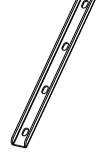
**2**

A x 1



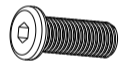

D x 4





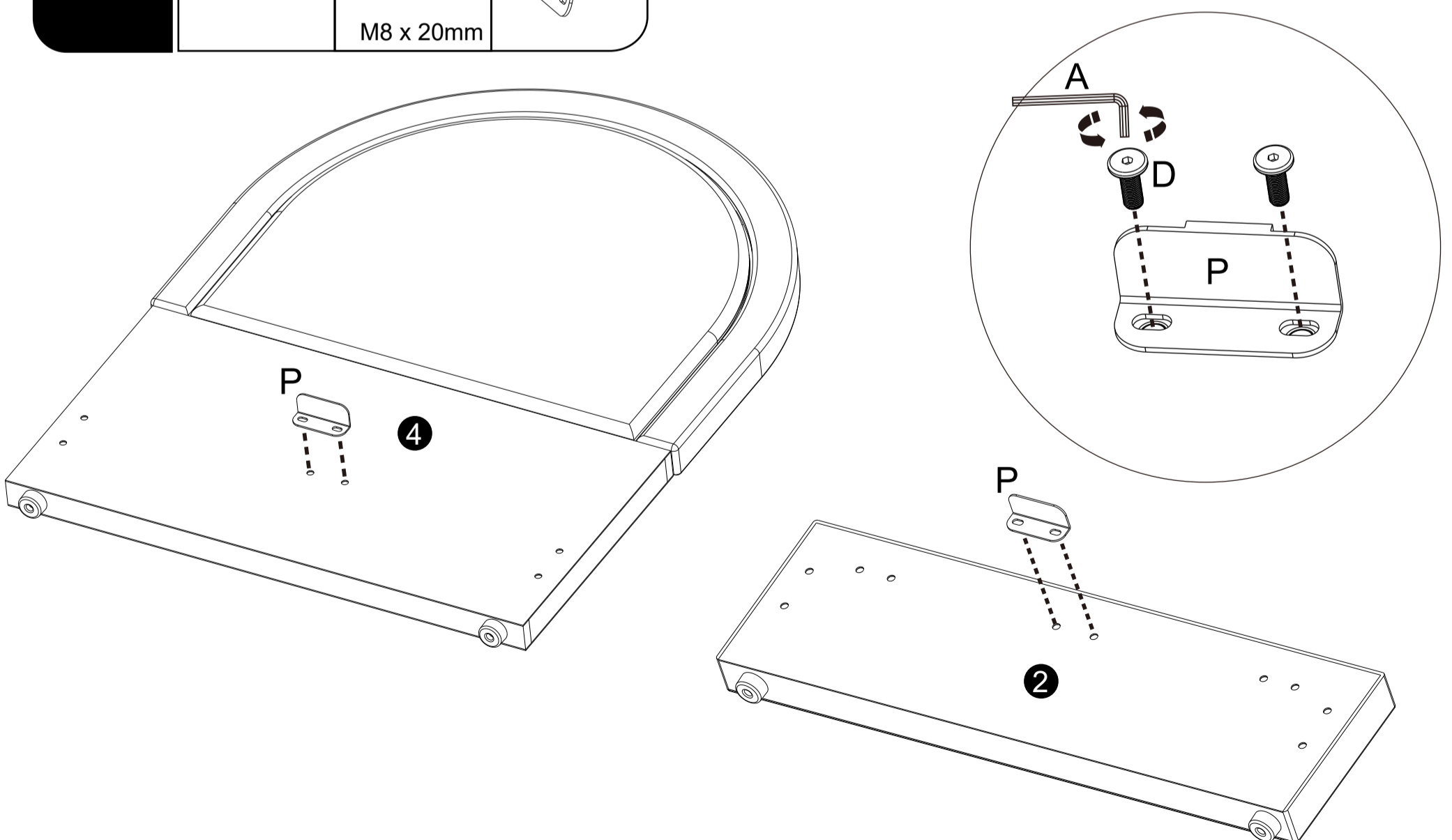
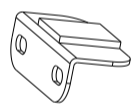

M8 x 20mm

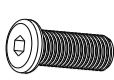
P x 2

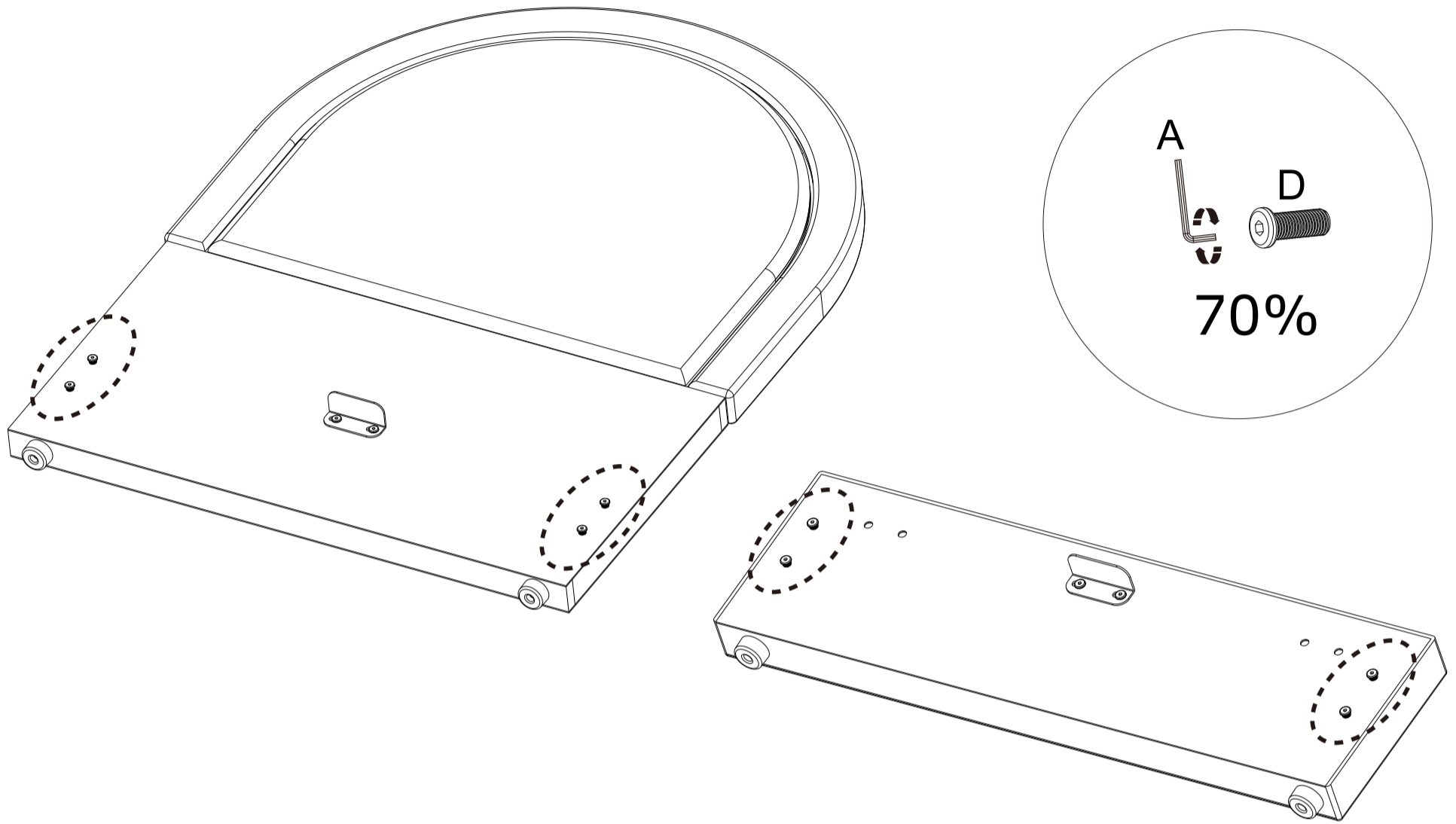

3	A x 1	D x 8
		 M8 x 20mm



4	A x 1	E x 8	L x 8
		 M8 x 30mm	

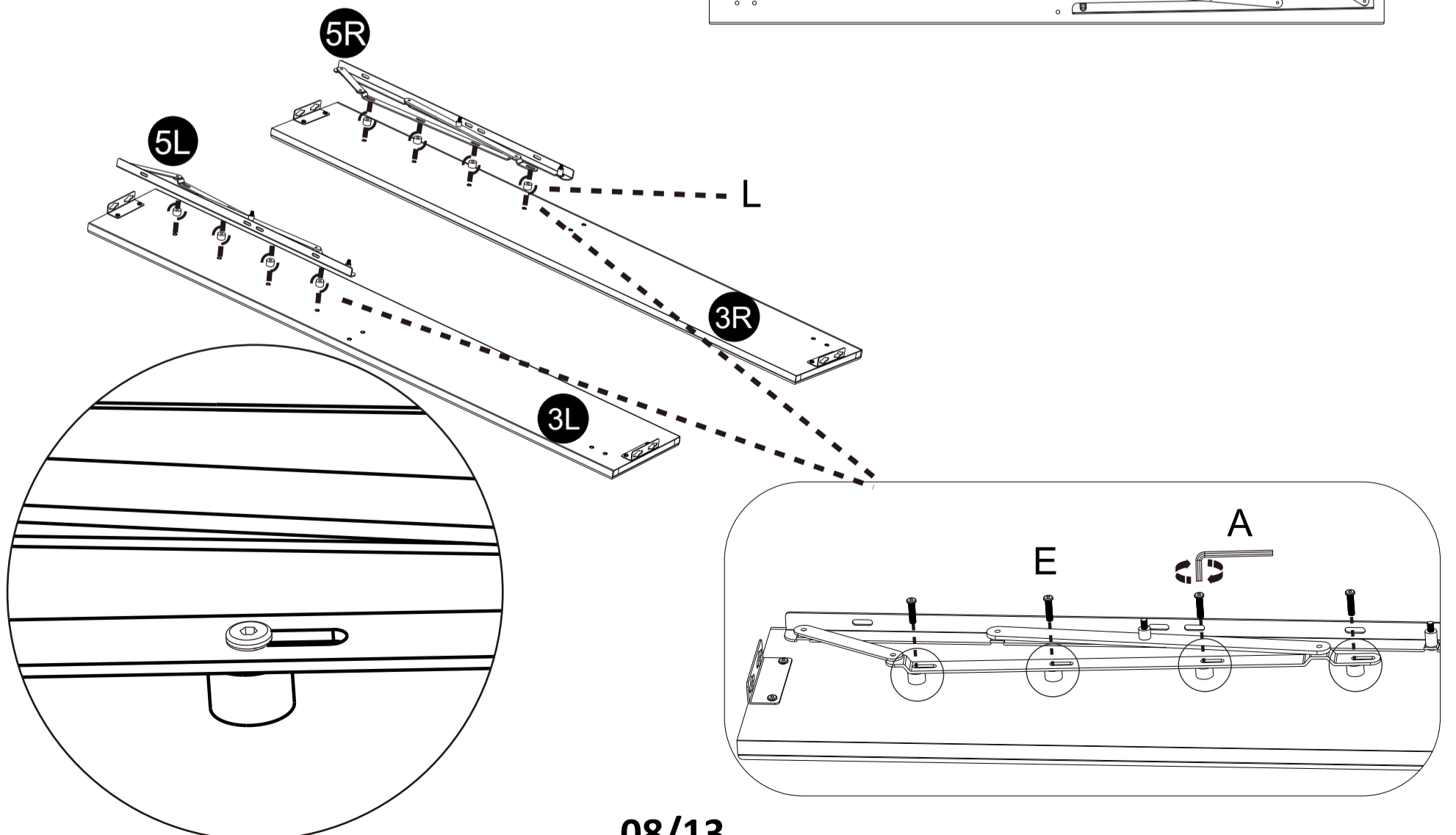
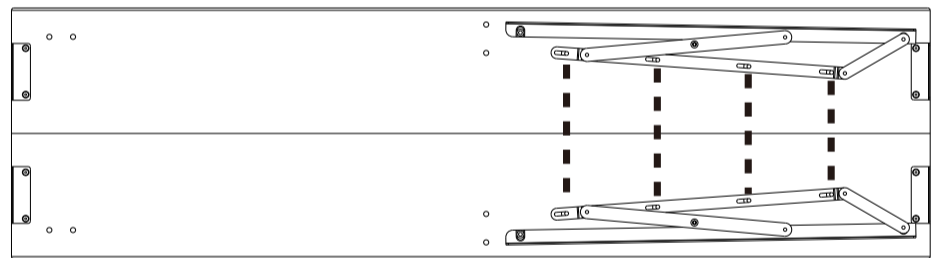



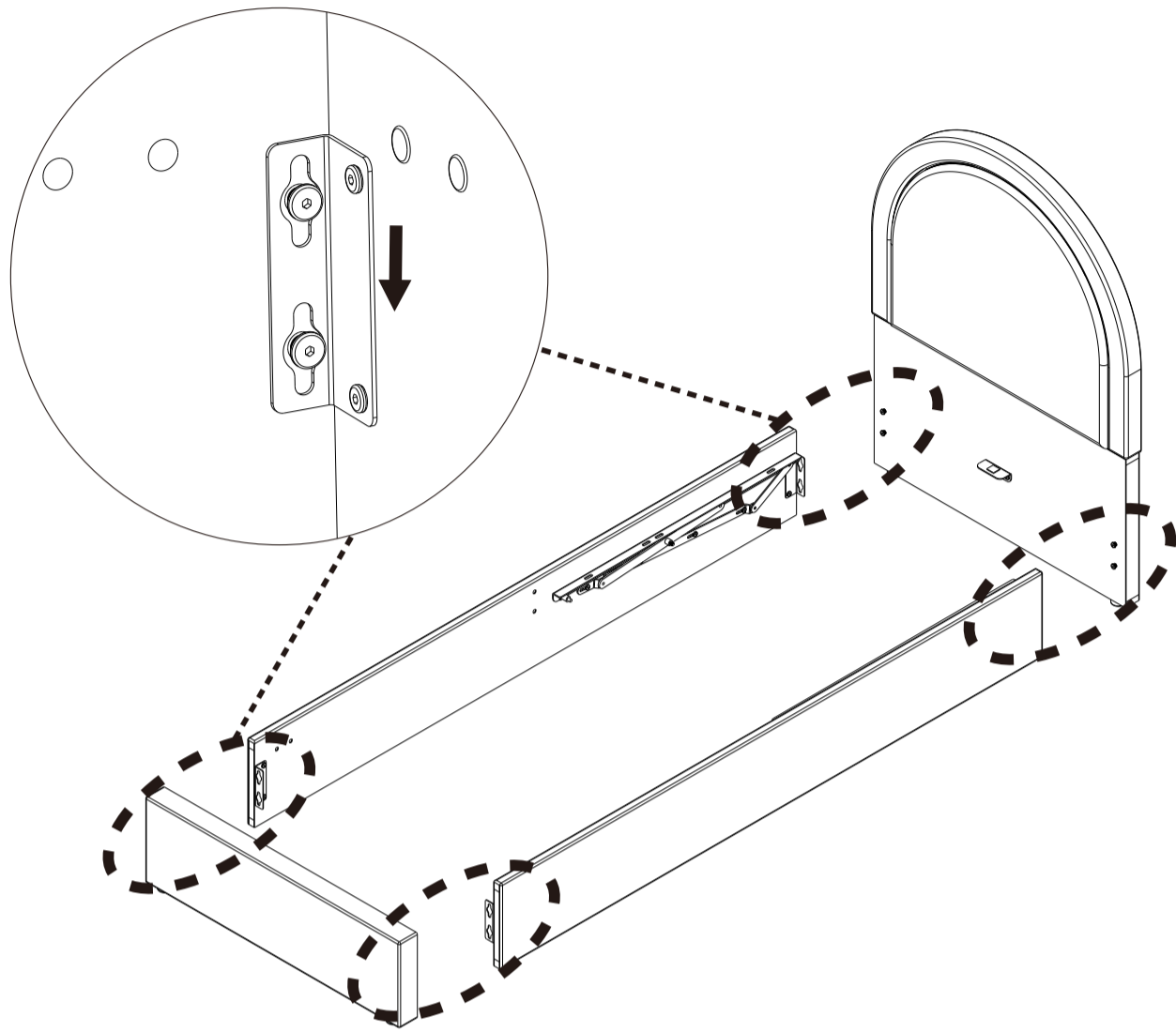

5 Ax 1



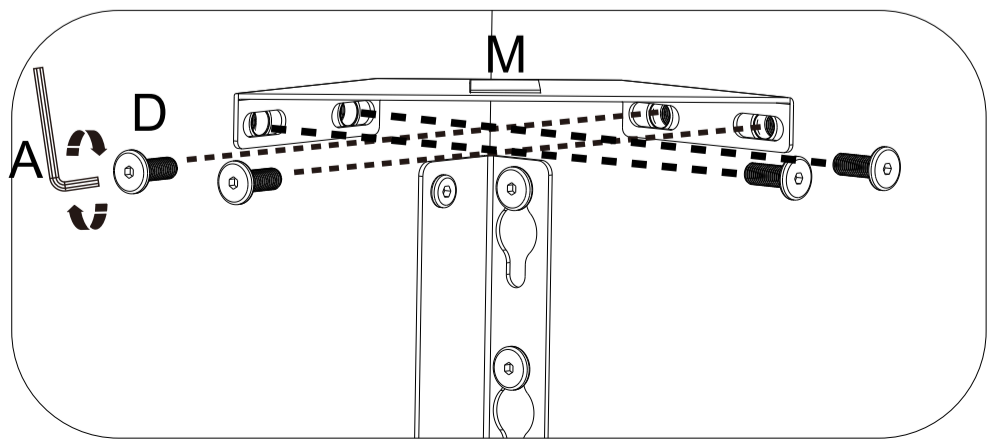
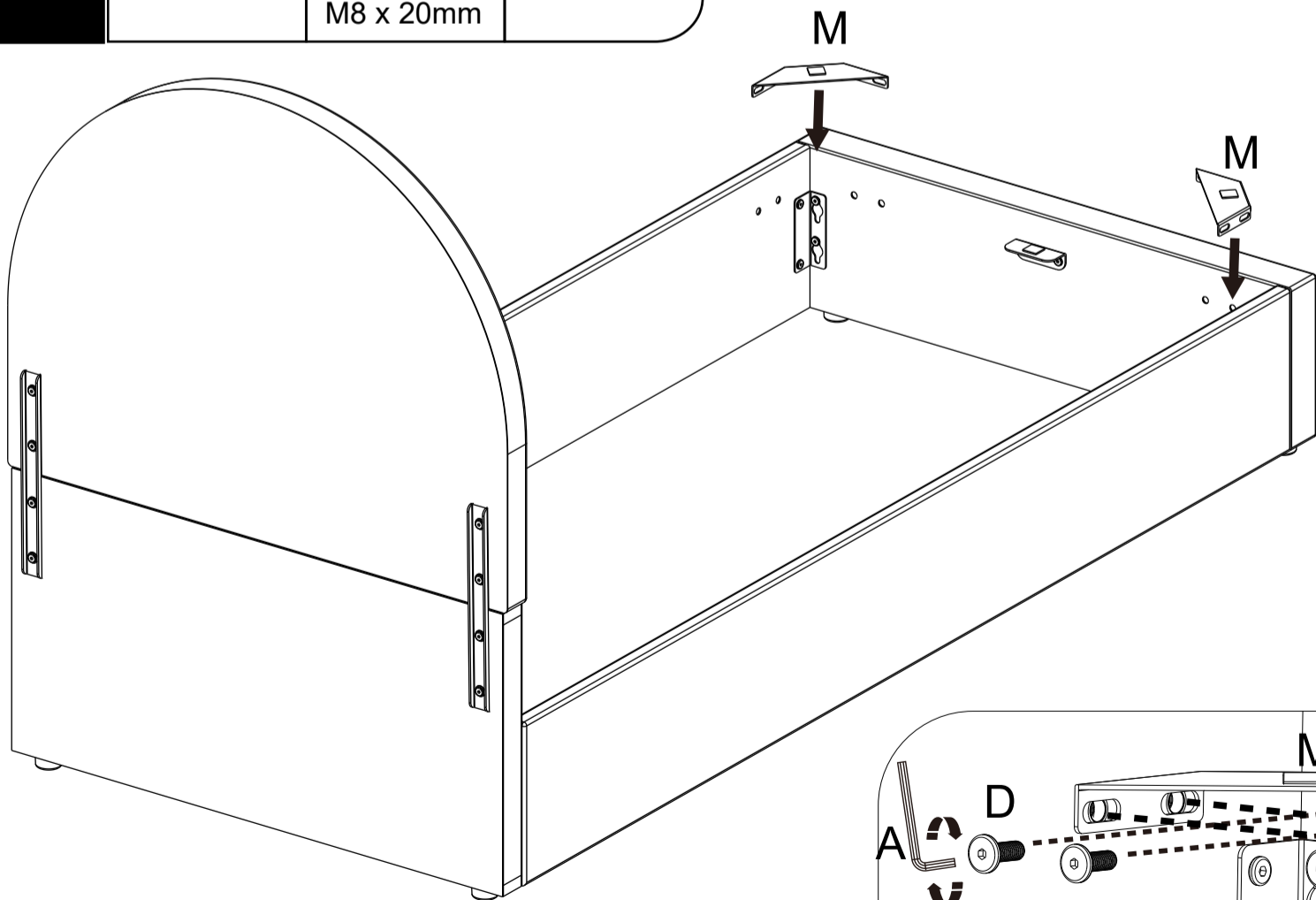

A D
100%

6 Ax 1 D x 8 M x 2
M8 x 20mm

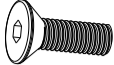
7	A x 1	C x 4
		 M8 x 18mm

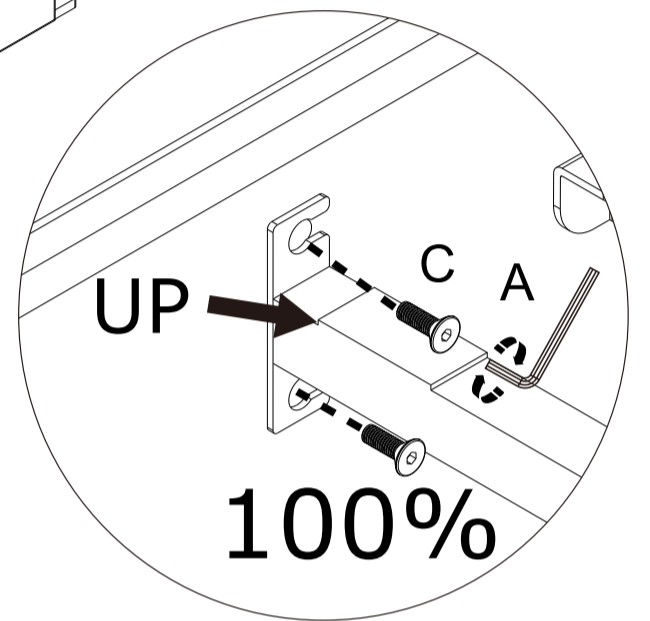
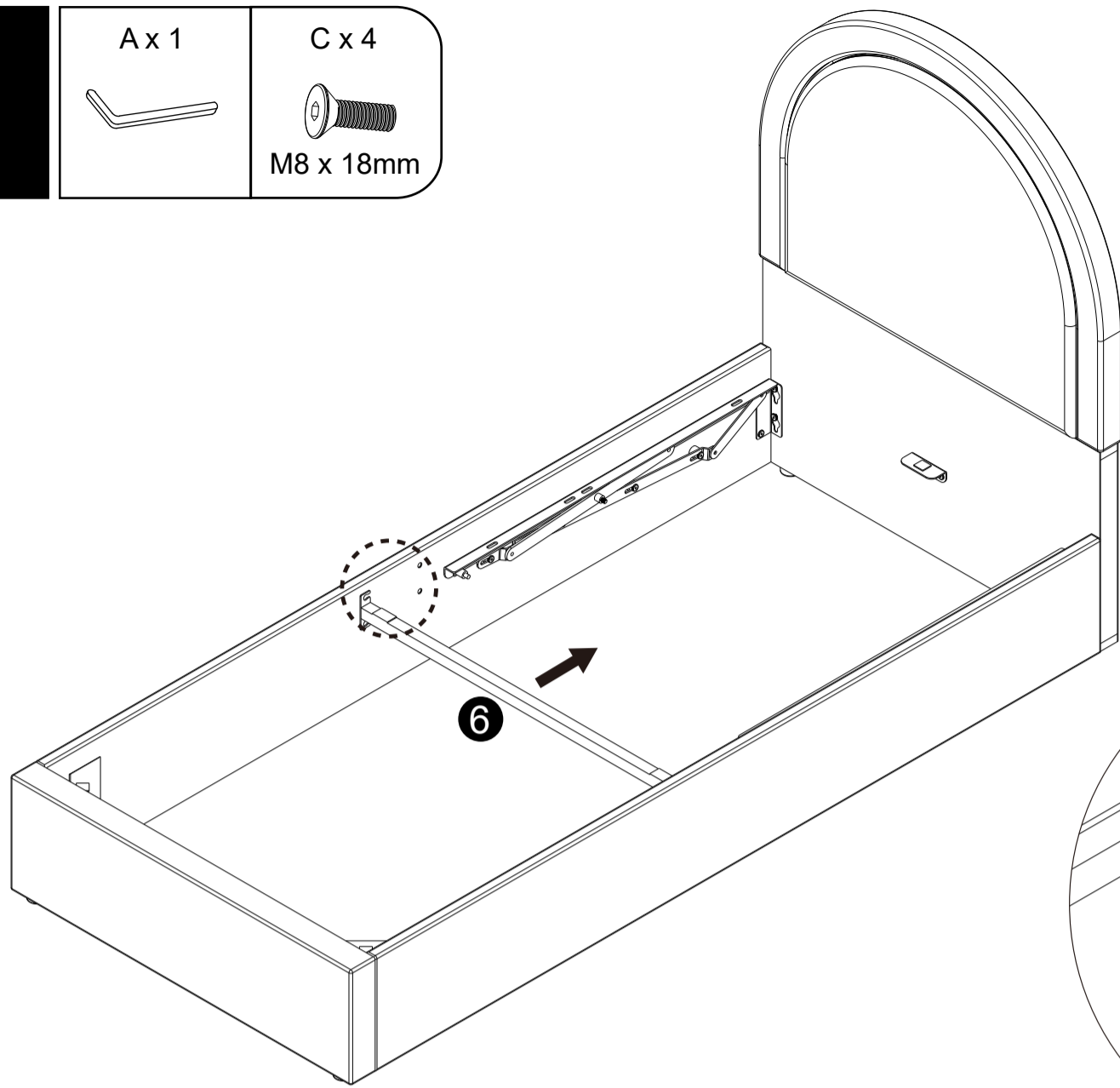

8

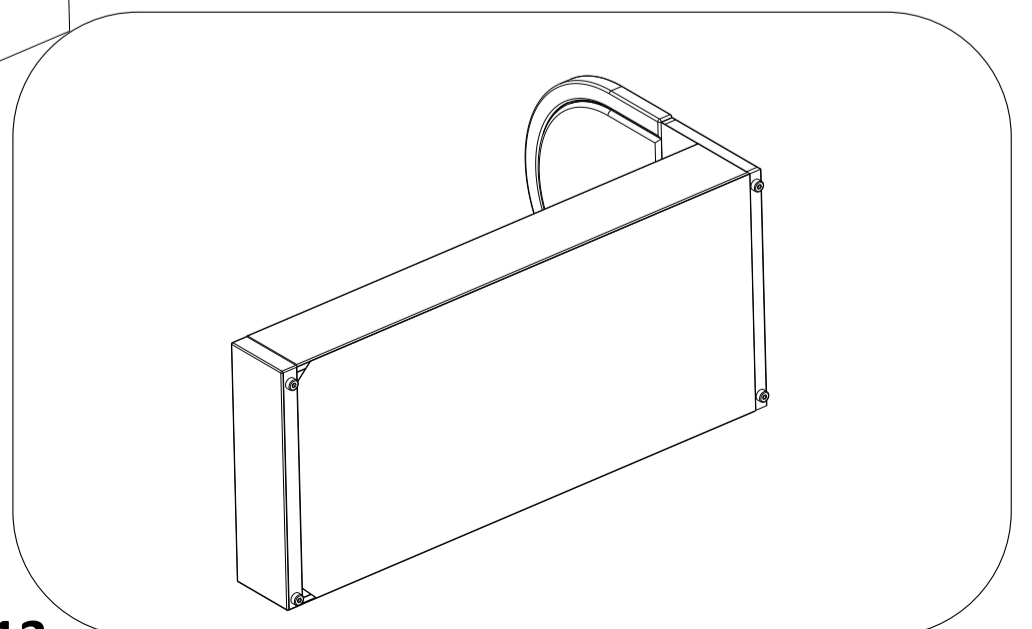
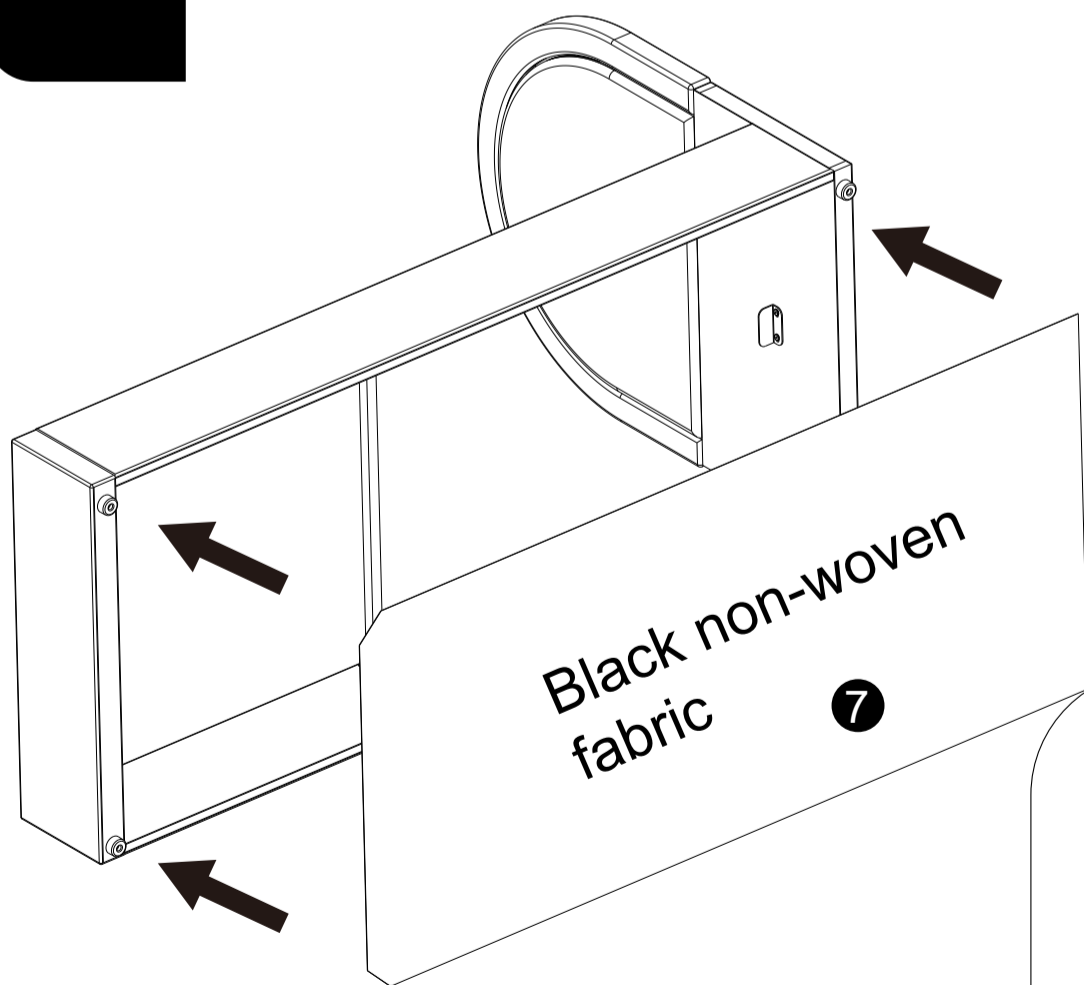

9

A x 1



F x 4



M8 x 40mm

G x 4

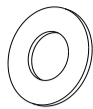

H x 4

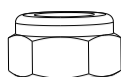

J x 1

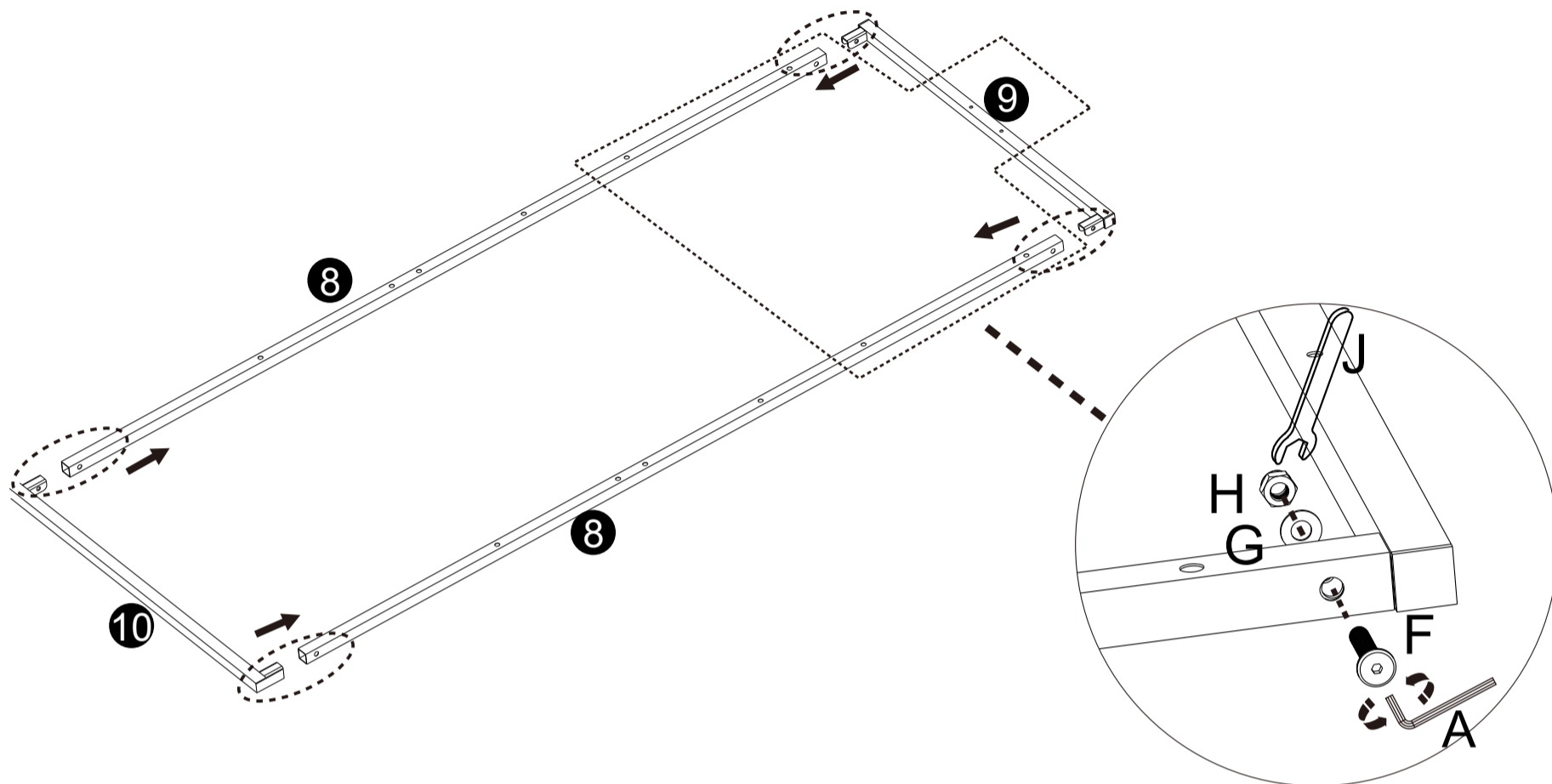

!!! Please aware the orientation of the holes on #8
 !!!Bitte beachten Sie die Ausrichtung der Löcher auf #8
 !!! Attention à l'orientation des trous sur le #8

**10**

A x 1



F x 6



M8 x 40mm

H x 6

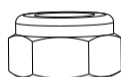

J x 1



Q x 1

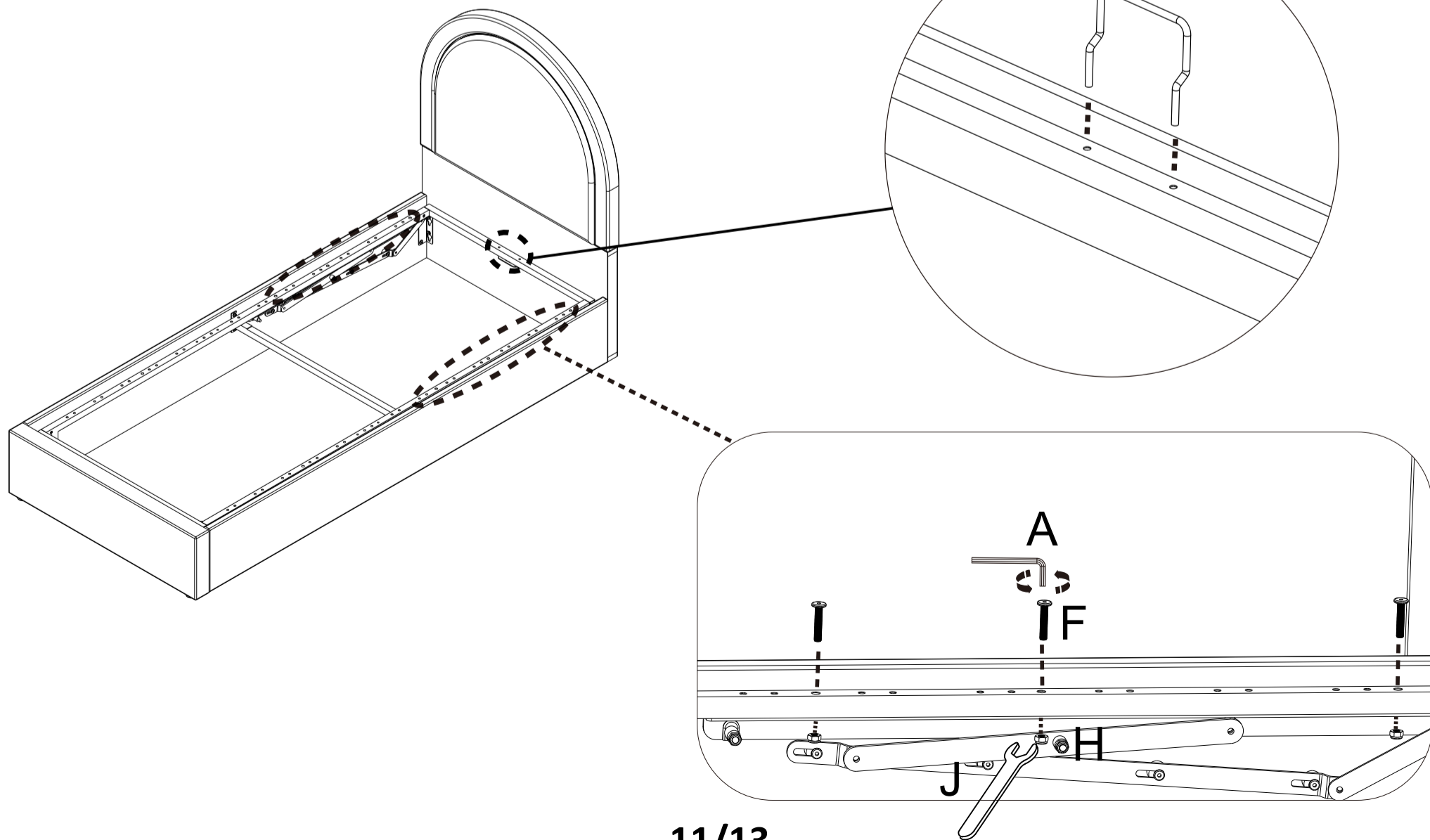

11 N x 26

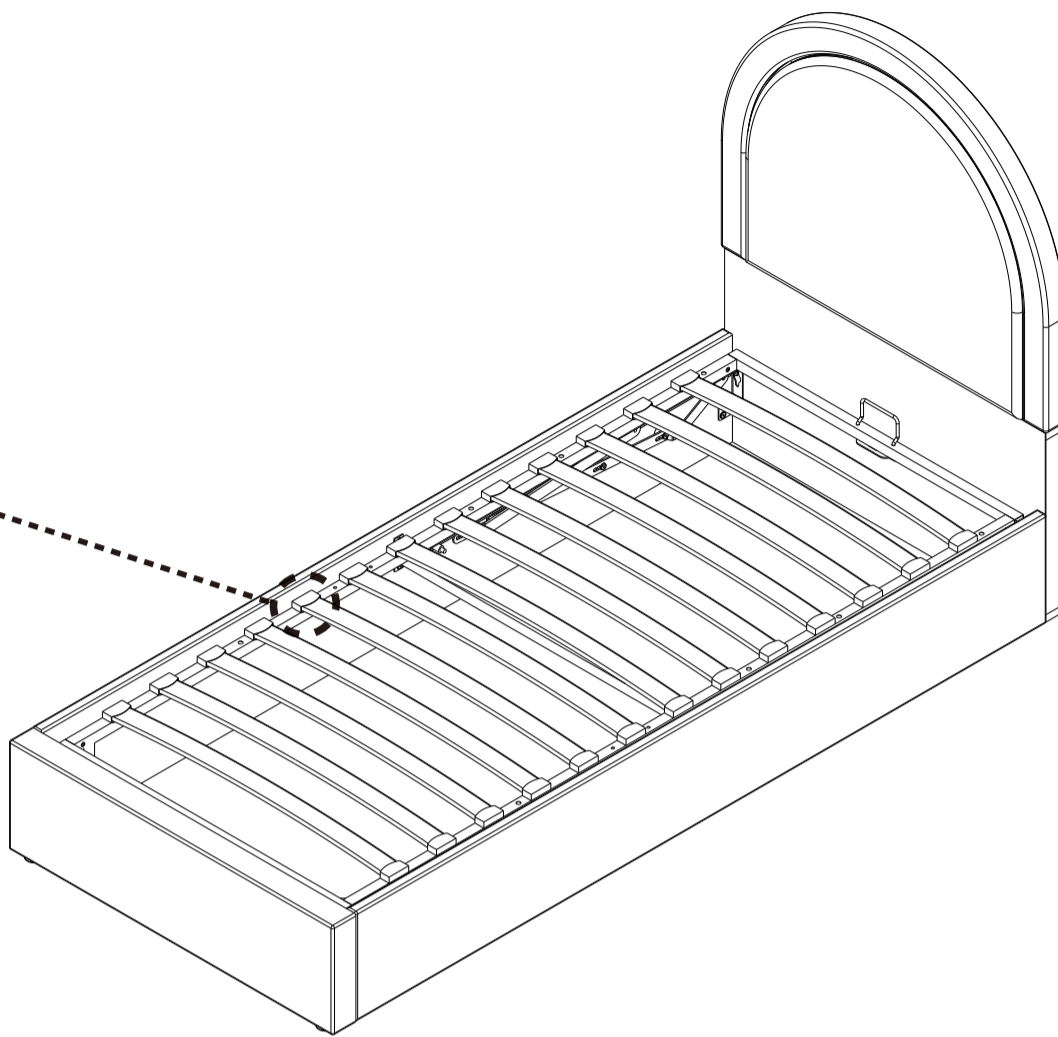
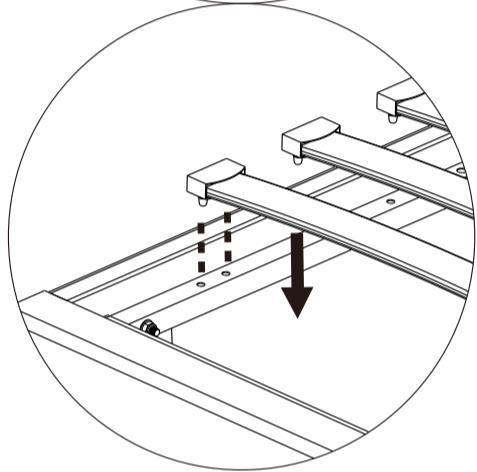
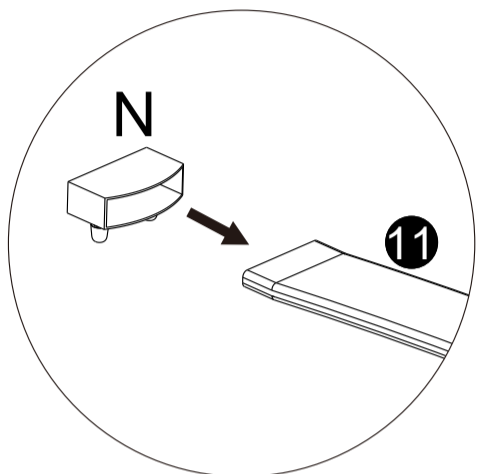
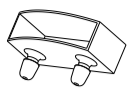

12 R x 2

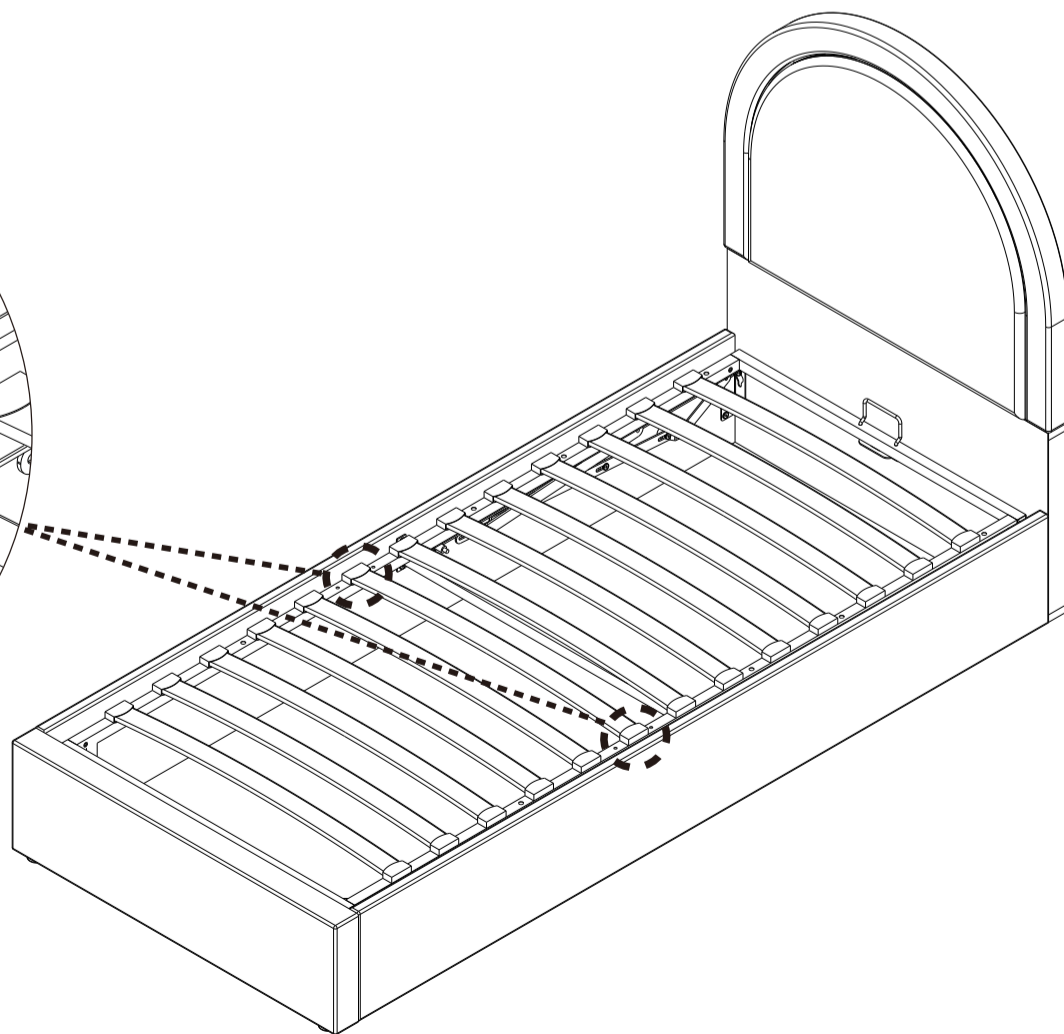
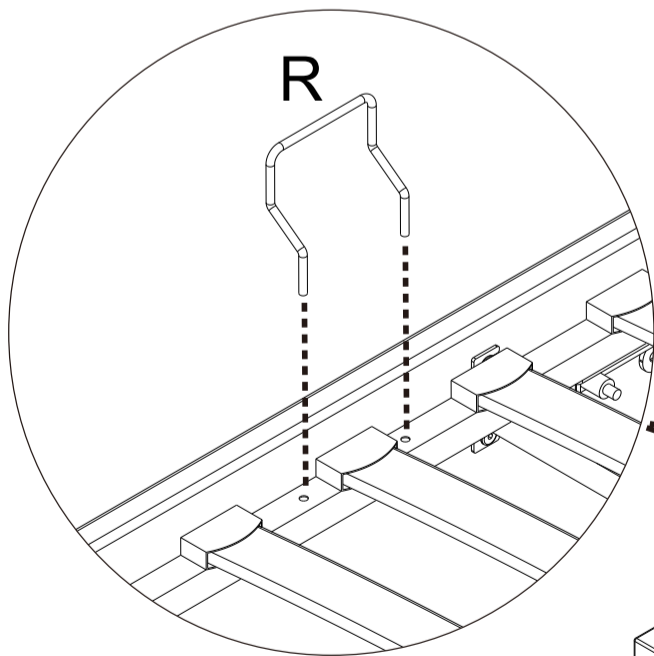
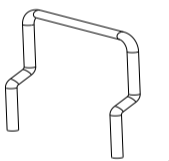

13

H x 4

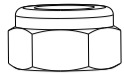

J x 1

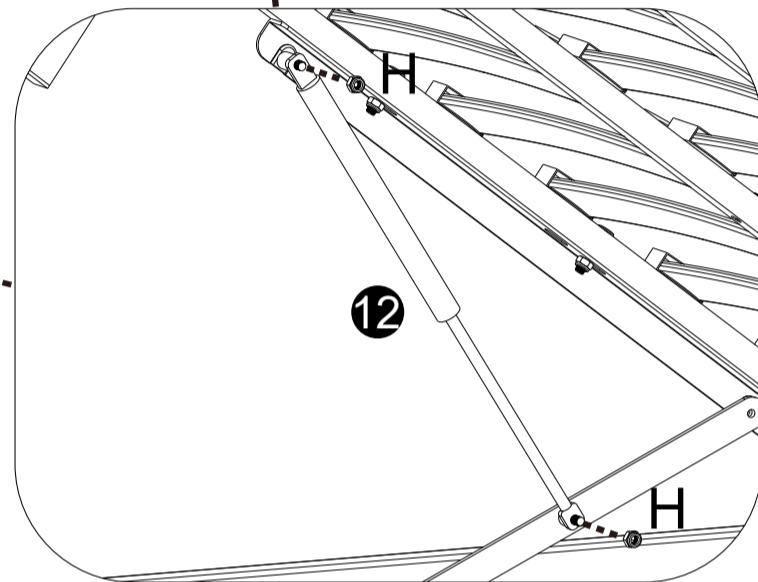
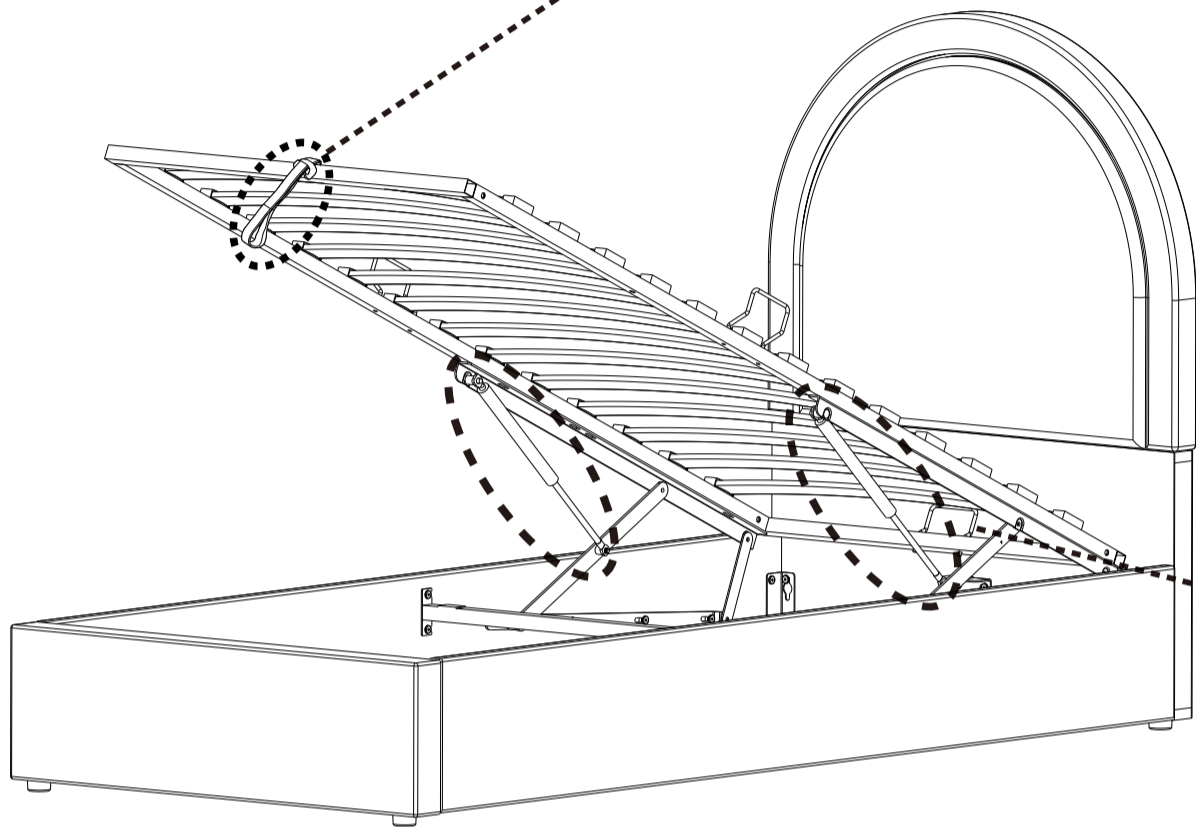
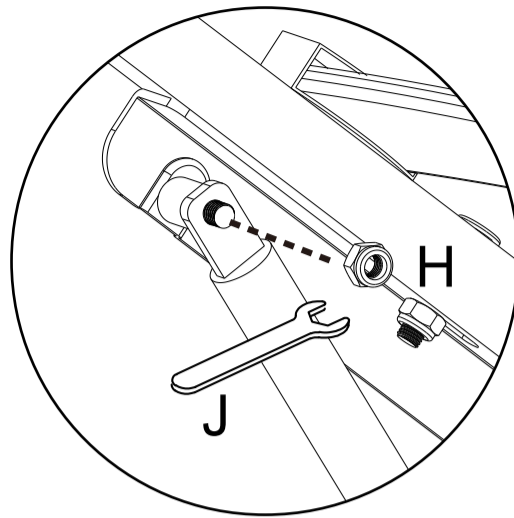
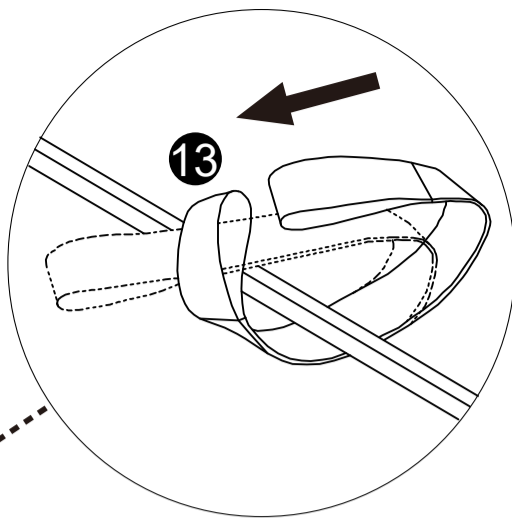

14

