

CALYPSO

WATCHES

IKMK5807M

MANUAL DE INSTRUCCIONES

INSTRUCTION MANUAL

MANUEL D'INSTRUCTION

BETRIEBSANLEITUNG

MANUALE DI FUNZIONAMENTO

MANUAL DE INSTRUÇÕES

MODO DE VISUALIZACIÓN Y OPERACIÓN DE LOS BOTONES

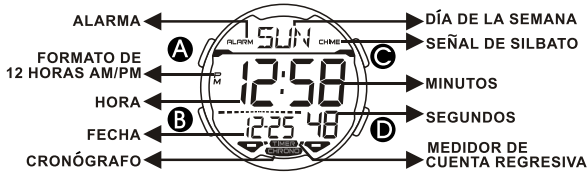

OPERACION DE BOTON

- A AJUSTE / RECUPERAR
- B MODO
- C AVANZAR / INICIO / VUELTA/PARCIAL
- D RETIRARSE / PARADA / AJUSTE / LUZ

CUIDADO DE SU RELOJ

- Este reloj contiene componentes electrónicos. No intente abrir la caja o remover la tapa posterior.
- No oprimir los botones de su reloj bajo la superficie del agua, nadando o practicando submarinismo.
- Si por cualquier motivo llegase a aparecer agua o condensación en el reloj hágalo chequear inmediatamente. El agua puede corroer los componentes electrónicos dentro de la caja.
- Evite impactos severos. El reloj está diseñado para resistir impactos bajo condiciones normales de uso. Se sugiere no someterlo a impactos severos, al uso inadecuado o caídas bruscas sobre superficies duras.
- Evite exponer el reloj a temperaturas extremas.
- Limpié su reloj únicamente con agua y un paño suave. Evite el uso de productos químicos especialmente de jabón.
- Mantenga su reloj lejos de cualquier campo eléctrico o estático.

COMO CAMBIAR EL MODO DE VISUALIZACIÓN

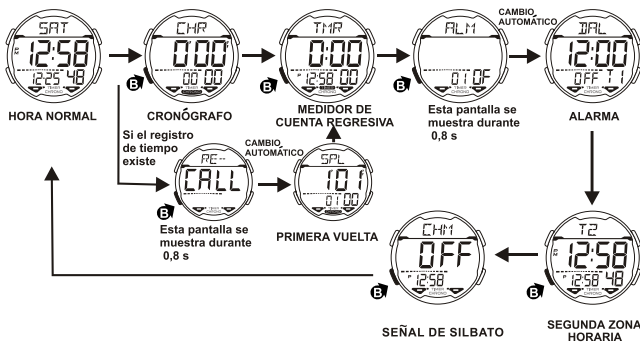

COMO VISUALIZAR EL MES Y LA FECHA

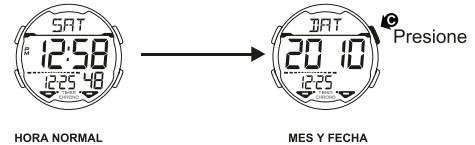

AJUSTE DE LA HORA NORMAL

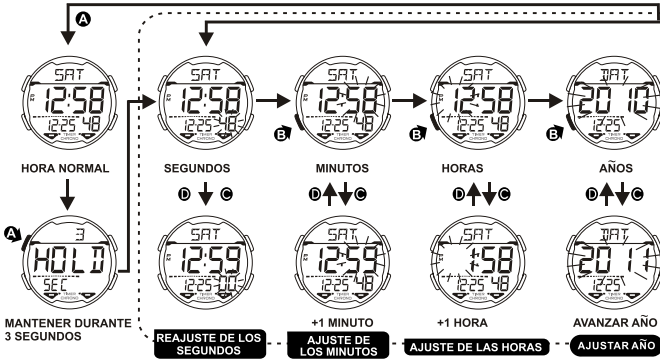

AJUSTE DE LA HORA NORMAL

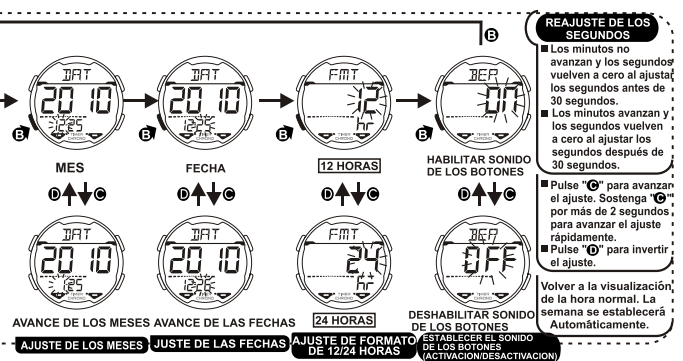

COMO UTILIZAR EL CRONÓGRAFO

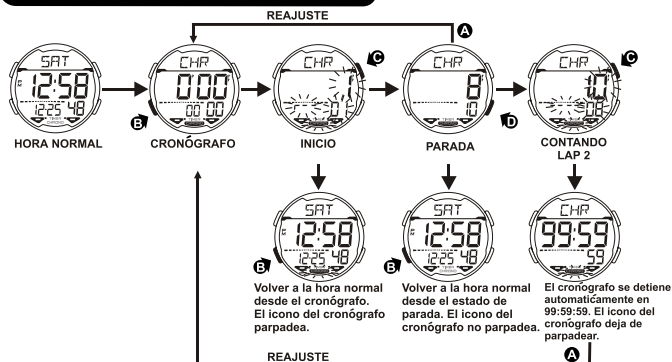

COMO CAMBIAR EL MODO VUELTA/PARCIAL

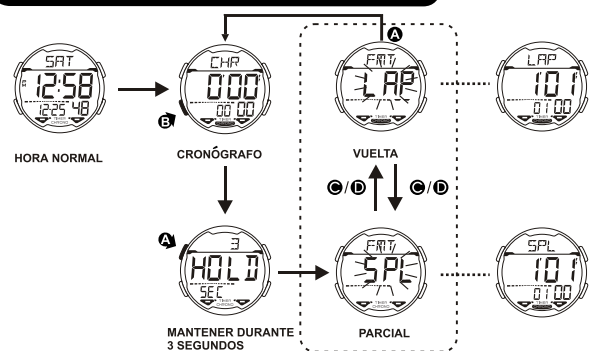

COMO AJUSTAR OPERACIÓN DE SPLIT Y LAP

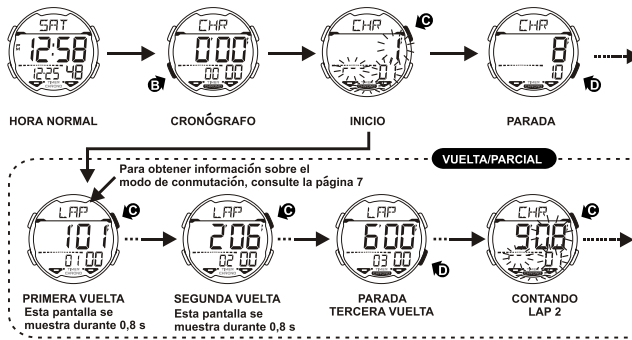

COMO AJUSTAR OPERACIÓN DE SPLIT Y LAP

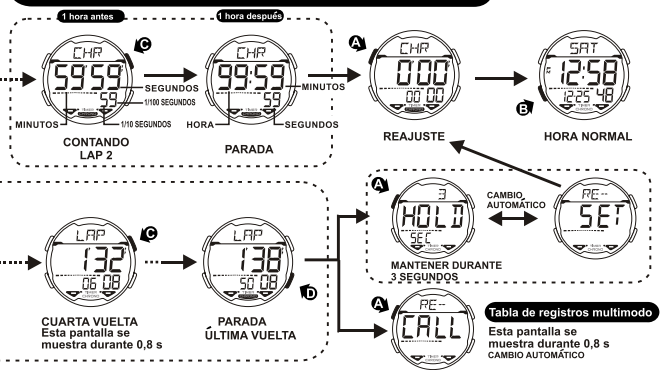

COMO UTILIZAR LA FUNCIÓN DE RECUPERACIÓN

COMO UTILIZAR LA FUNCIÓN DE RECUPERACIÓN

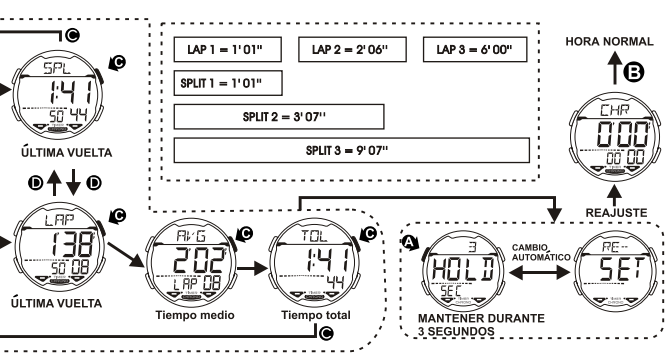
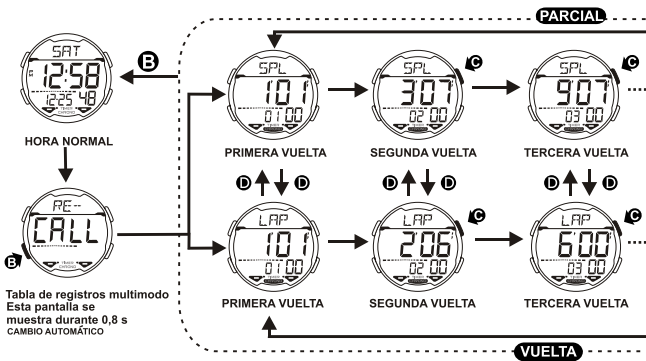

COMO UTILIZAR EL MEDIDOR DE CUENTA REGRESIVA

COMO UTILIZAR EL MEDIDOR DE CUENTA REGRESIVA

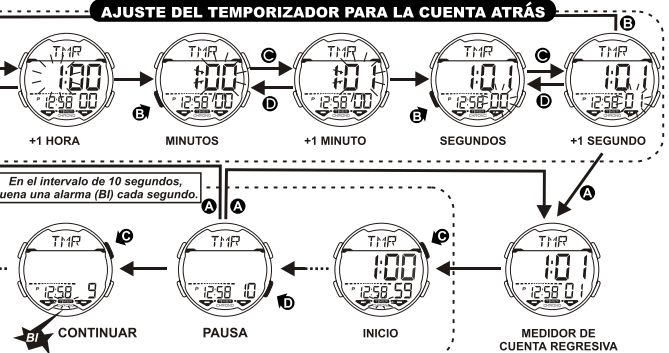
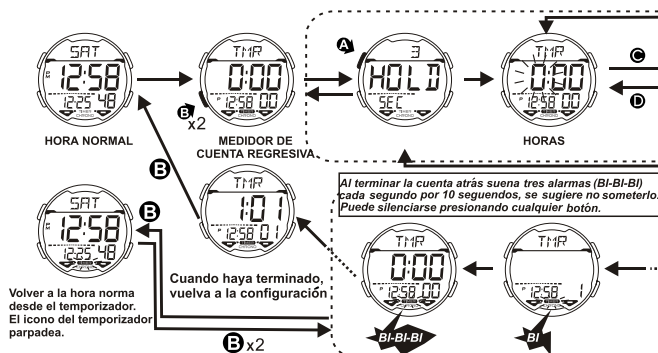

CÓMO ESTABLECER LA HORA DE LA ALARMA DIARIA

CÓMO ESTABLECER LA HORA DE LA ALARMA DIARIA

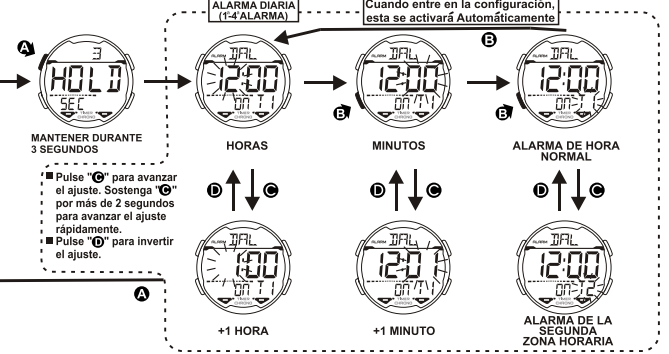
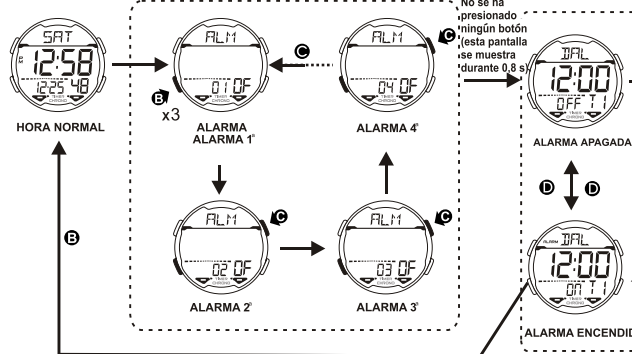

CÓMO ESTABLECER LA HORA DE LA ALARMA DIARIA

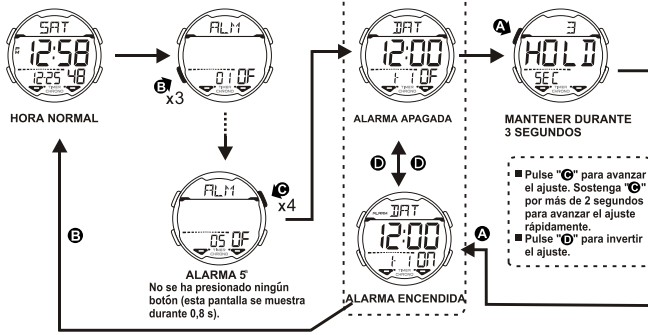

CÓMO ESTABLECER LA HORA DE LA ALARMA DIARIA

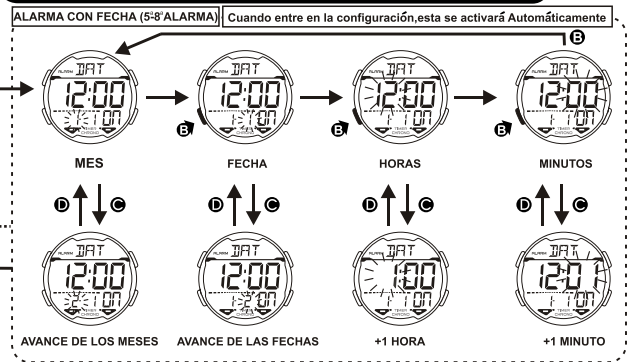

AJUSTE DE LA SEGUNDA ZONA HORARIA

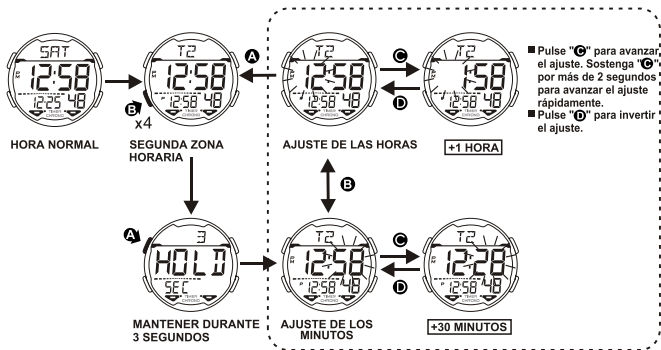

CÓMO ACTIVAR Y DESACTIVAR EL SONIDO DE CADA HORA

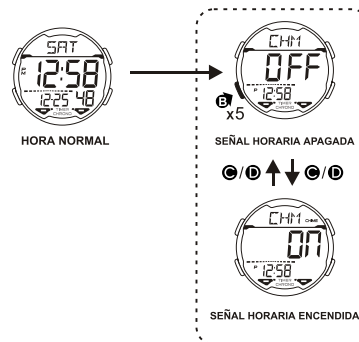

USO DE LA LUZ

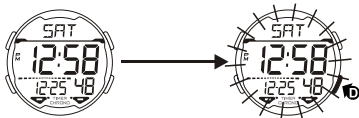

NOTAS:

1. La iluminación del reloj utiliza una luz electroluminiscente (EL) que tiende a perder potencia después de usos muy prolongados.
2. Bajo la luz solar directa es difícil ver la iluminación que proporciona la luz de la pantalla.

SONIDO

1. Sonido de los botones: ACTIVAR o DESACTIVAR. Consulte la sección "Cómo establecer la visualización de funciones".
2. Pitidos cada vez que se presiona un botón, excepto el botón LIGHT.
3. El botón solamente pitará una vez cuando se presione y se mantenga pulsado.
4. Duración de la alarma: 20 s, dos pitidos breves por segundo. Un pitido cada hora.
5. El sonido de TIMER tiene prioridad sobre el sonido de ALARM.

CARACTERÍSTICAS Y ESPECIFICACIONES

1. Modo de Tiempo: Horas, Minutos, Segundos, Meses, Fechas y Día de la semana.
2. Función:
 - * Función de temporizador (100 horas), 50 vueltas/parciales, vuelta media.
 - * Medidor de cuenta regresiva / Señal de silbato.
 - * 8 alarmas (4 alarmas diaria y 4 alarmas de fecha).
 - * Formato de 12/24 horas.
 - * Segunda zona horaria.
 - * Función de ACTIVACIÓN/DESACTIVACIÓN del sonido de los botones
 - * Mañana / Tarde, Luz Electroluminiscente.
3. Precisión a temperaturas normales (25°C): ±30 segundos por mes.
4. Rango de temperatura de operación normal: 10°C - 40°C



En aplicación de la normativa sobre los desechos de equipos eléctricos y electrónicos, los productos de relojería de cuarzo que se encuentran al final de su vida útil deben ser sometidos a una recogida selectiva en vistas a su posterior tratamiento. También puede depositar nuestros productos de relojería de cuarzo en uno de nuestros puntos de venta autorizados, así como en cualquier punto de recogida habilitado. La recogida selectiva, el tratamiento, la valoración y el reciclaje contribuyen a la salvaguarda de nuestro medio ambiente y a la protección de nuestra salud.

REGULAR DISPLAY AND BUTTON OPERATION

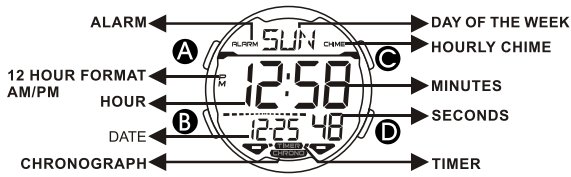

BUTTON OPERATION	
A SET/RECALL	C ADVANCE/START/SPLIT/LAP
B MODE	D RECEDE/STOP/ADJUST/LIGHT

CARE OF YOUR WATCH

1. This watch contains precise electronic components. Never attempt to open the case or remove the back cover.
2. Do not operate buttons while underwater, or while swimming or diving.
3. Should water or condensation appear in the watch, immediately have the watch checked. Water can corrode electronic parts inside the case.
4. Avoid severe impact: The watch is designed to withstand impact under normal use. Do not subject it to severe impacts or rough usage, and do not drop it onto hard surfaces.
5. Avoid exposing the watch to temperature extremes.
6. Clean the watch with a soft cloth and clean water only. Avoid using chemicals, especially soap.
7. Keep your watch away from strong electric fields and static electricity.

HOW TO CHANGE THE DISPLAY MODE

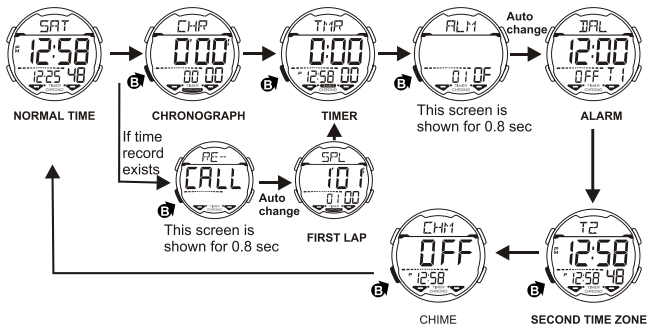

HOW TO DISPLAY CALENDAR

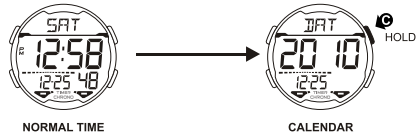

HOW TO SET NORMAL TIME

HOW TO SET NORMAL TIME

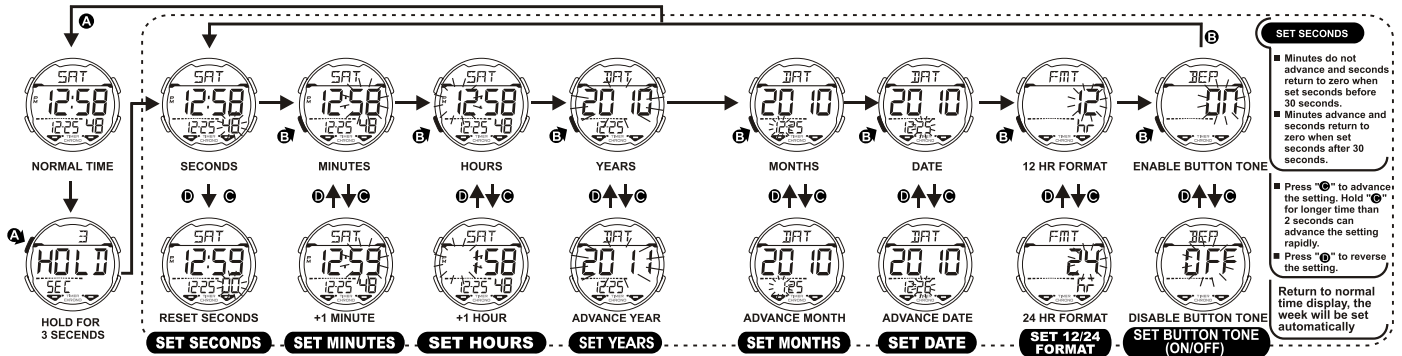

HOW TO USE THE CHRONOGRAPH

HOW TO CHANGE THE LAP/SPLIT MODE

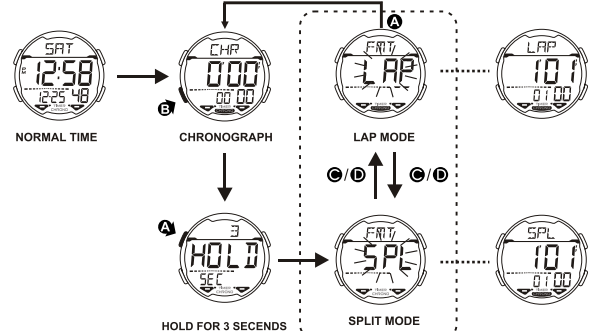
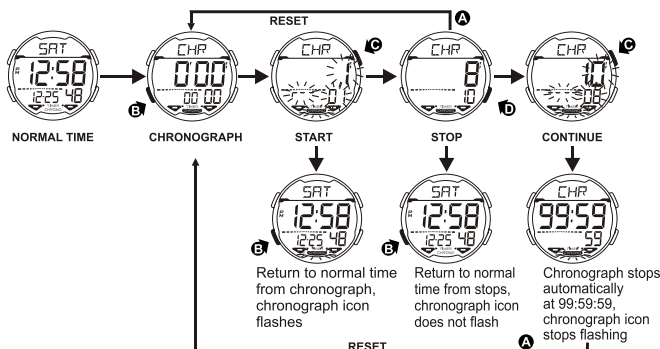

HOW TO SET THE SPLIT OR LAP OPERATION

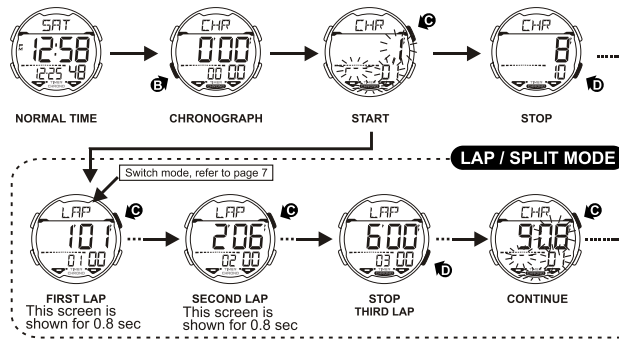

HOW TO SET THE SPLIT OR LAP OPERATION

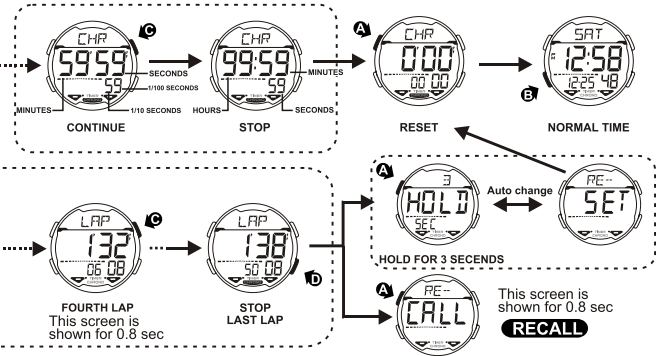

HOW TO USE THE RECALL

HOW TO USE THE RECALL

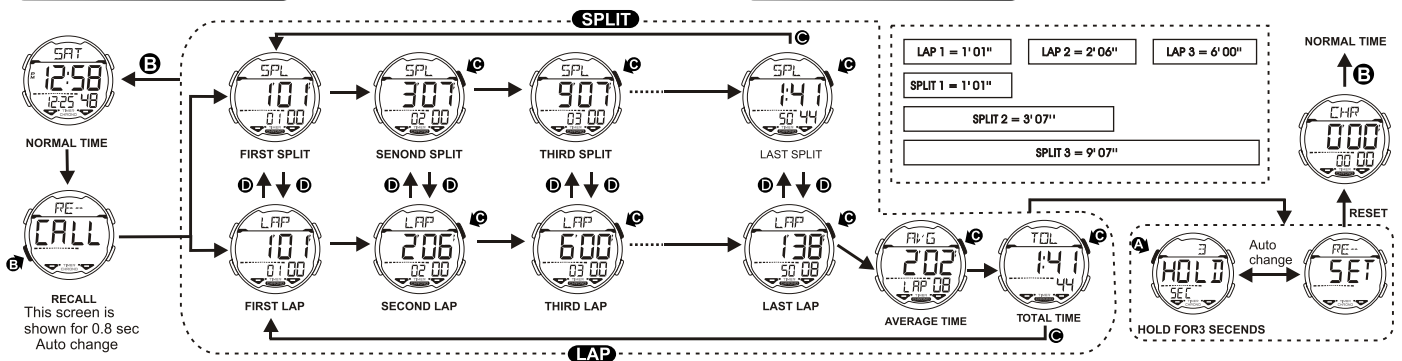

HOW TO USE TIMER

HOW TO USE TIMER

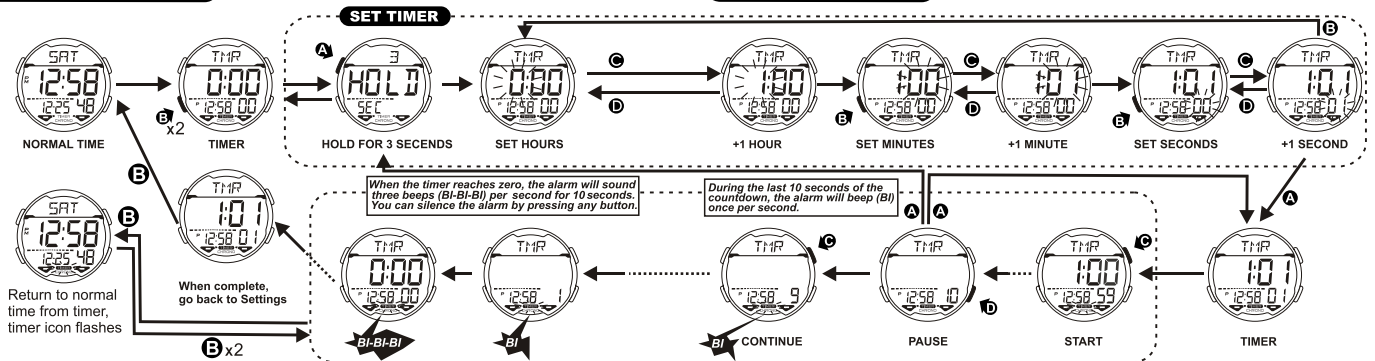

HOW TO SET DAILY ALARM TIME

HOW TO SET DAILY ALARM TIME

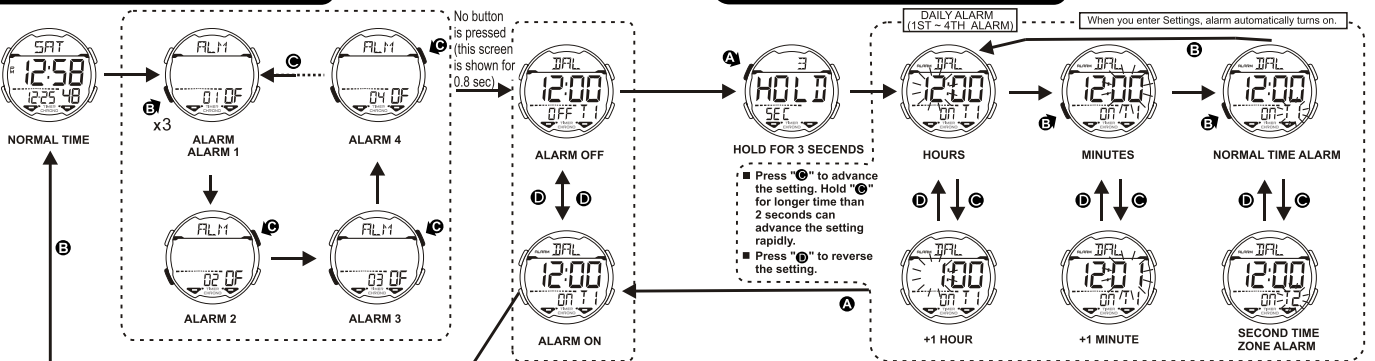

HOW TO SET DATE ALARM TIME

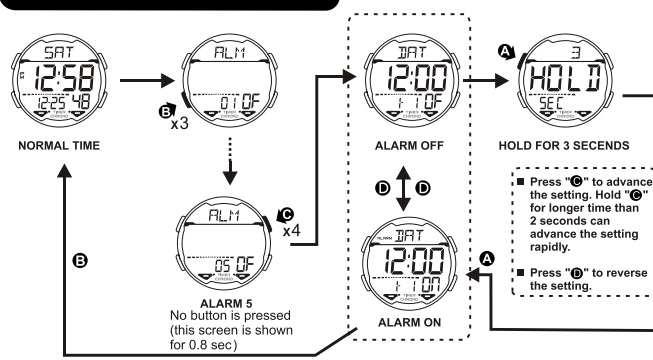

HOW TO SET DATE ALARM TIME

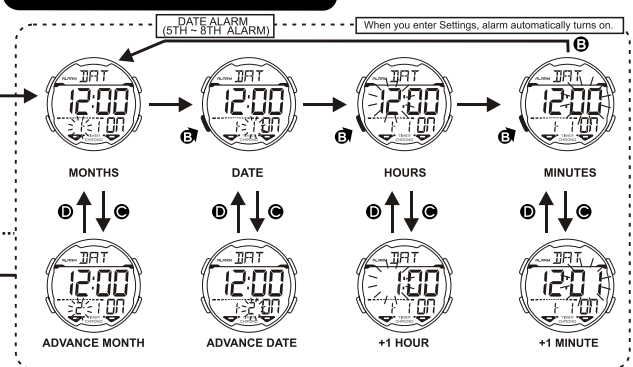

HOW TO SET SECOND TIME ZONE

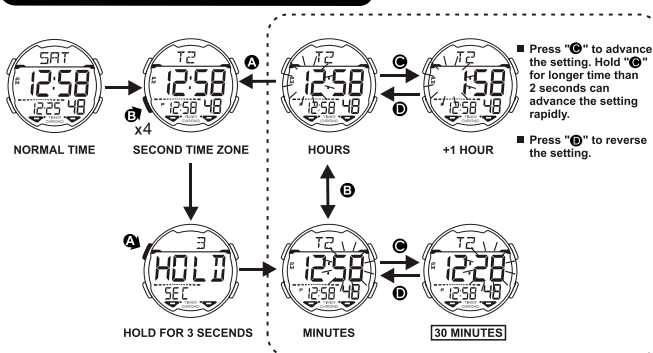

HOW TO SETUP HOURLY CHIME ON/OFF

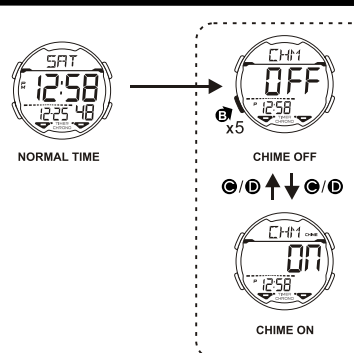

HOW TO USE EL LIGHT

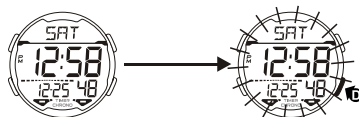

NOTE:

1. This watch features an electro-luminescent (EL) backlight, which tends to lose illuminating power after very long use.
2. The illumination provided by backlight may hard to see under direct sunlight.

SOUND

1. Button tone: Turn ON or OFF, see "How to set function display."
2. Beeps with each press of a button except for the LIGHT button.
3. The button will only beep once when pressed and held
4. Alarm duration: 20 sec, two short beeps per second, beep once every hour.
5. The TIMER sound will take priority over the ALARM sound

FEATURES AND SPECIFICATIONS

1. Standard display mode: Hour, Minutes, Seconds, Day of the week, Month, Date.
2. Function:
 - * 100-hour chronograph with memory for 50 laps / splits, and average lap.
 - * 24-hour countdown timer.
 - * 8 alarm (4 daily / 4 date) function with buzzer signal output.
 - * Second time zone.
 - * Hourly chime.
 - * Perpetual calendar.
 - * 12/24 hour format switch option.
 - * AM / PM & Electro-Luminescent light.
 - * Button tone ON/OFF function
3. Accuracy at normal temperature (25°C): ± 30 seconds a month.
4. Normal operating temperature range: 10°C ~ 40°C.



By virtue of the regulations pursuant to the handling of waste products deriving from electronic and electrical equipment, end of lifecycle watch making products must be selectively collected for processing. You may therefore dispose of your quartz watch making products at any of our retail outlets or any other authorized collection point. The selective collection, processing, rating and recycling of these products helps contribute to safeguarding the environment and protecting our health.

AFFICHAGE NORMALE ET BOUTON D'UTILISATION

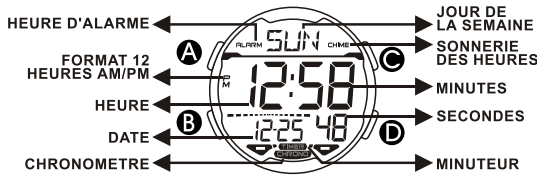

BOUTONS D'UTILISATION

A RÉGLAGE / RAPPELER	C AVANCER / MARCHÉ / CHEVAUCHEMENT/PARTAGE
B MODE	D RETOUR / ARRÊTÉR / ADJUSTMENT/LUMIÈRE

ENTRETIEN DE VOTRE MONTRE

1. Cette montre contient des composants électroniques de précision. Ne jamais tenter d'ouvrir le boîtier ou d'enlever le couvercle arrière.
2. Ne pas pousser les boutons sous l'eau ou lorsque vous nager ou faites de la plongée.
3. Si de l'eau ou de la condensation apparaît à l'intérieur de la montre, faites la vérifier immédiatement. L'eau peut corroder les parties électroniques à l'intérieur de boîtier.
4. Éviter les chocs violents. Cette montre est conçue pour résister à des chocs occasionnés par un usage normal, il n'est pas recommandé de lui infliger des chocs sévères dus à un usage rude ou de la laisser tomber sur une surface dure.
5. Éviter d'exposer cette montre à des températures extrêmes.
6. Nettoyer la montre avec un chiffon doux et de l'eau propre uniquement. Éviter d'utiliser des produits chimiques, en particulier le savon.
7. Tenir la montre éloignée des fortes conditions de champ électrique et d'électricité statique.

COMMENT CHANGER LE MODE D'AFFICHAGE

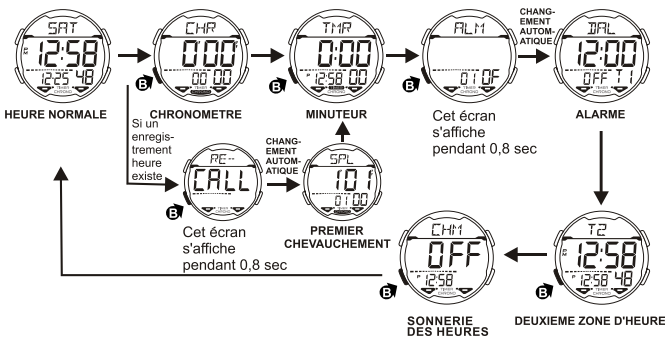

COMMENT AFFICHER LE MOIS, LA DATE

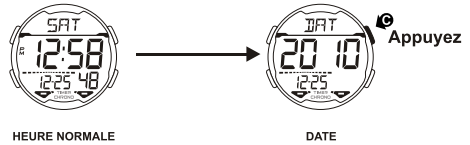

COMMENT RÉGLER L'HEURE NORMALE

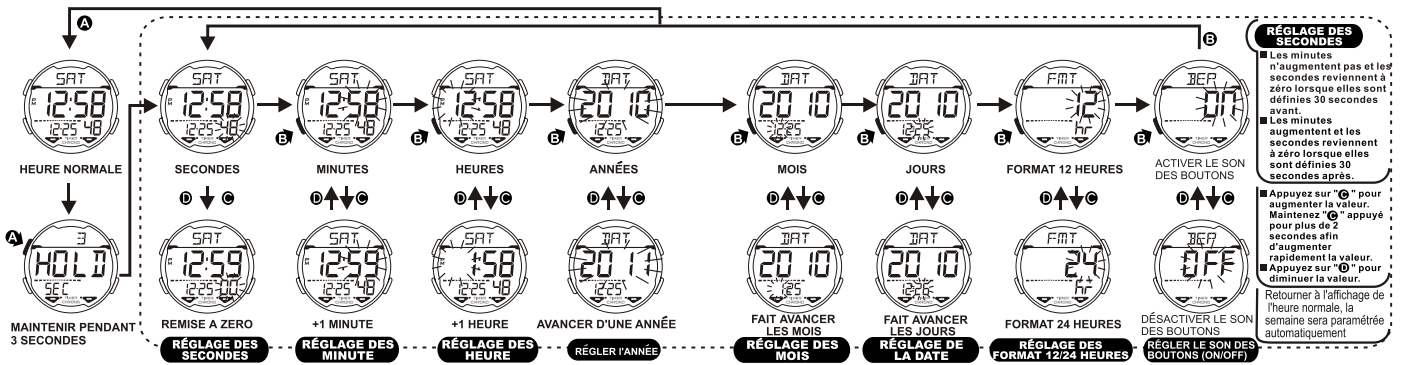

COMMENT RÉGLER L'HEURE NORMALE

COMMENT UTILISER LE CHRONOMETRE

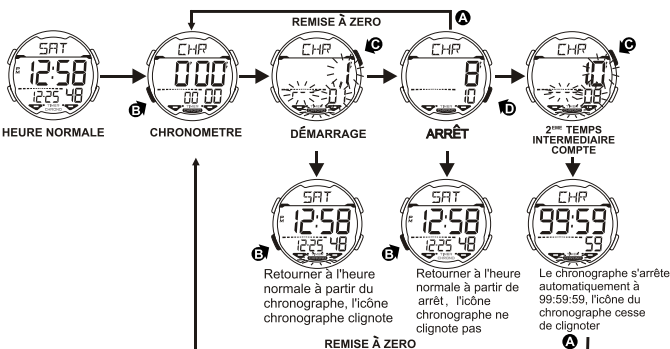

COMMENT CHANGER LE MODE CHEVAUCHEMENT/PARTAGE

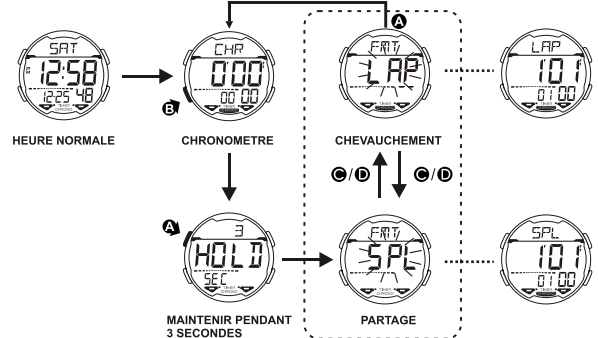

COMMENT REGLER L'UTILISATION DES COUPURES OU DES TOURS

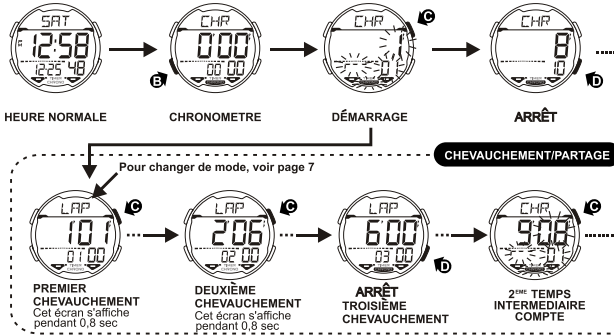

COMMENT REGLER L'UTILISATION DES COUPURES OU DES TOURS

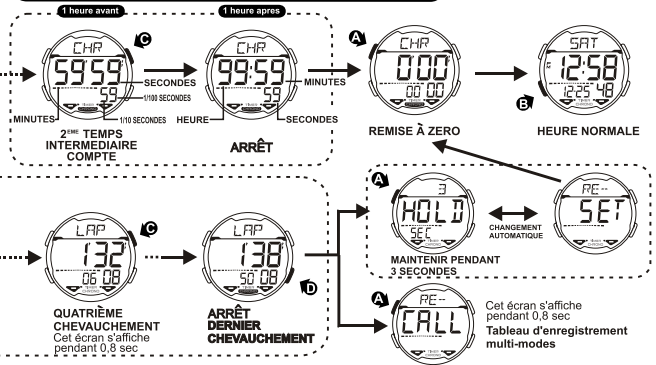

COMMENT UTILISER LA FONCTION RAPPELER

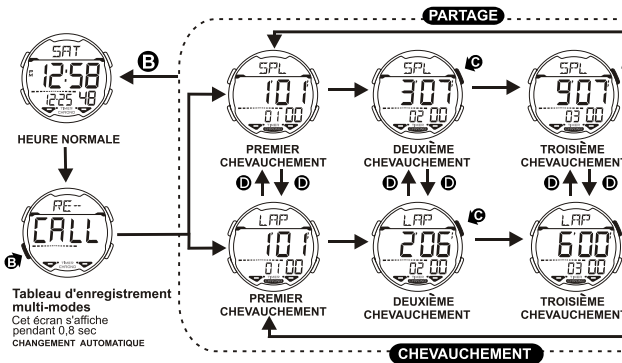

COMMENT UTILISER LA FONCTION RAPPELER

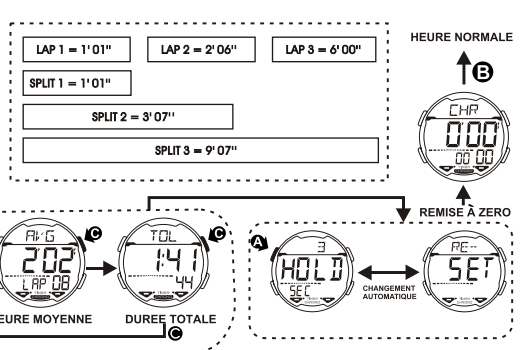

POUR UTILISER LE MINUTEUR DU COMPTE A REBOURS

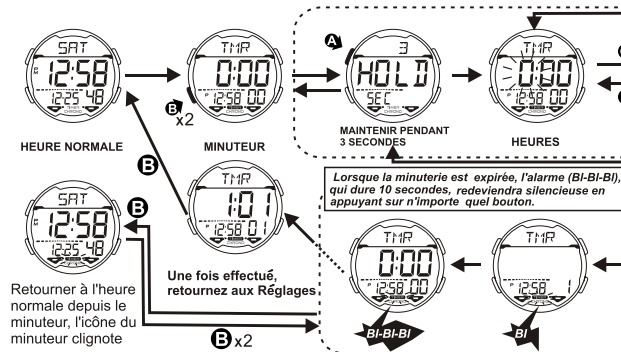

POUR UTILISER LE MINUTEUR DU COMPTE A REBOURS

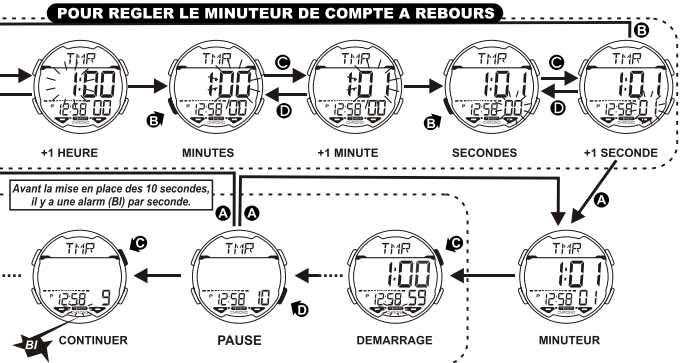

COMMENT RÉGLER L'HEURE DE L'ALARME QUOTIDIENNE

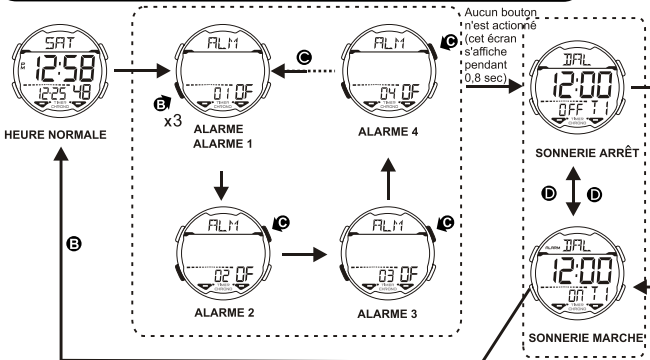

COMMENT RÉGLER L'HEURE DE L'ALARME QUOTIDIENNE

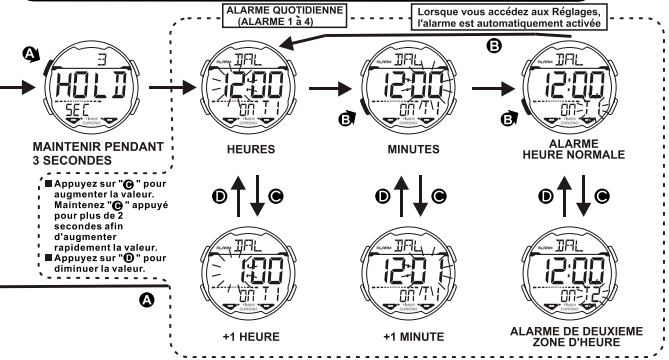

COMMENT RÉGLER L'HEURE DE L'ALARME DATE

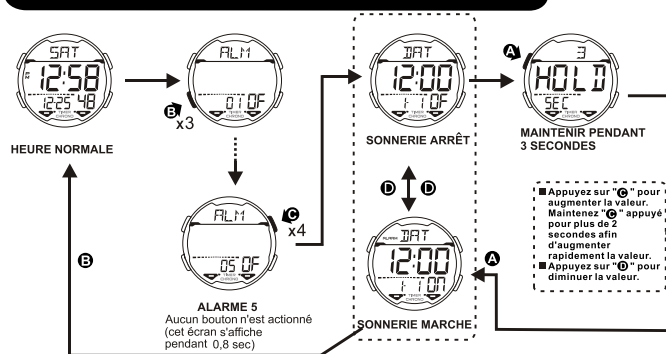

COMMENT RÉGLER L'HEURE DE L'ALARME DATE

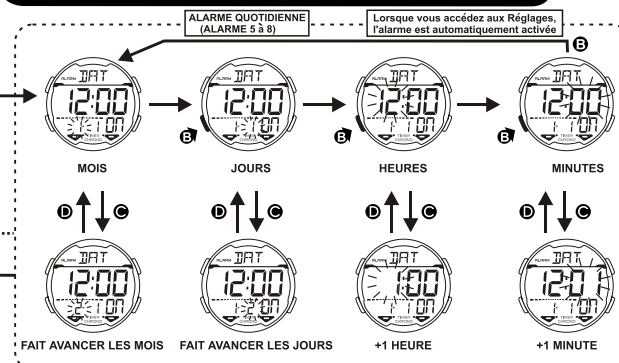

COMMENT RÉGLER L'HEURE D'UNE DEUXIEME ZONE

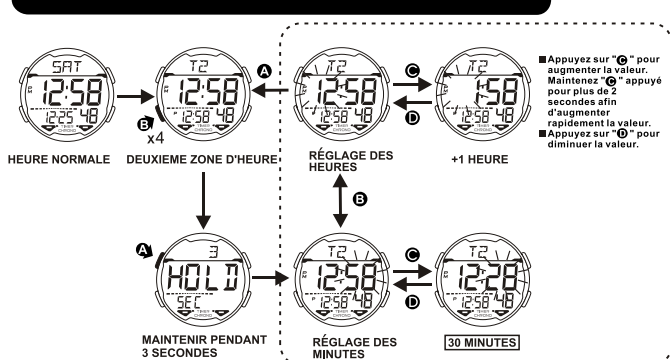

COMMENT ACTIVER/DÉSACTIVER LE CARILLON DES HEURES

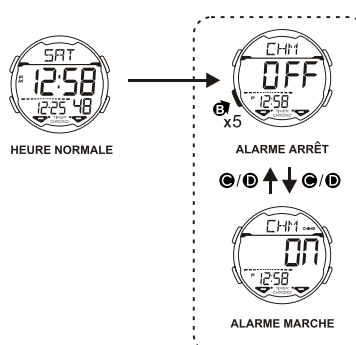

COMMENT ALLUMER LA LUMIERE ELECTRO-LUMINESCENTE

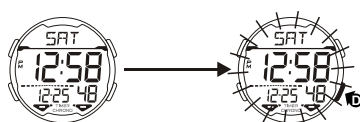

NOTE:

1. La lumière de fond de cette montre utilise une lumière électro-luminescente, cette montre a tendance à perdre de sa puissance de luminosité après un très long usage.
2. La luminosité de la lumière de fond peut être difficile à distinguer sous les rayons directs du soleil.

SON

1. Son des boutons : sur ON ou OFF, voir "Comment régler l'affichage des fonctions".
2. Bip à chaque pression d'un bouton, à l'exception du bouton LIGHT
3. Un seul bip va retentir si vous restez appuyé sur un bouton.
4. Durée de l'alarme : 20 sec, deux bips courts par seconde
Un bip chaque heure
5. Le son du TIMER a priorité sur le son de ALARM

CARACTÉRISTIQUES ET SPÉCIFICATIONS

1. Mode d'affichage standard: Heures, Minutes, Mois, Date, Jour de la semaine.
2. Fonctions:
 - * Fonction de la minuterie (100 heures), 50 chevauchements/partages, chevauchement moyen.
 - * Minuteur, Sonnerie des heures.
 - * 8 alarmes (4 alarmes quotidiennes, 4 alarmes avec date).
 - * Sélecteur de format 12/24 heures.
 - * Deuxième zone d'heure.
 - * Fonction ON/OFF du son des boutons
 - * Matin / Après-midi, lumière électroluminescente.
3. Précision à une température normale (25°C) ±30 seconds par mois.
4. Température limites pour un usage normal: 10°C-40°C.



En application de la réglementation sur les déchets des équipements électriques et électroniques, les produits horlogers à quartz en fin de vie font l'objet d'une collecte sélective en vue de leur traitement. Vous pouvez ainsi déposer nos produits horlogers à quartz dans l'un de nos points de vente agréés, ainsi que dans tout point de collecte habilité. La collecte sélective, le traitement, la valorisation et le recyclage contribuent à la sauvegarde de notre environnement et à la protection de notre santé.

GEWÖHNLICHE ANZEIGE UND KNOPFFUNKTIONEN

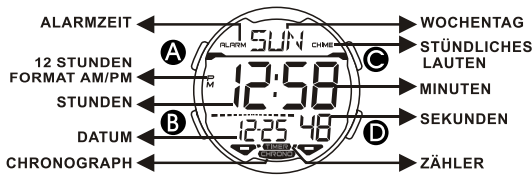

KNOPFGEBRAUCH

A SET / WIEDERAUFBRUF	C ERWEITERT / START / RUNDE / ZWISCHENZEIT
B MODUS	D ZURÜCK / EINSTELLEN DER / STOP / LICHT

BEHANDLUNG IHRER UHR

1. Diese Uhr verfügt über präzise elektronische Komponenten. Versuchen Sie niemals, das Gehäuse zu öffnen oder den Deckel der Rückseite zu entfernen.
2. Betätigen Sie die Knöpfe nicht unter Wasser während dem Schwimmen oder Tauchen.
3. Sollte Wasser oder Kondensierung in der Uhr auftauchen, lassen Sie sie bitte sofort überprüfen, Feuchtigkeit kann Korrosion der elektrischen Teile verursachen.
4. Verhindern Sie harte Stöße. Die Uhr ist geeignet, nur Stößen unter normalen Bedingungen standzuhalten. Es wird nicht empfohlen, sie übermäßig starken Stößen oder grober Behandlung auszusetzen oder sie auf harte Oberflächen fallen zu lassen.
5. Vermeiden Sie es, die Uhr extremen Temperaturen auszusetzen.
6. Reinigen Sie die Uhr nur mit einem sanften Tuch und sauberem Wasser. Vermeiden Sie Chemikalien, insbesondere Seife.
7. Halten Sie Ihre Uhr fern von Umgebungen mit starkem Elektrofeld und statischer Elektrizität.

DAS WECHSELN DES ANZEIGENMODUS

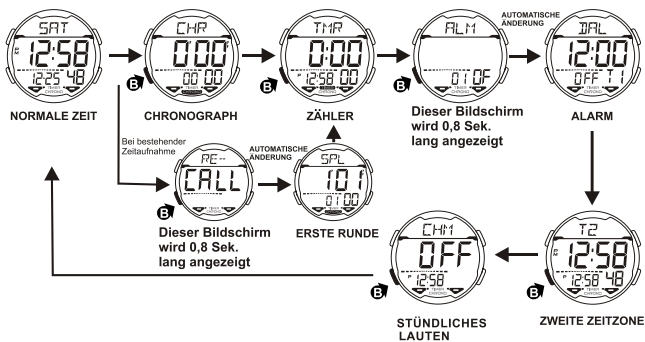

MONAT UND DATUM ANZEIGEN

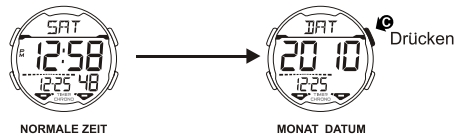

DAS EINSTELLEN DER NORMALE ZEIT

DAS EINSTELLEN DER NORMALE ZEIT

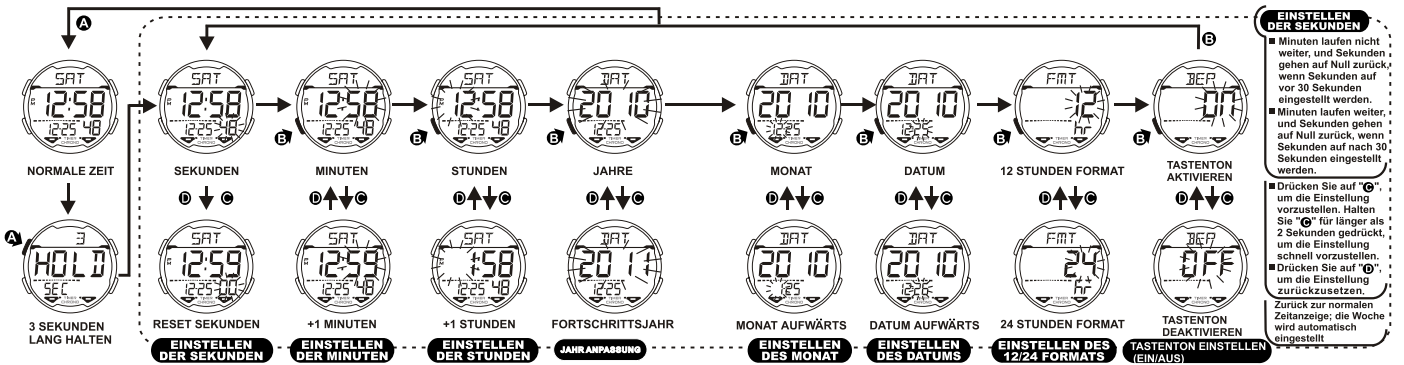

DIE BENUTZUNG DES CHRONOGRAPH

SO WECHSELN SIE DEN RUNDEN- / ZWISCHENZEITMODUS

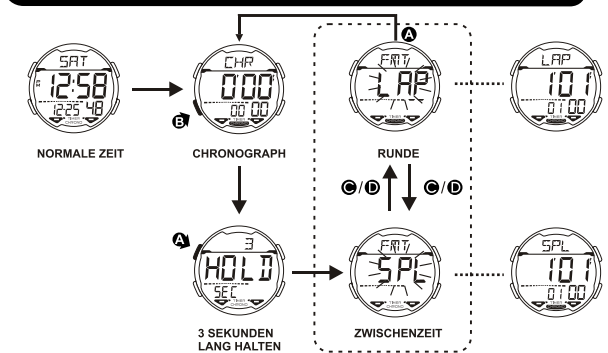
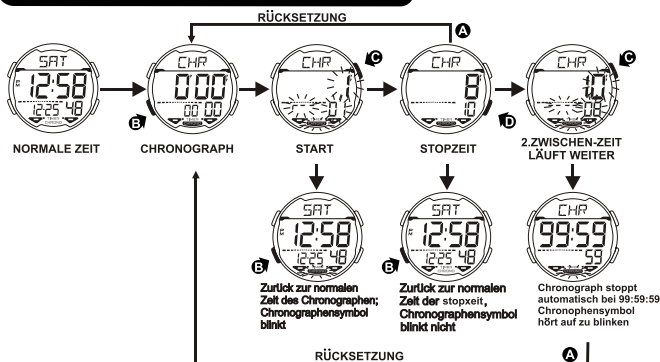

DAS EINSTELLEN DER SPLIT ODER LAP-FUNKTIONSGEBRAUCHS

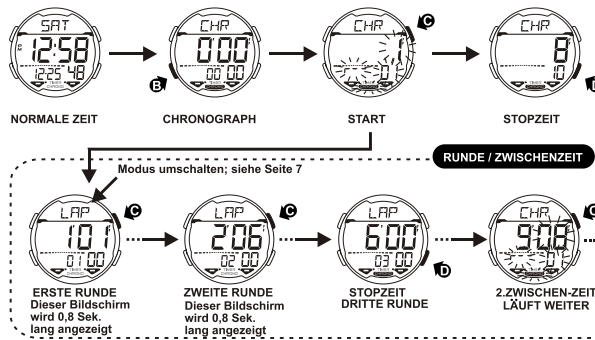

DAS EINSTELLEN DER SPLIT ODER LAP-FUNKTIONSGEBRAUCHS

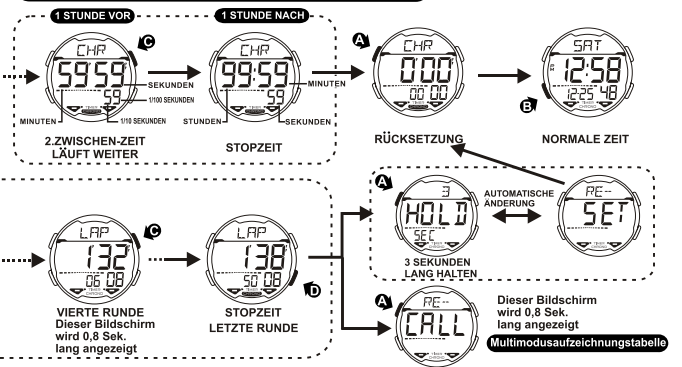

SO NUTZEN SIE DIE FUNKTION WIEDERAUF RUF

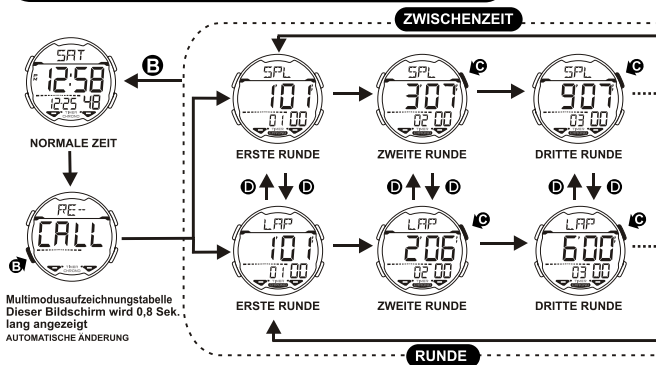

SO NUTZEN SIE DIE FUNKTION WIEDERAUF RUF

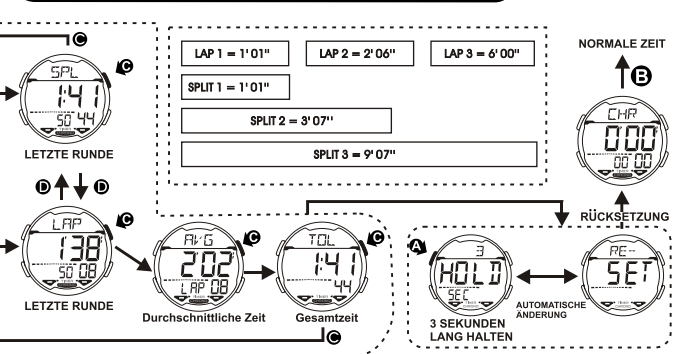

DAS EINSTELLEN DES COUNTDOWN ZÄHLERS

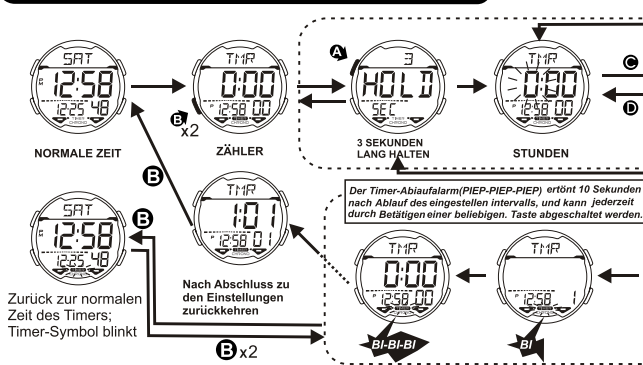

DAS EINSTELLEN DES COUNTDOWN ZÄHLERS

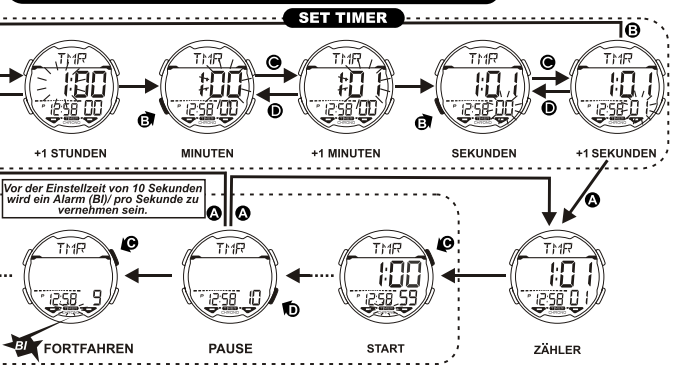

SO STELLEN SIE DIE TÄGLICHE ALARMZEIT EIN

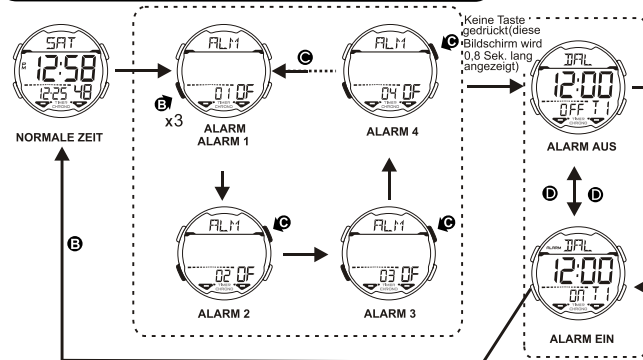

SO STELLEN SIE DIE TÄGLICHE ALARMZEIT EIN

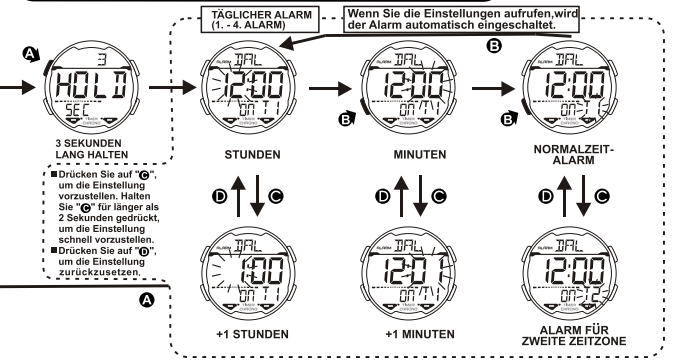

SO STELLEN SIE DIE TERMINALARMSZEIT EIN

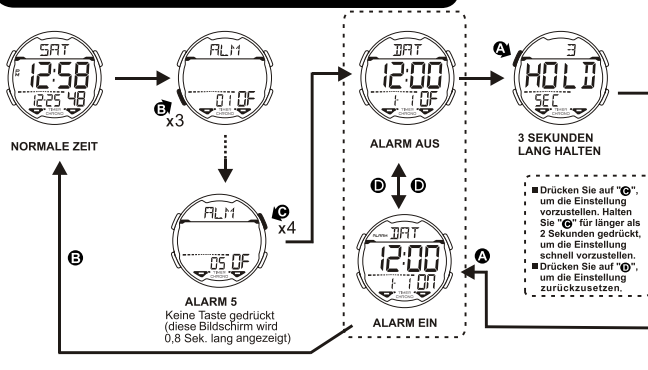

SO STELLEN SIE DIE TERMINALARMSZEIT EIN

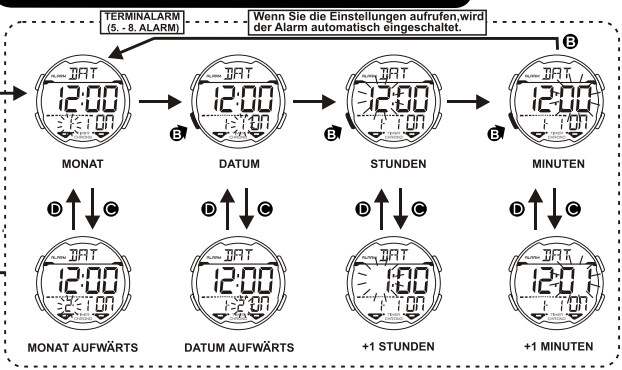

ZEIT FÜR ZWEITE ZEITZONE PROGRAMMIEREN

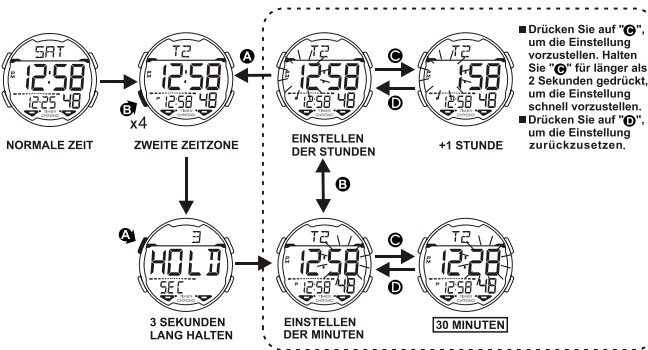

SO STELLEN SIE DEN STUNDLICHEN SIGNALTON EIN / AUS

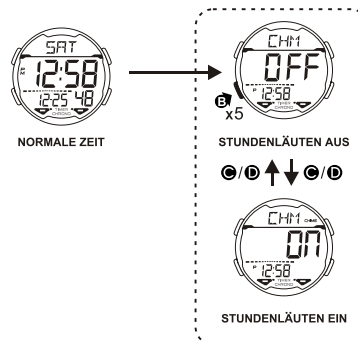

DIE EL BELEUCHTUNG

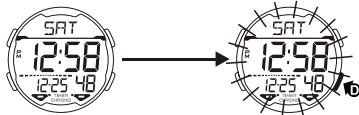

NOTE:

1. La lumière de fond de cette montre utilise une lumière électro-luminescente, cette montre a tendance à perdre de sa puissance de luminosité après un très long usage.
2. La luminosité de la lumière de fond peut être difficile à distinguer sous les rayons directs du soleil.

Ton

1. Tastenton: Ein-/ausschalten; siehe "So stellen Sie die Funktionsanzeige ein".
2. Gibt beim Drücken einer Taste mit Ausnahme der Licht-Taste einen Ton aus.
3. Bei Gedrückhalten einer Taste gibt das Gerät nur einen Ton aus.
4. Alarmdauer: 20 Sek., zwei kurze Signaltöne pro Sekunde
Ein Signalton pro Stunde
5. Der Timer-Ton hat eine höhere Priorität als der Alarm-Ton.

FUNKTIONEN UND TECHNISCHE DATEN

1. Normalzeit-Anzeige-Modus: Stunden, Minuten, Sekunden, Monat, Wochentag, Datum.
2. Funktionen:
 - * Timerfunktion (100 Stunden), 50 Runden / Zwischenzeiten, Durchschnittliche Runde
 - * Zähler/Stündliches Lauten
 - * 8 Alarme (4 tägliche Alarme, 4 Datumsalarme)
 - * 12/24 Stunden Anzeigeformate wählbar.
 - * Ein-/Ausschalten des Tastentons
 - * Morgen / Nachmittag und Elektro-Lumineszenz-Anzeigebeleuchtung.
 - * Zweite zeitzone.
3. Genauigkeit unter normalen Temperaturen: ±30 s/Monat.
4. Normalgräuchlicher Temperaturbereich: 10-40 Grad Celsius.



Gemäß den Bestimmungen über die Behandlung von Abfällen durch Elektronik- und Elektro-Altgeräte sind Quarzuhrenprodukte, deren Lebensdauer abgelaufen ist, selektiv zu sammeln, um sie dem Recycling zuzuführen. Sie können Ihre Quarzuhrenprodukte daher in einer unserer Verkaufsstellen oder an einer beliebigen Sammelstelle abgeben. Die selektive Sammlung, die Verarbeitung, die Bewertung und das Recycling dieser Produkte ist ein Beitrag zum Umweltschutz und zum Schutz unserer Gesundheit.

REGOLARE DISPLAY E FUNZIONAMENTO DEI PULSANTI

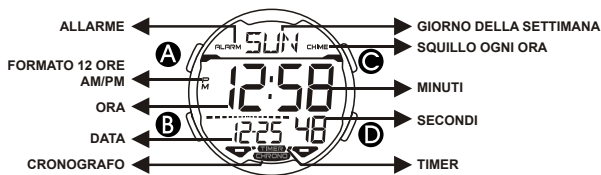

OPERAZIONE PULSANTE

- A** IMPOSTAZIONE/RICORDA
- B** MODALITÀ
- C** AVANZAMENTO / START / SPLIT / GIRO
- D** RECEDERE / STOP / REGOLARE / LUCE

PRENDITI CURA DEL TUO OROLOGIO

1. Questo orologio contiene componenti elettromeccanici di alta qualità. Non tentare mai di aprire il contenitore o di rimuovere il coperchio posteriore.
2. Non azionare i pulsanti mentre si è sott'acqua, o durante il nuoto o l'immersione.
3. Se nell'orologio dovesse apparire acqua o condensa, far controllare immediatamente l'orologio. L'acqua può danneggiare le parti elettroniche dell'orologio.
4. Evitare urti forti: L'orologio è progettato per resistere agli urti in condizioni d'uso normali. Non sottoporlo a forti impatti o ad un uso brusco, e non farlo cadere su superfici dure.
5. Evitare di esporre l'orologio a temperature estreme.
6. Pulire l'orologio con un panno morbido e pulirlo solo con acqua. Evitare l'uso di prodotti chimici, specialmente sapone.
7. Tenere l'orologio lontano da forti campi elettrici e da elettricità statica."

COME CAMBIARE LA MODALITÀ DI VISUALIZZAZIONE

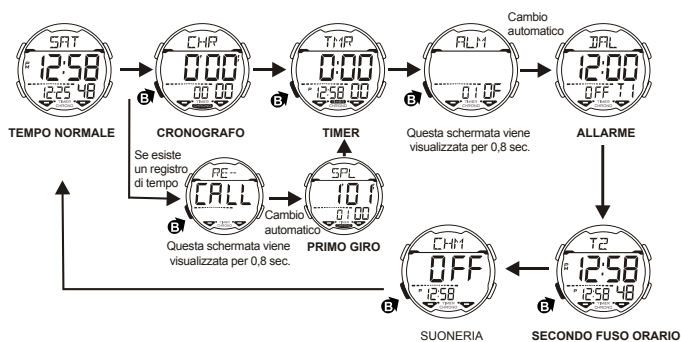

COME VISUALIZZARE IL CALENDARIO



COME IMPOSTARE IL TEMPO NORMALE

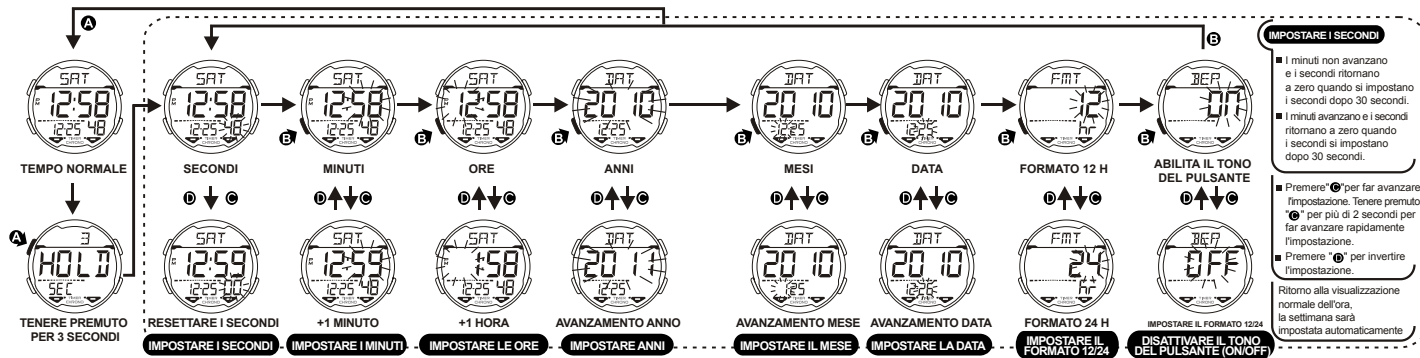

COME UTILIZZARE IL CRONOGRAFO

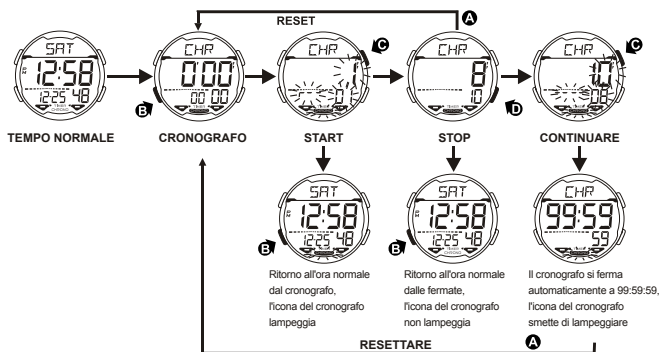

COME CAMBIARE LA MODALITÀ GIRO/SPLIT

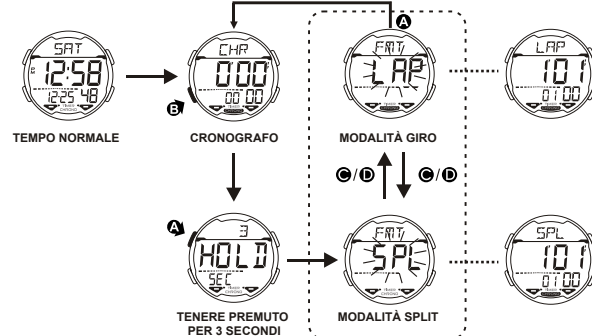

COME IMPOSTARE L'OPERAZIONE DI SPLIT O GIRO

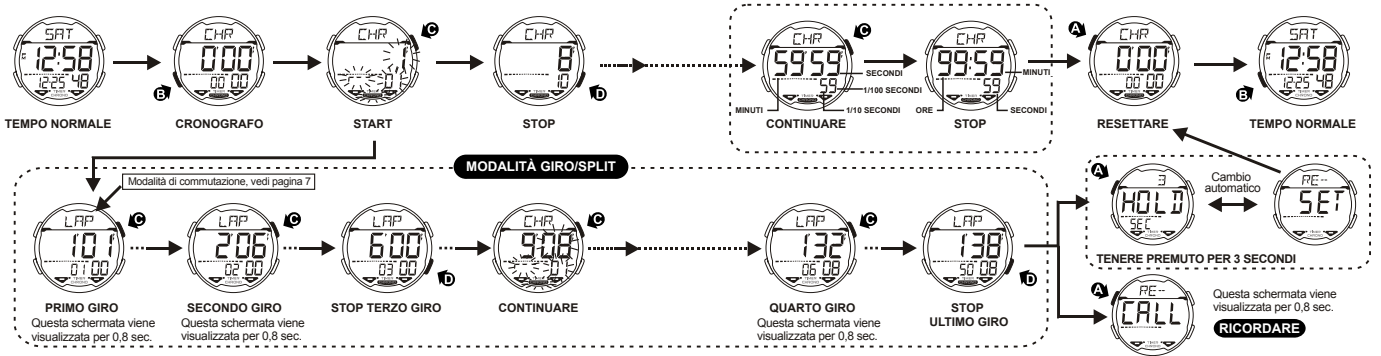

COME UTILIZZARE IL RICHIAMO

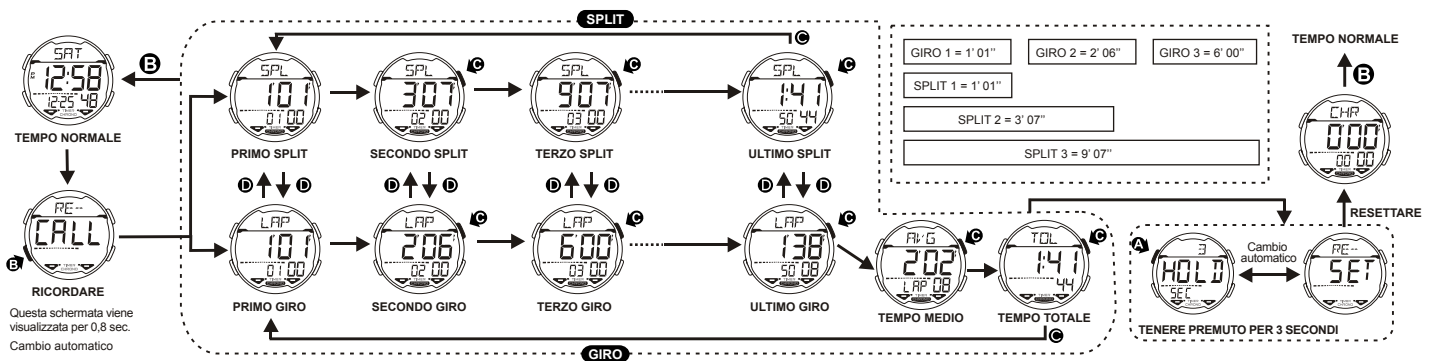

COME USARE IL TIMER

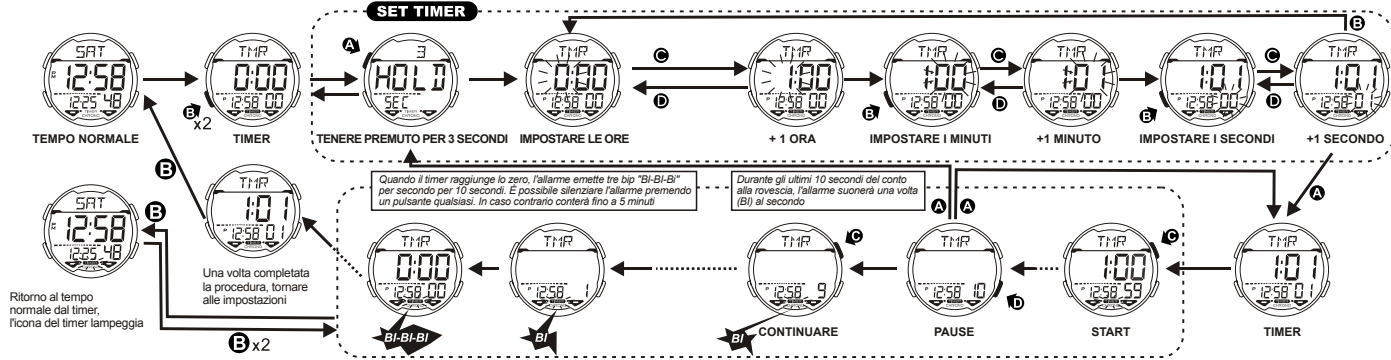

COME IMPOSTARE L'ORA DELL'ALLARME GIORNALIERO

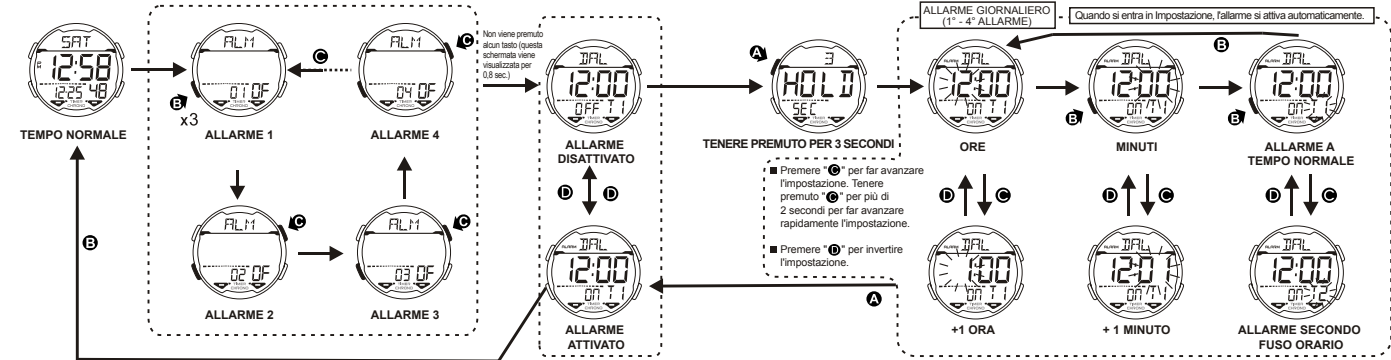

COME IMPOSTARE L'ORA DELL'ALLARME DATA

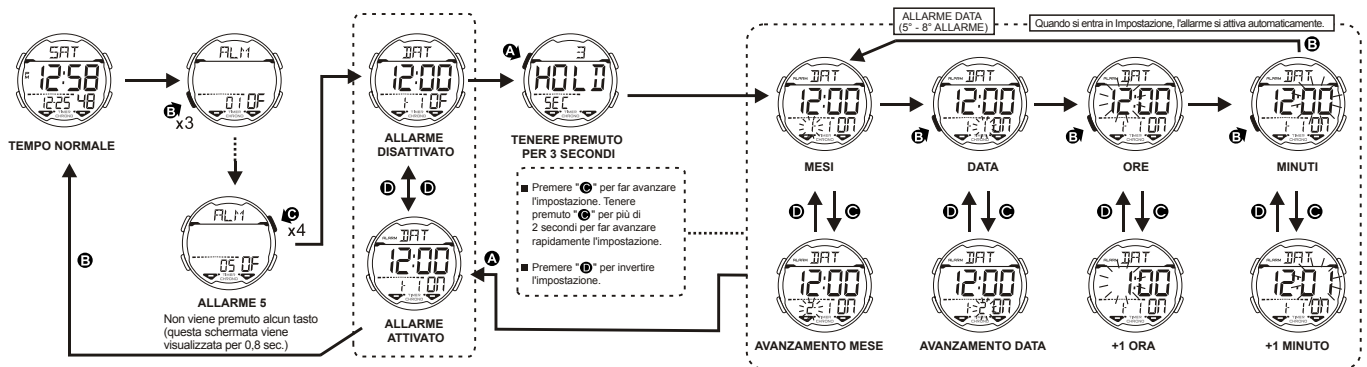

COME IMPOSTARE IL SECONDO FUSO ORARIO

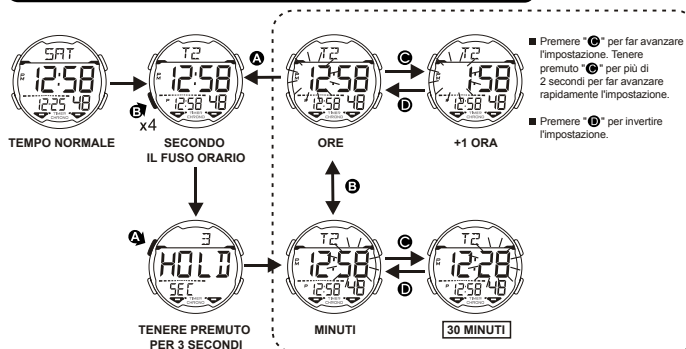

COME IMPOSTARE LA SUONERIA ORARIA ON/OFF

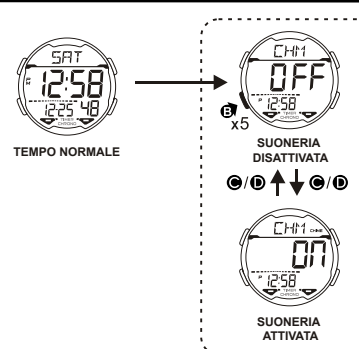

COME USARE LA LUCE

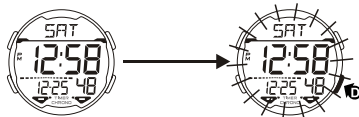

NOTA:

1. Questo orologio è dotato di una retroilluminazione elettroluminescente (EL), l'orologio tende a perdere potenza illuminante dopo un uso molto lungo
2. L'illuminazione fornita dalla retroilluminazione può essere difficile da vedere sotto la luce diretta del sole

SONORO

1. Tono del pulsante: ON o OFF, vedere "Come impostare la visualizzazione delle funzioni".
2. Suona ad ogni pressione del tasto, ad eccezione del tasto LUCE
3. Il pulsante emette un solo segnale acustico quando viene tenuto premuto
4. Durata dell'allarme: 20 sec, due brevi bip al secondo, bip una volta ogni ora
5. Il suono del TIMER avrà la priorità sul suono dell'ALLARME"

CARATTERISTICHE E SPECIFICAZIONI

1. "Modalità di visualizzazione standard: Ore, Minuti, Secondi, Giorno della settimana, Mesi, Data,."
2. Funzione:
 - *Cronografo da 100 ore con memoria per 50 giri/split e giro medio.
 - *Timer con conto alla rovescia di 24 ore
 - *8 funzione di allarme (4 giornalieri / 4 date) con uscita segnale acustico
 - *Secondo fuso orario
 - *Suoneria oraria.
 - *Calendario perpetuo.
 - *Opzione di commutazione del formato 12/24 ore.
 - *AM/PM e luce elettroluminescente.
 - *Tono a bottone funzione ON/OFF
3. Precisione a temperatura normale (25°C): ±30 secondi al mese.
4. Intervallo di temperatura di funzionamento normale: 10°C ~ 40°C."



Ai sensi dei regolamenti relativi alla manipolazione dei rifiuti provenienti da assemblaggi elettrici ed elettronici, i prodotti d'orologeria ormai inutilizzabili devono essere raccolti separatamente per consentirne il trattamento. In qualsiasi nostro punto vendita o punto di raccolta autorizzato troverà gli appositi contenitori per lo smaltimento dei componenti del Suo orologio al quarzo. La raccolta differenziata, il trattamento, la valorizzazione ed il riciclaggio di tali prodotti contribuiscono alla salvaguardia dell'ambiente ed alla produzione della nostra salute.

MOSTRADOR E FUNCIONAMENTO DOS BOTÕES

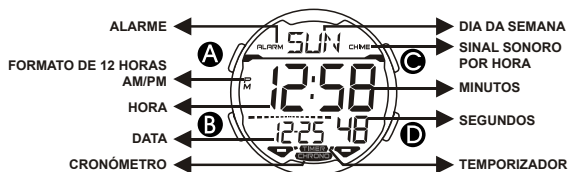

FUNCIONAMENTO DOS BOTÕES

- A** DEFINIR/LEMBRAR
- B** MODO
- C** AJUSTAR/INICIAR/PARAR/ SPLIT/VOLTA
- D** RETROCEDER/PARAR/ AJUSTAR/LUZ

PRENDITI CURA DEL TUO OROLOGIO

1. Questo orologio contiene componenti elettromeccanici di alta qualità. Non tentare mai di aprire il contenitore o di rimuovere il coperchio posteriore.
2. Non azionare i pulsanti mentre si è sott'acqua, o durante il nuoto o l'immersione.
3. Se nell'orologio dovesse apparire acqua o condensa, far controllare immediatamente l'orologio. L'acqua può danneggiare le parti elettroniche dell'orologio.
4. Evitare urti forti: L'orologio è progettato per resistere agli urti in condizioni d'uso normali. Non sottoporlo a forti impatti o ad un uso brusco, e non farlo cadere su superfici dure.
5. Evitare di esporre l'orologio a temperature estreme.
6. Pulire l'orologio con un panno morbido e pulirlo solo con acqua. Evitare l'uso di prodotti chimici, specialmente sapone.
7. Tenere l'orologio lontano da forti campi elettrici e da elettricità statica."

COMO ALTERAR O MODO DE APRESENTAÇÃO

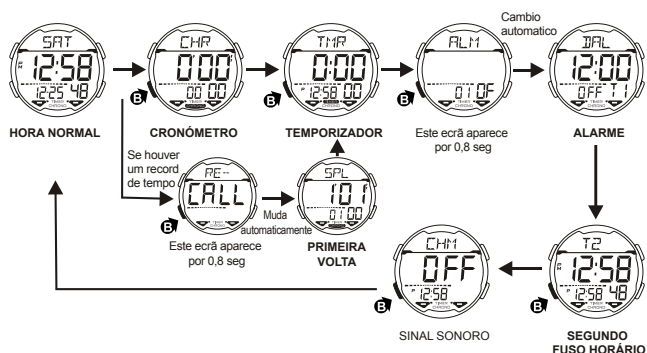

COMO EXIBIR O CALENDÁRIO



COMO DEFINIR AS HORAS

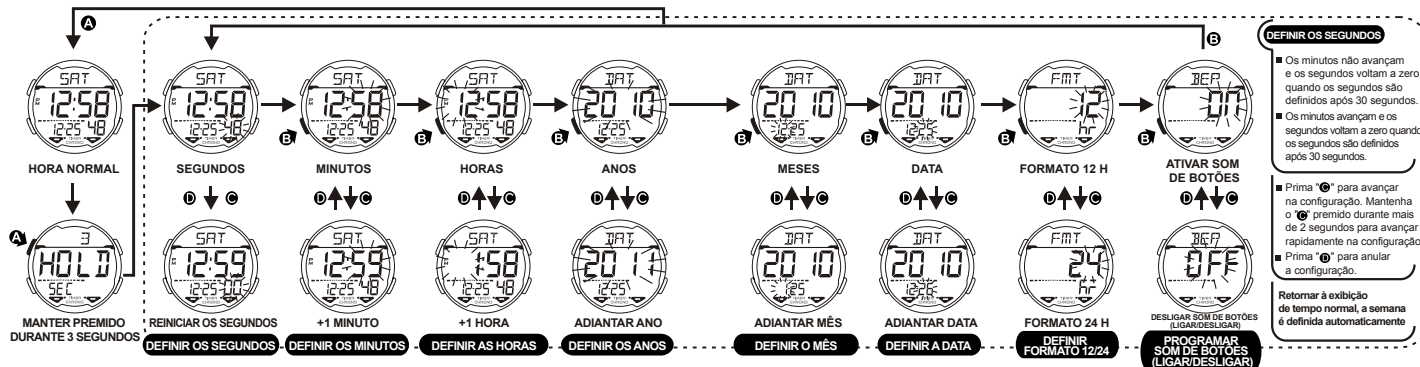

COMO UTILIZAR O CRONÓGRAFO

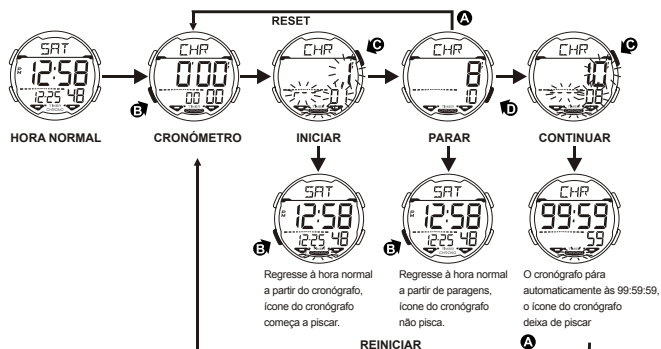

COMO MUDAR PARA O MODO VOLTA/SPLIT

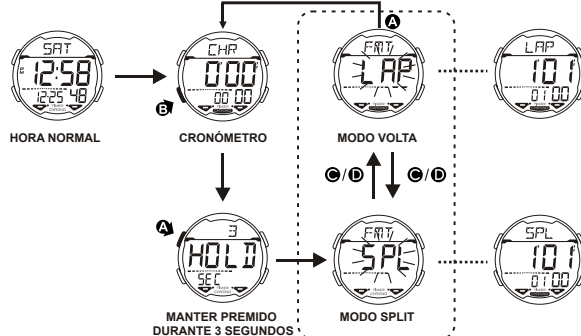

COMO ATIVAR A ATIVIDADE SPLIT OU VOLTA

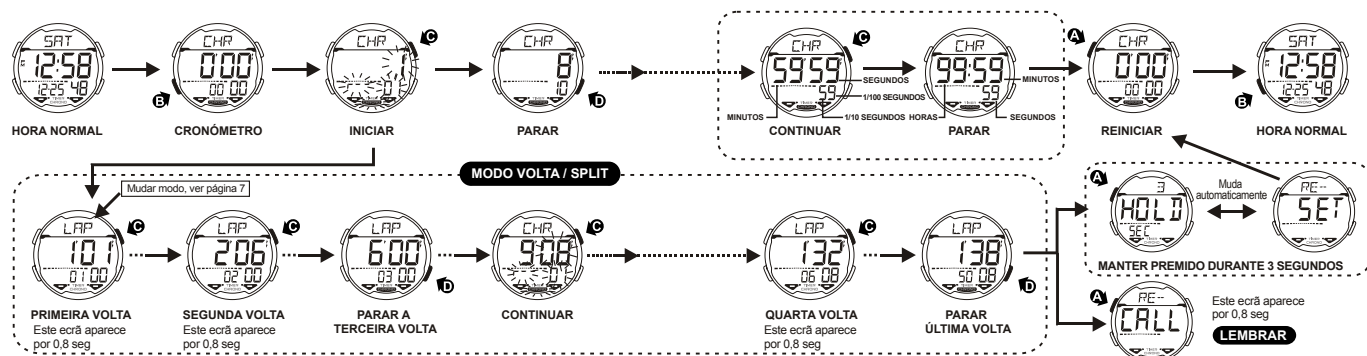

COMO UTILIZAR A FUNÇÃO LEMBRAR

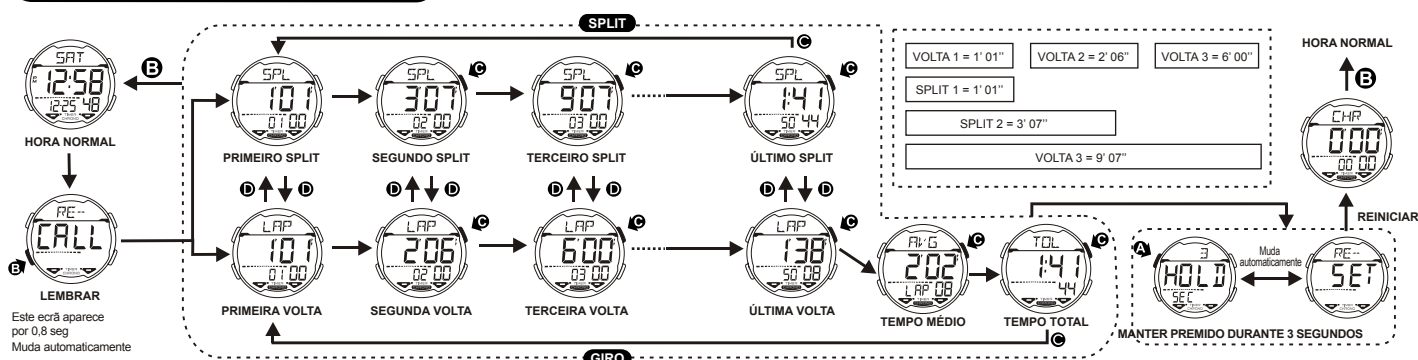

COMO UTILIZAR O TEMPORIZADOR

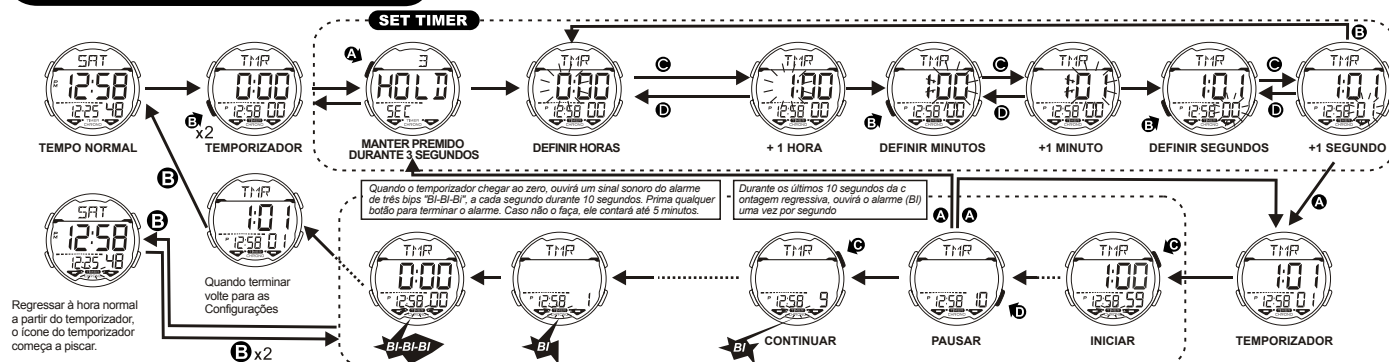

COMO PROGRAMAR UM ALARME DIÁRIO

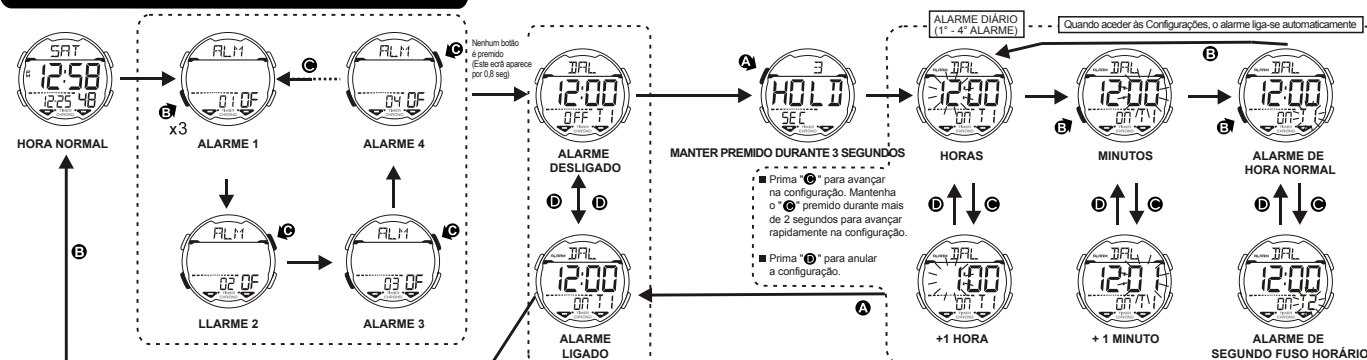

COMO PROGRAMAR UM ALARME DE DATA

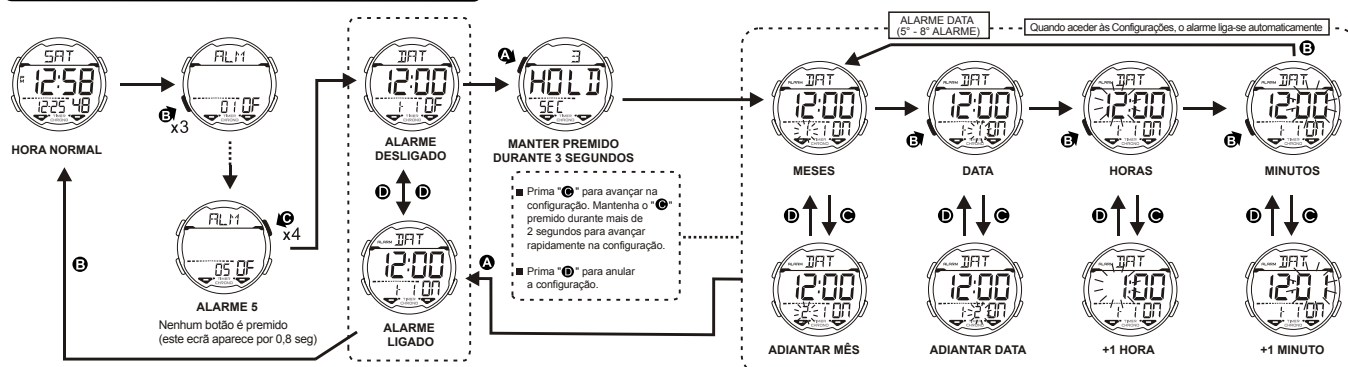

COMO IMPOSTARE IL SECONDO FUSO ORARIO

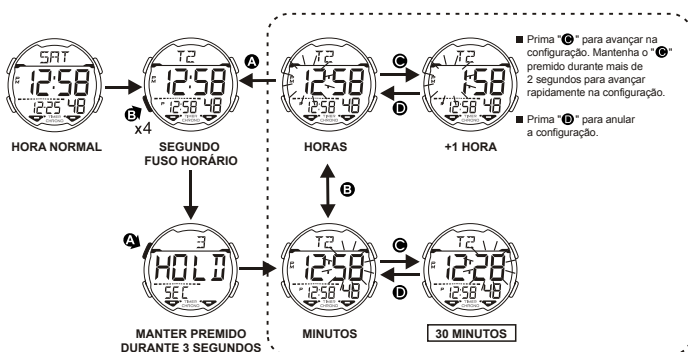

COMO PROGRAMAR O SINAL SONORO PARA LIGAR/DESLIGAR A CADA HORA

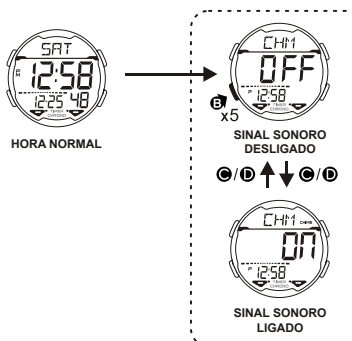

COMO UTILIZAR A LUZ

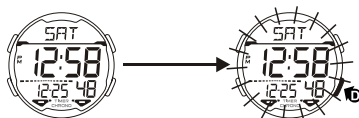

OBSERVAÇÃO:

1. Este relógio possui uma luz eletro-luminiscente (EL) de fundo, que tende a perder a sua potência após uma utilização muito longa
2. A iluminação fornecida pela luz de fundo pode ser difícil de ver quando vista sob a luz solar direta

SOM

1. Botão de som: LIGAR ou DESLIGAR, consulte "Como ativar a exibição de funções"
2. Emite um som com cada botão premido, exceto o botão LUZ
3. O botão só emite um único beep quando mantido premido
4. Duração do alarme: 20 seg, dois beeps curtos por segundo, um beep a cada hora
5. O som do TEMPORIZADOR prevalece ao som do ALARME

CARACTERÍSTICAS E ESPECIFICAÇÕES

1. Modo de indicação do tempo: Horas, Minutos, Segundos, Dia da semana, Meses, Data.
2. Função:
 - * Cronógrafo de 100 horas com memória para 50 voltas /splits, e volta média.
 - * Temporizador de contagem decrescente de 24 horas.
 - * 8 funções de alarme (4 diárias / 4 datas) com emissão de sinal sonoro.
 - * Segundo fuso horário.
 - * Sinal sonoro por hora.
 - * Calendário perpétuo.
 - * Opção de mudança de formato para 12/24 horas.
 - * AM/PM & Luz Eletroluminiscente.
 - * Função de LIGAR/DESLIGAR som dos botões.
3. Precisão a temperatura normal (25°C; ±30 segundos por mês).
4. Intervalo de temperatura de funcionamento: 10°C ~ 40°C.



Em cumprimento das regras sobre resíduos de equipamentos elétricos e eletrônicos, os produtos de relojoaria de quartzo que tenham atingido o final da sua vida útil devem ser recolhidos seletivamente para seu processamento posterior. Os nossos produtos de quartzo podem também ser depositados em um dos nossos pontos de venda autorizados bem como em qualquer local autorizado para esse fim. La colheita separada, o tratamento, a avaliação e a reciclagem contribuem para a proteção do nosso ambiente e da nossa saúde.