

Montageanleitung | Instructions de montage

Assembly Instructions | Instrucciones de montaje

SKU NUMBER: WF312933/WF312934

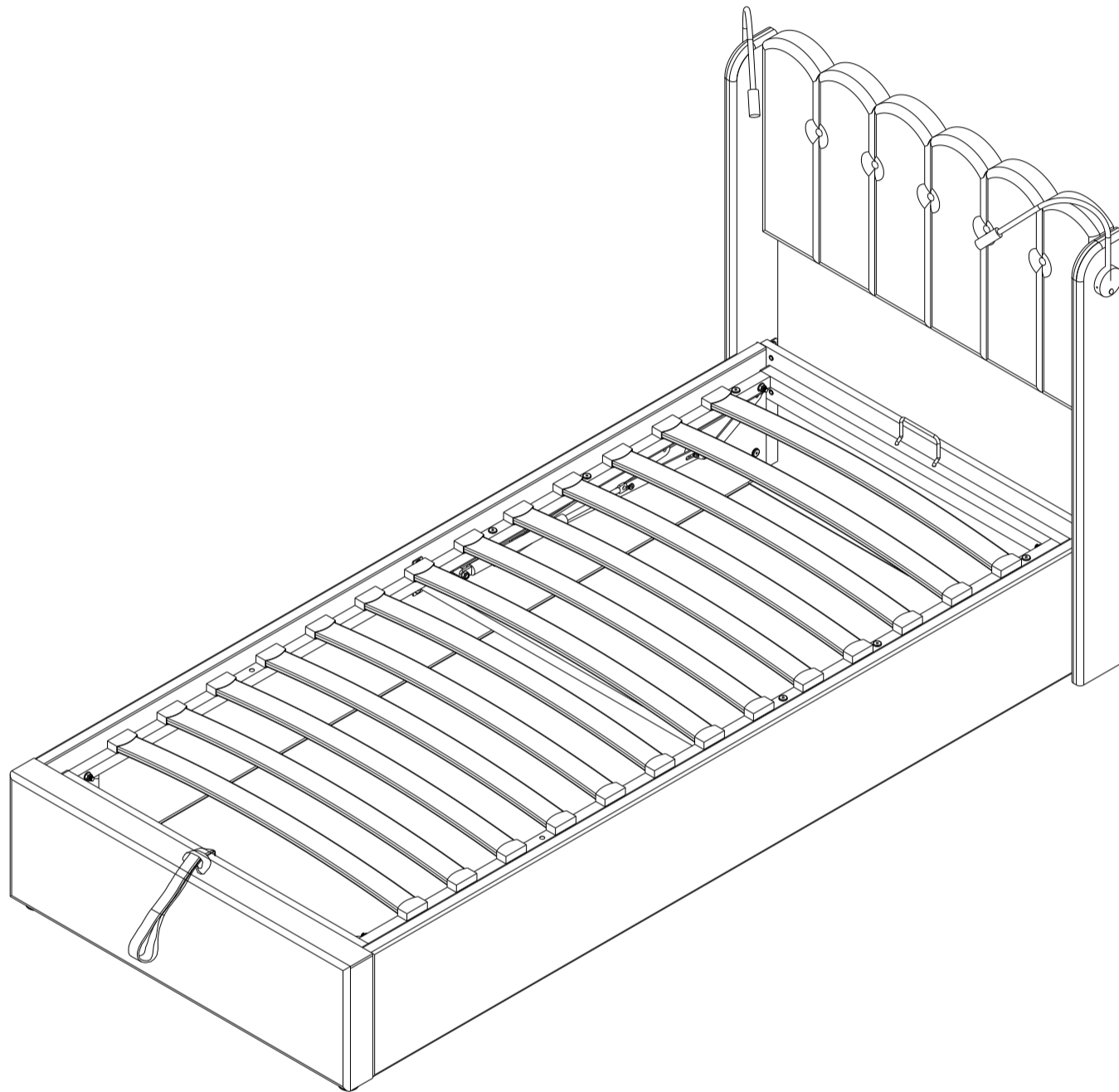

GB This set comes in 2 boxes. If you do not receive a full set of 2 boxes, please contact our customer service.

DE Dieses Set wird in 2 Schachteln geliefert. Wenn Sie nicht ein komplettes Set von 2 Boxen erhalten, kontaktieren Sie bitte unseren Kundenservice.

FR Ce set est livré en 2 boîtes. Si vous ne recevez pas un jeu complet de 2 boîtes, veuillez contacter notre service clientèle.

English

IMPORTANT ! KEEP FOR FUTURE REFERENCE : READ CAREFULLY

- To be assembled by an adult. Assembly must be checked by an adult before use
- WARNING ! Keep all screws, small parts and plastic bags out of the reach of children
- Properly identify all parts before assembling
- Never use your item if any of its parts are broken or missing
- Should any problems arise, please contact our After Sales Service
- Manufacturer's instructions shall be followed at all times
- Care: Clean with a soft, dry cloth. In case of larger stains, carefully rub with a slightly damp, non-abrasive sponge
- Do not jump on the bed

Français

IMPORTANT ! CONSERVER POUR RÉFÉRENCE ULTÉRIEURE : LIRE ATTENTIVEMENT

- Le montage doit être effectué par un adulte. Le montage doit être vérifié par un adulte avant utilisation
- ATTENTION ! Tenir les vis, les petites pièces et les sachets en plastique hors de portée des enfants
- Identifiez correctement toutes les pièces avant de les assembler
- N'utilisez jamais votre article si l'une de ses pièces est cassée ou manquante
- En cas de problème, veuillez contacter notre service après-vente
- Les instructions du fabricant doivent être respectées à tout moment
- Entretien : nettoyer avec un chiffon doux et sec. En cas de taches plus importantes, frotter soigneusement avec une éponge non abrasive légèrement humide. légèrement humide et non abrasive
- Ne pas sauter sur le lit

Deutsch

WICHTIG ! ZUM SPÄTEREN NACHSCHLAGEN AUFBEWAHREN: SORGFÄLTIG LESEN

- Muss von einem Erwachsenen zusammengebaut werden. Der Zusammenbau muss vor dem Gebrauch von einem Erwachsenen überprüft werden
- WARNUNG! Bewahren Sie alle Schrauben, Kleinteile und Plastikbeutel außerhalb der Reichweite von Kindern auf
- Kennzeichnen Sie vor dem Zusammenbau alle Teile richtig.
- Benutzen Sie Ihren Artikel niemals, wenn Teile gebrochen sind oder fehlen
- Sollten Probleme auftreten, wenden Sie sich bitte an unseren Kundendienst
- Die Anweisungen des Herstellers sind stets zu befolgen
- Pflege: Mit einem weichen, trockenen Tuch reinigen. Bei größeren Flecken vorsichtig mit einem leicht feuchten, nicht scheuernden Schwamm abreiben. nicht scheuernden Schwamm
- Nicht auf das Bett springen

💡 More Tips 💡

1

English - Before installation, you can place the parts on a carpet or other soft fabric, in order to avoid damaging your floor.

Français - Avant l'installation, vous pouvez placer les pièces sur un tapis ou un autre tissu doux, afin d'éviter d'endommager votre sol.

Deutsch - Vor der Installation können Sie die Teile auf einen Teppich oder ein anderes weiches Material legen, um eine Beschädigung Ihres Fußbodens zu vermeiden.

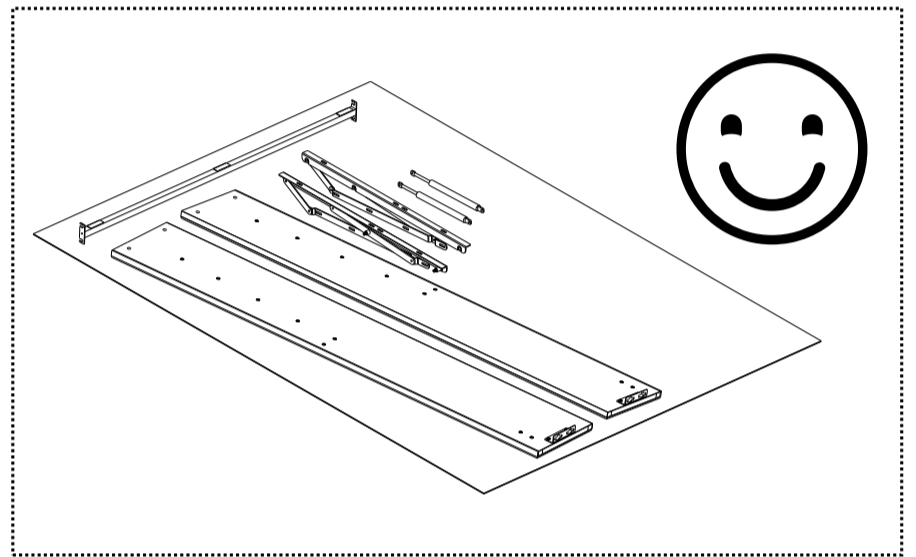
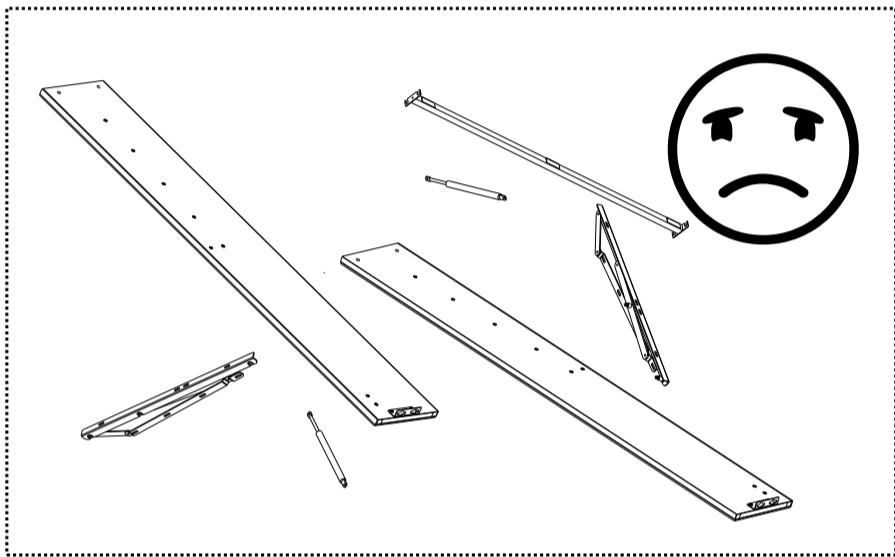

2

English - For your and your family's safety, please do not jump on beds, especially with hydraulic structures. When need to move bed, please work with more than one person to lift, not push, to avoid scratching your floor and hurting the stability of the bed.

Français - Pour votre sécurité et celle de votre famille, ne sautez pas sur les lits, en particulier sur les structures hydrauliques. Lorsqu'il est nécessaire de déplacer le lit, il est préférable de travailler à plusieurs pour le soulever, et non pour le pousser, afin d'éviter de rayer le sol et de nuire à la stabilité du lit.

Deutsch - Zu Ihrer Sicherheit und der Ihrer Familie sollten Sie nicht auf Betten springen, insbesondere bei hydraulischen Konstruktionen. Wenn Sie das Bett bewegen müssen, heben Sie es bitte mit mehreren Personen an und schieben Sie es nicht, um den Boden nicht zu verkratzen und die Stabilität des Bettes nicht zu beeinträchtigen.

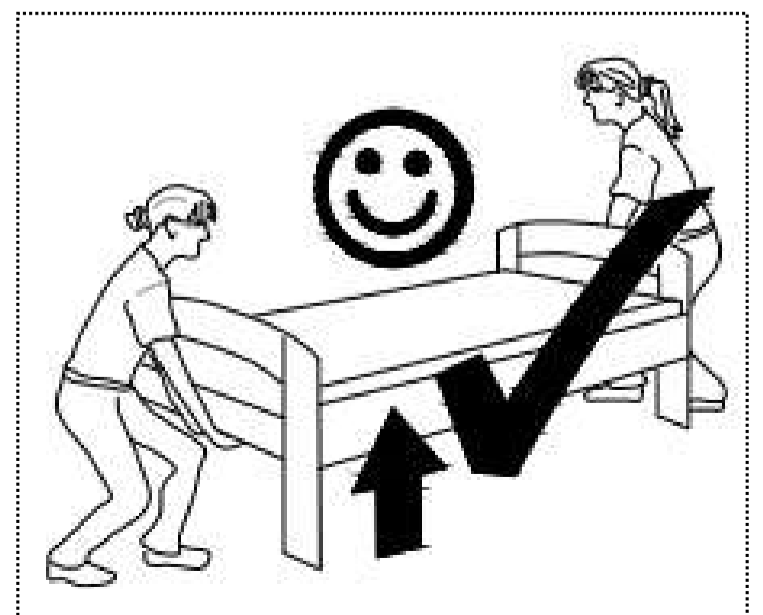
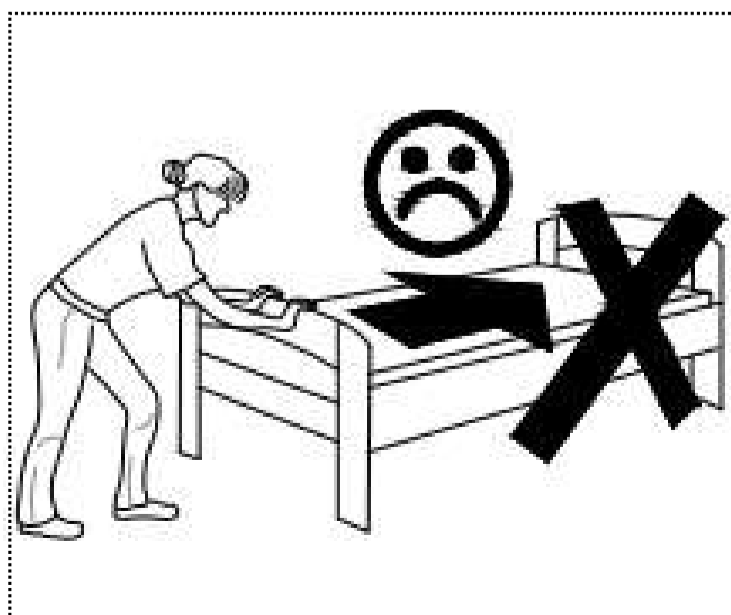

Stückliste

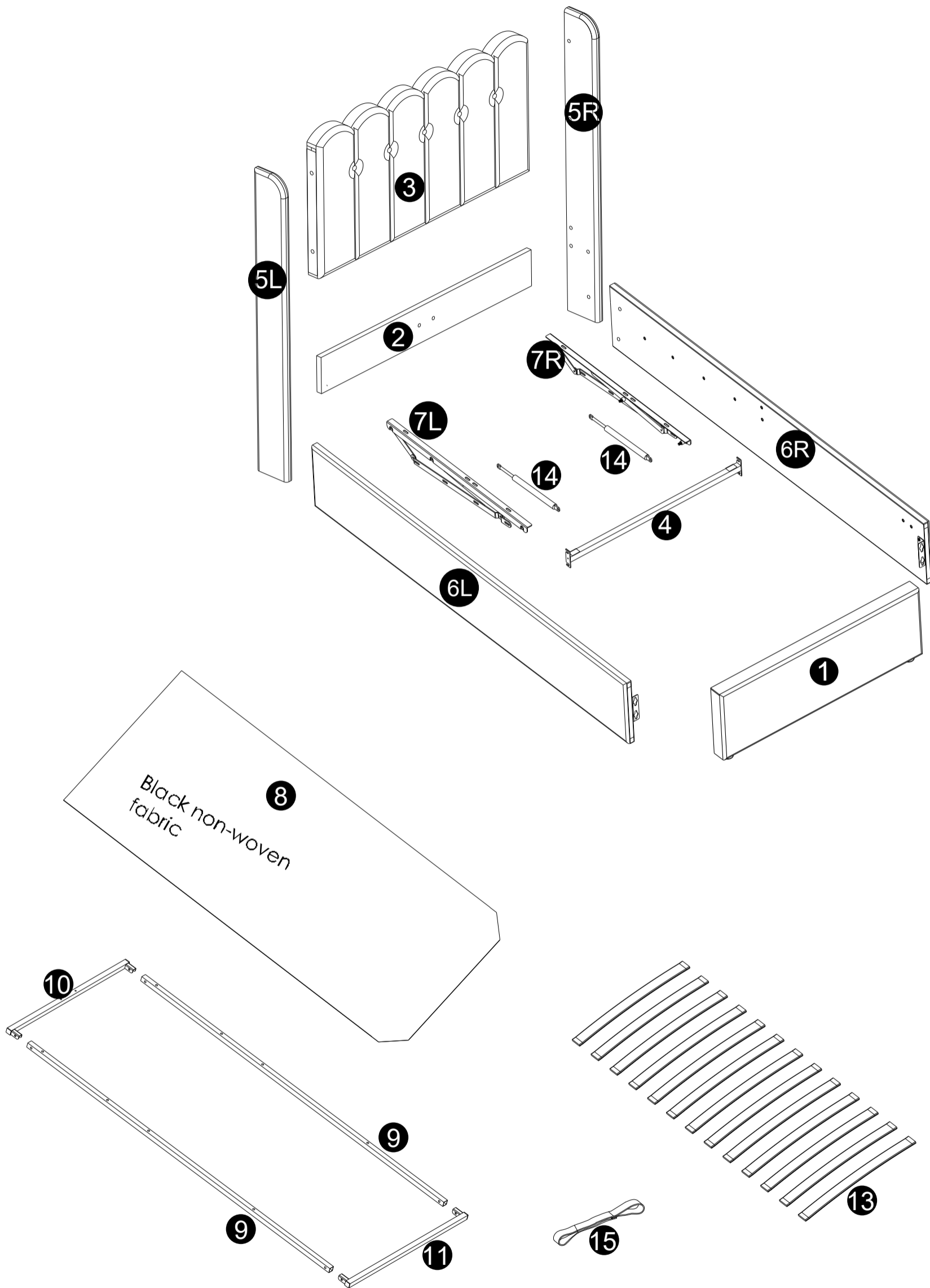

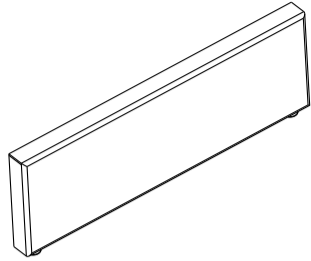
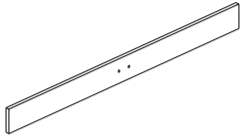

WF312933

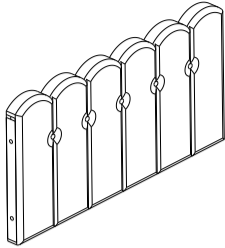
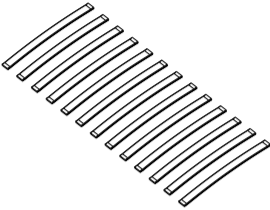
1		X1
2		X1

3		X1
13		X1

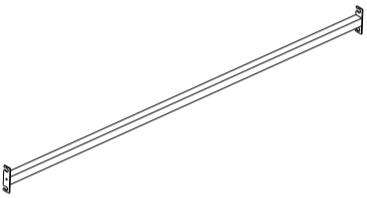
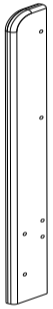
WF312934

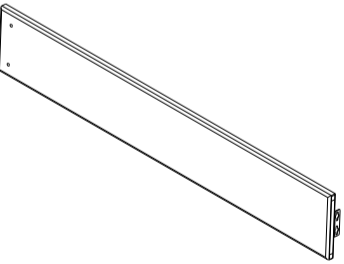
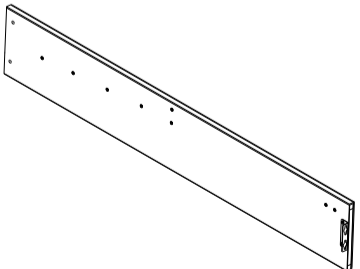

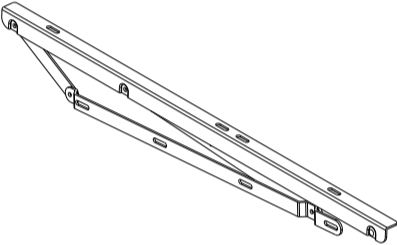
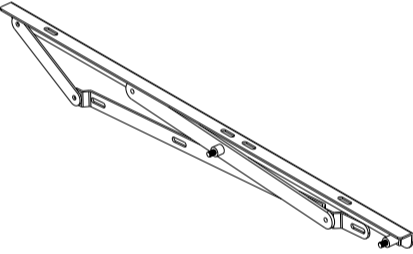
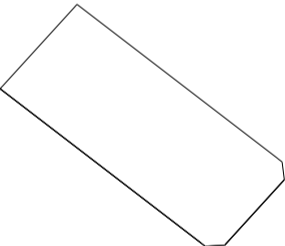
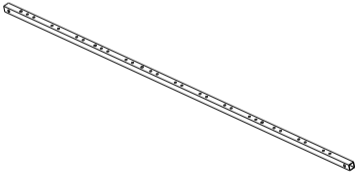
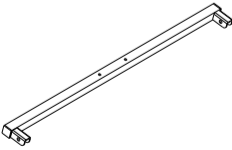
4		X1
5L		X1
5R		X1
6L		X1
6R		X1

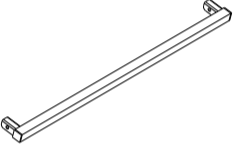
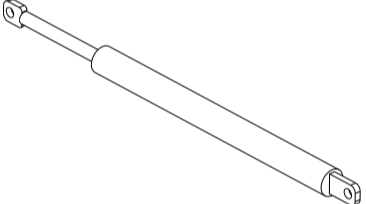
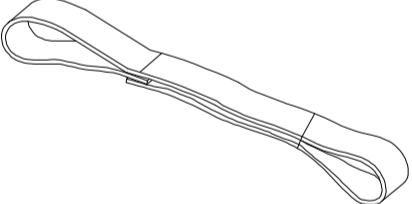
7L		X1
7R		X1
8		X1
9		X2
10		X1

11		X1
14		X2
15		X1

Hardware List-Hardware-Liste-Liste du matériel

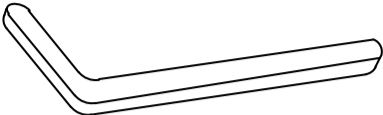
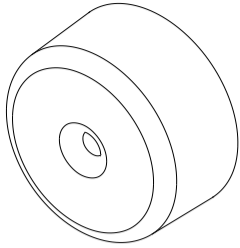
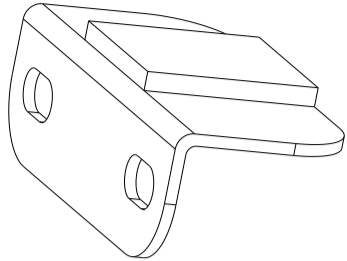
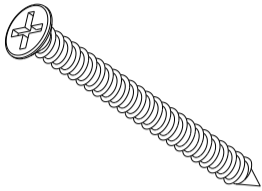
WF312934

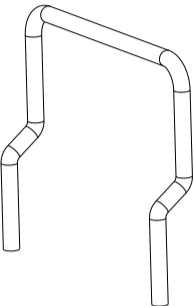
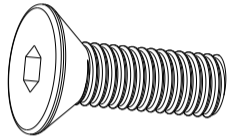
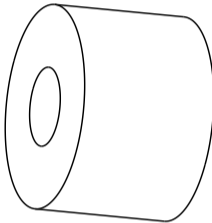
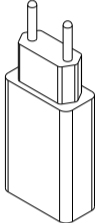
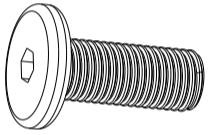
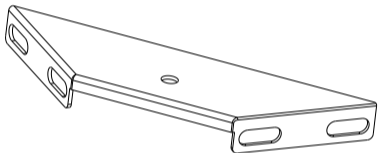
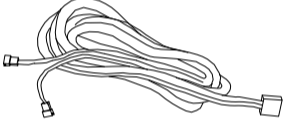
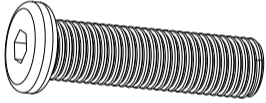
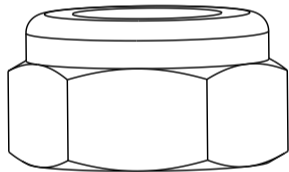
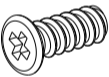
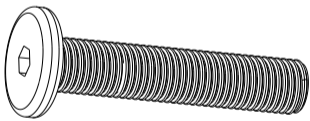
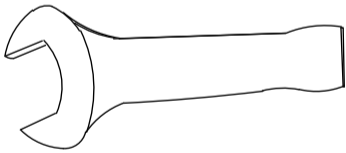
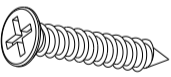
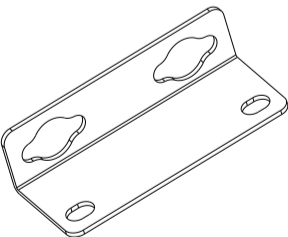
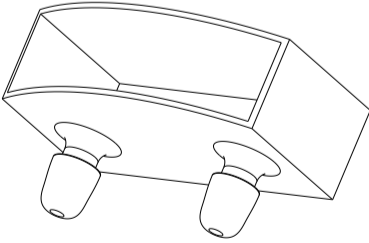
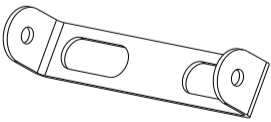
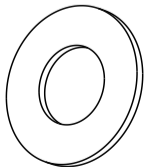
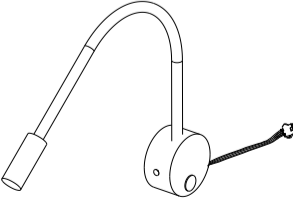
A		X1	K		X2	T		X2
B	 M4x40mm	X2	L		X1	U		X1
D	 M8x18mm	X4	M		X8	V		X1
E	 M8x20mm	X24	N		X2	W		X1
F	 M8x30mm	X8	O	 M8	X14	X		X4
G	 M8x40mm	X18	P		X1	Y		X4
H		X2	Q		X26	Z		X2
J		X12	R		X1			

1

A x 1



E x 4



M8 x 20mm

H x 2

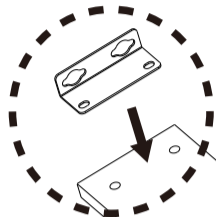
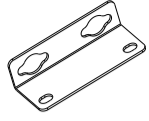

2

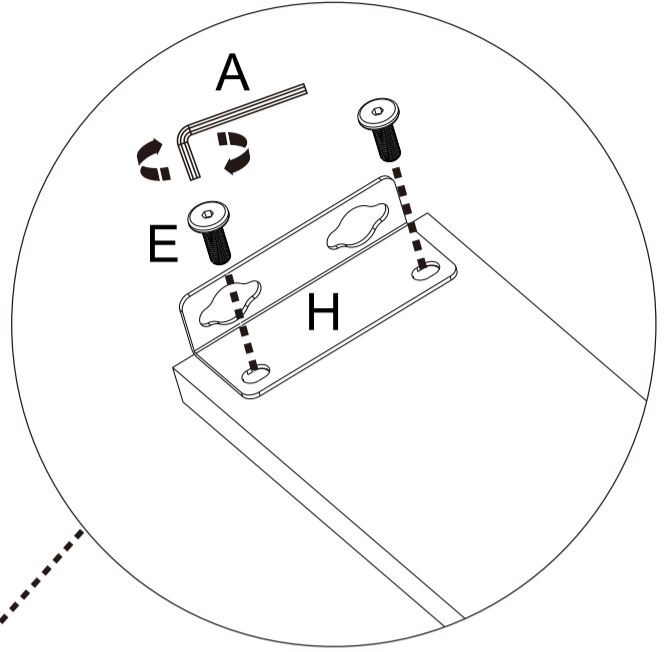
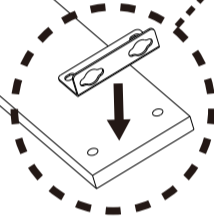

2

A x 1



E x 4



M8 x 20mm

G x 4



M8 x 40mm

J x 4

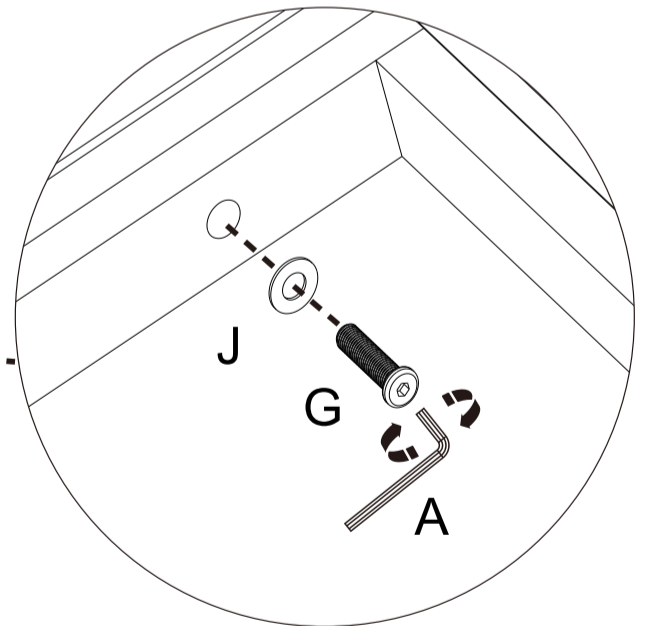
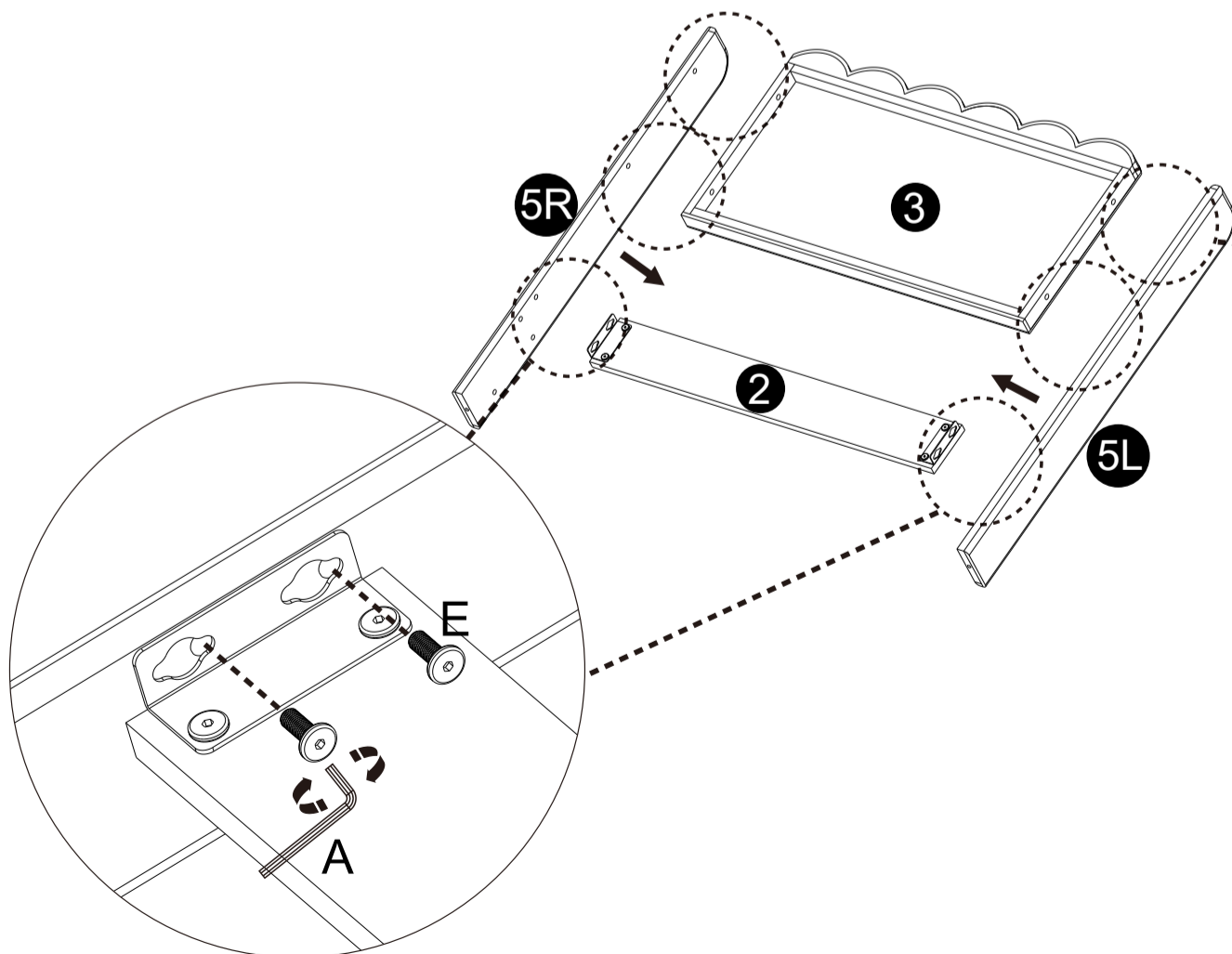

3

A x 1



B x 2



M4 x 40mm

E x 4



M8 x 20mm

K x 2

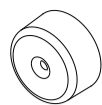

T x 2

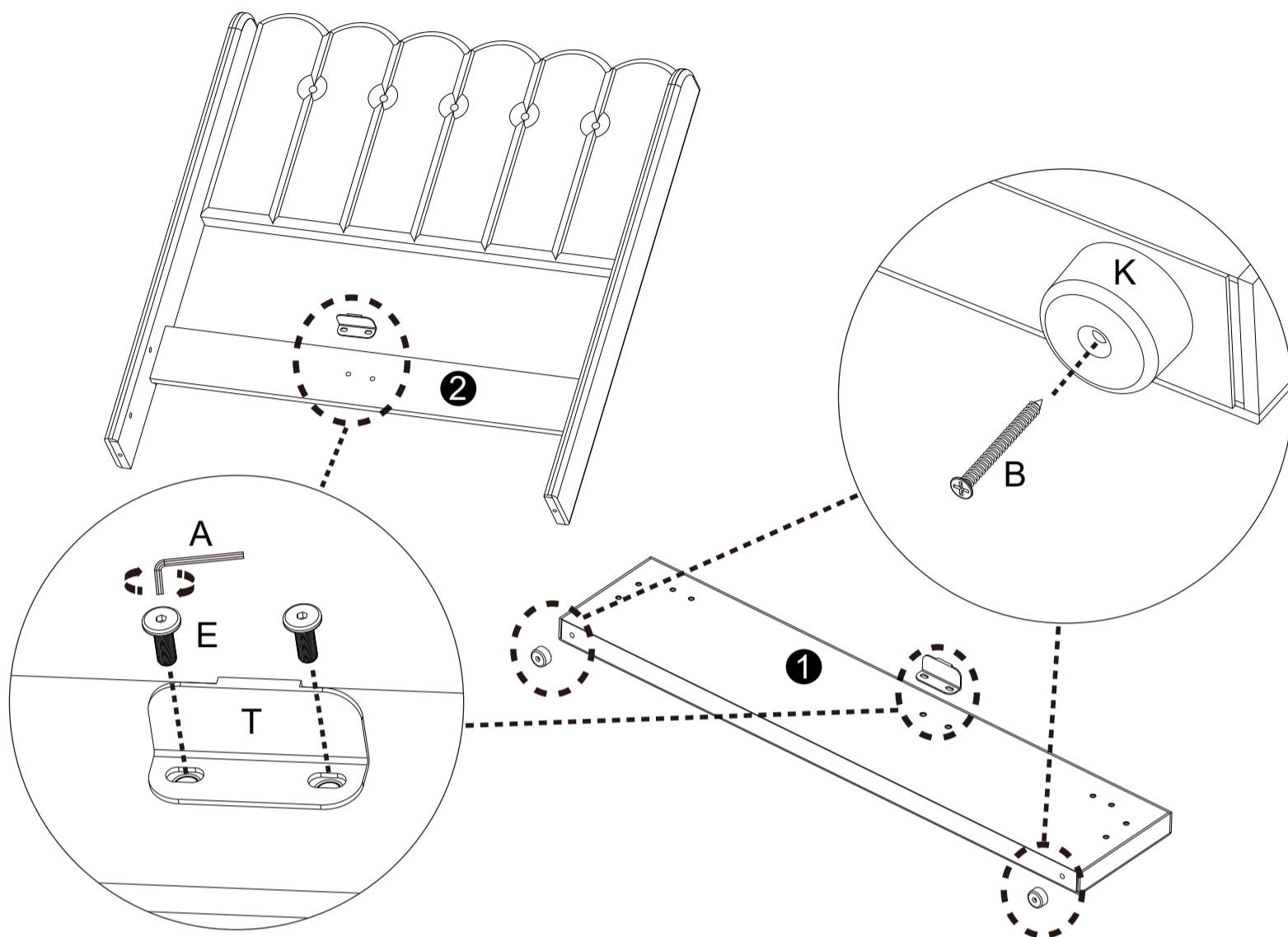
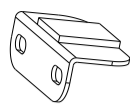

4

A x 1





E x 4



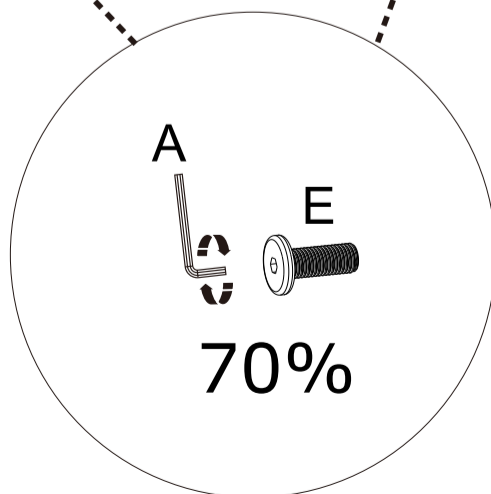
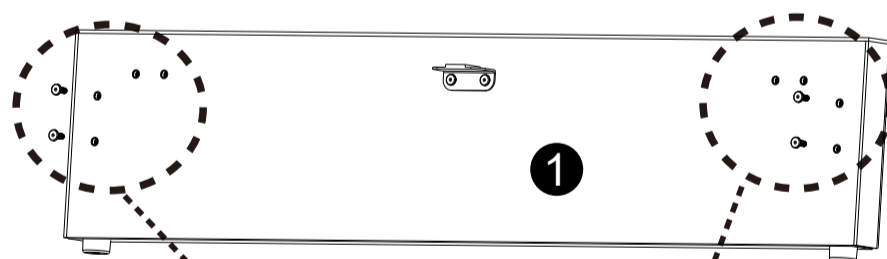

M8 x 20mm



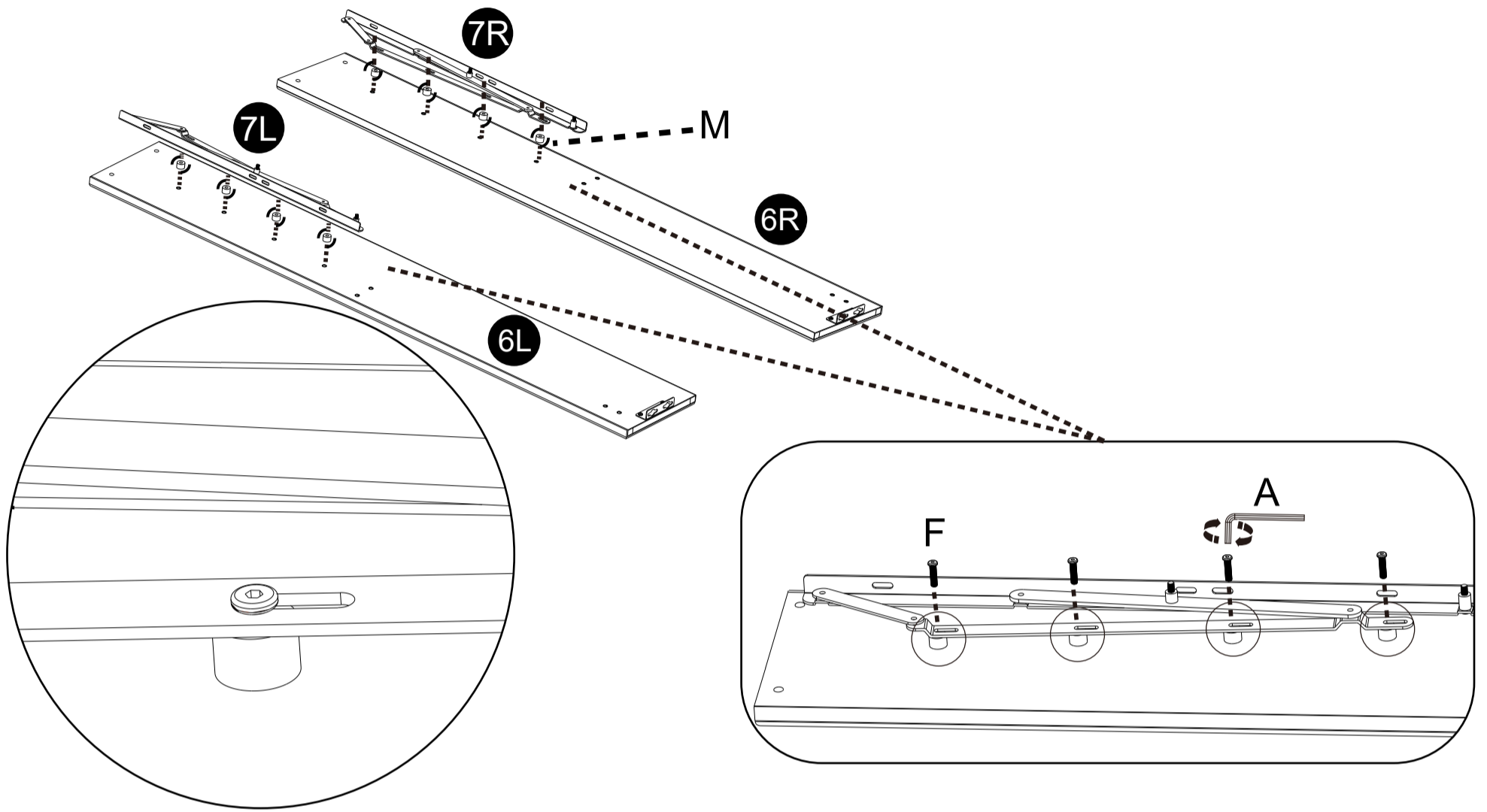

5	A x 1	F x 8	M x 8
		 M8 x 30mm	



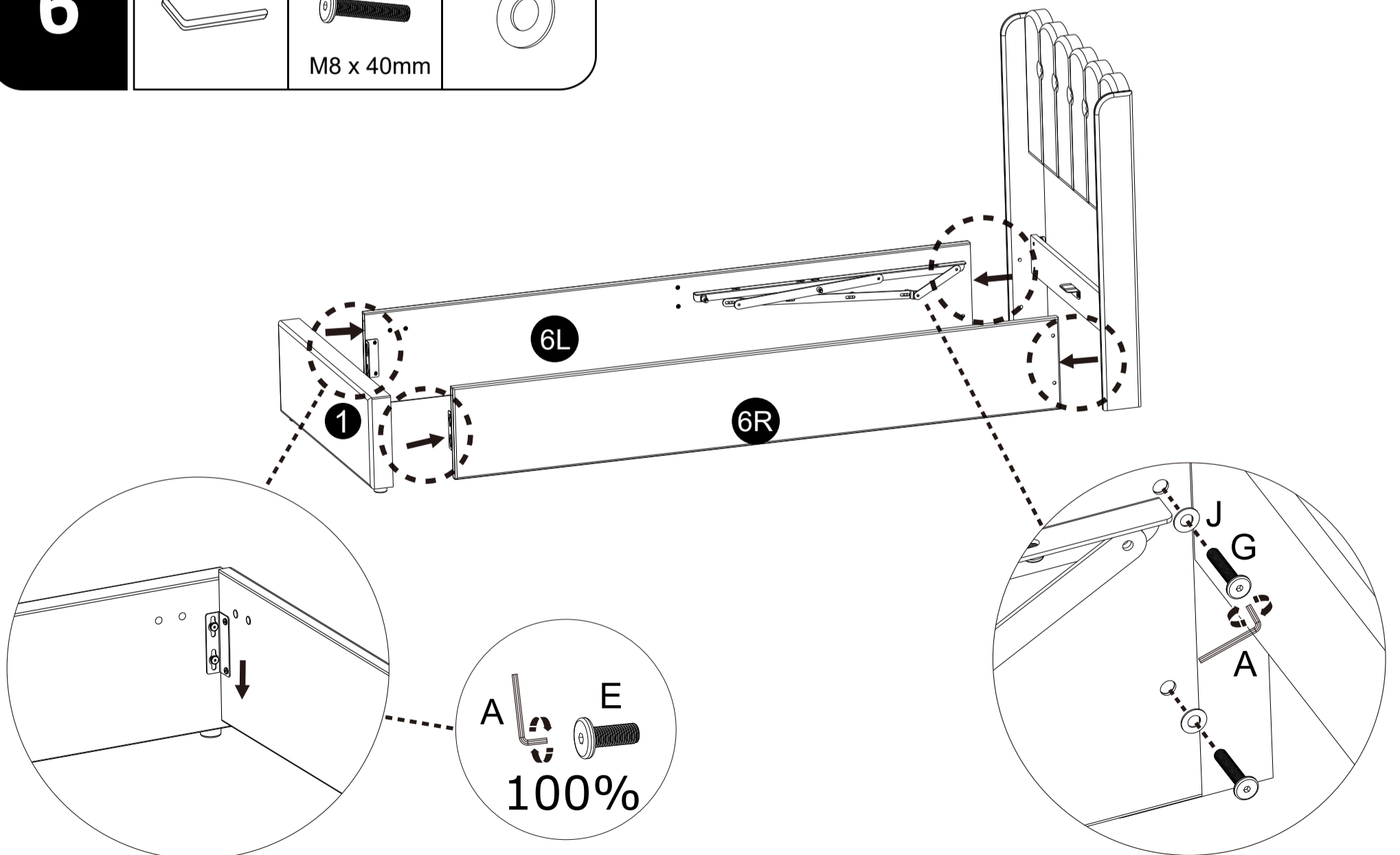

6	A x 1	G x 4	J x 4
		 M8 x 40mm	

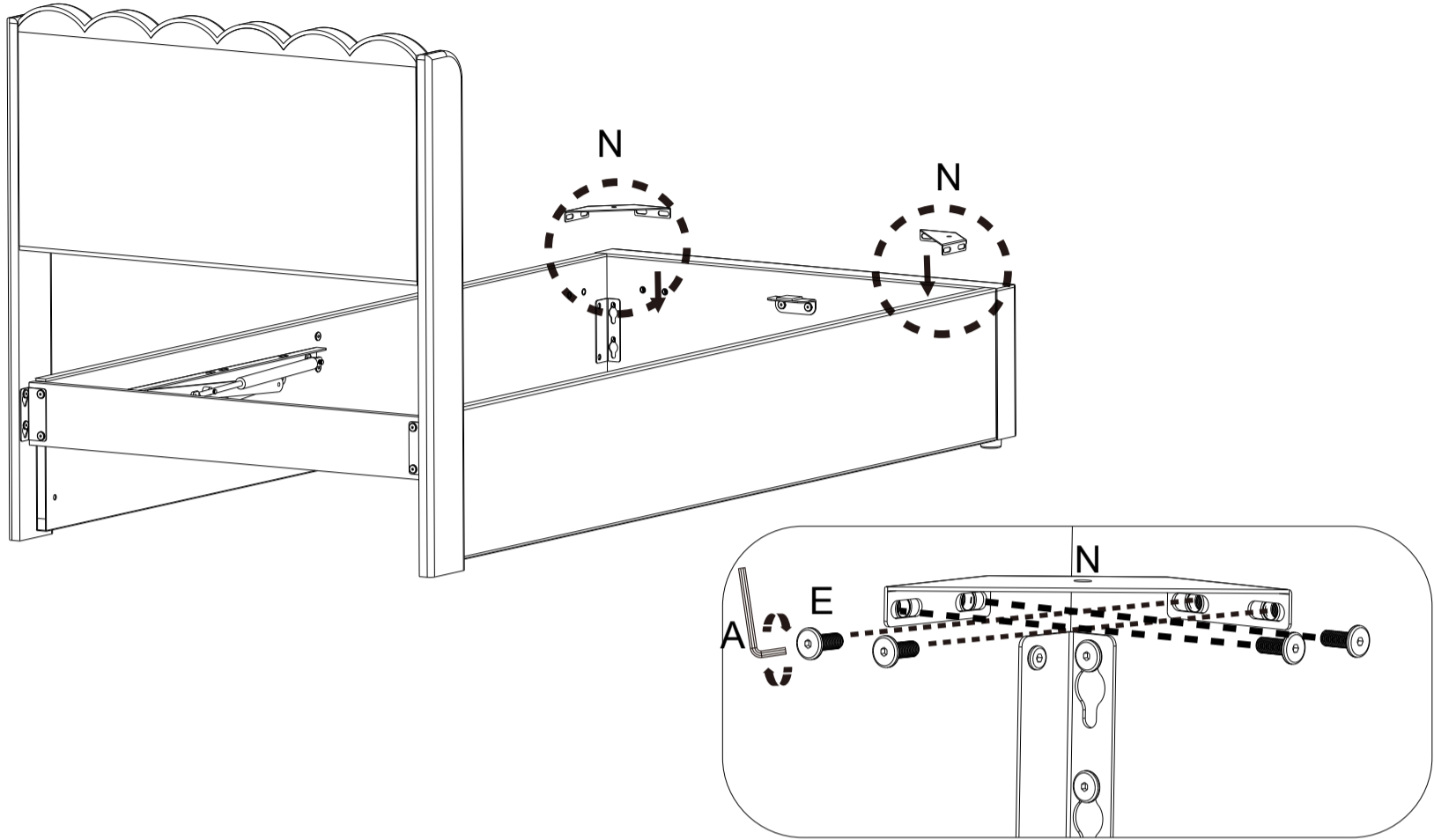

7	A x 1	E x 8	N x 2
		 M8 x 20mm	



8	A x 1	D x 4
		 M8 x 18mm

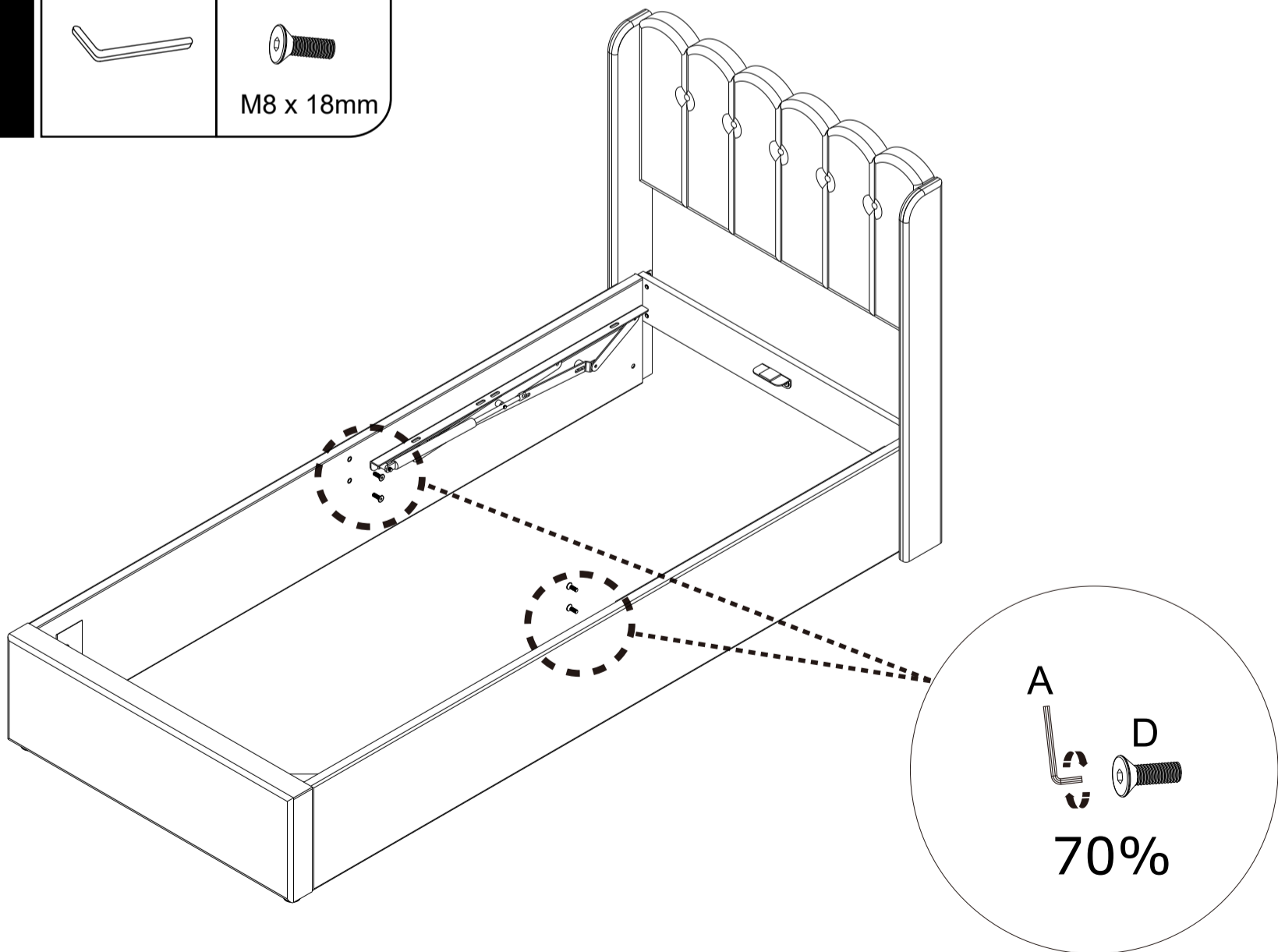

9

A x 1

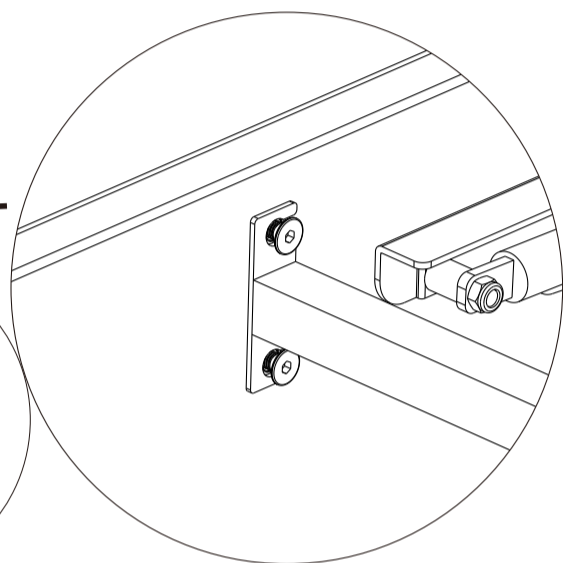
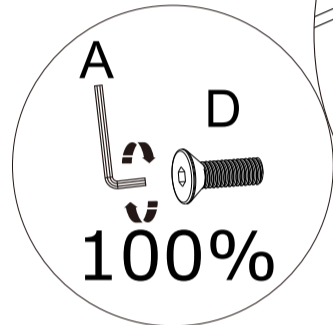
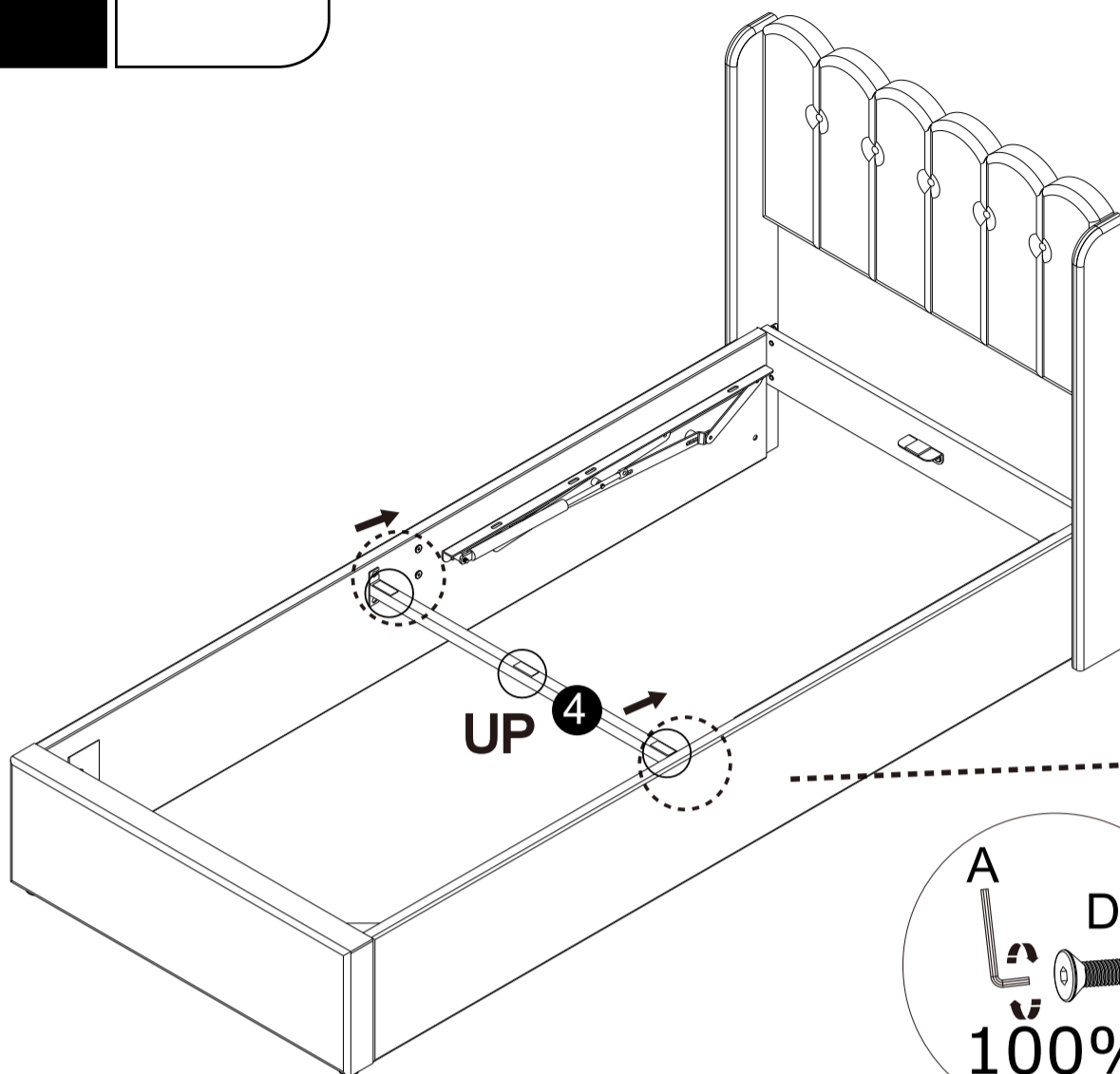

10

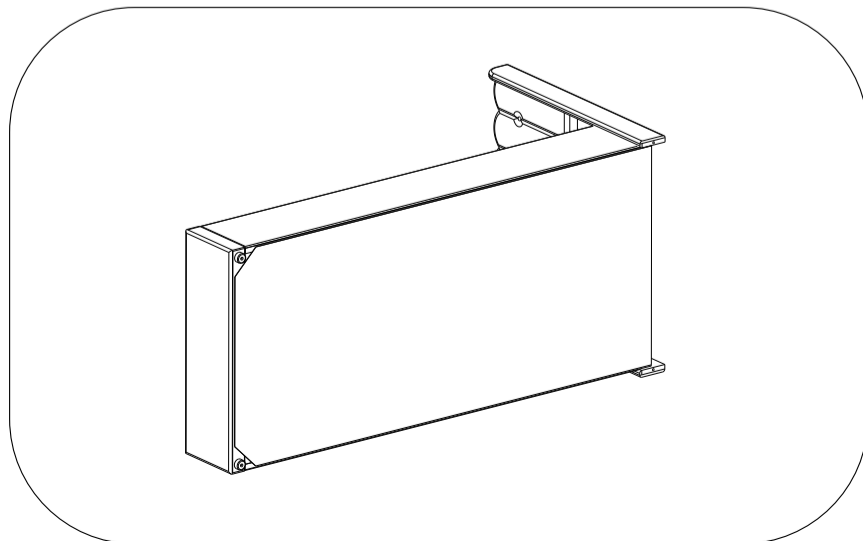
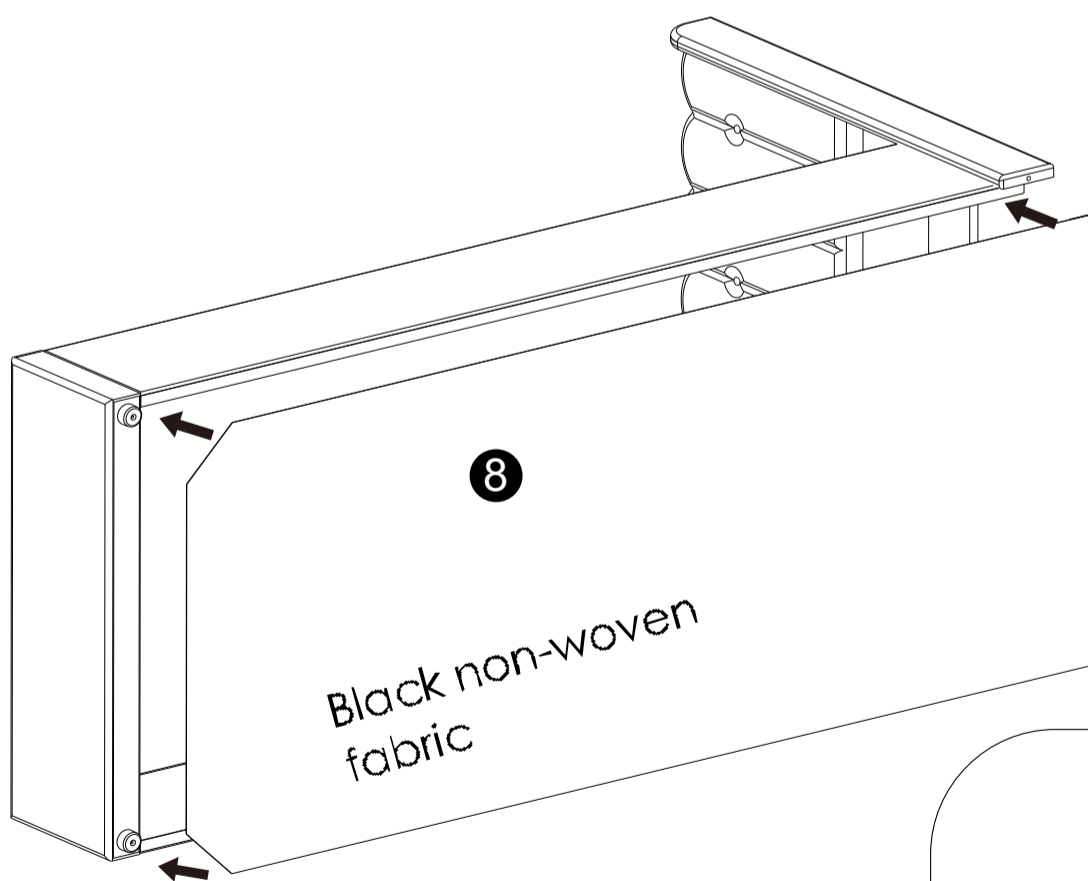

11

A x 1



G x 4



M8 x 40mm

J x 4

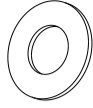

O x 4

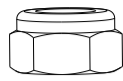

P x 1



!!! Please aware the orientation of the holes on #9
!!!Bitte beachten Sie die Ausrichtung der Löcher auf #9
!!! Attention à l'orientation des trous sur le #9

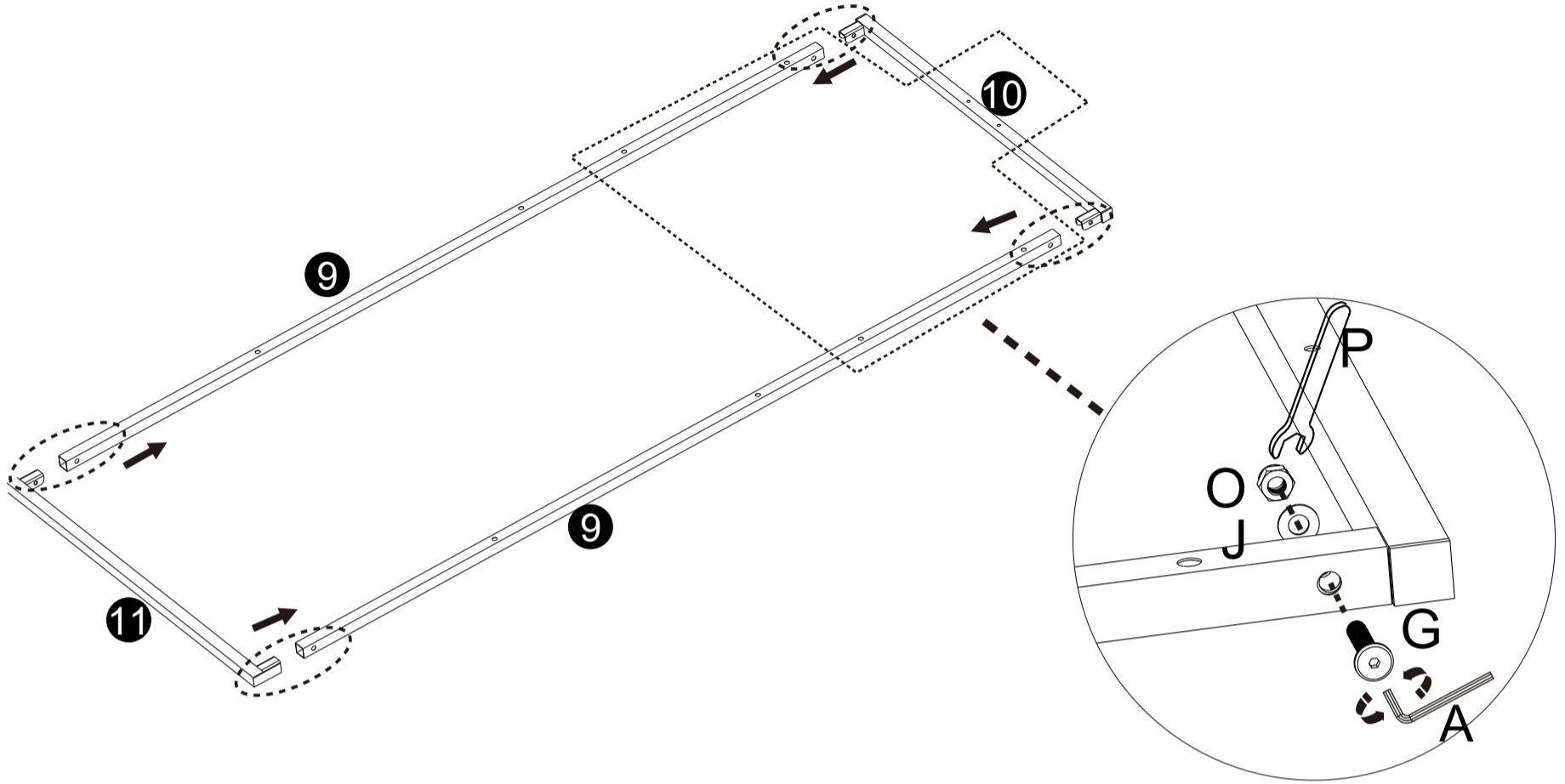

12

A x 1



G x 6



M8 x 40mm

O x 6

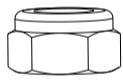

P x 1

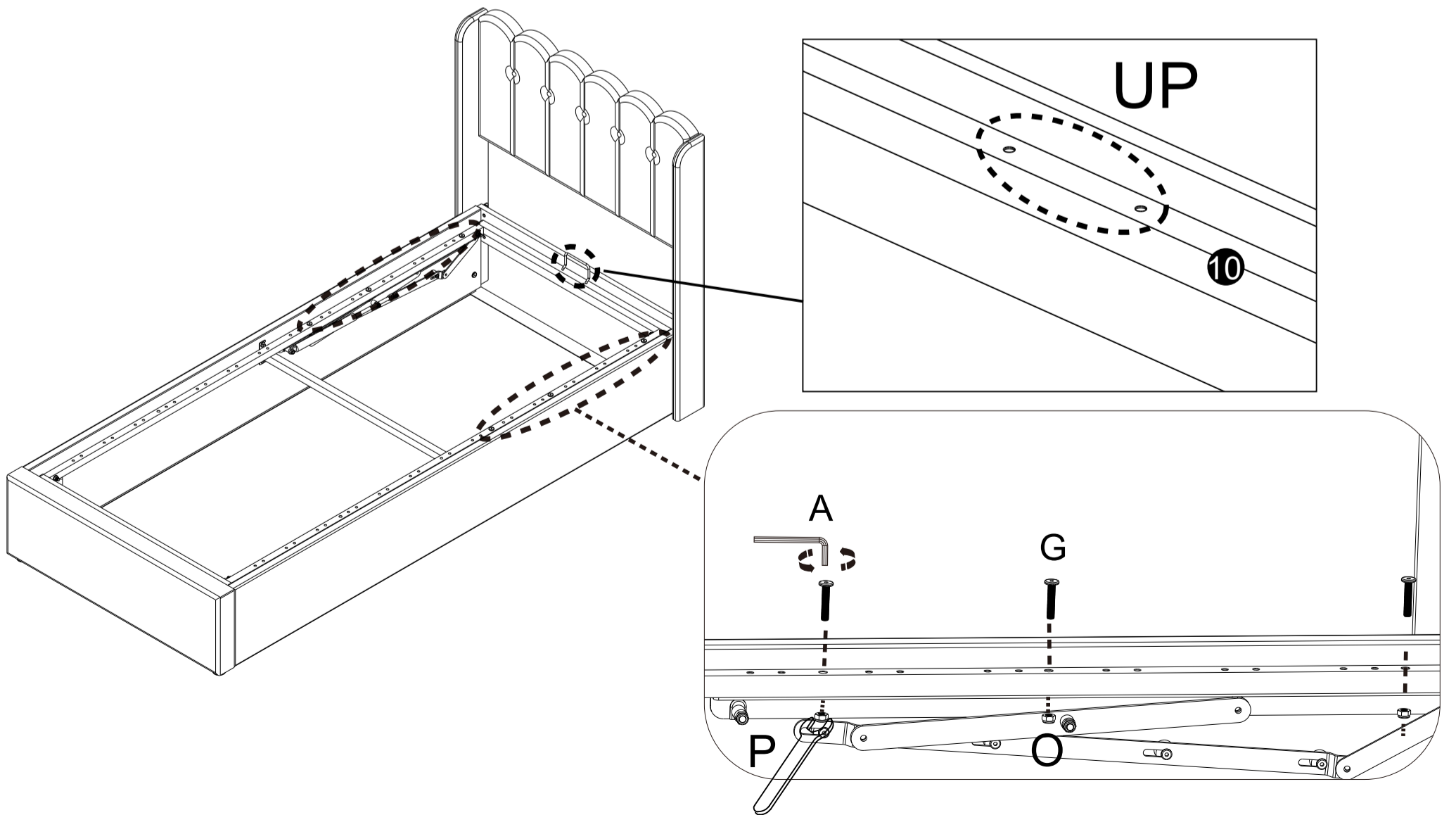
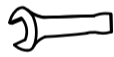

13

U x 1

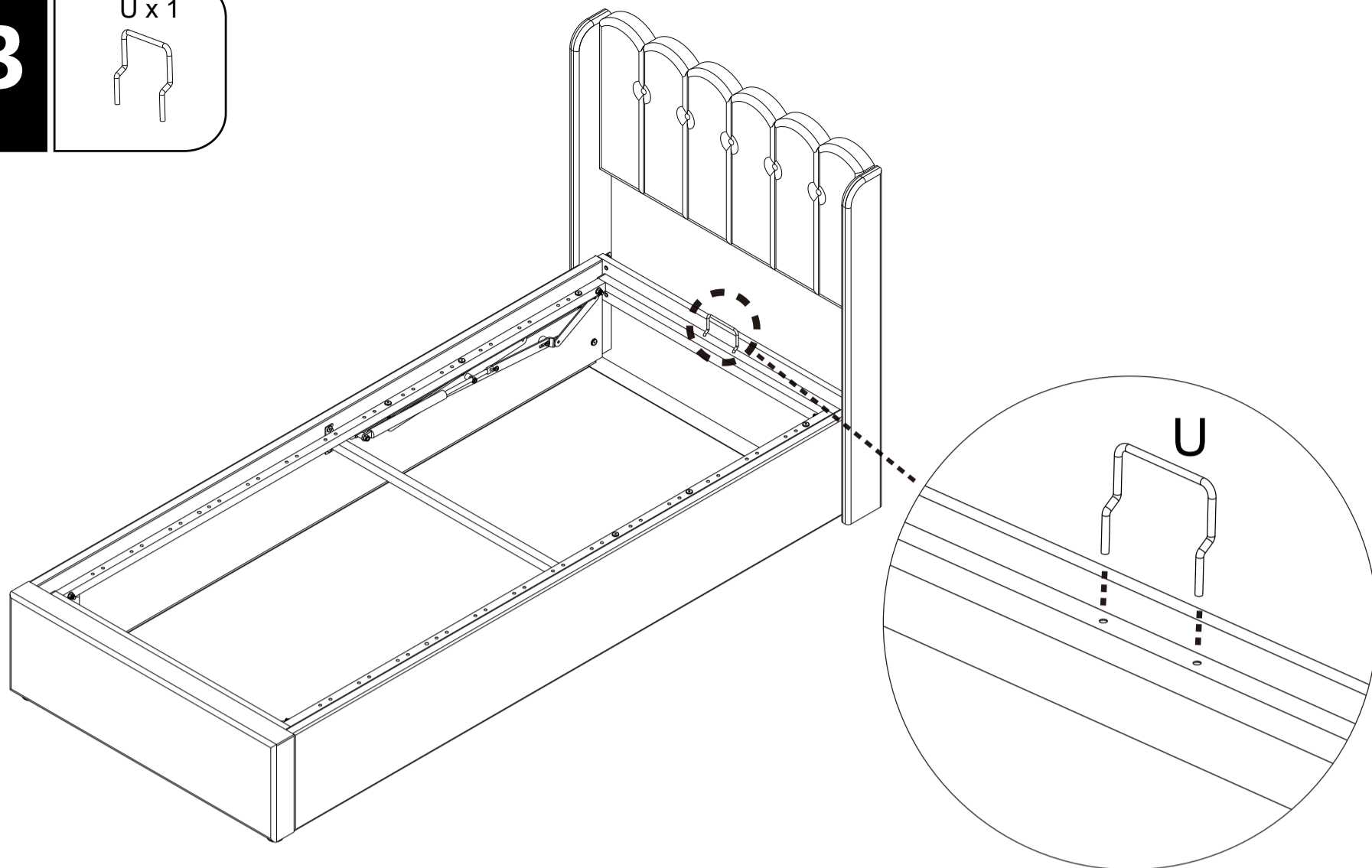
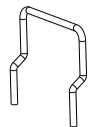

14

Q x 26

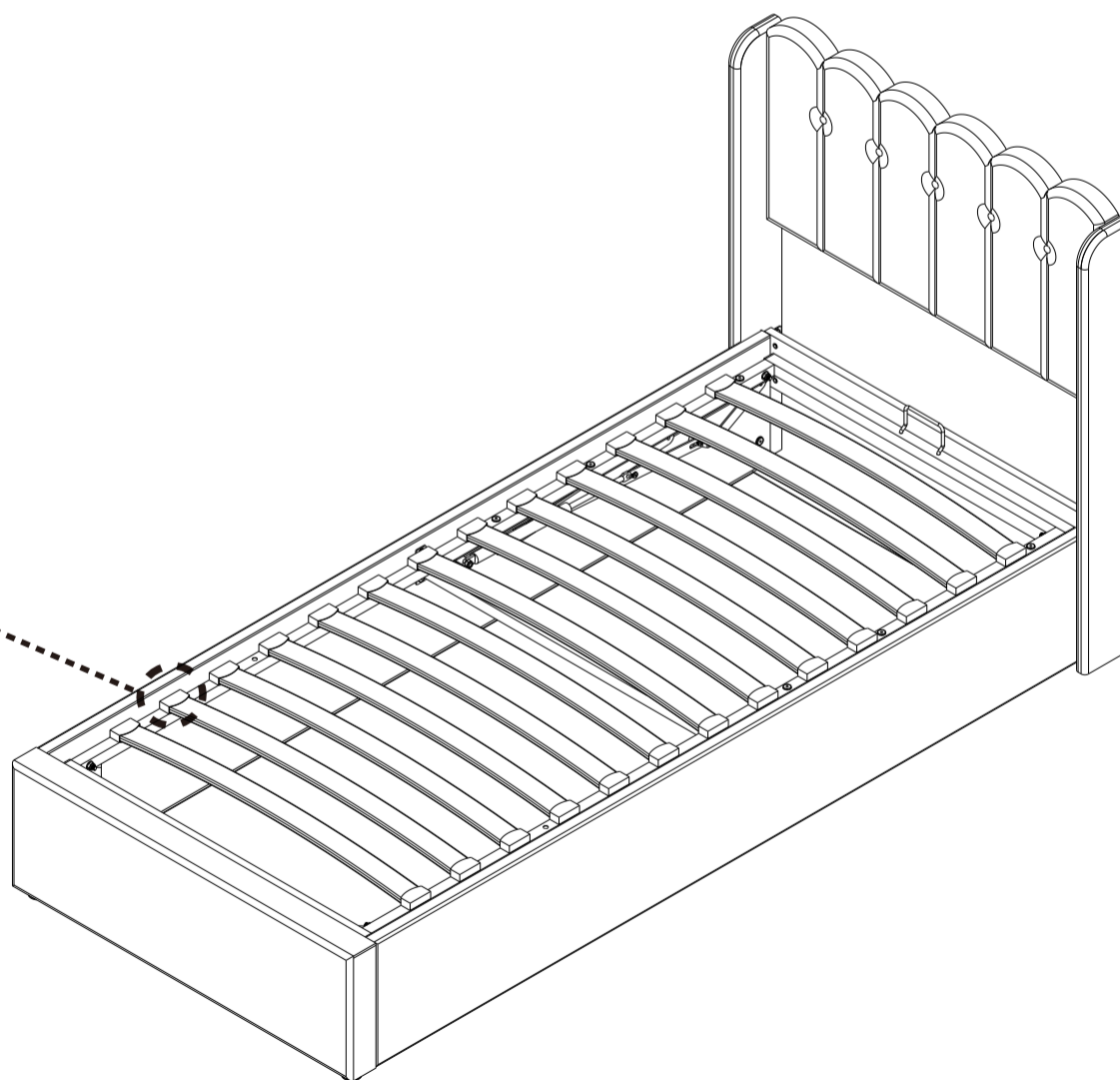
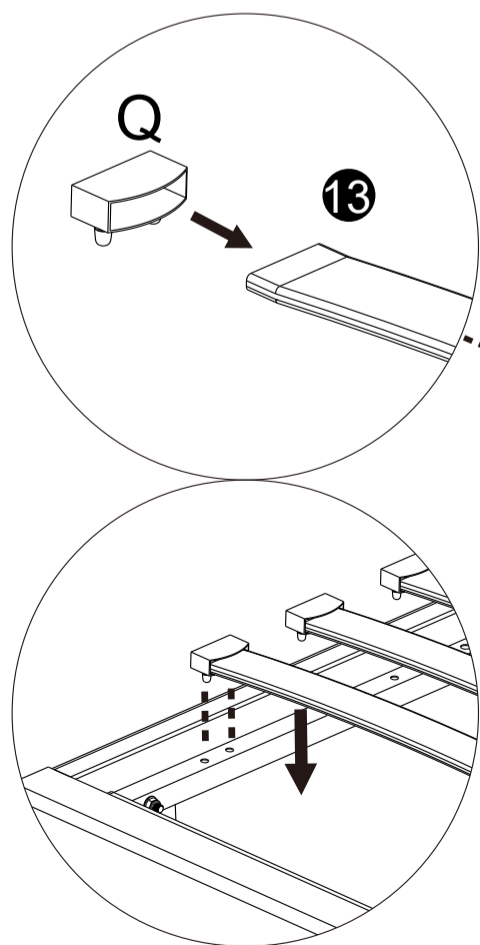

15

O x 4

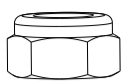

P x 1

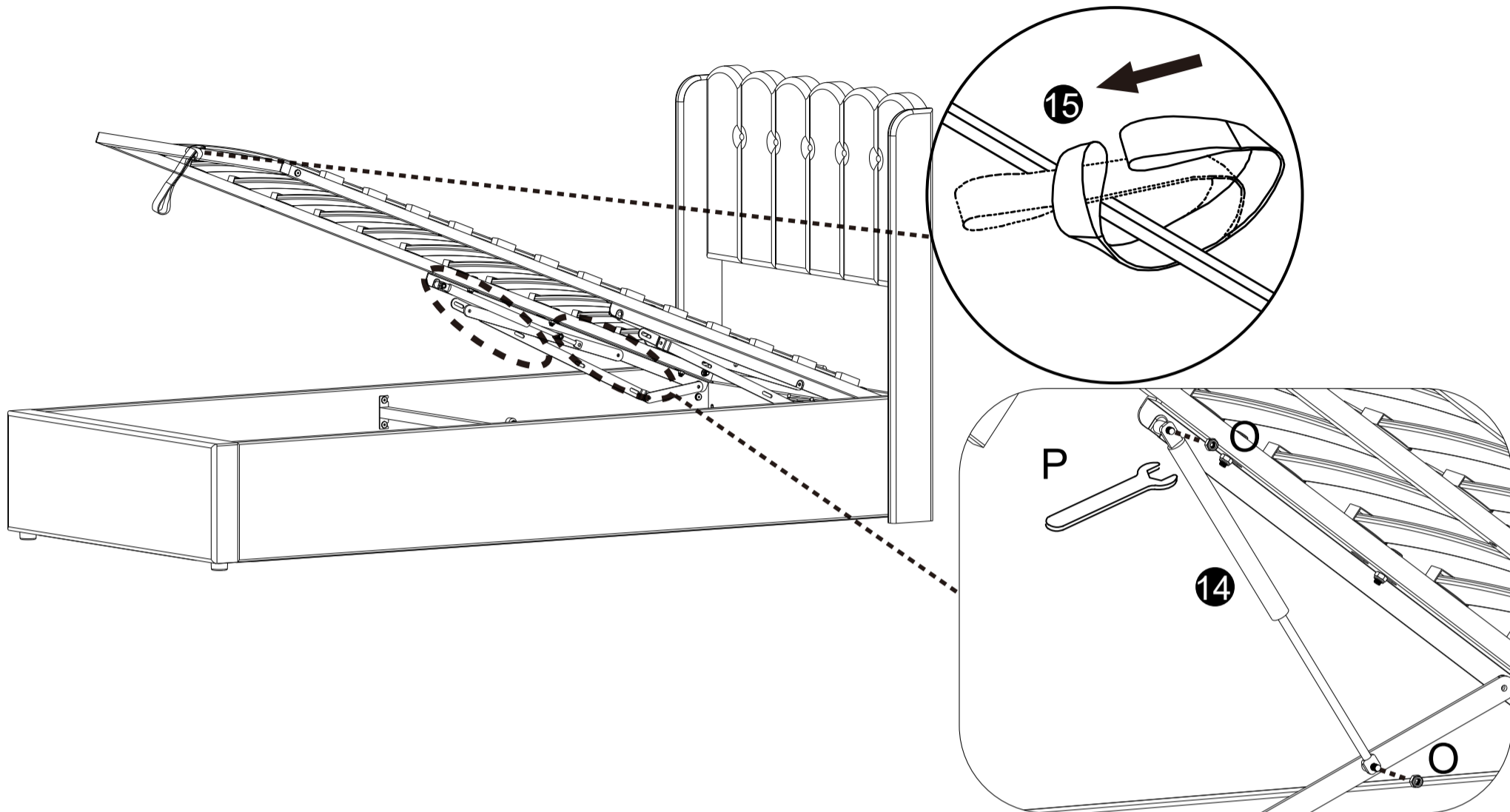

16

Y x 4

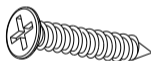

Z x 2

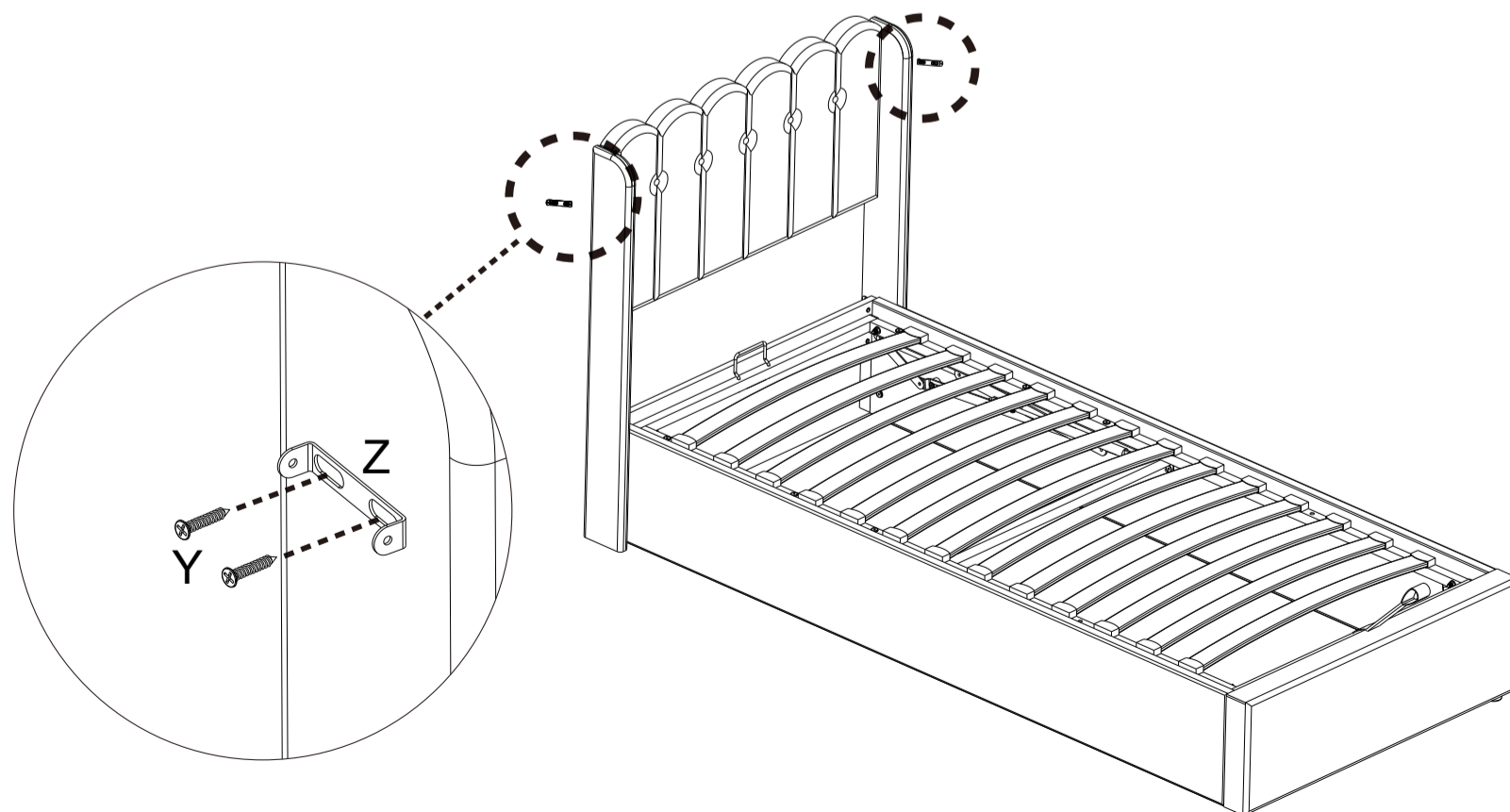

17

L x 1



R x 1



V x 1

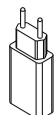

W x 1



X x 4

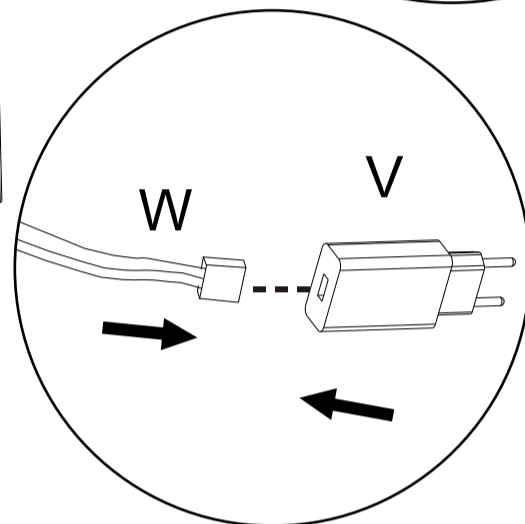
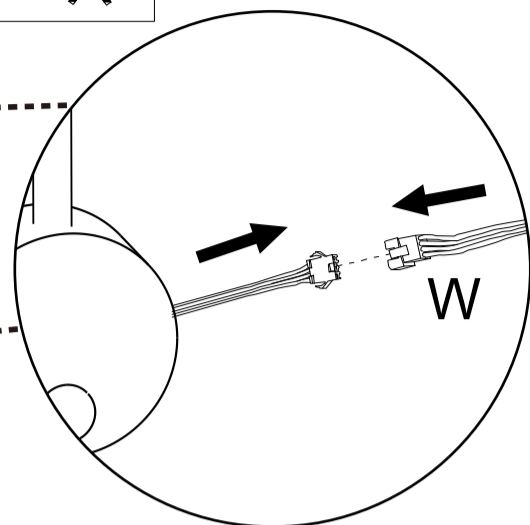
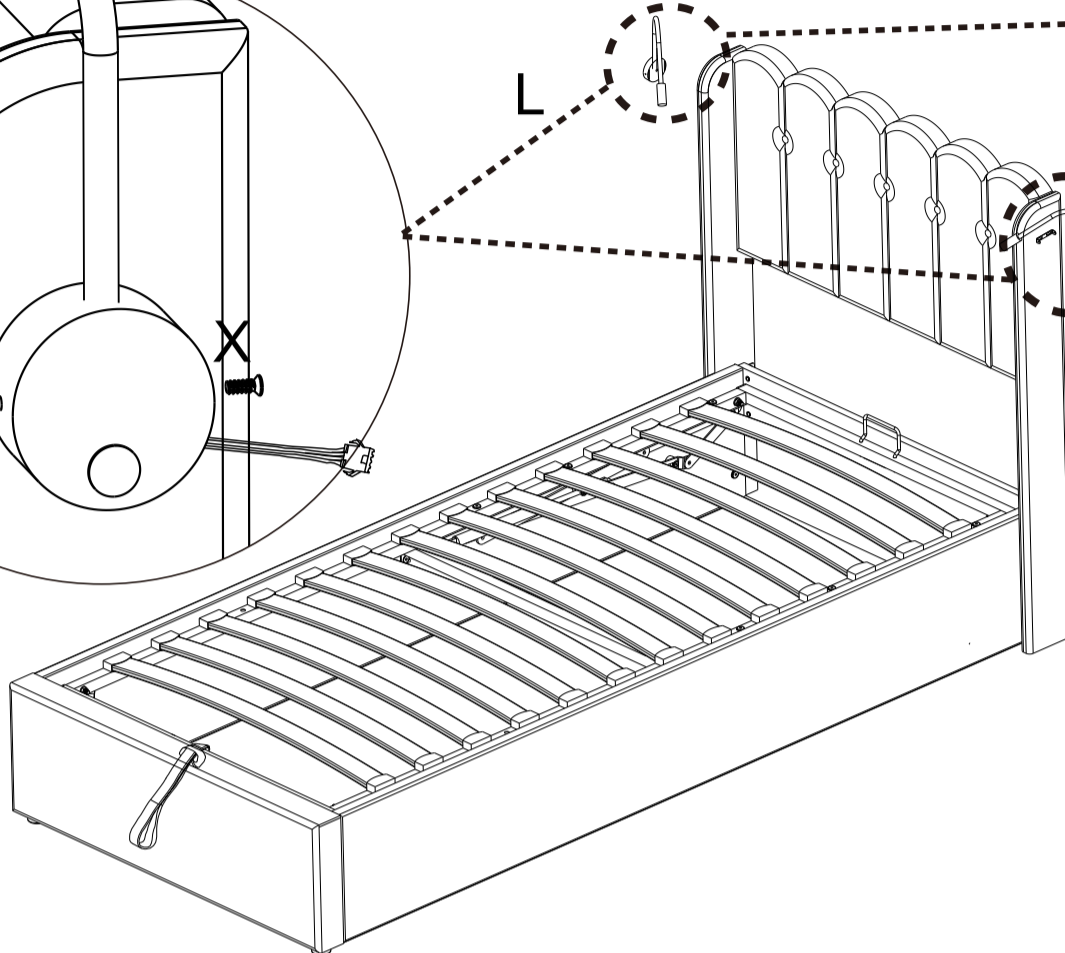
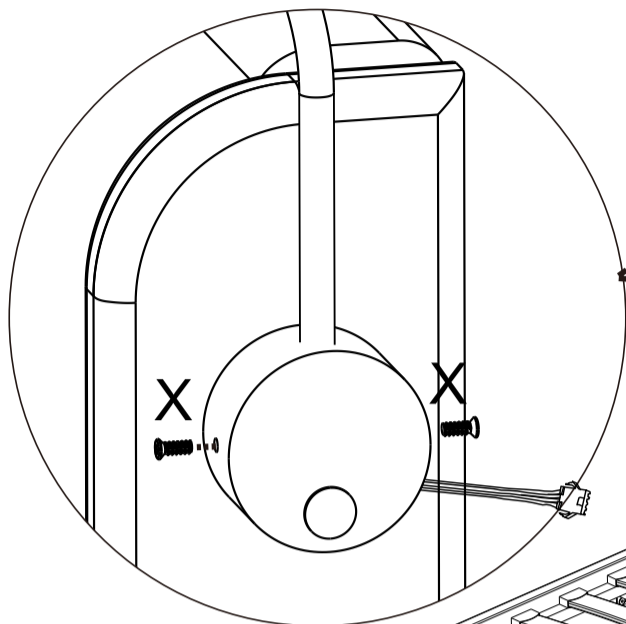
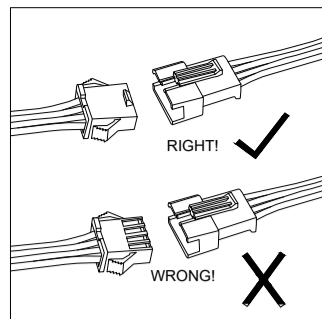
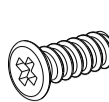

18

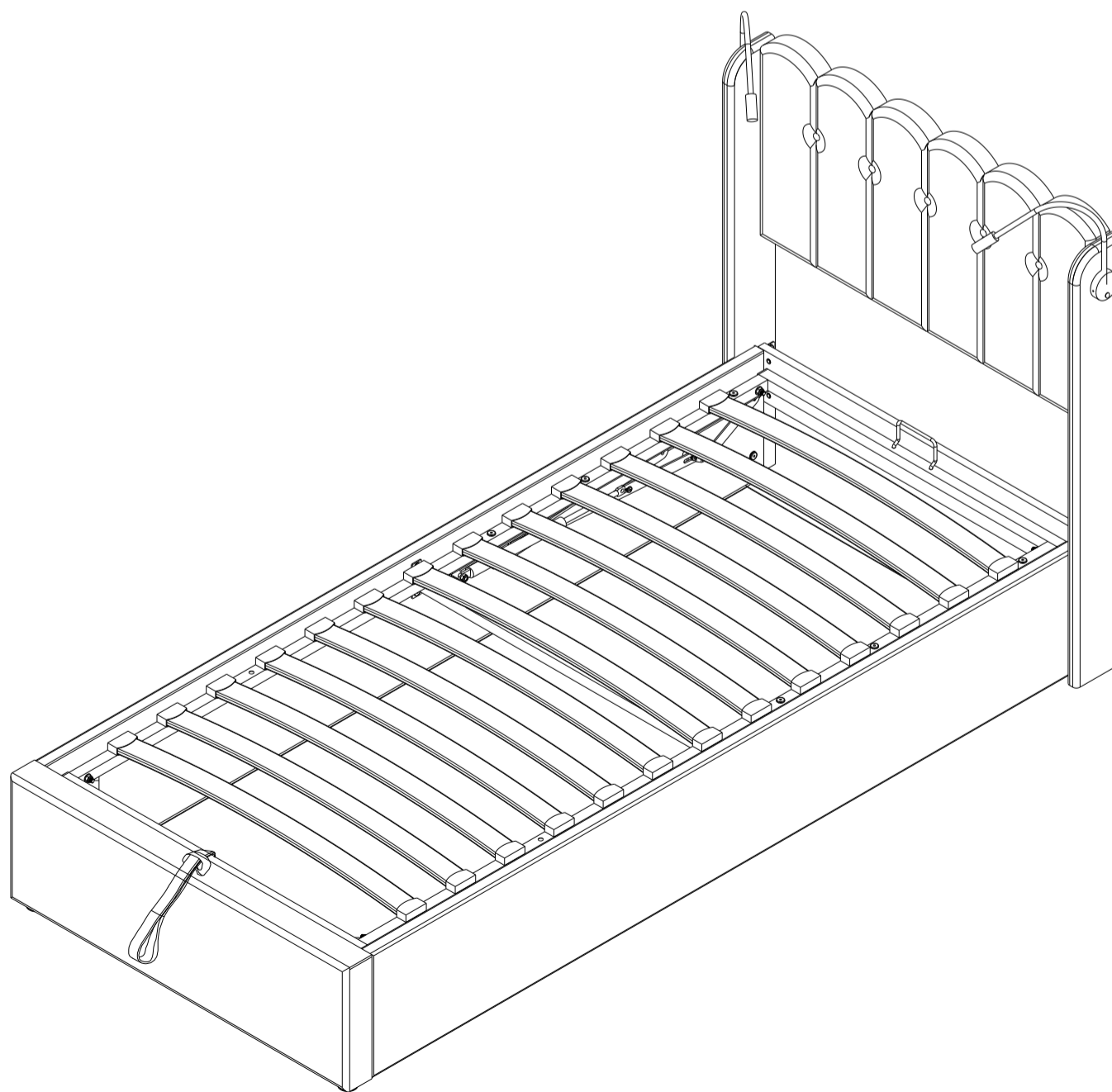

★ IMPORTANT NOTICE ★

HYDRAULIC BED OPERATING INSTRUCTIONS

Once your bed frame is completely assembled, the slat unit will not operate correctly unless a mattress is placed on the slat frame. Position the mattress on the slat frame whilst it is in the closed position.

PLEASE NOTE - It takes a lot of force to make the initial movement of the ottoman. This is a design feature of the product so that it does not fall shut the nearer to being closed the ottoman is, the easier it is to move. When the ottoman is almost shut, it will close completely under its own weight.

When lowering the slat unit for the first time, take care to make sure it does not rub unevenly on the inside face of the side rails. If it does, the bed has been assembled slightly out of square. This can be rectified by moving the foot end of the bed slightly to the left or right whilst leaving the head end stationary.

PISTONS

The pistons used in the construction of this product are extremely strong and cannot be operated by hand when taken off the ottoman. All pistons are tested for correct pressure and operation before being attached to the slat unit.

Initially it might appear that the pistons are very stiff when opening and closing the ottoman.

THIS IS PERFECTLY NORMAL

When fully assembled and the mattress is in position, please raise and lower the ottoman 4/5 times to ensure the gas piston are fully lubricated.

