

# CHAMBORD 55

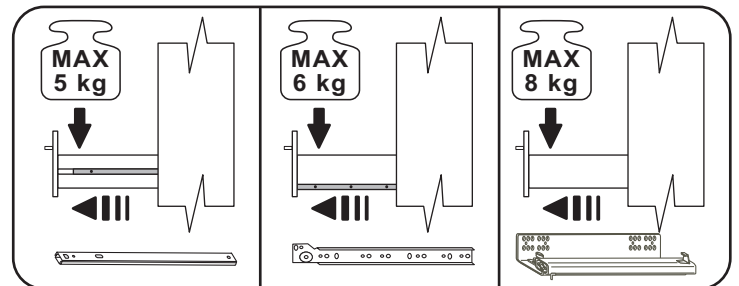

# CHAMBORD 55

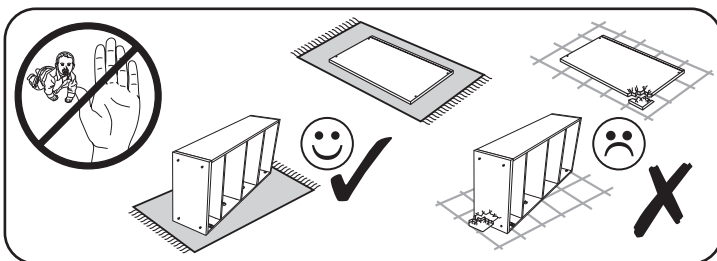
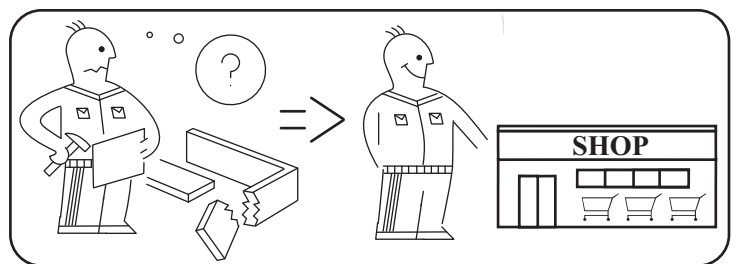
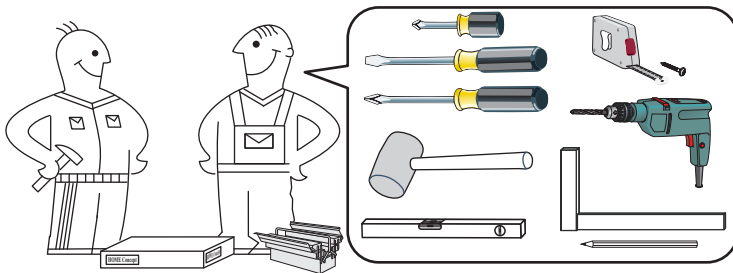
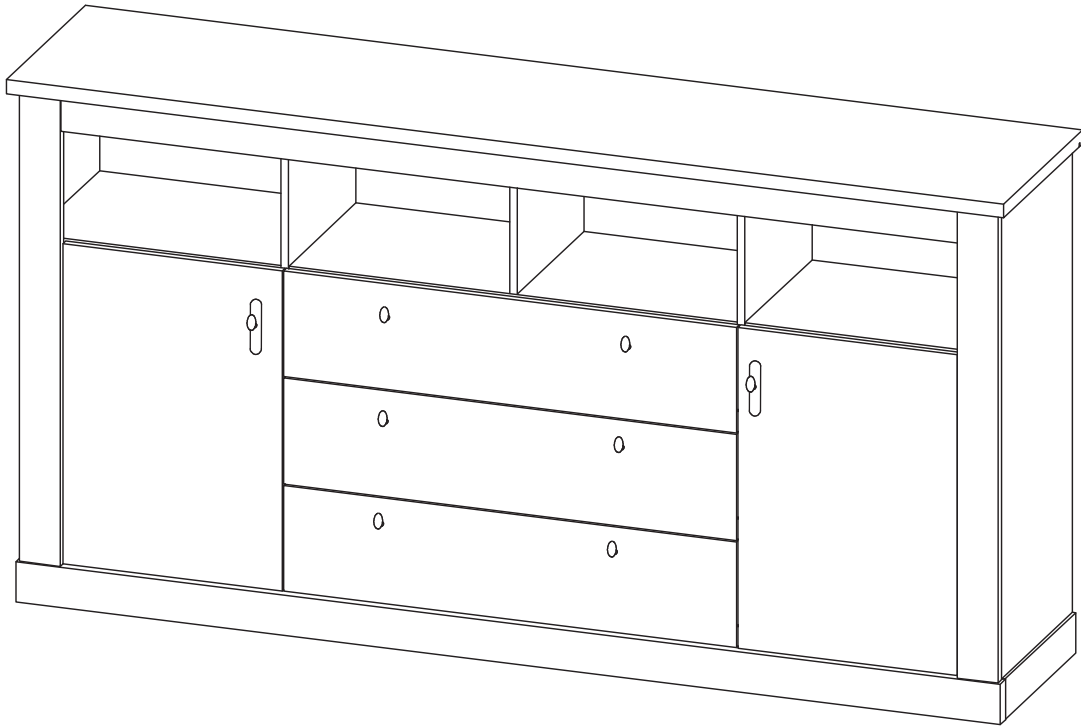
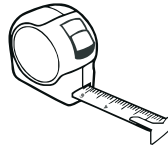
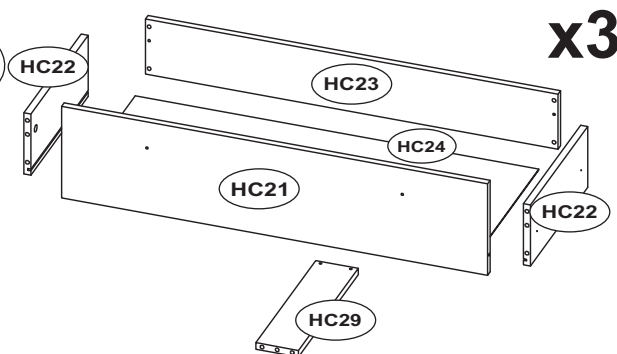
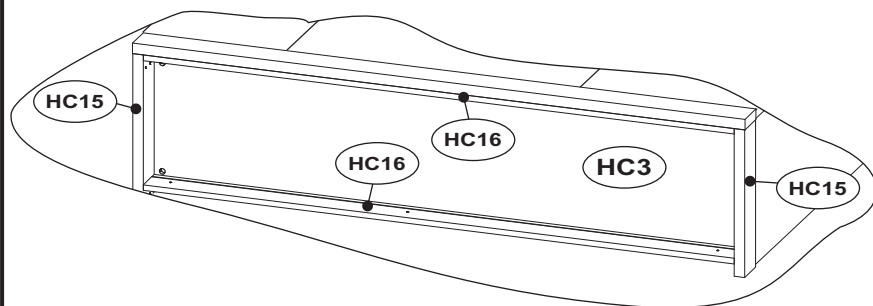
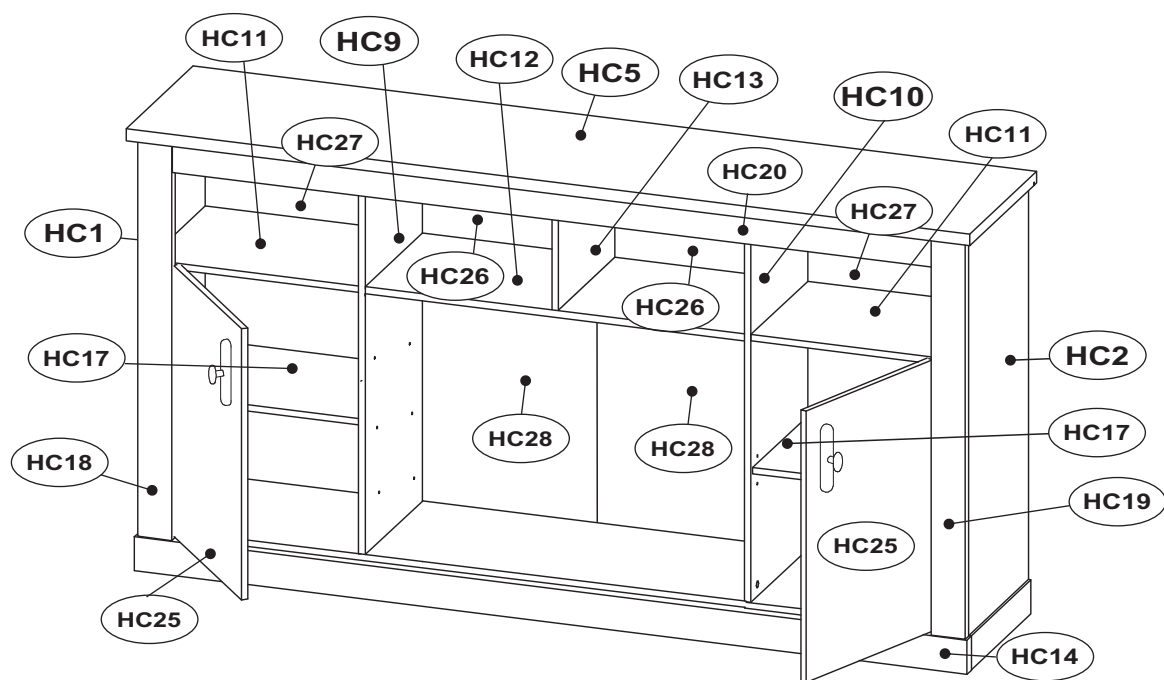

AI No.	Qty	H	W	D	PKG
HC1	x1	932	389	15	1/2
HC2	x1	932	389	15	1/2
HC3	x1	1909	369	15	2/2
HC5	x1	1979	431	28	1/2
HC9	x1	917	368	15	1/2
HC10	x1	917	368	15	1/2
HC11	x2	494	367	15	2/2
HC12	x1	890	367	15	2/2
HC13	x1	289	366	15	1/2
HC14	x1	1954	80	28	2/2
HC15	x2	386	80	28	2/2
HC16	x2	1896	80	15	2/2
HC17	x2	493	360	15	2/2
HC18	x1	932	80	22	2/2
HC19	x1	932	80	22	2/2
HC20	x1	1781	70	18	2/2
HC21	x3	899	210	15	1/2

AI No.	Qty	H	W	D	PKG
HC22	x6	332	140	15	1/2
HC23	x3	871	126	15	2/2
HC24	x3	852	354	2,5	1/2
HC25	x2	636	435	15	2/2
HC26	x2	302	451	2,5	2/2
HC27	x2	937	507	2,5	2/2
HC28	x2	634	451	2,5	2/2
HC29	x3	347	90	15	2/2

# CHAMBORD 55

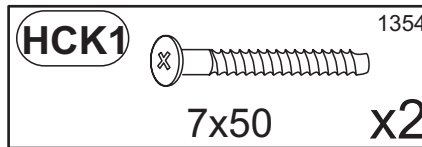
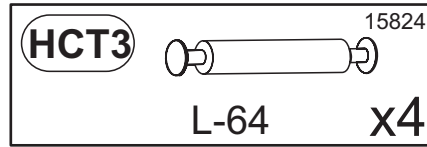
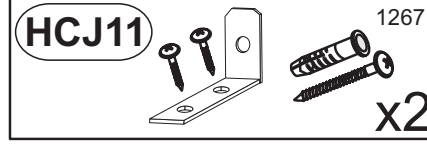
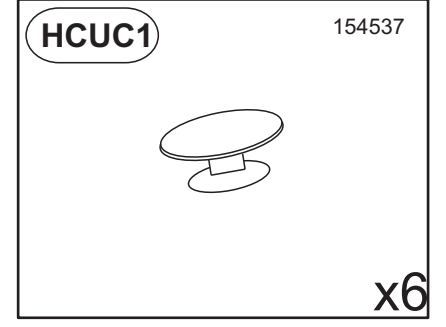
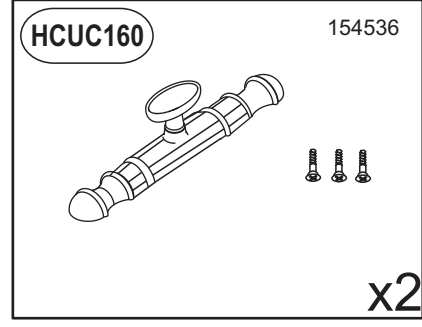
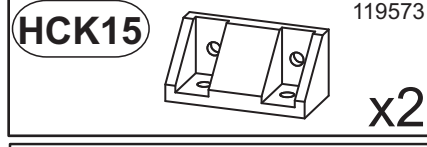
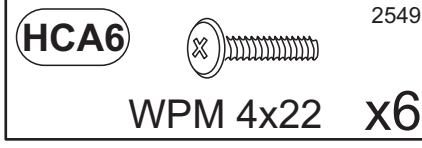
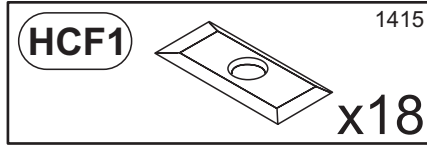
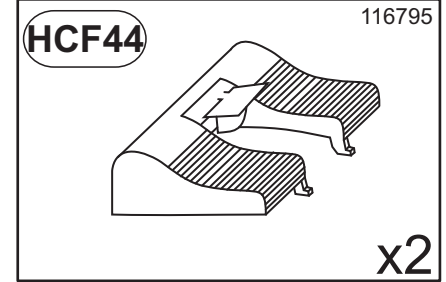
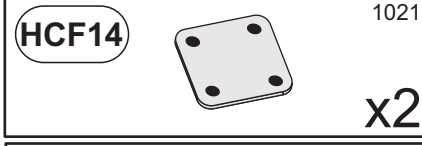
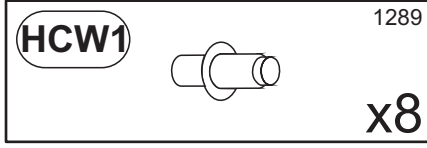
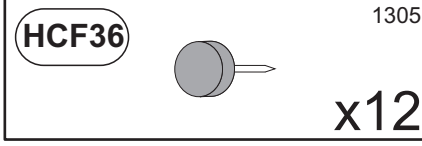
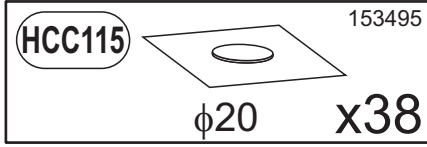
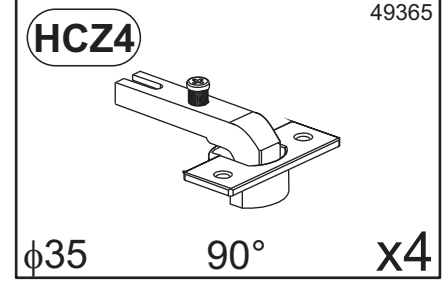
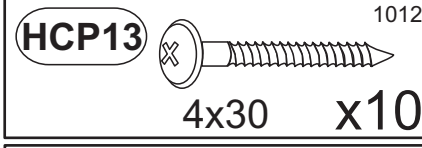
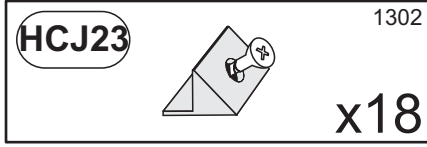
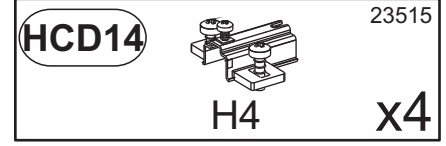
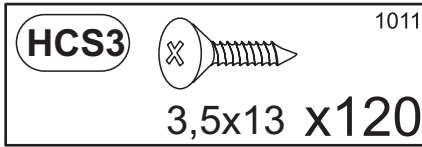
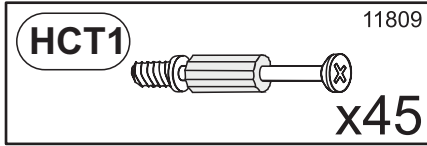
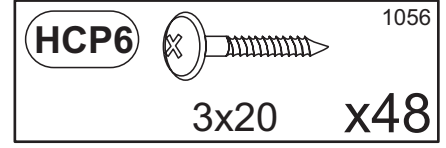
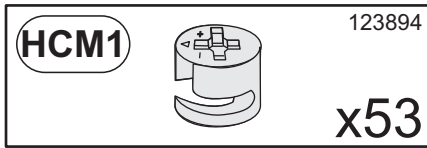
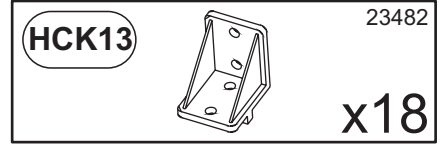
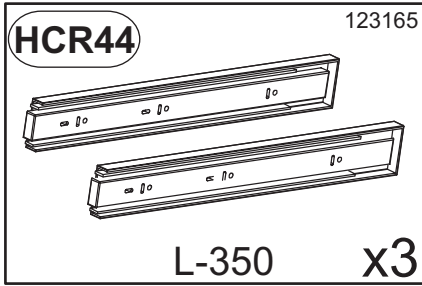
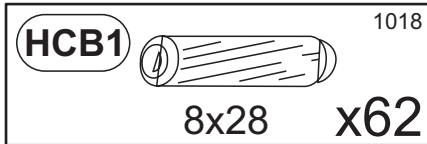

1

HCB1		1018
	8x28	x24
HCM1		123894
		x12
HCR44		123165
	L-350	x3
HCS3		1011
	3,5x13	x12

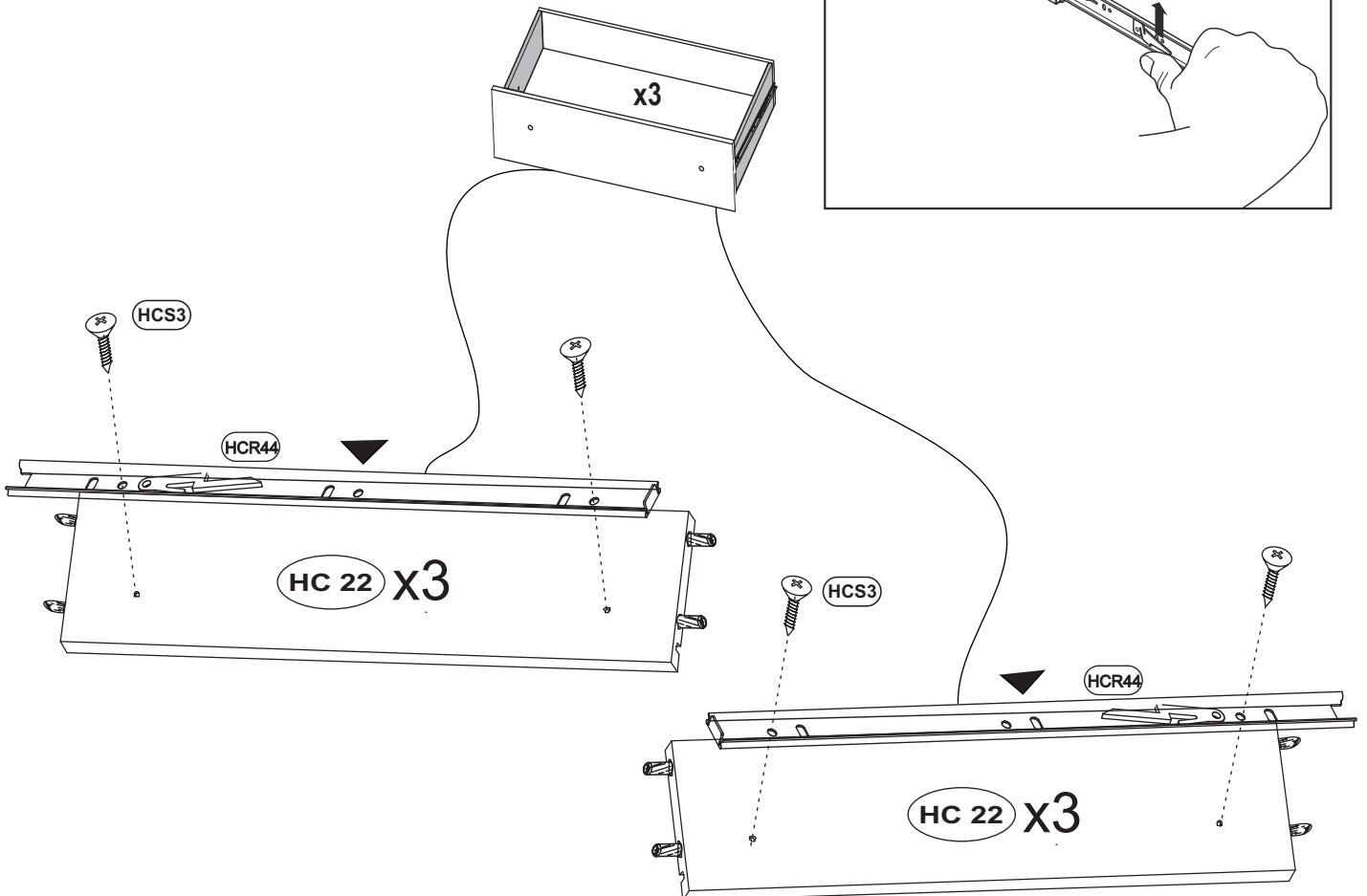
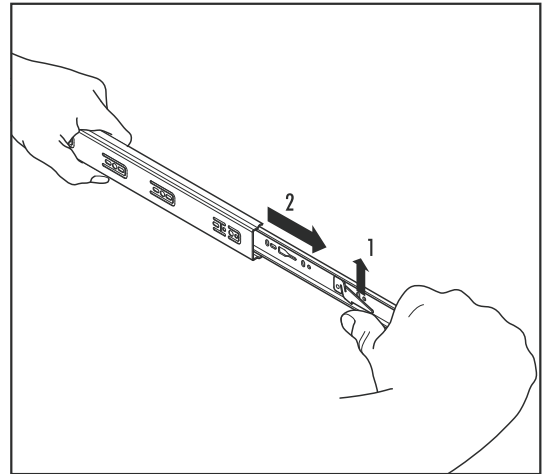
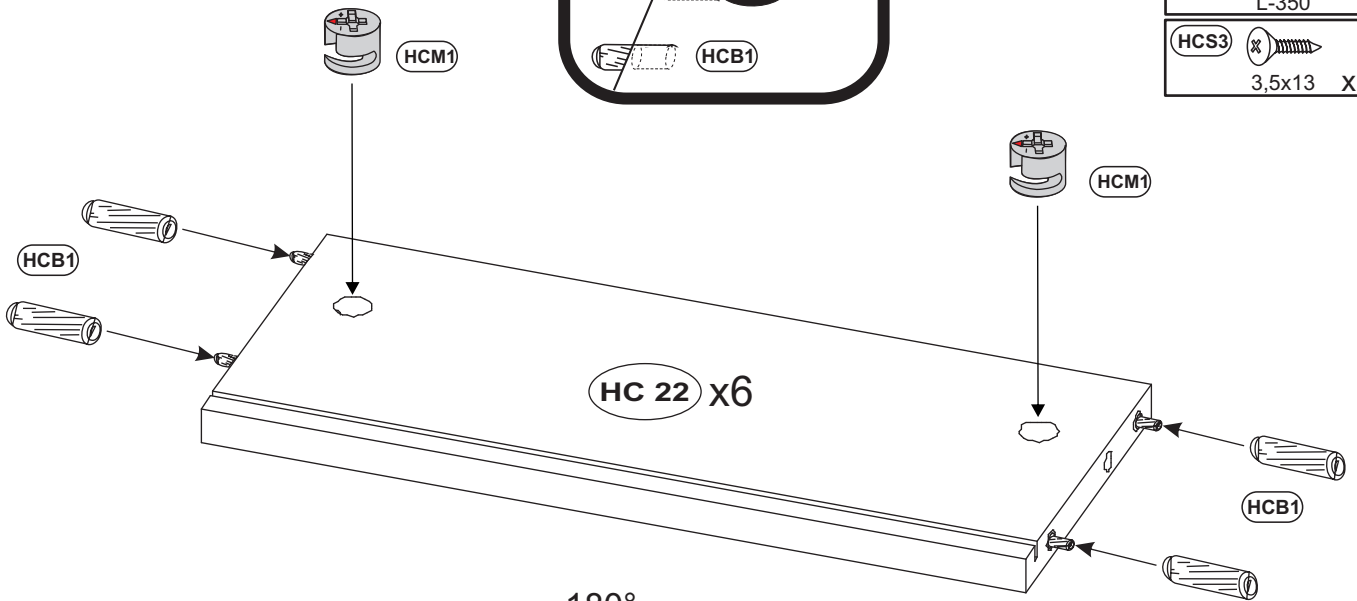
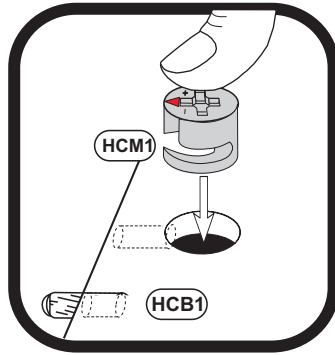

2

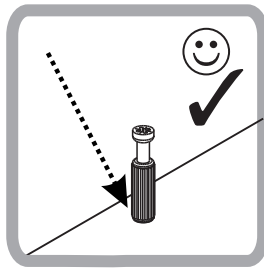
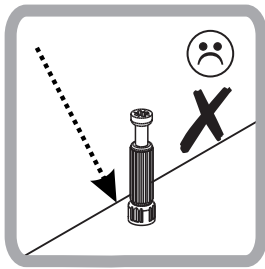

HCT1		11809
		x15
HCB1		1018
	8x28	x6
HCM1		123894
		x3

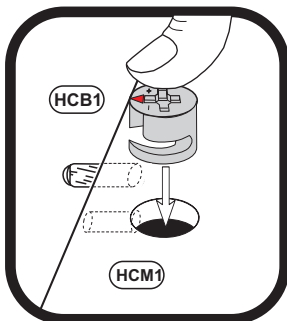
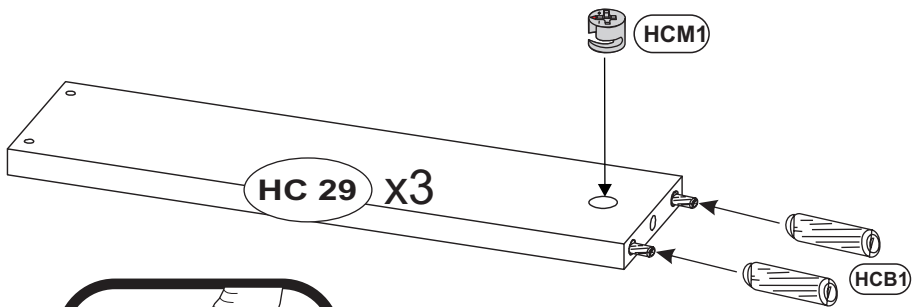
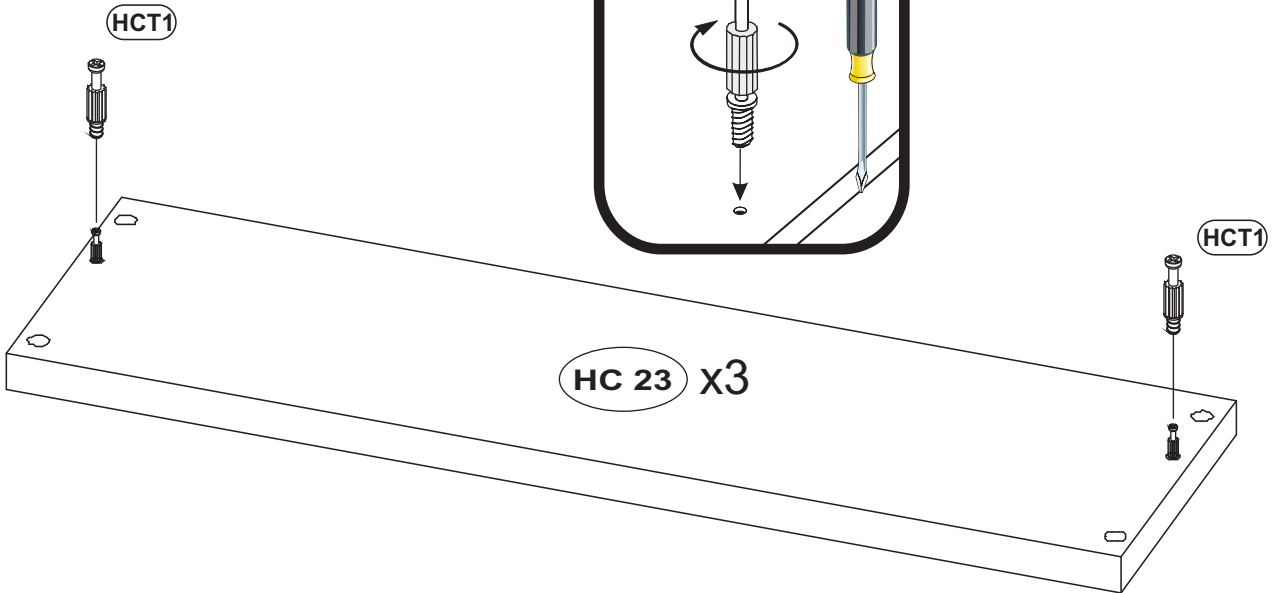
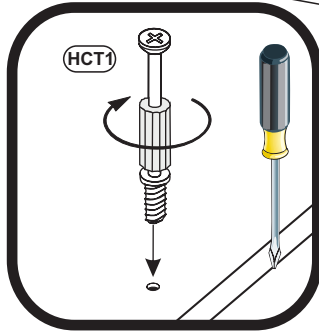
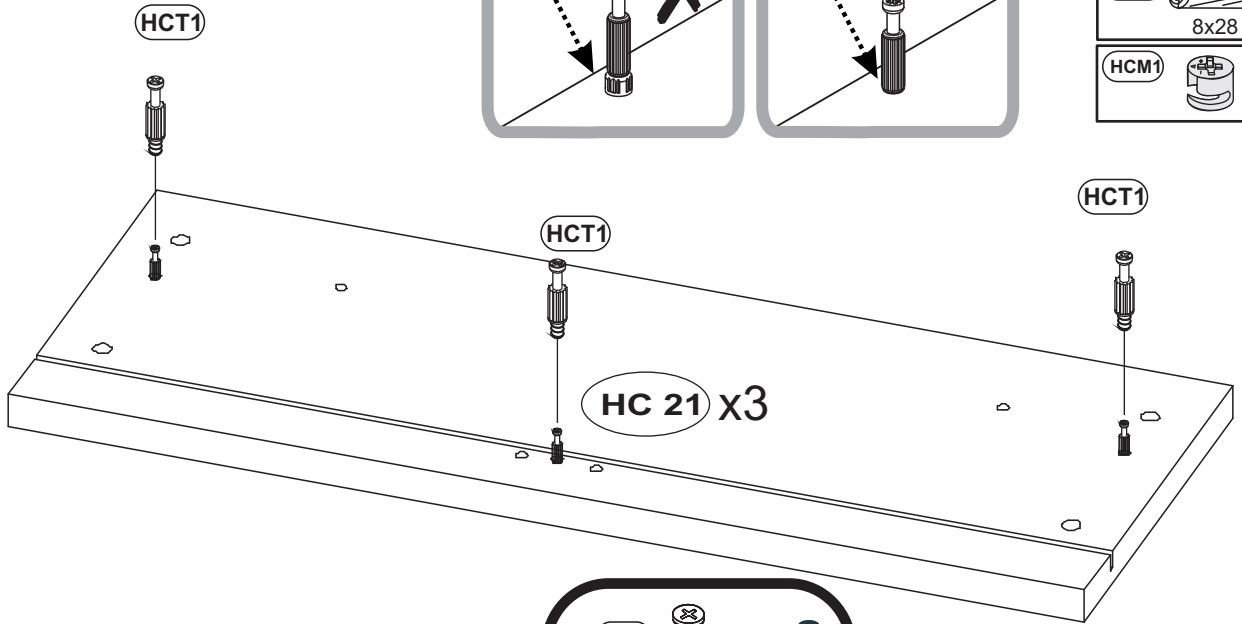

3

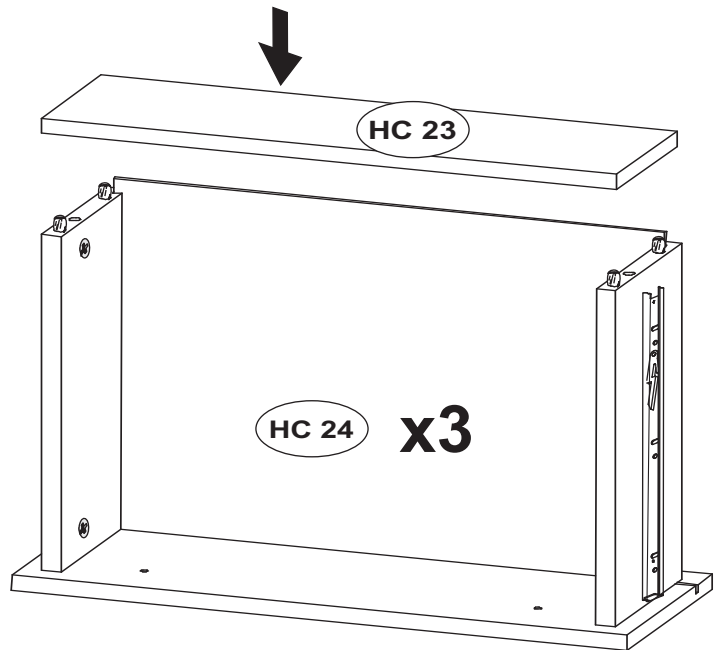
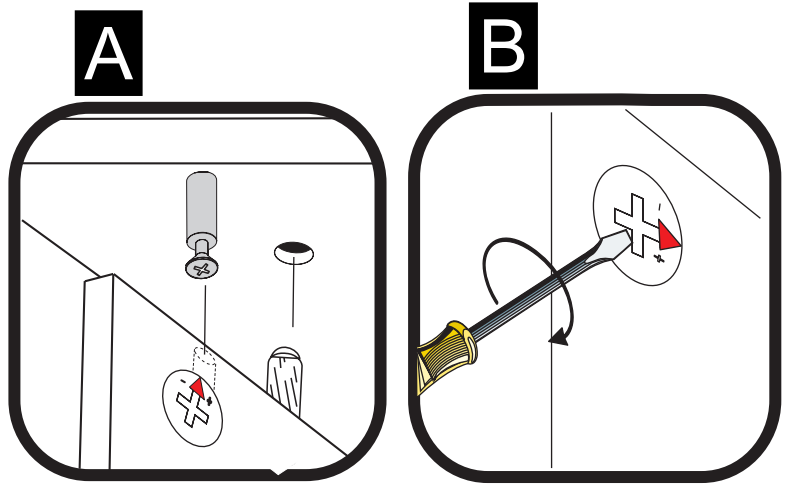
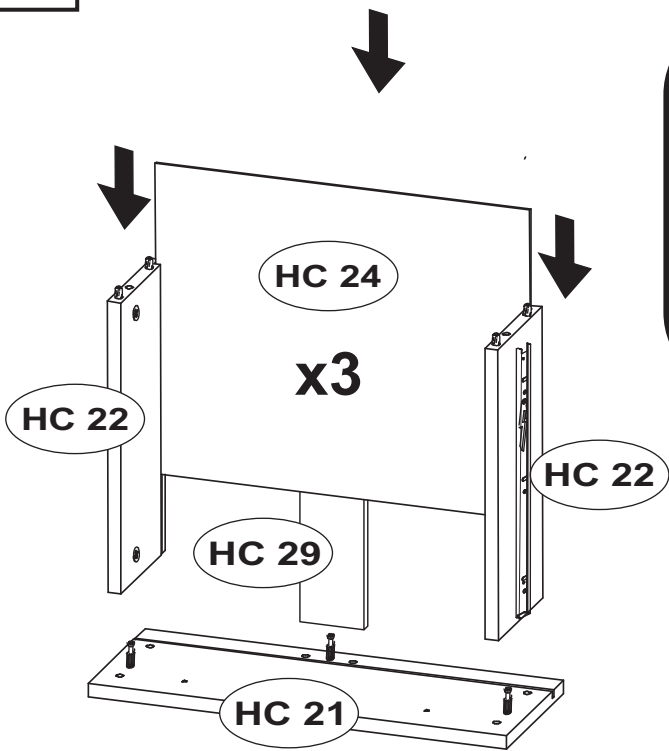

4

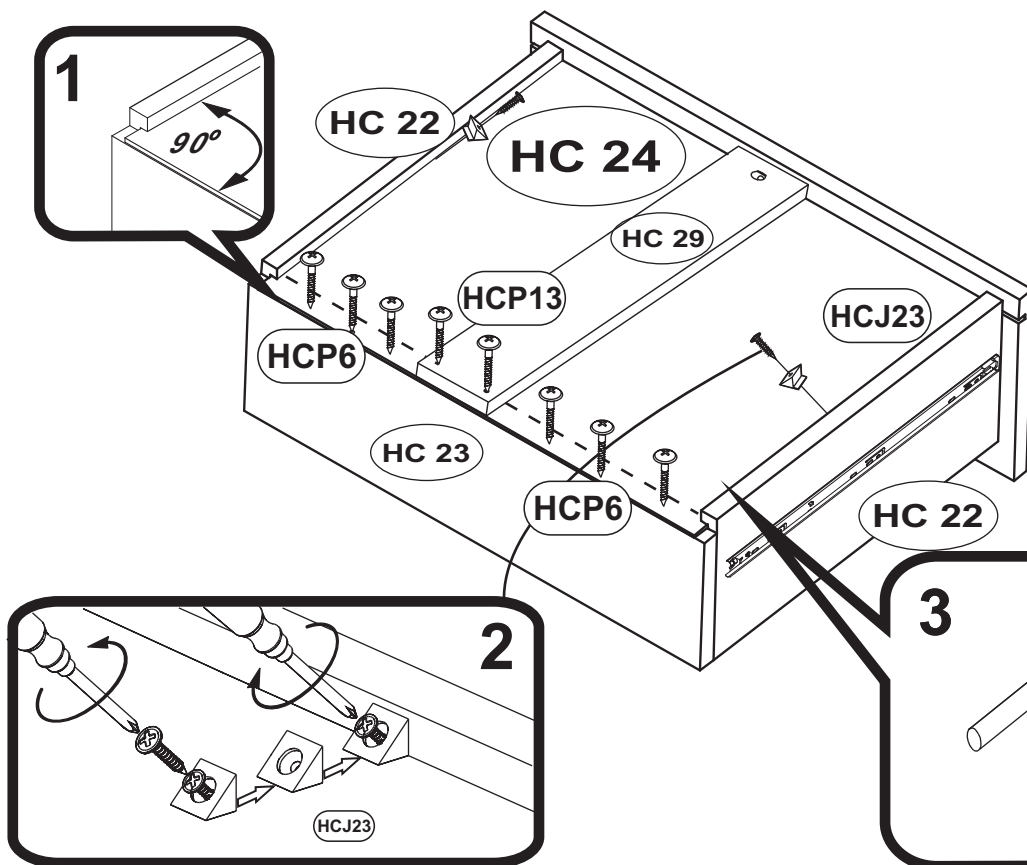

HCJ23		1302	x6
HCP6		1056	x18
HCP13		1012	x6

x3

5

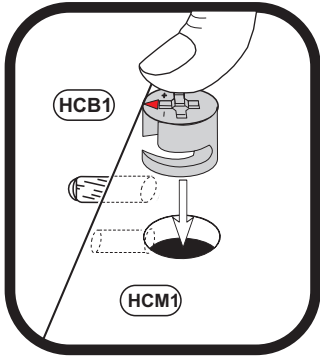

HCB1		1018
	8x28	x4
HCM1		123894
		x4
HCT1		11809
		x8

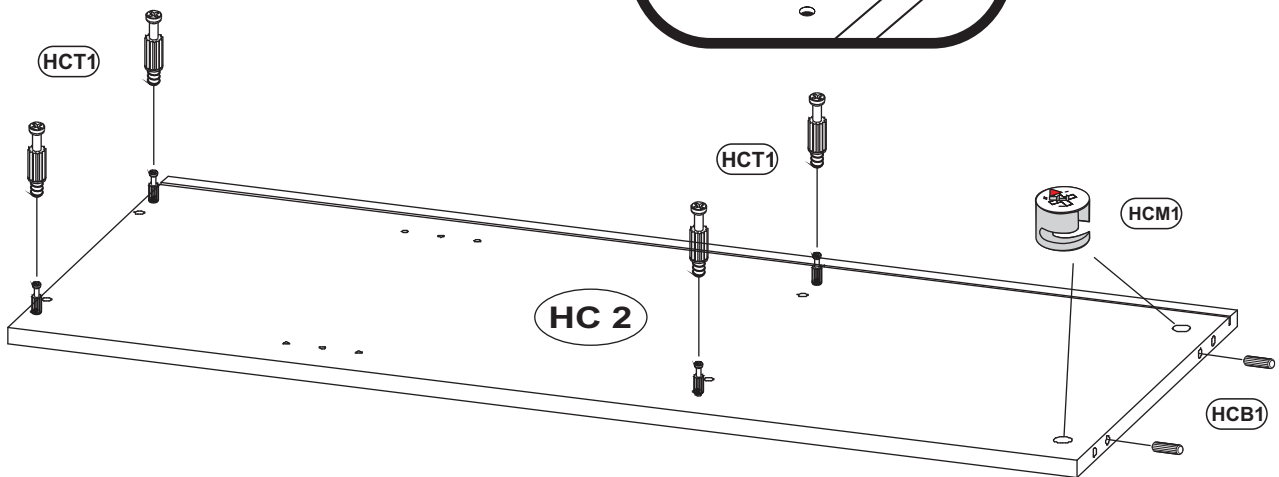
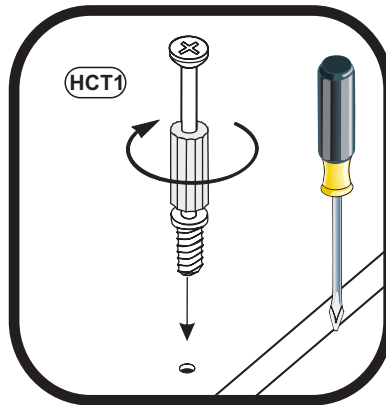
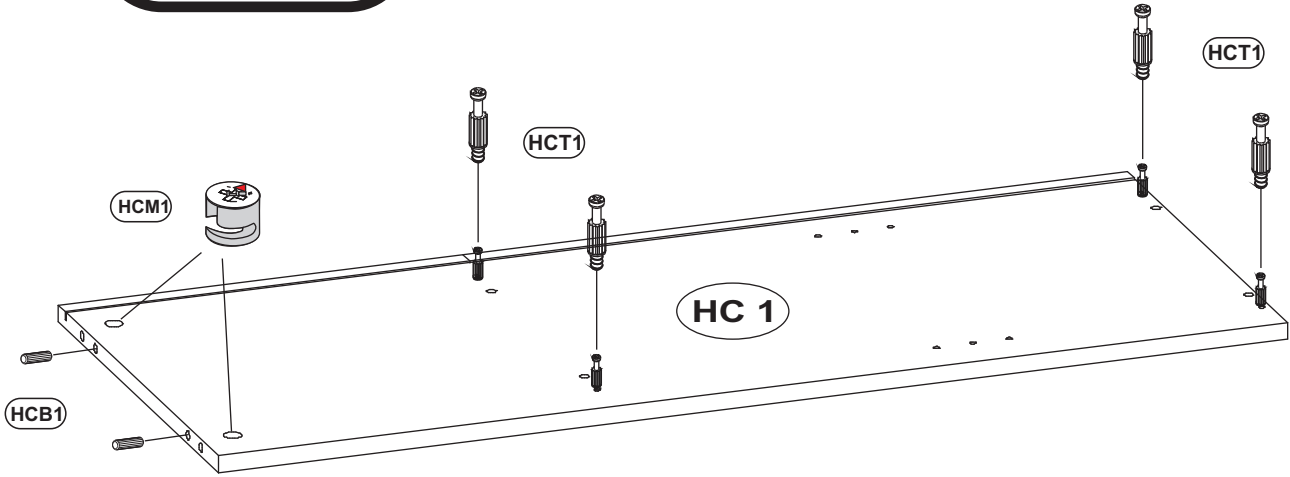

HCS3 1011  
3,5x13 x12

HCM1 123894  
x8

HCB1 1018  
8x28 x8

HCR44 123165  
L-350 x3

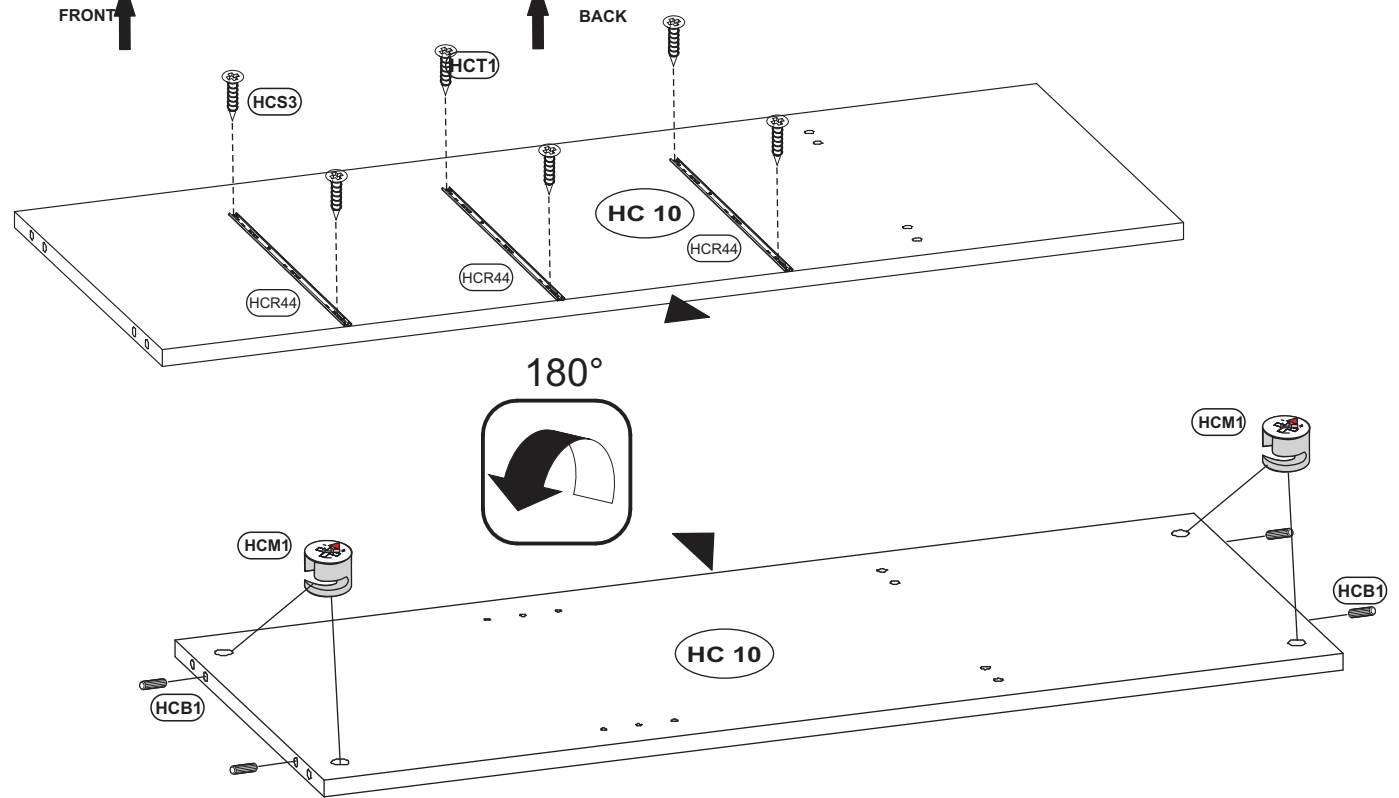
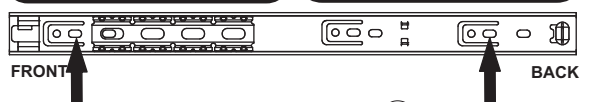
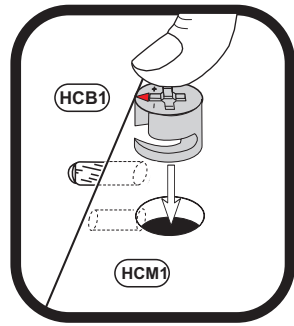
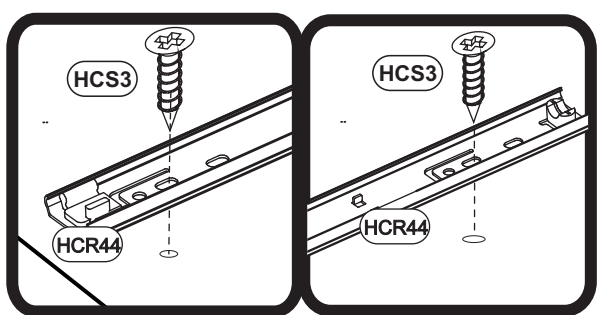
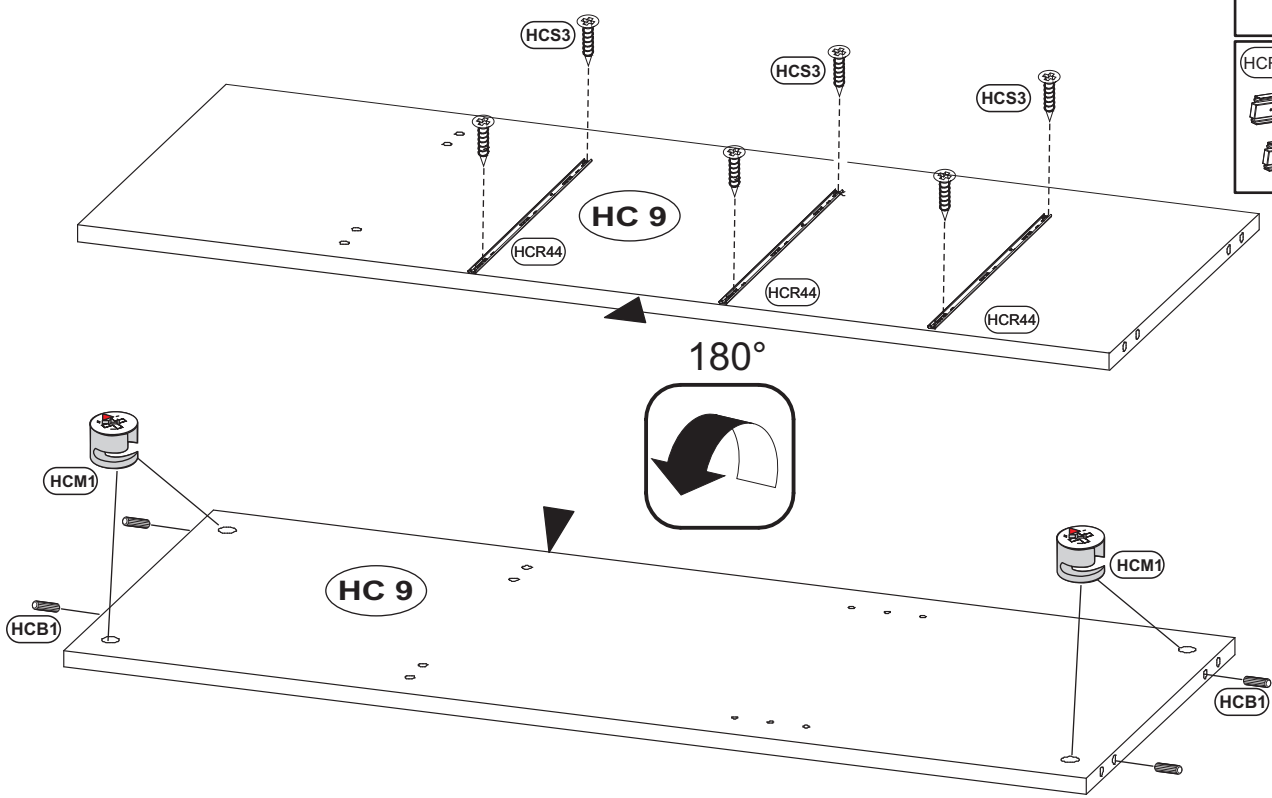



7

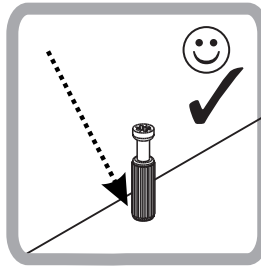
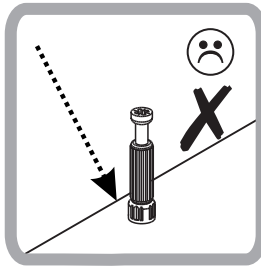

(HCB1)		1018
	8x28	x4
(HCT1)		11809
		x4
(HCM1)		123894
		x4

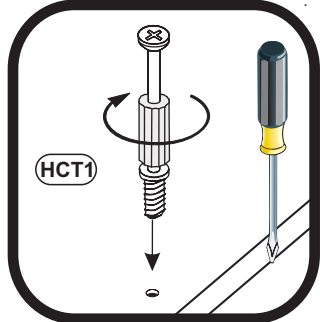
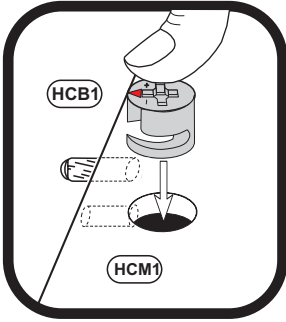
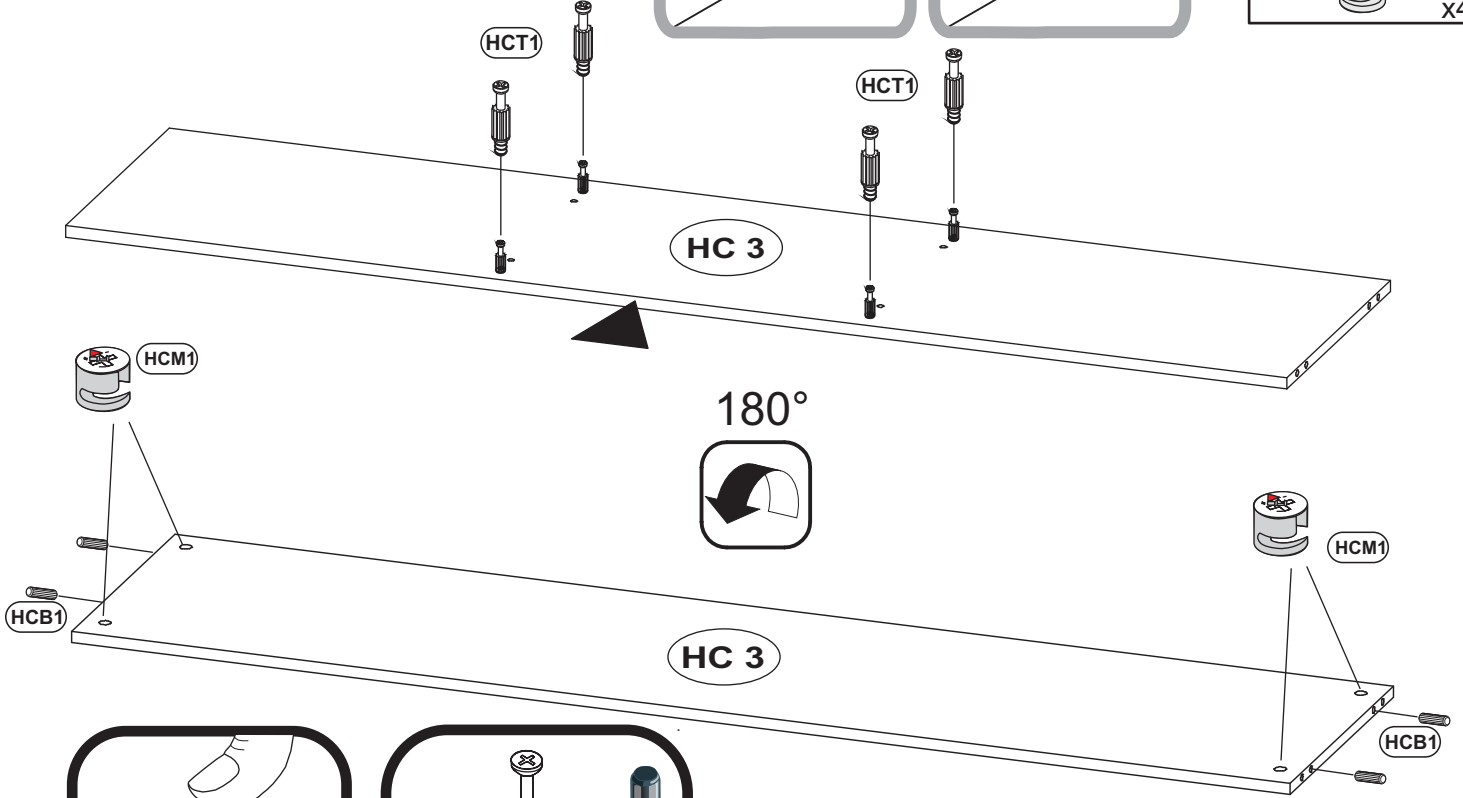

8

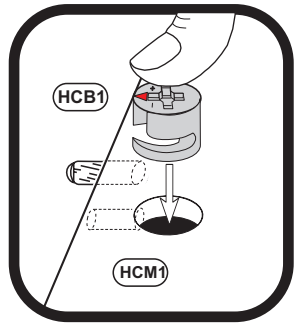

(HCB1)		1018
	8x28	x8
(HCM1)		123894
		x8

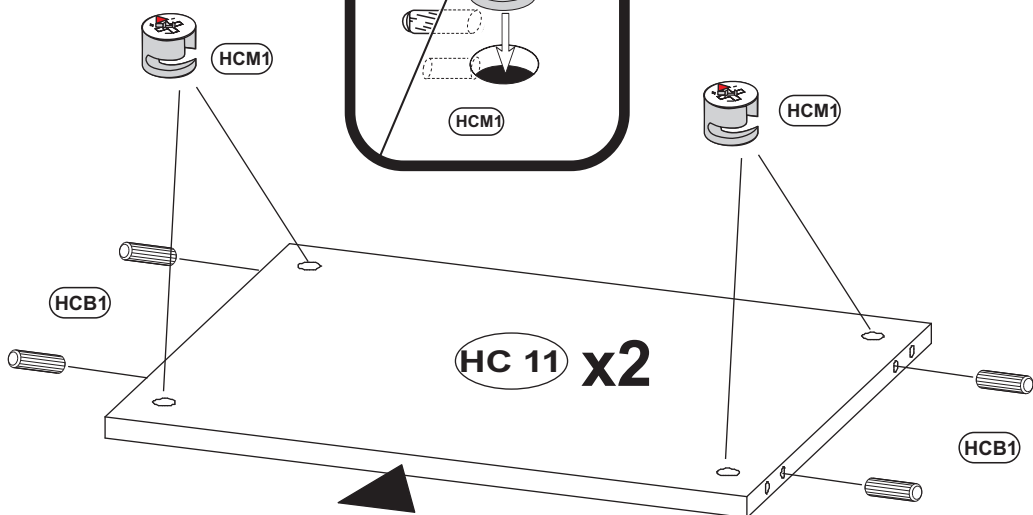

9

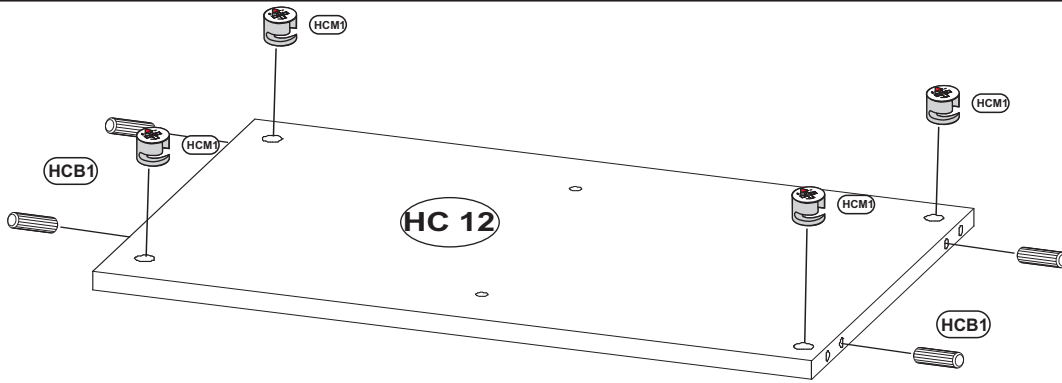

HCB1 1018  
8x28 x4

HCM1 123894  
x4

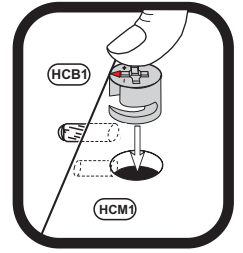

10

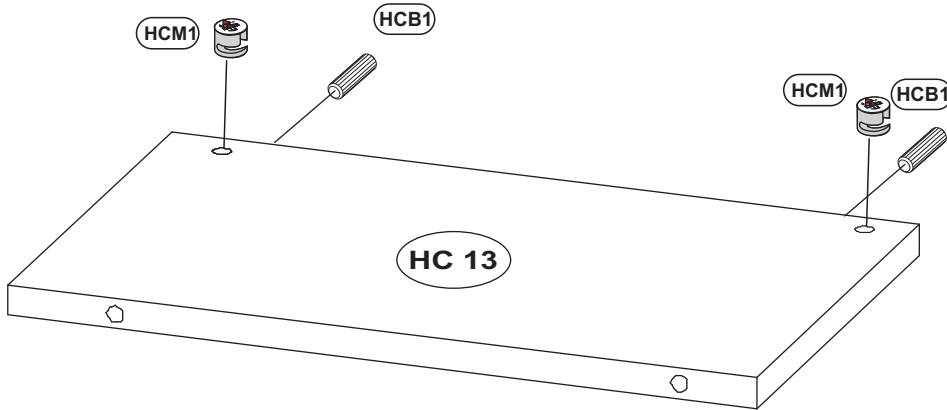

HCB1 1018  
8x28 x2

HCM1 123894  
x2

11

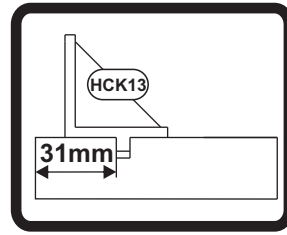
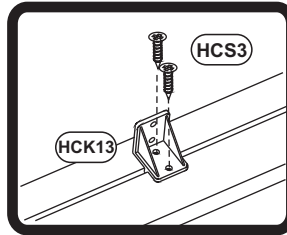

HCK13 23482  
x8

HCS3 1011  
3,5x13 x16

HCD14 23515  
H4 x4

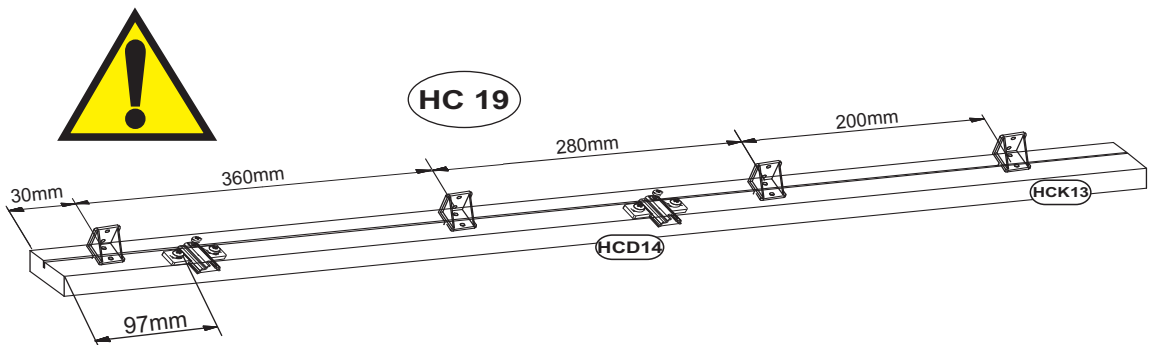
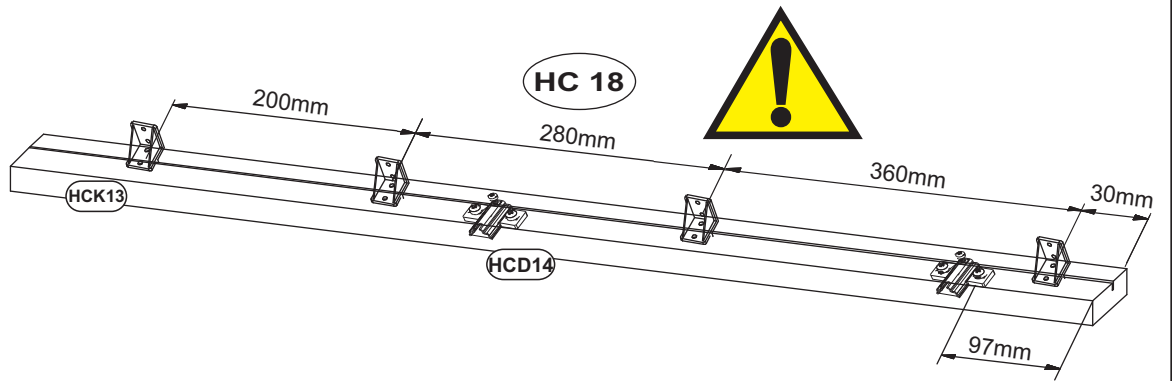
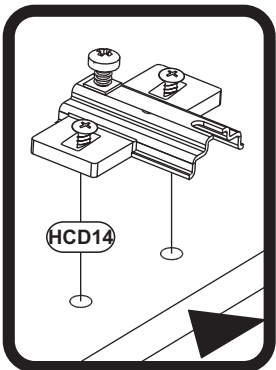

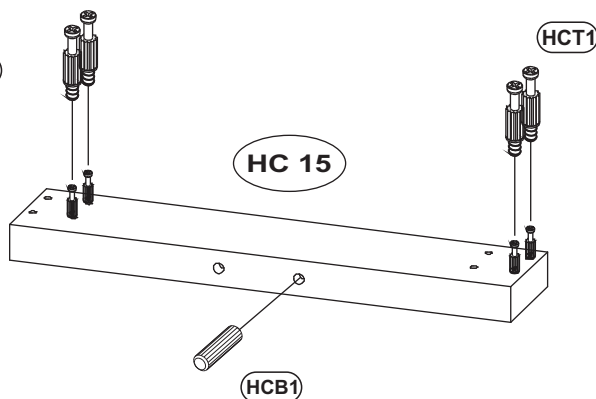
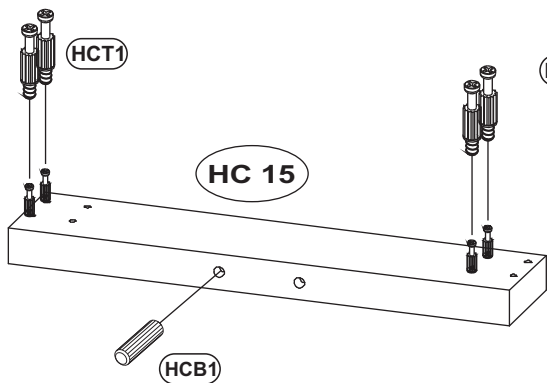
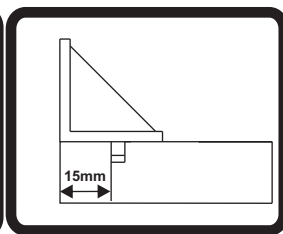
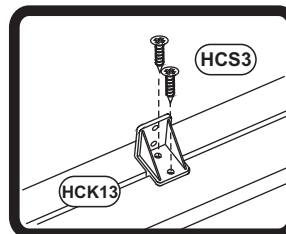
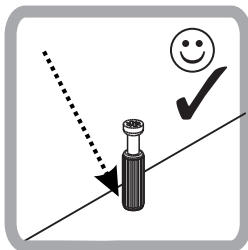
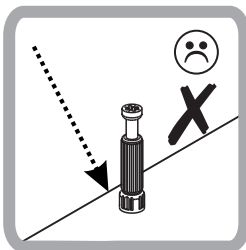
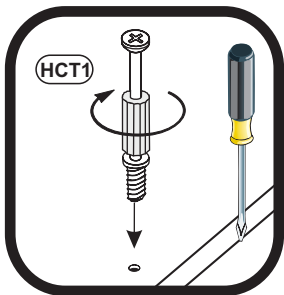
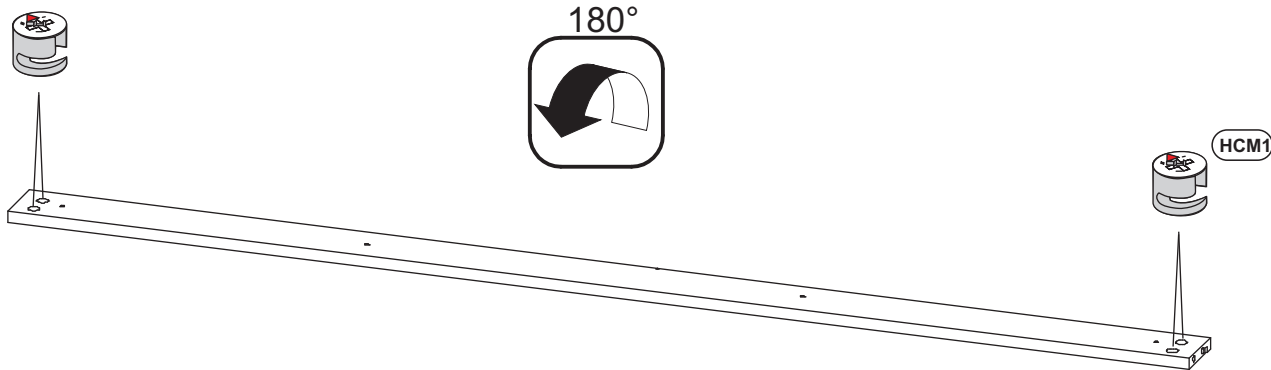
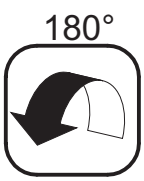
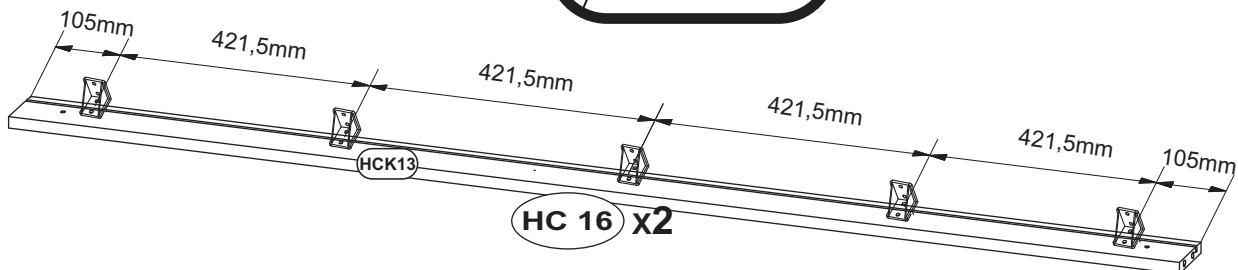
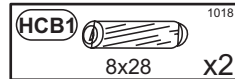
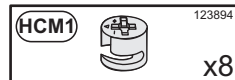
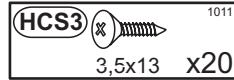
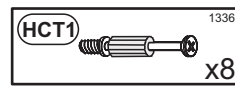
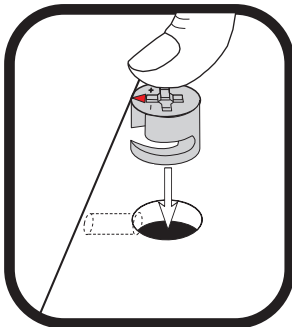

# 13

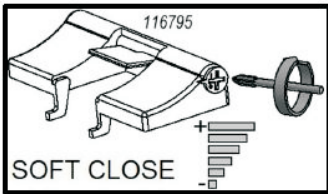
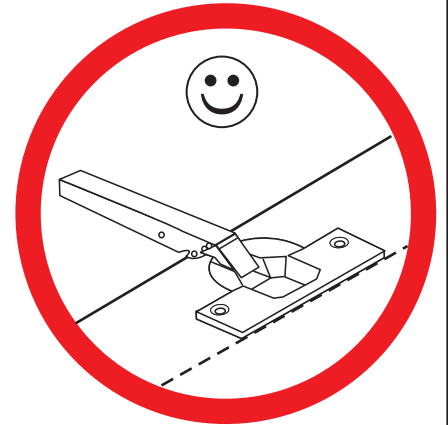
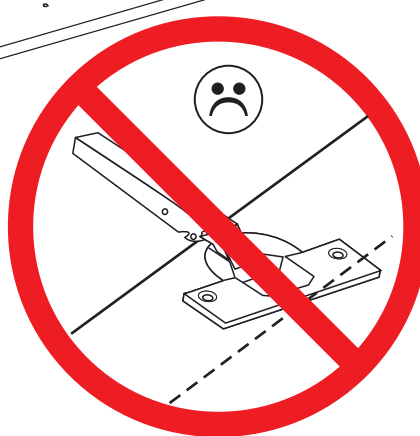
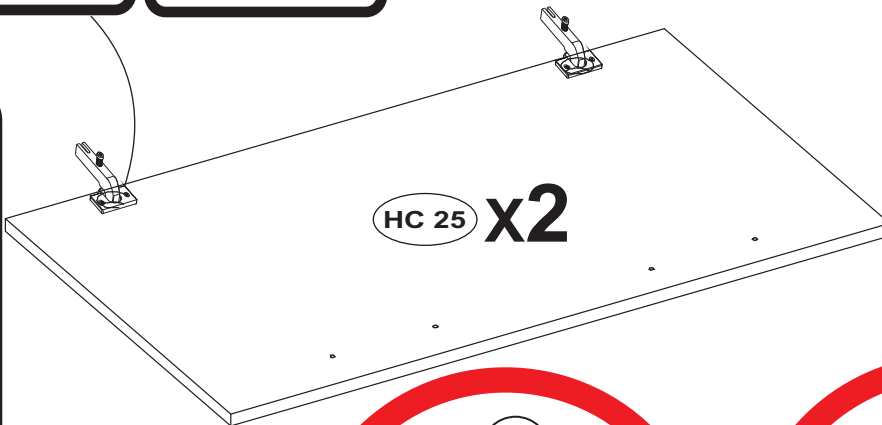
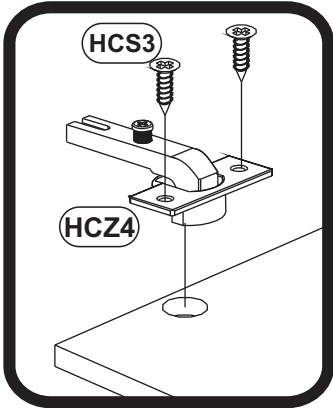
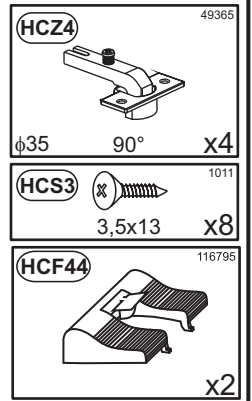
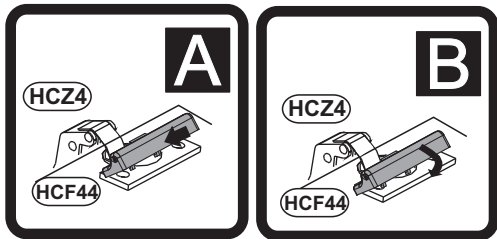

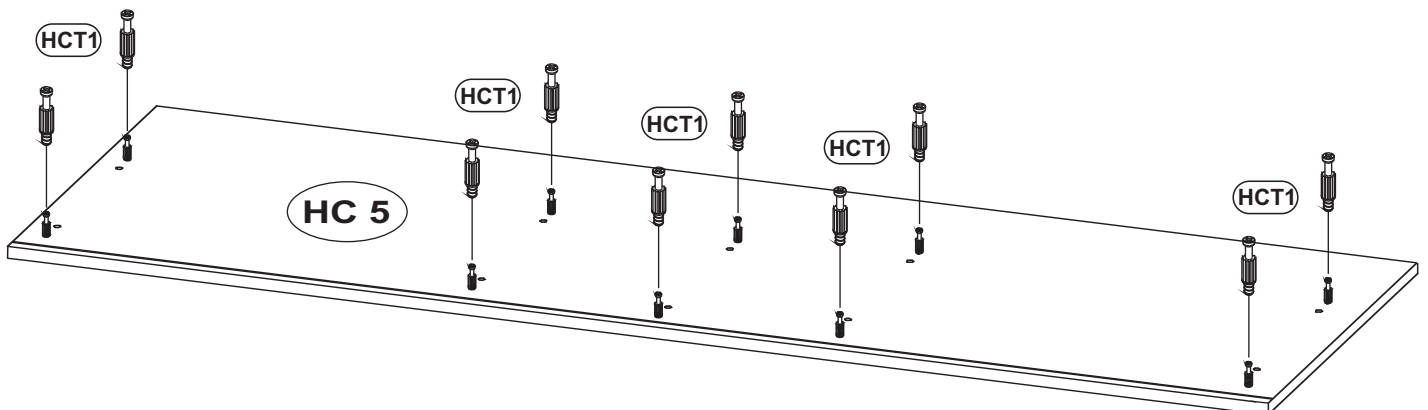
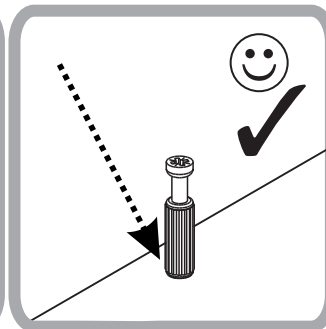
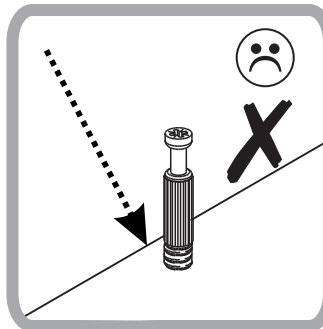
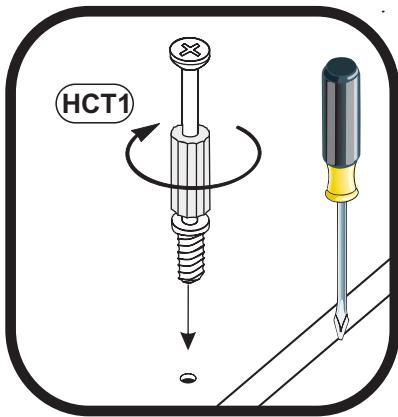
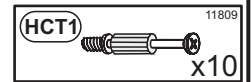

# 14

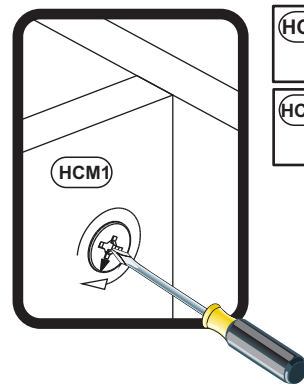
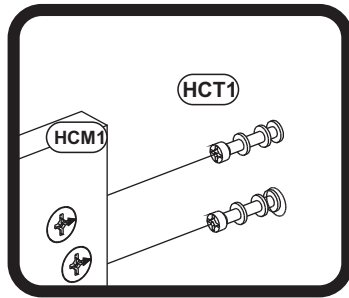

15

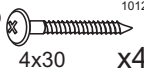

HCP13		1012
	4x30	x4
HCF36		1305
		x12

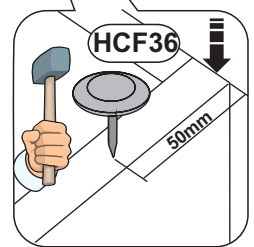
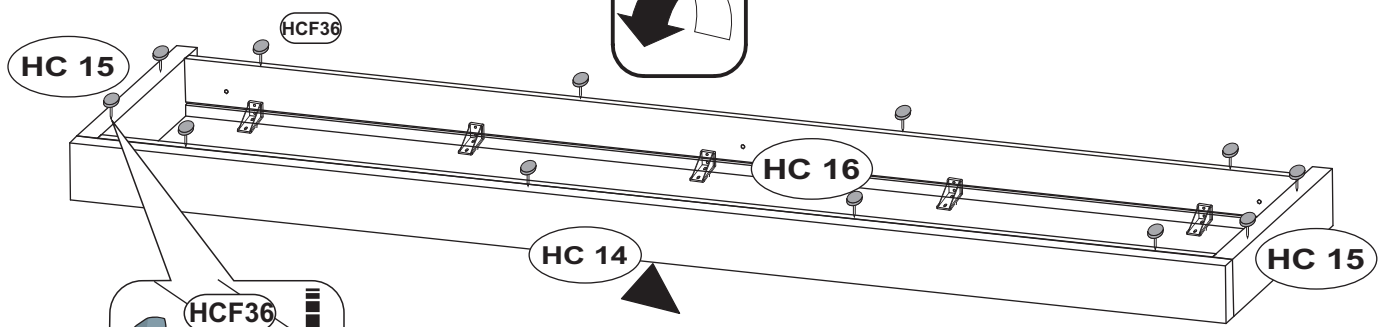
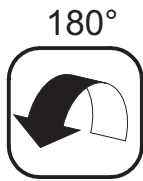
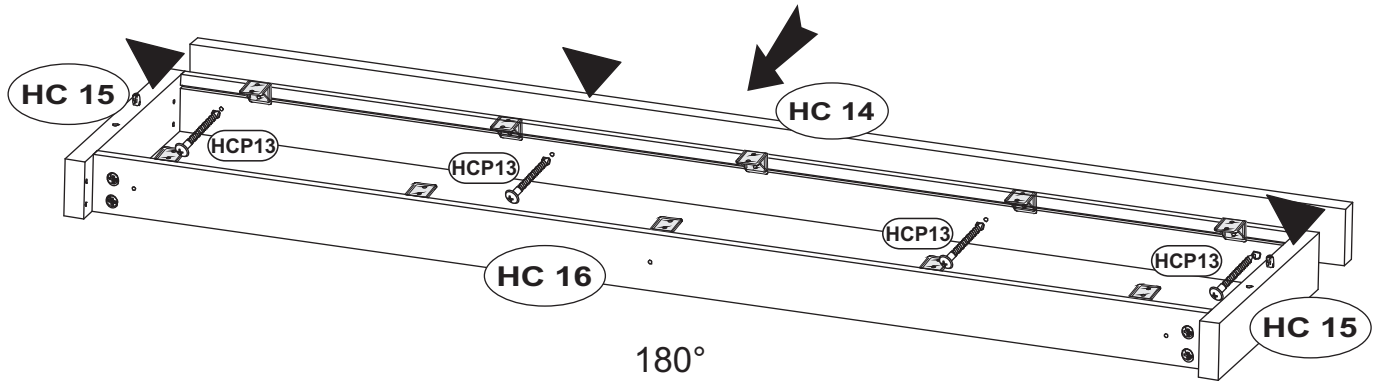
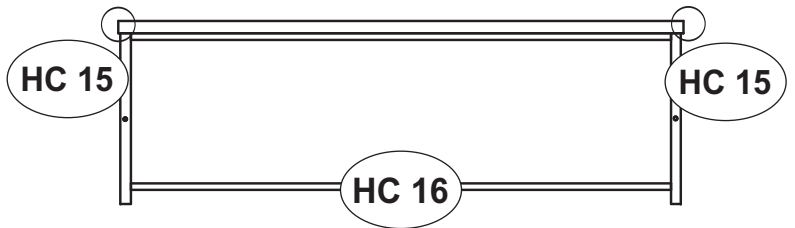
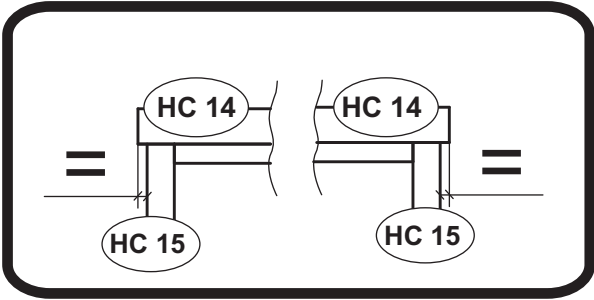
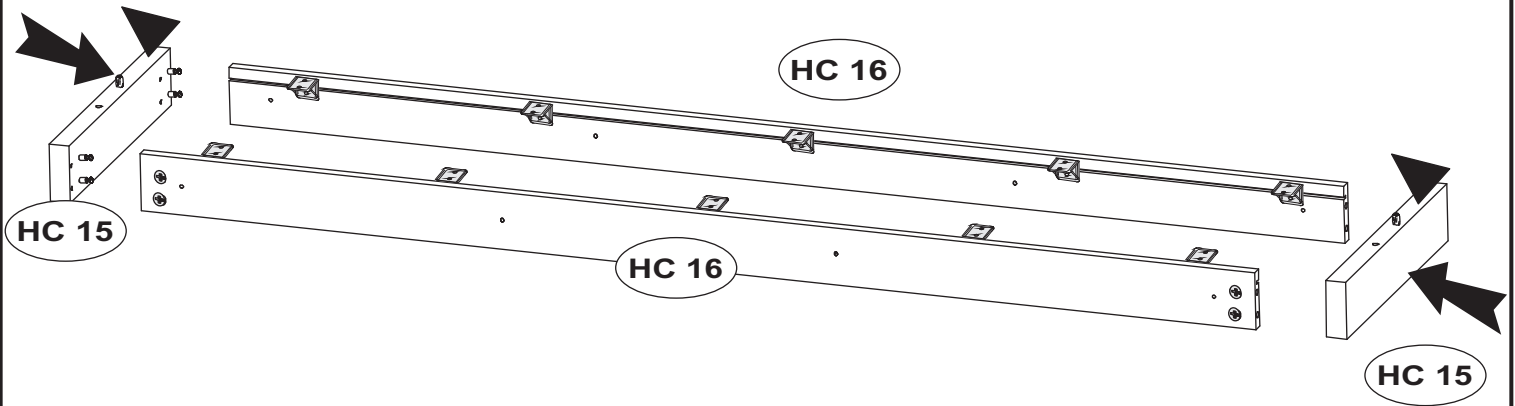

16

HCT3 <sup>15824</sup>  
L-64 x4

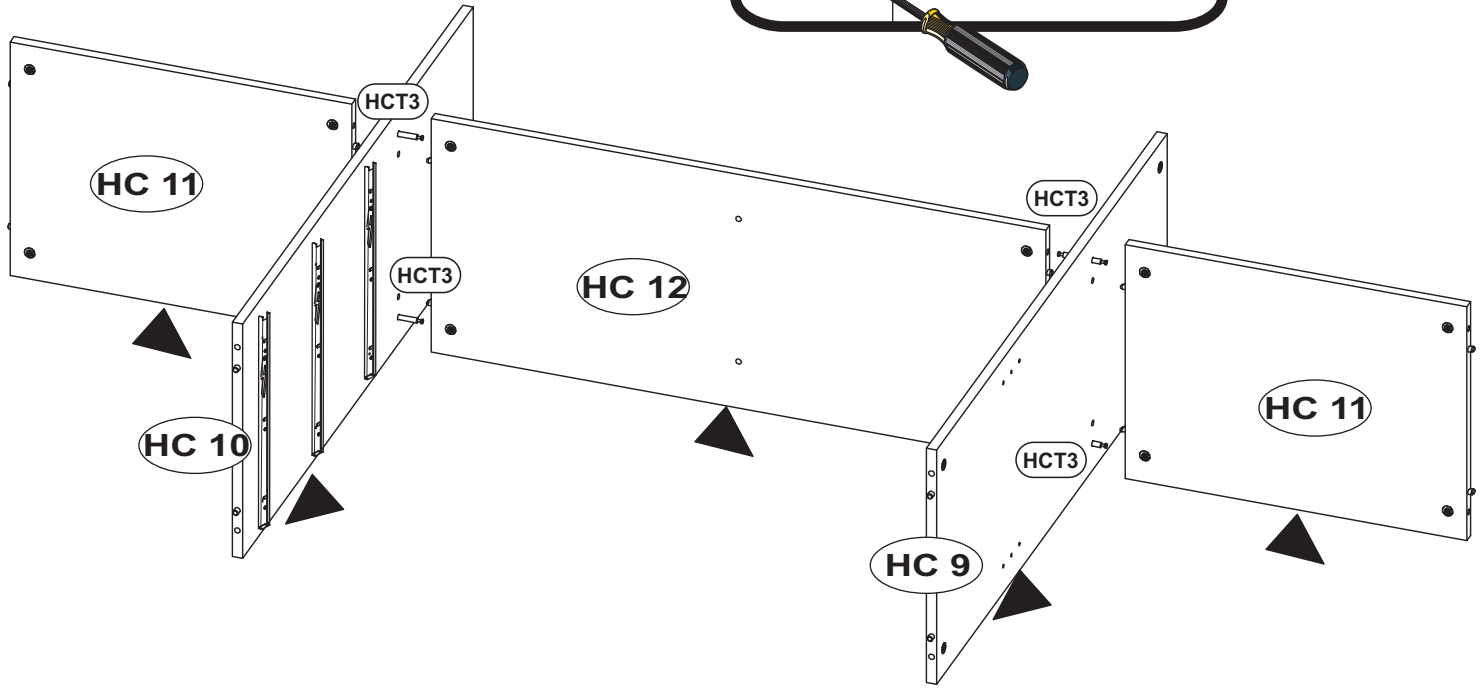
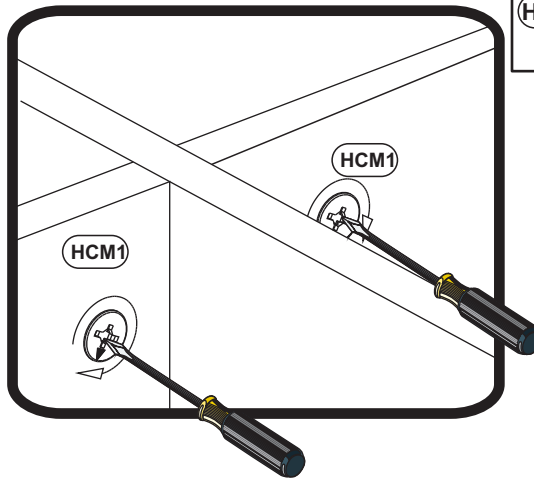
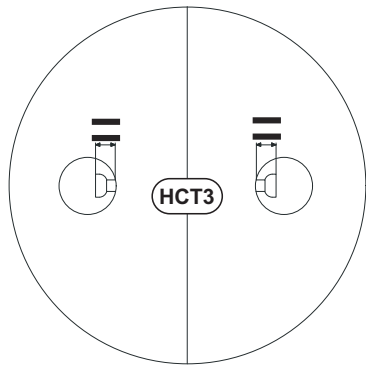

17

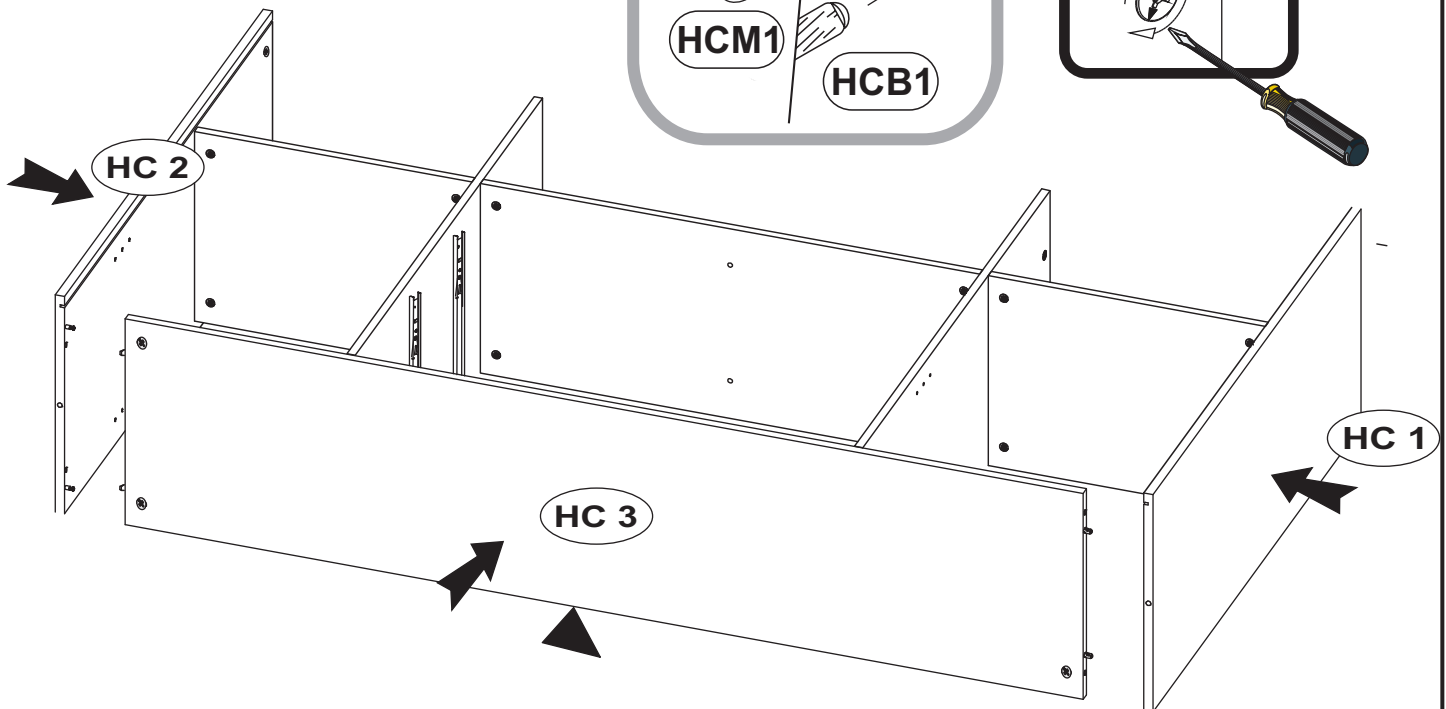
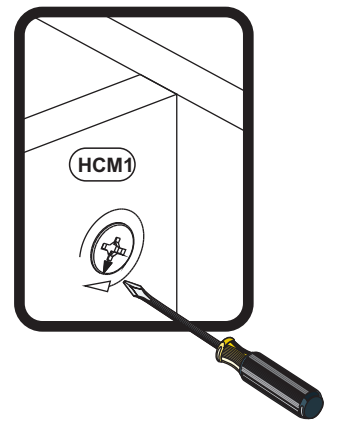
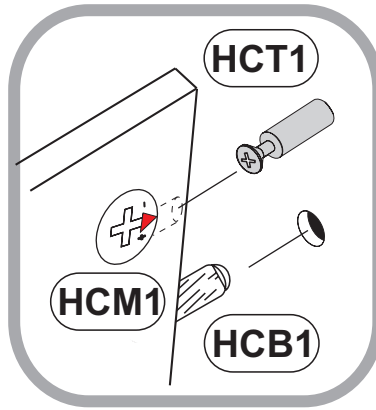

18

HCK1 1354  
7x50 x2

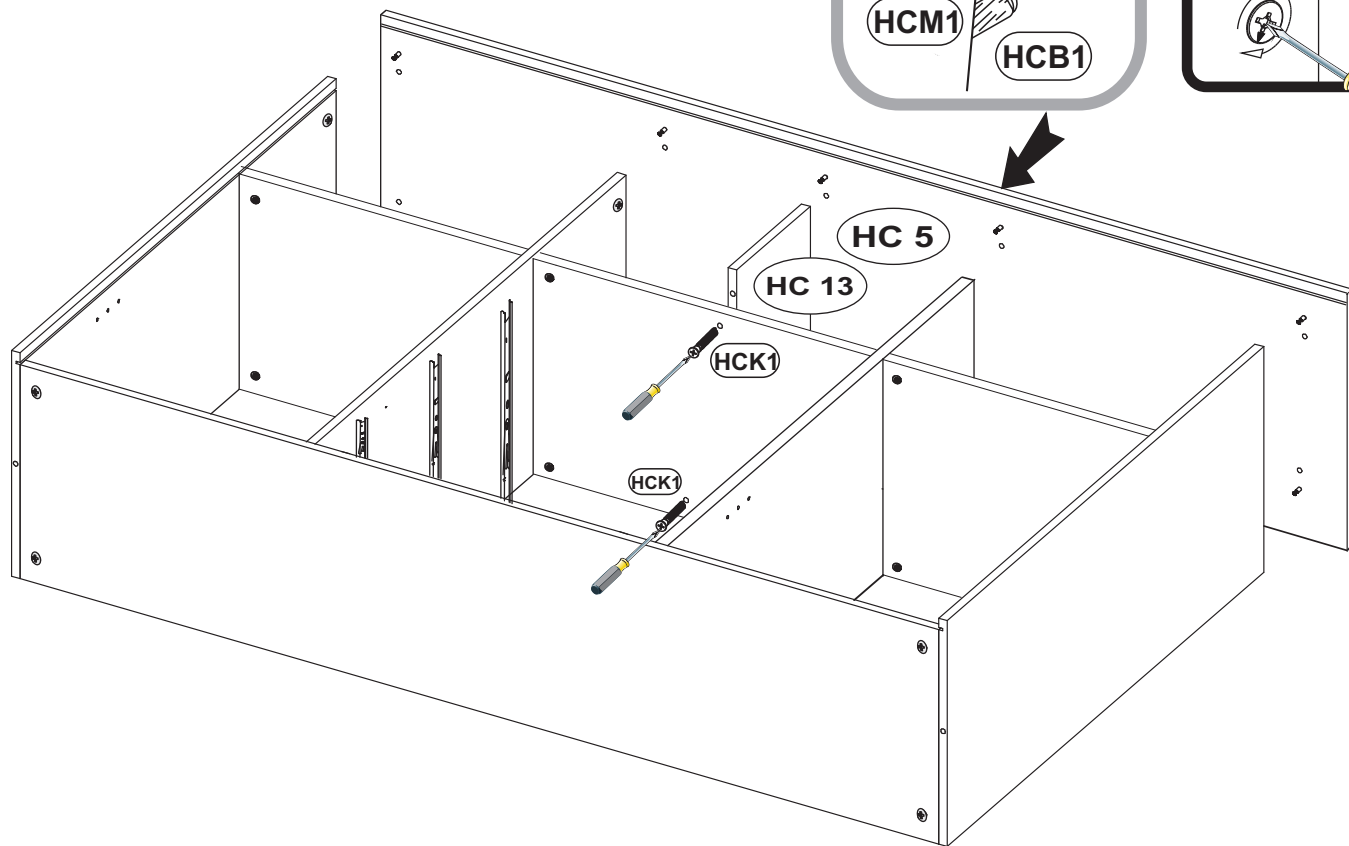
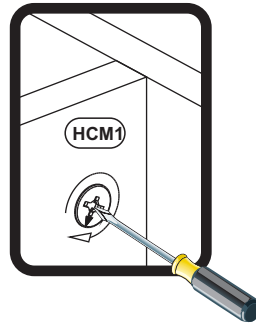
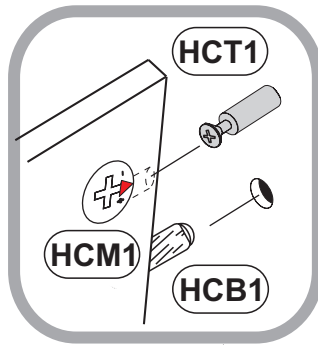

19

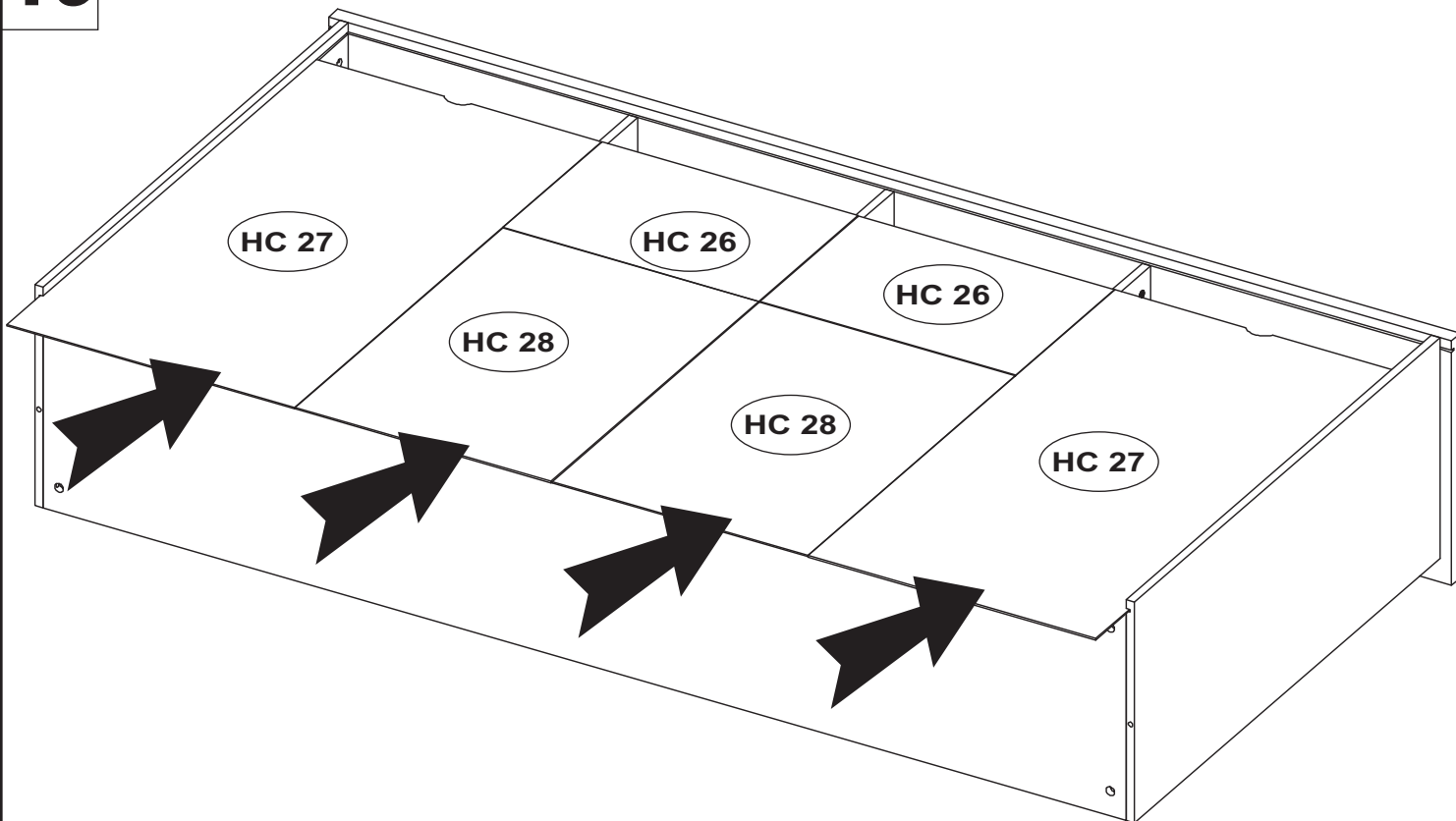

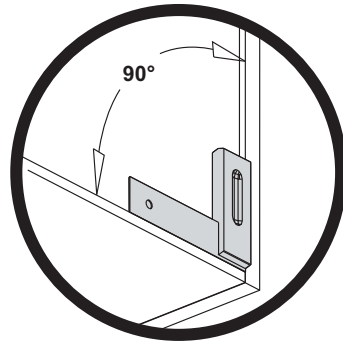
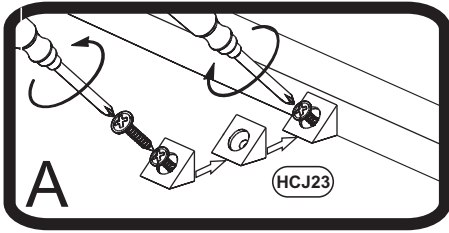

20



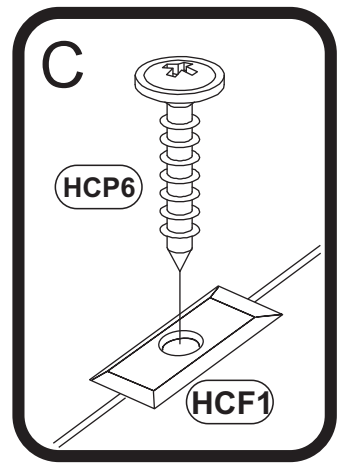
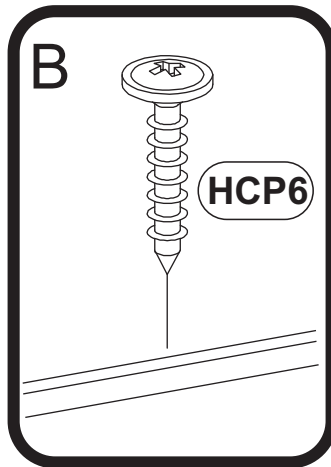
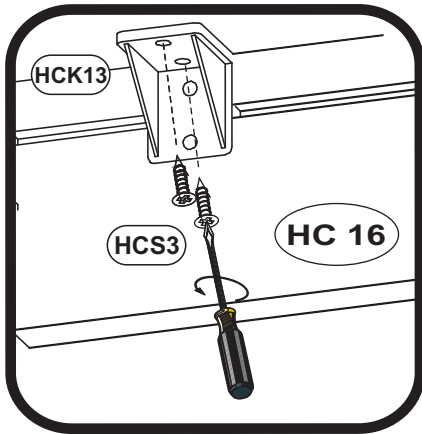
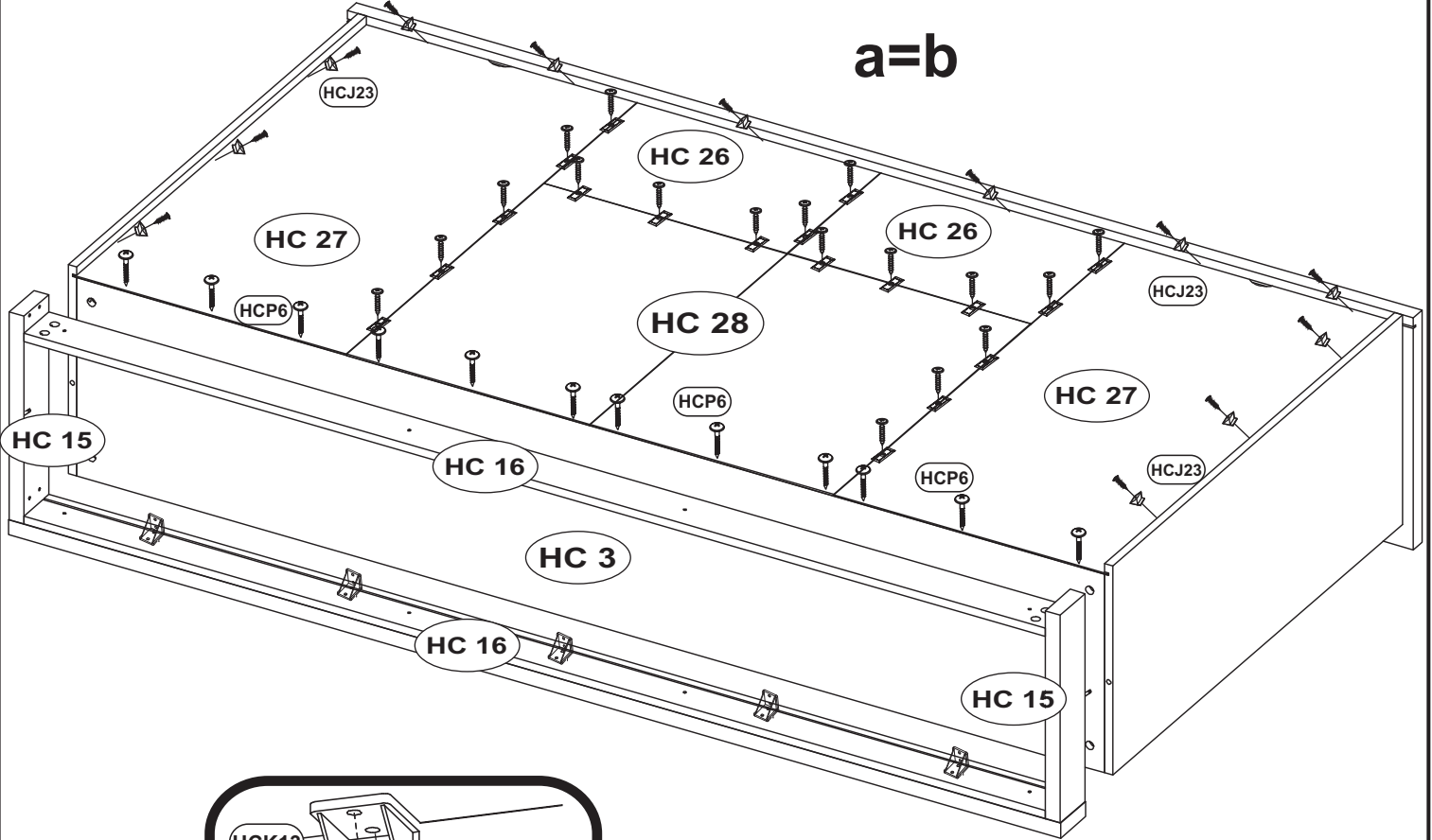

HCJ23		1302
		x12
HCP6		1056
	3x20	x30
HCF1		1415
		x18
HCS3		1011
	3,5x13	x20



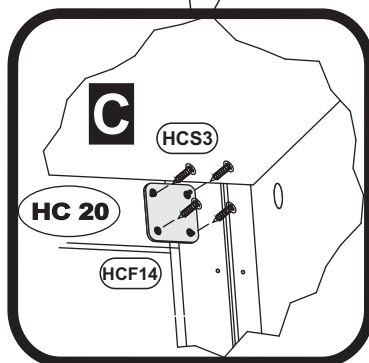
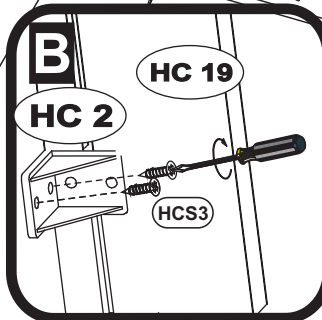
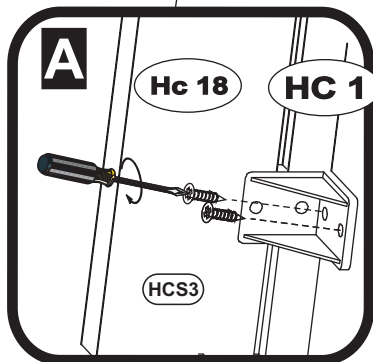
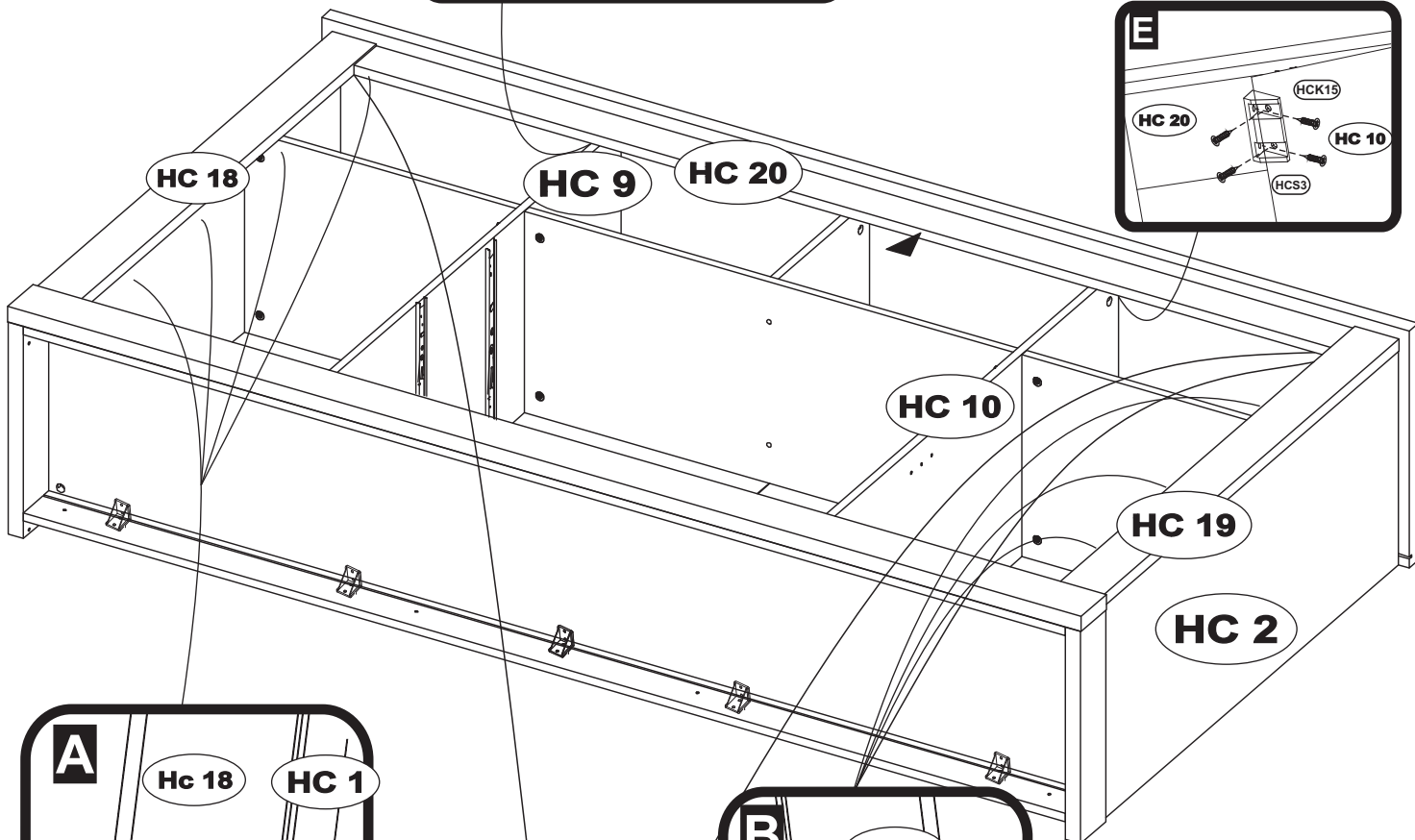
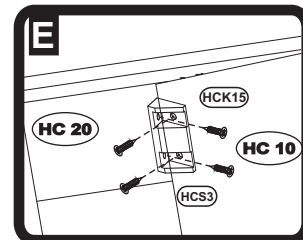
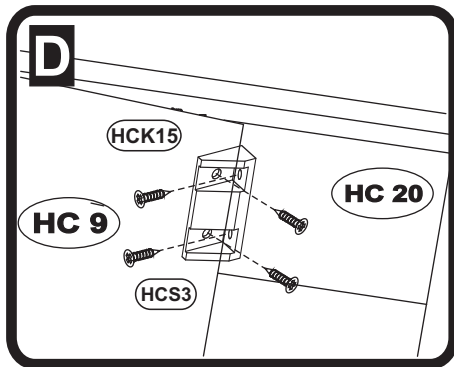

(HCF14)		1021
		x2
(HCS3)		1011
	3,5x13	x32
(HCK15)		119573
		x2



HCJ11		1267
		x2
HCW1		1289
		x8

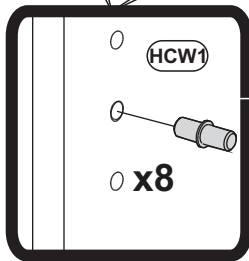
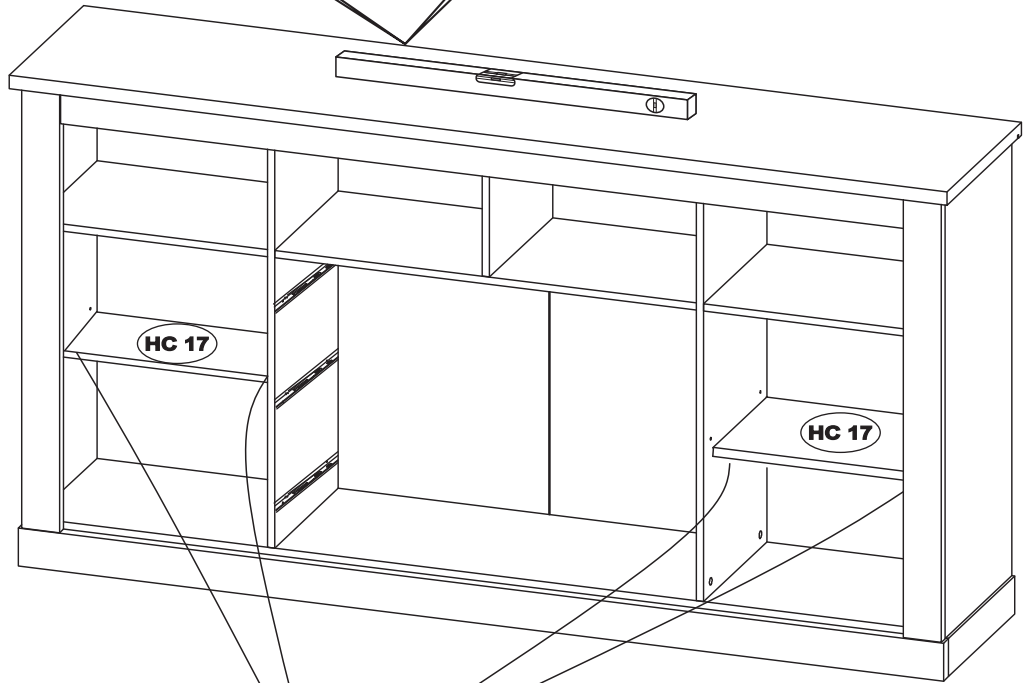
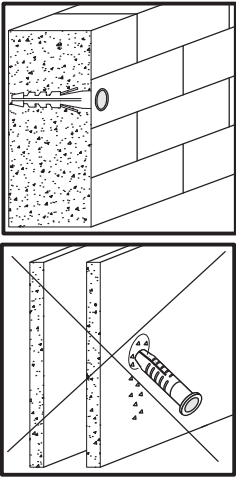
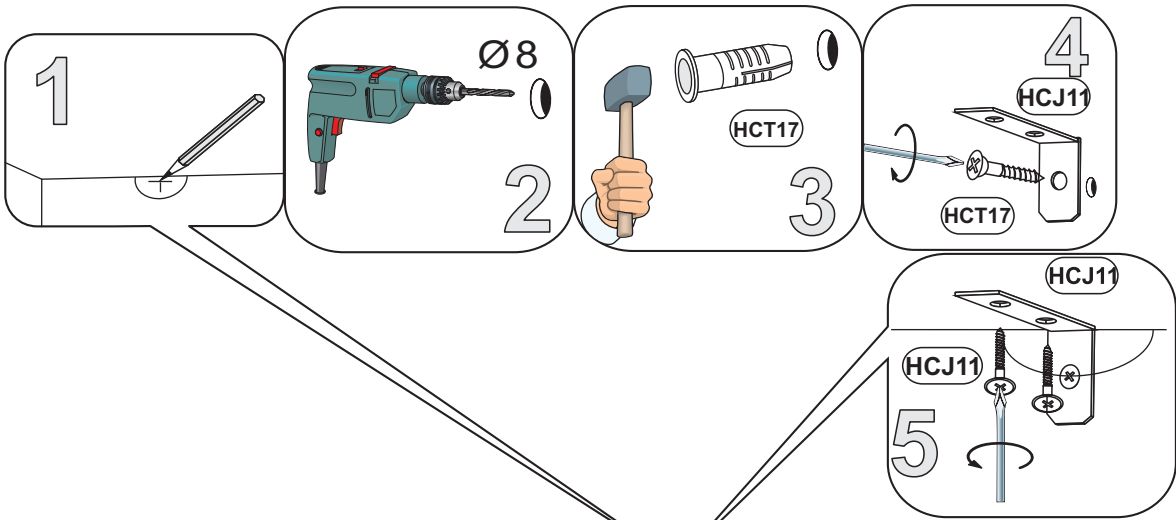

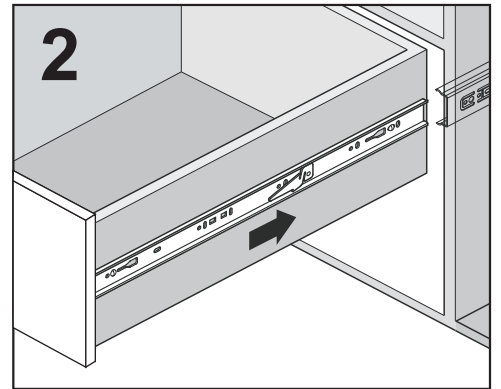
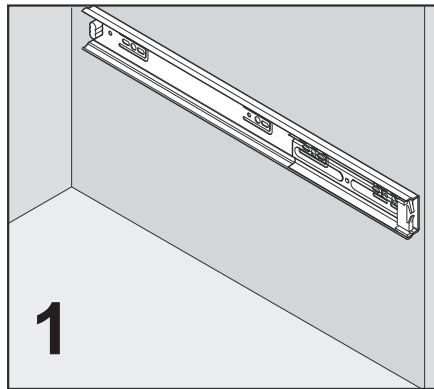
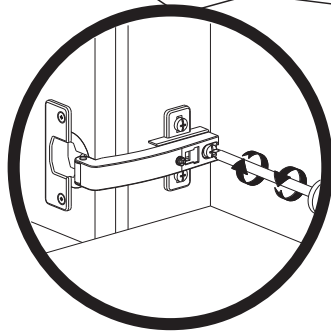
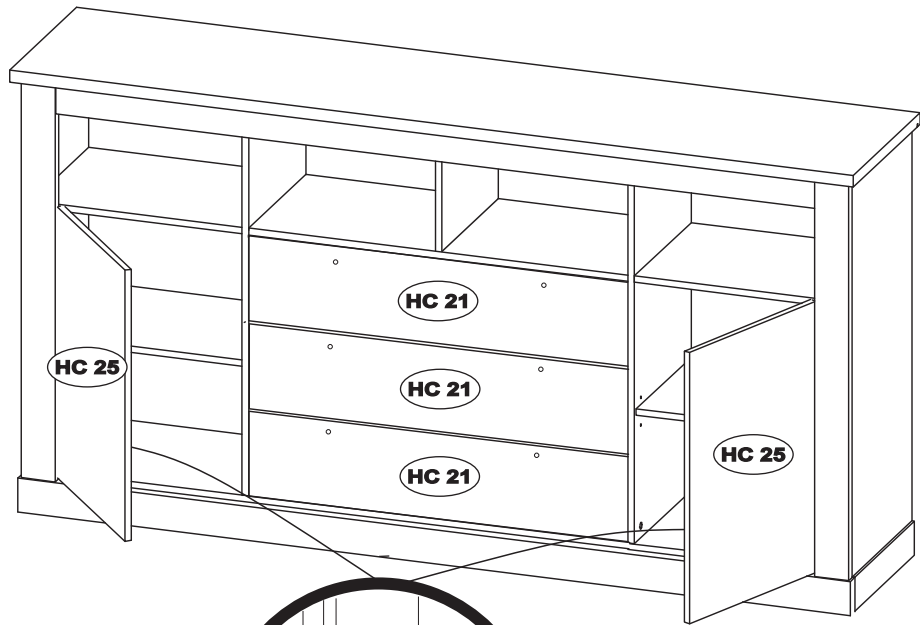

HCZ2 + HCD14

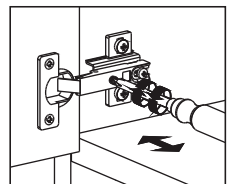
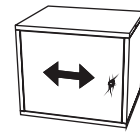
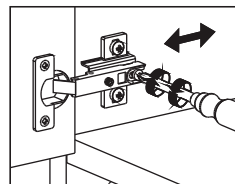
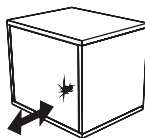
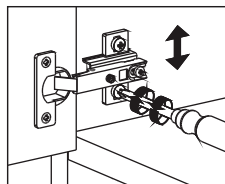
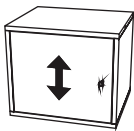

HCZ4 + HCD14

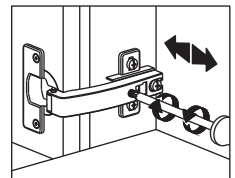
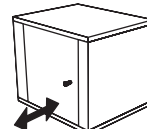
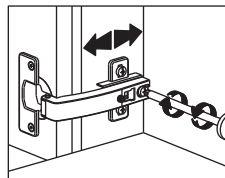
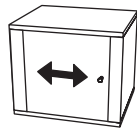
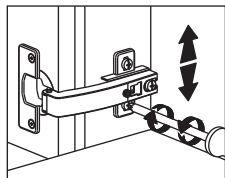
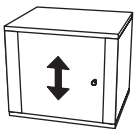

HCC115 153495  
φ20 x38

HCA6 2549  
WPM 4x22 x6

HCUC1 154537  
x6

HCUC160 154536  
x2

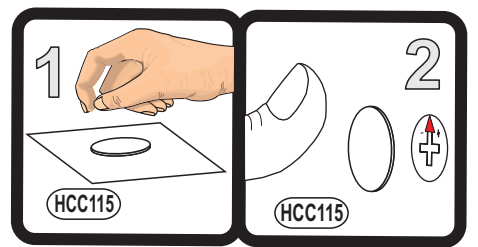
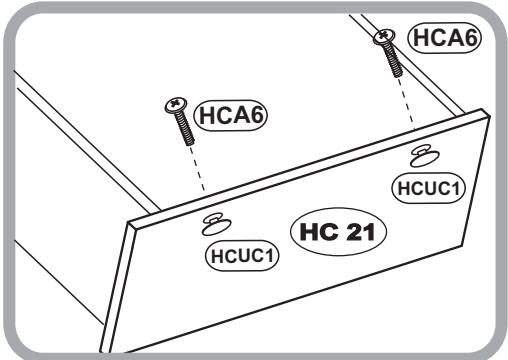
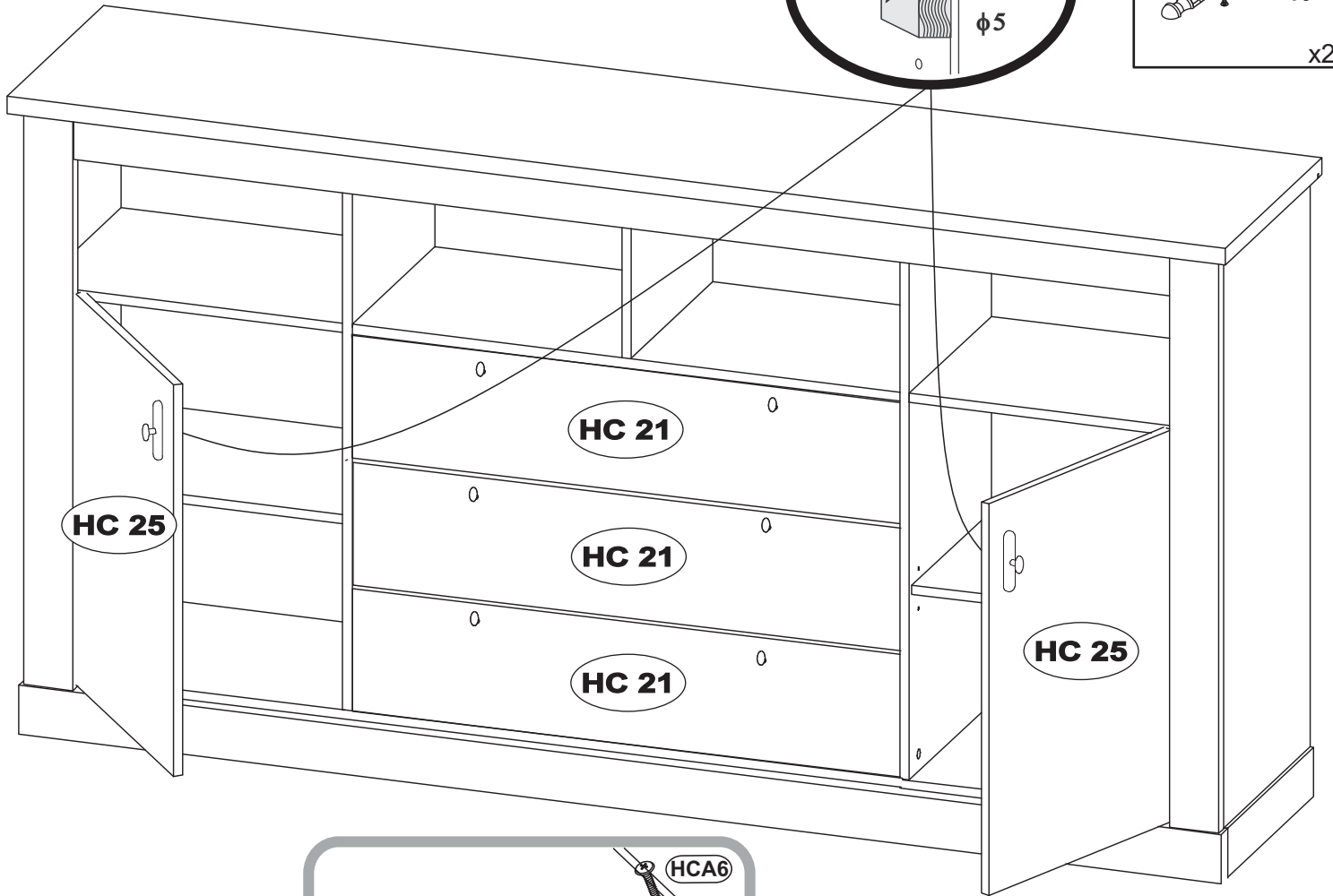
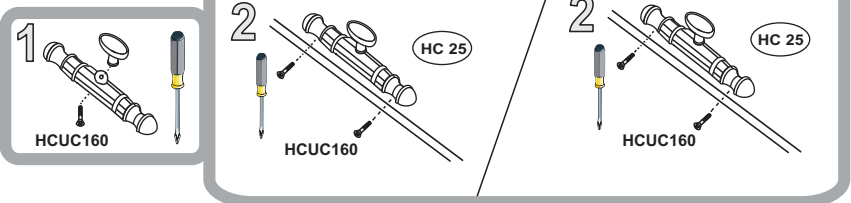

# CHAMBORD 55

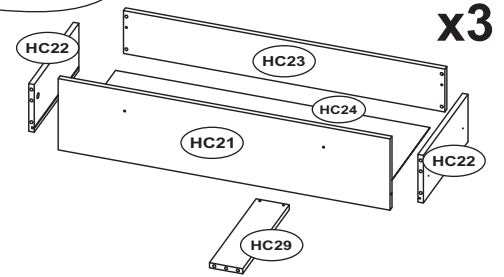
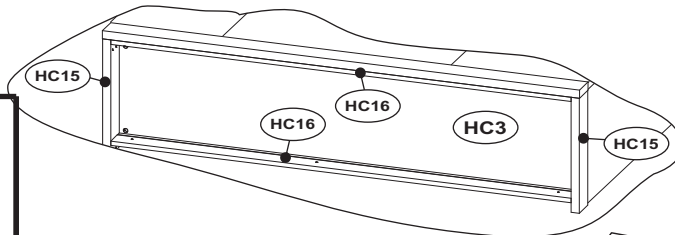
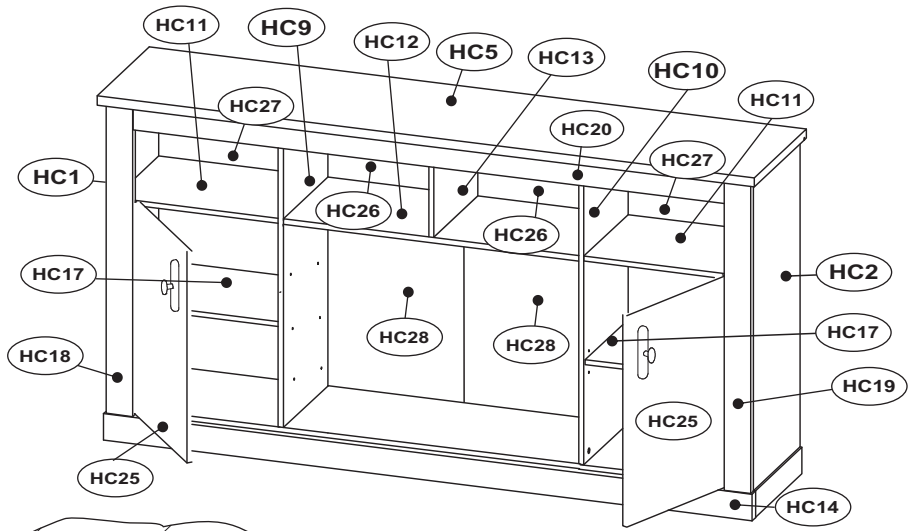

**D** Unser Direktservice für Beschlagteile  
Sollte Ihnen ein Beschlagteil fehlen, können Sie diese Servicekarte direkt an die untenstehende Adresse mailen. Wir können allerdings nur Beschlagteile auf diesem Wege verschicken. Sollten Sie eine andere Beanstandung an Ihrem Möbelstück haben, so wenden Sie sich bitte direkt an Ihr Möbelhaus.

**GB** Our direct order service for fitting  
If a fitting part is missing, you can e-mail this service card directly to the address below. However, we can only send fitting parts in this way. If you have any other cause for complaint concerning your item of furniture, please contact your furniture store directly.

**CZ** Naše přímé služby pro kování  
Chybí-li vám nějaký díl z kování, můžete tuto servisní kartu odeslat e-mailem přímo na níže uvedenou adresu. Touto cestou však můžeme zoslat jen díly kování. Pokud byste reklamovali jiný díl nábytku, obraťte se přímo na svého prodejce nábytku.

**F** Bien étudier la notice de montage  
S'il vous manque une ferrure, veuillez envoyer directement la présente carte service à l'adresse e-mail indiquée ci-dessous. Cependant, ceci nous permet uniquement d'envoyer des ferrures. Pour tout autre type de réclamation concernant votre meuble, veuillez contacter directement votre magasin d'ameublement.

**I** Il nostro servizio diretto per l'ordine della ferramenta  
Qualora Vi dovesse mancare un pezzo di fissaggio, allora Vi preghiamo di inviare questa carta di servizio immediatamente all'indirizzo sottostante. Possiamo inviare i pezzi di fissaggio solamente per mezzo di questo procedimento. Qualora doveste avere qualche altra reclamazione in merito al mobile, allora Vi preghiamo di rivolgervi direttamente al Vostro Negozio di mobili.

**BG** Нашата директна услуга за обков  
Ако липсват части от комплекта, попълнете настоящата сервисна карта и ни я изпратете на e-mail адреса, посочен по-долу. По този начин можем да доставим само липсващи елементи от обкова. Ако установите други дефекти по мебелите, Ви съветваме да се обърнете към мебелната къща/магазин, от който сте закупили стоката.

**NL** Onze directservice voor losse onderdelen  
Wanneer er een onderdeel ontbreekt, kunt u deze servicekaart direct aan onderstaand e-mailadres sturen. Wij kunnen langs deze weg echter alleen beslagdelen versturen. Mocht u een ander probleem aan uw meubel hebben, verzoeken wij u contact op te nemen met uw meubeldealer.

**PL** Nasz bezpośredni serwis części montażowych  
Jeżeli brakuje części koniecznych do montażu, prosimy o przesłanie nam niniejszej karty serwisowej na niżej podany adres e-mailowy. W ten sposób możemy przesłać Państwu tylko brakujące części. W przypadku innych reklamacji dotyczących mebla, prosimy zgłosić się do salonu meblowego, w którym został dokonany zakup.

**HR** Servis za okove  
U slučaju da nedostaje neki od dijelova molimo vas da na dolje navedenu mail adresu pošaljete ovaj servisni obrazac. Na ovaj način mogu se dostaviti samo okovi. U slučaju da imate dodatne prigovore vezane uz komad namještaja molimo vas da se obratite izravno trgovini namještaja gdje je isti kupljen.

**HU** Direktcsopátlunk vasalatak esetén  
Ha hiányzik egy vasalatak, ezt a kártyát közvetlenül elküldheti az alább található címre. Azonban csak vasalatosokat tudunk így küldeni. Amennyiben másfajta reklamáció áll fenn bútorárbaját illetően, forduljon közvetlenül a bútortházhoz.

**SK** Naš priamy servis pre časti kovania  
Ak by Vám chýbala nejaká časť kovania, môžete poslať túto servisnú kartu pošlou e-mailom na nižšie uvedenú adresu. Díly kovania vieme poslať iba týmto spôsobom. Ak by ste mali inú reklamáciu ohľadom Vášho nábytku, obraťte sa priamo na Vašu predajňu nábytku.

**SLO** Naše direktne uslužne storitve za okovje  
Če vam manjka kakšno okovje, lahko to servisno kartico pošljete po e-pošti direktno na spodnji naslov. Po tej poti vam lahko pošljemo samo okovje. Če želite reklamirati kakšen drug del pohištva, se obrnite neposredno na vašo trgovino pohištva.

**RO** Service-ul nostru direct pentru feronerie  
In cazul in care va lipseste o piesa de feronerie puteti sa trimiteți direct acest card de service prin e-mail la adresa de mai jos. Noi nu putem expedia piese de feronerie decât pe această cale. Dacă aveți o altă reclamație referitoare la piesa de mobilier, atunci vă rugăm să vă adresați direct la magazinul dvs. de mobilier.

**RUS** Наш прямой сервис для поставок фурнитуры  
Если окажется, что Вам не хватает того или иного элемента фурнитуры, Вы можете отправить сервисную карту по факсу непосредственно на нижеприведенный адрес электронной почты. Однако, таким образом мы можем пересылать лишь фурнитуру. Если же у Вас возникнут иные претензии относительно приобретенной мебели, пожалуйста, обращайтесь непосредственно в организацию, осуществившую продажу.

**S** Vår direktservice för beslagsdelar  
Om du saknar en beslagsdel kan du skicka detta servicekort direkt till e-postadressen som anges nedan. Tänk på att detta är den enda möjligheten att skicka beslagsdelar till dig. Om du vill reklamera din möbel av en annan anledning misstär du kontakta ditt möbelförstär.

**ES** Nuestro servicio directo para accesorios  
Si le falta algún accesorio, puede enviar esta tarjeta de servicio directamente a la siguiente dirección. No obstante, por este método solo podemos enviar accesorios. Si tiene alguna otra objeción sobre su mueble, consulte directamente con su mueblería.

**TR** Donatılar için doğrudan servisimiz  
Bir donatınız eksikse bu servis kartını doğrudan aşağıda bulunan adrese doğrudan mail yazabilirsiniz. Sadece bu yolla donatıları gönderebiliriz. Mobilyanızda başka şikayetleriniz varsa lütfen doğrudan mobilya satıcınıza danışın.

AI No.	Qty	H	W	D	PKG
HC1	x1	932	389	15	1/2
HC2	x1	932	389	15	1/2
HC3	x1	1909	369	15	2/2
HC5	x1	1979	431	28	1/2
HC9	x1	917	368	15	1/2
HC10	x1	917	368	15	1/2
HC11	x2	494	367	15	2/2
HC12	x1	890	367	15	2/2
HC13	x1	289	366	15	1/2
HC14	x1	1954	80	28	2/2
HC15	x2	386	80	28	2/2
HC16	x2	1896	80	15	2/2
HC17	x2	493	360	15	2/2
HC18	x1	932	80	22	2/2
HC19	x1	932	80	22	2/2
HC20	x1	1781	70	18	2/2
HC21	x3	899	210	15	1/2

AI No.	Qty	H	W	D	PKG
HC22	x6	332	140	15	1/2
HC23	x3	871	126	15	2/2
HC24	x3	852	354	2,5	1/2
HC25	x2	636	435	15	2/2
HC26	x2	302	451	2,5	2/2
HC27	x2	937	507	2,5	2/2
HC28	x2	634	451	2,5	2/2
HC29	x3	347	90	15	2/2

# CHAMBORD 55

**D** Unser Direktservice für Beschlagteile  
Sollte Ihnen ein Beschlagteil fehlen, können Sie diese Servicekarte direkt an die untenstehende Adresse mailen. Wir können allerdings nur Beschlagteile auf diesem Wege verschicken. Sollten Sie eine andere Beanstandung an Ihrem Möbelstück haben, so wenden sie sich bitte direkt an Ihr Möbelhaus.

**GB** Our direct order service for fitting  
If a fitting part is missing, you can e-mail this service card directly to the address below. However, we can only send fitting parts in this way. If you have any other cause for complaint concerning your item of furniture, please contact your furniture store directly.

**CZ** Naše přímé služby pro kování  
Chybí-li vám nějaký díl z kování, můžete tuto servisní kartu odeslat e-mailem přímo na níže uvedenou adresu. Touto cestou však můžeme rozesílat jen díly kování. Pokud byste reklamovali jiný díl nábytku, obraťte se přímo na svého prodejce nábytku.

**F** Bien étudier la notice de montage  
S'il vous manque une ferrure, veuillez envoyer directement la présente carte service à l'adresse e-mail indiquée ci-dessous. Cependant, ceci nous permet uniquement d'envoyer des ferrures. Pour tout autre type de réclamation concernant votre meuble, veuillez contacter directement votre magasin d'ameublement.

**I** Il nostro servizio diretto per l'ordine della ferramenta  
Qualora Vi dovesse mancare un pezzo di fissaggio, allora Vi preghiamo di inviare questa carta di servizio immediatamente all'indirizzo sottostante. Possiamo inviare i pezzi di fissaggio solamente per mezzo di questo procedimento. Qualora dovete avere qualche altra reclamazione in merito al mobile, allora Vi preghiamo di rivolgerVi direttamente al Vostro Negozio di mobili.

**BG** Нашата директна услуга за обкоя  
Ако липсват части от комплекта, потържете настоящата сервисна карта и ни я изпратете на e-mail адрес, посочен по-долу. По този начин можем да доставяме само липсващи елементи от обкоя. Ако установите други дефекти по мебелите, Ви съветваме да се обърнете към мебелната къща/магазин, от който сте закупили стоката.

**NL** Onze directservice voor losse onderdelen  
Wanneer er een onderdeel ontbreekt, kunt u deze servicekaart direct aan onderstaand e-mailadres sturen. Wij kunnen langs deze weg echter alleen bestelgedelen versturen. Mocht u een ander probleem aan uw meubel hebben, verzoeken wij u contact op te nemen met uw meubeldealer.

**PL** Nasz bezpośredni serwis części montażowych  
Jeżeli brakuje części koniecznych do montażu, prosimy o przesłanie nam niniejszej karty serwisowej na niżej podany adres e-mailowy. W ten sposób możemy przesyłać Państwu tylko brakujące części. W przypadku innych reklamacji dotyczących mebla, prosimy zgłosić się do salonu meblowego, w którym został dokonany zakup.

**HR** Servis za okove  
U slučaju da nedostaje neki od dijelova molimo vas da na dolje navedenu mail adresu pošaljete ovaj servisni obrazac. Na ovaj način mogu se dostaviti samo okovi. U slučaju da imate dodatne prigovore vezane uz komad namještaja molimo vas da se obratite izravno trgovini namještaja gdje je isti kupljen.

**HU** Direktszolgáltatunk vasalatok esetén  
Ha hiányzik egy vasalat, ezt a kártyát közvetlenül elküldheti az alább található címre. Azonban csak vasalatokat tudunk így küldeni. Amennyiben másfajta reklamáció áll fenn butordarabját illetően, forduljon közvetlenül a bűtörházhöz.

**SK** Naš priamy servis pre časti kovania  
Ak by Vám chýbala nejaká časť kovania, môžete poslať túto servisnú kartu pošťou e-mailom na nižšie uvedenú adresu. Dieľky kovania vieme poslať iba týmto spôsobom. Ak by ste mali inú reklamáciu oľhadom Vášho nábytku, obráťte sa priamo na Vašu predajňu nábytku.

**SLO** Naše direktne uslužne storitve za okovje  
Ce vam manjka kakšno okovje, lahko to servisno kartico pošljete po e-pošti direktno na spodnji naslov. Po tej poti vam lahko pošljemo samo okovje. Če želite reklamirati kakšen drug del pohištva, se obrnite neposredno na vašo trgovino pohištva.

**RO** Service-ul nostru direct pentru feronerie  
În cazul în care vă lipsește o piesă de feronerie puteți să trimiteți direct acest card de service prin e-mail la adresa de mai jos. Noi nu putem expedia piese de feronerie decât pe această cale. Dacă aveți o altă reclamație referitoare la piesa de mobilier, atunci vă rugăm să vă adresați direct la magazinul dvs. de mobilă.

**RUS** Наш прямой сервис для поставок фурнитуры  
Если окажется, что Вам не хватает того или иного элемента фурнитуры, Вы можете отправить сервисную карту по факсу непосредственно на нижеприведенный адрес электронной почты. Однако, таким образом мы можем переслать лишь фурнитуру. Если же у Вас возникнут иные претензии относительно приобретенной мебели, пожалуйста, обращайтесь непосредственно в организацию, осуществившую продажу.

**S** Vår direktservice för beslagsdelar  
Om du saknar en beslagsdel kan du skicka detta servicekort direkt till e-postadressen som anges nedan. Tänk på att detta är den enda möjligheten att skicka beslagsdelar till dig. Om du vill reklamera din möbel av en annan anledning måste du kontakta ditt möbelhus direkt.

**ES** Nuestro servicio directo para accesorios  
Si le falta algún accesorio, puede enviar esta tarjeta de servicio directamente a la siguiente dirección. No obstante, por este método solo podemos enviar accesorios. Si tiene alguna otra objeción sobre su mueble, consulte directamente con su mueblería.

**TR** Donatılar için doğrudan servisimiz  
Bir donatınız eksikse bu servis kartını doğrudan aşağıda bulunan adrese doğrudan mail yazabilirsiniz. Sadece bu yolla donatıları gönderebiliriz. Mobilyanızda başka şikayetleriniz varsa lütfen doğrudan mobilya satıcınıza danışın.

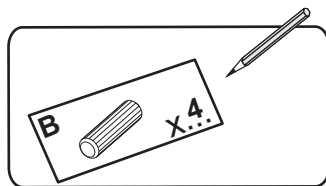

<b>HCB1</b> 8x28 X...	 1018	<b>HCR44</b> L-350 X...	 123165
<b>HCM1</b> X...	 123894	<b>HCS3</b> 3,5x13 X...	 1011
<b>HCT1</b> X...	 11809	<b>HCP13</b> 4x30 X...	 1012
<b>HCJ23</b> X...	 1302	<b>HCF36</b> X...	 1305
<b>HCC115</b> φ20 X...	 153495	<b>HCF14</b> X...	 1021
<b>HCW1</b> X...	 1289	<b>HCA6</b> WPM 4x22 X...	 2549
<b>HCF1</b> X...	 1415	<b>HCF44</b> X...	 116795
<b>HCK15</b> X...	 119573	<b>HCP6</b> 3x20 X...	 1056
<b>HCK13</b> X...	 23482	<b>HCUC1</b> X...	 154537
<b>HCZ4</b> φ35 90° X...	 49365	<b>HCH11</b> X...	 1267
<b>HCD14</b> H4 X...	 23515	<b>HCT3</b> L-64 X...	 15824
<b>HCUC160</b> X...	 154536	<b>HCK1</b> 7x50 X...	 1354