

DE:Installationsanleitung
 UK:Installation Instruction
 FR:Instruction d'installation
 IT:Istruzioni di installazione
 ES: Instrucciones de instalación
 N620P212192

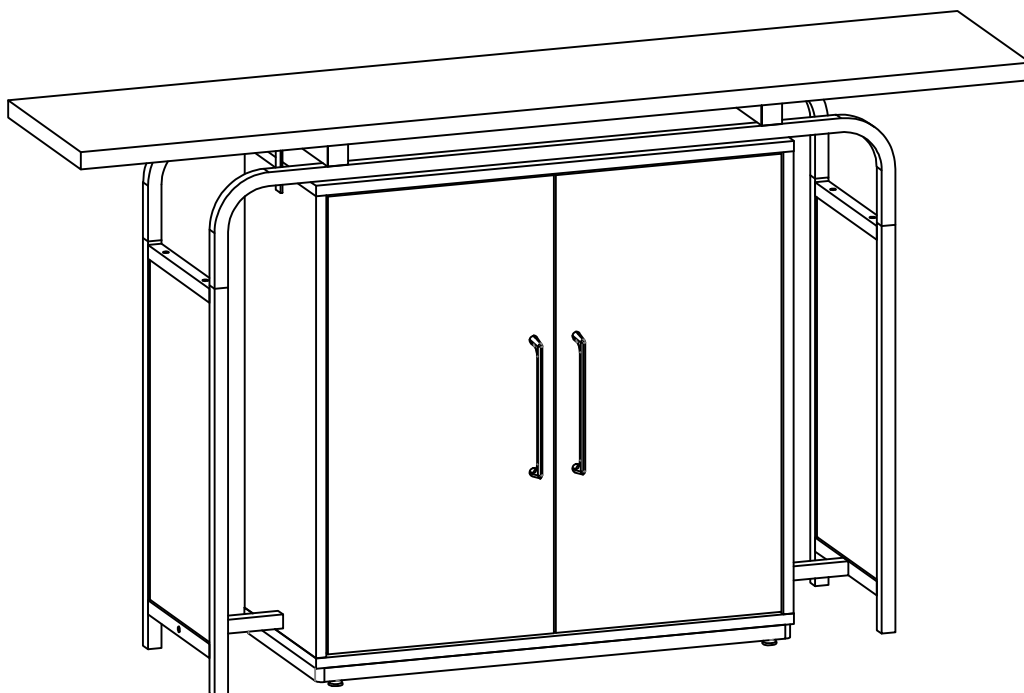

Importeur	Decobus Handel GmbH		
Adresse	Innungsstraße 9,21244 Buchholz, Deutschland		
URL	https://www.decobusgroup.de		
Hersteller	ZHANGZHOU YUCHENG IMPORT & EXPORT CO.,LTD		
Adresse	GUANSHAN INDUSTRY ZONE,CHANGTAI, ZHANGZHOU FUJIAN CHINA		
Email/URL	Elvis@fjgsgg.com.cn		
<table border="1" data-bbox="175 1937 316 2011"> <tr> <td>EC</td> <td>REP</td> </tr> </table>	EC	REP	Decobus Handel GmbH Innungsstraße 9,21244 Buchholz, Deutschland https://www.decobusgroup.de
EC	REP		

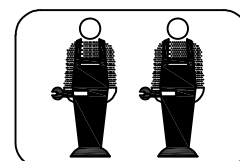

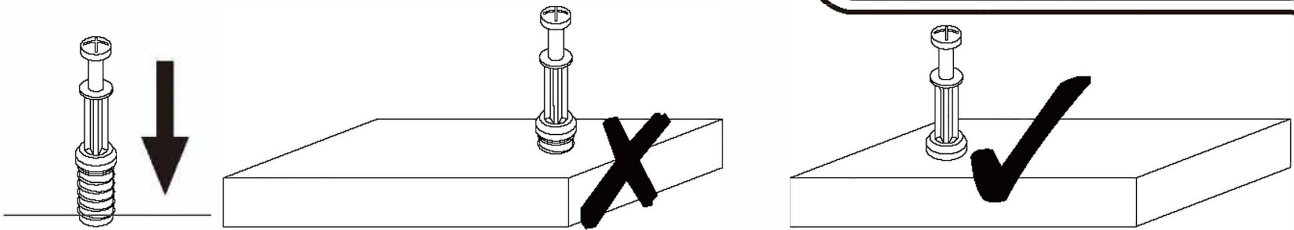

EN_QUICKFIT: Tighten quickfit until shoulder is flush with panel. Do not overtighten or undertighten.

FR_RACCORD RAPIDE: Faites serrer le raccord rapide jusqu'à ce que l'épaulement soit parfaitement encastré dans le panneau. Il ne faut ni trop serrer ni insuffisamment serrer.

ES_QUICKFIT: Apriete quickfit hasta que el hombro se descargue con el panel. NO lo sobreapriete ni lo apriete poco.

DE_QUICKFIT: Ziehen Sie den Quickfit fest, bis die Schulter mit der Platte bündig ist. Bitte nicht zu fest oder zu schwach anziehen.

IT_MONTAGGIO RAPIDO: Stringere il montaggio rapido fino a quando la spalla è a filo con il pannello, non stringere troppo o troppo poco.

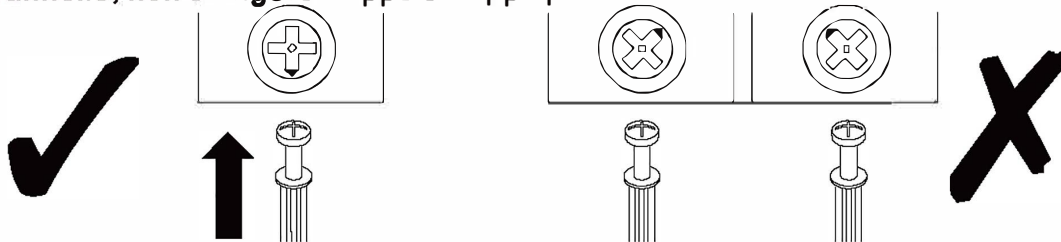

EN_CAM LOCK: When fitting cam lock, ensure starting position is correct before you insert connecting quickfit.

FR_SERRURE BATTEUSE: Avant d'insérer la serrure batteuse, veillez à la bonne orientation avant d'insérer le raccord rapide.

ES_CIERRE DE LA CÁMARA: Cuando instale el cierre de la cámara, asegúrese de que la posición de inicio es correcta antes de que inserte el quickfit conector.

DE_CAM-LOCK: Achten Sie bei der Montage des Cam-Locks auf die richtige Ausgangsposition, bevor Sie den Quickfit einsetzen.

IT_BLOCCAGGIO A CAMMA: Quando si monta il bloccaggio a camma, assicurarsi che la posizione iniziale sia corretta prima di inserire il montaggio rapido di collegamento.

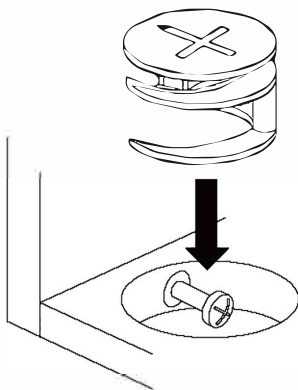

EN_Quickfit head should be in the centre of the cam lock when the two panels are joined.

Cam lock should be inserted before quickfit.

FR_Lorsque les deux panneaux sont assemblés, la tête du raccord rapide doit reposer au centre de la serrure batteuse.

Il faut insérer la serrure batteuse avant le raccord rapide.

ES_El cabezal del quickfit debe estar en el centro del cierre de la cámara cuando se unan los dos paneles.

Se debe insertar el cierre de la cámara antes que el quickfit.

DE_Der Quickfit-Kopf sollte sich in der Mitte des Cam-Locks befinden, wenn die beiden Platten zusammengefügt sind.

Der Cam-Lock sollte vor dem Quickfit eingesetzt werden.

IT_La testa del montaggio rapido deve trovarsi al centro del bloccaggio a camma quando i due pannelli sono uniti.

Il Bloccaggio a Camma deve essere inserito prima del montaggio rapido.

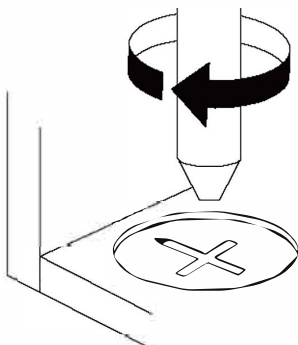

EN_Turn cam lock clockwise to tighten.

FR_Faites tourner la serrure batteuse dans le sens des aiguilles d'une montre pour la resserrer.

ES_Gire el cierre de la cámara en sentido horario para apretarlo.

DE_Drehen Sie den Cam-Lock im Uhrzeigersinn, um ihn festzuziehen.

IT_Ruotare il bloccaggio a camma in senso orario per stringere.

DE:Vor dem Einbau die Schrauben in die Löcher stecken und festziehen, aber nicht bis 100%, 70% bis 80% anziehen reicht aus. Schließlich, nachdem alle Schrauben installiert sind, ziehen Sie alle Schrauben auf 100%.Wenn Sie auf diese Probleme stoßen, wie z. B. Fehlausrichtung der Löcher oder Unfähigkeit, bestimmte Teile zu installieren, überprüfen Sie bitte, ob die Schrauben korrekt verwendet werden und passen Sie die Dichtigkeit der Schrauben an.

UK:Before installation, insert the screws into the holes and tighten them, but do not tighten them to 100%, 70% to 80% is sufficient. Finally, after all screws are installed, tighten all screws to 100%.If you encounter these issues, such as if the holes cannot be aligned or some parts cannot be installed, please check if the screws are used correctly and adjust the tightness of the screws.







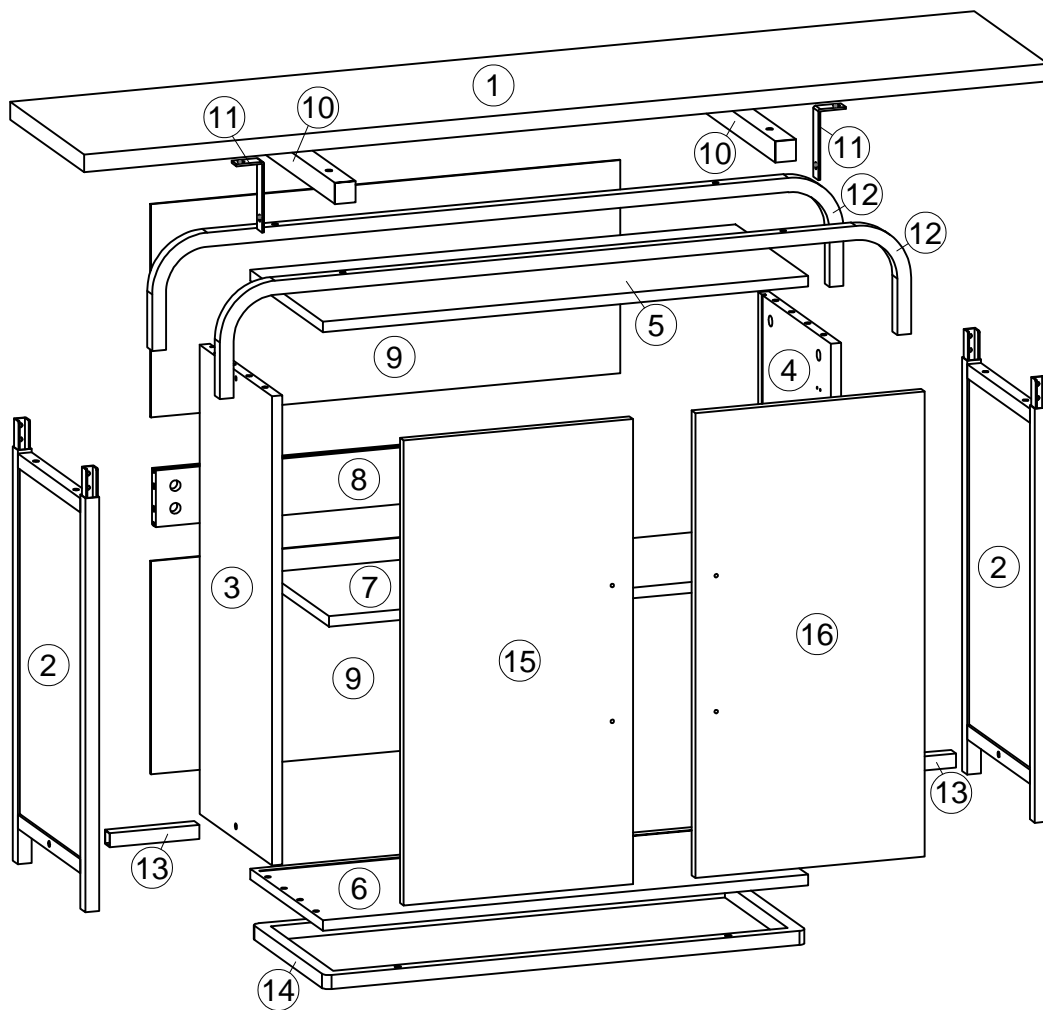



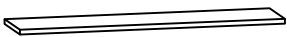

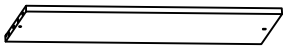

FR:Insérer la vis dans le trou avant la fin de l'assemblage, serrer la vis, mais ne pas serrer à 100%, 70% ~ 80% est correct. Enfin, une fois que toutes les vis sont bien serrées, toutes les vis sont serrées à 100%.Si vous rencontrez ces problèmes, par exemple si les trous ne sont pas alignés ou si certaines pièces ne peuvent pas être montées, vérifiez que les vis sont utilisées correctement et Ajustez leur serrage.

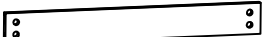
IT:Prima dell'installazione, inserire le viti nei fori e stringerle, ma non al 100%, è sufficiente stringerle al 70% - 80%. Infine, dopo aver installato tutte le viti, stringere tutte le viti al 100%. Se riscontri problemi come disallineamenti dei fori o difficoltà nell'installare alcuni componenti, verifica che le viti siano utilizzate correttamente e regola la tensione delle viti.

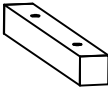





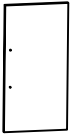



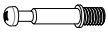





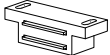

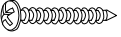

ES: Antes de la instalación, coloque los tornillos en los agujeros y apriételes, pero no al 100%; apretar al 70% - 80% es suficiente. Finalmente, después de haber instalado todos los tornillos, apriete todos los tornillos al 100%. Si se encuentra con problemas como desalineación de los agujeros o dificultad para instalar ciertas piezas, verifique que los tornillos se estén utilizando correctamente y ajuste la tensión de los tornillos

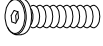

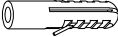

Part List Stückliste

			
①×1pc	②×2pcs	③×1pc	④×1pc
			
⑤×1pc	⑥×1pc	⑦×1pc	⑧×1pc
			
⑨×2pcs	⑩×2pcs	⑪×2pcs	⑫×2pcs
			
⑬×2pcs	⑭×1pc	⑮×1pc	⑯×1pc

Hardware List Hardwareliste

 Ø6×35mm	 Ø15×12mm	 Ø8×30mm		 M4×18mm
Ⓐ×8pcs	Ⓑ×8pcs	Ⓒ×8pcs	Ⓓ×2pcs	Ⓔ×4pcs
 4×35mm			 Ø5×13mm	 3.5×14mm
Ⓕ×4pcs	Ⓖ×2pcs	Ⓗ×2pcs	Ⓘ×4pcs	Ⓝ×40pcs
 4×35mm	 Ø7×47mm	 M6×45mm	 M6×30mm	 M6×12mm
Ⓚ×2pcs	Ⓛ×4pcs	Ⓜ×8pcs	Ⓝ×8pcs	Ⓞ×12pcs
 M4				
Ⓟ×1pc	Ⓠ×1pc	Ⓡ×4pcs	Ⓢ×2pcs	Ⓣ×2pcs
 14×14×9mm				
Ⓤ×8pcs				

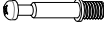
Step 1 Schritt 1

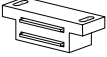
 Ø6×35mm	 3.5×14mm	 G
Ⓐ×8pcs	Ⓝ×4pcs	Ⓖ×2pcs

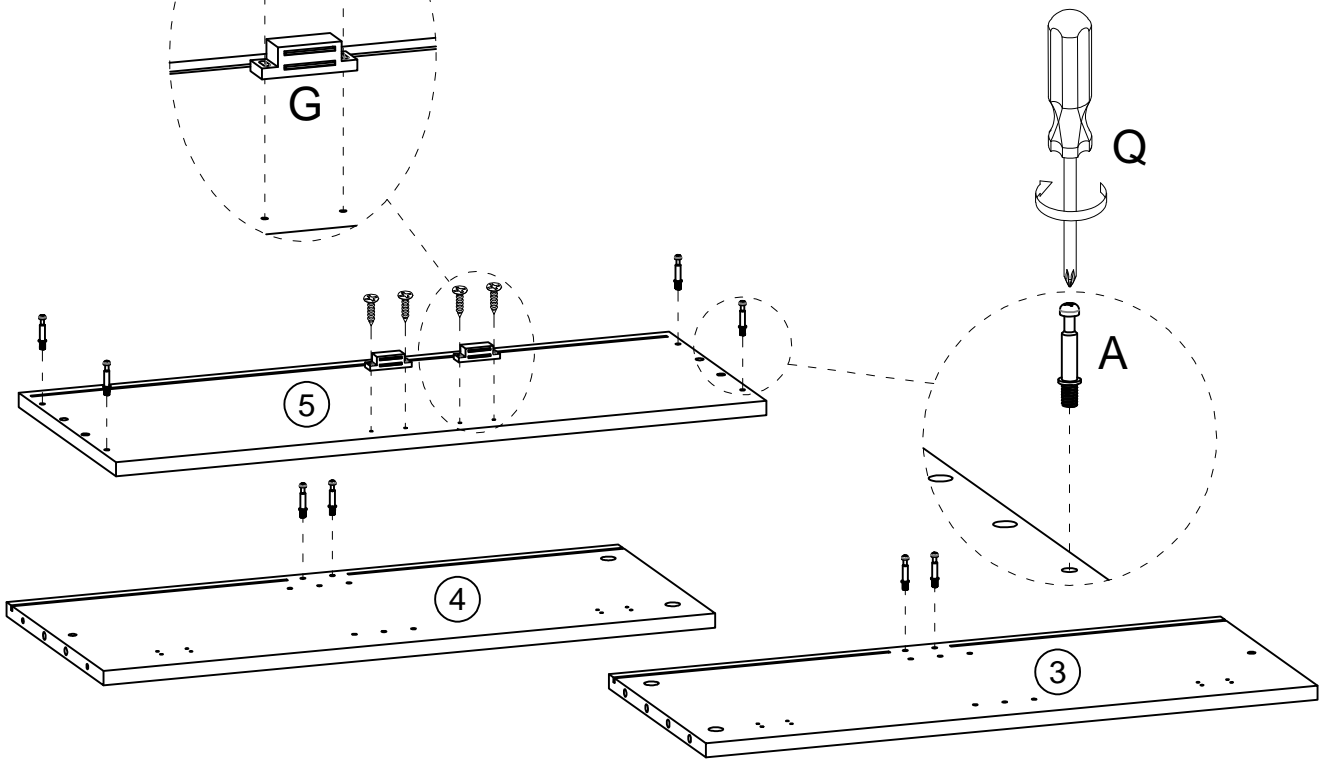

Step 2 Schritt 2

 Ø15×12mm
Ⓑ×4pcs

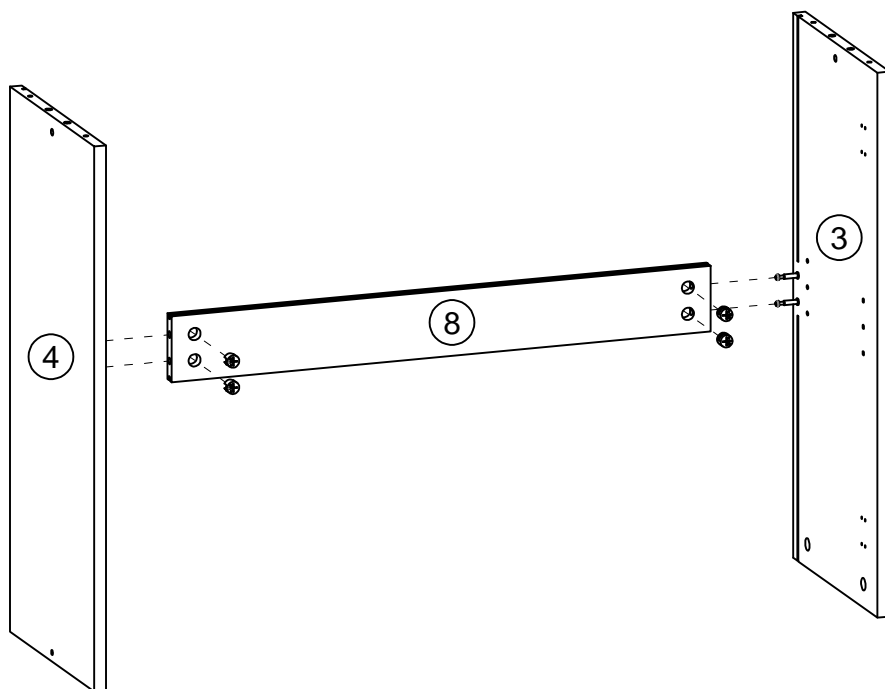

Step 3
Schritt 3

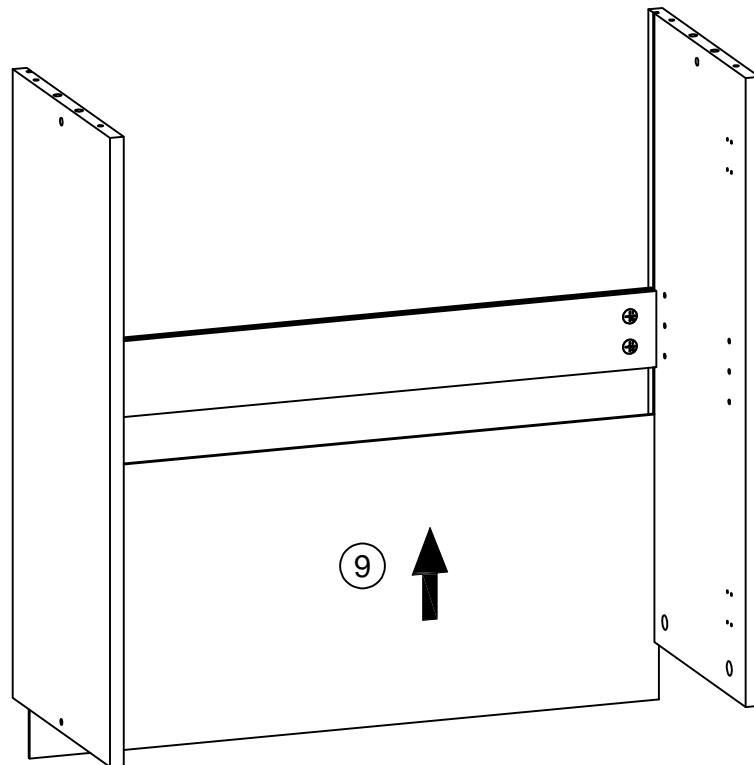

Step 4
Schritt 4

 Ø15×12mm Ⓑ ×4pcs	 Ø8×30mm Ⓒ ×4pcs
--	---

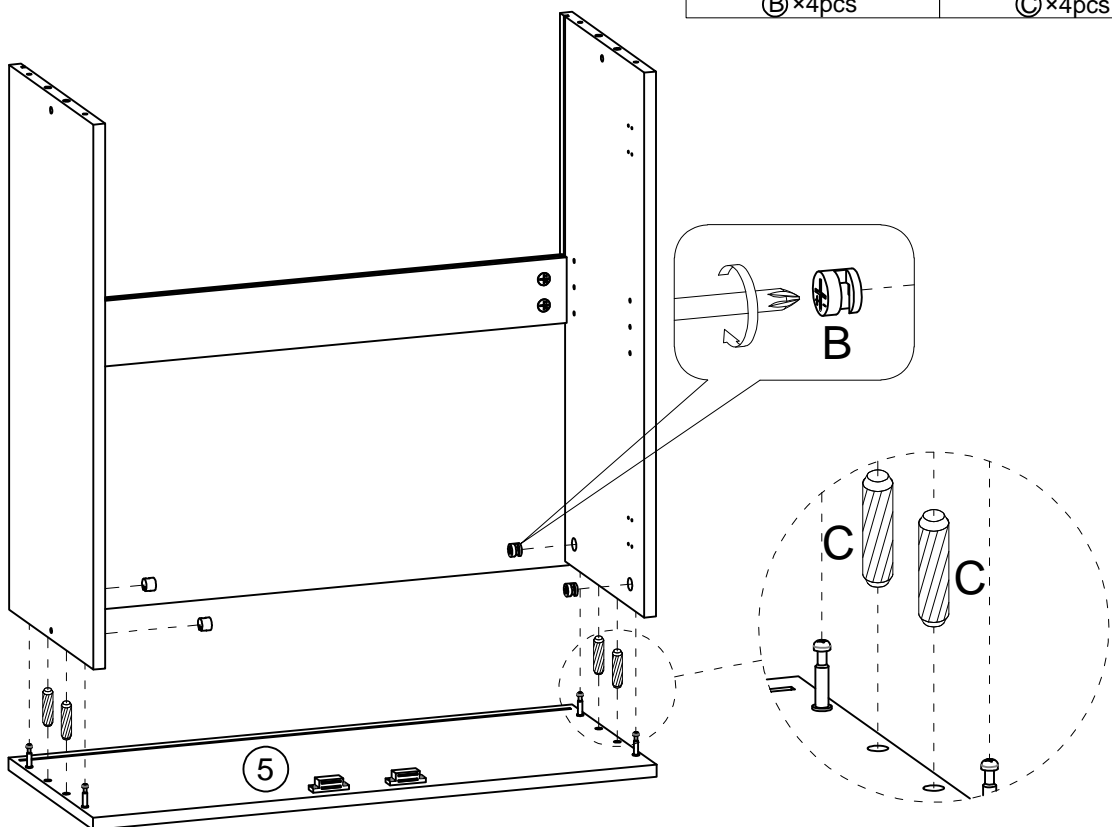

Step 5
Schritt 5

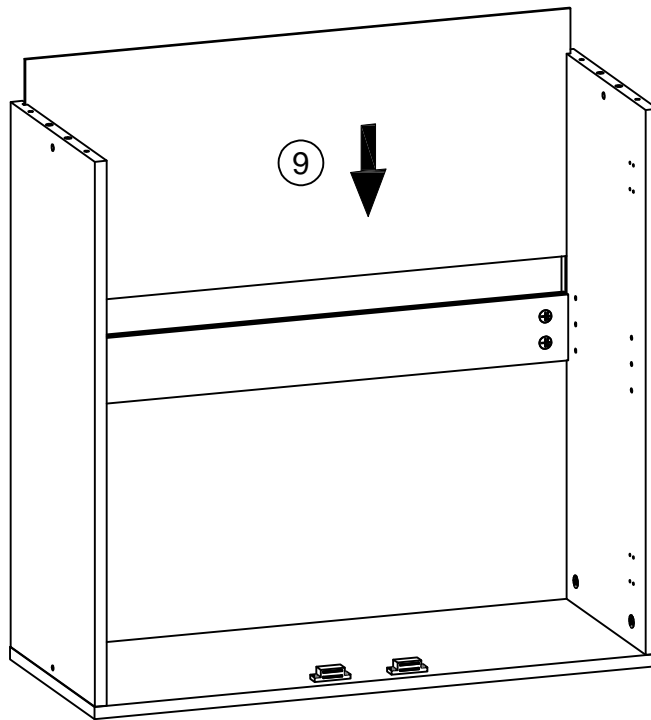

Step 6
Schritt 6

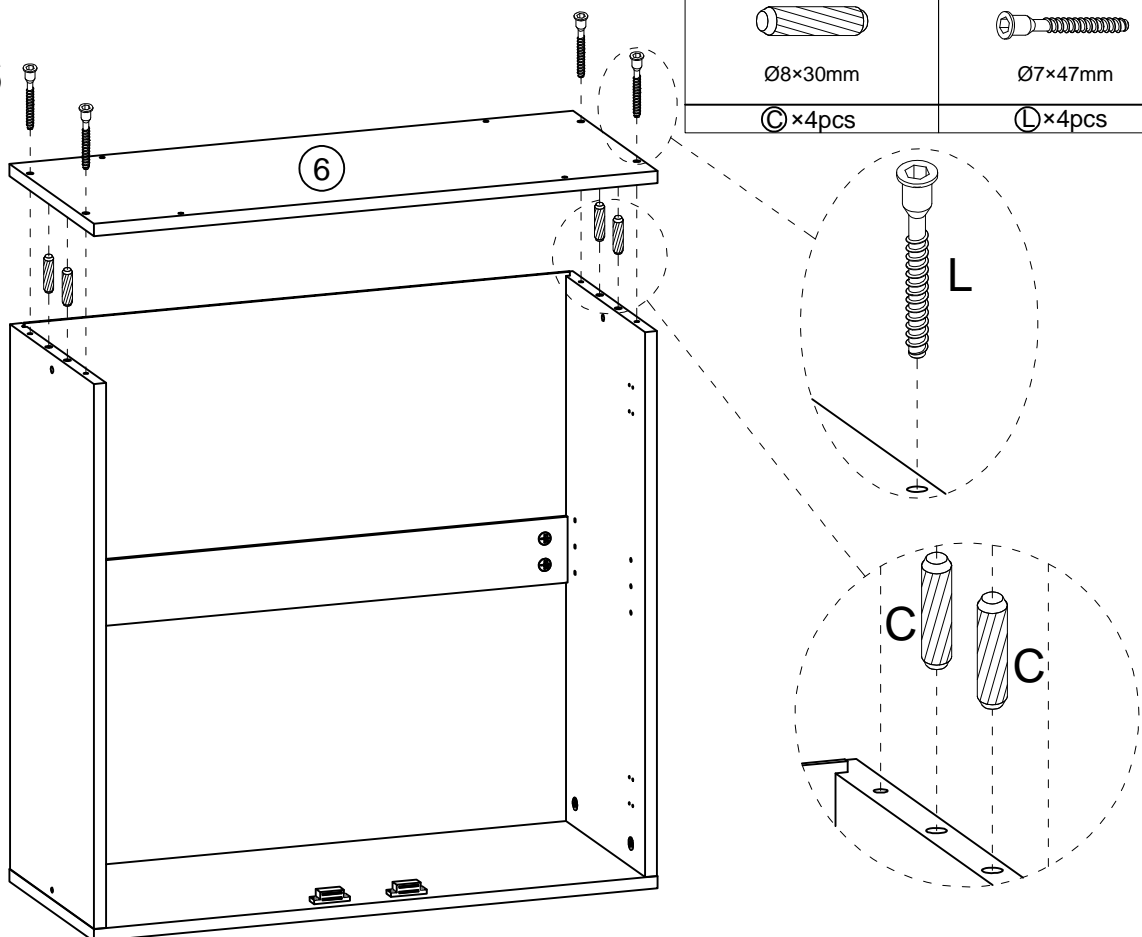

Step 7 Schritt 7



M6×30mm

Ⓝ×4pcs

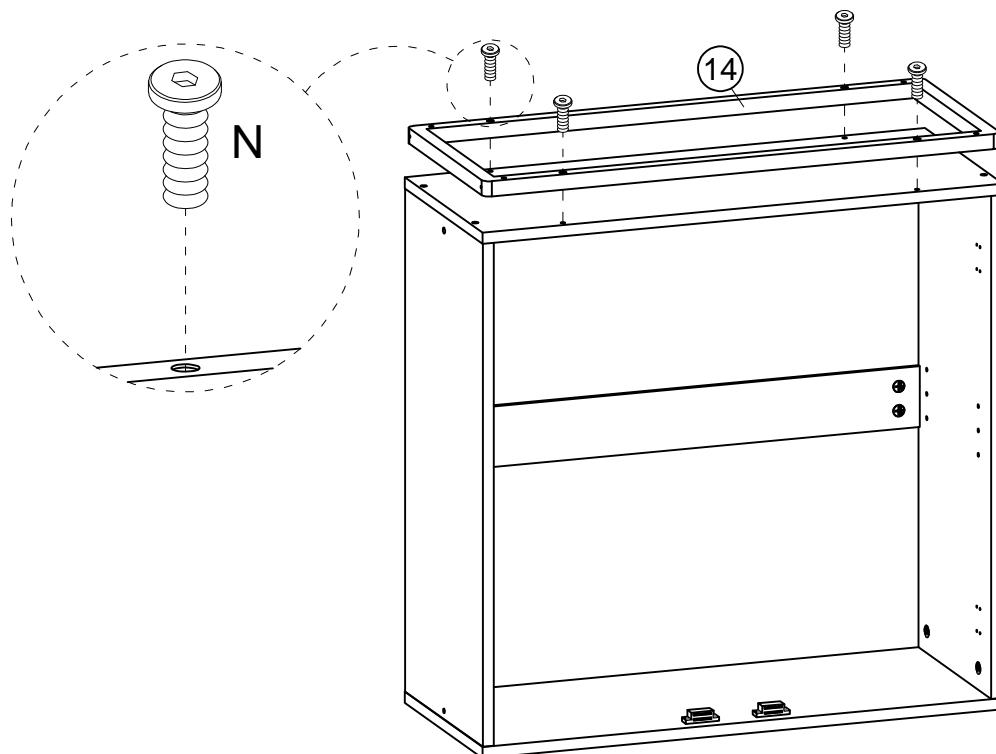

Step 8 Schritt 8



Ⓡ×4pcs

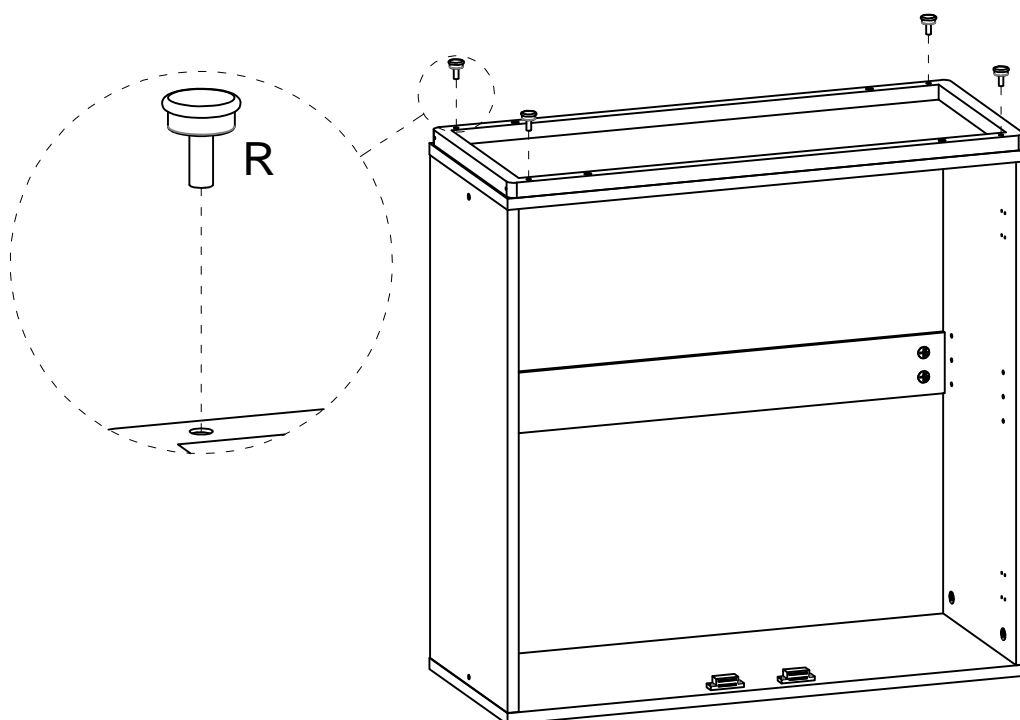

Step 9
Schritt 9

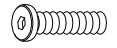

M6×45mm

M ×4pcs

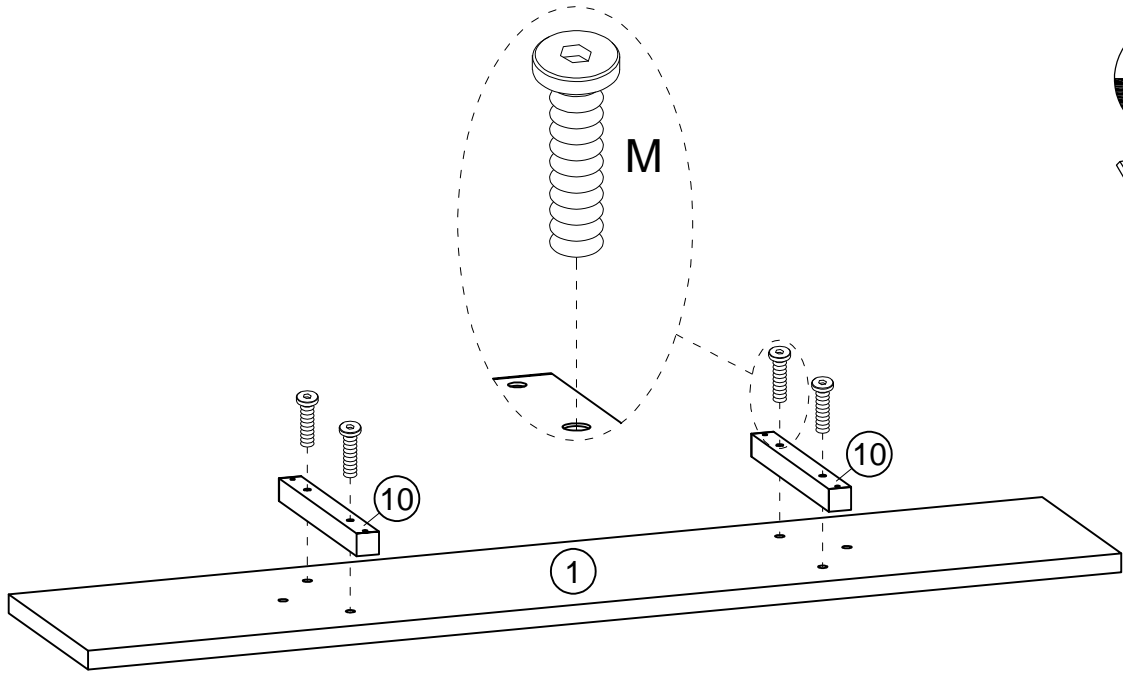

Step 10
Schritt 10



M6×30mm

N ×4pcs

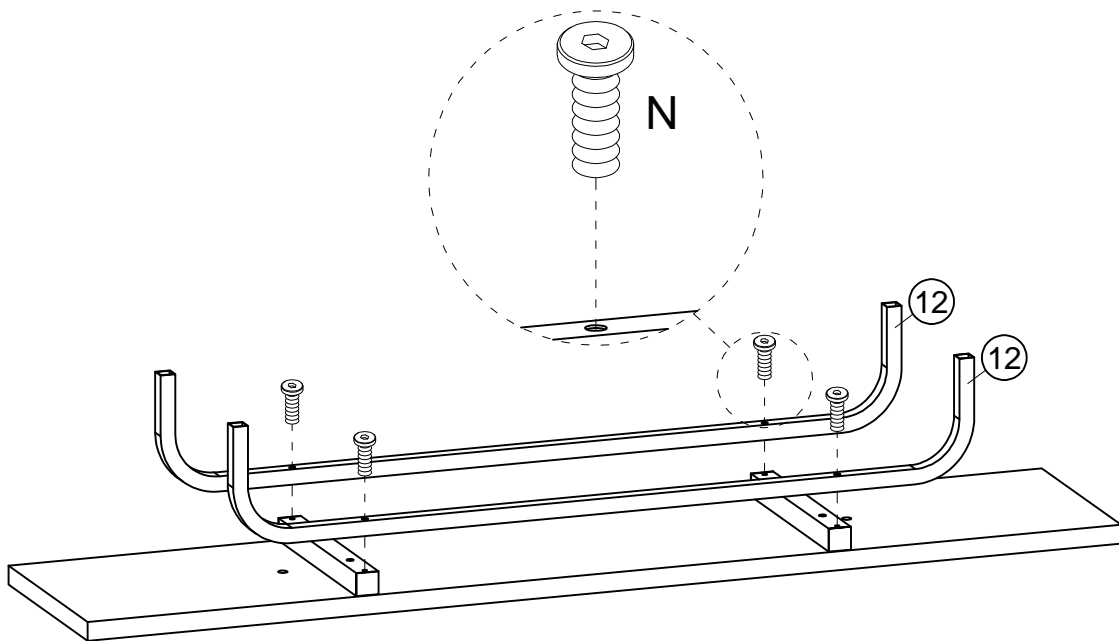

Step 11
Schritt 11



M6×45mm

Ⓜ ×4pcs

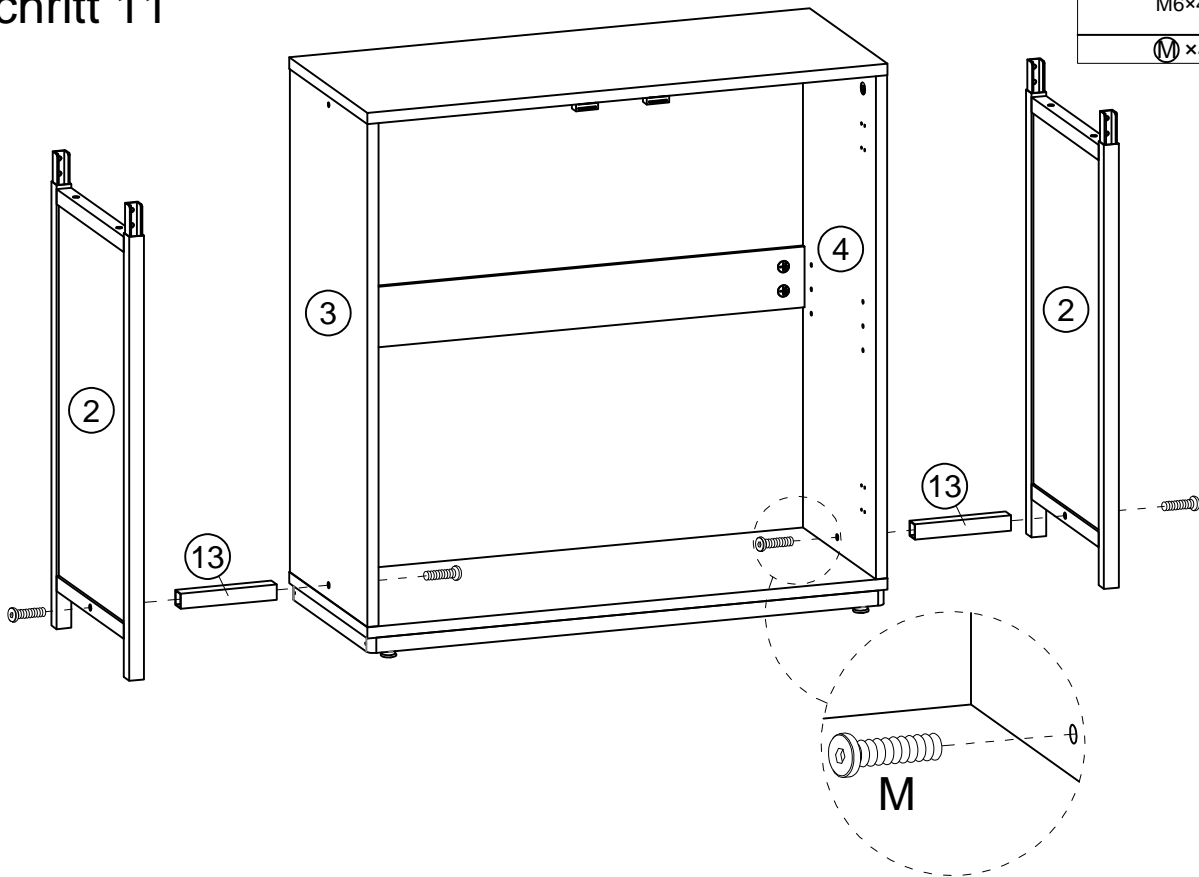

Step 12
Schritt 12





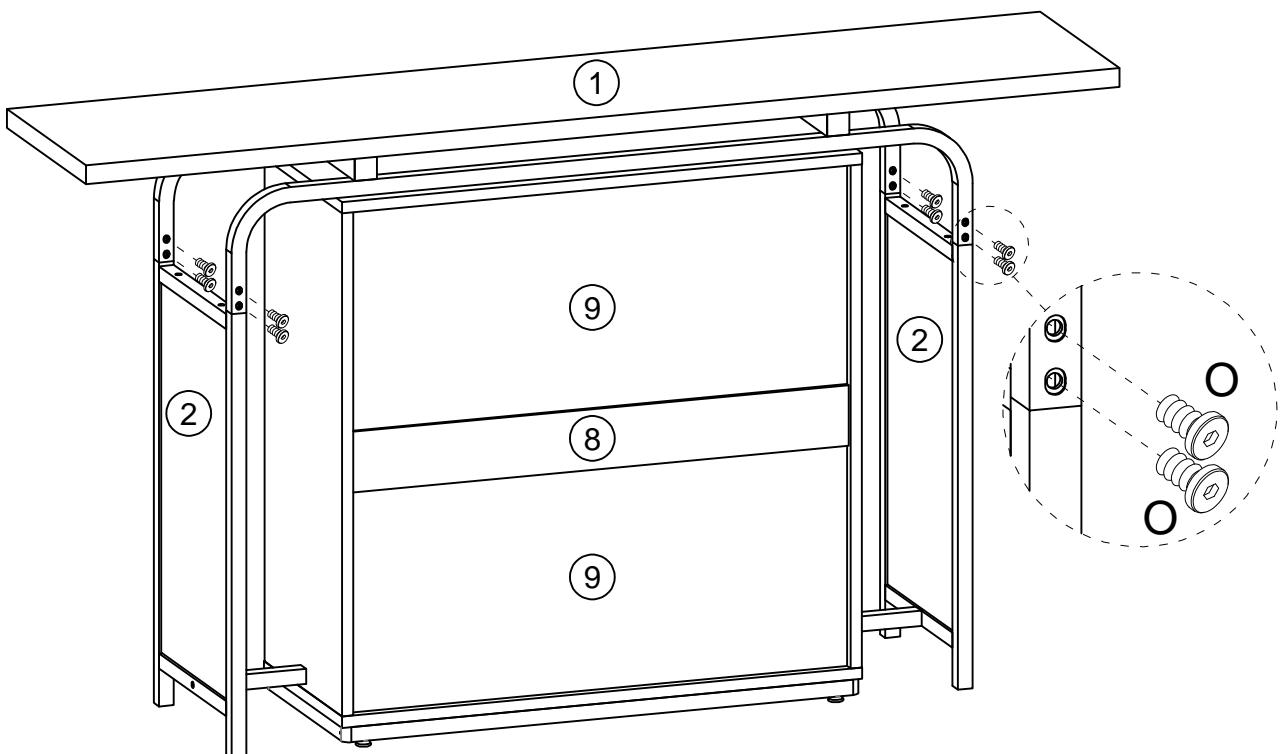

M6×12mm

Ⓞ ×8pcs



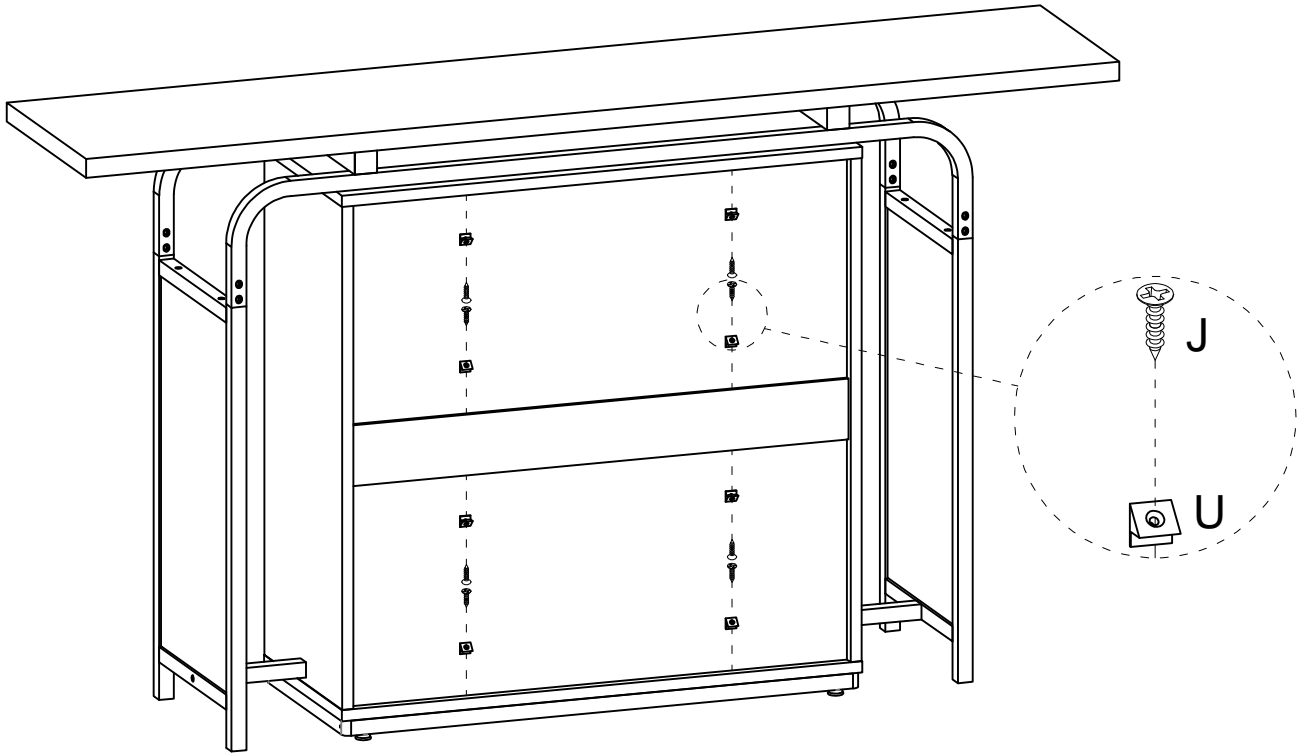

Step 13
Schritt 13

 3.5×14mm	 14×14×9mm
 ×8pcs	 ×8pcs



Step 14
Schritt 14

 M6×12mm
 ×2pcs

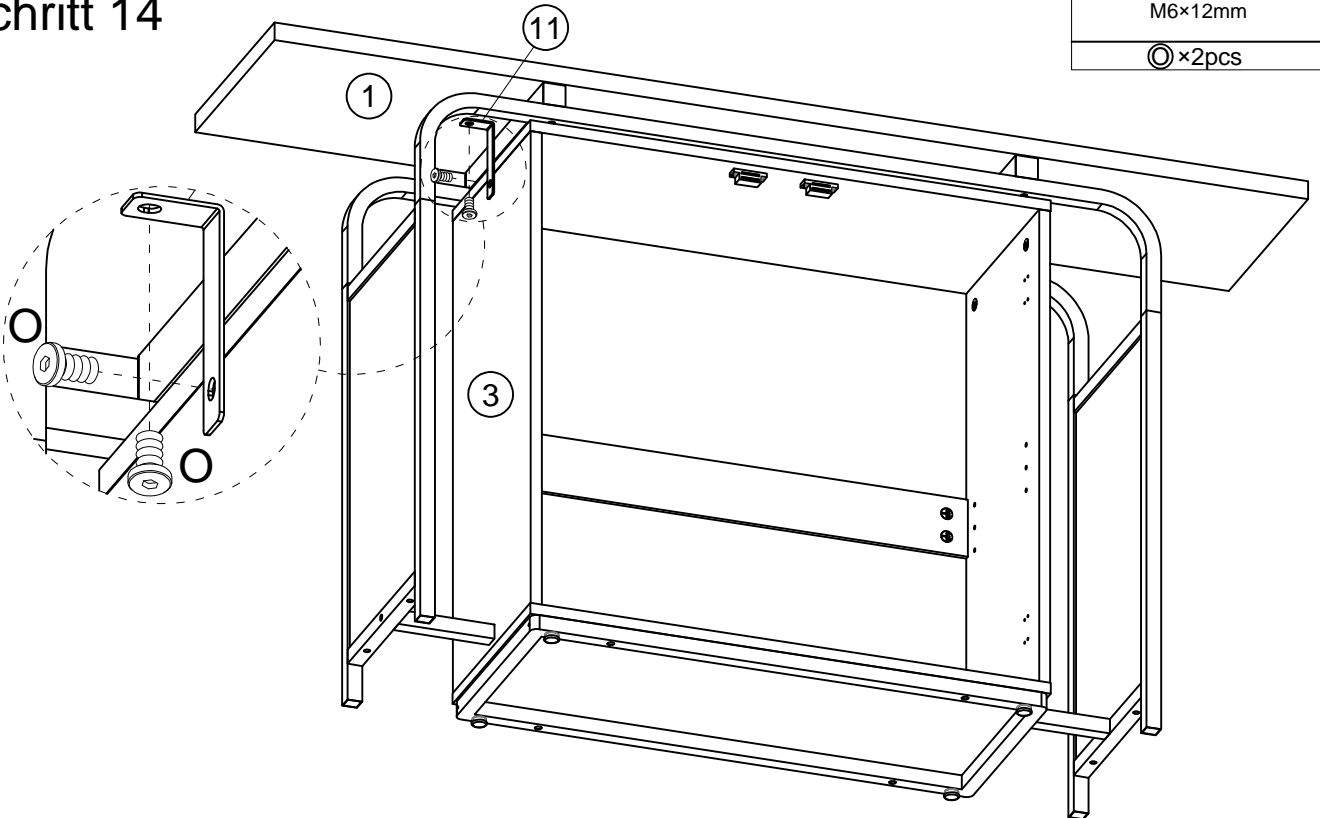

Step 13
Schritt 13



M6×12mm

⊙ ×2pcs

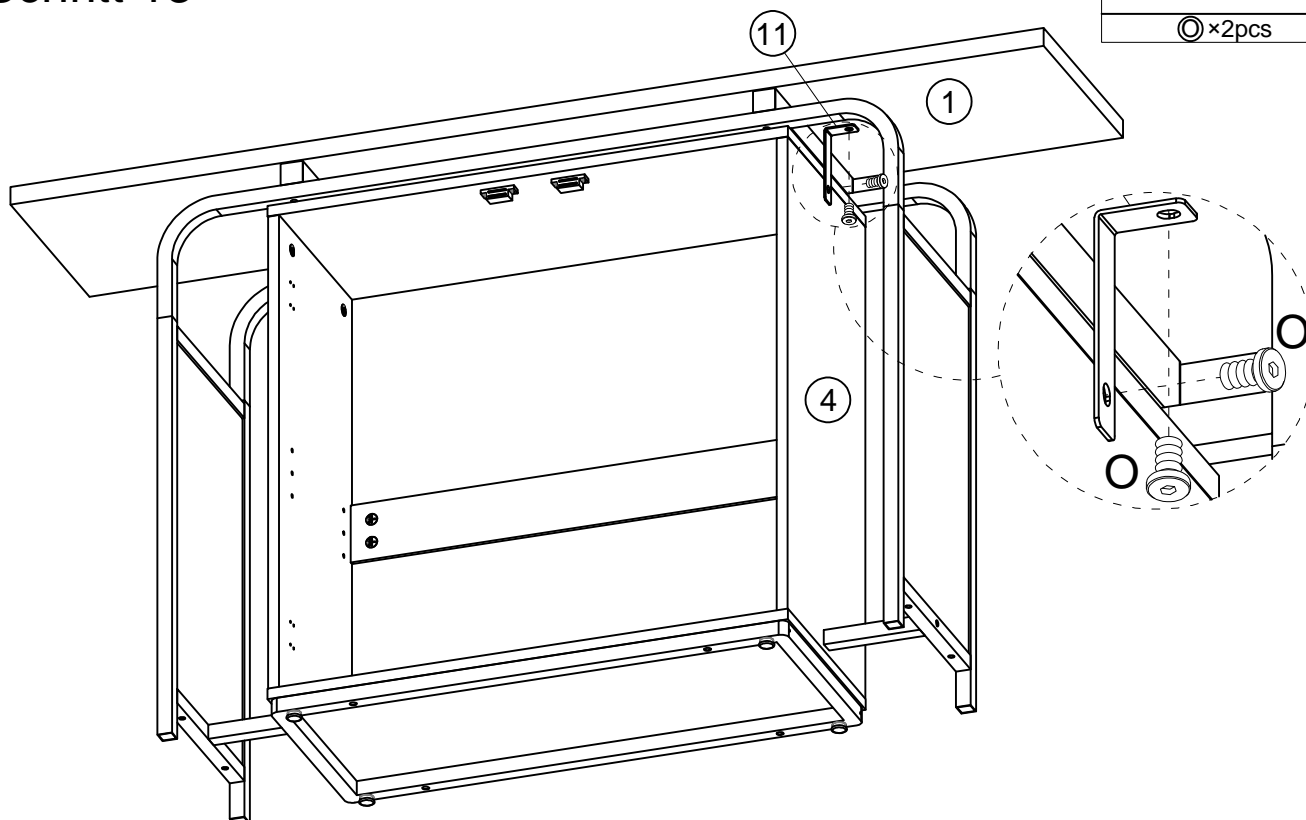

Step 14
Schritt 14



Ø5×13mm

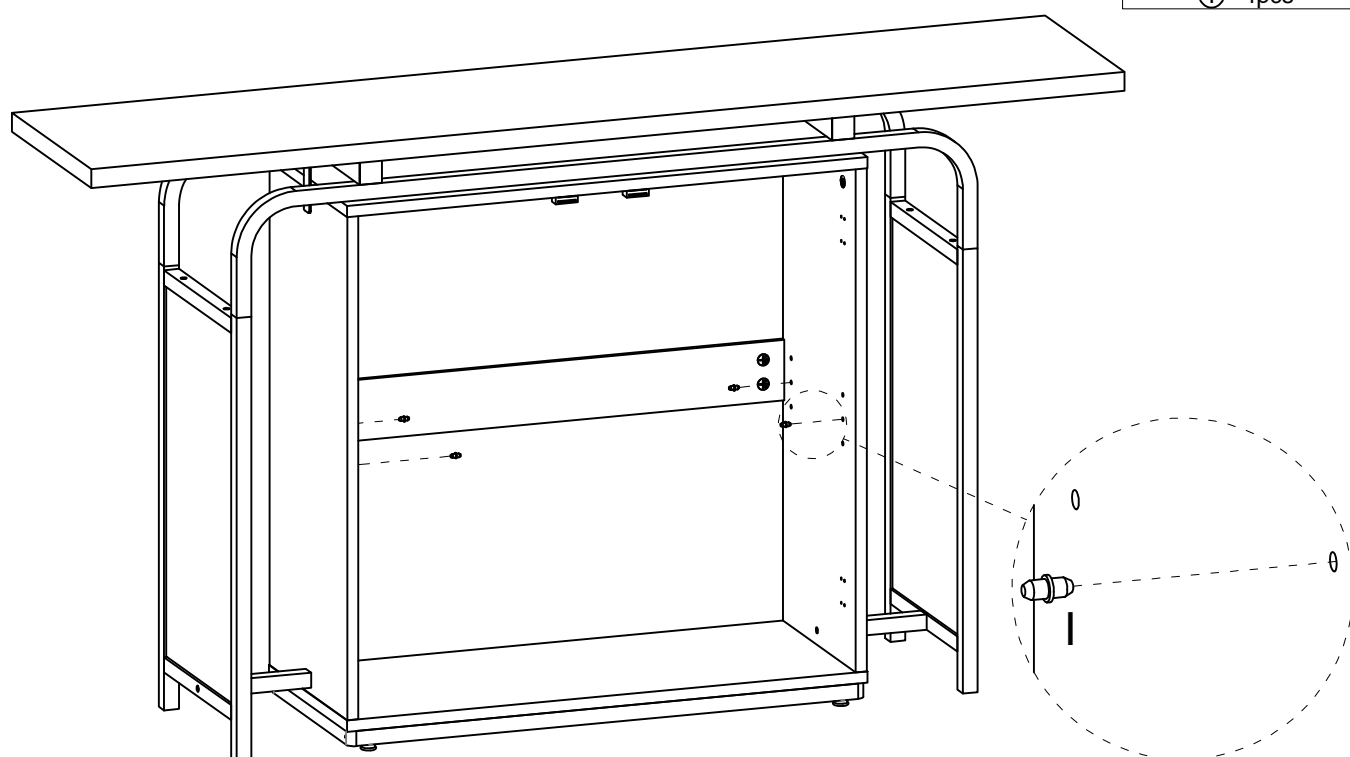

Ⓛ ×4pcs

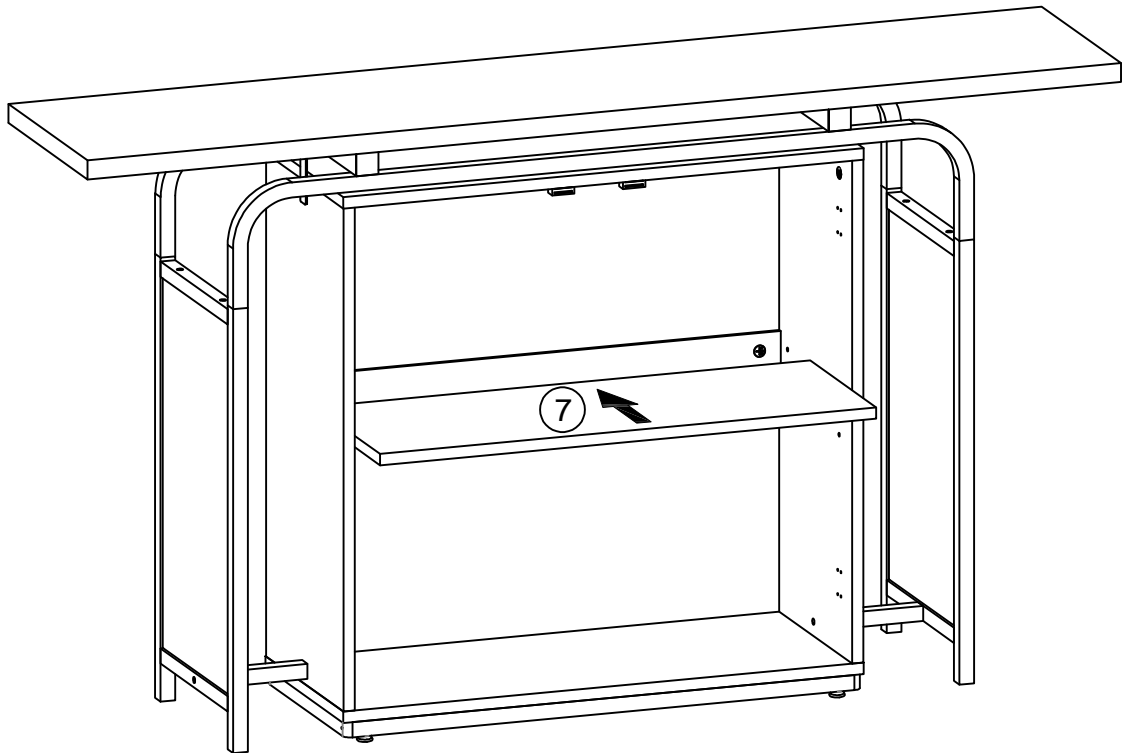

Step 15 Schritt 15



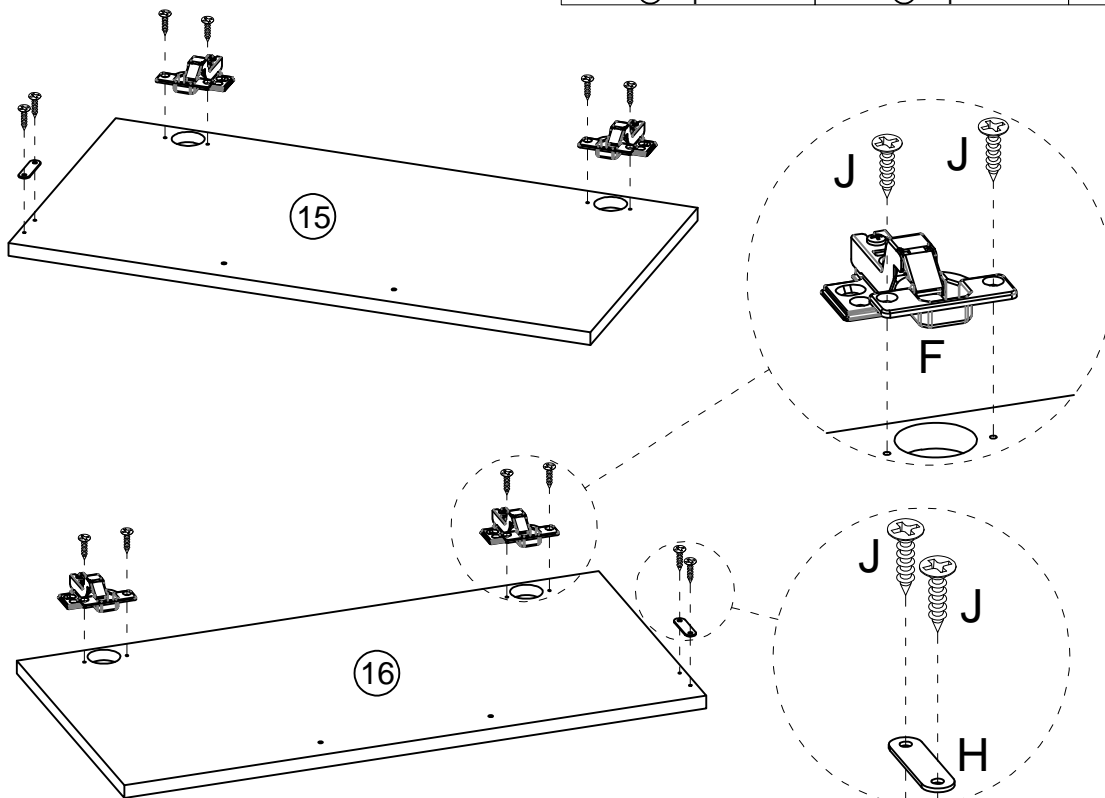

Step 16 Schritt 16

		 3.5×14mm
ⓕ×4pcs	ⓓ×2pcs	ⓐ×12pcs



Step 17

Schritt 17

	 M4×18mm
ⓓ × 2pcs	ⓔ × 4pcs

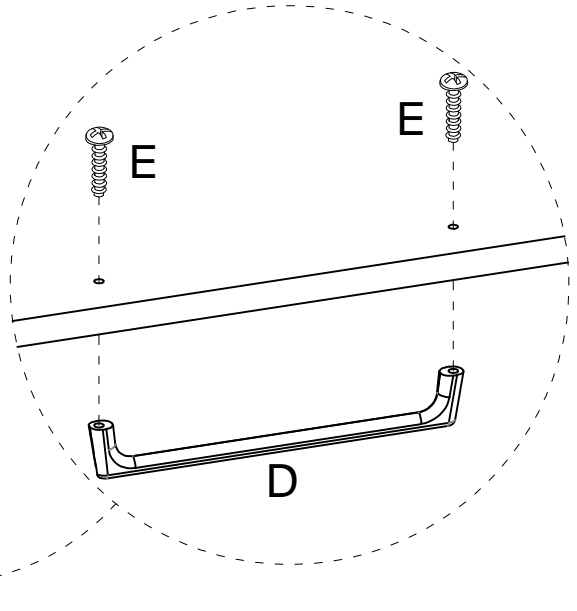
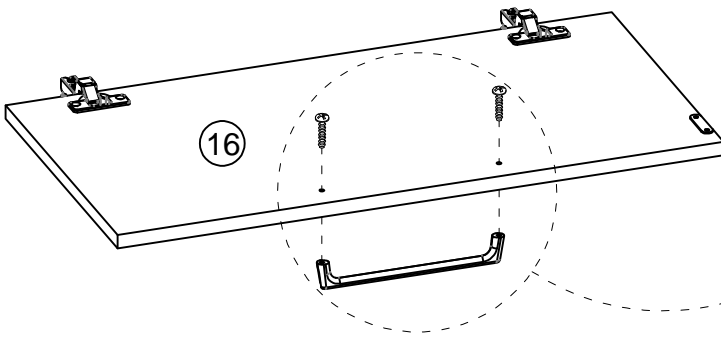
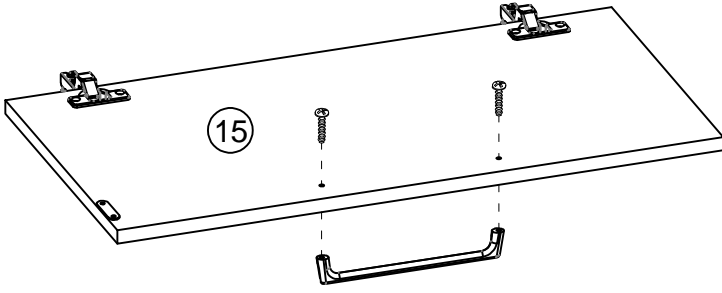

Step 18

Schritt 18

 3.5×14mm
ⓙ × 8pcs

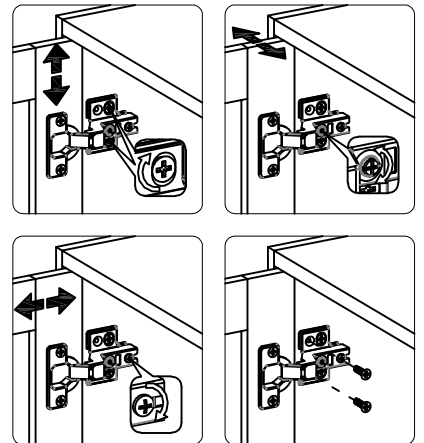
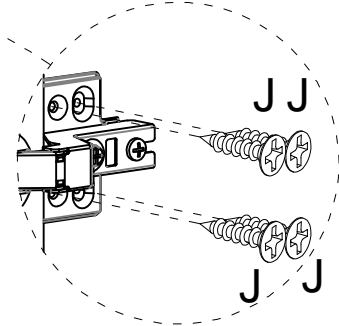
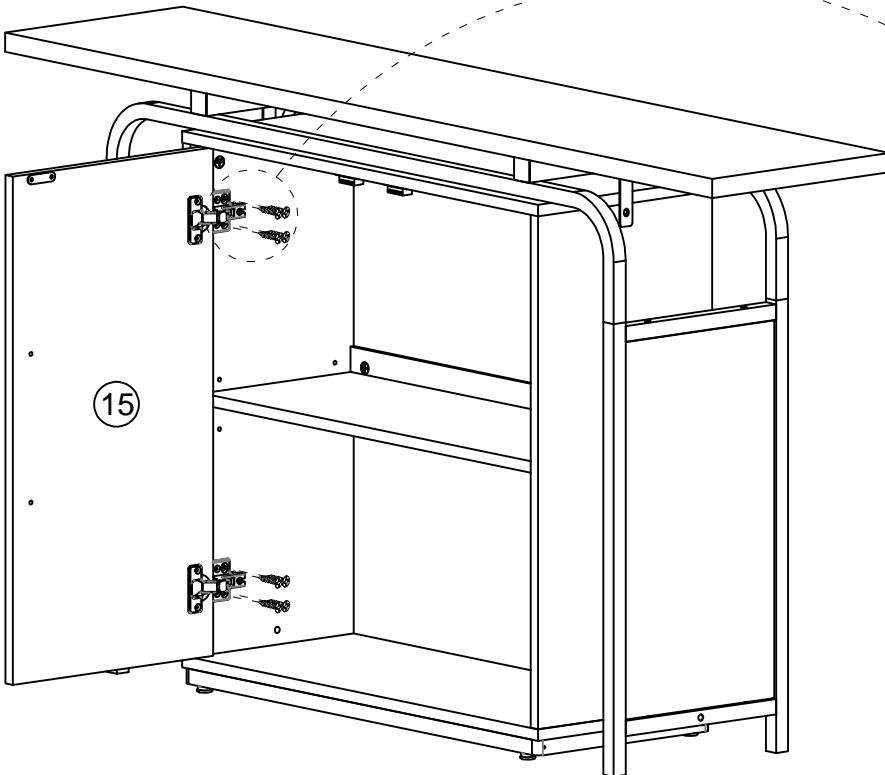

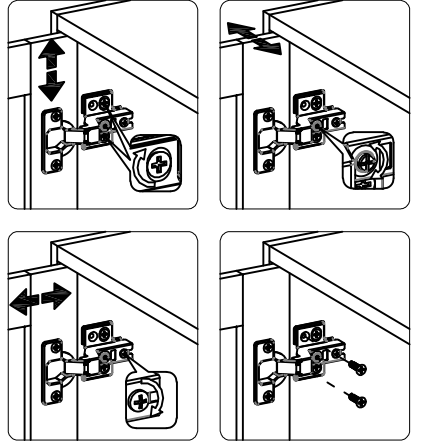
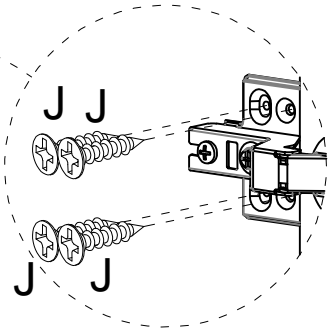
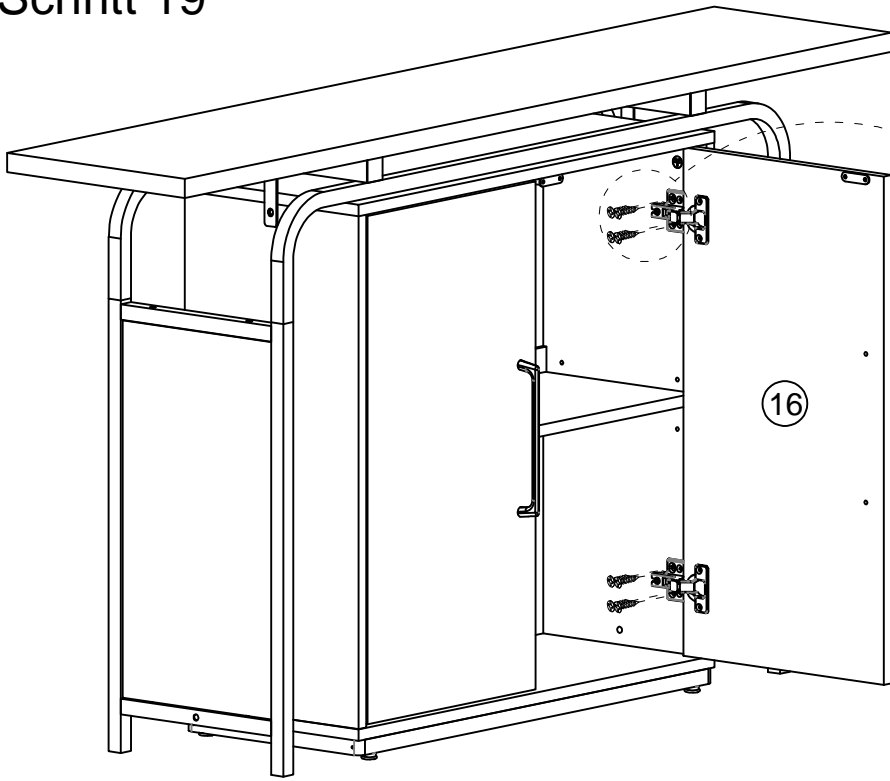

Step 19
Schritt 19

3.5x14mm
Ⓝx8pcs

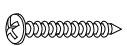

Step 20
Schritt 20

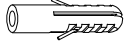
		
4x35mm		
Ⓚx2pcs	Ⓢx2pcs	Ⓣx2pcs

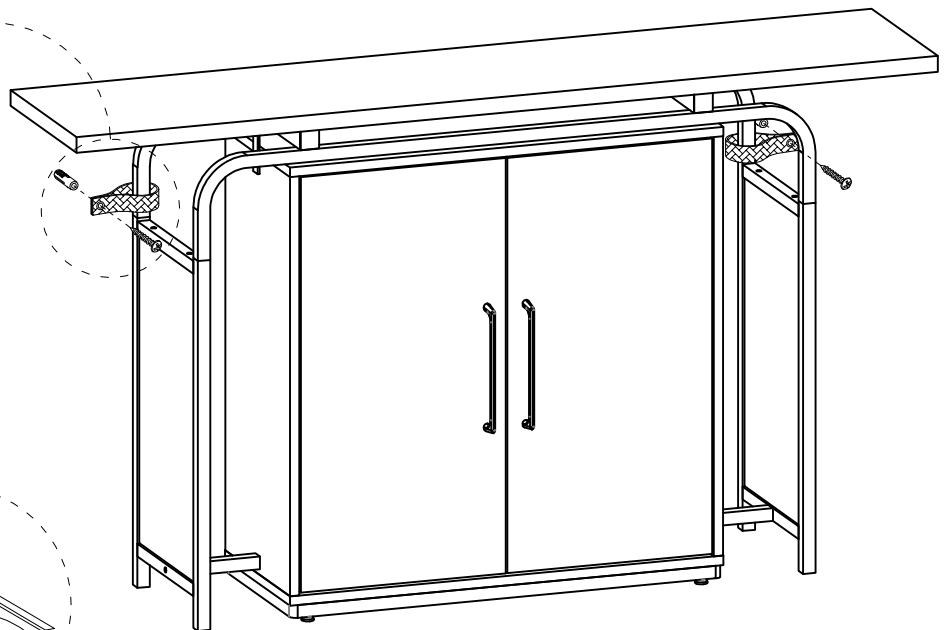
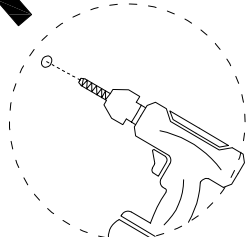
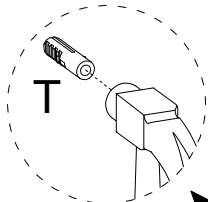
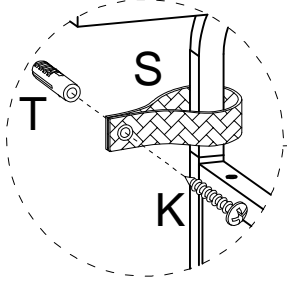



DE

Warnung

1. Die maximale Tragfähigkeit der Produktoberplatte beträgt 60 kg. Überlastung vermeiden.
2. Bitte Kinder nicht auf das Möbel klettern lassen, da dies zu Umkippen und schweren Verletzungen führen kann.
3. Zur Sicherheit bitte die Anweisungen korrekt befolgen und gegebenenfalls professionelle Hilfe in Anspruch nehmen.
4. Das Möbel nicht in der Nähe von Hitzequellen oder heißen Gegenständen platzieren, um Brandgefahr zu vermeiden.
5. Das Möbel nicht in feuchten Umgebungen aufstellen, um Schäden am Material zu vermeiden.
6. Regelmäßige Überprüfung aller Verbindungsstücke und Befestigungen, um sicherzustellen, dass sie fest sitzen und unerwartete Unfälle zu verhindern.
7. Das Produkt ist mit einem Kippschutz ausgestattet, um Verletzungen durch Umkippen zu verhindern.

UK

Warning

- 1 The maximum load-bearing capacity of the product top panel is 60 kg. Do not overload.
- 2 Please do not allow children to climb on furniture, as this may result in tipping and serious injuries.
- 3 For safety, please follow the instructions correctly and seek professional assistance if necessary.
- 4 Do not place furniture near heat sources or hot items to avoid the risk of fire.
- 5 Do not place furniture in damp environments to prevent material damage.
- 6 Regularly check all fittings and fastenings to ensure they are secure and to prevent accidents.
- 7 This product comes with an anti-tip device to prevent injuries from tipping.

FR

Avertissement

- 1 La capacité de charge maximale du plateau supérieur du produit est de 60 kg. Ne pas surcharger.
- 2 Veuillez ne pas laisser les enfants grimper sur les meubles, car cela peut entraîner un basculement et des blessures graves.
- 3 Pour des raisons de sécurité, veuillez suivre correctement les instructions et demander de l'aide professionnelle si nécessaire.
- 4 Ne pas placer les meubles près de sources de chaleur ou d'objets chauds pour éviter tout risque d'incendie.
- 5 Ne pas placer les meubles dans des environnements humides pour éviter les dommages matériels.
- 6 Vérifiez régulièrement tous les raccords et fixations pour vous assurer qu'ils sont bien serrés et pour éviter les accidents.
- 7 Ce produit est équipé d'un dispositif anti-basculement pour éviter les blessures en cas de basculement.

IT

Avviso

- 1 La capacità massima di carico del piano superiore del prodotto è di 60 kg. Non sovraccaricare.
- 2 Si prega di non permettere ai bambini di arrampicarsi sui mobili, poiché ciò potrebbe causare il ribaltamento e gravi lesioni.
- 3 Per motivi di sicurezza, seguire correttamente le istruzioni e richiedere assistenza professionale se necessario.
- 4 Non posizionare i mobili vicino a fonti di calore o oggetti caldi per evitare il rischio di incendio.
- 5 Non posizionare i mobili in ambienti umidi per evitare danni al materiale.
- 6 Controllare regolarmente tutti i raccordi e i fissaggi per assicurarsi che siano saldi e per evitare incidenti.
- 7 Questo prodotto è dotato di un dispositivo anti-ribaltamento per evitare lesioni dovute al ribaltamento.

ES

Aviso

- 1 La capacidad máxima de carga del panel superior del producto es de 60 kg. No sobrecargar.
- 2 Por favor, no permita que los niños trepen sobre los muebles, ya que esto podría provocar que se vuelquen y causar lesiones graves.
- 3 Por seguridad, siga correctamente las instrucciones y solicite ayuda profesional si es necesario.
- 4 No coloque los muebles cerca de fuentes de calor o objetos calientes para evitar el riesgo de incendio.
- 5 No coloque los muebles en entornos húmedos para evitar daños en el material.
- 6 Revise regularmente todas las conexiones y sujeciones para asegurarse de que estén firmes y para evitar accidentes.
- 7 Este producto viene con un dispositivo antivuelco para evitar lesiones por vuelco.