

1 → 2 → 3 ...

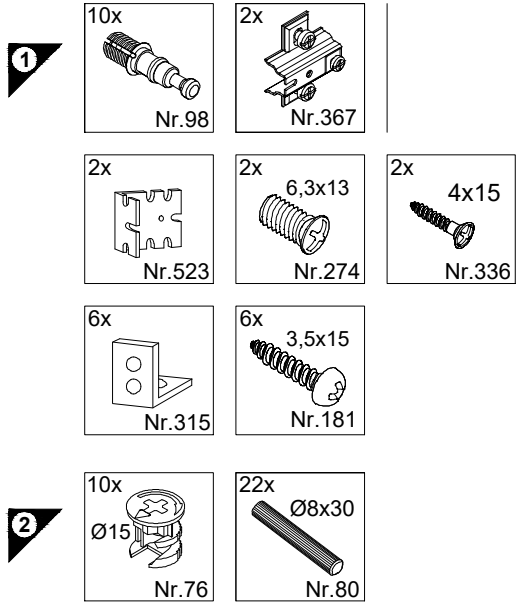

Service-Hotline
01805-678101
0,14€ pro Minute
++49 für Österreich
Auslandstarif pro Minute
service@jaka-bkl.de
voor Nederland en België
00800-40119350
benelux@jaka-bkl.de

*** SFV**
Als Zubehör erhältlich
Available as an accessory
Disponible en accessoire
Verkrijgbaar als accessoire
Se puede obtener como accesorio
Disponibile come accessorio
продаётся как принадлежность
Dostępna jako dodatkowe wyposażenie

Tartozékként kapható
k dodání jako příslušenství
Dobavljivo kot dodatna oprema
Lisävaruste
Kan levereras som tillbehör
Dostupné ako príslušenstvo
Disponibil ca accesoriu
продаётся как принадлежность
Aksesuar olarak temin alınabilir

Montageanleitung

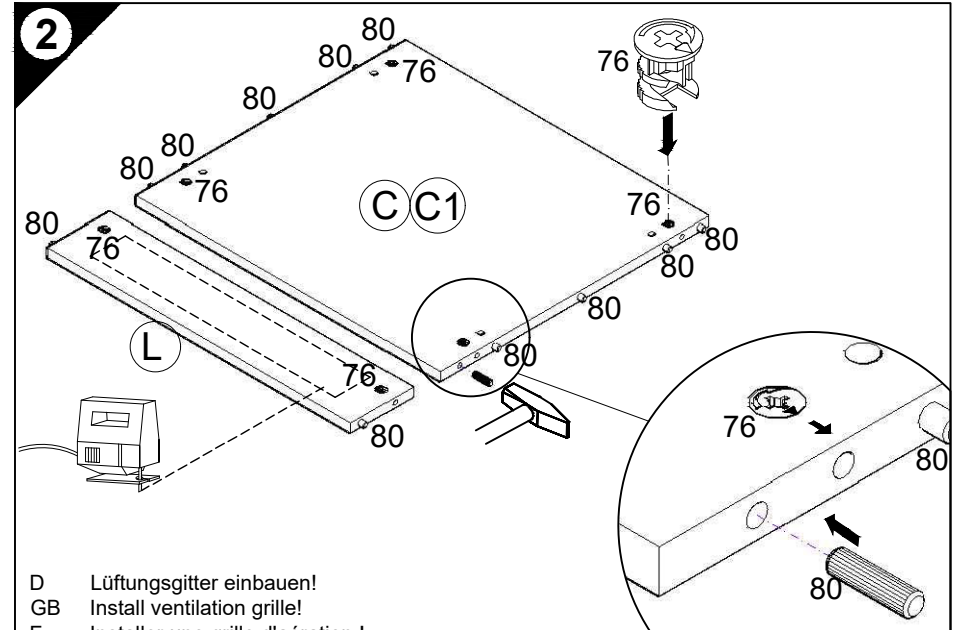
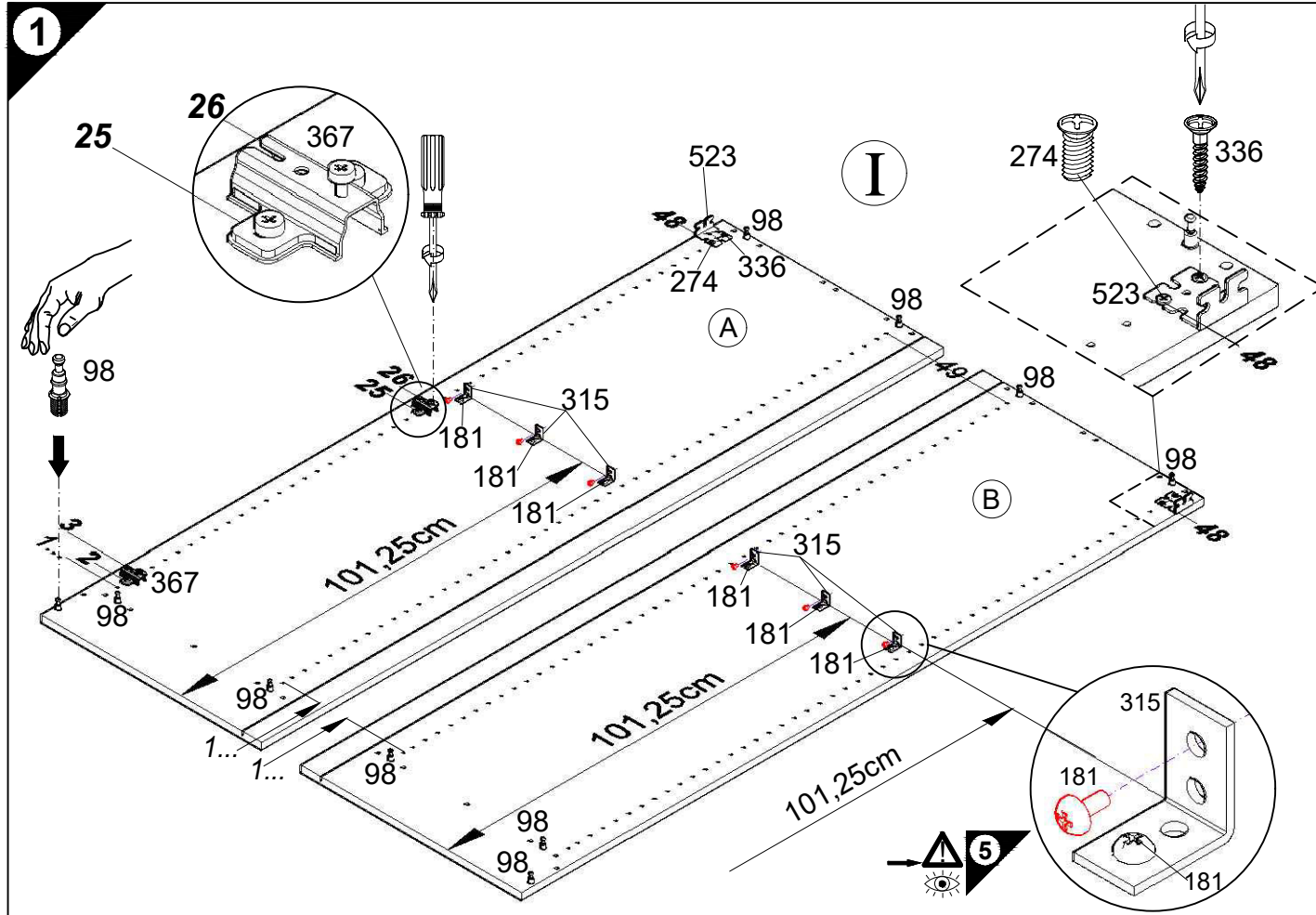
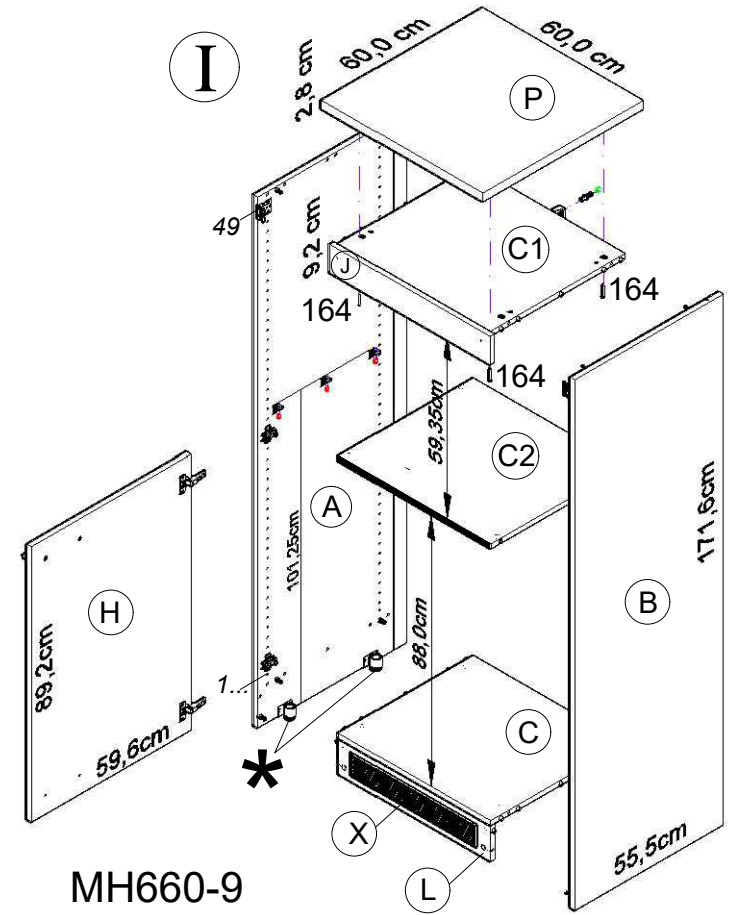
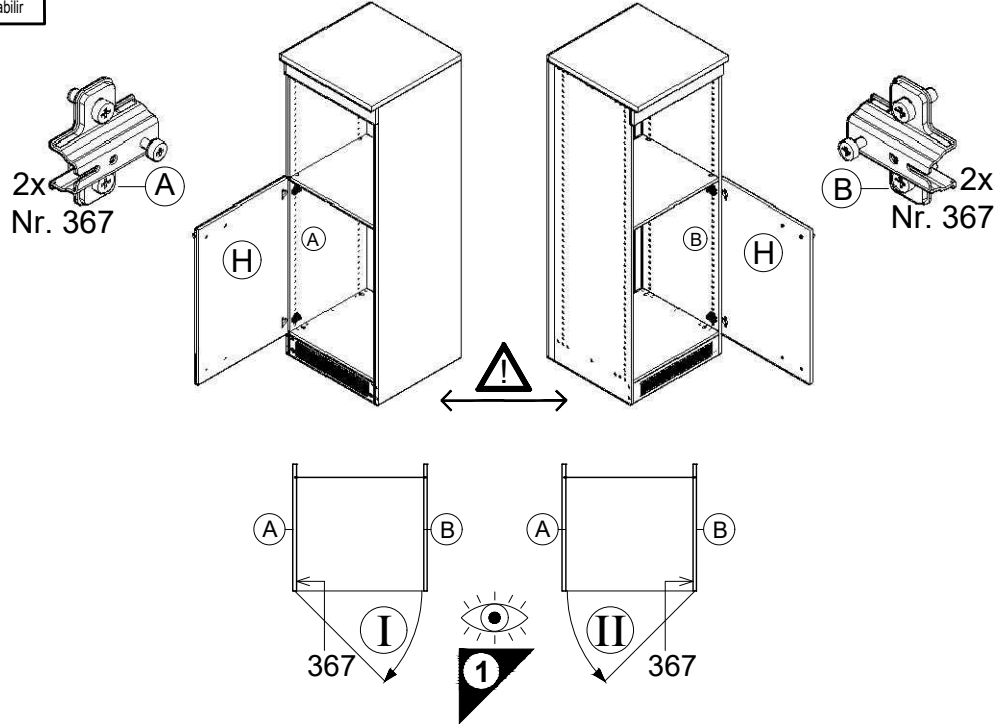
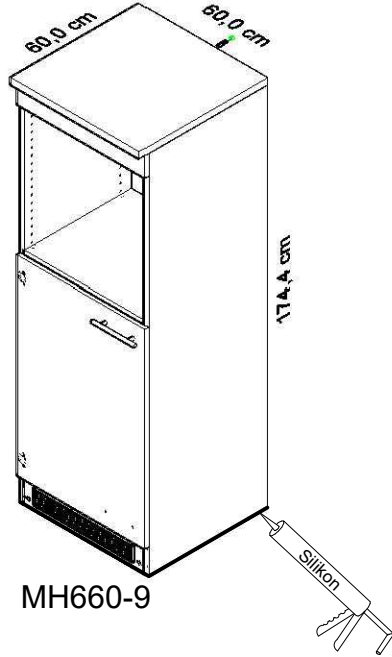

- D Lüftungsgitter einbauen!
- GB Install ventilation grille!
- F Installer une grille d'aération !
- NL Luchtrooster inbouwen!
- E ¡Montar la rejilla de ventilación!
- I Montare la griglia di aerazione!
- RUS Встроить вентиляционную решетку!
- PL Zamontować kratkę wentylacyjną!
- H Építse be a szellőzőrácsot!
- CZ Zamontujte větrací mřížku
- SLO Potrebna je vgradnja prezračevalne rešetke!
- FIN Asenna tuuletusrätkä!
- S Montera luftningsgallret!
- SK Namontujte vetraciu mriežku!
- RO Montați grilajul de aerisire!
- TR Havalandırma izgarasını takın!

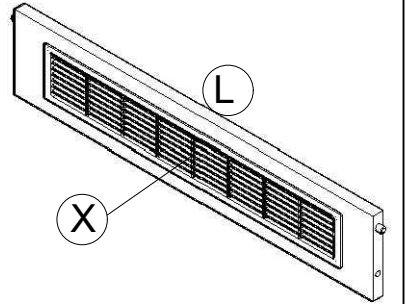

1 → 2 → 3 ...

- 4 2x 6,3x13
Nr.274
- 5 6x 3,5x15
Nr.181
- 6 3x 4x30
Nr.424
- 7 1x Nr.214 2x 4,5x15
Nr.191
- 1x Ø8 1x 4,5x45
Nr.70 Nr.175
- 9 2x
Nr.365
- 10 4x 4x30
Nr.164

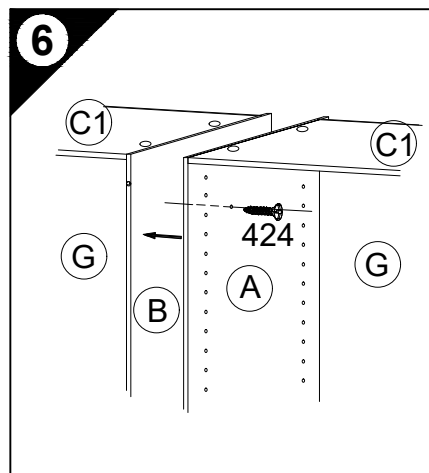
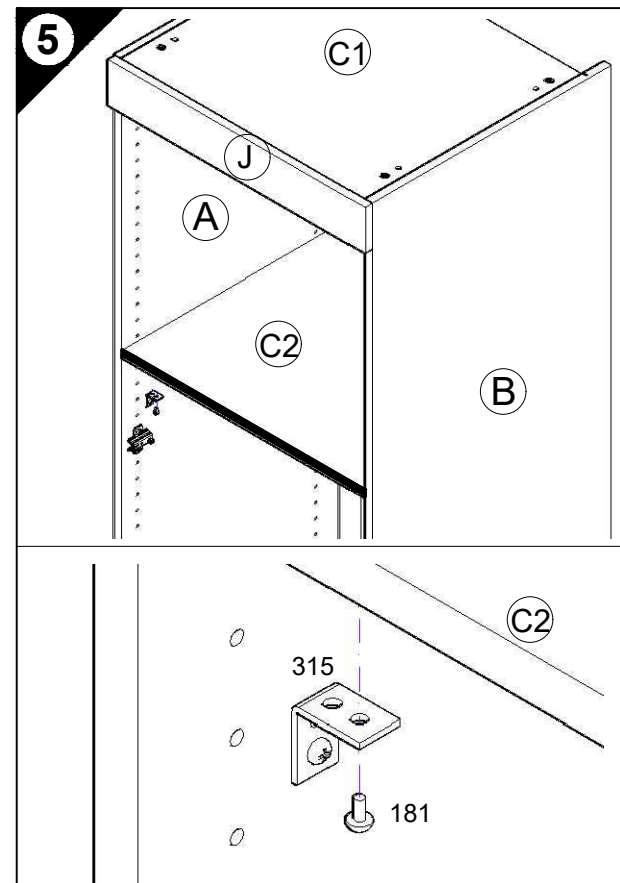
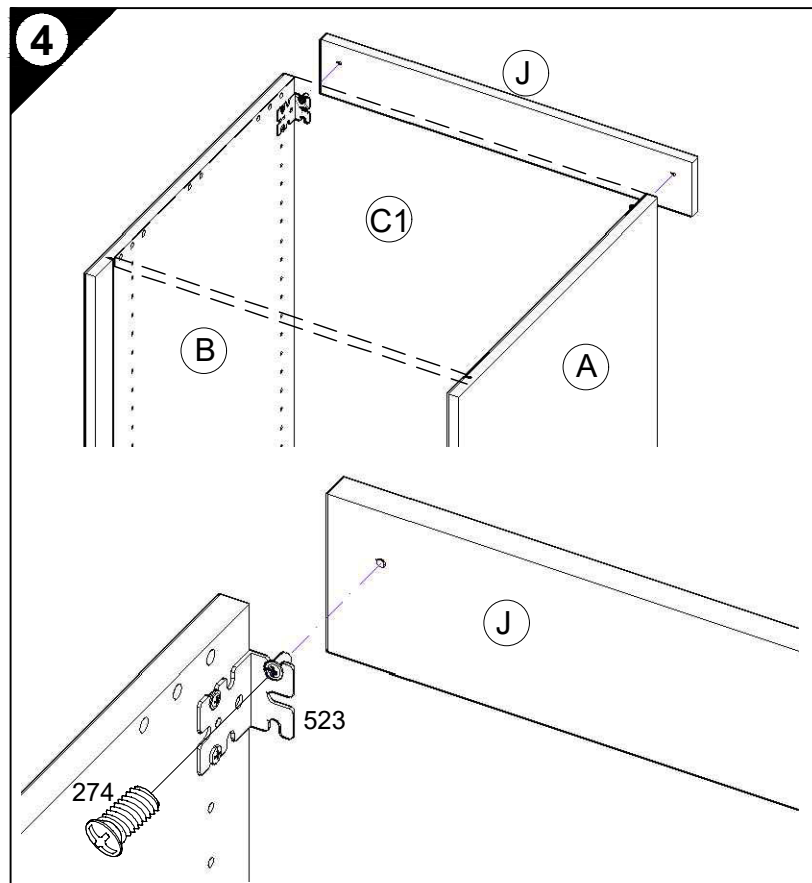
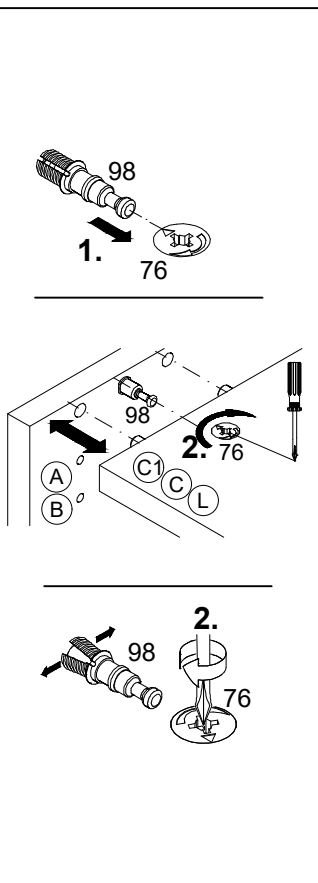
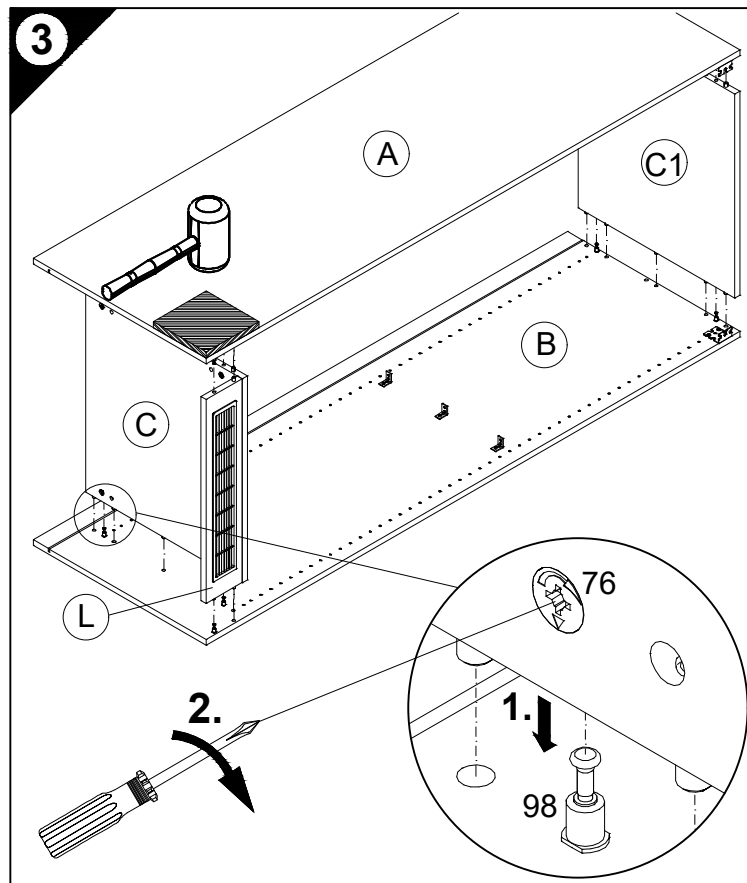

7

D Wandbefestigung zwingend erforderlich!
 GB Wall fixing essential!
 F A fixer impérativement au mur!
 NL Wandbevestiging dringend vereist!
 E ¡Fijación en la pared absolutamente necesaria!
 I Il fissaggio alla parete è indispensabile!
 RUS Крепление к стене обязательно!
 PL Mocowanie do sciany bezwzględnie konieczne!
 H A falra történő rögzítésre feltétlenül szükség van!
 CZ Nástěnná montáž nezbytně nutná!
 SLO Obvezna je pritrditev na steno!
 FIN Kiinnitettävä ehdottomasti seinään!
 S Ett väggfäste är absolut nödvändigt!
 SK Nutná montáž na stenu!
 RO Fixarea la perete este neapărat necesară!
 TR Duvara sabitlenmesi kesinlikle gerekir!

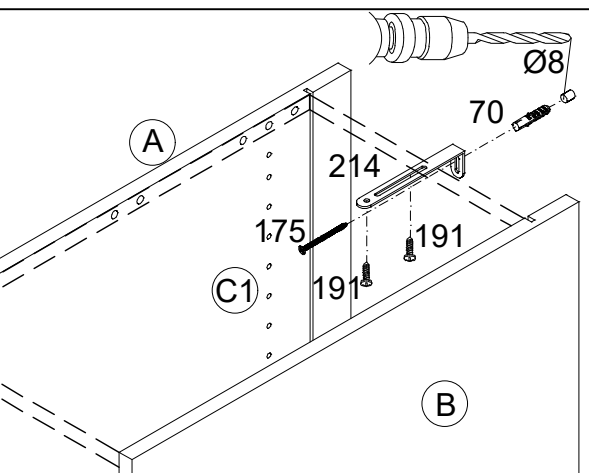

D Untergrund und Befestigungsmittel auf Eignung prüfen!
 GB Check substructure and fixings for suitability!
 F Contrôler si le support et les moyens de fixation sont bien adéquats !
 NL Ondergrond en bevestigingsmateriaal op functionaliteit controleren!
 E ¡Comprobar el suelo y los medios de fijación en cuanto a su aptitud!
 I Controllare l'idoneità del fondo e del materiale di fissaggio!
 RUS Основание и крепежный материал проверить на пригодность!
 PL Podłoże oraz materiały do zamocowania sprawdzić na ich przydatność!
 H Az alapelületet és a rögzítő anyagokat megfelelőség szempontjából ellenőrizni kell!
 CZ Přezkoušejte podklad a vhodnost upevňovacích prostředků!
 SLO Preverite, če se ujemajo spodnja stran in pritrdilna sredstva!
 FIN Tarkista alustan ja kiinnitysvälineiden sopivuus!
 S Kontrollera att underlaget och fästmedlen är lämpliga!
 SK Preverte vhodnosť podkladu a upevňovacích prostriedkov!
 RO Verificați caracterul adecvat al suprafeței suport și al mijloacelor de fixare!
 TR Zeminin ve bağlanı elemanlarının uygunluğunu kontrol edin!

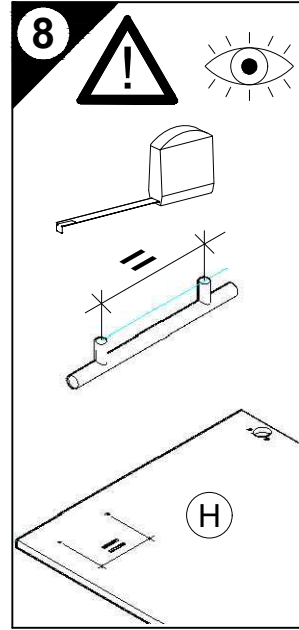

8

D Holzunterlage verwenden!
 Front andrücken, scharfen Bohrer verwenden und mit wenig Druck durchbohren!
 GB Use a wooden base!
 Press front down, use sharp drill bit and, by applying slight pressure, drill a hole
 F Utiliser un support en bois !
 Appuyer sur la façade, utiliser un foret bien affûté et percer en appliquant une faible pression !
 NL Houten onderlegger gebruiken!
 Druk het front aan, gebruik een scherpe boor en oefen bij het boren weinig druk uit!
 E ¡Utilizar una base de madera!
 ¡Presionar el frente, utilizar una broca afilada y taladrar con poca presión!
 I Utilizzare una base di legno! Appoggiare la facciata, utilizzare una punta di trapano affilata e trapanare esercitando solo una leggera pressione!
 RUS Использовать деревянную подложку!
 Прижать фасад, использовать острое сверло и просверлить с незначительным давлением!
 PL Używać podkładkę z drewna!
 Docisnąć front, użyć ostrego wiertła i przewiercić, używając małej siły nacisku!



H Alkalmazzon fa alátétet!
 Nyomja le az előlapot, használjon éles fűrőt, és kis nyomással fúrja át!
 CZ Použijte dřevěný podklad!
 Přitlačte čelo, použijte ostrý vrták a provrťte pomocí malého tlaku!
 SLO Uporabite leseno podlago!
 Pritisnite ličnico ter z ostrim svedrom in z majhnim pritiskom izvrťajte luknjo!
 FIN Käytä puualustaa!
 Paina etulevy paikoilleen, käytä terävää poranterää ja poraa reikä vain kevyesti painamalla!
 S Tryck fronten mot underlaget, använd vass borr och borra igenom med ett lätt tryck!
 SK Použite drevený podklad!
 Pritlačte front, použite ostrý vrták a prevrťajte miernym tlakom!
 RO suport de lemn! Împingeți frontul, utilizați un burghiu ascuțit și perforați exercitând doar o presiune redusă!
 TR Ahşap taban kullanın!
 Önden bastırın, keskin matkap ucu kullanın ve az basınç uygulayarak delin!

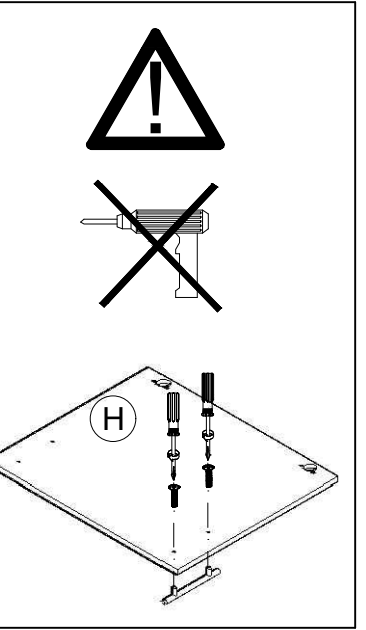

H

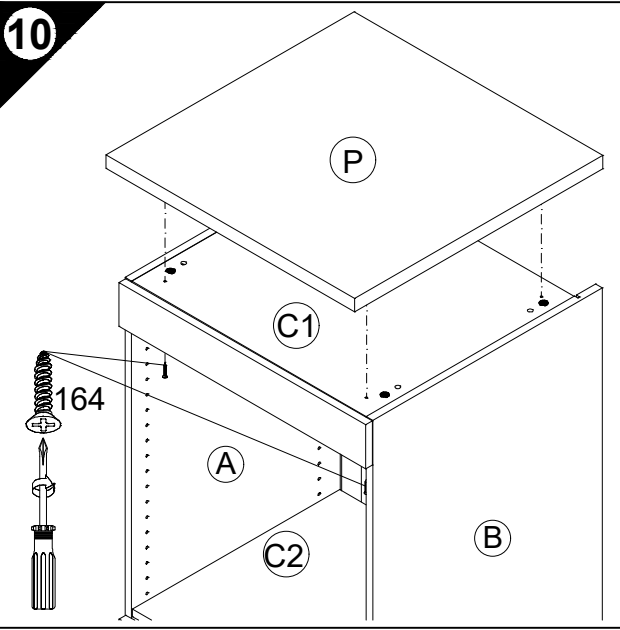
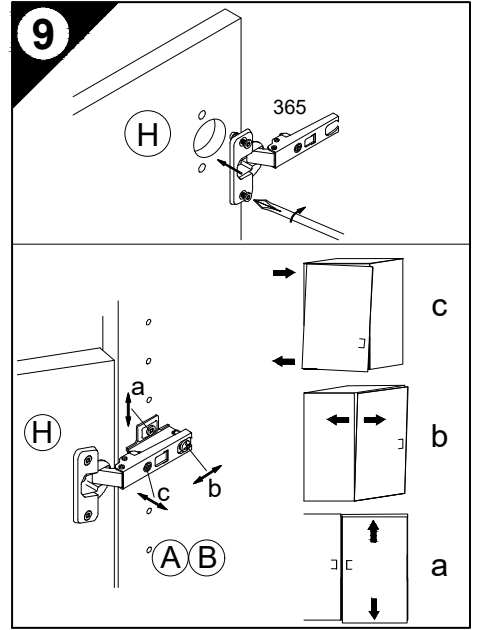

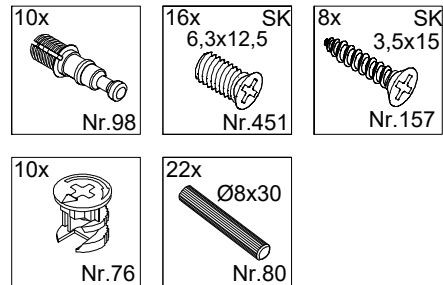
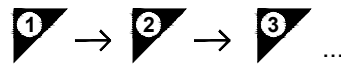
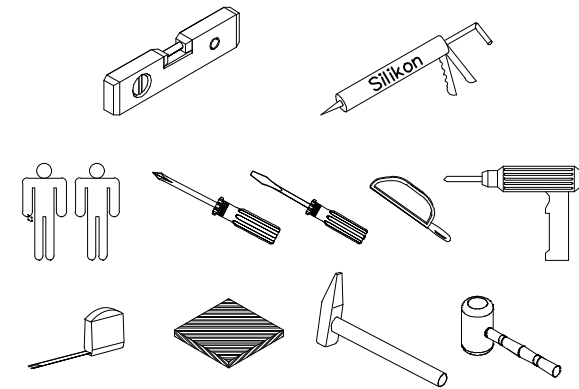

Montageanleitung

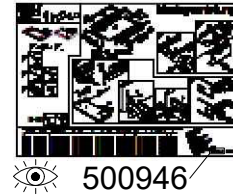
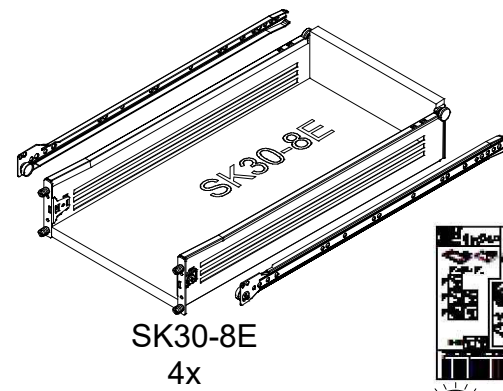
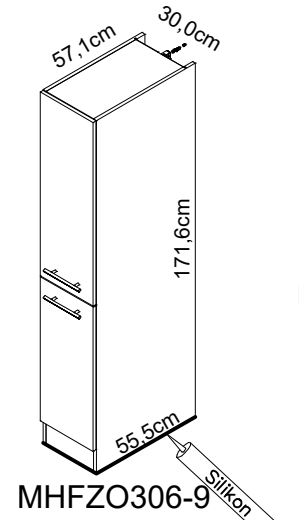
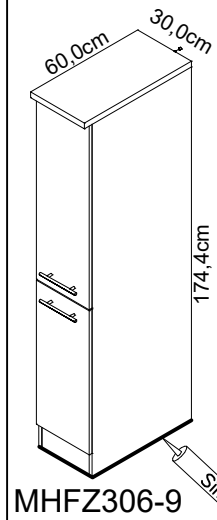

*** SFV**

Als Zubehör erhältlich
Available as an accessory
Disponible en accessoire
Verkrijgbaar als accessoire
Se puede obtener como accesorio
Disponibile come accessorio
продаётся как принадлежность
Dostępna jako dodatkowe wyposażenie
Tartozéként kapható
k dodání jako příslušenství
Dobavljivo kot dodatna oprema
Lisavaruste
Kan levereras som tillbehör
Dostupné ako príslušenstvo
Disponibil ca accesoriu
Aksesuar olarak temin alınabilir

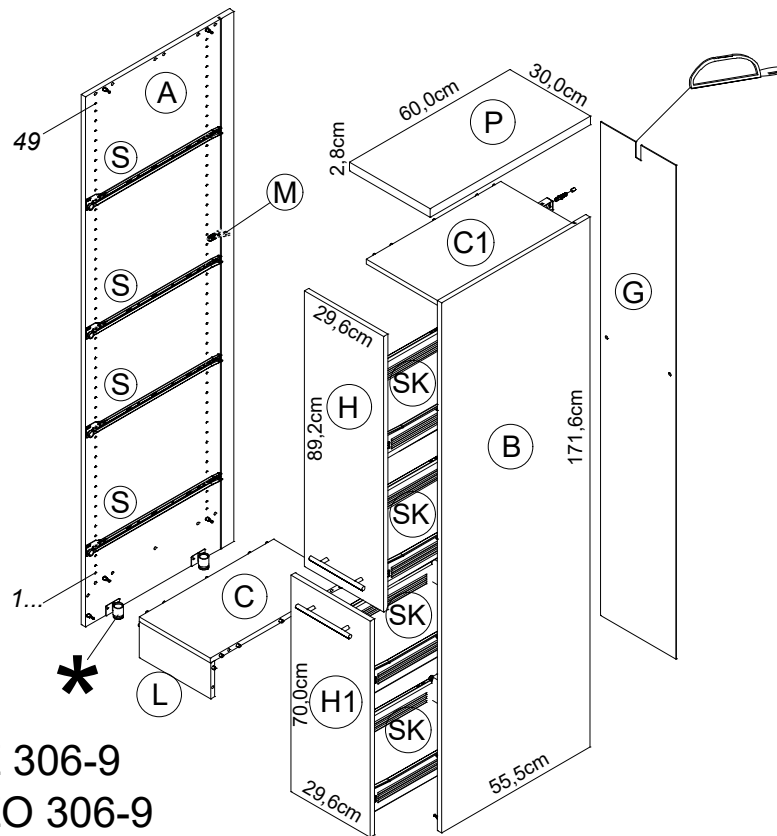

MHFZ 306-9
MHFZO 306-9

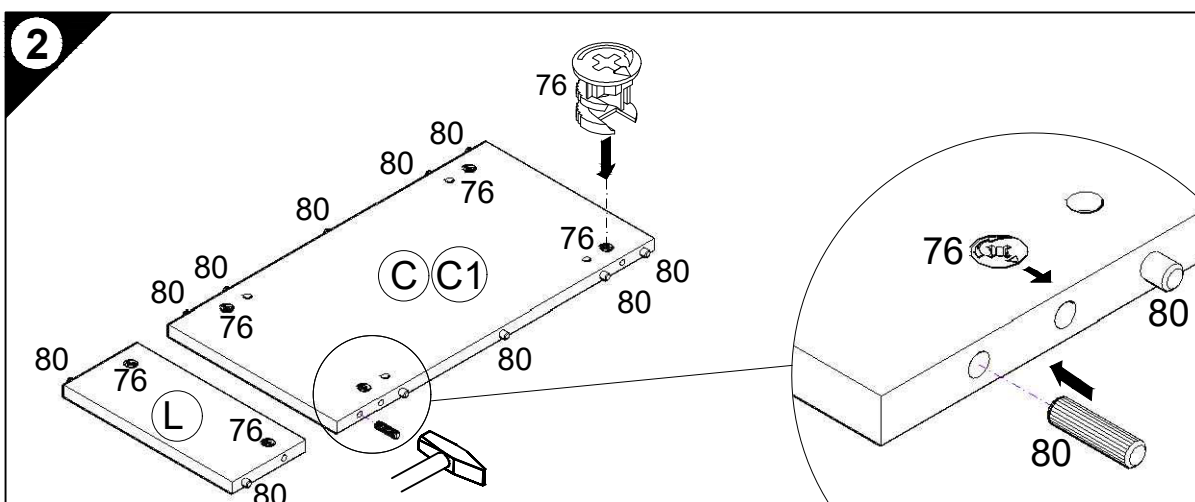
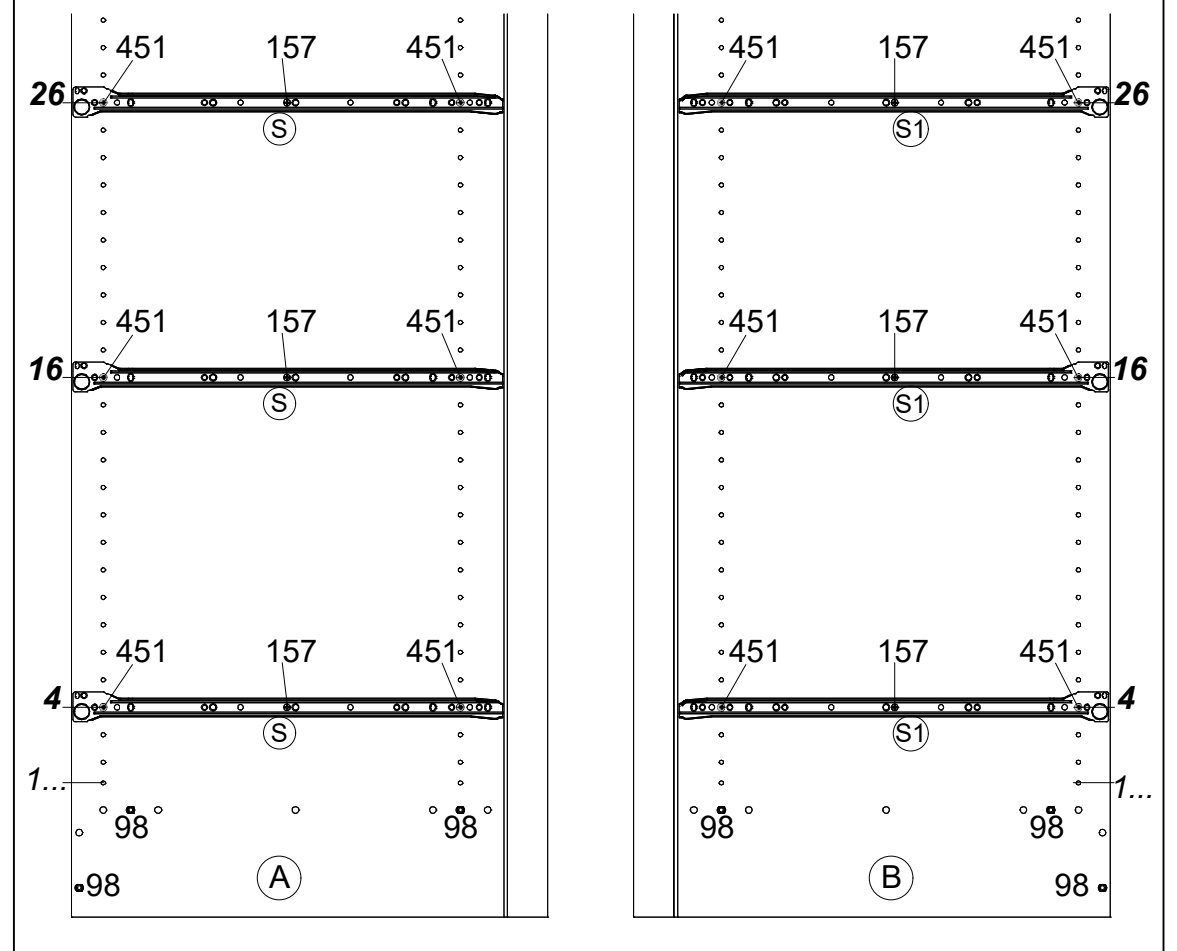
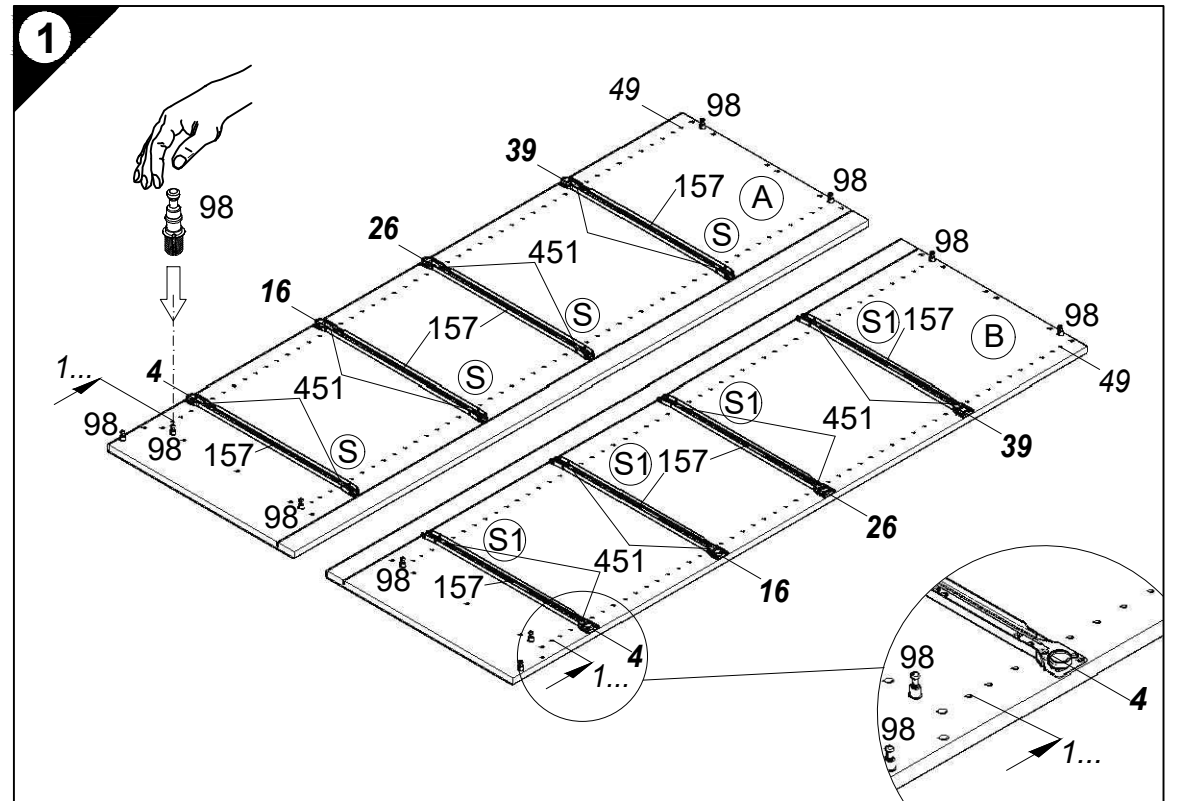

Service-Hotline
01805-678101
0,14€ pro Minute
++49 für Österreich
Auslandstarif pro Minute
service@jaka-bkl.de
voor Nederland en België
00800-40119350
benelux@jaka-bkl.de

1 → 2 → 3 ...

- 5 10x 1,4x25 Nr.204
- 6 2x 948136 Nr.540 2x 948136 4x17 Nr.196
- 2x 948136 3,5x20 Nr.412
- 7 3x 4x30 Nr.424
- 8 1x 4x30 Nr.214 2x 4,5x15 Nr.191
- 1x Ø8 Nr.70 1x 4,5x45 Nr.175
- 10 4x 4x30 Nr.164

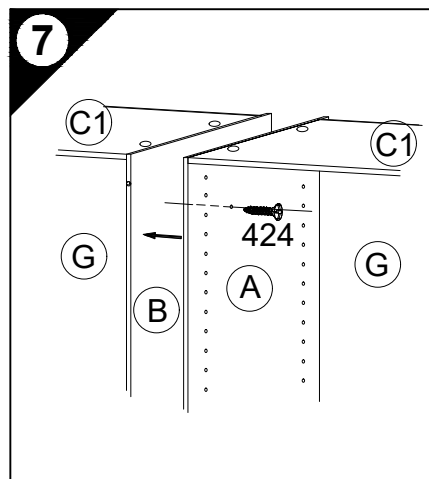
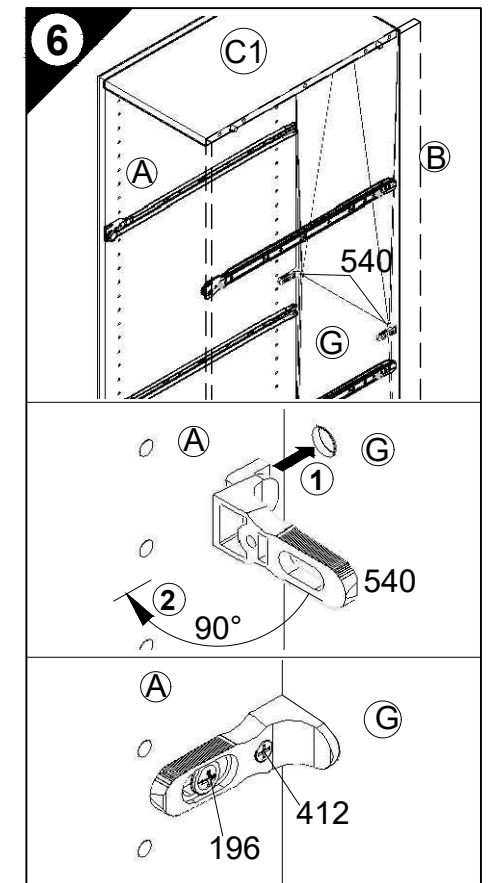
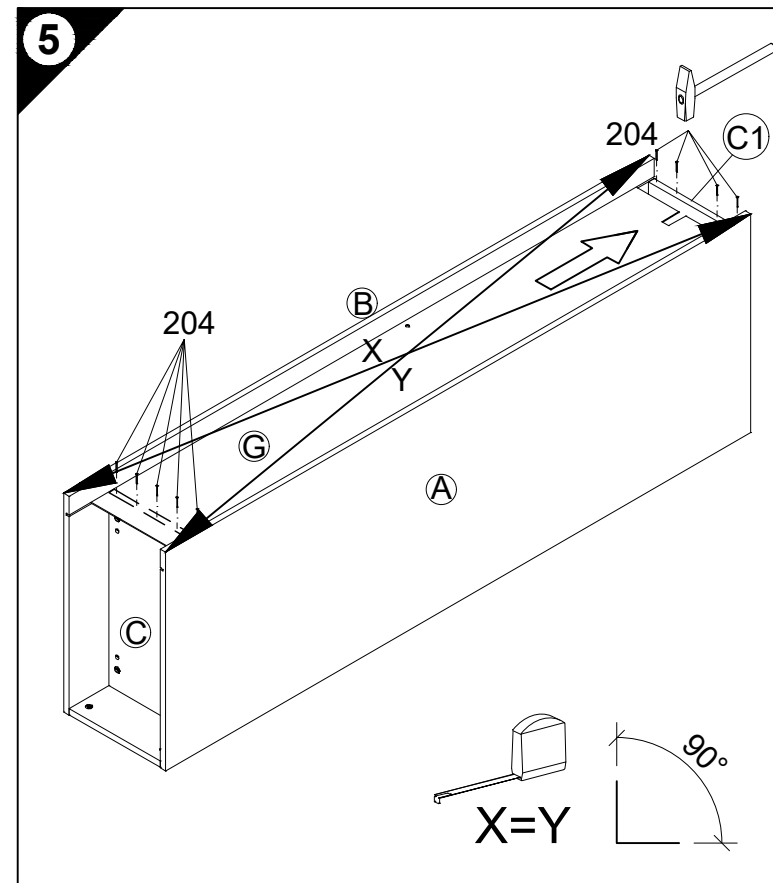
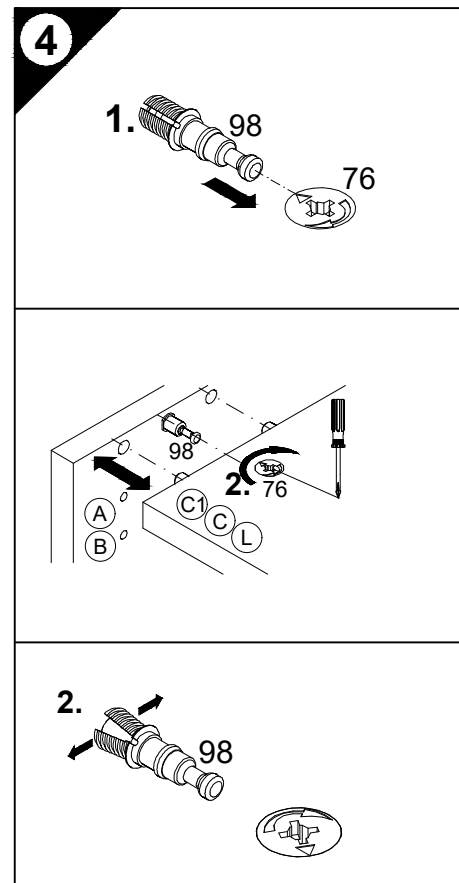
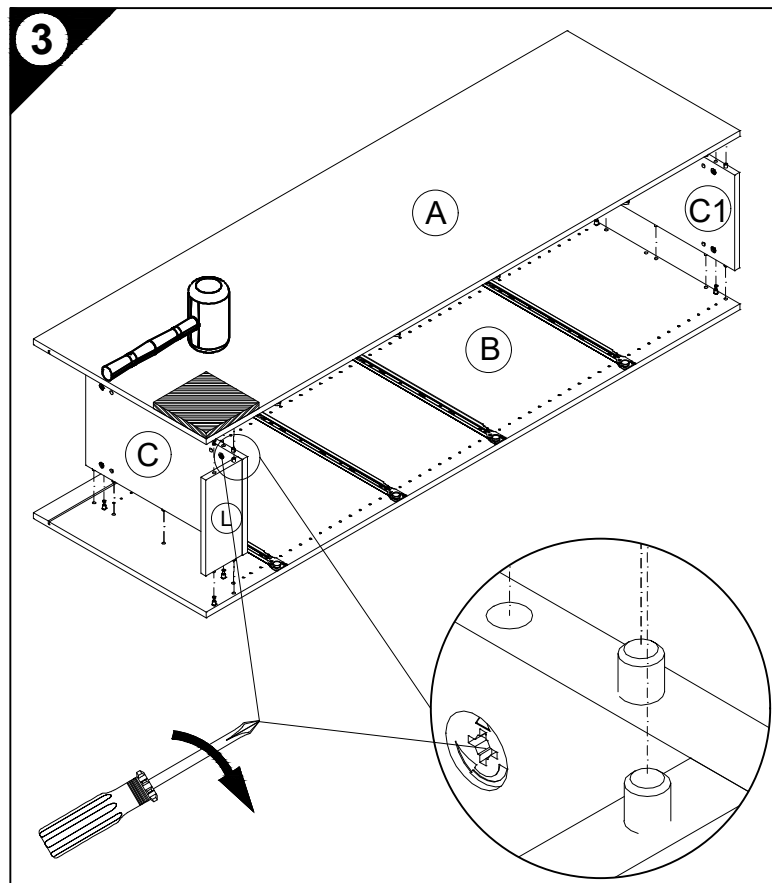

- 8**
- D Wandbefestigung zwingend erforderlich!
 - GB Wall fixing essential!
 - F A fixer impérativement au mur!
 - NL Wandbevestiging dringend vereist!
 - E ¡Fijación en la pared absolutamente necesaria!
 - I Il fissaggio alla parete è indispensabile!
 - RUS Крепление к стене обязательно!
 - PL Mocowanie do ściany bezwzględnie konieczne!
 - H A falra történő rögzítésre feltétlenül szükség van!
 - CZ Nástěnná montáž nezbytně nutná!
 - SLO Obvezna je pritrditev na steno!
 - FIN Kiinnitettävä ehdottomasti seinään!
 - S Ett väggfäste är absolut nödvändigt!
 - SK Nutná montáž na stenu!
 - RO Fixarea la perete este neapărat necesară!
 - TR Duvara sabitlenmesi kesinlikle gerekir!

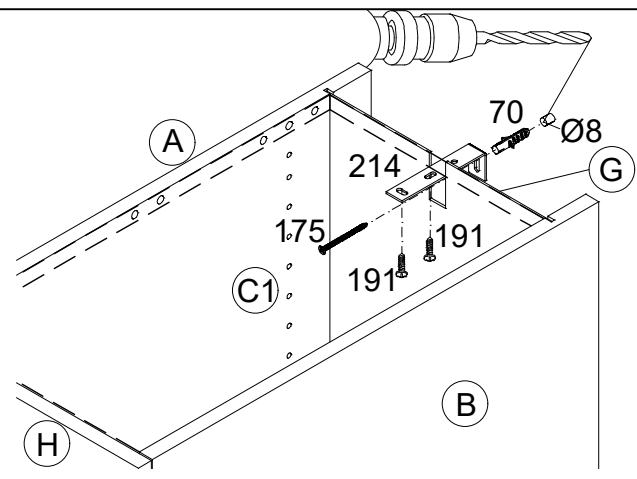

- D Untergrund und Befestigungsmittel auf Eignung prüfen!
- GB Check substructure and fixings for suitability!
- F Contrôler si le support et les moyens de fixation sont bien adéquats !
- NL Ondergrond en bevestigingsmateriaal op functionaliteit controleren!
- E ¡Comprobar el suelo y los medios de fijación en cuanto a su aptitud!
- I Controllare l'idoneità del fondo e del materiale di fissaggio!
- RUS Основание и крепежный материал проверить на пригодность!
- PL Podłoże oraz materiały do zamocowania sprawdzić na ich przydatność!
- H Az alapfelületet és a rögzítő anyagokat megfelelőség szempontjából ellenőrizni kell!
- CZ Přezkoušejte podklad a vhodnost upevňovacích prostředků!
- SLO Preverite, če se ujemajo spodnja stran in pritrdilna sredstva!
- FIN Tarkista alustan ja kiinnitysvälineiden sopivuus!
- S Kontrollera att underlaget och fästmedlen är lämpliga!
- SK Preverte vhodnosť podkladu a upevňovacích prostriedkov!
- RO Verificați caracterul adecvat al suprafeței suport și al mijloacelor de fixare!
- TR Zemin ve bağlanı elemanlarının uygunluğunu kontrol edin!

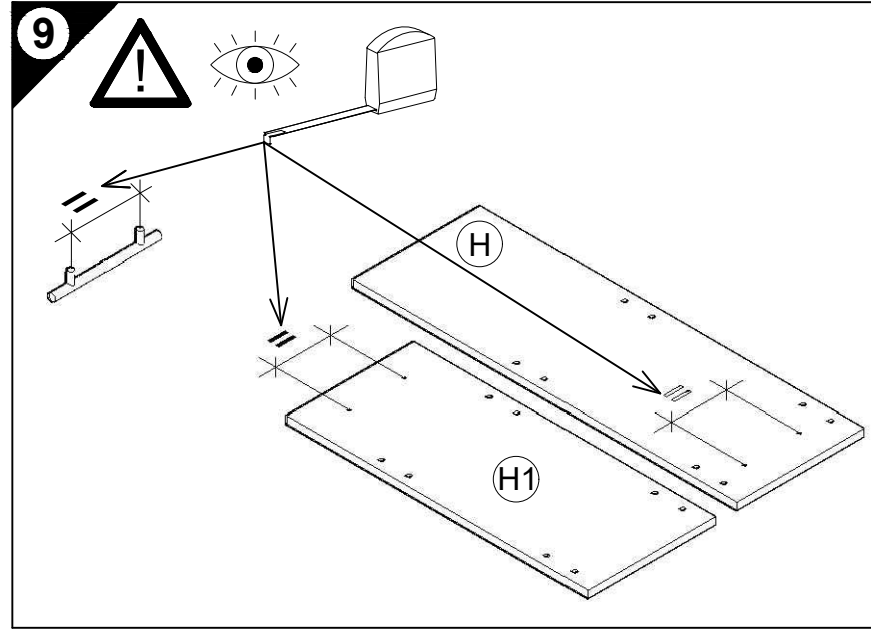

- 9**
- D Holzunterlage verwenden!
Front andrücken, scharfen Bohrer verwenden und mit wenig Druck durchbohren!
 - GB Use a wooden base!
Press front down, use sharp drill bit and, by applying slight pressure, drill a hole
 - F Utiliser un support en bois !
Appuyer sur la façade, utiliser un foret bien affûté et percer en appliquant une faible pression !
 - NL Houten onderlegger gebruiken!
Druk het front aan, gebruik een scherpe boor en oefen bij het boren weinig druk uit!
 - E ¡Utilizar una base de madera!
¡Presionar el frente, utilizar una broca afilada y taladrar con poca presión!
 - I Utilizzare una base di legno! Appoggiare la facciata, utilizzare una punta di trapano affilata e trapanare esercitando solo una leggera pressione!
 - RUS Использовать деревянную подложку!
Прижать фасад, использовать острое сверло и просверлить с незначительным давлением!
 - PL Używać podkładkę z drewna!
Docisnąć front, użyć ostrego wiertła i przewiercić, używając małej siły nacisku!

- H Alkalmazzon fa alátétet!
Nyomja le az előlapot, használjon éles fúrót, és kis nyomással fúrja át!
- CZ Použijte dřevěný podklad!
Přitlačte čelo, použijte ostrý vrták a provřtejte pomocí malého tlaku!
- SLO Uporabite leseno podlago!
Pritisnite ličnico ter z ostrim svedom in z majhnim pritiskom izvrtajte luknjo!
- FIN Käytä puualustaa!
Paina etulevy paikoilleen, käytä terävää poranterää ja poraa reikä vain kevyesti painamalla!
- S Använd ett träunderlag!
Tryck fronten mot underlaget, använd vass borr och borra igenom med ett lätt tryck!
- SK Použite drevený podklad!
Přitlačte front, použite ostrý vrták a prevřtajte miernym tlakom!
- RO suport de lemn! Împingeți frontul, utilizați un burghiu ascuțit și perforați exercitând doar o presiune redusă!
- TR Ahşap taban kullanın!
Önden bastırın, keskin matkap ucu kullanın ve az basınç uygulayarak delin!

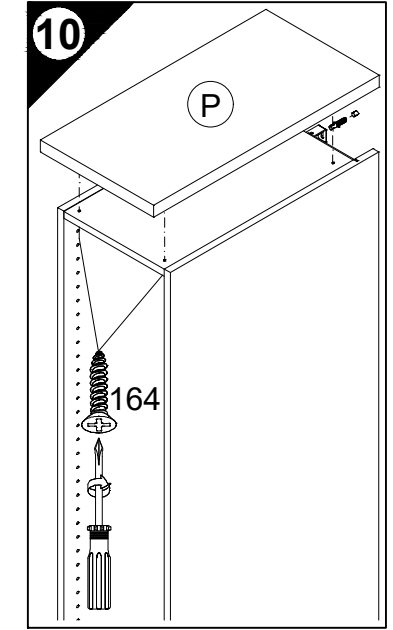
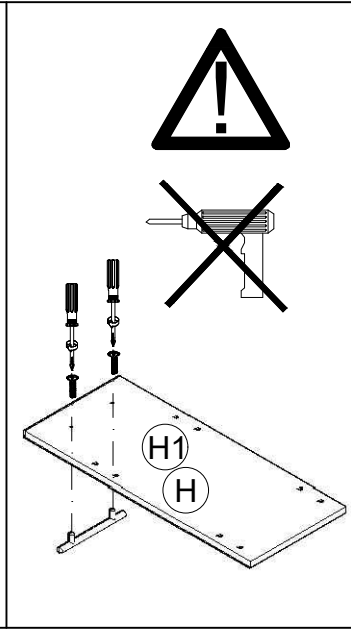

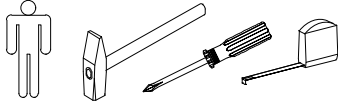

Montageanleitung

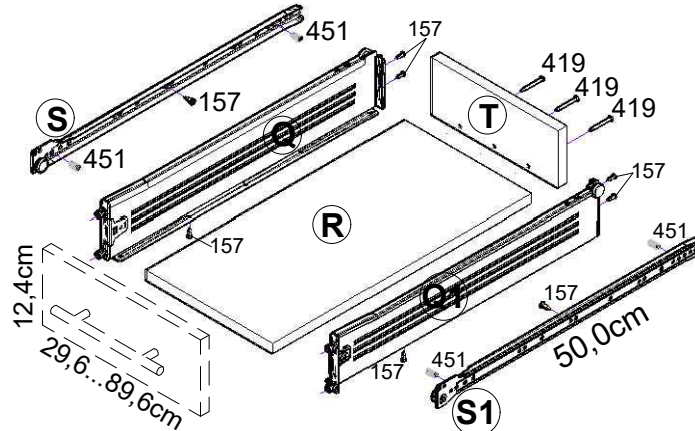
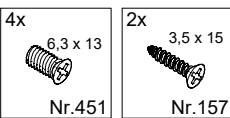
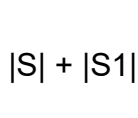
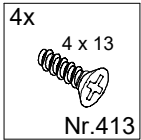
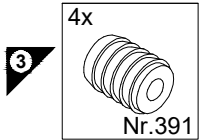
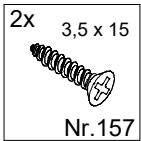
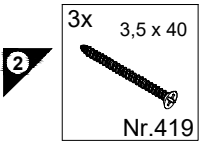
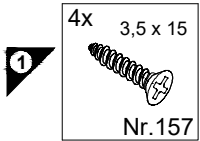
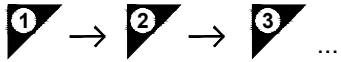
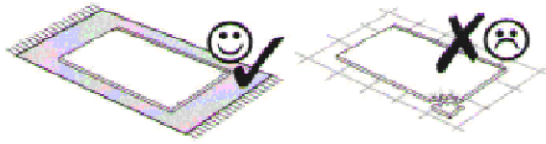

SK30-8E... SK90-8E
(SK30-H... SK90-H)

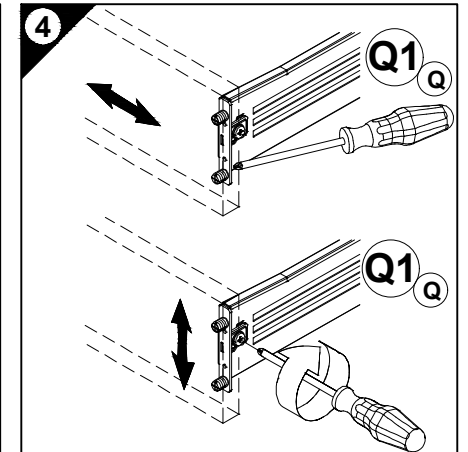
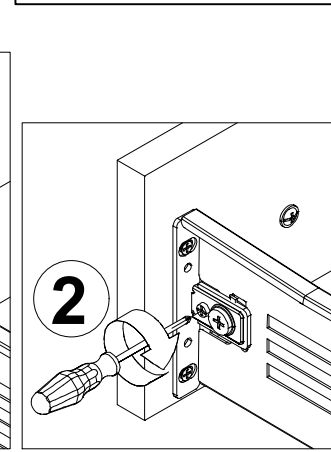
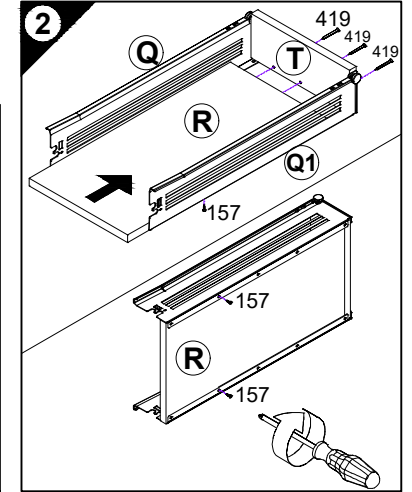
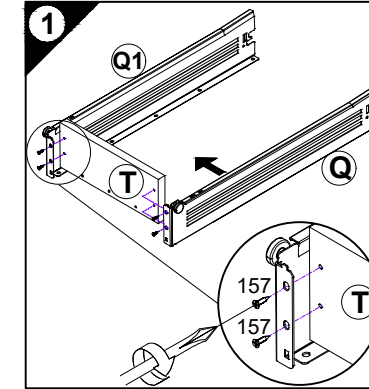
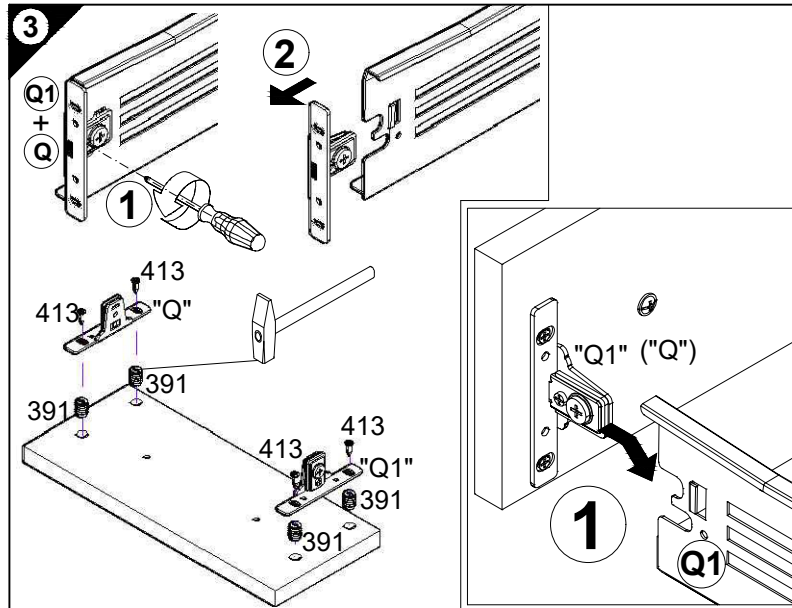

Ersatzteile/Spare parts/pièces de rechange/Reserveonderdelen/Piezas de recambio/Ricambi/Запасные части/Części zamienne/półtaktrészek/Náhradní části/Nadomestni deli/varaosat/reservdelar/náhradné diely/Utilizați piese de schimb/Yedek parçalar

30cm	SK30-8E	Q E966001	Q1 E966002	R E941951	S E966003	S1 E966004	T E941941
40cm	SK40-8E	Q E966001	Q1 E966002	R E941952	S E966003	S1 E966004	T E941942
50cm	SK50-8E	Q E966001	Q1 E966002	R E941953	S E966003	S1 E966004	T E941943
60cm	SK60-8E	Q E966001	Q1 E966002	R E941954	S E966003	S1 E966004	T E941944
90cm	SK90-8E	Q E966001	Q1 E966002	R E941955	S E966003	S1 E966004	T E941945

Service-Hotline
01805-678101
0,14€ pro Min.
+49 für Österreich
Auslandstarif pro Min.
service@jaka-bkl.de
voor Nederland en België
00800-4019350
benelux@jaka-bkl.de

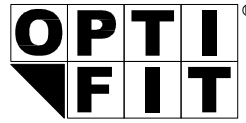

JAKA-BKL GmbH
Jaka Straße 3
D-32351 Sternweide-Wehden

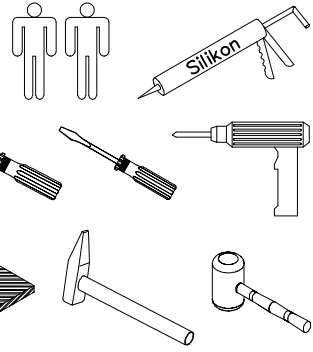

Service-Hotline
01805-678101
0,14€ pro Minute
++49 für Österreich
Auslandstarif pro Minute
service@jaka-bkl.de
voor Nederland en België
00800-40119350
benelux@jaka-bkl.de

Montageanleitung

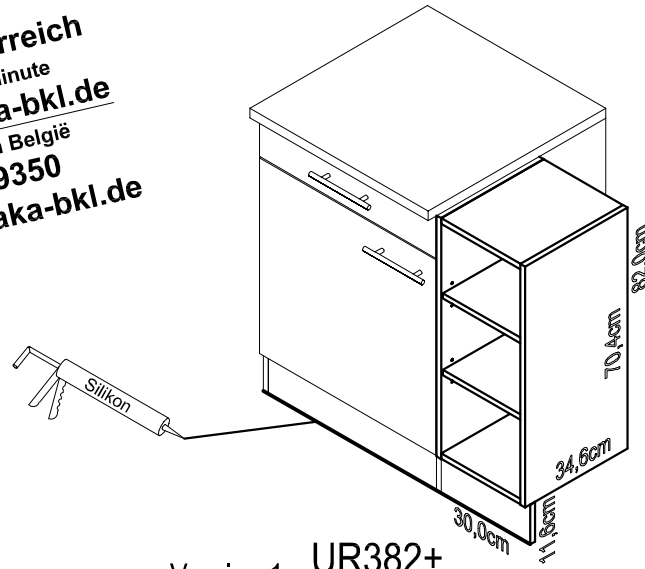

Version 1 UR382+
VUR382

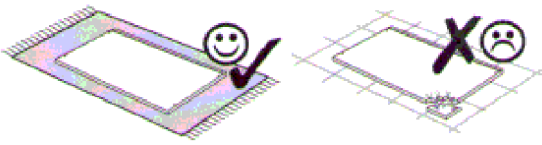
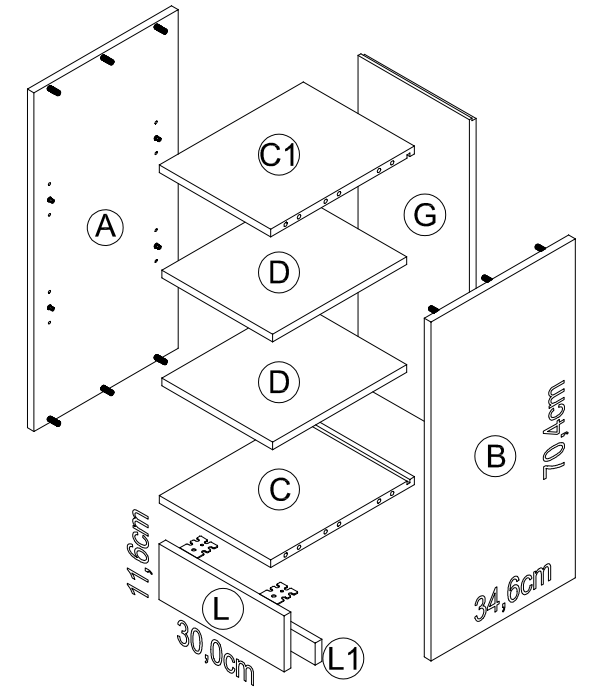
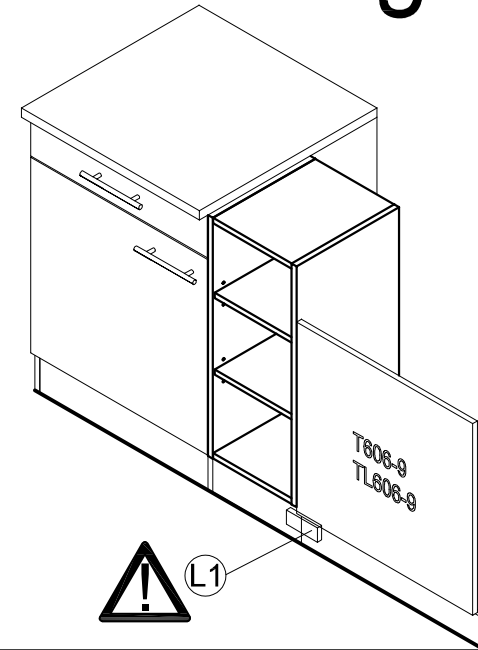

1 → 2 → 3 ...

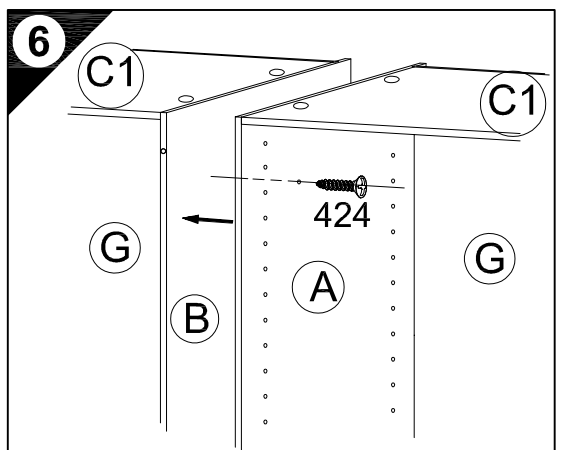
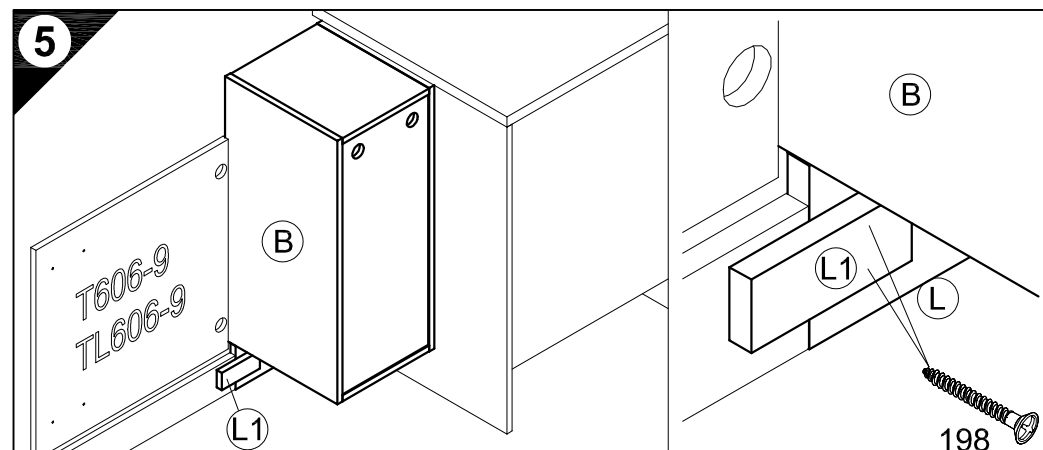
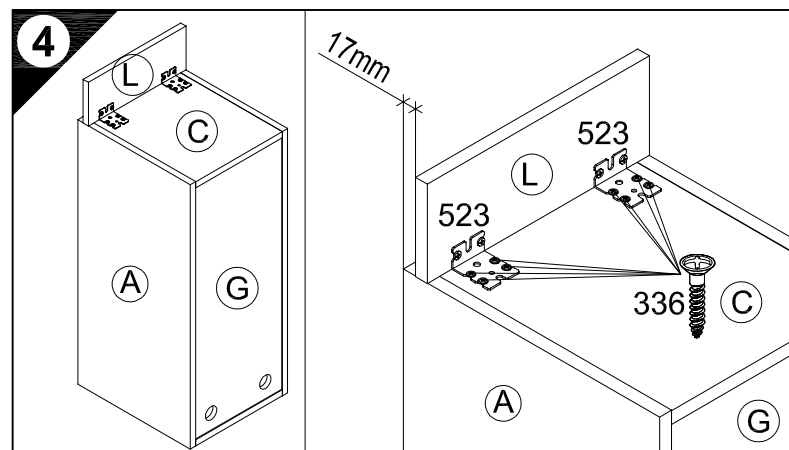
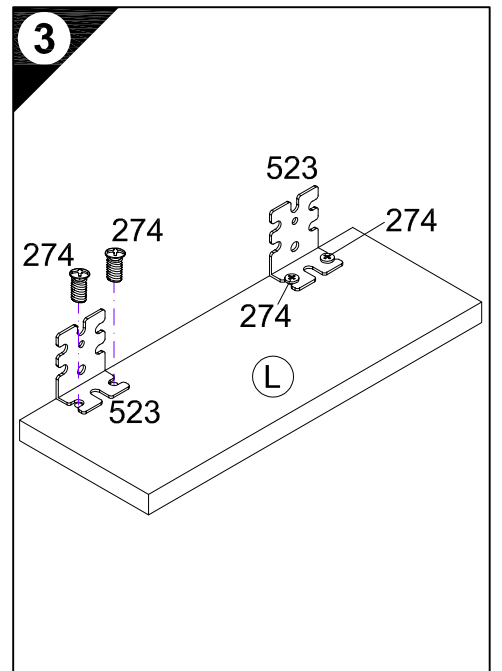
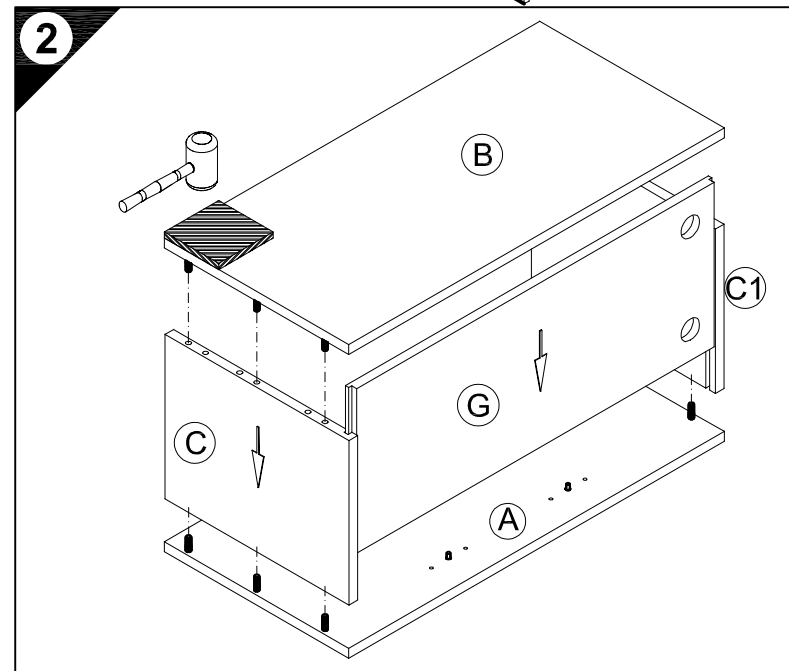
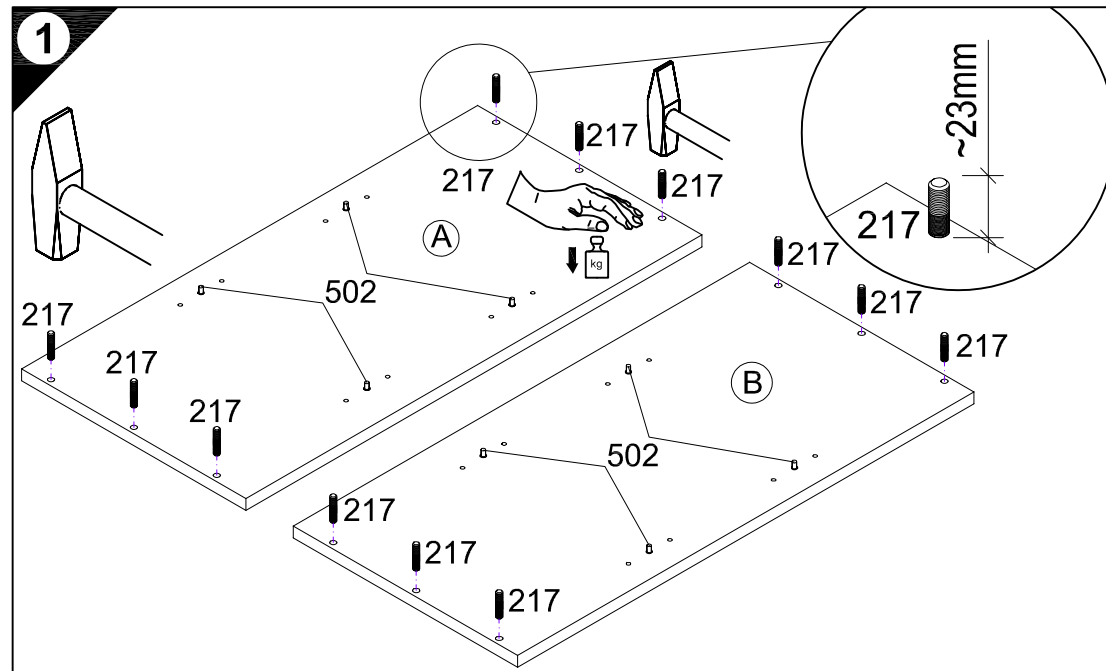
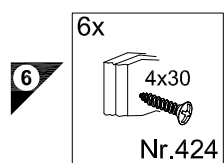
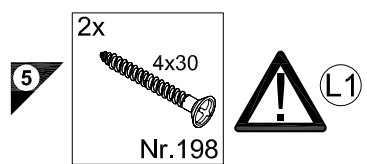
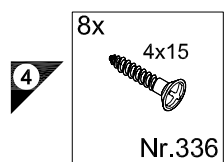
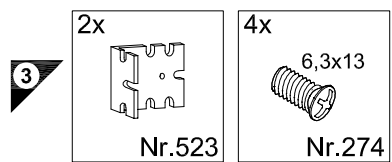
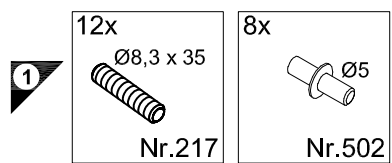

Ersatzteile/Spare parts/pièces de rechange/Reserveonderdelen/Piezas de recambio/Ricambi/Запасные части/Części zamienne/pótalkatrészek/Náhradní části/Nadomestni deli/varaosat/reservdelar/náhradné diely/piese de schimb/yedek parçalar

UR382+ / VUR382 | A| E940143 B| E940143 C| E940141 C1| E940141 D| E940145 G| E940144 L| E940139
UR382+ / VUR382 / T606-9 | A| E940143 B| E940143 C| E940141 C1| E940141 D| E940145 G| E940144 L| E940139 L1| E970977

OPTIFIT

JAKA-BKL GmbH
Jaka Straße 3
D-32351 Sternweide-Wehdem

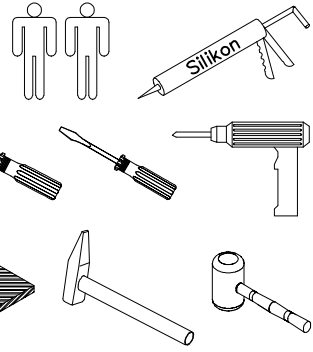

Service-Hotline
01805-678101
0,14€ pro Minute
++49 für Österreich
Auslandstarif pro Minute
service@jaka-bkl.de
voor Nederland en België
00800-40119350
benelux@jaka-bkl.de

Montageanleitung

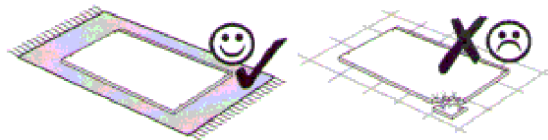
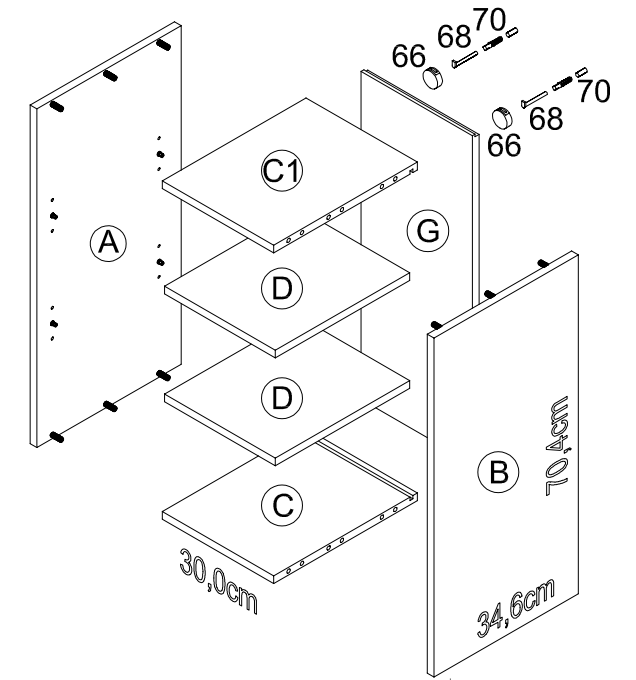
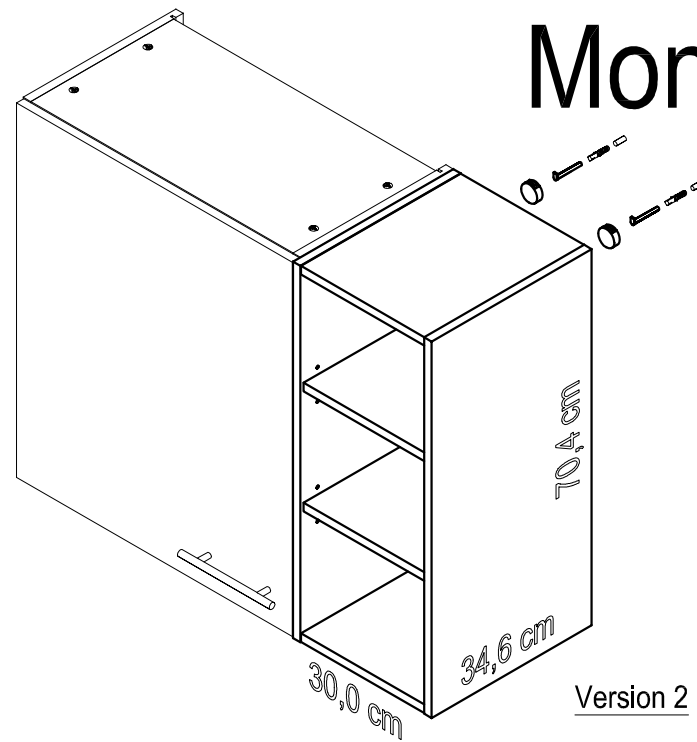

Version 2 UR382+
VUR382

1 → 2 → 3 ...

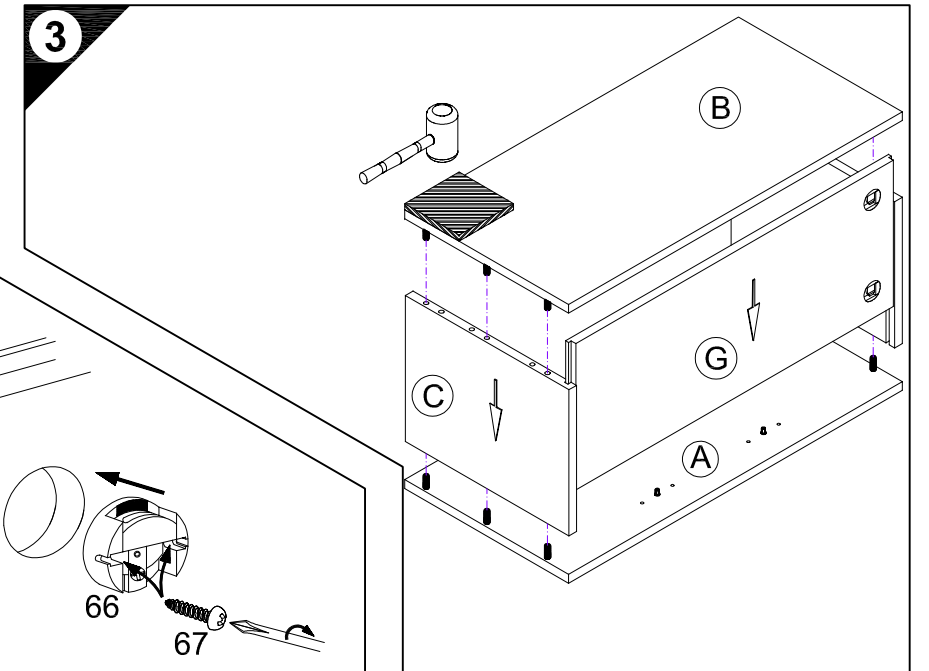
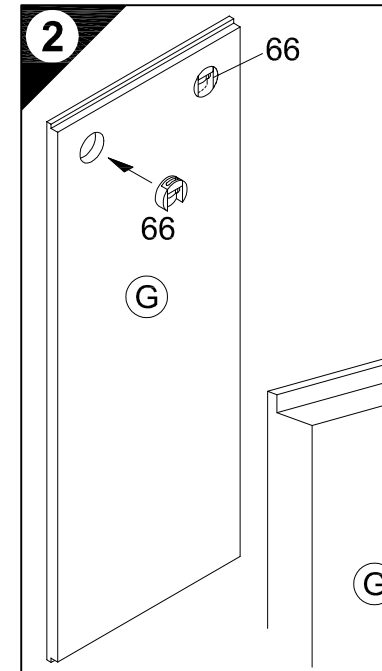
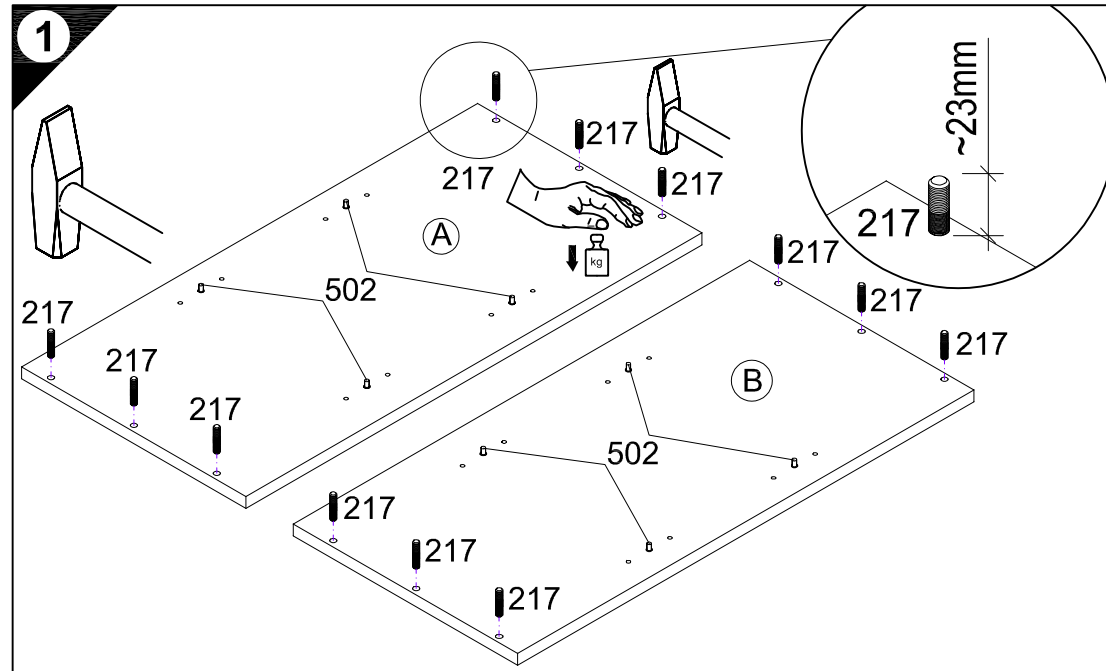
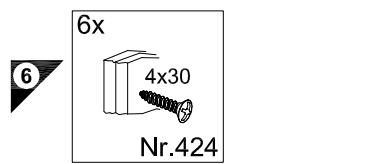
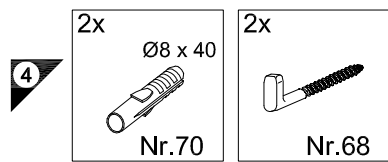
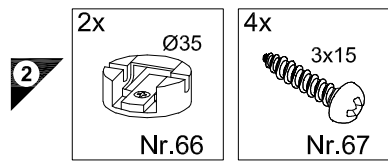
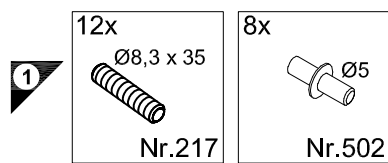

4

D Untergrund und Befestigungsmittel auf Eignung prüfen!
 GB Check substructure and fixings for suitability!
 F Contrôler si le support et les moyens de fixation sont bien adéquats !
 NL Ondergrond en bevestigingsmateriaal op functionaliteit controleren!
 E ¡Comprobar el suelo y los medios de fijación en cuanto a su aptitud!
 I Controllare l'idoneità del fondo e del materiale di fissaggio!
 RUS Основание и крепежный материал проверить на пригодность!
 PL Podłoże oraz materiały do zamocowania sprawdzić na ich przydatność!
 H Az alapfelületet és a rögzítő anyagokat megfelelőség szempontjából ellenőrizni kell!
 CZ Přezkoušejte podklad a vhodnost upevňovacích prostředků!
 SLO Preverite, če se ujemajo spodnja stran in pritrdilna sredstva!
 FIN Tarkista alustan ja kiinnitysvälineiden sopivuus!
 S Kontrollera att underlaget och fästmedlen är lämpliga!
 SK Preverte vhodnosť podkladu a upevňovacích prostriedkov!
 RO Verificați caracterul adecvat al suprafeței suport și al mijloacelor de fixare!
 TR Zeminin ve bağlanıtı elemanlarının uygunluğunu kontrol edin!

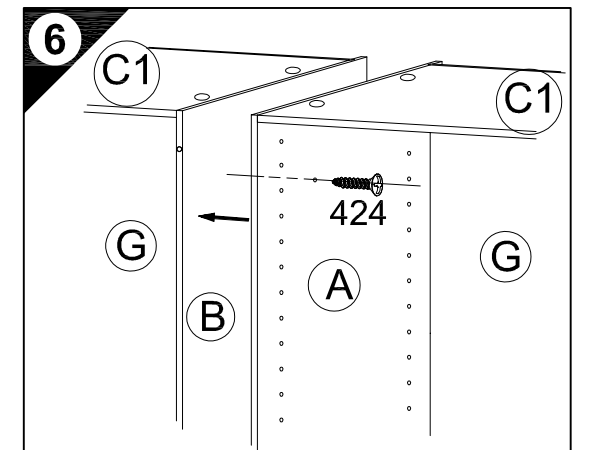
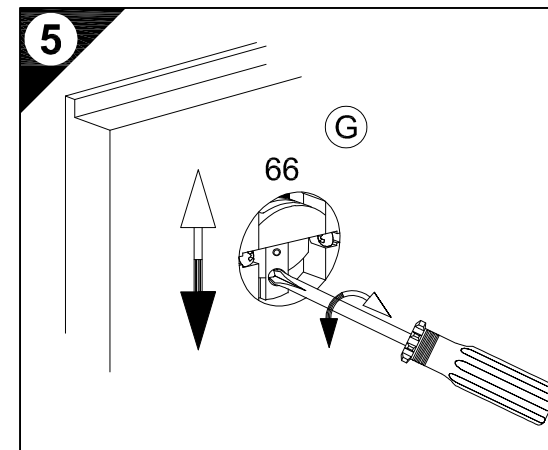

Ersatzteile/Spare parts/pièces de rechange/Reserveonderdelen/Piezas de recambio/Ricambi/Запасные части/Części zamiennie/pótalkatrészek/Náhradní části/Nadomestni deli/varaosat/reservdelar/náhradné diely/piese de schimb/yedek parçalar

UR382+ / VUR382 | A| E940143 B| E940143 C| E940141 C1| E940141 D| E940145 G| E940144

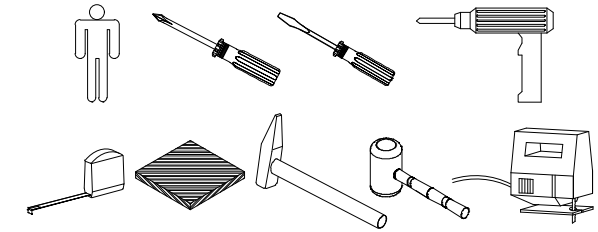

1 → 2 → 3 ...

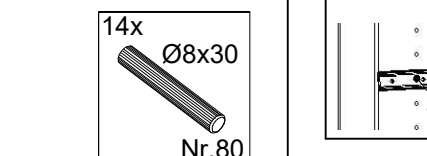
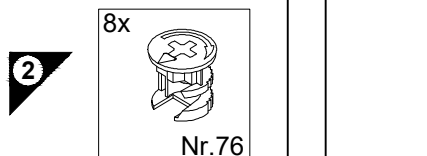
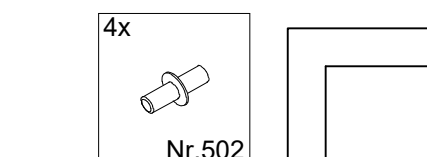
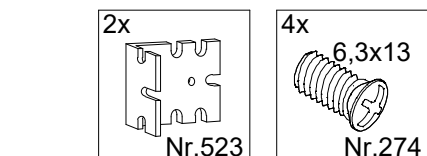
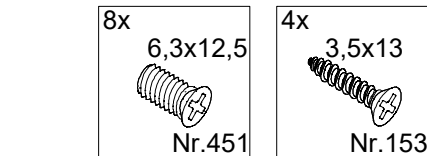
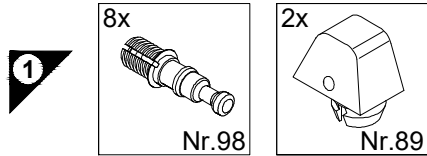

Service-Hotline
01805-678101
0,14€ pro Minute
++49 für Österreich
Auslandstarif pro Minute
service@jaka-bkl.de
voor Nederland en België
00800-40119350
benelux@jaka-bkl.de

Montageanleitung

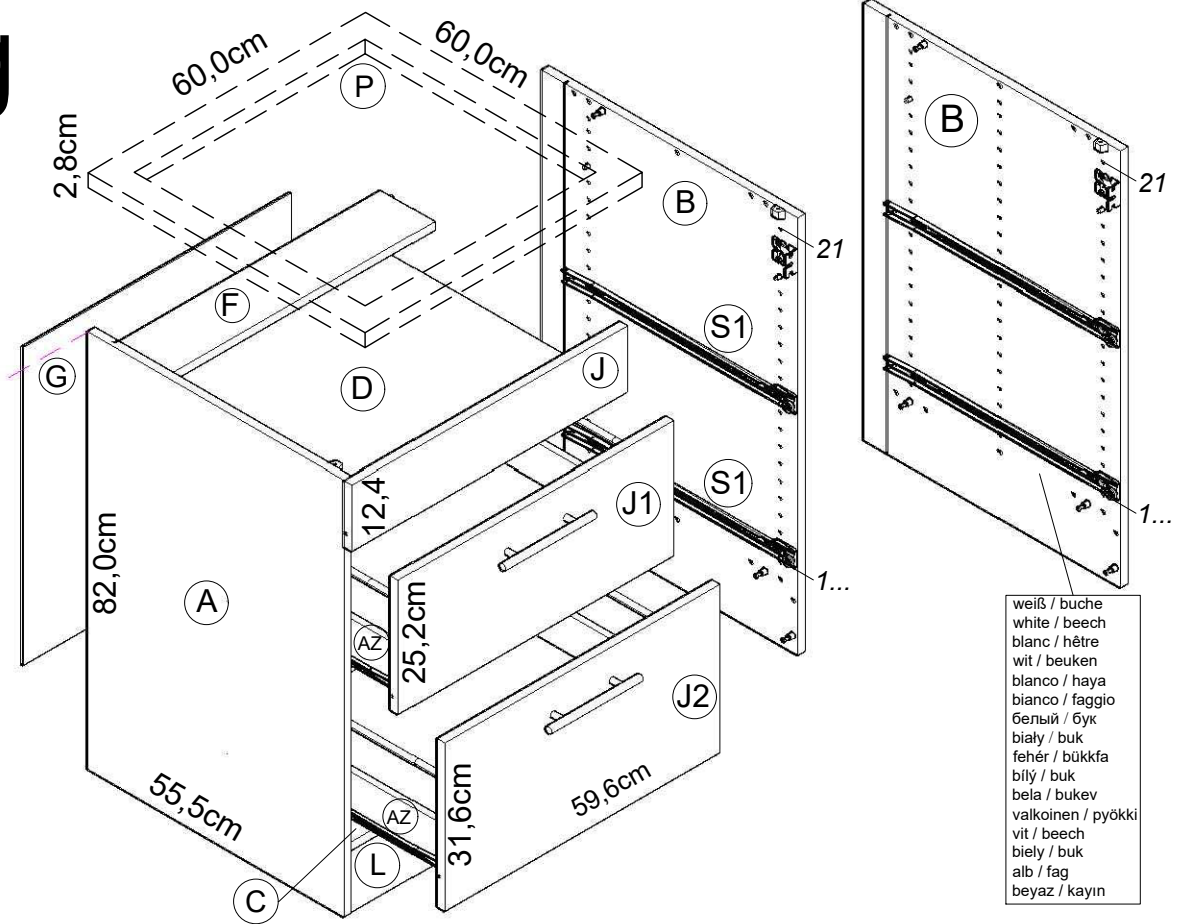
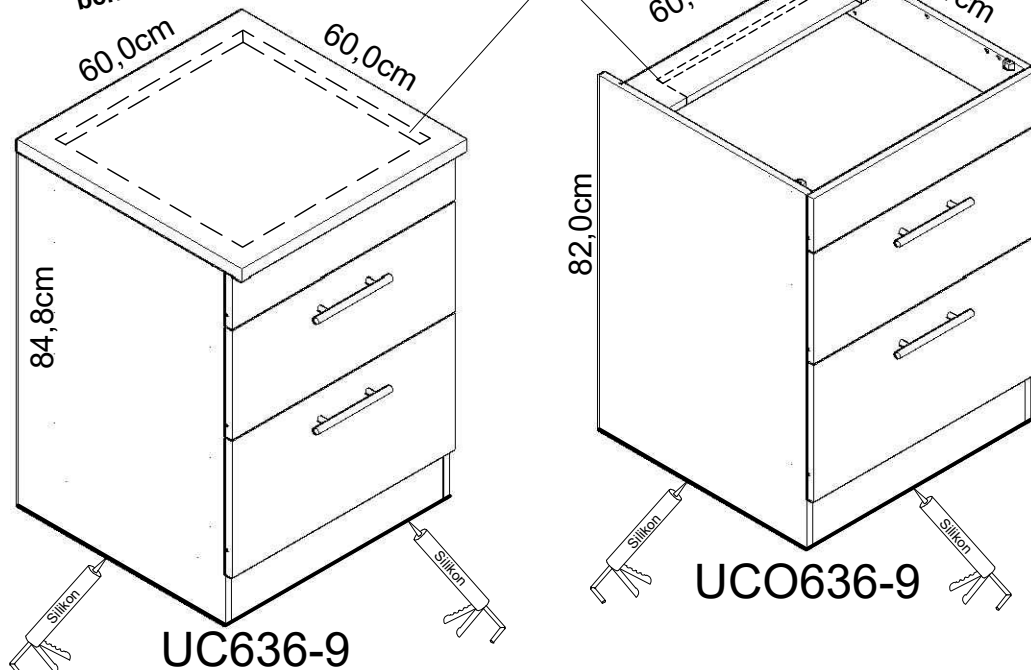

weiß / buche
white / beech
blanc / hêtre
wit / beuken
blanco / haya
bianco / faggio
белый / бук
biały / buk
fehér / bükkfa
bílý / buk
bela / bukev
valkoinen / pyökki
vit / beech
biely / buk
alb / fag
beyaz / kayın

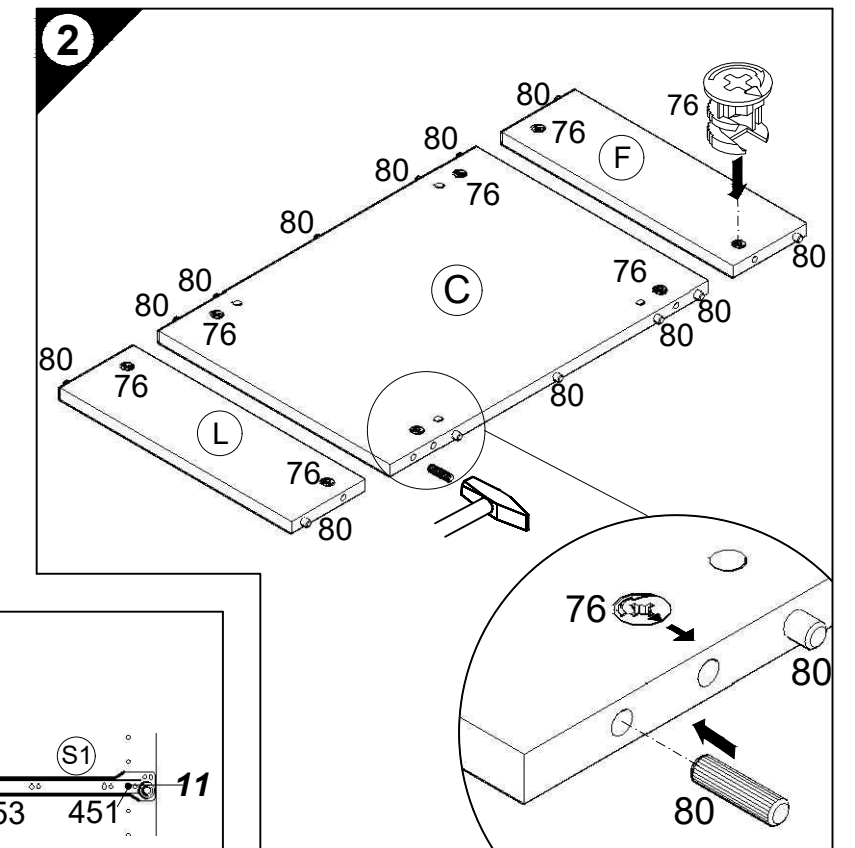
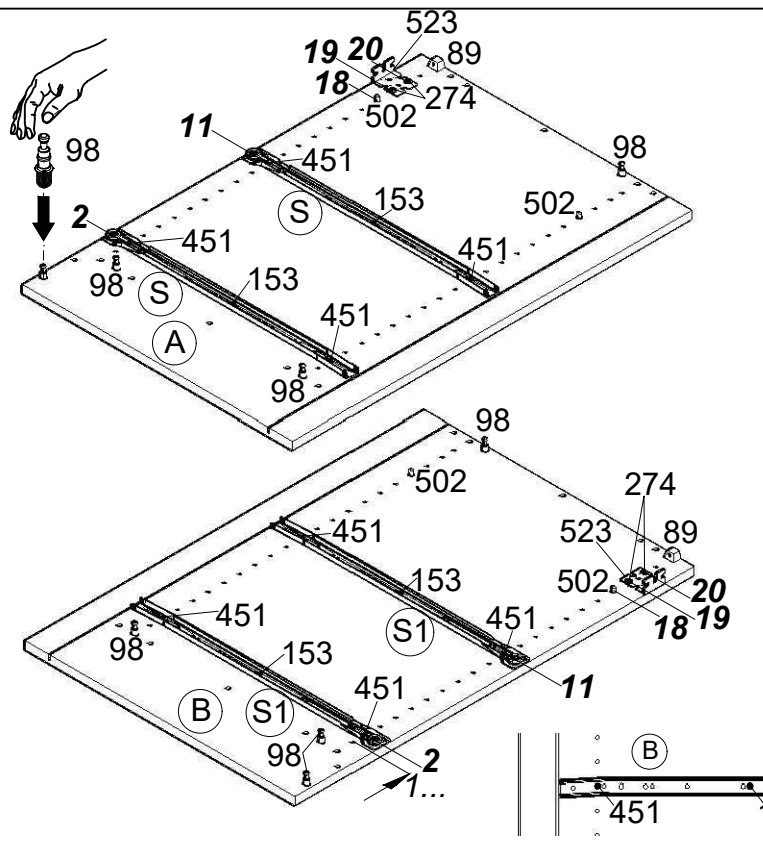
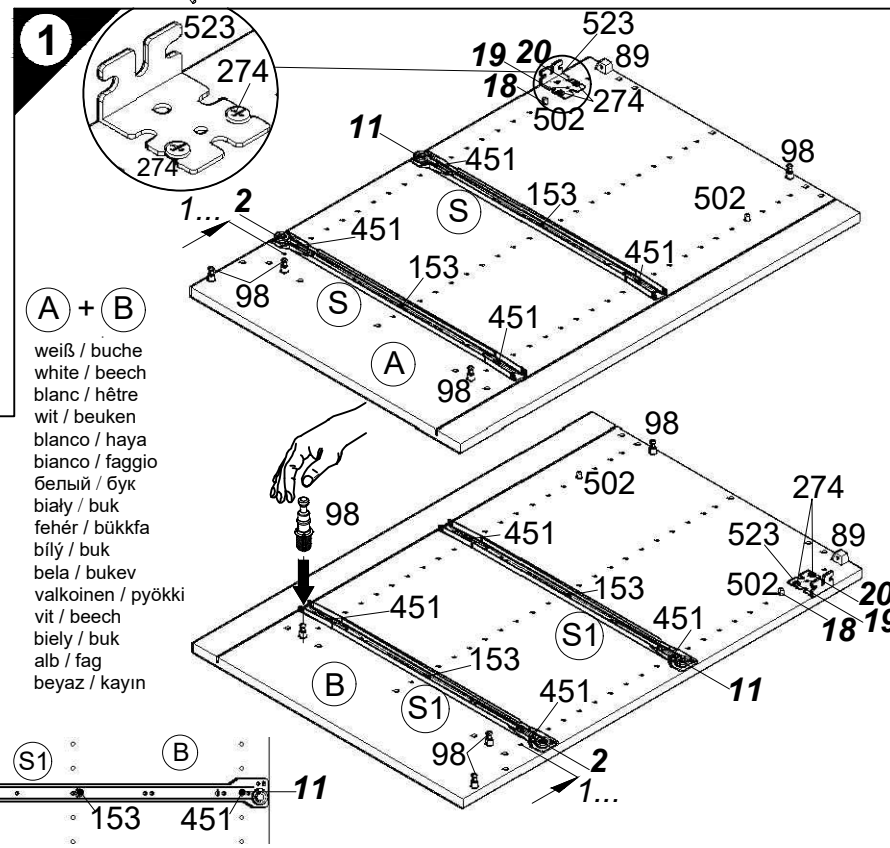

Ersatzteile/Spare parts/pièces de rechange/Reserveonderdelen/Piezas de recambio/Ricambi/Запасные части/Części zamienne/pótalkatrészek/Náhradní části/Nadomestni deli/varaosat/reservdelar/náhradné diely/Utilizați piese de schimb/Yedek parçalar

60cm UC636-9	[A] E961021	[B] E961022	[C] E954223	[D] E950303	[F] E970973	[G] E970092	[J] E947562	[J1] E947591	[J2] E947645	[L] E970973	[P] E540103	[S] E946155	[S1] E946155
weiß/buche UC636-9	[A] E981021	[B] E981022	[C] E954223	[D] E950303	[F] E970973	[G] E970092	[J] E947562	[J1] E947591	[J2] E947645	[L] E970973	[P] E540103	[S] E946155	[S1] E946155
60cm UCO636-9	[A] E961021	[B] E961022	[C] E954223	[D] E950303	[F] E970973	[G] E970092	[J] E947562	[J1] E947591	[J2] E947645	[L] E970973	[S] E946155	[S1] E946155	
weiß/buche UCO636-9	[A] E981021	[B] E981022	[C] E954223	[D] E950303	[F] E970973	[G] E970092	[J] E947562	[J1] E947591	[J2] E947645	[L] E970973	[S] E946155	[S1] E946155	

1 → 2 → 3 ...

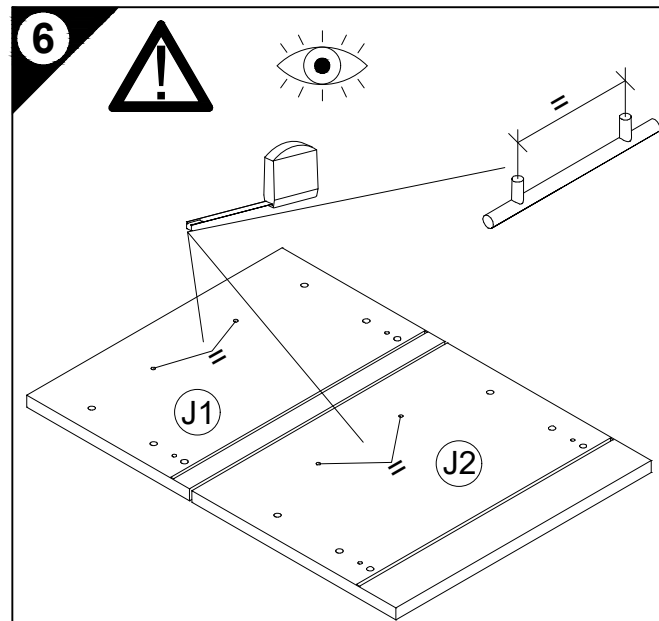
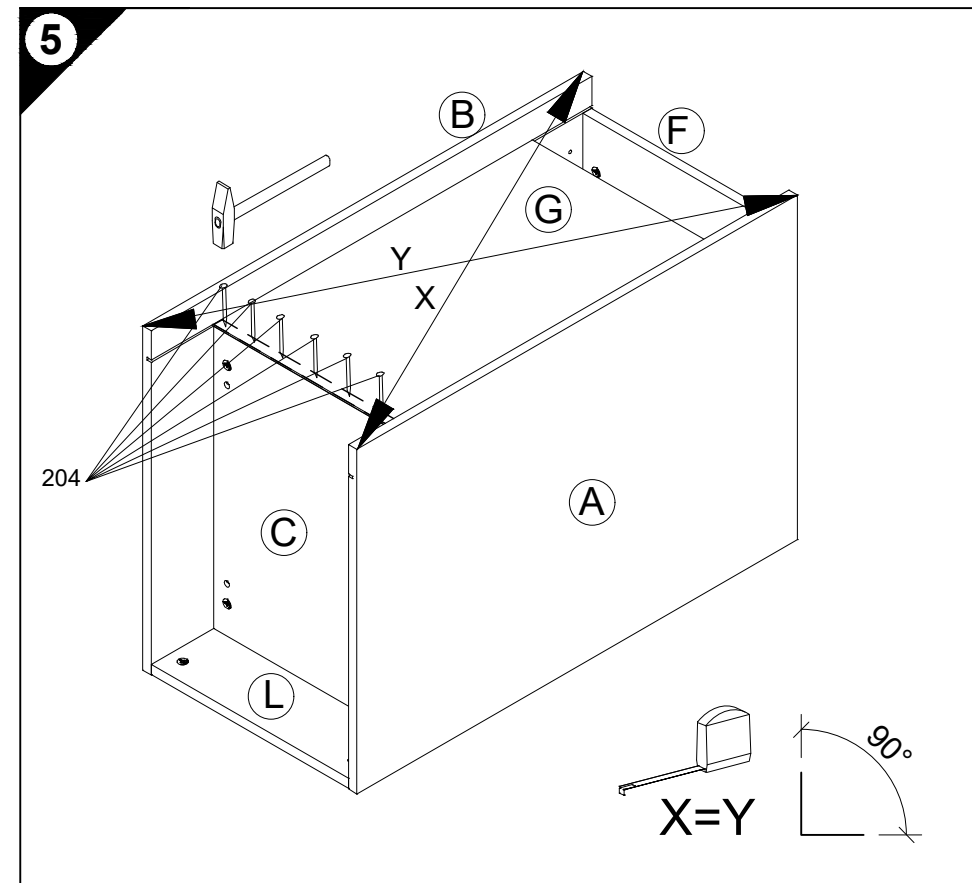
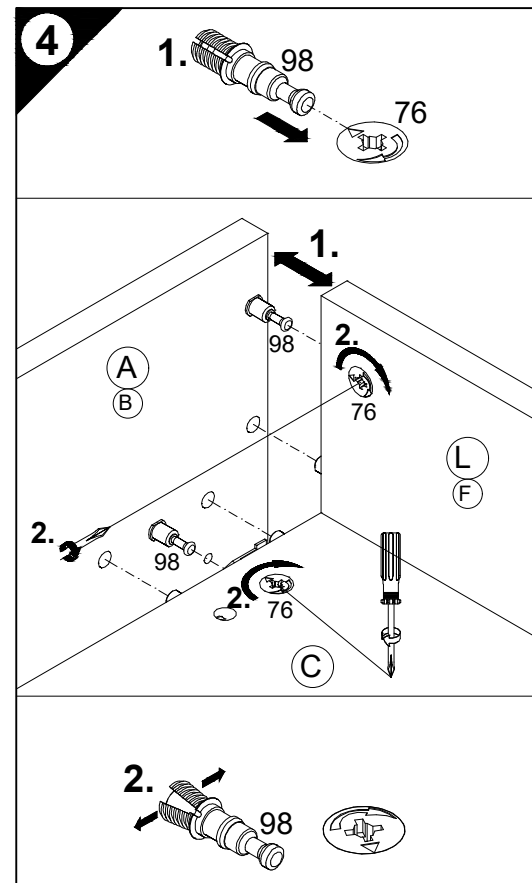
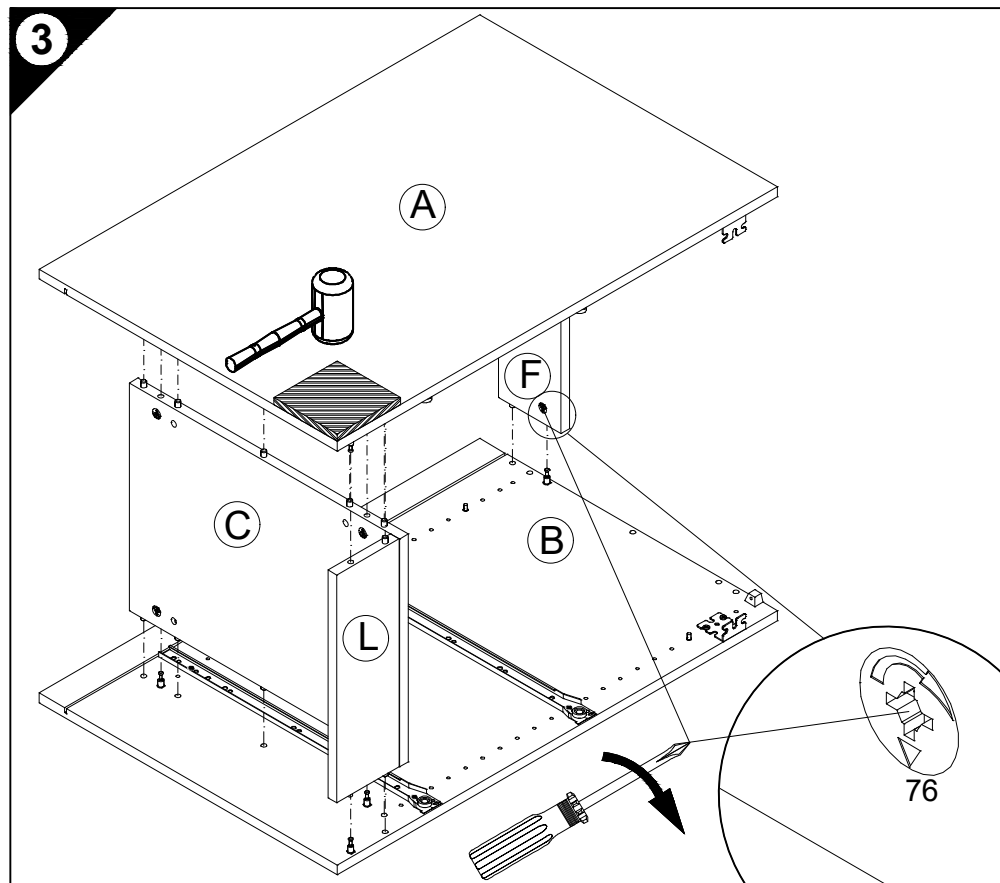
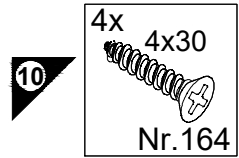
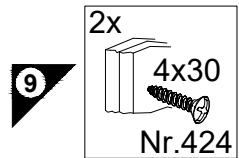
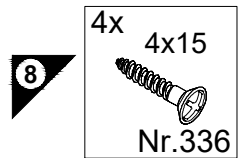
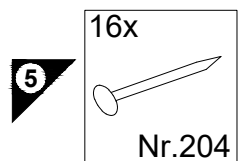

D Holzunterlage verwenden!
Front andrücken, scharfen Bohrer verwenden
und mit wenig Druck durchbohren!

GB Use a wooden base!
Press front down, use sharp drill bit
and, by applying slight pressure, drill a hole

F Utiliser un support en bois !
Appuyer sur la façade, utiliser un foret bien affûté
et percer en appliquant une faible pression !

NL Houten onderlegger gebruiken!
Druk het front aan, gebruik een scherpe boor
en oefen bij het boren weinig druk uit!

E ¡Utilizar una base de madera!
¡Presionar el frente, utilizar una broca afilada
y taladrar con poca presión!

I Utilizzare una base di legno!
Appoggiare la facciata, utilizzare una punta di trapano affilata
e trapanare esercitando solo una leggera pressione!

RUS Использовать деревянную подложку!
Прижать фасад, использовать острое сверло
и просверлить с незначительным давлением!

PL Używać podkładkę z drewna!
Docisnąć front, użyć oстрego wiertła
i przewiercić, używając małej siły nacisku!

H Alkalmazzon fa alátétet!
Nyomja le az előlapot, használjon éles fúrót,
és kis nyomással fúrja át!

CZ Použijte dřevěný podklad!
Přitlačte čelo, použijte ostrý vrták
a provrtějte pomocí malého tlaku!

SLO Uporabite leseno podlago!
Pritisnite ličnico ter z ostrim svedrom
in z majhnim pritiskom izvrtajte luknjo!

FIN Käytä puualustaa!
Paina etulevy paikoilleen, käytä terävää poranterää
ja poraa reikä vain kevyesti painamalla!

S Använd ett träunderlag!
Tryck fronten mot underlaget, använd vass borrh
och borra igenom med ett lätt tryck!

SK Použite drevený podklad!
Přitlačte front, použite ostrý vrták a prevrtajte miernym tlakom!

RO suport de lemn! Împingeți frontul, utilizați un burghiu ascuțit
și perforați exercitând doar o presiune redusă!

TR Önden bastırın, keskin matkap ucu kullanın ve az basınç
uygulayarak delin!

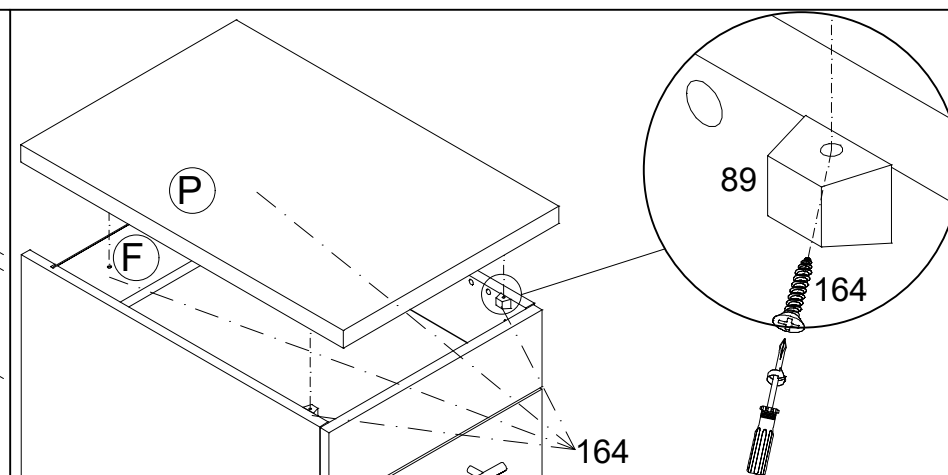
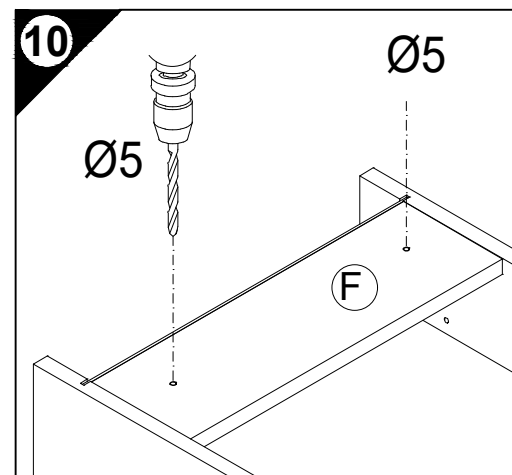
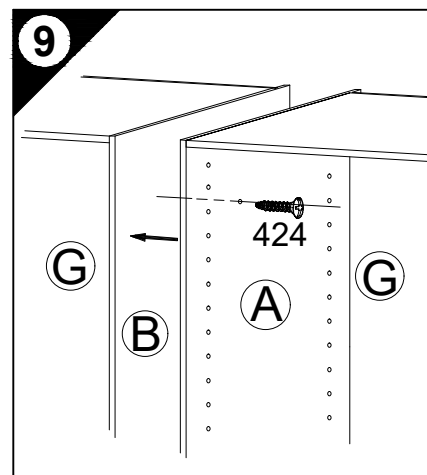
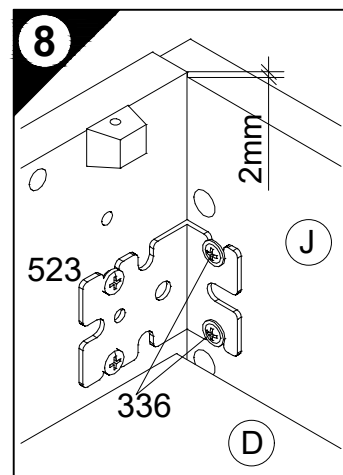
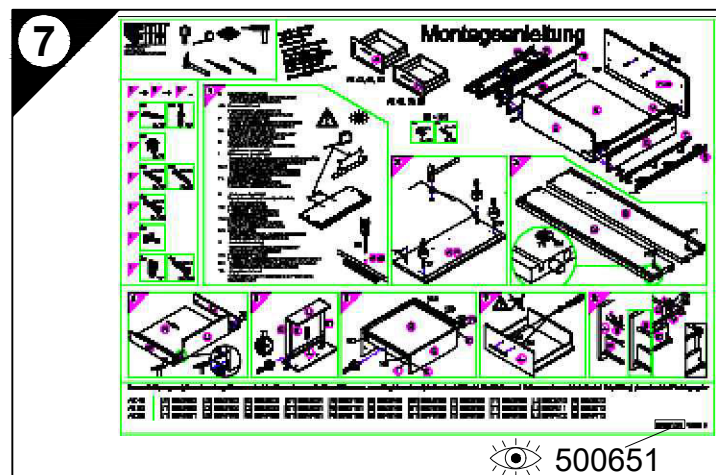
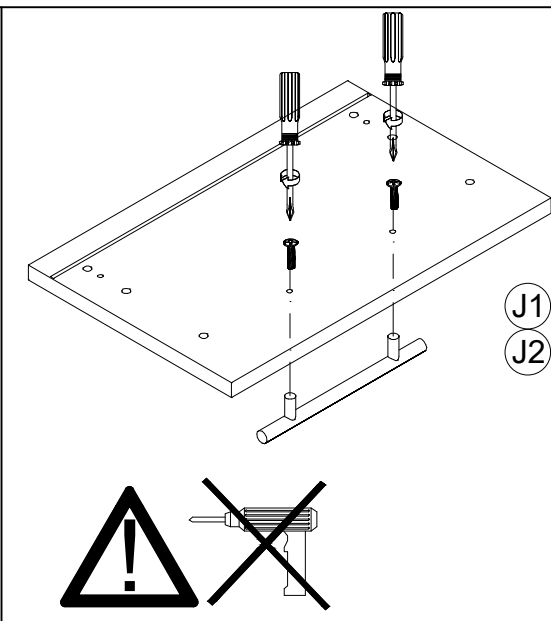
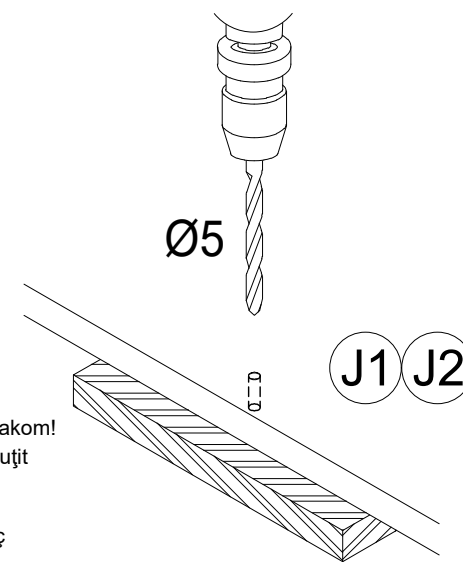

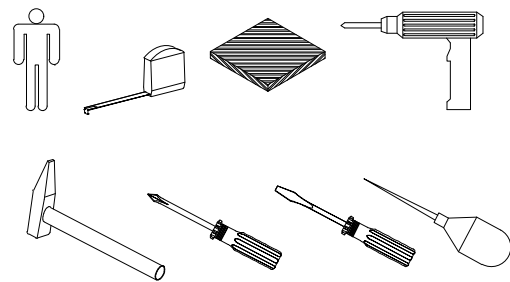

Service-Hotline
01805-678101
0,14€ pro Minute
++49 für Österreich
Auslandstarif pro Minute
service@jaka-bkl.de
voor Nederland en België
00800-40119350
benelux@jaka-bkl.de

Montageanleitung

AZ 40, 50, 60

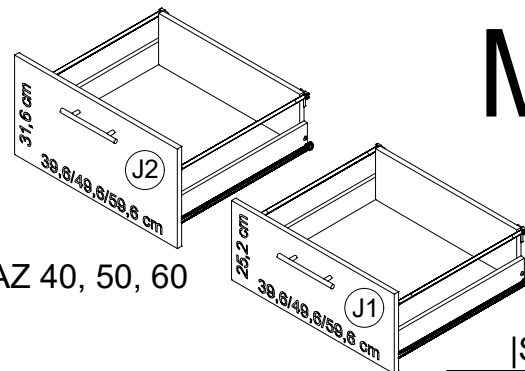

AZ 40, 50, 60

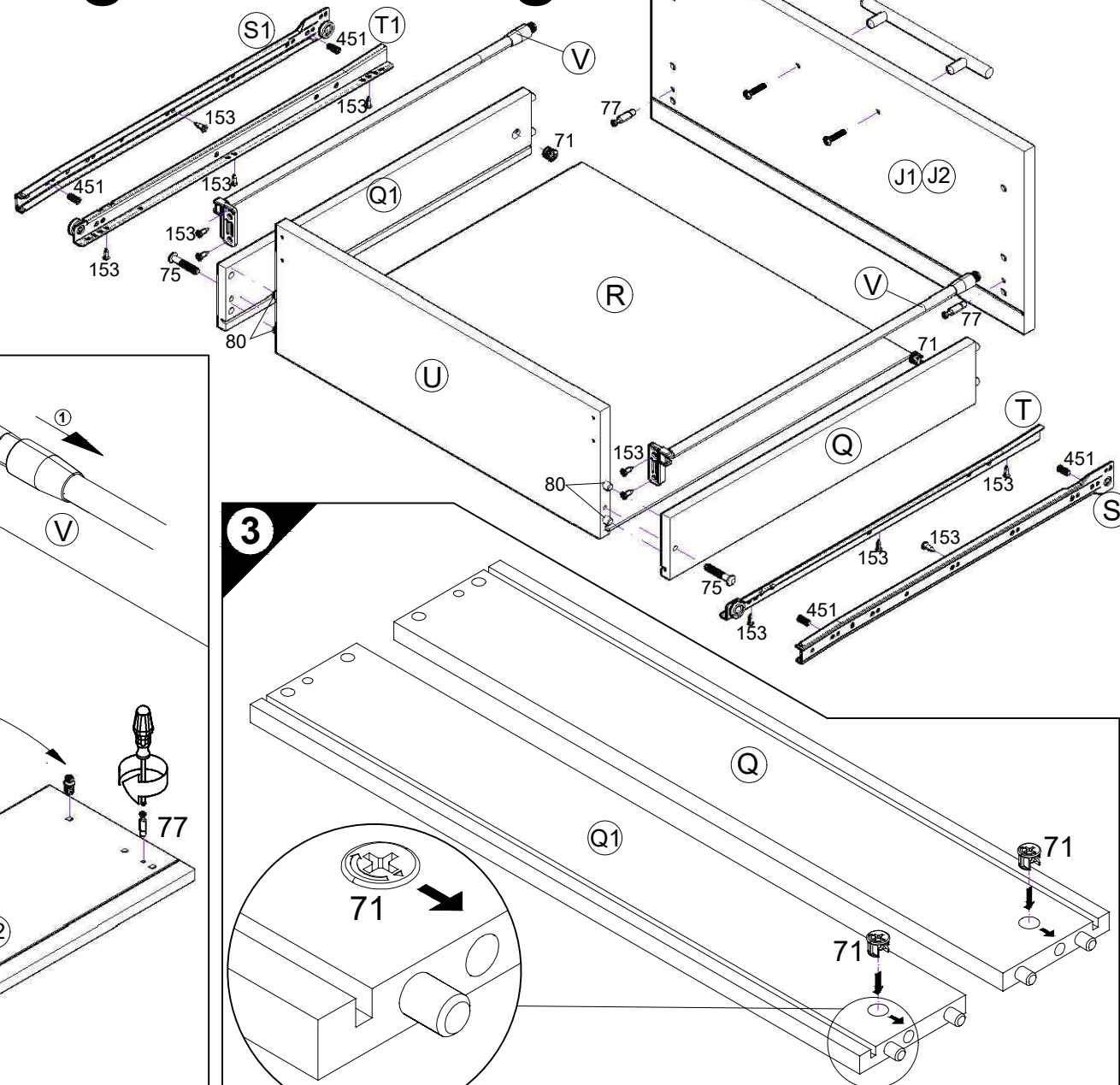
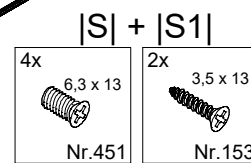

1 → 2 → 3 ...

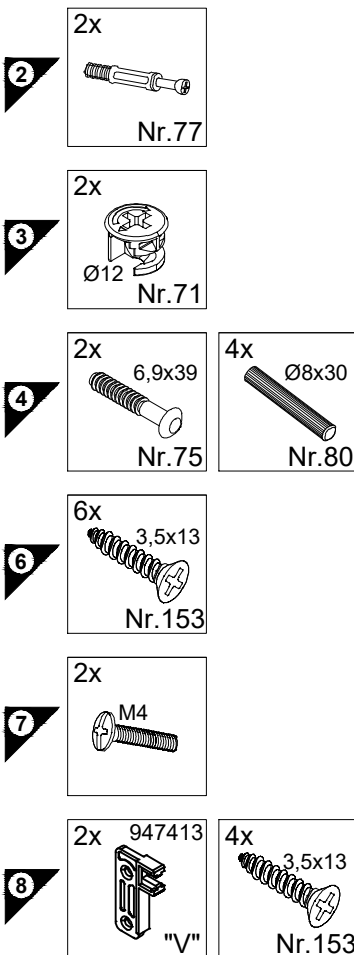

1

D Holzunterlage verwenden!
Front andrücken, scharfen Bohrer verwenden und mit wenig Druck durchbohren!

GB Use a wooden base!
Press front down, use sharp drill bit and, by applying slight pressure, drill a hole

F Utiliser un support en bois!
Appuyer sur la façade, utiliser un foret bien affûté et percer en appliquant une faible pression!

NL Houten onderlegger gebruiken!
Druk het front aan, gebruik een scherpe boor en oefen bij het boren weinig druk uit!

E ¡Utilizar una base de madera!
¡Presionar el frente, utilizar una broca afilada y taladrar con poca presión!

I Utilizzare una base di legno!
Appoggiare la facciata, utilizzare una punta di trapano affilata e trapanare esercitando solo una leggera pressione!

RUS Использовать деревянную подложку!
Прижать фасад, использовать острое сверло и просверлить с незначительным давлением!

PL Użyć podkładkę z drewna!
Docisnąć front, użyć ostrygo wiertła i przewiercić, używając małej siły nacisku!

H Alkalmazzon fa alátét!
Nyomja le az előlapot, hasznájon éles fűrt, és kis nyomással fúrja át!

CZ Použijte dřevný podklad!
Přitlačte čelo, použijte ostrý vrták a provrtejte pomocí malého tlaku!

SLO Uporabite leseno podlaglo!
Pritisnite ličnico ter z ostrim svedrom in z majhnim pritiskom izvrtajte luknjo!

FIN Käytä puualustaa!
Paina etulevy paikoilleen, käytä terävää poranterää ja poraa reikä vain kevyesti painamalla!

S Använd ett träunderlag!
Tryck fronten mot underlaget, använd vass borrh och borra igenom med ett lätt tryck!

SK Použite drevený podklad!
Přitlačte front, použite ostrý vrták a prevrtajte miernym tlakom!

RO suport de lemn!
Împingeți frontul, utilizați un burghiu ascuțit și perforați exercitând doar o presiune redusă!

TR Ahşap taban kullanın!
Önden bastırın, keskin matkap ucu kullanın ve az basınç uygulayarak delin!

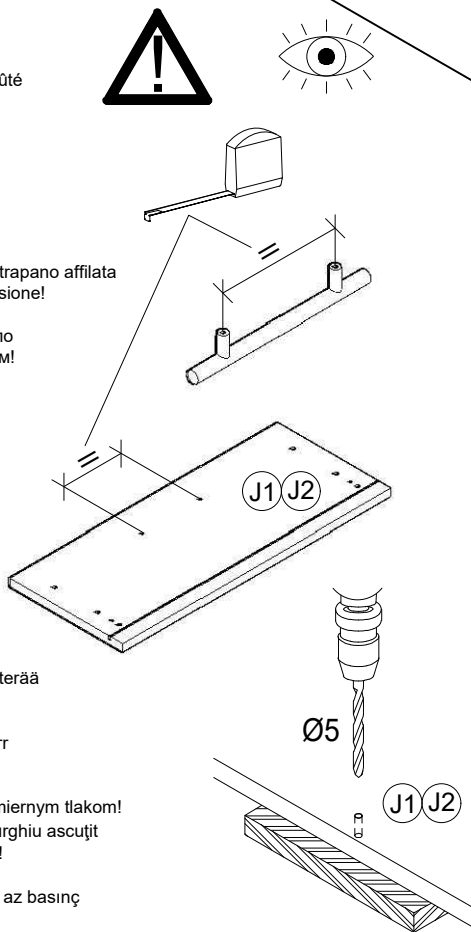

2

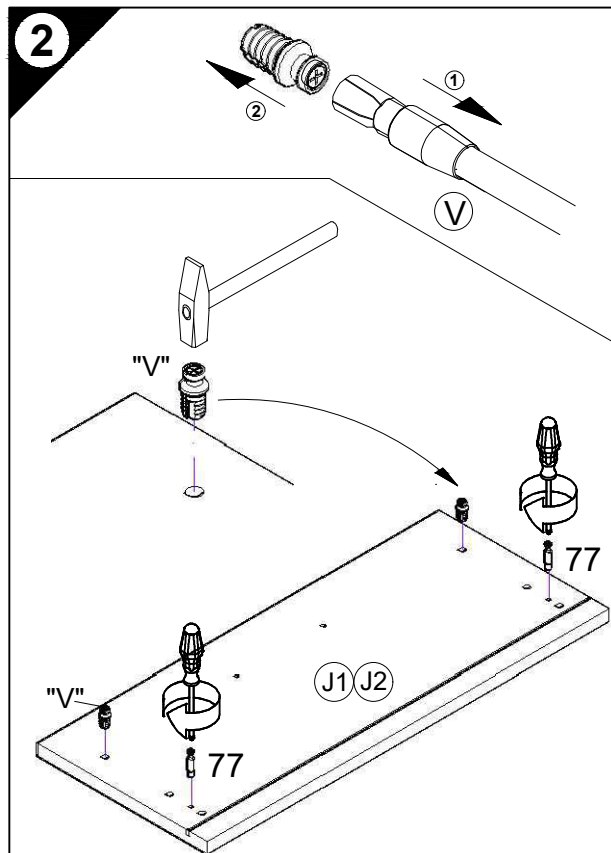

3

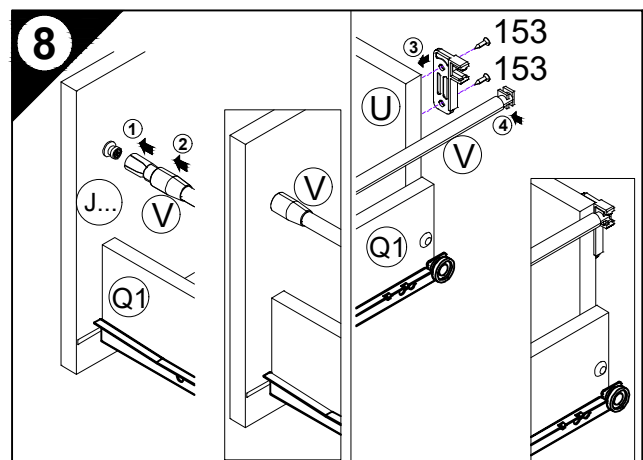
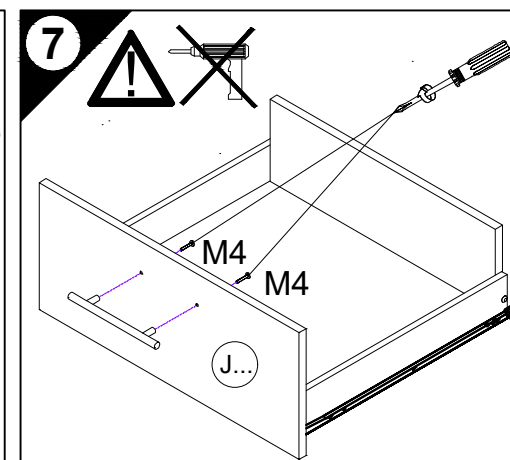
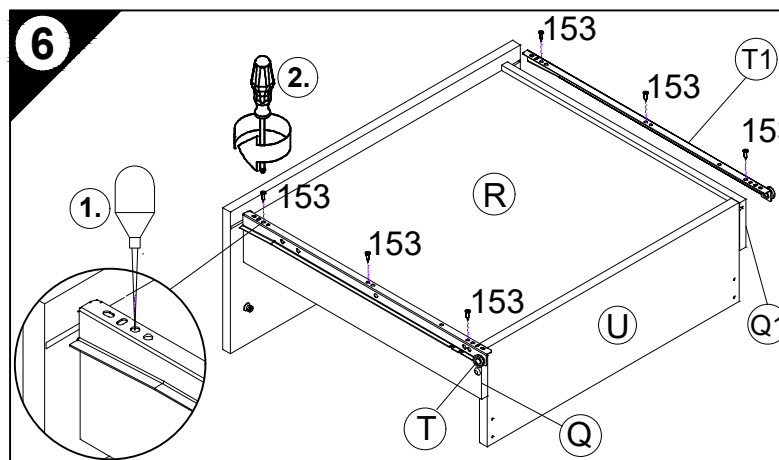
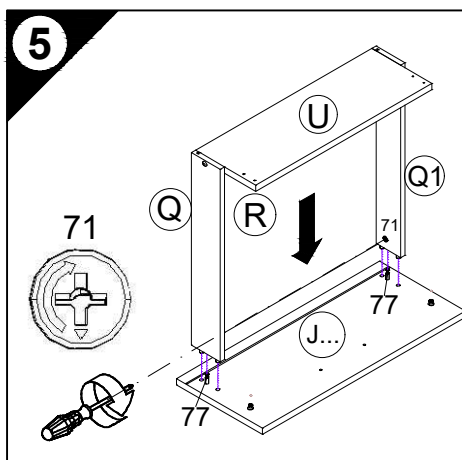
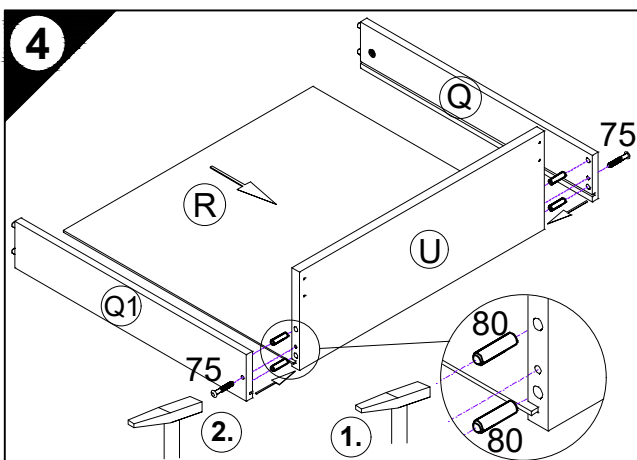
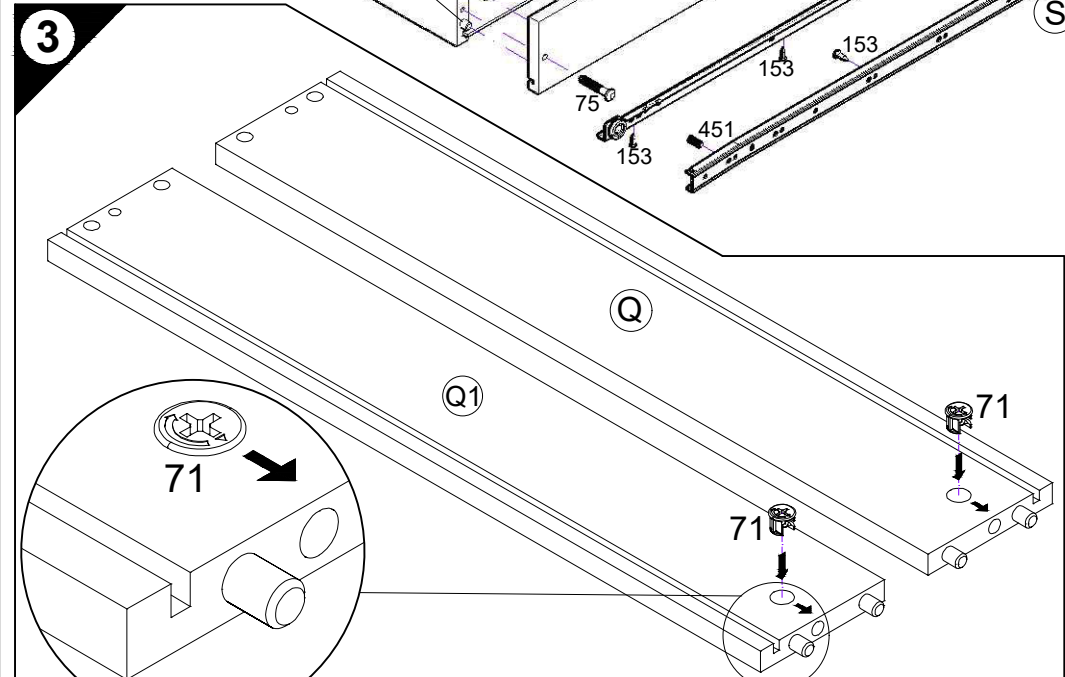

Ersatzteile/Spare parts/pièces de rechange/Reserveonderdelen/Piezas de recambio/Ricambi/Запасные части/Części zamienne/pótkatárszerek/Náhradní části/Nadomestni deli/varaosat/reservdelar/náhradné diely/Utilizați piese de schimb/Yedek parçalar

AZ 40	J1 E947593	J2 E947643	Q E947400	Q1 E947401	R E970152	S E946155	S1 E946155	T E946155	T1 E946155	U E947410	V E947413
AZ 50	J1 E947592	J2 E947644	Q E947400	Q1 E947401	R E970151	S E946155	S1 E946155	T E946155	T1 E946155	U E947411	V E947413
AZ 60	J1 E947591	J2 E947645	Q E947400	Q1 E947401	R E970150	S E946155	S1 E946155	T E946155	T1 E946155	U E947412	V E947413

**OPTI
FIT**

JAKA-BKL GmbH
Jaka Straße 3
D-32351 Stemwede-Wehdem

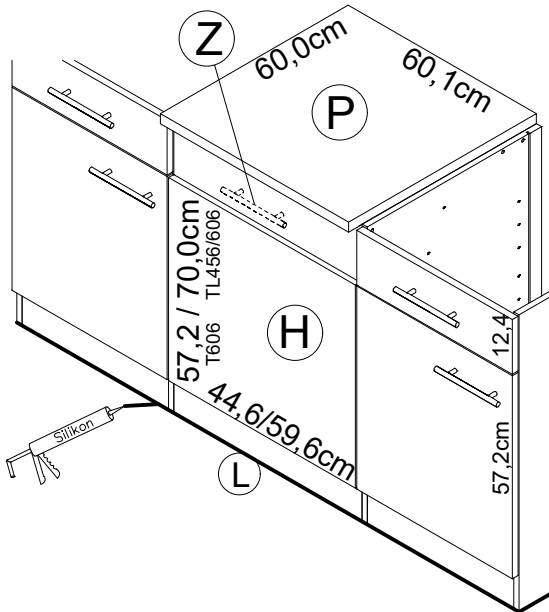
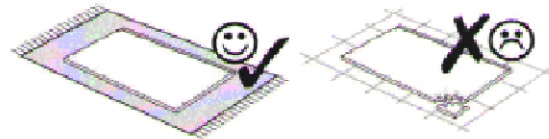
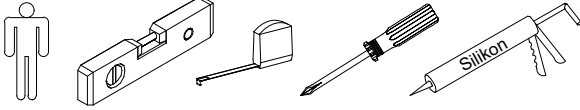

Service-Hotline
01805-678101
0,14€ pro Min.
+49 für Österreich
Auslandstarif pro Min.
service@jaka-bkl.de
voor Nederland en België
00800-40119350
benelux@jaka-bkl.de

Montageanleitung

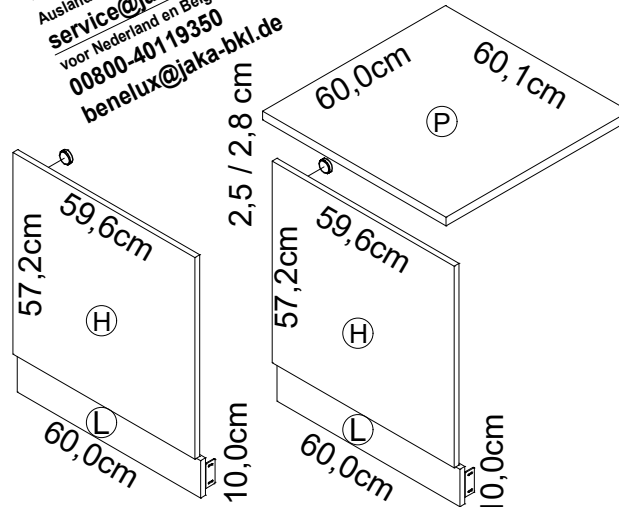

T606-6
T606-9

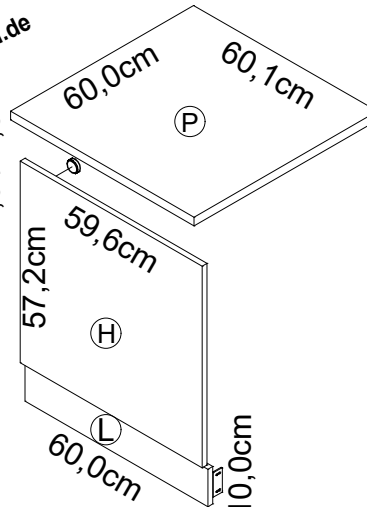

T606APL-6
T606APL-9

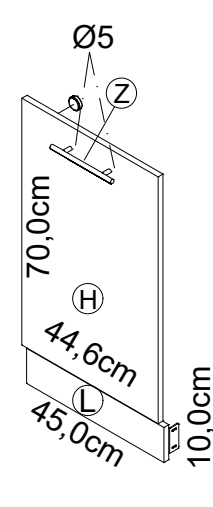

TL456-9

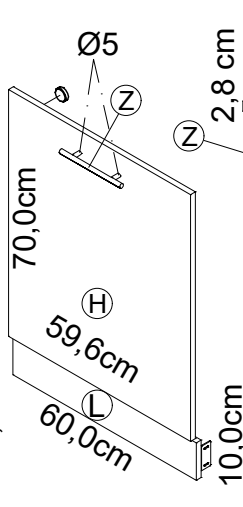

TL606-9

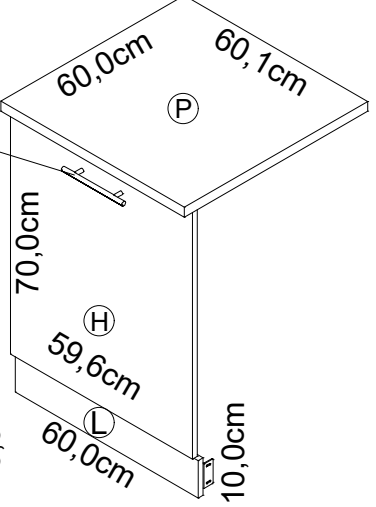

TL606APL-9

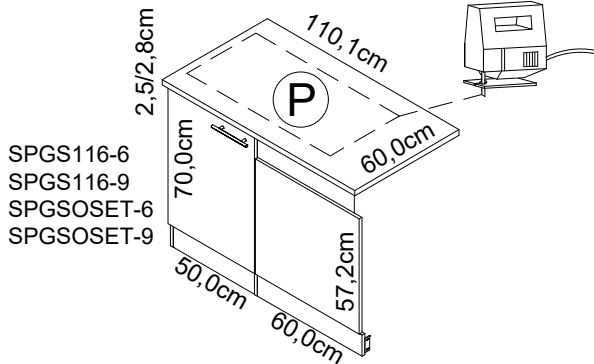

SPGS116-6
SPGS116-9
SPGSOSET-6
SPGSOSET-9

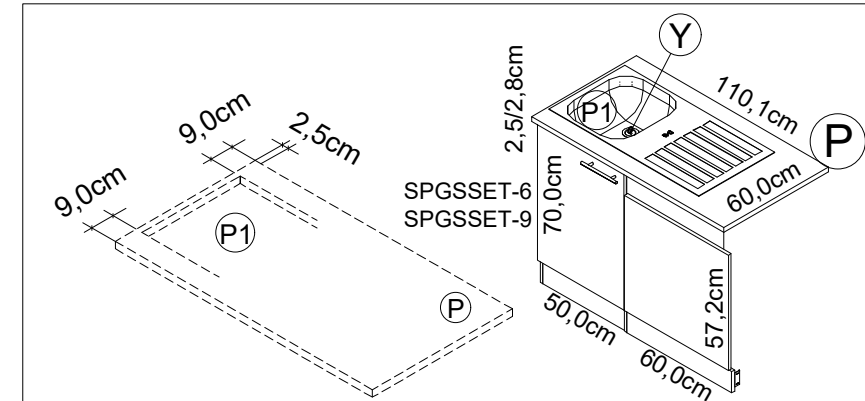

SPGSSET-6
SPGSSET-9

Ersatzteile/Spare parts/pièces de rechange/Reserveonderdelen/Piezas de recambio/Ricambi/Запасные части/Części zamienne/
półaktrészek/Náhradní části/Nadomestni deli/varaosat/reservdelar/náhradné diely/Utilizați piese de schimb/Yedek parçalar

T 606-6	H E980611	L E946060	
T 606-9	H E940611	L E946060	
T 606APL-6	H E980611	L E946060	P E441103
T 606APL-9	H E940611	L E946060	P E540103

TL 456-9	
TL 606-9	
TL 606APL-9	
SPGS...-6	
SPGS...-9	

H E940620	L E946059	Z E447100
H E940621	L E946060	Z E447100
H E940621	L E946060	P E540103 Z E447100
P E441100	P1 E448292	Y E446500
P E540100	P1 E448292	Y E446500

1 → 2 → 3 ...

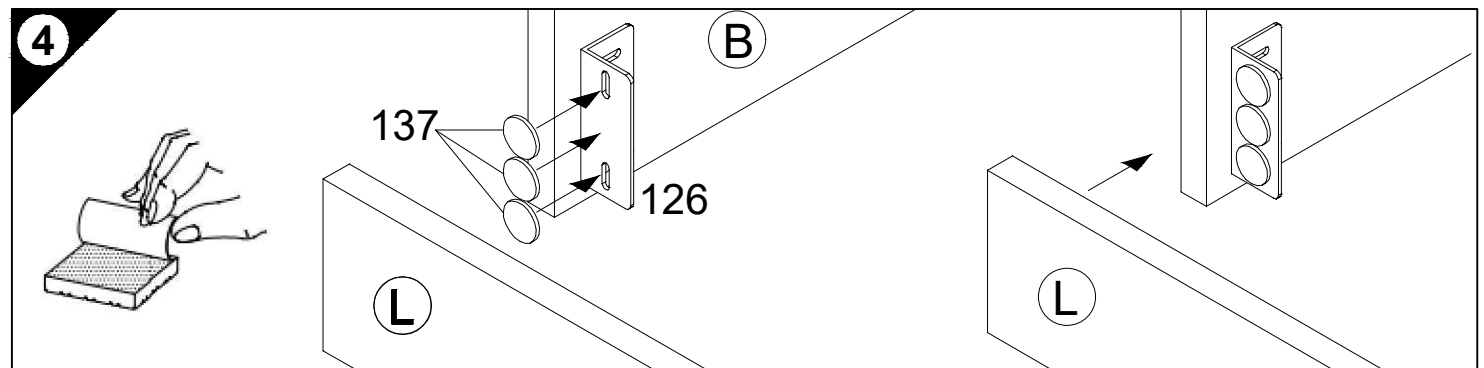
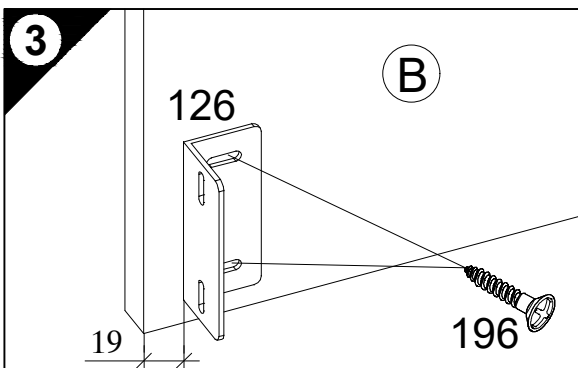
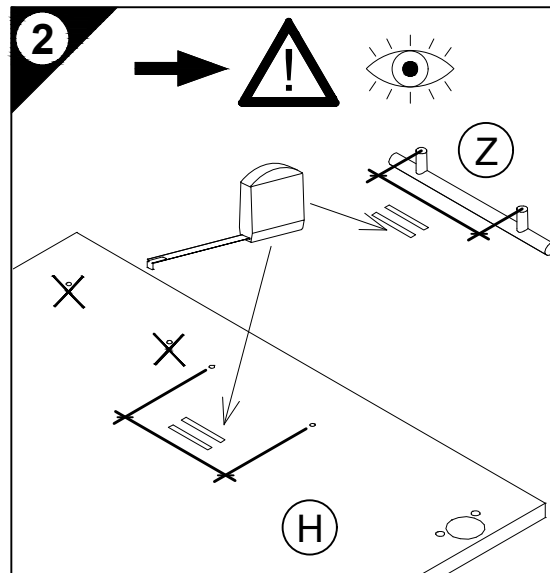
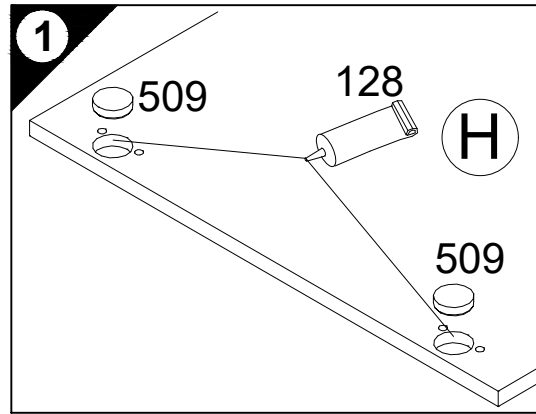
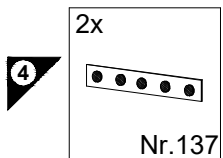
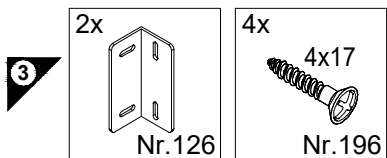
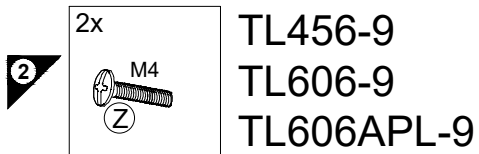
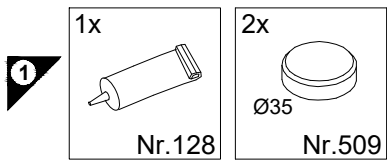

- D Holzunterlage verwenden!
Front andrücken, scharfen Bohrer verwenden und mit wenig Druck durchbohren!
- GB Use a wooden base!
Press front down, use sharp drill bit and, by applying slight pressure, drill a hole
- F Utiliser un support en bois !
Appuyer sur la façade, utiliser un foret bien affûté et percer en appliquant une faible pression !
- NL Houten onderlegger gebruiken!
Druk het front aan, gebruik een scherpe boor en oefen bij het boren weinig druk uit!
- E ¡Utilizar una base de madera!
¡Presionar el frente, utilizar una broca afilada y taladrar con poca presión!
- I Utilizzare una base di legno! Appoggiare la facciata, utilizzare una punta di trapano affilata e trapanare esercitando solo una leggera pressione!
- RUS Использовать деревянную подложку!
Прижать фасад, использовать острое сверло и просверлить с незначительным давлением!
- PL Używać podkładkę z drewna!
Docisnąć front, użyć ostrego wiertła i przewiercić, używając małej siły nacisku!
- H Alkalmazzon fa alátétet!
Nyomja le az előlapot, használjon éles fúrót, és kis nyomással fúrja át!
- CZ Použijte dřevěný podklad!
Přitlačte čelo, použijte ostrý vrták a prověřte pomocí malého tlaku!
- SLO Uporabite leseno podlago!
Pritisnite ličnico ter z ostrim svedrom in z majhnim pritiskom izvrtajte luknjo!
- FIN Käytä puualustaa!
Paina etulevy paikoilleen, käytä terävää poranterää ja poraa reikä vain kevyesti painamalla!
- S Använd ett träunderlag!
Tryck fronten mot underlaget, använd vass borr och borra igenom med ett lätt tryck!
- SK Použite drevený podklad!!
Pritlačte front, použite ostrý vrták a prevrtajte miernym tlakom!
- RO suport de lemn! Împingeți frontul, utilizați un burghiu ascuțit și perforați exercitând doar o presiune redusă!
- TR Ahşap taban kullanın!
Önden bastırın, keskin matkap ucu kullanın ve az basınç uygulayarak delin!

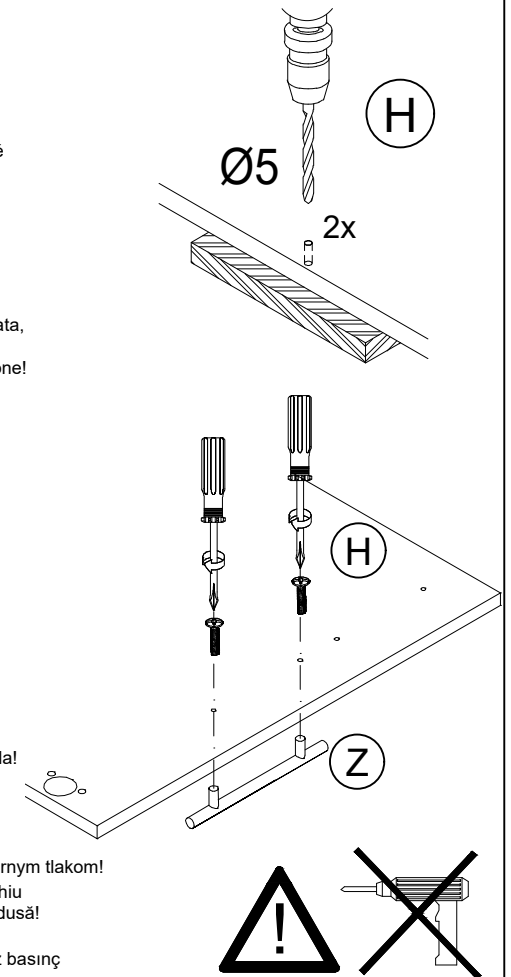

OPTI FIT

JAKA-BKL GmbH
Jaka Straße 3
D-32351 Stemwede-Wehden

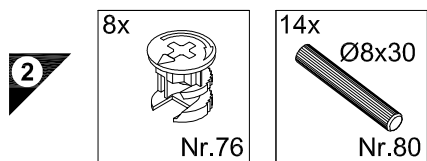
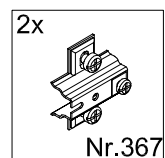
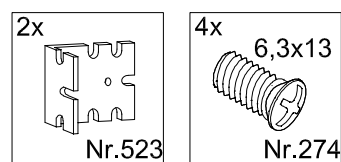
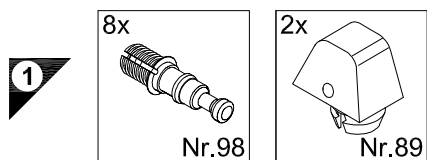
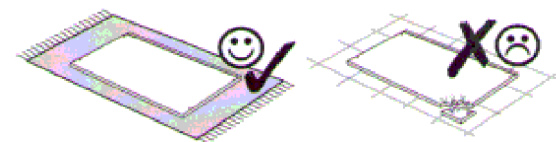
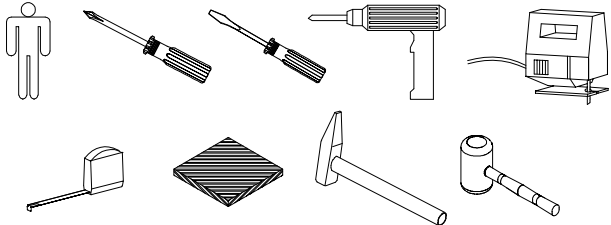

Service-Hotline
01805-678101
0,14€ pro Minute
++49 für Österreich
Auslandstarif pro Minute
service@jaka-bkl.de
voor Nederland en België
00800-40119350
benelux@jaka-bkl.de

Montageanleitung

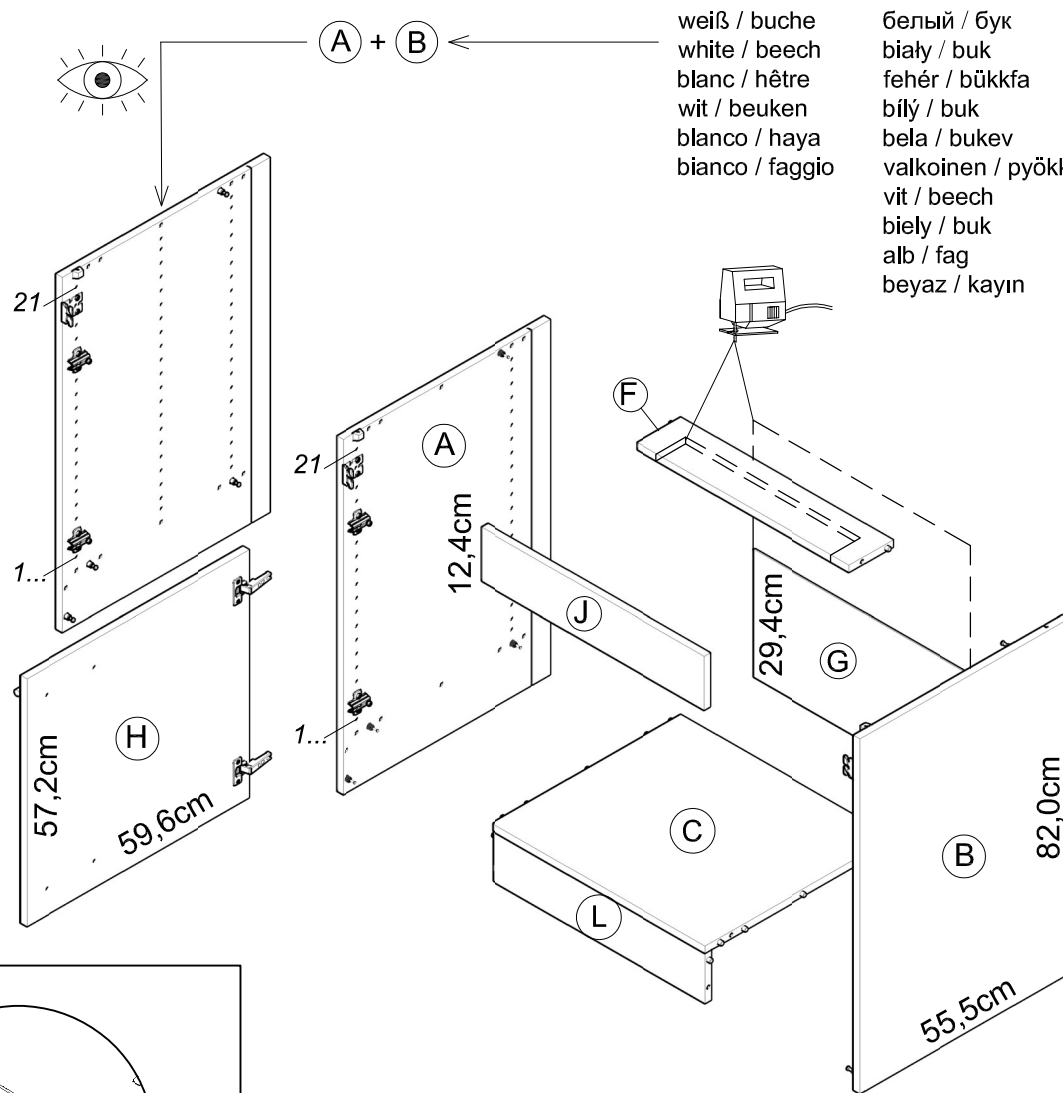
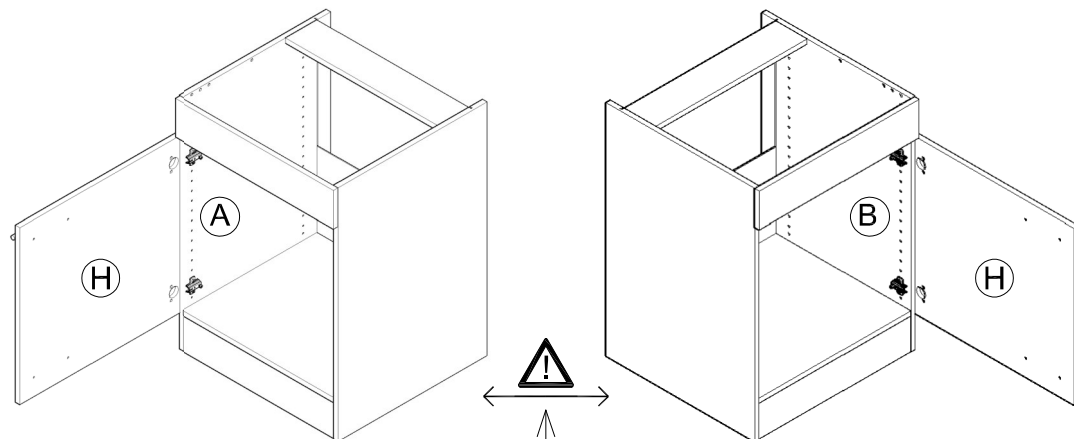
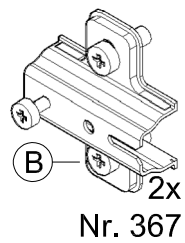
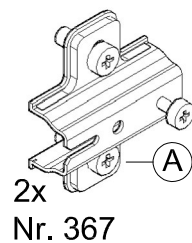
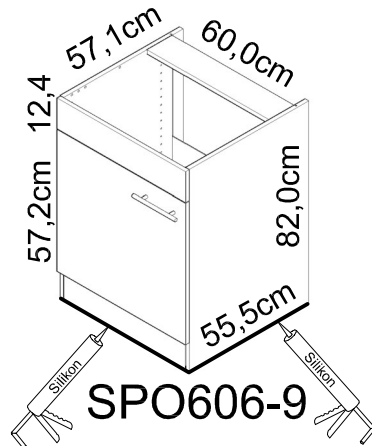

weiß / buche
white / beech
blanc / hêtre
wit / beuken
blanco / haya
bianco / faggio

белый / бук
biały / buk
fehér / bükkfa
bílý / buk
bela / bukev
valkoinen / pyökki
vit / beech
biely / buk
alb / fag
beyaz / kayın

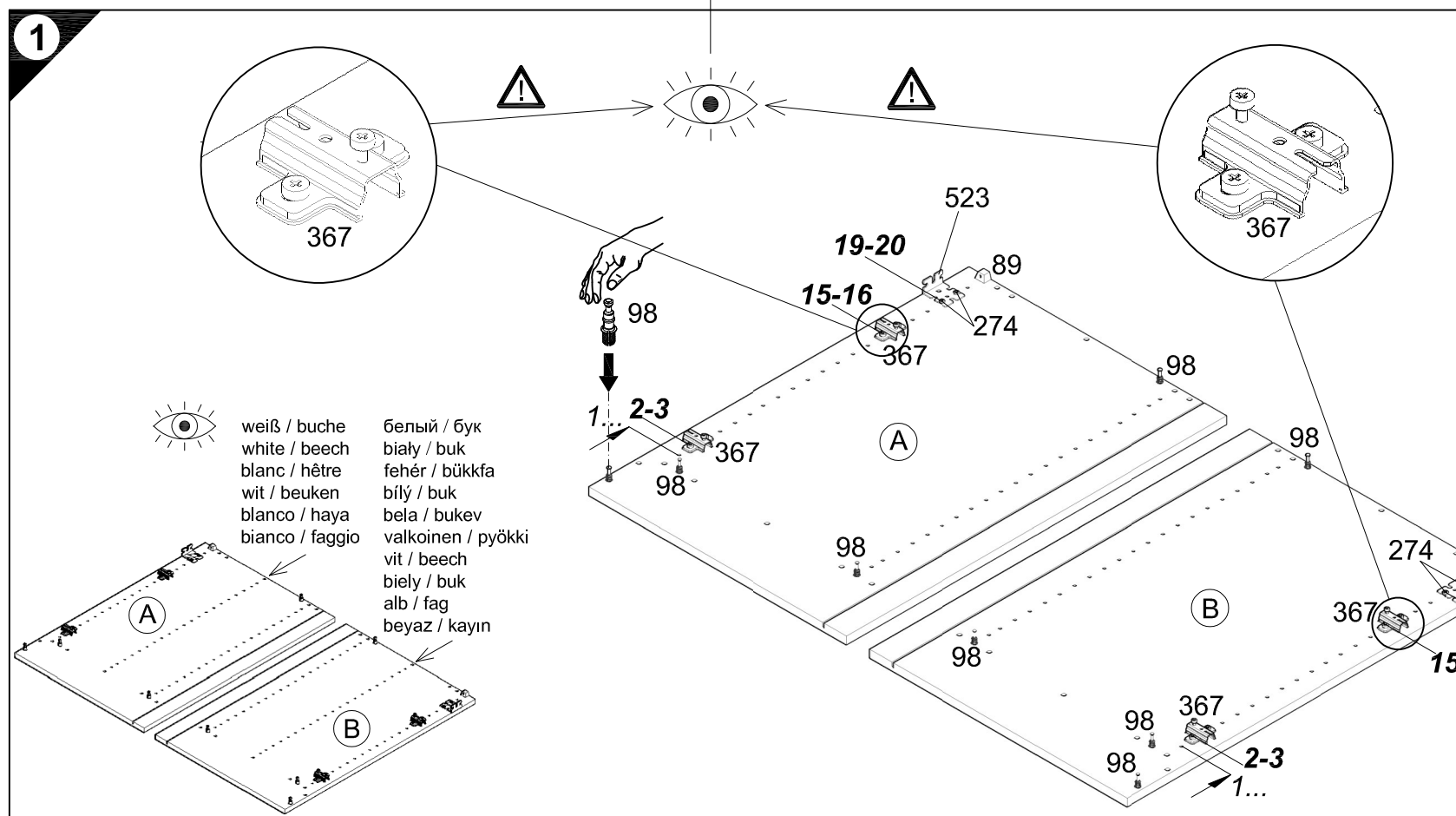

weiß / buche
white / beech
blanc / hêtre
wit / beuken
blanco / haya
bianco / faggio

белый / бук
biały / buk
fehér / bükkfa
bílý / buk
bela / bukev
valkoinen / pyökki
vit / beech
biely / buk
alb / fag
beyaz / kayın

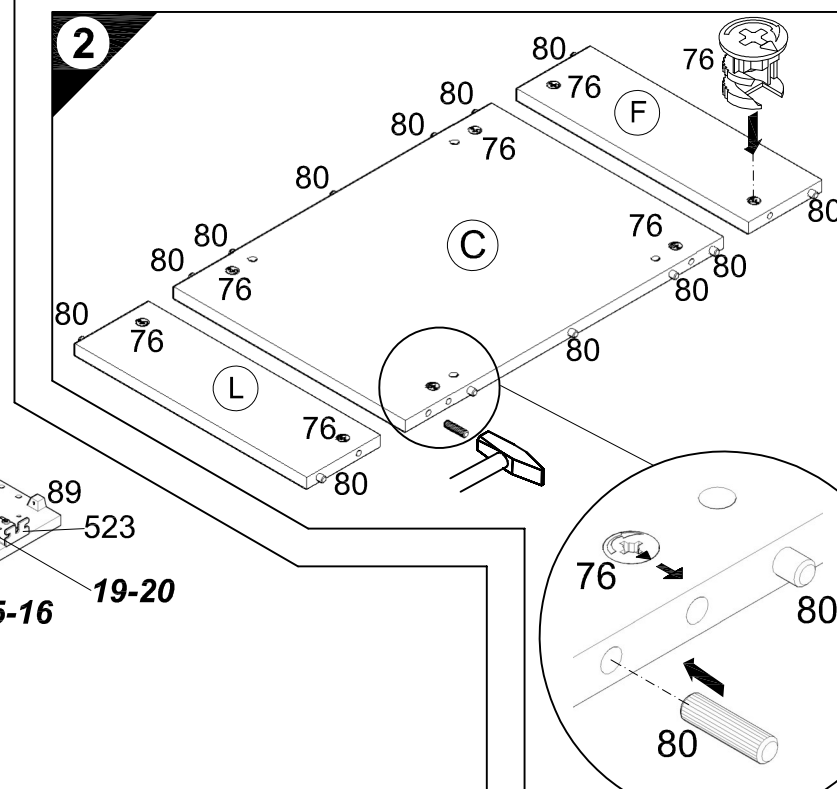

Ersatzteile/Spare parts/pièces de rechange/Reserveonderdelen/Piezas de recambio/Ricambi/Запасные части/Części zamienne/pótalkatrészek/Náhradní části/Nadomestni deli/varaosat/reservdelar/náhradné diely/Utilizați piese de schimb/Yedek parçalar

60cm SPO606-9 | [A] E961021 | [B] E961022 | [C] E954223 | [F] E970973 | [G] E970092 | [H] E940611 | [J] E940562 | [L] E970973
weiß/buche SPO606-9 | [A] E981021 | [B] E981022 | [C] E954223 | [F] E970973 | [G] E970092 | [H] E940611 | [J] E940562 | [L] E970973
white/beech.....

- 5** 16x
Nr.204
- 6** 2x
Nr.365
- 8** 4x 4x15
Nr.336
- 9** 2x 4x30
Nr.424
- 10** 4x 4x30
Nr.164

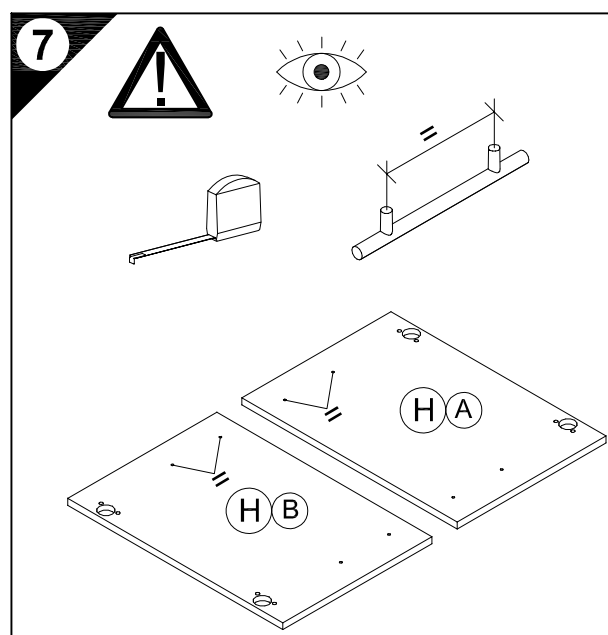
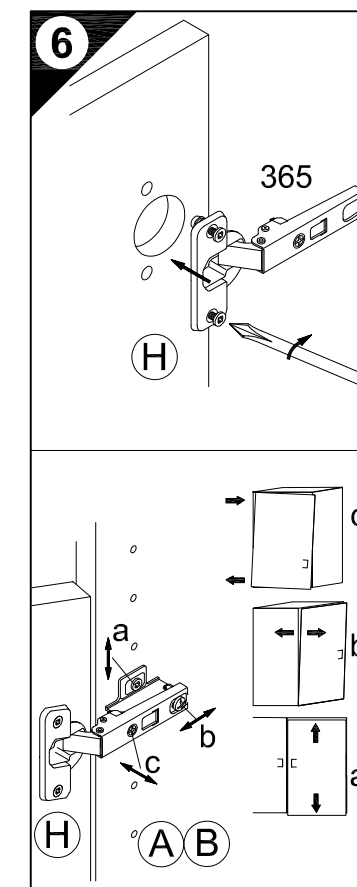
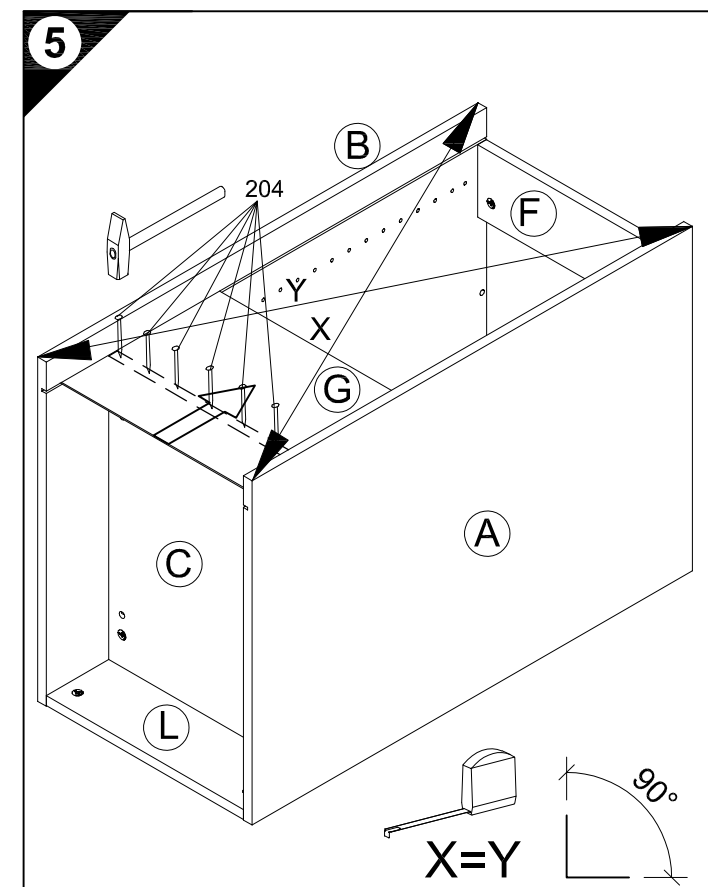
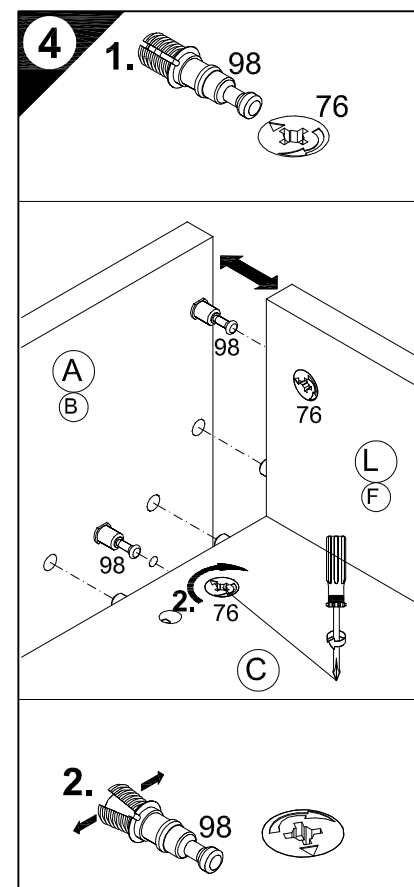
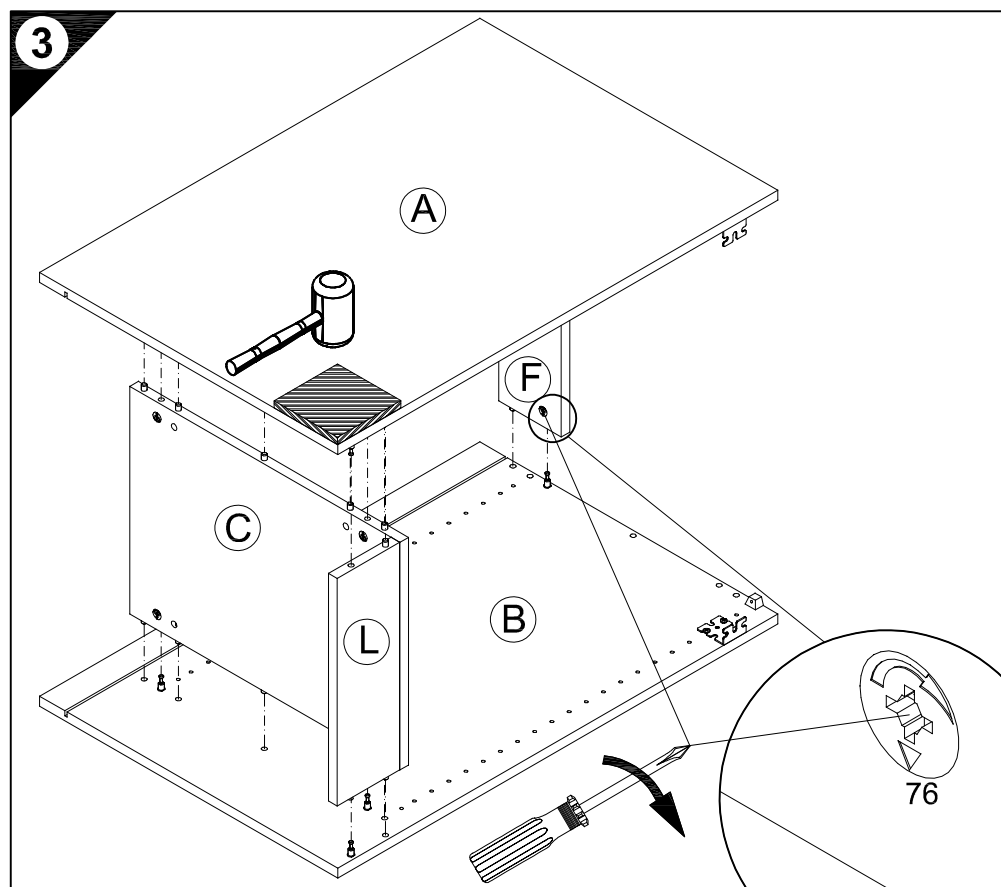

- D** Holzunterlage verwenden!
Front andrücken, scharfen Bohrer verwenden und mit wenig Druck durchbohren!
- GB** Use a wooden base!
Press front down, use sharp drill bit and, by applying slight pressure, drill a hole
- F** Utiliser un support en bois !
Appuyer sur la façade, utiliser un foret bien affûté et percer en appliquant une faible pression !
- NL** Houten onderlegger gebruiken!
Druk het front aan, gebruik een scherpe boor en oefen bij het boren weinig druk uit!
- E** ¡Utilizar una base de madera!
¡Presionar el frente, utilizar una broca afilada y taladrar con poca presión!
- I** Utilizzare una base di legno!
Appoggiare la facciata, utilizzare una punta di trapano affilata e trapanare esercitando solo una leggera pressione!
- RUS** Использовать деревянную подложку!
Прижать фасад, использовать острое сверло и просверлить с незначительным давлением!
- PL** Używać podkładkę z drewna!
Docisnąć front, użyć ostrego wiertła i przewiercić, używając małej siły nacisku!

- H** Alkalmazzon fa alátétet!
Nyomja le az előlapot, használjon éles fúrót, és kis nyomással fúrja át!
- CZ** Použijte dřevěný podklad!
Přitlačte čelo, použijte ostrý vrták a provrtajte pomocí malého tlaku!
- SLO** Uporabite leseno podlago!
Pritisnite ličnico ter z ostrim svedrom in z majhnim pritiskom izvrtajte luknjo!
- FIN** Käytä puualustaa!
Paina etulevy paikoilleen, käytä terävää poranterää ja poraa reikä vain kevyesti painamalla!
- S** Använd ett träunderlag!
Tryck fronten mot underlaget, använd vass borrh och borra igenom med ett lätt tryck!
- SK** Použite drevený podklad!!
Přitlačte front, použite ostrý vrták a prevrtajte miernym tlakom!
- RO** suport de lemn! Împingeți frontul, utilizați un burghiu ascuțit și perforați exercitând doar o presiune redusă!
- TR** Ahşap taban kullanın!
Önden bastırın, keskin matkap ucu kullanın ve az basınç uygulayarak delin!

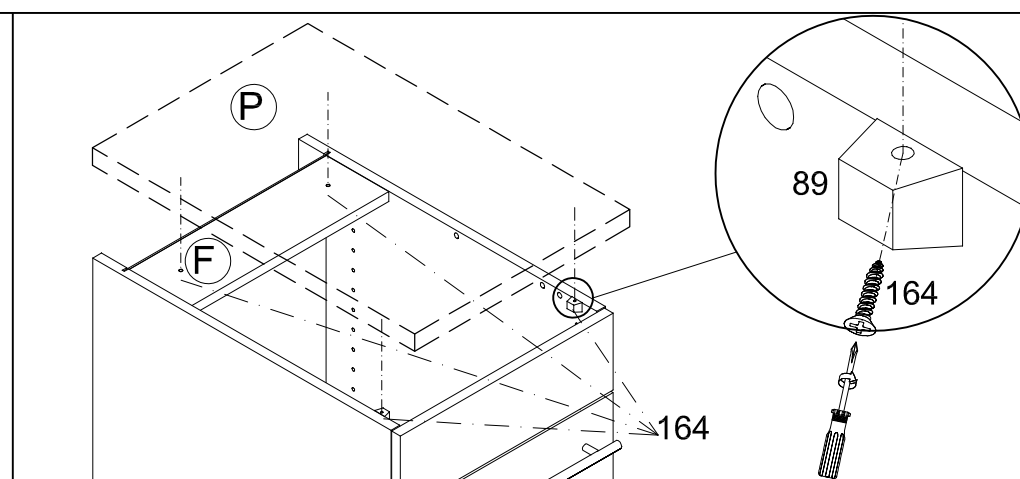
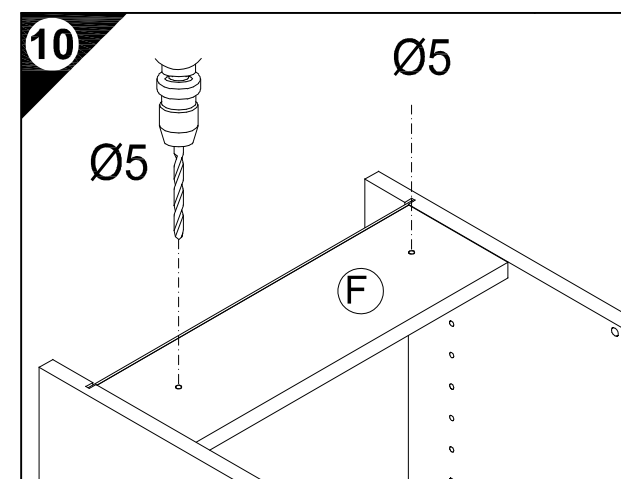
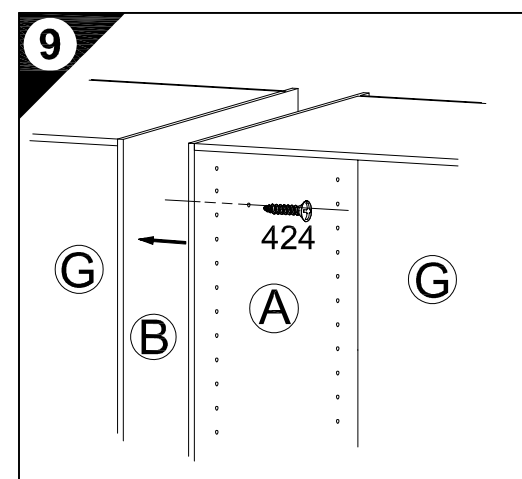
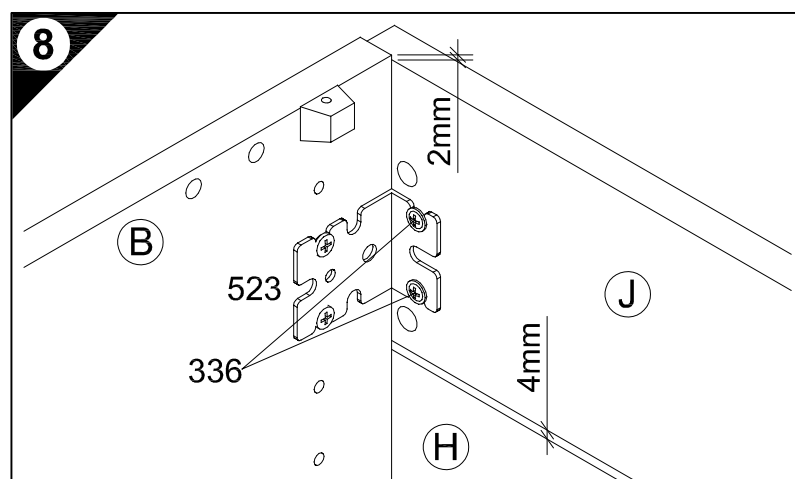
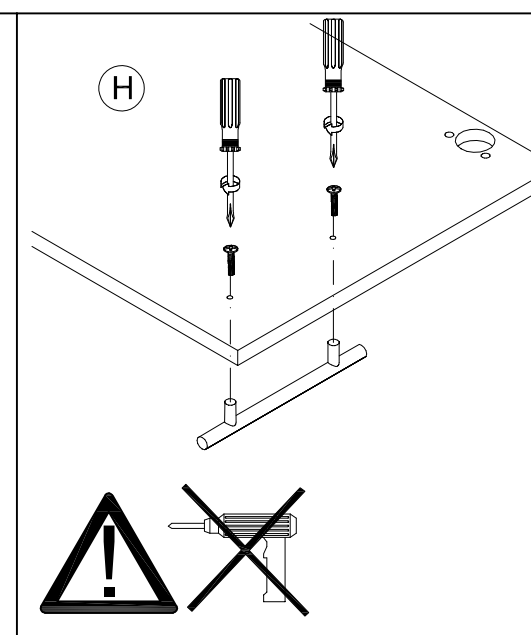
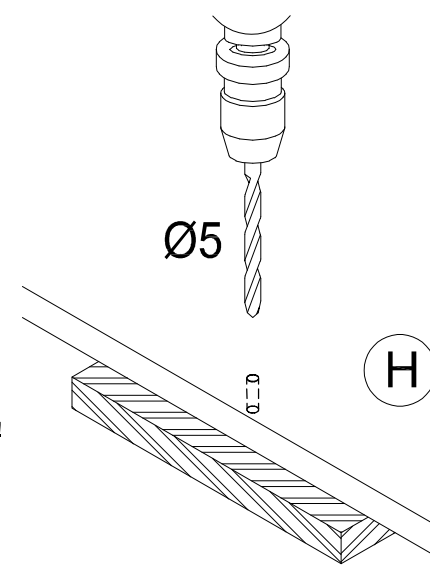

OPTI FIT

JAKA-BKL GmbH
Jaka Straße 3
D-32351 Sternweide-Wehden

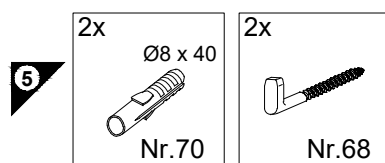
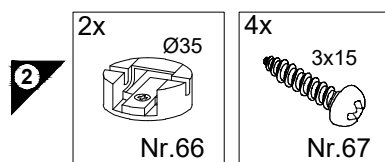
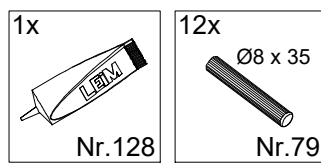
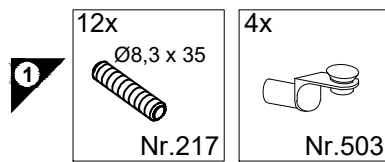
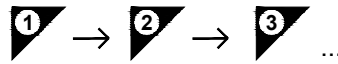
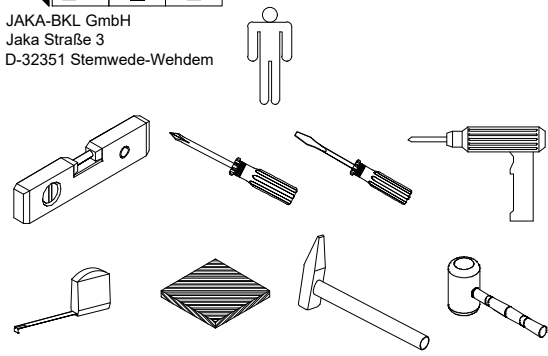

4x OR657+
D Nr.502

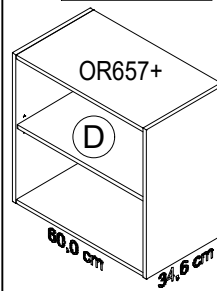

Version 1

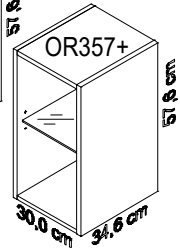
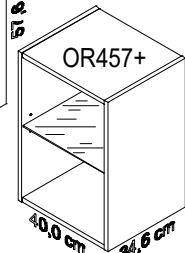
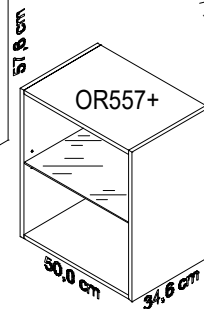

Service-Hotline
01805-678101
0,14€ pro Minute
++49 für Österreich
Auslandstarif pro Minute
service@jaka-bkl.de
voor Nederland en België
00800-40119350
benelux@jaka-bkl.de

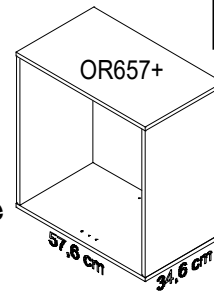

Version 2

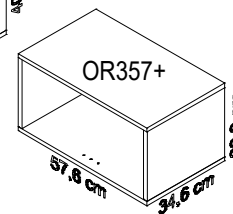
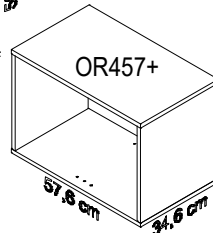
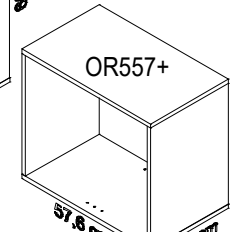

Montageanleitung

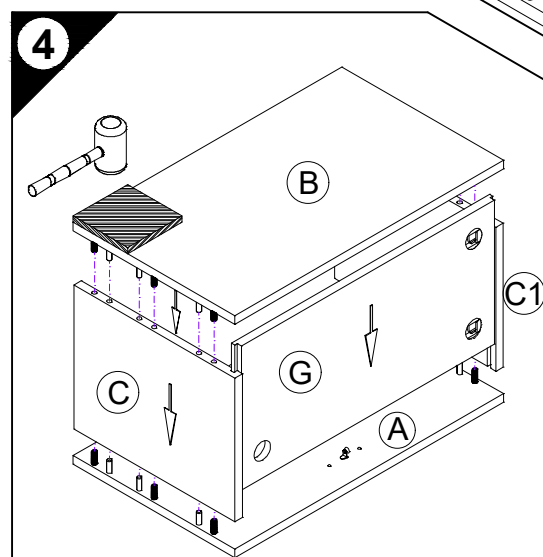
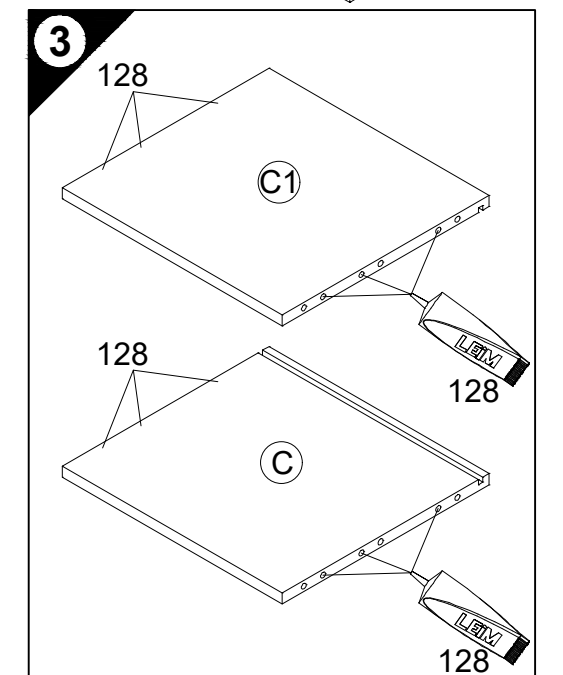
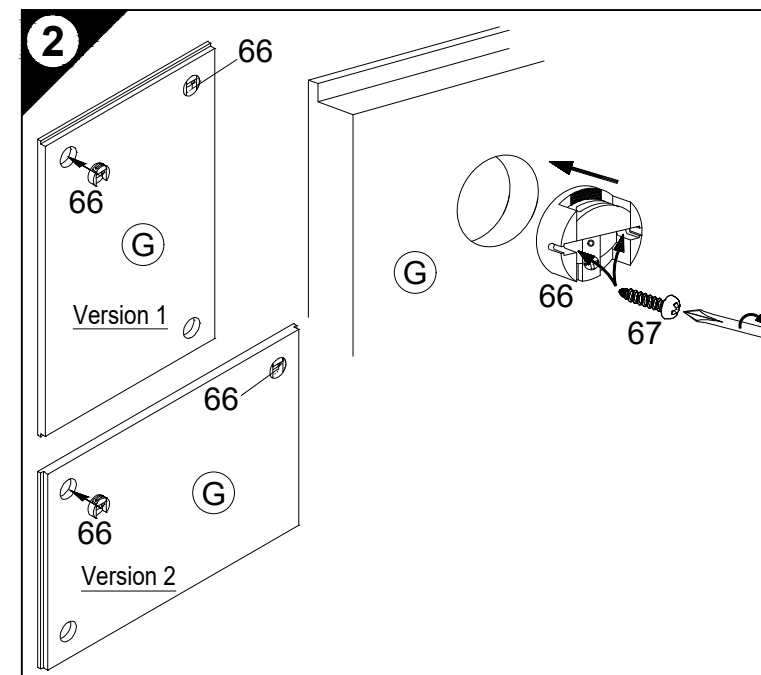
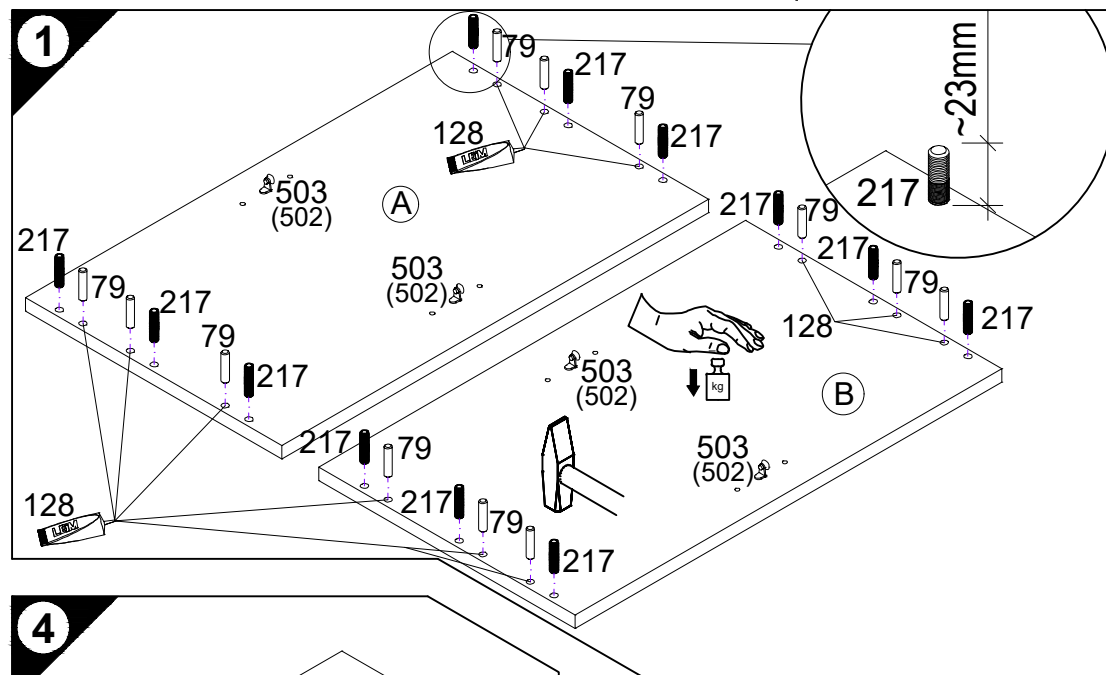
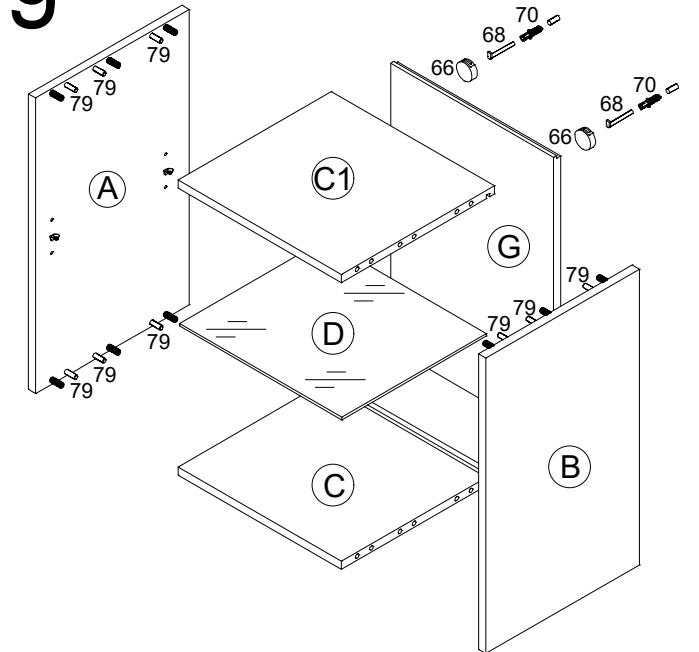

5

D Untergrund und Befestigungsmittel auf Eignung prüfen!
GB Check substructure and fixings for suitability!
F Contrôler si le support et les moyens de fixation sont bien adéquats !
NL Ondergrond en bevestigingsmateriaal op functionaliteit controleren!
E ¡Comprobar el suelo y los medios de fijación en cuanto a su aptitud!
I Controllare l'idoneità del fondo e del materiale di fissaggio!
RUS Основание и крепежный материал проверить на пригодность!
PL Podłoże oraz materiały do zamocowania sprawdzić na ich przydatność!
H Az alapelületet és a rögzítő anyagokat megfelelőség szempontjából ellenőrizni kell!
CZ Přezkoušejte podklad a vhodnost upevňovacích prostředků!
SLO Preverite, če se ujemajo spodnja stran in pritrilna sredstva!
FIN Tarkista alustan ja kiinnitysvälineiden sopivuus!
S Kontrollera att underlaget och fästmedlen är lämpliga!
SK Preverte vhodnosť podkladu a upevňovacích prostriedkov!
RO Verificați caracterul adecvat al suprafeței suport și al mijloacelor de fixare!
TR Zeminin ve bağlantı elemanlarının uygunluğunu kontrol edin!

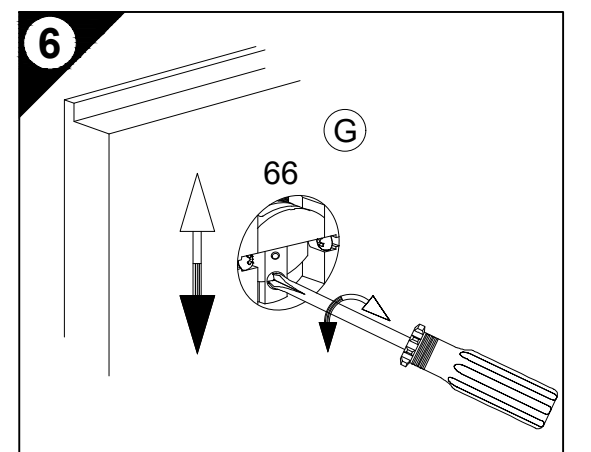

Ersatzteile/Spare parts/pièces de rechange/Reserveonderdelen/Piezas de recambio/Ricambi/Запасные части/Części zamienn/pótalkatrészek/Náhradní části/Nadomestni deli/varaosat/reservdelar/náhradné diely/piese de schimb/yedek parçalar

OR357+	A E940052	B E940052	C E940141	C1 E940141	D E946663	G E940110	OR657+	A E940052	B E940052	C E941252	C1 E941252	D E940321	G E940165
OR457+	A E940052	B E940052	C E941250	C1 E941250	D E946658	G E940092							
OR557+	A E940052	B E940052	C E941251	C1 E941251	D E946659	G E940089							

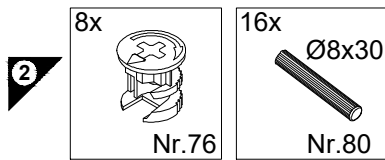
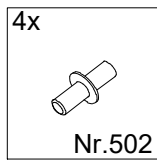
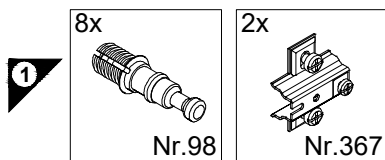
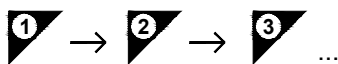
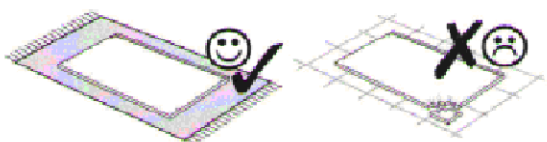
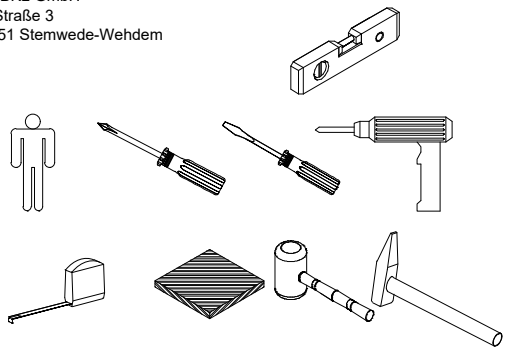

Service-Hotline
01805-678101
0,14€ pro Minute
++49 für Österreich
Auslandstarif pro Minute
service@jaka-bkl.de
voor Nederland en België
00800-40119350
benelux@jaka-bkl.de

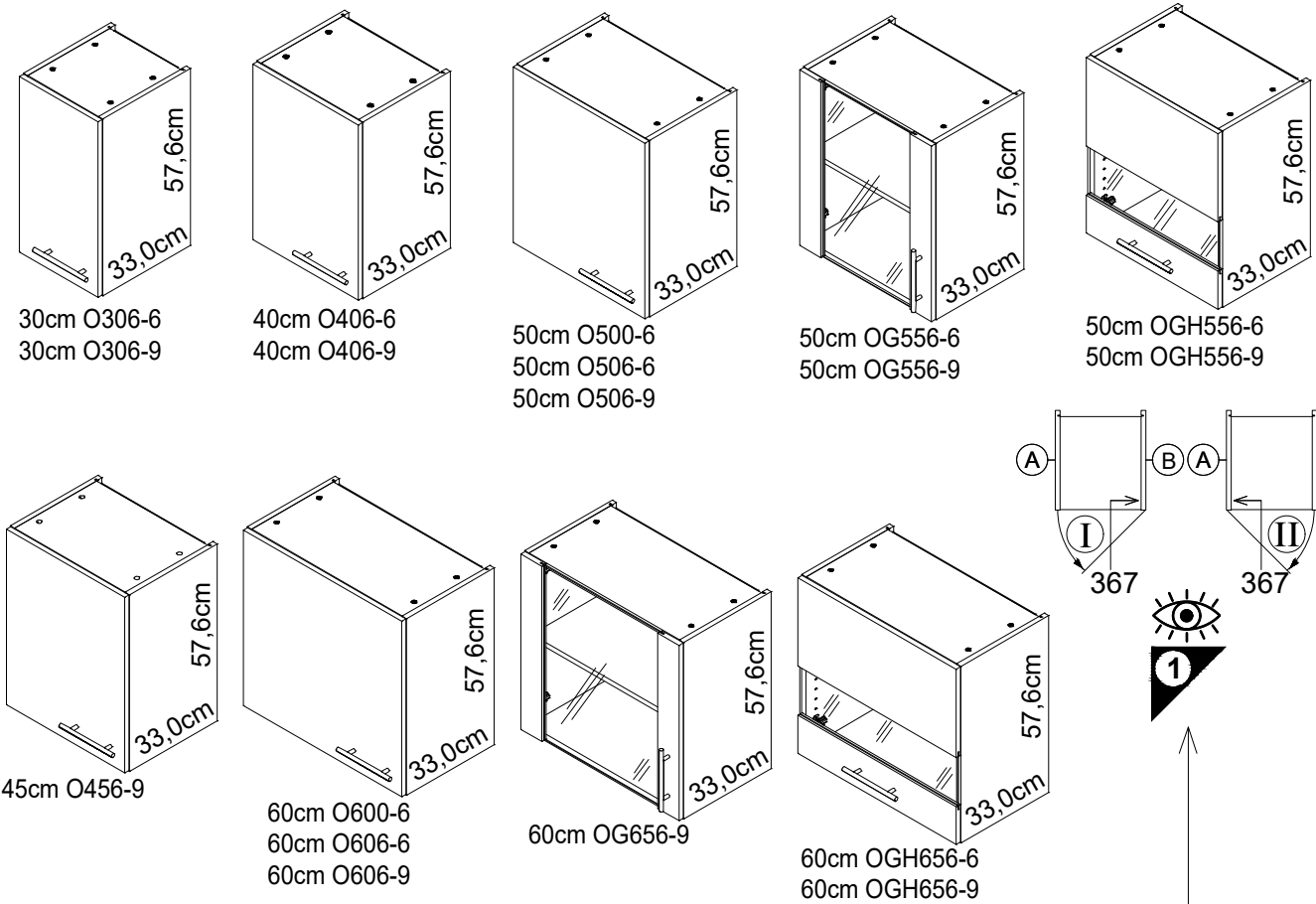

Montageanleitung

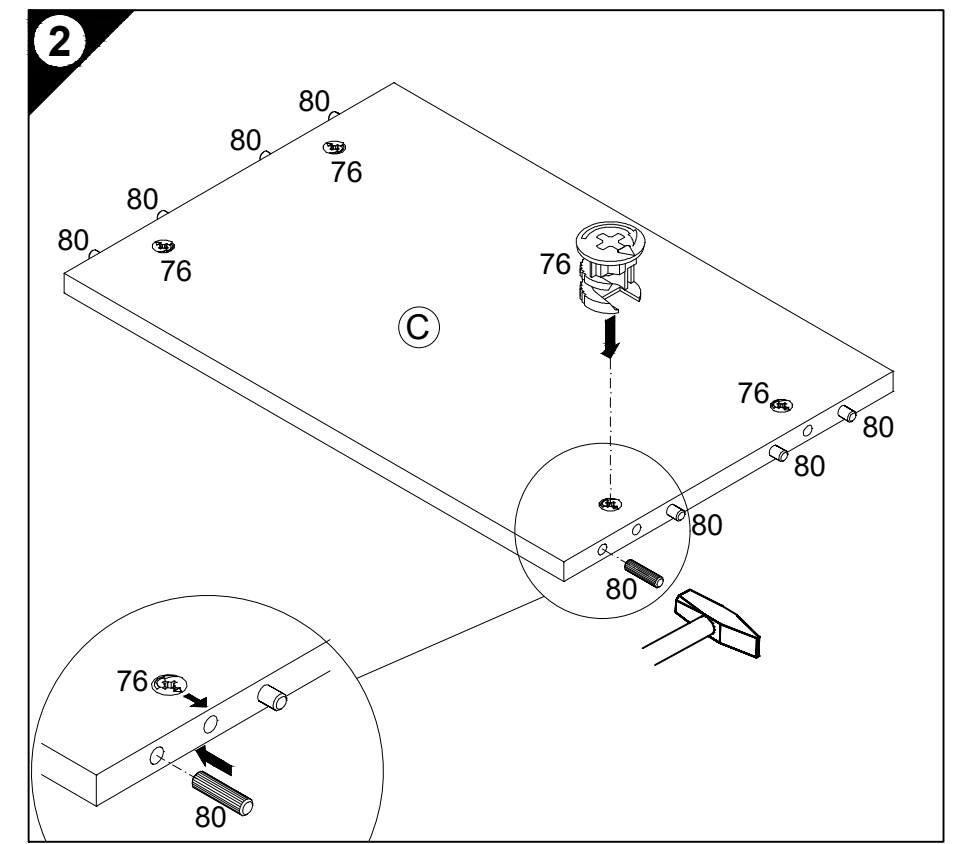
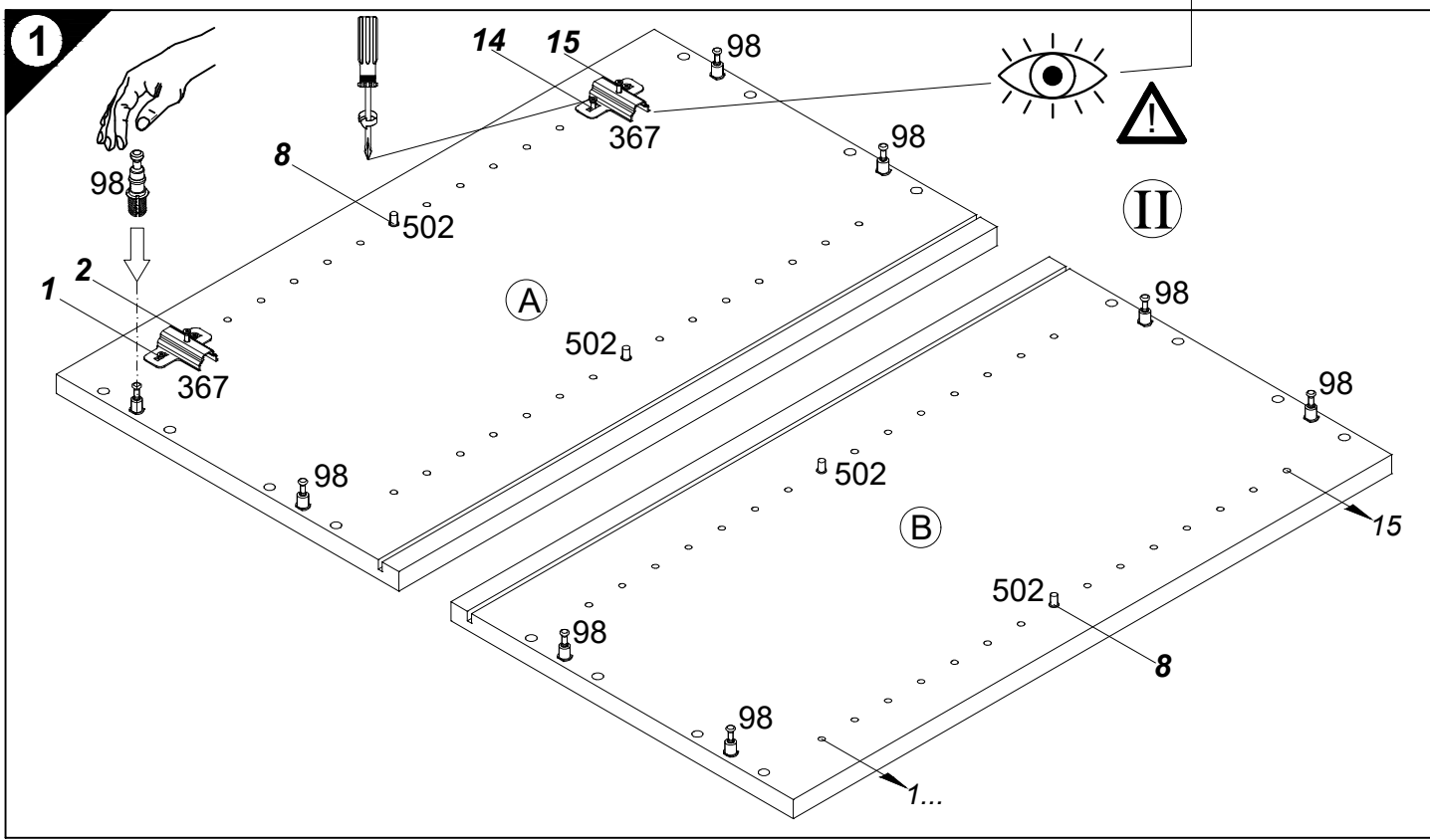
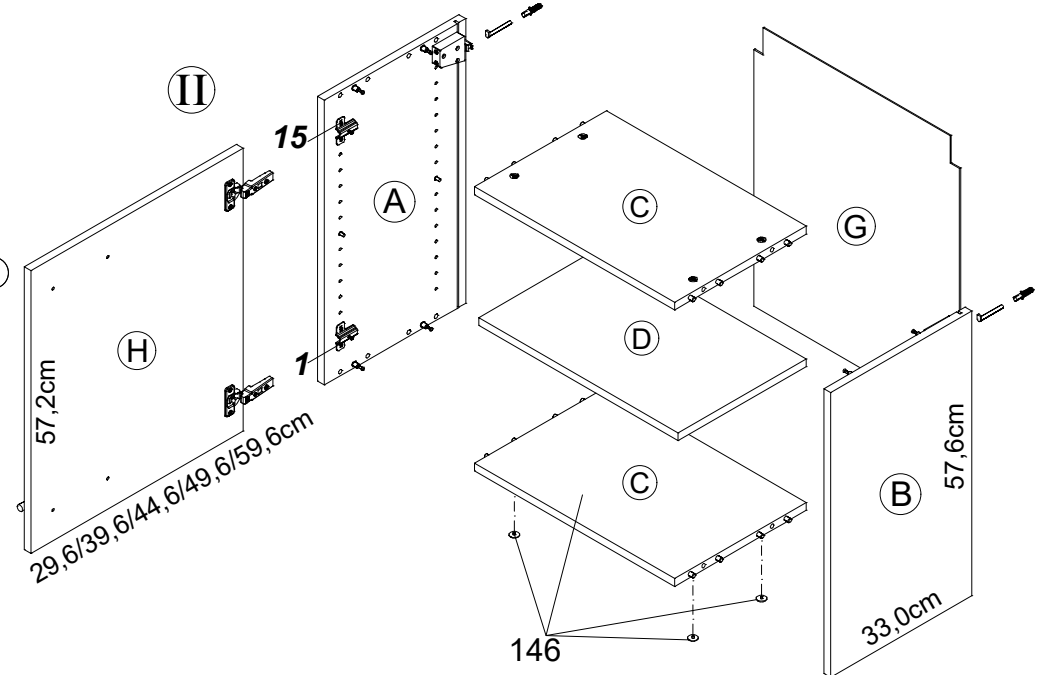

Ersatzteile/Spare parts/pièces de rechange/Reserveonderdelen/Piezas de recambio/Ricambi/Запасные части/Części zamienne/pótkatárszek/Náhradní části/Nadomestni deli/varaosat/reservdelar/náhradné diely/Utilizați piese de schimb/Yedek parçalar

30cm O306-6/ -9	A E940036	B E940036	C E941236	D E940336	G E971015	H E940614	50cm OG556-6/ -9	A E940036	B E940036	C E941234	D E940334	G E970032	H E940647
40cm O406-6/ -9	A E940036	B E940036	C E941235	D E940335	G E971014	H E940613	50cm OGH556-6/ -9	A E940036	B E940036	C E941234	D E940334	G E970032	H E940655
45cm O456-9	A E940036	B E940036	C E941237	D E940337	G E971013	H E940616	60cm OGH656-6/ -9	A E940036	B E940036	C E941233	D E940333	G E971012	H E980657
50cm O500	A E940036	B E940036	C E941234	D E940334	G E970032	H E980612	60cm OG656-9	A E940036	B E940036	C E941233	D E940333	G E971012	H E940657
50cm O506-6/ -9	A E940036	B E940036	C E941234	D E940334	G E970032	H E940612							
60cm O600	A E940036	B E940036	C E941233	D E940333	G E971012	H E980611							
60cm O606-6/ -9	A E940036	B E940036	C E941233	D E940333	G E971012	H E940611							

1 → 2 → 3 ...

- 3 4x
Ø18/Ø4
Nr.146
- 4 2x
Nr.277
- 6x
4x30
Nr.164
- 5 10x
Nr.204
- 7 2x
Nr.365
- 2x OGH...
Nr.107
- 9 2x
Ø8x40
Nr.70
- 2x
Nr.69
- 10 2x
4x30
Nr.424

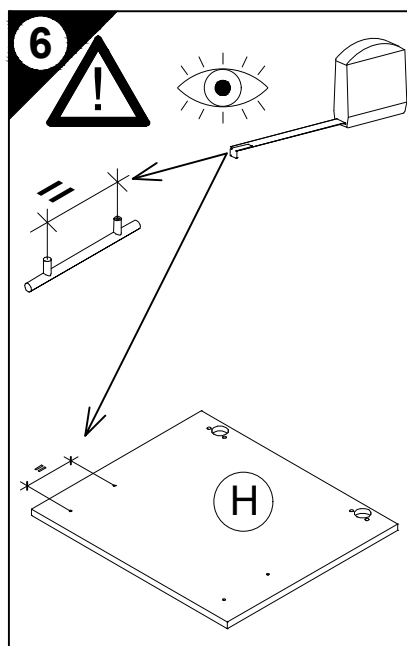
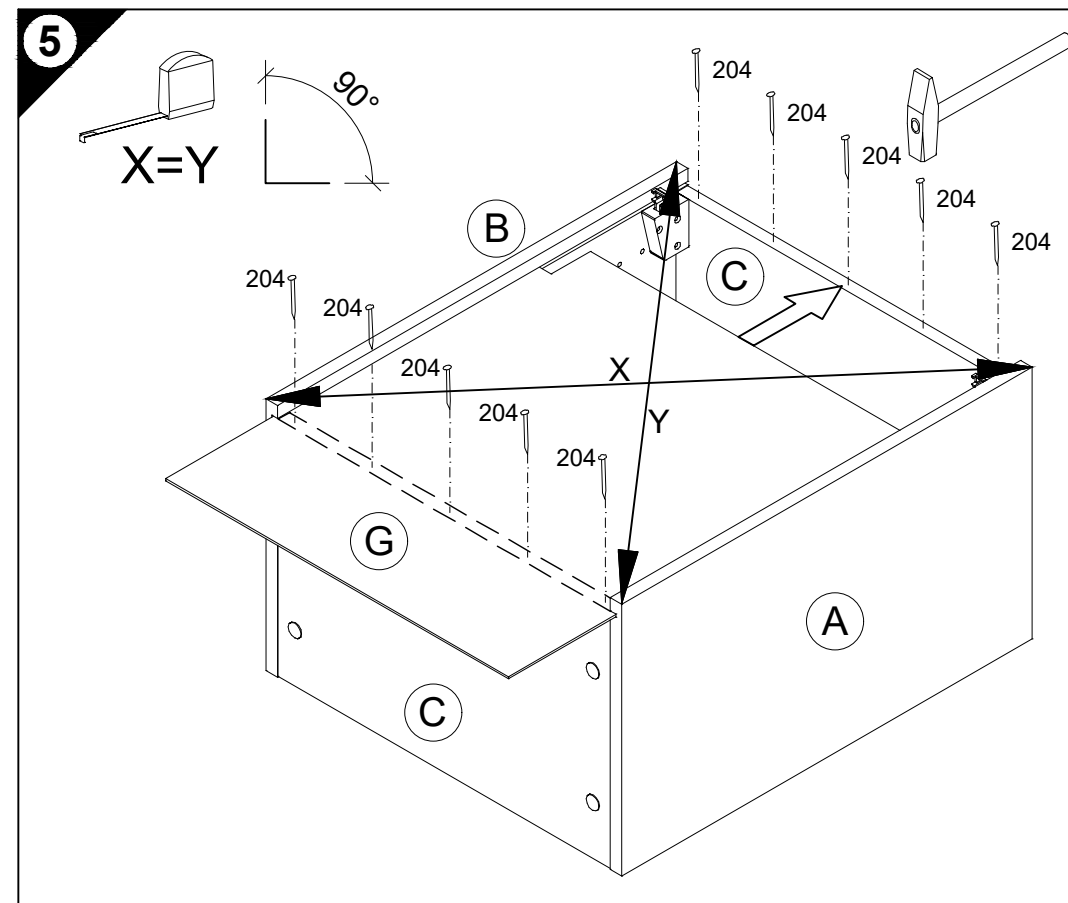
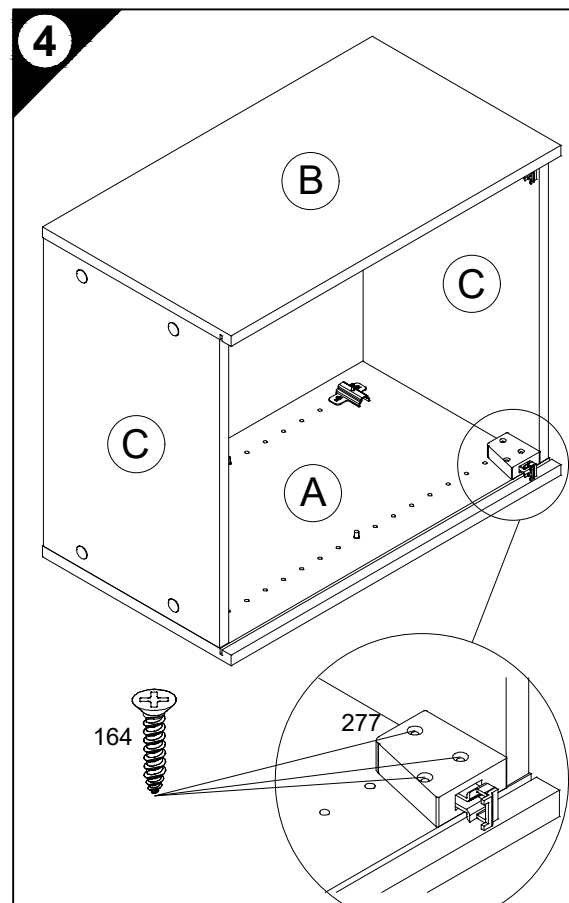
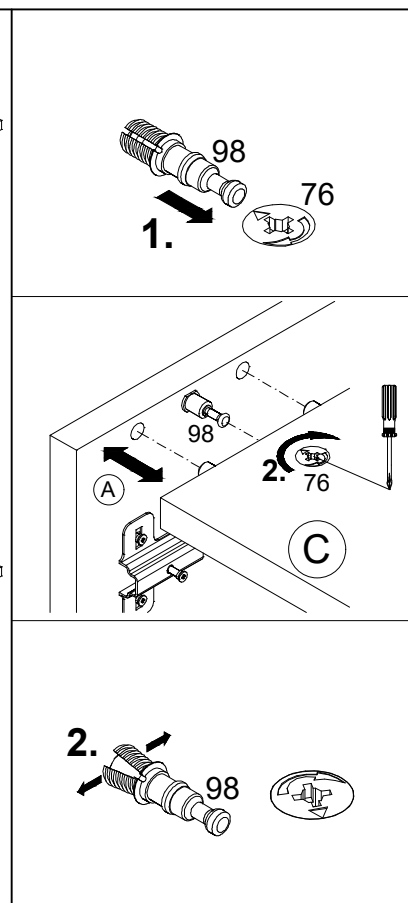
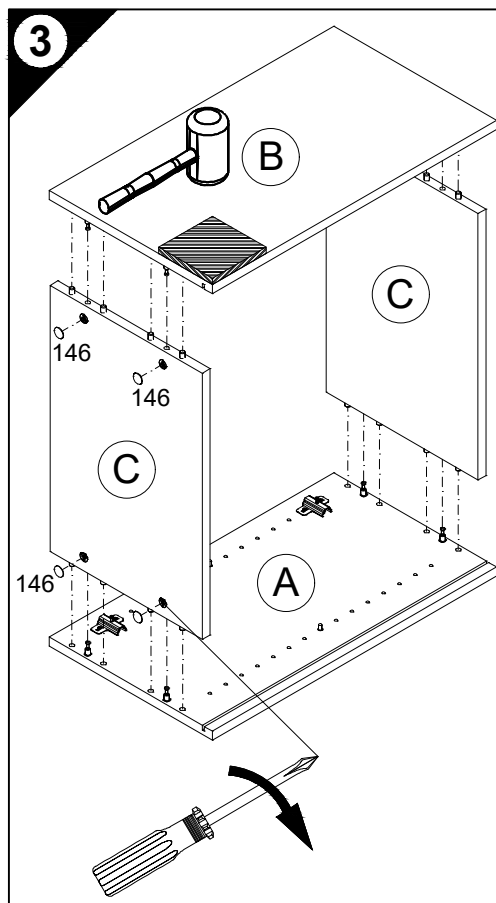

D Holzunterlage verwenden!
Front andrücken, scharfen Bohrer verwenden und mit wenig Druck durchbohren!

GB Use a wooden base!
Press front down, use sharp drill bit and, by applying slight pressure, drill a hole

F Utiliser un support en bois !
Appuyer sur la façade, utiliser un foret bien affûté et percer en appliquant une faible pression !

NL Houten onderlegger gebruiken!
Druk het front aan, gebruik een scherpe boor en oefen bij het boren weinig druk uit!

E ¡Utilizar una base de madera!
¡Presionar el frente, utilizar una broca afilada y taladrar con poca presión!

I Utilizzare una base di legno!
Appoggiare la facciata, utilizzare una punta di trapano affilata e trapanare esercitando solo una leggera pressione!

RUS Использовать деревянную подложку!
Прижать фасад, использовать острое сверло и просверлить с незначительным давлением!

PL Używać podkładkę z drewna!
Docisnąć front, użyć oстрego wiertła i przewiercić, używając małej siły nacisku!

H Alkalmazzon fa alátétet!
Nyomja le az előlapot, használjon éles fúrót, és kis nyomással fúrja át!

CZ Použijte dřevěný podklad!
Přitlačte čelo, použijte ostrý vrták a provřtejte pomocí malého tlaku!

SLO Uporabite leseno podlago!
Pritisnite ličnico ter z ostrim svedrom in z majhnim pritiskom izvrtajte luknjo!

FIN Käytä puualustaa!
Paina etulevy paikoilleen, käytä terävää poranterää ja poraa reikä vain kevyesti painamalla!

S Använd ett träunderlag!
Tryck fronten mot underlaget, använd vass borrh och borra igenom med ett lätt tryck!

SK Použite drevený podklad!
Přitlačte front, použite ostrý vrták a prevřtajte miernym tlakom!

RO suport de lemn!
Împingeți frontul, utilizați un burghiu ascuțit și perforați exercitând doar o presiune redusă!

TR Ahşap taban kullanın!
Önden bastırın, keskin matkap ucu kullanın ve az basınç uygulayarak delin!

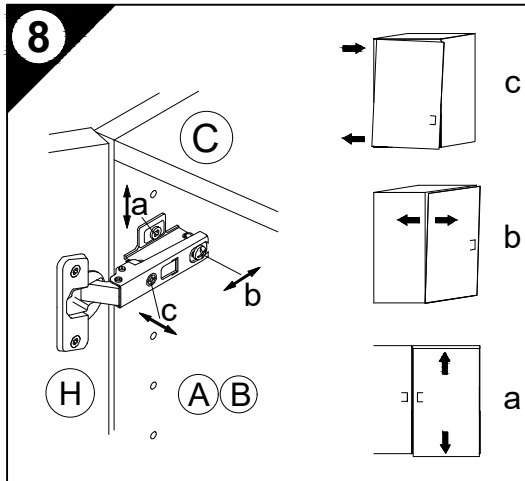
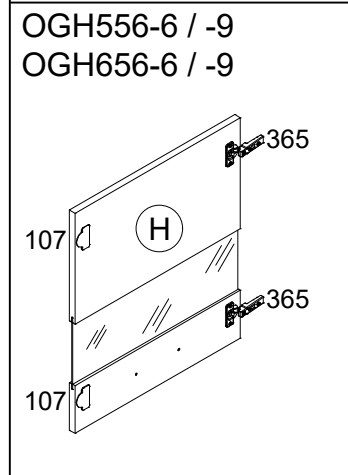
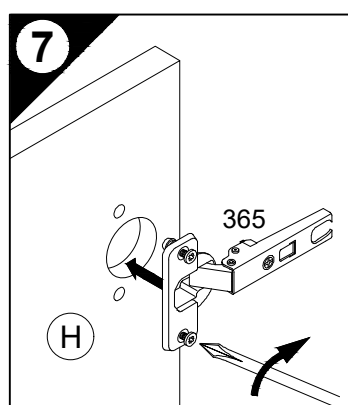
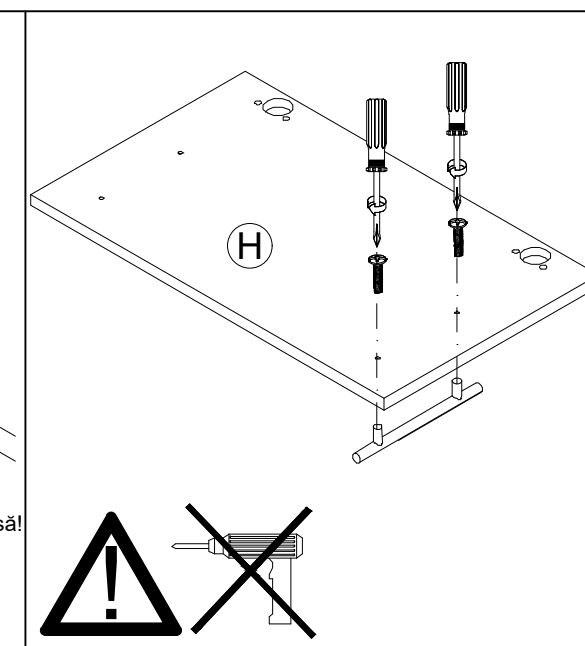
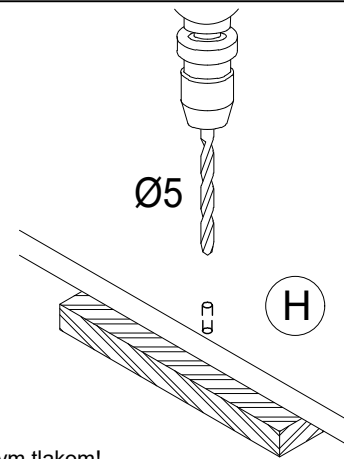

9 D Untergrund und Befestigungsmittel auf Eignung prüfen!
GB Check substructure and fixings for suitability!
F Contrôler si le support et les moyens de fixation sont bien adéquats !
NL Ondergrond en bevestigingsmateriaal op functionaliteit controleren!
E ¡Comprobar el suelo y los medios de fijación en cuanto a su aptitud!
I Controllare l'idoneità del fondo e del materiale di fissaggio!
RUS Основание и крепежный материал проверить на пригодность!
PL Podłoże oraz materiały do zamocowania sprawdzić na ich przydatność!
H Az alapelületet és a rögzítő anyagokat megfelelőség szempontjából ellenőrizni kell!
CZ Přeřkoušejte podklad a vhodnost upevňovacích prostředků!
SLO Preverite, če se ujemajo spodnja stran in pritrdilna sredstva!
FIN Tarkista alustan ja kiinnitysvälineiden sopivuus!
S Kontrollera att underlaget och fästmedlen är lämpliga!
SK Preverte vhodnosť podkladu a upevňovacích prostriedkov!
RO Verificați caracterul adecvat al suprafeței suport și al mijloacelor de fixare!
TR Zeminin ve bağlanı elemanlarının uygunluğunu kontrol edin!

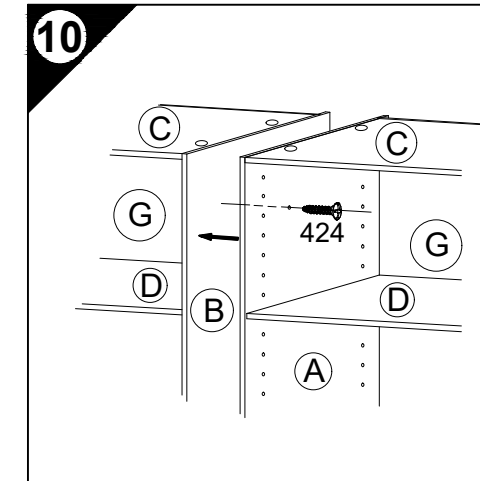
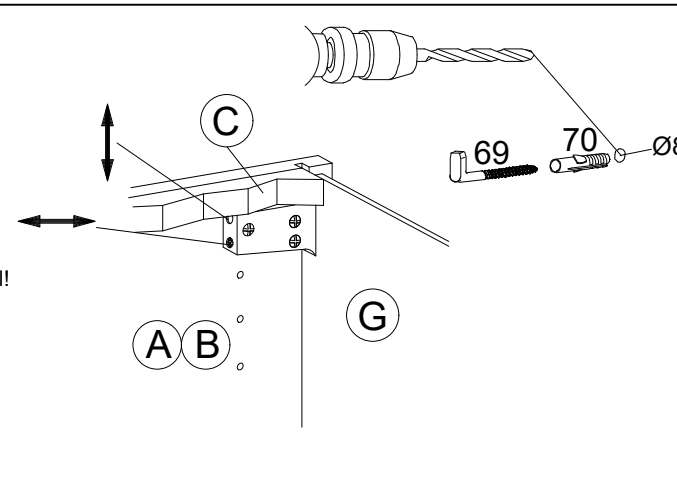

SERVICEKARTE

VH

Liebe Kundin, lieber Kunde,

obwohl wir unsere Möbel vor der Auslieferung einer eingehenden Endkontrolle unterziehen, kann es vorkommen, dass einmal ein Zubehörteil fehlt oder während des Transports beschädigt wird. Senden sie den Artikel bitte nicht zurück, sondern fordern sie einfach Ersatz für das Einzelteil bei unserer Kundenhotline an. Die Telefonnummern finden sie auf den Serviceseiten im Katalog.

Bitte benennen sie die Teile wie sie auf ihrer Aufbauanleitung angegeben sind. Fügen sie auch **Artikelnummer, Modellnamen und Farbnummer** bei. **Siehe Beispiel.**

Wir werden ihre Anforderung sofort bearbeiten und ihnen das Ersatzteil umgehend zusenden.

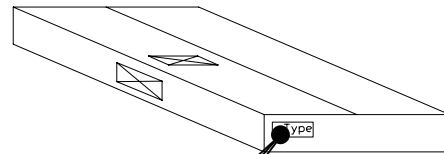
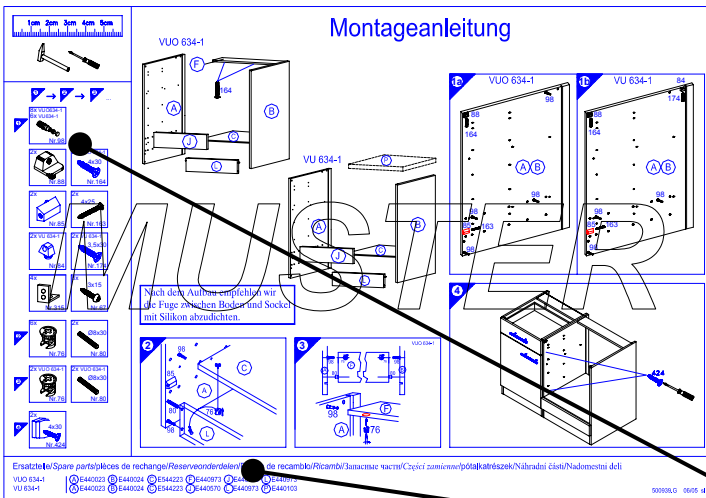

Muster - Bestellung		
Artikelnummer	123 456	
Modellname	Unterschrank VU634	
Farbe	TA 01	
Benötigte Ersatzteile:		
Bezeichnung	Nr.	Anzahl
Beschlagteil	98	2
Teil B	E 440 023	1

Bitte entnehmen sie die notwendige Ersatzteilnummer der Aufbauanleitung die zum Möbel gehört!

Kundendaten	
Kundennummer	
Name	
Vorname	
Strasse	
Haus-Nr.	
PLZ	
Ort	
Rechnungsdatum	
Tel. für Rückfragen	
Notizen:	

Ersatzteilbestellung		
Artikelnummer		
Modellname		
Farbe		
Benötigte Ersatzteile:		
Bezeichnung	Nr.	Anzahl
Grund der Ersatzteilanforderung:		

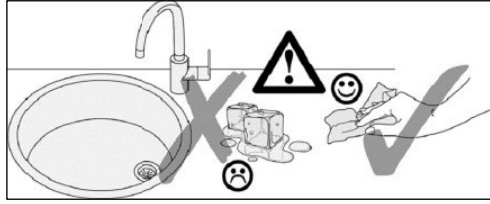
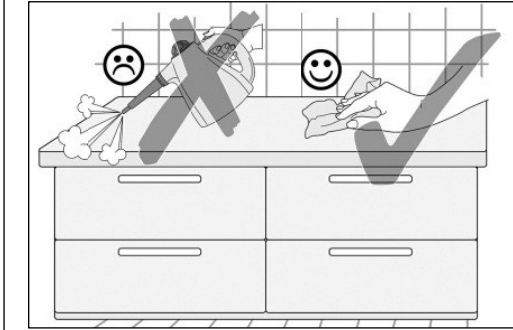

500823.1.A 04/15 sl

D Pflegehinweise

Kunststoff-Oberflächen: Kunststoffbeschichtete Oberflächen/Fronten lassen sich mit handelsüblichen Reinigungsmitteln pflegen. Am besten geht das mit einem weichen Tuch, handwarmen Wasser und etwas Spülmittel. Verwenden Sie keine polierenden Reinigungsmittel oder harte Schwämme! Hartnäckige Flecken, wie Fettspritzer, Lack- oder Klebstoffreste, sind mit einem handelsüblichen Kunststoffreiniger zu beseitigen. Vor dem ersten Gebrauch dieser Mittel empfiehlt es sich, diese an einer nicht sichtbaren Stelle zu prüfen!

Glänzende Fronten: Diese Fronten nie trocken reinigen!
Die Verwendung von schleifenden Reinigungsmitteln (Mikrofasertücher, Scheuerschwämme etc.) können zu erhöhter Bildung von Kratzern führen und sind kein Reklamationsgrund. Verwenden Sie daher am besten ein staubfreies Tuch oder ein feuchtes Fensterleder.

Einbauspülen und Herdmüden: Hartnäckige Verschmutzungen, Kalk- und Wasserflecken sowie glänzenden Topfblech besaßigen. Sie mit dem vom Hersteller empfohlenen Spezialreiniger (z.B. Cerafix, Stahlfix), fräsigbrannte Verkürstungen (Zucker, Salz oder zuckerhaltige Speisereste) entfernen Sie. In noch heißem Zustand, mit einem Glaschaber.

Beachten Sie hierzu auch die Bedienungsanleitung des Geräteherstellers!

Griffe: Verzichteten Sie auf lösungsmittelhaltige und aluminiumschädigende Substanzen sowie auf Essigreiniger, da diese zu einer nicht mehr entfernbaren Fleckbildung führen können.

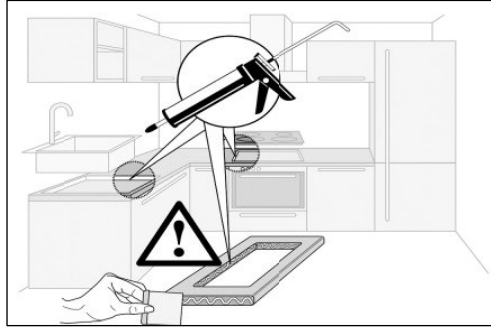
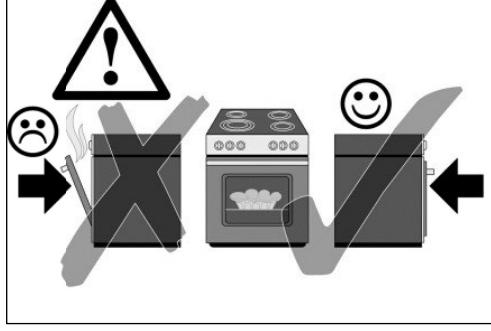
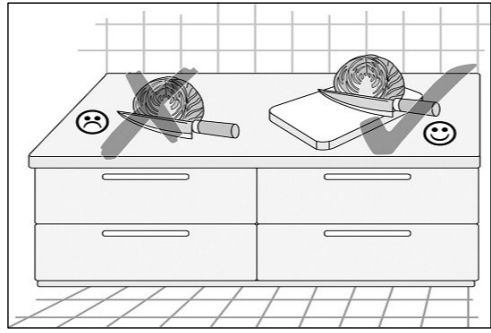

GB Care instructions

Synthetic Surfaces:

Synthetic finishes on surfaces/fronits can be cared for with common household cleaners. It's best to use a soft cloth, hand warm water and a little washing-up liquid. Do not use any polishing cleaners or hard sponges! Stubborn marks, such as grease splashes, paint or adhesive residues can be removed with common, commercially available synthetic materials cleaners. However, it is recommended that these be tested on an inconspicuous area before using them for the first time!

Gloss Fronts:

The use of abrasive cleaning materials (microfibre cloths, scrubbing sponges, etc.) can lead to increased incidence of surface scratching and are not accepted grounds for complaints. Therefore using a dustfree cloth or a damp chamomils is best.

Fitted Sink Units and Hobs:

Fitted sink units and all other articles made of stainless steel are best cleaned using a sponge or a fleece cloth with a washing-up liquid or known specialty cleaner (stainless steel cleaner, metal polish). Use mild washing-up or cleaning liquids on fitted sinks made of other materials, such as porcelain, synthetic material, acrylic ceramic as well as stainless steel. In addition, make sure to always follow the specific care instructions provided by the respective manufacturer!

Ceramic Glass Hobs:

Stubborn marks, limescale and water spots and stippy marks left

by pots are best removed with special cleaners as recommended by the manufacturer. Use a glass scraper to remove burn-on marks (sugar, salt or food splashes containing sugar) write soft hot.

Handles:

Avoid using substances containing solvents or which are harmful to aluminium, as well as cleaners containing vinegar, as these can cause permanent discoloration.

NL Onderhoudsinstructies

Kunststof-oppervlakken:

Oppervlakken/fronten met een kunststof coating kunnen met een gangbaar huishoudelijk reinigingsmiddel worden verzorgd. Dat gaat het beste met een zacht doekje, handwarm water en een beetje afwasmiddel. Gebruik geen polijstende reinigingsmiddelen of harde sponjes! Hardnekkige vlekken, resten van lak of lijn, moeten met een gangbaar reinigingsmiddel voor kunststof worden verwijderd. Voor het eerste gebruik van dit middel is het aan te bevelen om dit op een niet zichtbare plek uit te proberen!

Glänzende fronten:

Deze fronten nooit droog reinigen!
Het gebruik van schurende reinigingsmiddelen (microvezeldoekjes, schuursponjes etc.) kunnen tot snellere vorming van krassen leiden en zijn geen reden voor een reclamatie. Gebruik daarom het beste een stofrijt doekje of een vochtige zeem.

Inbouwgootstenen en kookplaten:

Inbouwgootstenen, kookplaten en alle niet genoemde artikelen van roestvast staal reinigen u het beste met een sponsje of een vlieddoek met afwasmiddel of met de bekende speciale reinigers (v-s-rijger, metaal-pollish). Bij gootstenen van andere materialen zoals porselein, kunststof, acryl-keramiek en bij gootstenen van edelstaal milde afwas- of reinigingsmiddelen gebruiken. Neem bovendien de speciale reinigingsinstructies van de fabrikanten in acht!

Glaskeramische kookplaten:

Hardnekkig vuil, kalk- en watervlekken en glanzende slijfplekken van pannen verwijderd u met het door de fabrikant aanbevolen speciale reinigingsmiddel (bijv. Cerafix, Stahlfix). Aangekoekte en vastgebrande resten (suiker, zout of suikerhoudende voedselresten) verwijderd u, in nog hete toestand, met een glasschaber. Raadpleeg hiervoor ook de handleiding van de fabrikant van het apparaat!

Grepen:

Gebruik geen oplosmiddelhoudende en aluminium beschadigende substanties en geen schoonmaakzijn omdat deze tot vlekken kunnen leiden die niet meer te verwijderen zijn.

F Conseils d'entretien

Revêtements en plastique :

Les revêtements / fronts en plastique peuvent être entretenus au moyen d'un produit de nettoyage ménager courant. L'idéal est d'utiliser un chiffon doux, de l'eau tiède et un peu de produit pour la vaisselle. N'utilisez pas de produit de polissage ou d'éponges dures ! Éliminez les taches tenaces, telles que les projections de graisse et résidus de vernis ou de colle, au moyen d'un produit de nettoyage pour le plastique courant. Avant la première utilisation de ce produit, il est recommandé de tester celui-ci à un endroit dissimulé !

Fronts brillants :

Ne nettoyez jamais ces fronts à sec !
L'utilisation de produits de nettoyage abrasifs (chiffons en microfibre, éponges abrasives, etc.) peut entraîner la formation accrue de rayures et ne peuvent justifier aucune réclamation. L'idéal est donc d'utiliser un chiffon non-pelucheux ou une peau de chamomille humide.

Éviers encastrés et tables de cuisson :

Les éviers encastrés et tables de cuisson, ainsi que tous les éléments en acier inoxydable n'étant pas cités ici doivent être entretenus avec une éponge ou une peau de chamomille, imprégnées de produit vaisselle ou d'un produit spécifique (détergent inox, polish métal). Les éviers encastrés fabriqués dans d'autres matériaux, tels que de la porcelaine, du plastique, de la céramique acrylique, ainsi que les éviers en acier inoxydable doivent être nettoyés au moyen de produit vaisselle ou détergent doux. Respectez également les consignes d'entretien spécifiques du fabricant !

Plaques vitrocéramiques :

Éliminez les taches tenaces, les taches de calcaire et d'eau, ainsi que les traces brillantes laissées par les casseroles au moyen du produit spécial recommandé par le fabricant (par ex. Cerafix, Stahlfix). Éliminez les restes carbonisés (sucre, sel ou aliments sucrés) encore chauds au moyen un radloir. Respectez ici les instructions du fabricant de l'appareil !

Polignes :

N'utilisez pas de substances à base de solvant et décolorant l'aluminium ou produits à base de vinaigre ; ceux-ci peuvent causer des taches indélébiles.

