

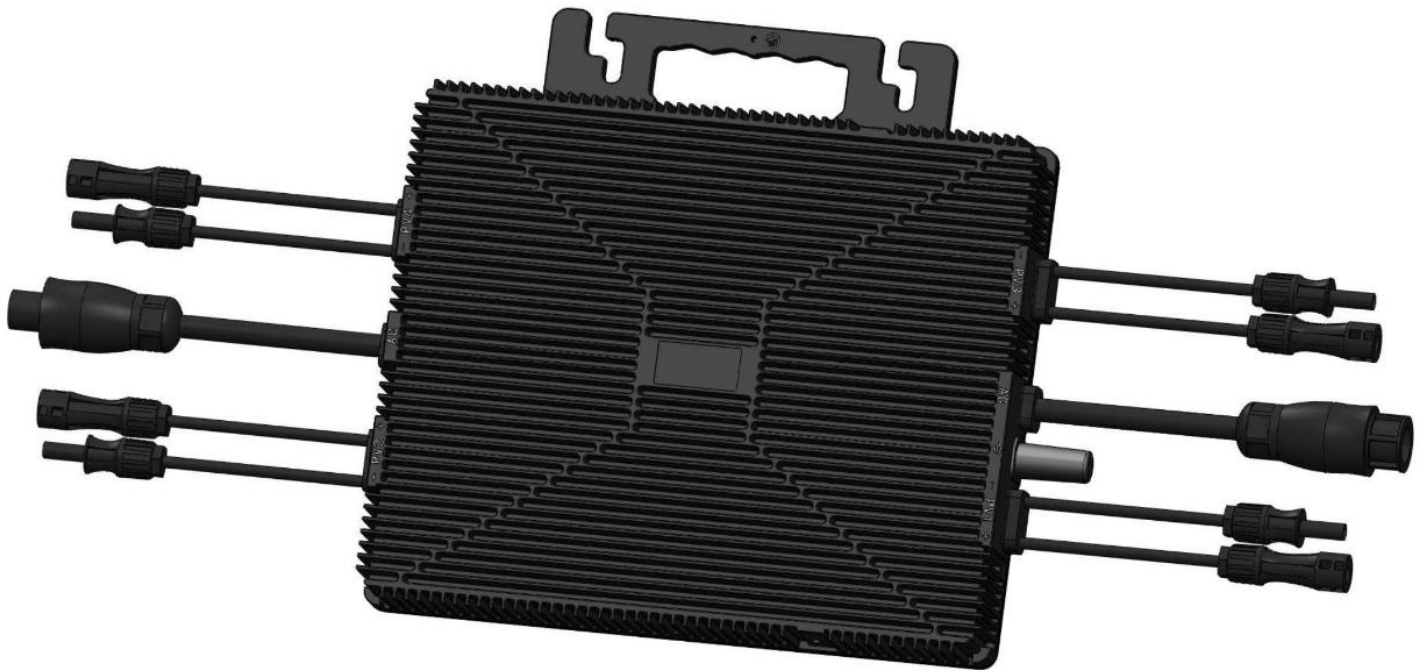

Astro-Energy Solar Microinverter TM-L2000M

User Manual



Zhejiang Astro-Energy Technology Co., LTD.

www.astro-e.com.cn

Address: Ningbo Zhejiang University Alumni Science and Innovation Park, Xiaying Street, Yinzhou District, Ningbo City, Zhejiang Province

Tel: 0574-8818-8211

Email: info@astro-e.com.cn

Contents

1. Safety Information	1
1.1 Safety Instructions	1
1.2 Radio Frequency Interference Statement	2
1.3 Meaning of Symbols	2
2. Overview of Astro-E Microinverter	3
2.1 Introduction to the Astro-E Microinverter System	3
3. Overview of the Astro-E Microinverter TM-L2000M	4
3.1 Introduction to the Astro-E Microinverter TM-L2000M	4
4. Installation Instructions for the Astro-E Microinverter System	5
4.1 Installation Tools Provided with the Astro-E Microinverter System	5
4.2 Parts and Tools Required by Customer	5
4.3 Installation Steps	6
4.3.1 Step 1: Verify that the grid voltage matches the voltage rating on the Microinverter’s label	6
4.3.2 Step 2: Connect the AC connector	6
4.3.3 Step 3: Install the Astro-E Microinverter on the bracket	6
4.3.4 Step 4: Ground the system	7
4.3.5 Step 5: Connect the Astro-E Microinverter	7
4.3.6 Step 6: Install the end cap on the AC cable’s female end at the Microinverter	7
4.3.7 Step 7: Connect the Astro-E Microinverter to the solar modules	7
4.3.8 Step 8: Connect the Microinverter to the grid	8
4.3.9 Step 9: Use the AC extension cord	8
4.4 Normal Operation of the Astro-E Microinverter Solar System	8
5. Monitoring Instructions for the Astro-E Microinverter Monitoring Platform	9
5.1. Monitoring Platform Download	9
5.2 Account Registration (Solarman Home)	10
5.2.1 Open the Solarman Home app and click ‘Register New Account’ to create an account	10
5.2.2 To create a power station, click ‘Add Now’ and fill in the basic information	10
5.2.3 To add a collector, click ‘+’ in the top right corner, then click ‘Add Collector’ and manually enter the SN number or scan the QR code.....	11
5.2.4 Configuring the network: Click ‘Proceed to Configure’ to set up the network and select 2.4G because 5G is not supported. (Ensure your phone’s Wi-Fi and Bluetooth are enabled.)	11

5.3 Account Registration (Solarman Pro)	12
5.3.1 To register, open the Solarman Pro app and click ‘Register’ to create an account.....	12
5.3.2 Creating a power station:	13
5.3.3 Adding a Collector: Click ‘+’, then ‘Add New Gateway/Collector’ and either scan the QR code or manually enter the SN number.....	13
5.3.4 Network Configuration	14
6. Troubleshooting and Maintenance Instructions	15
6.1 Status Indicators and Error Reporting	15
6.1.1 Operation indicator light	15
6.2 Troubleshooting Guide	15
6.3 Astro-E Technical Support	16
6.4 Troubleshooting Shutdown Issues with the Astro-E Microinverter	16
7. Microinverter Replacement	16
7.1 Replacing the Microinverter	16
8. Technical Specifications	16
8.1 TM-L2000M Technical Specifications	17
9. Appendix	19
9.1 Wiring Diagram for Reference	19
10. Attachments	20
10.1 Dimensional Drawing	20

1. Safety Information

The Astro-E Solar Microinverter TM-L2000M is designed and tested in strict accordance with national safety standards. However, for electronic devices, the installation, commissioning, operation and maintenance must adhere to relevant safety norms. Improper handling or usage could endanger:

- ① The life and physical safety of operators or third parties.
- ② The property of operators or third parties.

To ensure the safe installation and operation of the inverter and reduce the risk of electric shock, this manual employs specific safety symbols to indicate hazards and safety precautions. Detailed instructions for the operation will be further explained in the relevant sections.

Warning ⚠

All installation operations must be carried out solely by professional technicians. Qualified technicians must:

- ① Receive professional training.
- ② Thoroughly read and understand the safety information in this manual.
- ③ Be familiar with relevant safety standards for electrical systems.

1.1 Safety Instructions

Only qualified professionals are authorized to install and replace the Astro-E Microinverter.

Electrical installations of the Astro-E Microinverter must comply with local electrical codes.

Before installing and using the Astro-E Microinverter, read all instructions and warnings in this manual and on the inverter and solar array labels.

To avoid the risk of burns, do not touch the exterior of the Microinverter. The casing temperature can reach up to 80°C.

When disconnecting the Astro-E Microinverter from the solar modules, disconnect from the AC grid first.

Do not attempt to repair the Microinverter. In case of malfunction, contact Astro-E customer service for a return merchandise authorization and initiate the return process.

1.2 Radio Frequency Interference Statement

EMC Compliance: This device complies with relevant EMC requirements. The purpose of EMC regulations is to prevent harmful radio frequency interference when installing electronic products in residential areas. This device meets the requirements for Class B digital devices. If not installed or used according to the instructions, the device may emit radio frequency energy, potentially causing harmful interference to radio communications. However, that interference will not occur in a particular installation cannot be guaranteed. If this device causes harmful interference to radio or television reception, consult the dealer or ask someone skilled in radio technology for help. Any unauthorised changes may void the user's authority to operate the device.

1.3 Meaning of Symbols



Caution, risk of electric shock!



Caution, the surface is hot to touch!



Caution, high voltage danger!



The CE mark is affixed to the solar inverter to verify that the equipment complies with the regulations of the European Low Voltage and EMC Directives.



Refer to the operating instructions.



Symbol for the marking of electrical and electronics devices according to Directive 2002/96/EC. Indicates that the device, accessories and the packaging must not be disposed as unsorted municipal waste and must be collected separately at the end of the usage. Please follow Local Ordinances or Regulations for disposal or contact an authorized representative of the manufacturer for information concerning the decommissioning of equipment.

Qualified
Installation
Technicians

Individuals who are advised or supervised by electrical technicians, enabling them to perceive risks and avoid hazards that electricity might cause. In the context of this manual's safety information, 'qualified personnel' refers to individuals who are familiar with safety, electrical systems and EMC requirements and authorized to energize, ground and label equipment, systems and circuits following established safety procedures. The inverter and photovoltaic system must only be commissioned and operated by qualified personnel.

2. Overview of Astro-E Microinverter

2.1 Introduction to the Astro-E Microinverter System

The Astro-E Microinverter TM-L2000M solar energy system is designed for grid-tied applications, as shown in the system diagram below. It consists of:

Astro-E Microinverter

Wi-Fi Router

Monitoring and Analysis Cloud Platform

The Astro-E Microinverter enhances system power generation, improves safety, increases system reliability and simplifies the design, installation, maintenance and management of solar energy systems (Software Version: TM2000BR1.0).

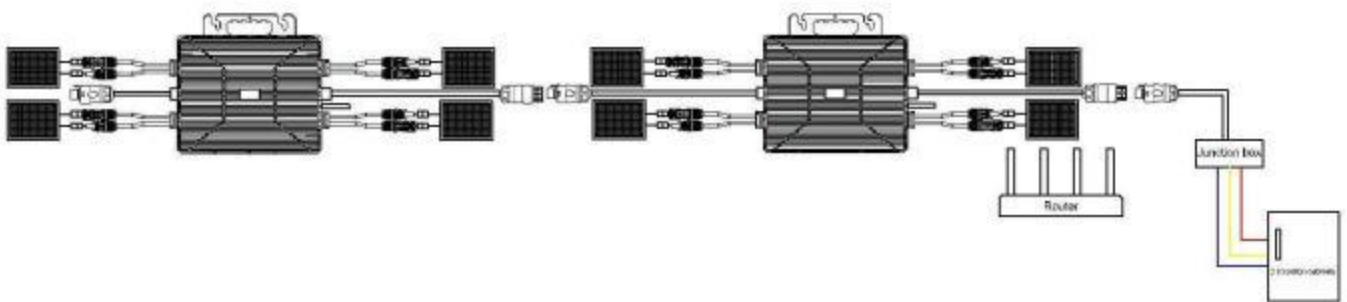

3. Overview of the Astro-E Microinverter TM-L2000M

3.1 Introduction to the Astro-E Microinverter TM-L2000M

The Astro-E Microinverter TM-L2000M boasts an output power of up to 2000 W, catering to today's mainstream solar modules. The inverter is an isolated inverter with an internal isolation transformer (reinforced insulation). Innovation and rigorous design have maximized energy production. The product utilizes full silicone encapsulation to reduce stress on electronic components, enhance heat dissipation, improve waterproofing and ensure reliability through stringent testing methods. System monitoring is available around the clock via an app or web portal, facilitating convenient operation and maintenance.

Key Features of the Astro-E Microinverter TM-L2000M:

- Accommodates 4 solar panels per unit ($V_{oc} < 60$ Vdc)
- Output power of 2000 W
- IP67-rated for high-level protection
- Wi-Fi communication capabilities
- Built-in safety protection relay
- Compatible with crystalline silicon modules

4. Installation Instructions for the Astro-E Microinverter System

The installation of the Astro-E Microinverter solar system is user-friendly. The Microinverter can be easily mounted on the module rack. Installation must comply with local regulations and technical standards.

Special Note: We recommend installing a residual-current device only as required by local electrical codes.

Warning 

- ① Adhere to local electrical codes for installation.
- ② Only qualified professionals should perform the installation and replacement of the Microinverter.
- ③ Ensure reliable grounding of the solar modules and racks used with the Microinverter.
- ④ Before installing and using the Microinverter, read all instructions and warnings in this manual, as well as the labels on the Microinverter and solar modules.

4.1 Installation Tools Provided with the Astro-E Microinverter System

- AC connector end caps
- Removal tool
- Antenna rod

4.2 Parts and Tools Required by Customer

In addition to the solar modules and their related hardware, customers need to prepare:

AC junction box

Hardware suitable for mounting brackets

Socket and wrench for mounting hardware

Multi-meter, safety goggles and other relevant auxiliary tools

4.3 Installation Steps

4.3.1 Step 1: Verify that the grid voltage matches the voltage rating on the Microinverter's label.

4.3.2 Step 2: Connect the AC connector.

- Position the Microinverter and AC cable at their appropriate locations.
- Connect the AC male port of the Microinverter to the combiner box or integrate it into the grid.
- Wiring method: Live (L) - red; Neutral (N) - black; Protective Earth (PE) - yellow/green.

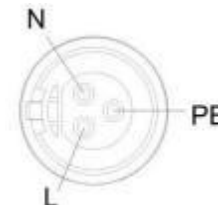

Warning ⚠

Wiring colours may vary by region. Check all the electrical wires before connecting the Microinverter to ensure they match. Incorrect wiring can damage the Microinverter and is not covered under the warranty. You are advised to use the TC-ER 12AWG AC cable to connect the micro inverter, The diameter of an AC cable must not be smaller than 14AWG.

Warning ⚠

Do not carry the inverter by the AC cables during transportation.

4.3.3 Step 3: Install the Astro-E Microinverter on the bracket.

- Mark the position on the bracket where the Microinverter will be installed, considering the distance from the solar module's junction box or any other obstructions.
- Use the parts and tools recommended by the bracket supplier to secure each Microinverter in its designated position. Ensure the grounding clip of the inverter is facing towards the bracket.



Warning ⚠

Do not install the Microinverter in places directly exposed to sunlight, rain or snow, including the gaps between panels. A fully covered installation point is preferable. Ensure ample ventilation space around the Microinverter for cooling. The bracket for the inverter must be reliably grounded.

4.3.4 Step 4: Ground the system.

Before connecting the DC input and AC output, the grounding hole provided by the Microinverter must be connected to an external ground..The PV modules used to connected to this inverter shall be Class A rating certified according to IEC 61730.

4.3.5 Step 5: Connect the Astro-E Microinverter.

Insert the AC male connector of the Microinverter into the AC female connector until a clear ‘click’ sound is heard.

Note: The maximum number of microinverter branches that can be connected cannot exceed 3

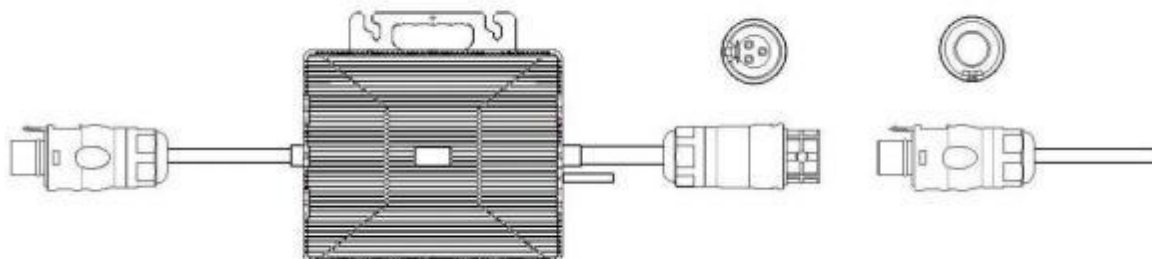

4.3.6 Step 6: Install the end cap on the AC cable’s female end at the Microinverter.

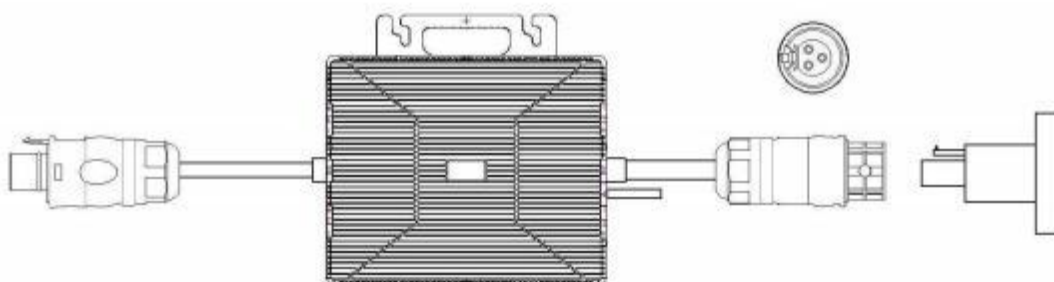

4.3.7 Step 7: Connect the Astro-E Microinverter to the solar modules.

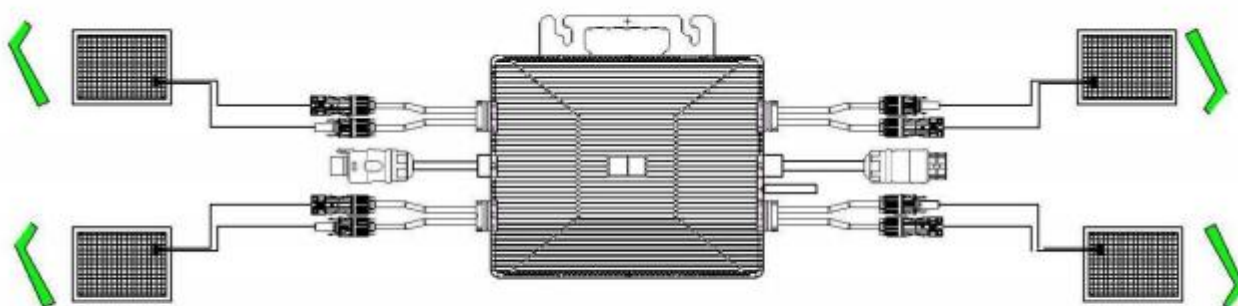

Warning ⚠

The connection cable between the PV module and Astro-E Microinverter must be less than 3 meters.

The PV modules should not be grounded

4.3.8 Step 8: Connect the Microinverter to the grid.

Caution

Install an AC circuit breaker (air switch) at the grid connection point in accordance with the access capacity or regulatory requirements.

Do not install a residual current device (RCD) for the photovoltaic power system to avoid false triggering of the protection mechanism.

4.3.9 Step 9: Use the AC extension cord.

When the use of an AC extension cord is necessary, users may connect it to the Microinverter's AC port. Alternatively, the Astro-E Solar AC connector (available as an optional purchase) can be used.

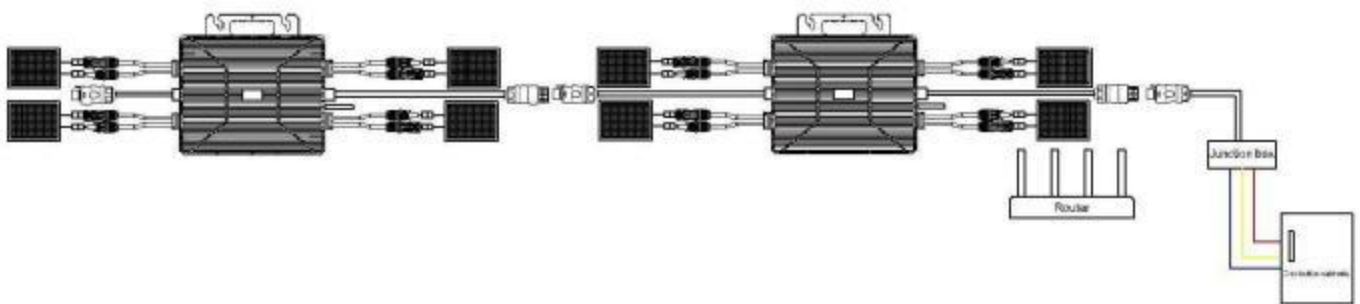

4.4 Normal Operation of the Astro-E Microinverter Solar System

To ensure the normal operation of the Astro-E Microinverter solar system:

1. Close the AC circuit breaker for each Microinverter branch.
2. Close the main grid circuit breaker, and the system will start generating electricity after approximately one minute.
3. The Microinverter's LED behaviour can serve as an indicator of the Microinverter's status.

5. Monitoring Instructions for the Astro-E Microinverter Monitoring Platform

5.1. Monitoring Platform Download

For residential users of photovoltaic power stations, using the ‘Solarman Home’ app is recommended. Scan the QR code below to download the app or search for ‘Solarman Home’ in the Google Play Store (Android) or App Store (iPhone). You can also visit the web version (<https://home.solarmanpv.com>) to view data.



Solarman Home

For professionals in the photovoltaic industry, such as dealers, equipment vendors or maintenance service providers, it is recommended to use the ‘Solarman Pro’ app. Scan the QR code below to download the app or search for ‘Solarman Pro’ in the Google Play Store (Android) or App Store (iPhone). You can also log in to the web version (<https://pro.solarmanpv.com>) to view data.



Solarman Pro

5.2 Account Registration (Solarman Home)

5.2.1 Open the Solarman Home app and click ‘Register New Account’ to create an account.

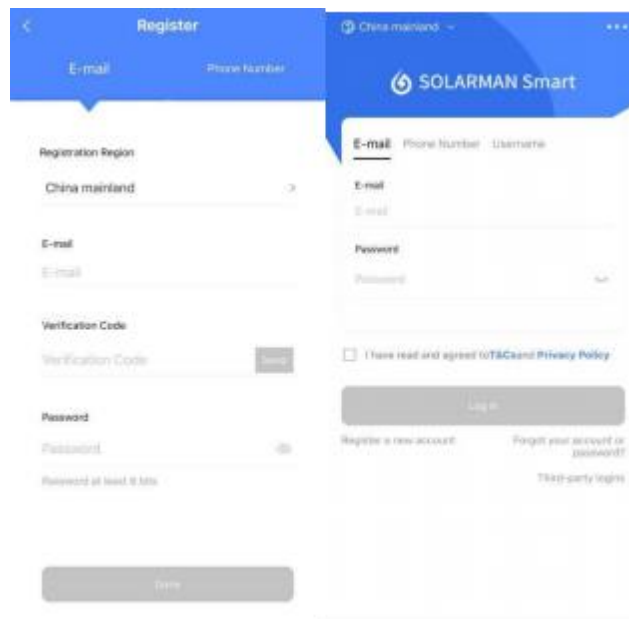

5.2.2 To create a power station, click ‘Add Now’ and fill in the basic information.

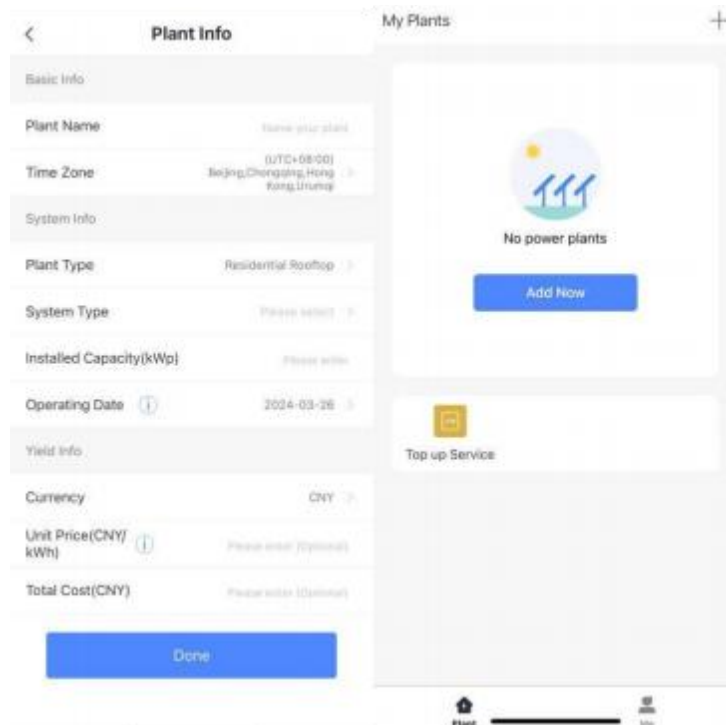

5.2.3 To add a collector, click ‘+’ in the top right corner, then click ‘Add Collector’ and manually enter the SN number or scan the QR code

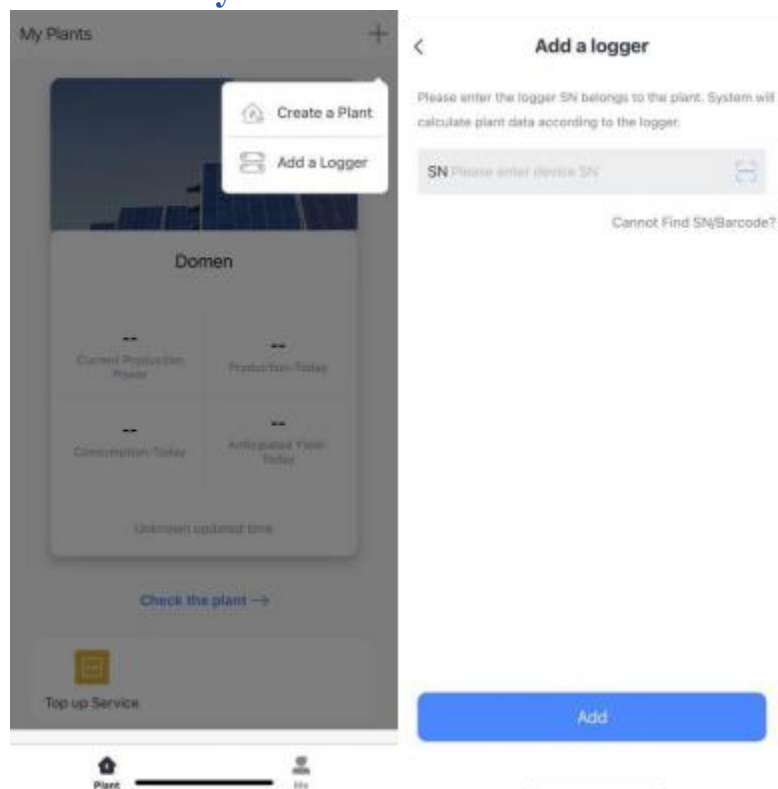

5.2.4 Configuring the network: Click ‘Proceed to Configure’ to set up the network and select 2.4G because 5G is not supported. (Ensure your phone’s Wi-Fi and Bluetooth are enabled.)

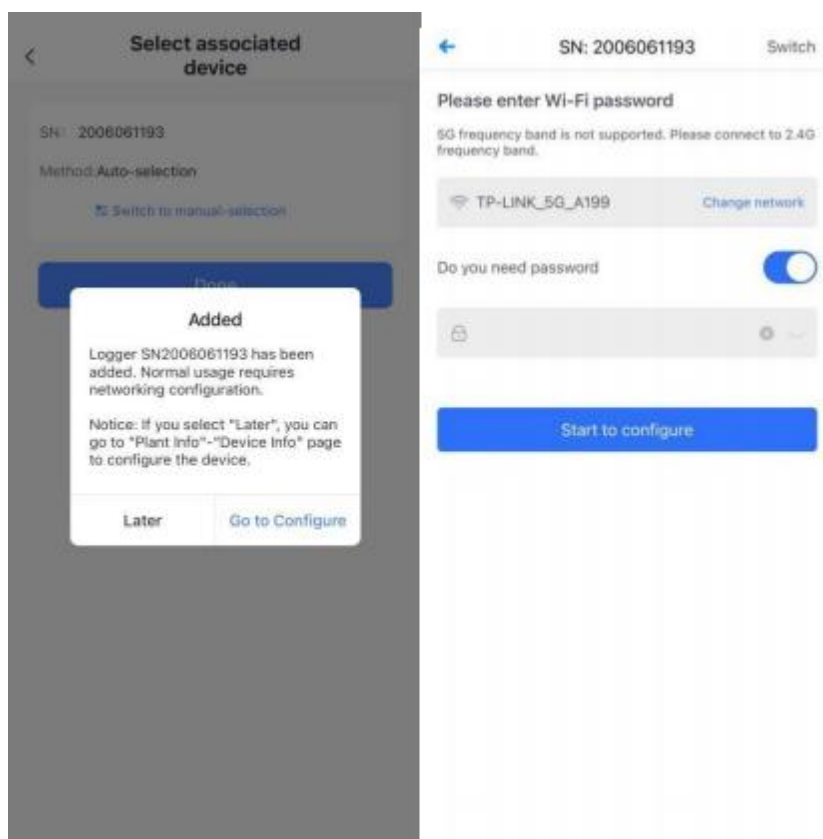

Wait a few minutes, then click 'Finish' to view the power station data.

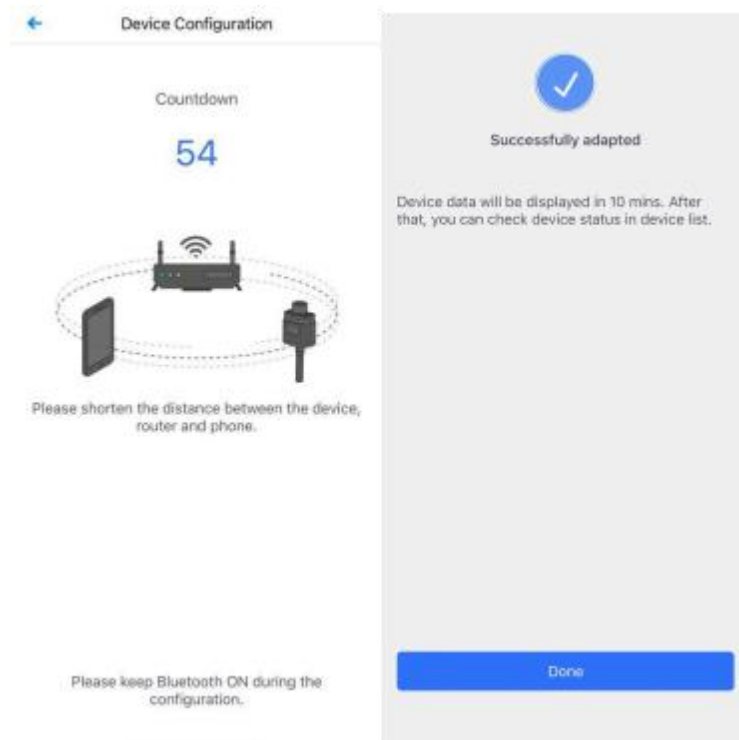

5.3 Account Registration (Solarman Pro)

5.3.1 To register, open the Solarman Pro app and click 'Register' to create an account.

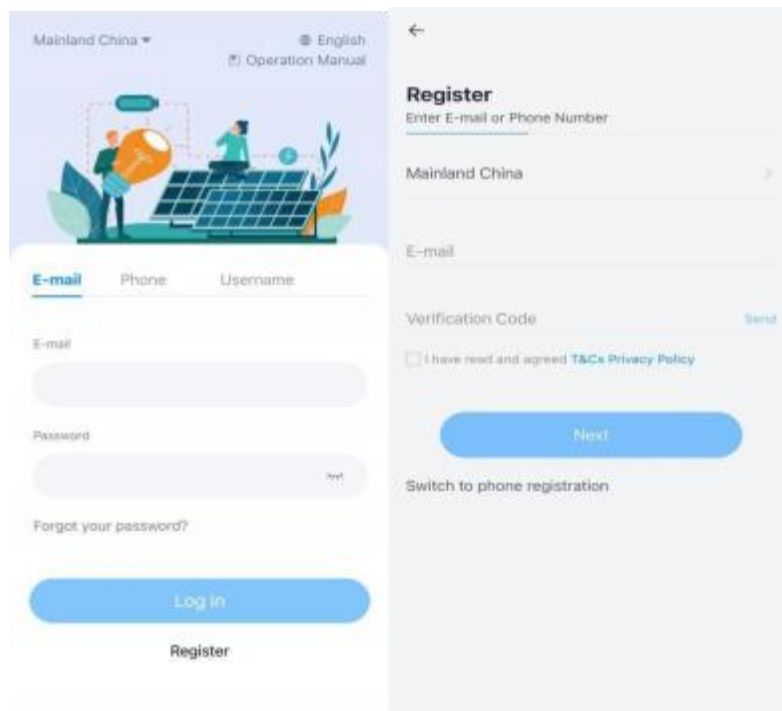

5.3.2 Creating a power station:

Click the ‘+’ icon in the top right corner, then click ‘Power Station’ and fill in the basic information.

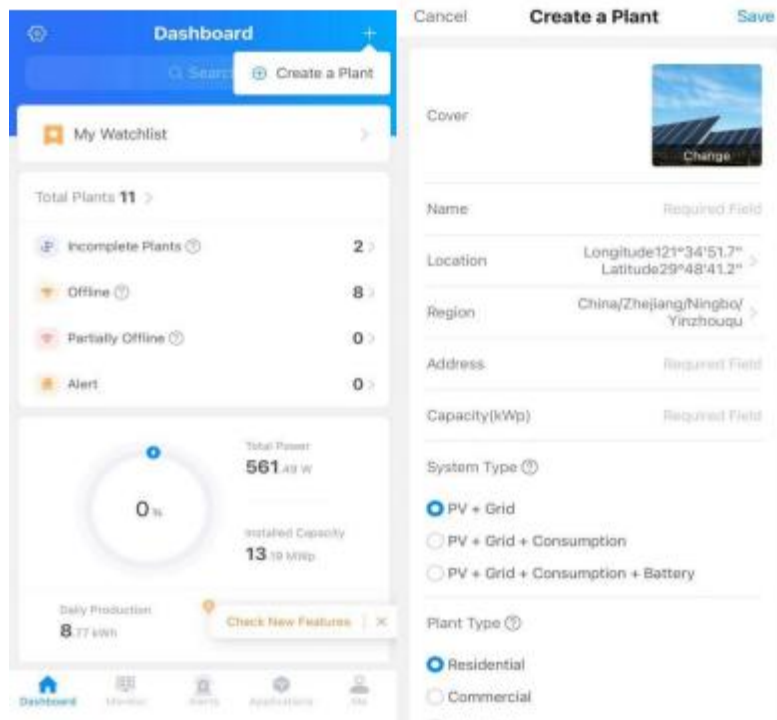

5.3.3 Adding a Collector: Click ‘+’, then ‘Add New Gateway/Collector’ and either scan the QR code or manually enter the SN number.

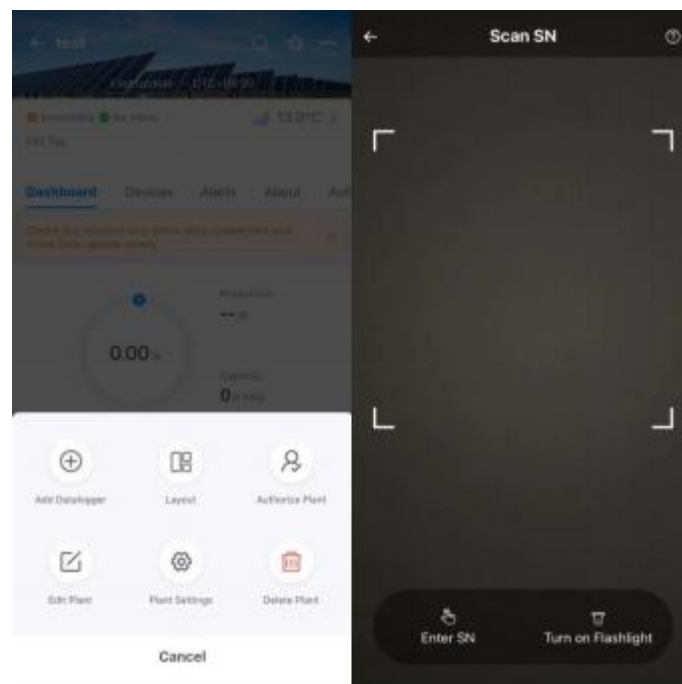

5.3.4 Network Configuration

Click ‘Application’ > ‘Wi-Fi Configuration’, then scan the QR code or manually enter the SN number. Choose 2.4 G because 5 G is not supported

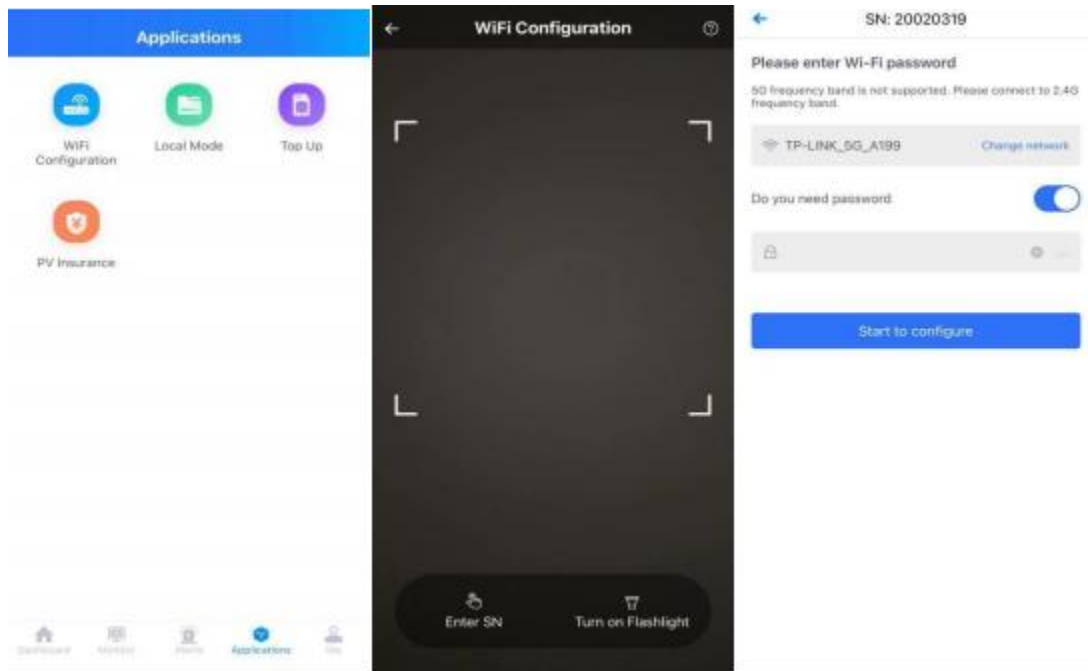

Wait a few minutes, then click ‘Finish’ to view the power station data.

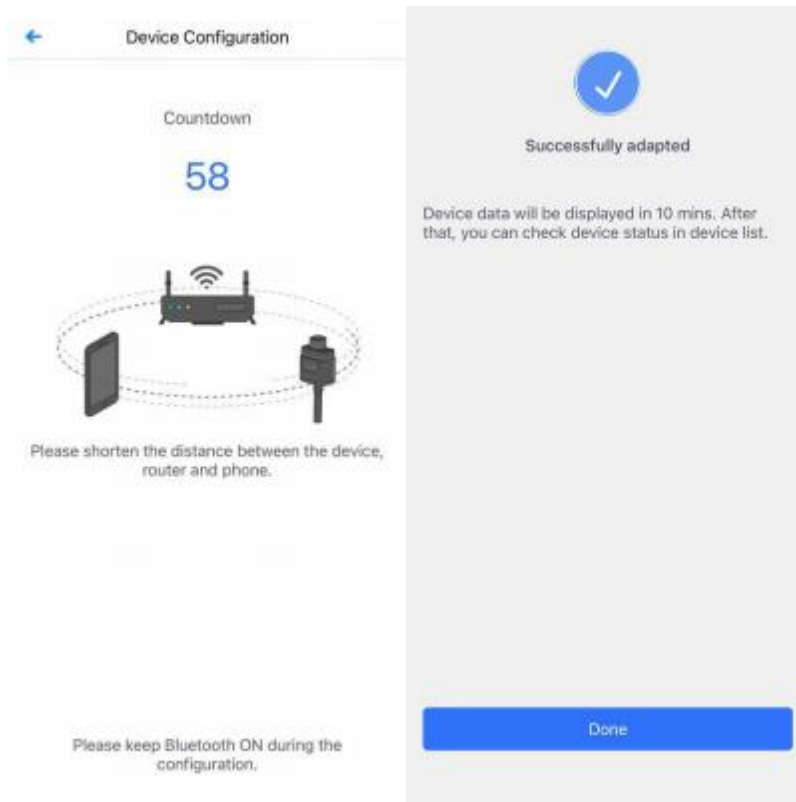

6. Troubleshooting and Maintenance Instructions

Only qualified professionals should perform the following troubleshooting actions when the Astro-E Microinverter solar system is not functioning correctly.

6.1 Status Indicators and Error Reporting

Observing the indicator lights can provide a good understanding of the Microinverter's status.

6.1.1 Operation indicator light

If the LED is off, check the DC side wiring or contact your local dealer.

If the red light is continuously on, check whether DC inputs are connected correctly.

6.2 Troubleshooting Guide

Before going on-site for troubleshooting, installers can remotely check all information via their installer account, either on the web or using the mobile app. Accessing module data (DC, AC, voltage and current) can offer an initial understanding of potential issues. Professional installers can also refer to our troubleshooting guide for a comprehensive approach to diagnosing and fixing issues with photovoltaic installations powered by the Astro-E Microinverter.

6.3 Astro-E Technical Support

The Astro-E technical support team is available to assist professional installers in becoming familiar with our products and provide troubleshooting support for installations when necessary.

6.4 Troubleshooting Shutdown Issues with the Astro-E Microinverter

The Astro-E Microinverter requires no specific routine maintenance.

Warning ⚠

Do not attempt to repair the Astro-E Microinverter yourself. If troubleshooting efforts fail, return the unit to the manufacturer for replacement.

Warning ⚠

Only qualified professionals are allowed to perform troubleshooting procedures on the Astro-E Microinverter.

Warning ⚠

1. Do not disconnect the DC side of the inverter while it is still operational. Ensure there is no current flow before disconnecting the DC side.
2. When disconnecting the Astro-E Microinverter from the solar modules, disconnect from the AC grid first, and ensure that the grounding hole provided by the Microinverter remains grounded at all times.
3. The Astro-E Microinverter is powered via the DC side of the solar modules.

7. Microinverter Replacement

7.1 Replacing the Microinverter

Follow the steps below to replace a faulty Astro-E Microinverter:

A. Disconnect the Astro-E Microinverter and the solar modules in the following order:

1. Turn off the branch AC circuit breaker.
2. Disconnect the AC connector of the Microinverter.
3. Disconnect the DC connector between the solar modules and the Microinverter.
4. Remove the Microinverter from the photovoltaic rack.

B. Install the replacement Microinverter onto the rack. When connecting the DC wires to the new Microinverter, observe the indicator light's behaviour.

C. Connect the AC connector of the replaced Microinverter.

D. Close the branch circuit breaker and verify the operational status of the replacement Microinverter.

8. Technical Specifications

Warning ⚠

- ① Ensure that the output current and voltage of the solar modules match those of the Microinverter.
- ② The DC operating voltage range of the solar modules must fall within the input voltage range of the Astro-E Microinverter.
- ③ The maximum open-circuit voltage of the solar modules must not exceed the maximum input voltage of the Astro-E Microinverter.

8.1 TM-L2000M Technical Specifications

Model	TM-L2000M
Input Data (DC)	
Recommended PV Module Power	280W-650W
Start-up Voltage	28V
MPPT Voltage Range	28-55V
Full load voltage range	40-55V
Max. Input Voltage	60V
Max. Input Current	14.5A*4
Max. DC Short Circuit Current	19A*4
Number of MPPTs	4
Output Data (AC)	
Rated output power	2000W
Apparent power	2000VA
Maximum output power	2000W
Nominal Output Voltage	~L/N/PE,220V
Extended Output Voltage Range	176V-242V
Maximum Current	12A
Nominal Output Current	9.1A
Nominal Frequency/Range	60Hz/55 - 65
Power Factor	>0.99 (Default)
Total Harmonic Distortion (THD)	<3%
Max. Units Per Branch	3
Efficiency	
Peak Efficiency	96%
CEC Efficiency	95.5%
Static MPPT Efficiency	99.5%
Night Time Power Consumption	<50mW

Mechanical Data	
Ambient Temperature Range	-25°C to +65°C
Dimensions(WxHxD)	312*301*43mm
Weight	7kg
Enclosure Rating	IP 67
Cooling	Natural Convection - No Fans
Type of Isolation	High Frequency Transformers
Monitoring & Communication	
Communication	WiFi
Energy Management	Solarman Online Platform
Certifications & Warranty	
Overvoltage category	II(PV), III(Mains)
Inverter topology	Isolated
Certifications	IEC/EN 62109-1 , IEC/EN 62109-2; IEC/EN 61000-6; Ordinance No.140
Warranty	10 Years Standard

Note: This manual is subject to change without notice. For any inquiries, contact Astro-E customer service.

9. Appendix

9.1 Wiring Diagram for Reference

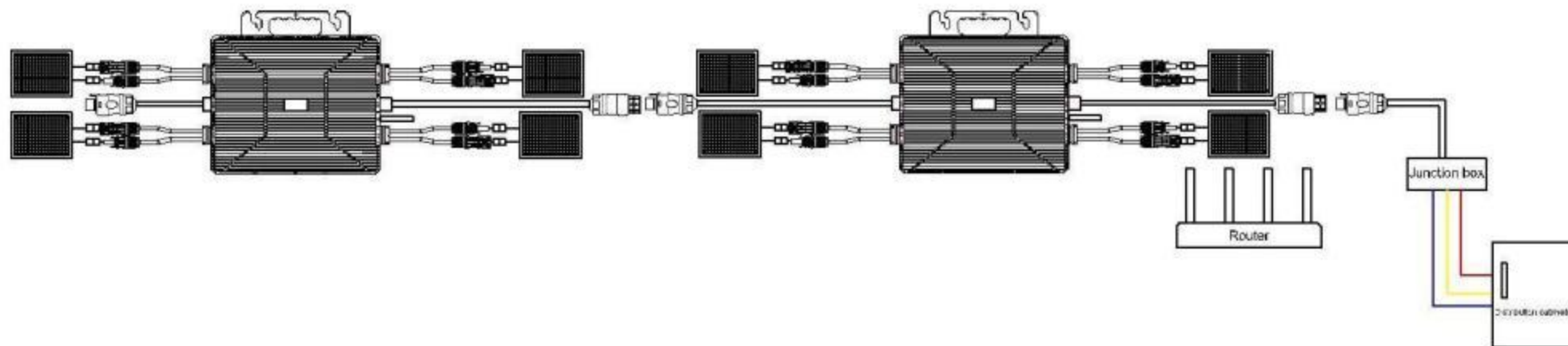

10. Attachments

10.1 Dimensional Drawing

