

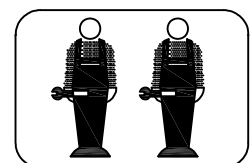
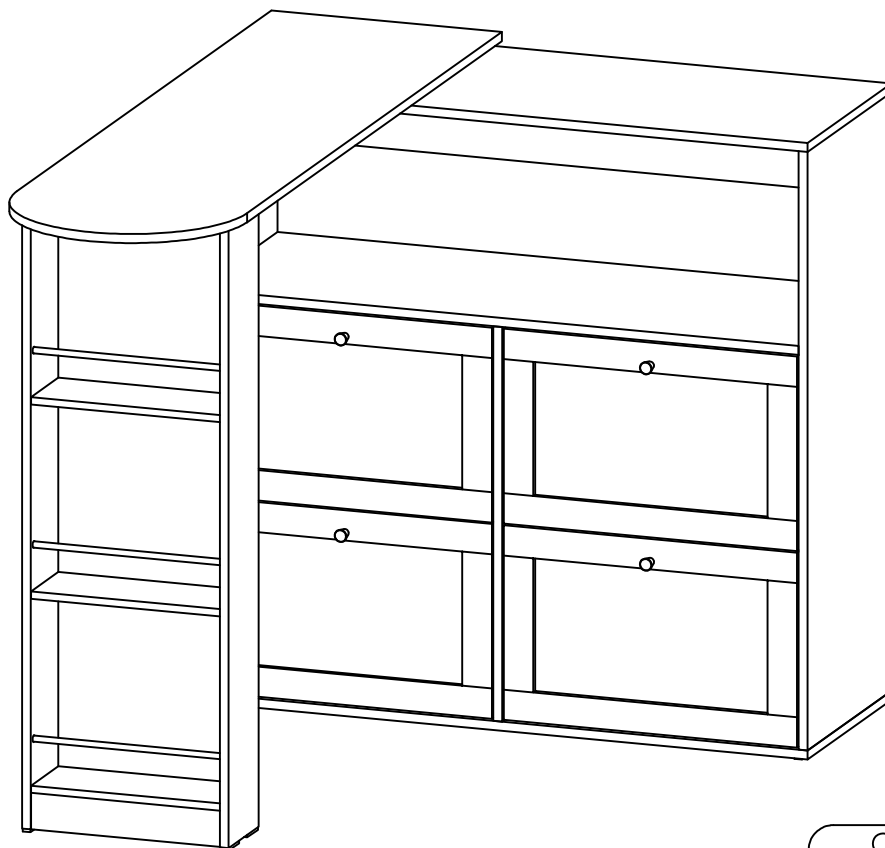

Installationsanleitung Installation Instruction Instruction d'installation N620P193303/N620P193306

DE: Unser Produkt wird Ihnen in 2 Paketen geliefert. Die Lieferzeiten dieser 2 Pakete können abweichen, bitte haben Sie etwas Geduld und vielen Dank für Ihr Verständnis.

UK: Our product will be delivered to you in 2 packages. The delivery times of these 2 packages may differ, please be patient and thank you for your understanding.

FR: Notre produit vous sera livré en 2 colis. Les délais de livraison de ces 2 colis peuvent différer, soyez patient et merci pour votre compréhension.



 Ø15×12mm	 Ø15×10mm
Ⓑ×21pcs	Ⓒ×42pcs

Bitte beachten Sie, dass die Formen der Schrauben B und C ähnlich sind. Bitte installieren Sie entsprechend der Anleitung und unterscheiden Sie sie!

Please note that the shapes of screws B and C are similar. Please install according to the instructions and distinguish them!

Notez que les vis B et C ont des formes similaires. Veuillez les installer en suivant les instructions pour les séparer!

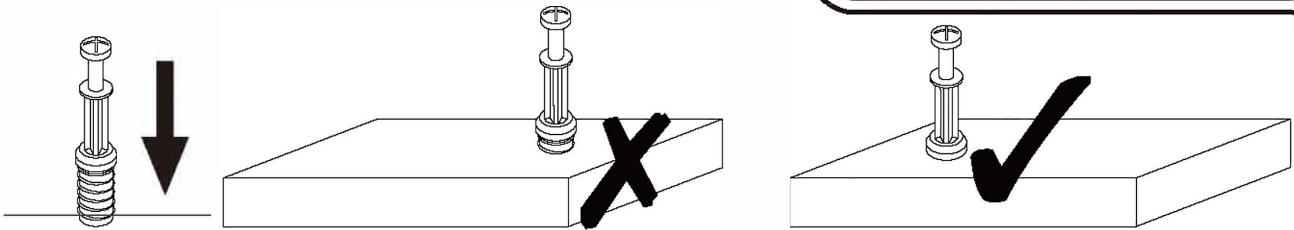

EN_QUICKFIT: Tighten quickfit until shoulder is flush with panel. Do not overtighten or undertighten.

FR_RACCORD RAPIDE: Faites serrer le raccord rapide jusqu'à ce que l'épaulement soit parfaitement encastré dans le panneau. Il ne faut ni trop serrer ni insuffisamment serrer.

ES_QUICKFIT: Apriete quickfit hasta que el hombro se descargue con el panel. NO lo sobreapriete ni lo apriete poco.

DE_QUICKFIT: Ziehen Sie den Quickfit fest, bis die Schulter mit der Platte bündig ist. Bitte nicht zu fest oder zu schwach anziehen.

IT_MONTAGGIO RAPIDO: Stringere il montaggio rapido fino a quando la spalla è a filo con il pannello, non stringere troppo o troppo poco.

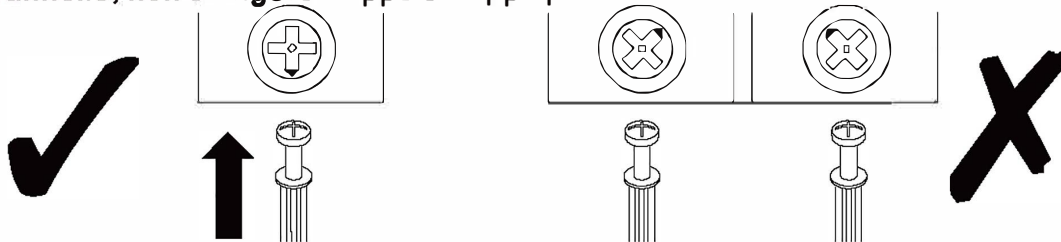

EN_CAM LOCK: When fitting cam lock, ensure starting position is correct before you insert connecting quickfit.

FR_SERRURE BATTEUSE: Avant d'insérer la serrure batteuse, veillez à la bonne orientation avant d'insérer le raccord rapide.

ES_CIERRE DE LA CÁMARA: Cuando instale el cierre de la cámara, asegúrese de que la posición de inicio es correcta antes de que inserte el quickfit conector.

DE_CAM-LOCK: Achten Sie bei der Montage des Cam-Locks auf die richtige Ausgangsposition, bevor Sie den Quickfit einsetzen.

IT_BLOCCAGGIO A CAMMA: Quando si monta il bloccaggio a camma, assicurarsi che la posizione iniziale sia corretta prima di inserire il montaggio rapido di collegamento.

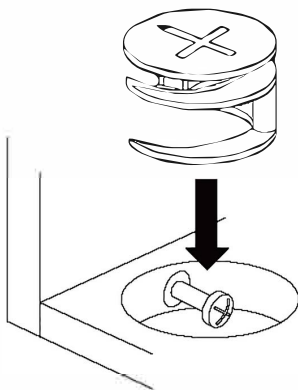

EN_Quickfit head should be in the centre of the cam lock when the two panels are joined.

Cam lock should be inserted before quickfit.

FR_Lorsque les deux panneaux sont assemblés, la tête du raccord rapide doit reposer au centre de la serrure batteuse.

Il faut insérer la serrure batteuse avant le raccord rapide.

ES_El cabezal del quickfit debe estar en el centro del cierre de la cámara cuando se unan los dos paneles.

Se debe insertar el cierre de la cámara antes que el quickfit.

DE_Der Quickfit-Kopf sollte sich in der Mitte des Cam-Locks befinden, wenn die beiden Platten zusammengefügt sind.

Der Cam-Lock sollte vor dem Quickfit eingesetzt werden.

IT_La testa del montaggio rapido deve trovarsi al centro del bloccaggio a camma quando i due pannelli sono uniti.

Il Bloccaggio a Camma deve essere inserito prima del montaggio rapido.

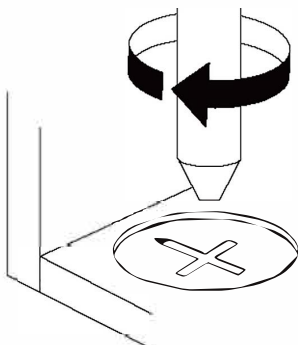

EN_Turn cam lock clockwise to tighten.

FR_Faites tourner la serrure batteuse dans le sens des aiguilles d'une montre pour la resserrer.

ES_Gire el cierre de la cámara en sentido horario para apretarlo.

DE_Drehen Sie den Cam-Lock im Uhrzeigersinn, um ihn festzuziehen.

IT_Ruotare il bloccaggio a camma in senso orario per stringere.





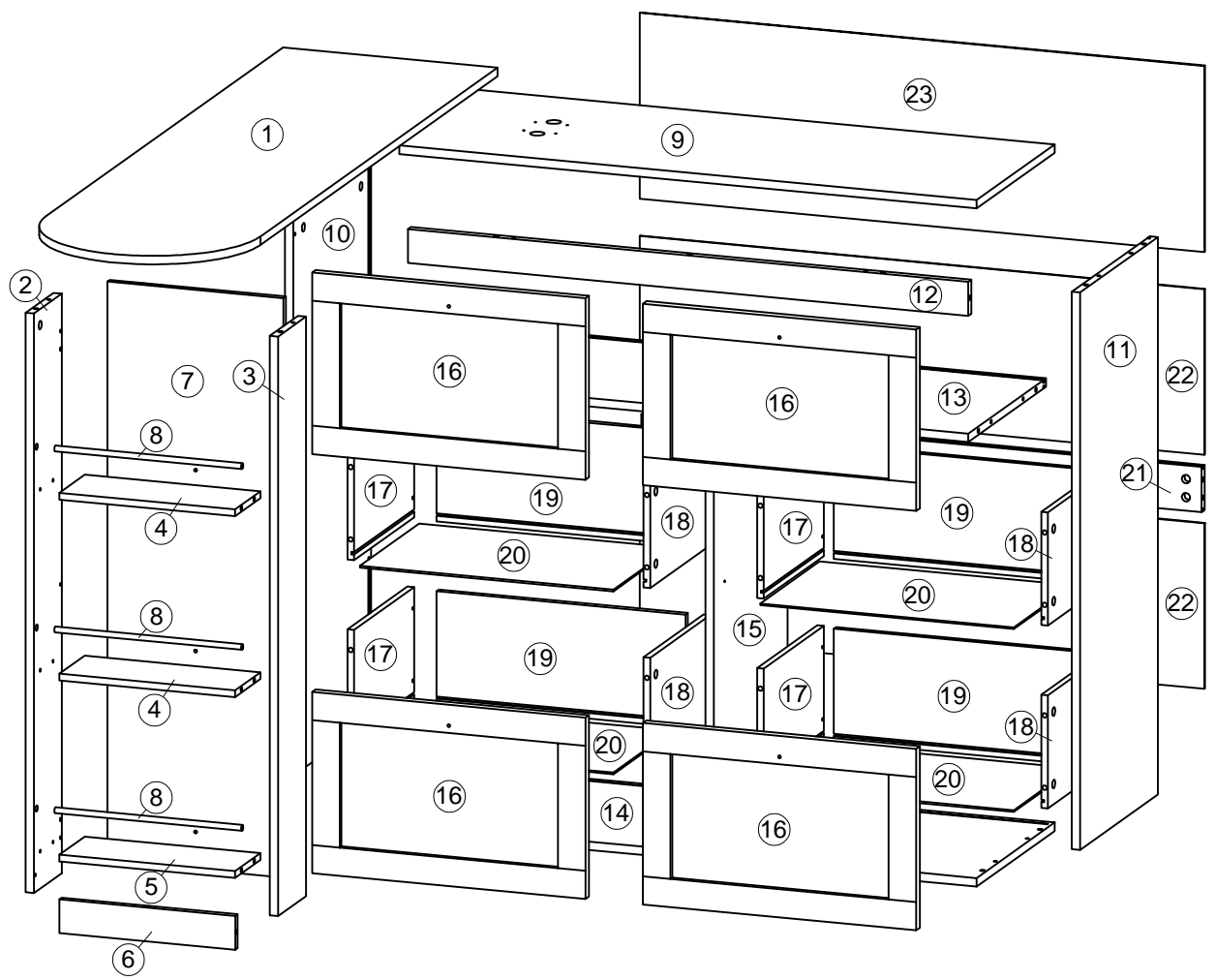

Vor dem Einbau die Schrauben in die Löcher stecken und festziehen, aber nicht bis 100%, 70% bis 80% anziehen reicht aus. Schließlich, nachdem alle Schrauben installiert sind, ziehen Sie alle Schrauben auf 100%. Wenn Sie auf diese Probleme stoßen, z.B. wenn die Löcher nicht ausgerichtet werden können oder einige Teile nicht installiert werden können, überprüfen Sie bitte, ob die Schrauben korrekt verwendet werden und passen Sie die Dichtigkeit der Schrauben an.

Before installation, insert the screws into the holes and tighten them, but do not tighten them to 100%, 70% to 80% is sufficient. Finally, after all screws are installed, tighten all screws to 100%. If you encounter these issues, such as if the holes cannot be aligned or some parts cannot be installed, please check if the screws are used correctly and adjust the tightness of the screws.

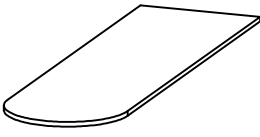

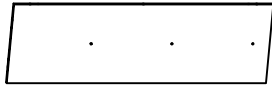

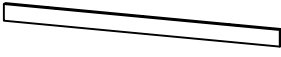
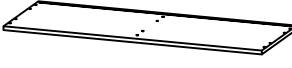
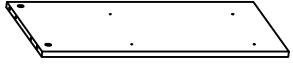
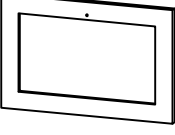

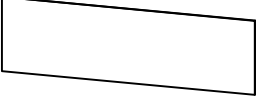
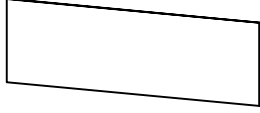

Insérer la vis dans le trou avant la fin de l'assemblage, serrer la vis, mais ne pas serrer à 100%, 70% ~ 80% est bien. Enfin, une fois que toutes les vis sont bien serrées, toutes les vis sont serrées à 100%. Si vous rencontrez ces problèmes, par exemple si les trous ne sont pas alignés ou si certaines pièces ne peuvent pas être montées, vérifiez que les vis sont utilisées correctement et ajustez leur serrage.

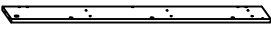
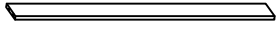

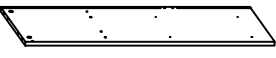
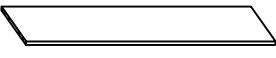
N620P193303B

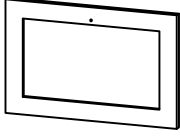



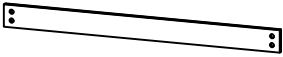





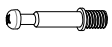

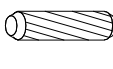

			
①×1pc	④×2pcs	⑤×1pc	⑦×1pc
			
⑨×1pc	⑫×1pc	⑭×1pc	⑮×1pc
			
⑯×2pcs	⑳×4pcs	㉒×2pcs	㉓×1pc

N620P193306B

			
②×1pc	③×1pc	⑥×1pc	⑧×3pcs
			
⑩×1pc	⑪×1pc	⑬×1pc	⑯×2pcs
			
⑰×4pcs	⑱×4pcs	⑲×4pcs	㉑×1pc

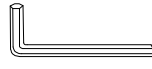
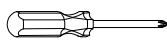
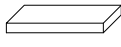

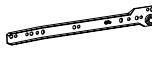
Hardware List

Hardwareliste

 Ø6×35mm A ×63pcs	 Ø15×12mm B ×21pcs	 Ø15×10mm C ×42pcs	 Ø6×30mm D ×26pcs	 E ×4pcs
 M4×22mm F ×4pcs	 H ×24pcs	 4×35mm L ×16pcs	 3.5×14mm M ×58pcs	 N ×1pc
 Ø7×40mm O ×6pcs	 M4 Q ×1pc	 S ×1pc	 13×50×5mm T ×10pcs	 14×14×9mm U ×18pcs
 L300mm CL ×4pcs	 L300mm CR ×4pcs	 L300mm DL ×4pcs	 L300mm DR ×4pcs	

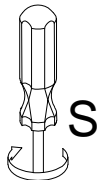
Step 1
Schritt 1

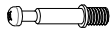

 Ø6×35mm	 3.5×14mm	
Ⓐ ×20pcs	Ⓜ ×4pcs	Ⓝ ×1pc

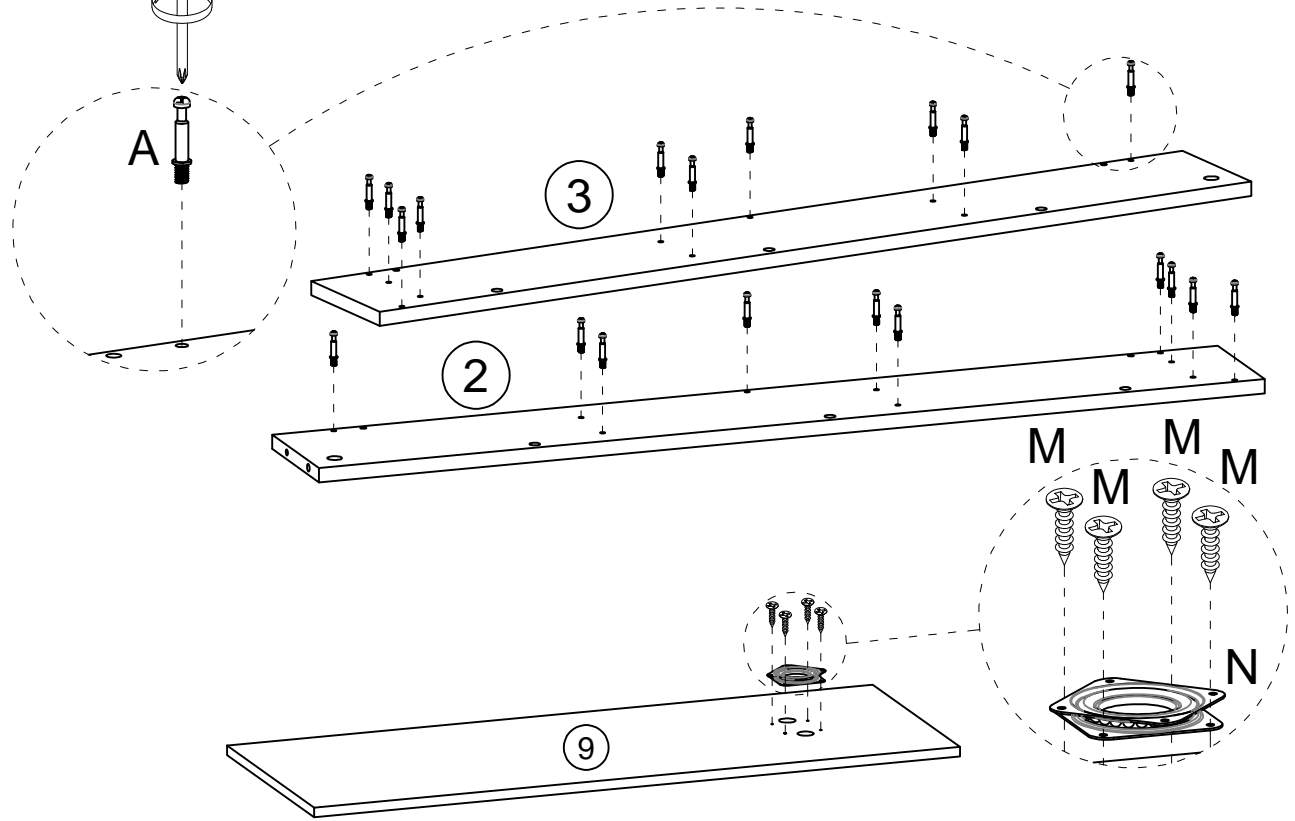

Step 2
Schritt 2

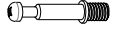
 Ø6×35mm
Ⓐ ×43pcs

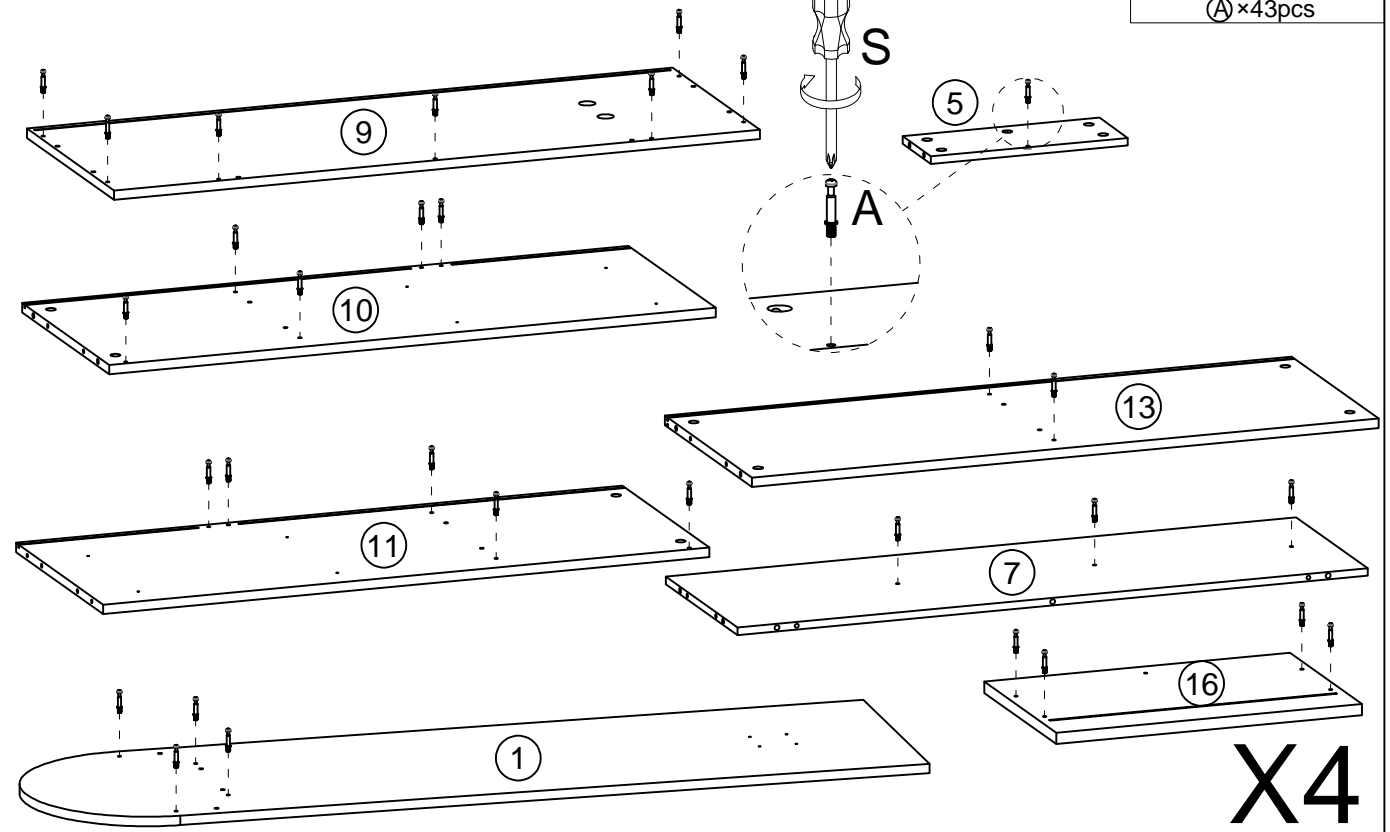
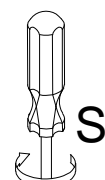

X4

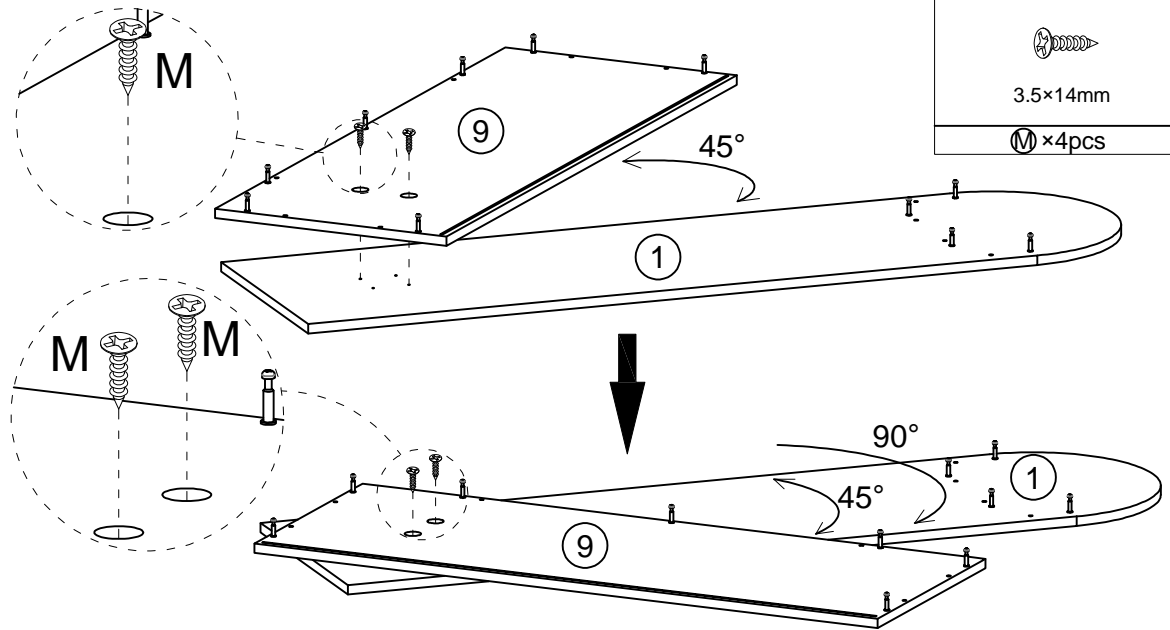

Step 3 Schritt 3



Machen Sie Brett 9 und Brett 1 in einem 45-Grad-Winkel, sperren Sie die diagonalen Schrauben des kleinen Plattentellers durch die zwei kreisförmigen Löcher an Bord 9, drehen Sie dann Brett 9 90 Grad und sperren Sie die anderen beiden diagonalen Schrauben des kleinen Plattentellers
 Make board 9 and board 1 at a 45 degree angle, lock the diagonal screws of the small turntable through the two circular holes on board 9, then rotate board 9 90 degrees and lock the other two diagonal screws of the small turntable

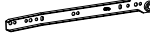

Laissez les plaques 9 et 1 à un angle de 45 degrés, Verrouillez les vis diagonales du petit Carrousel à travers les deux trous ronds de la plaque 9, puis tournez la plaque 9 à 90 degrés pour verrouiller les deux autres vis diagonales du petit Carrousel.

Step 4 Schritt 4

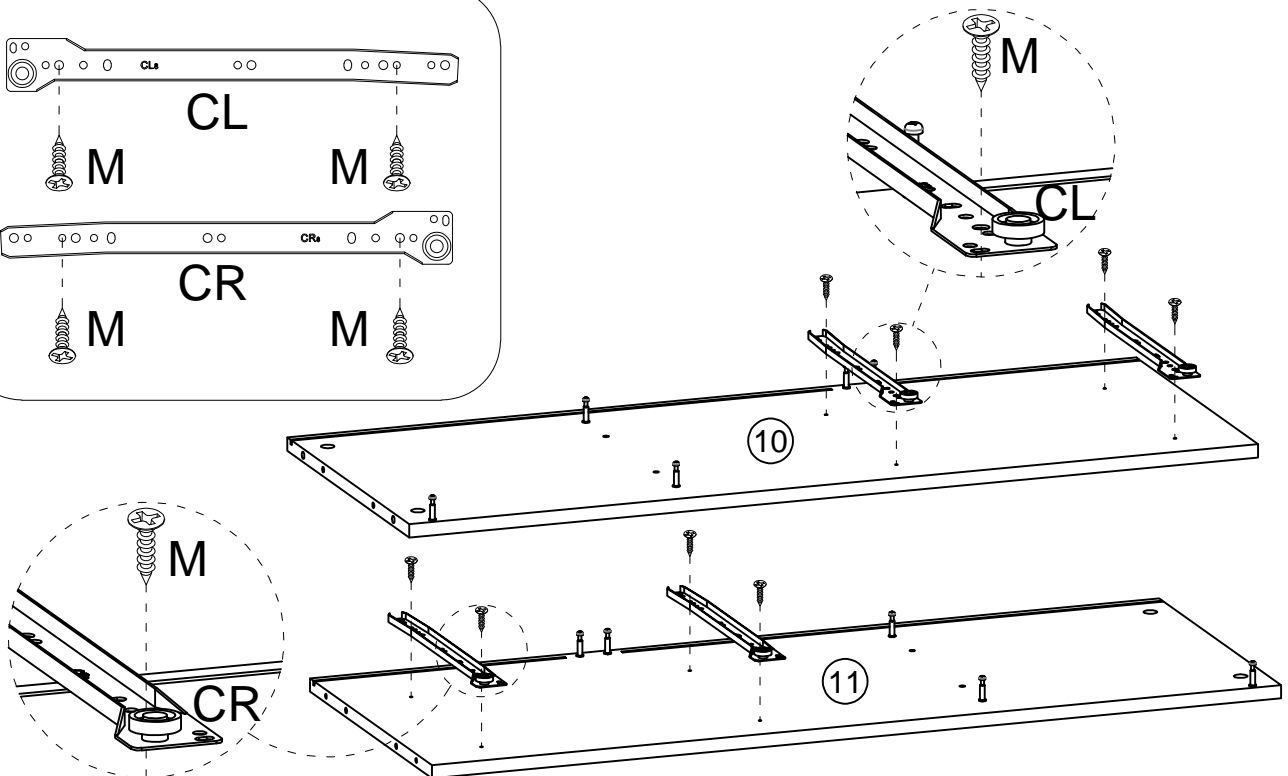
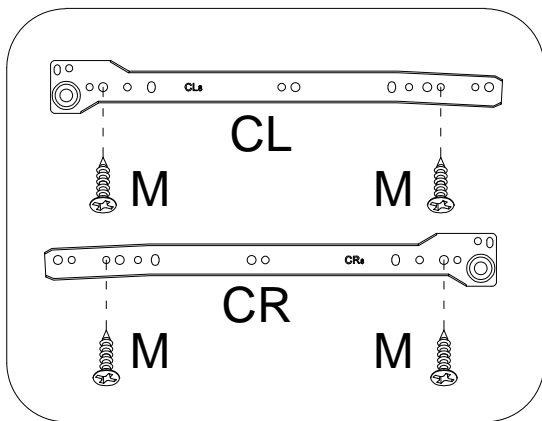
		
3.5×14mm	L300mm	L300mm
M ×8pcs	CL ×2pcs	CR ×2pcs



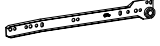

Step 5 Schritt 5

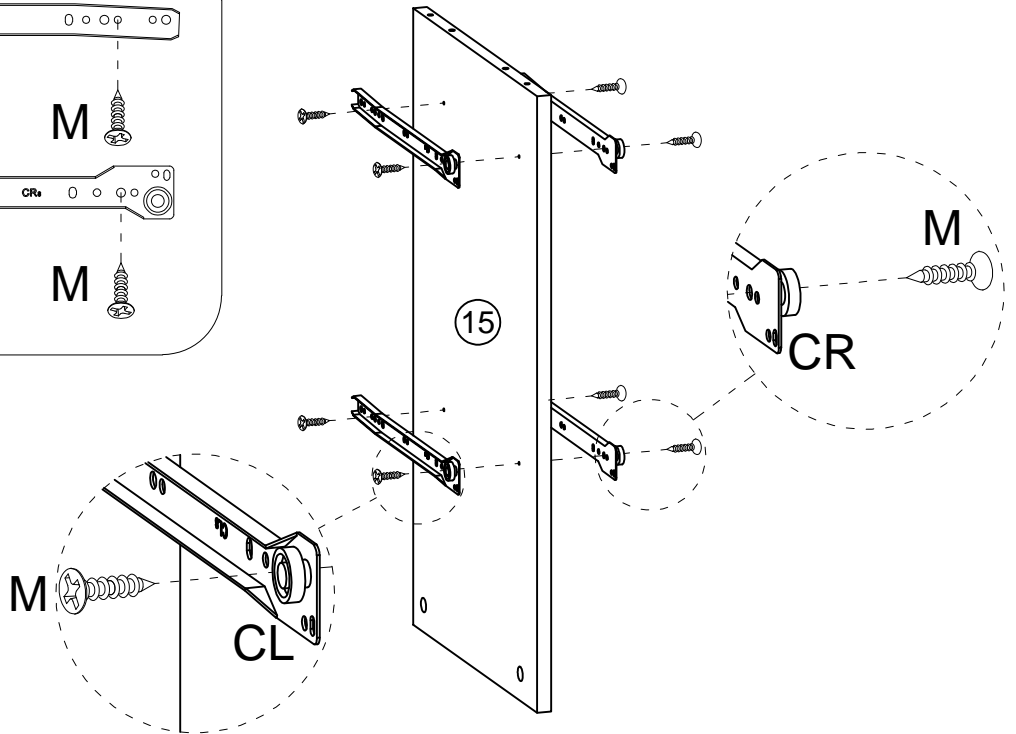
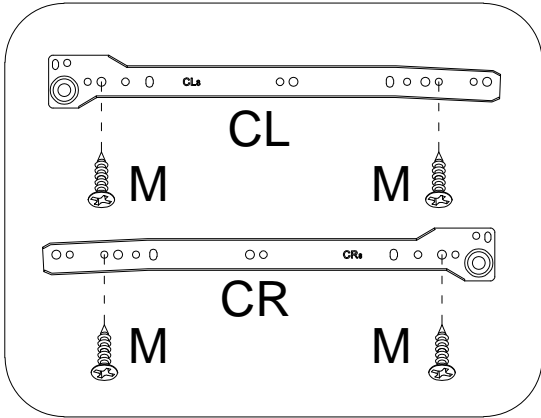
		
3.5×14mm	L300mm	L300mm
M ×8pcs	CL ×2pcs	CR ×2pcs

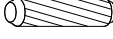

Step 6 Schritt 6

	
Ø6×30mm	Ø15×12mm
D ×2pcs	B ×5pcs

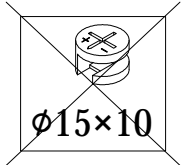
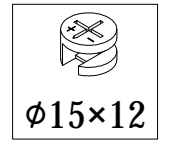
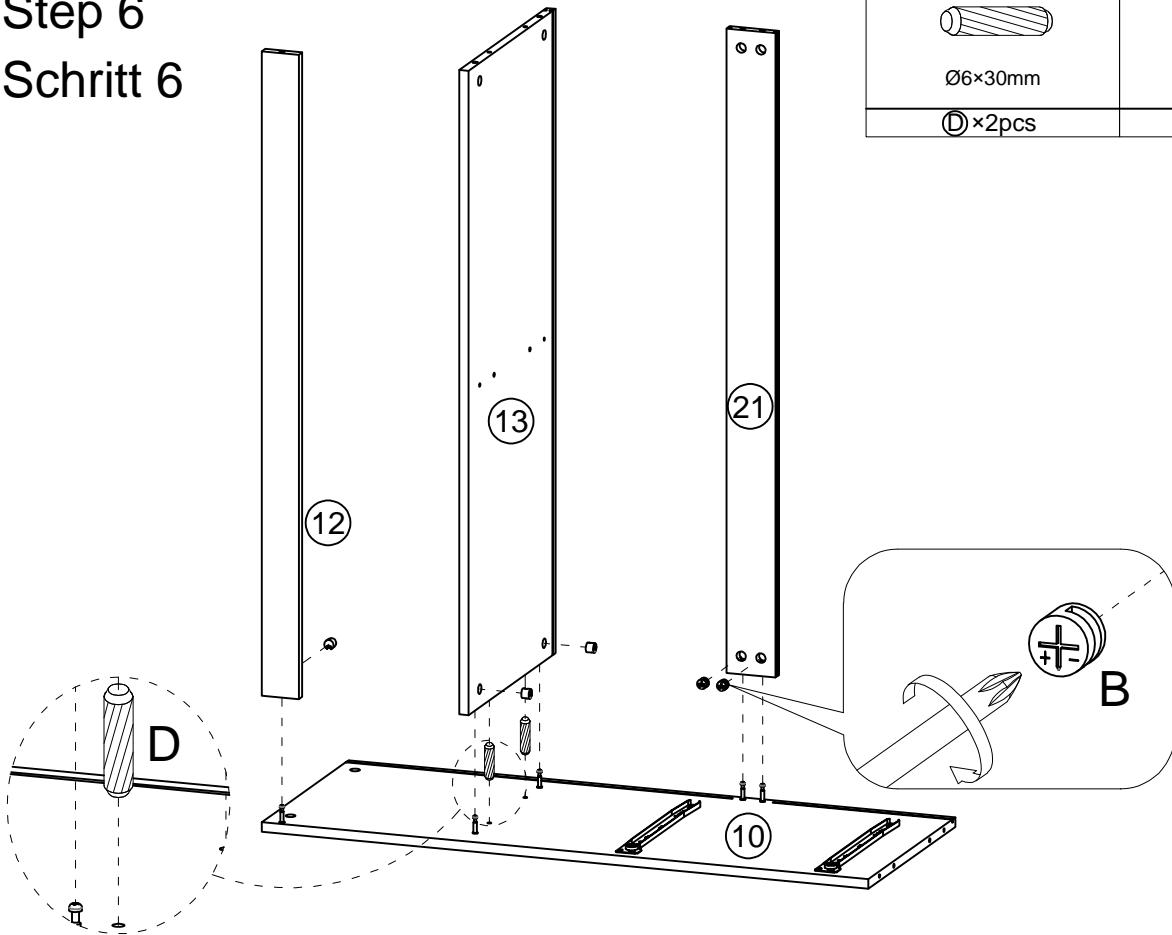

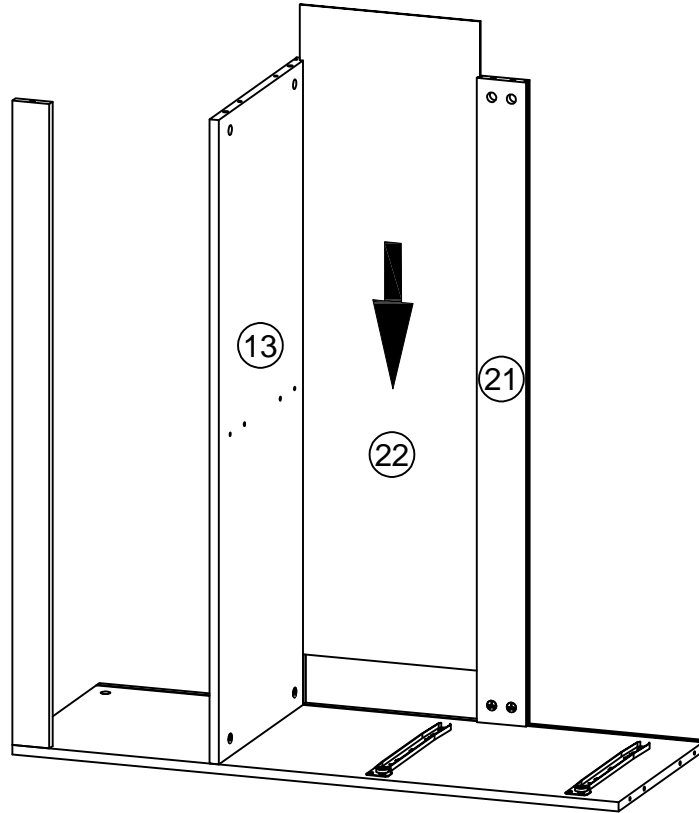

Step 7
Schritt 7

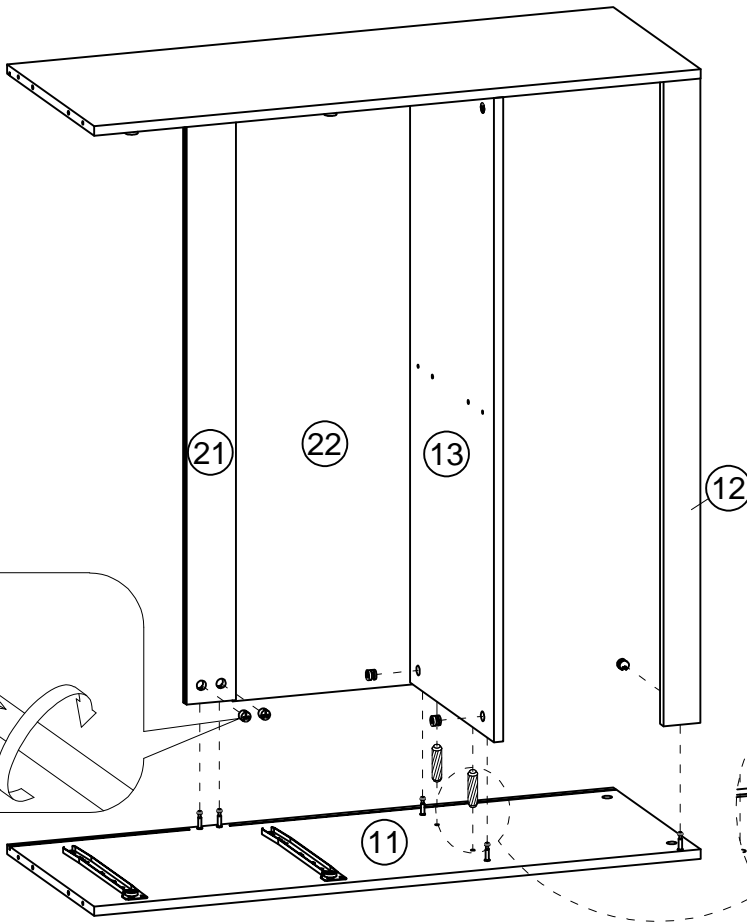

Step 8
Schritt 8

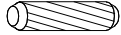



Ø15×12mm
Ⓑ×5pcs

Ø6×30mm
Ⓓ×2pcs

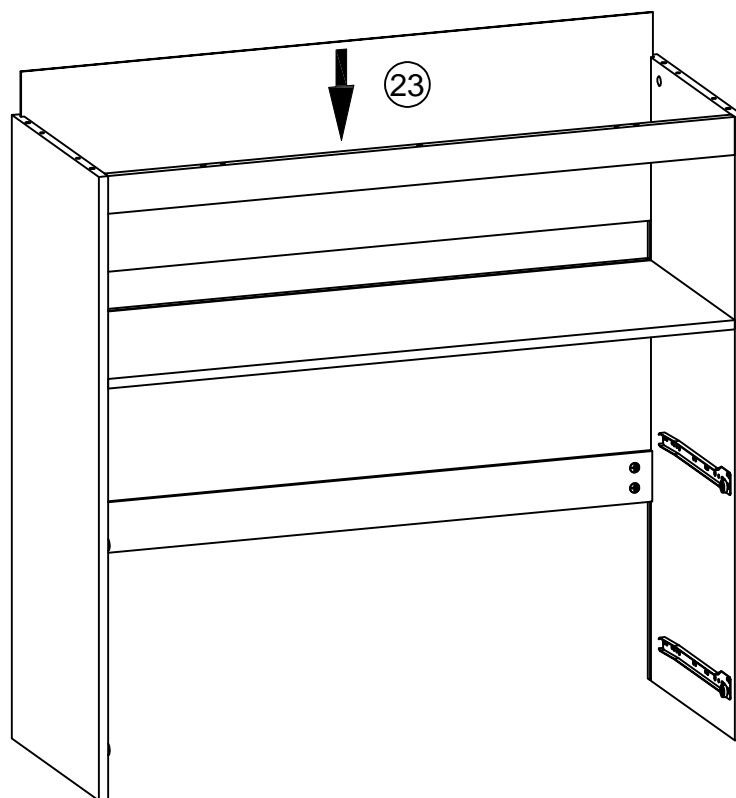

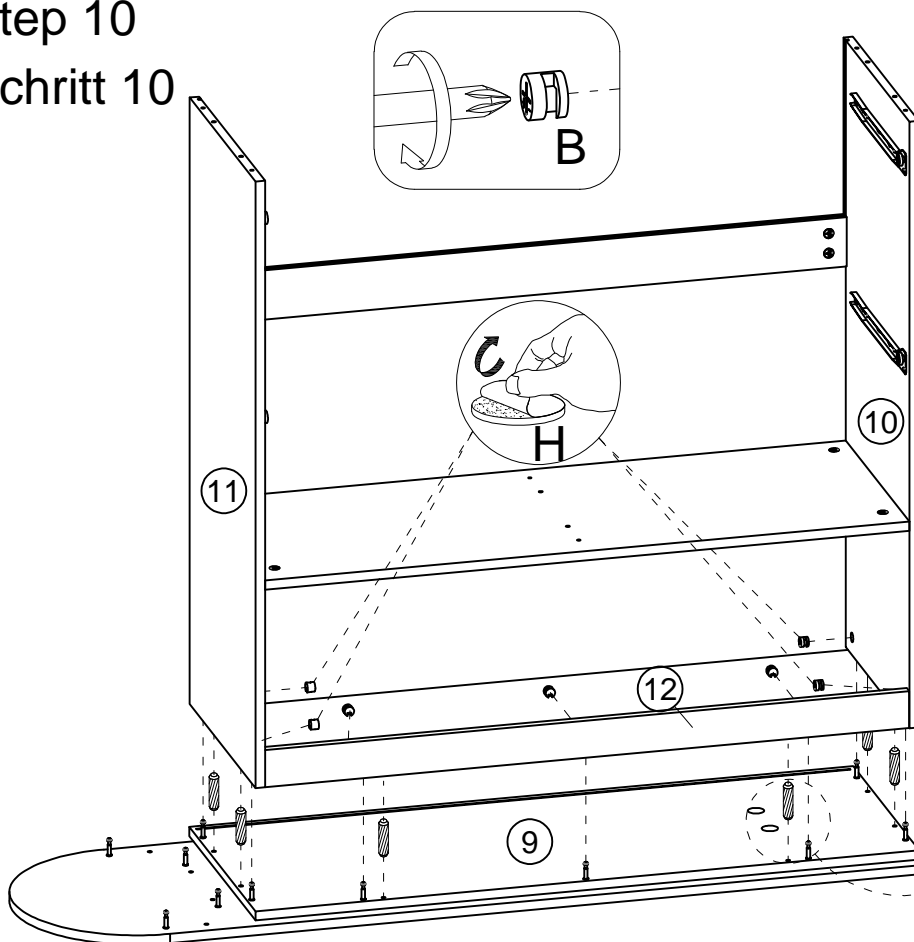

Ø15×12

Ø15×10



Step 9
Schritt 9



Step 10
Schritt 10





Ø15×12mm
ⓑ×7pcs

Ø6×30mm
Ⓓ×6pcs

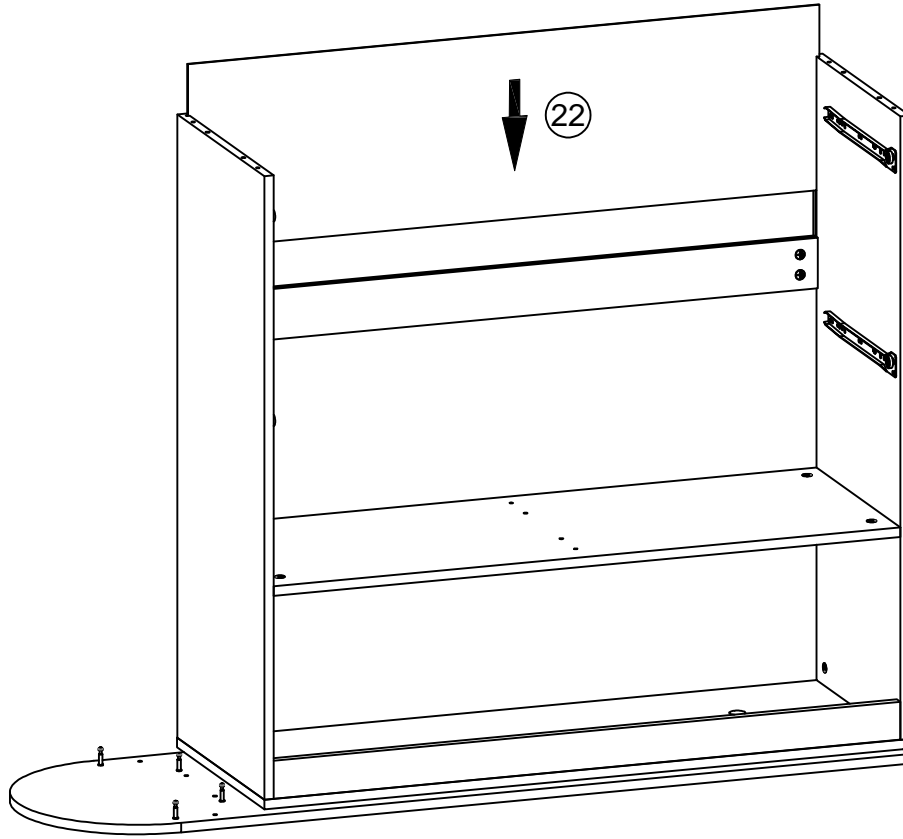
ⓓ×4pcs

	Ø15×12
	Ø15×10

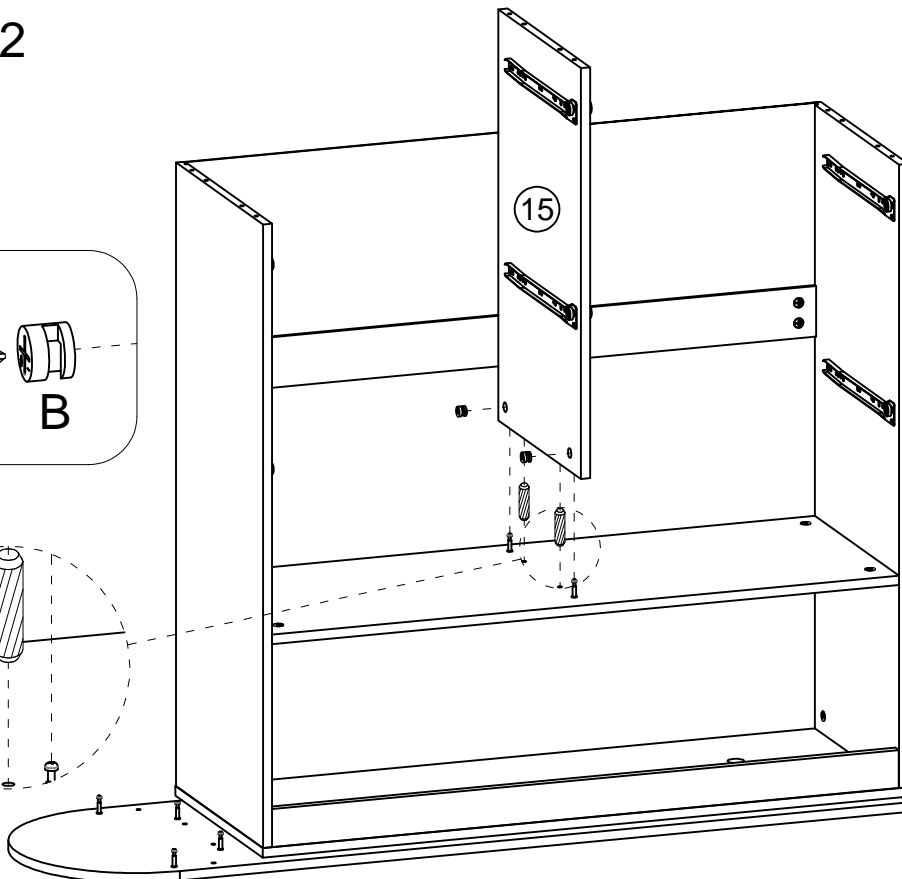
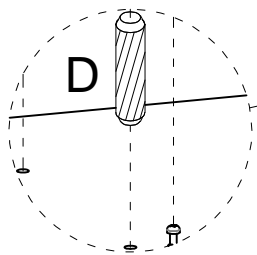
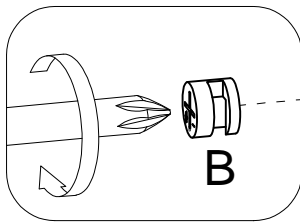
Step 11
Schritt 11



Step 12
Schritt 12



Ø15×12mm

ⓑ×2pcs



Ø6×30mm

Ⓓ×2pcs



Ø15×12



Ø15×10

Step 13
Schritt 13

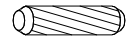
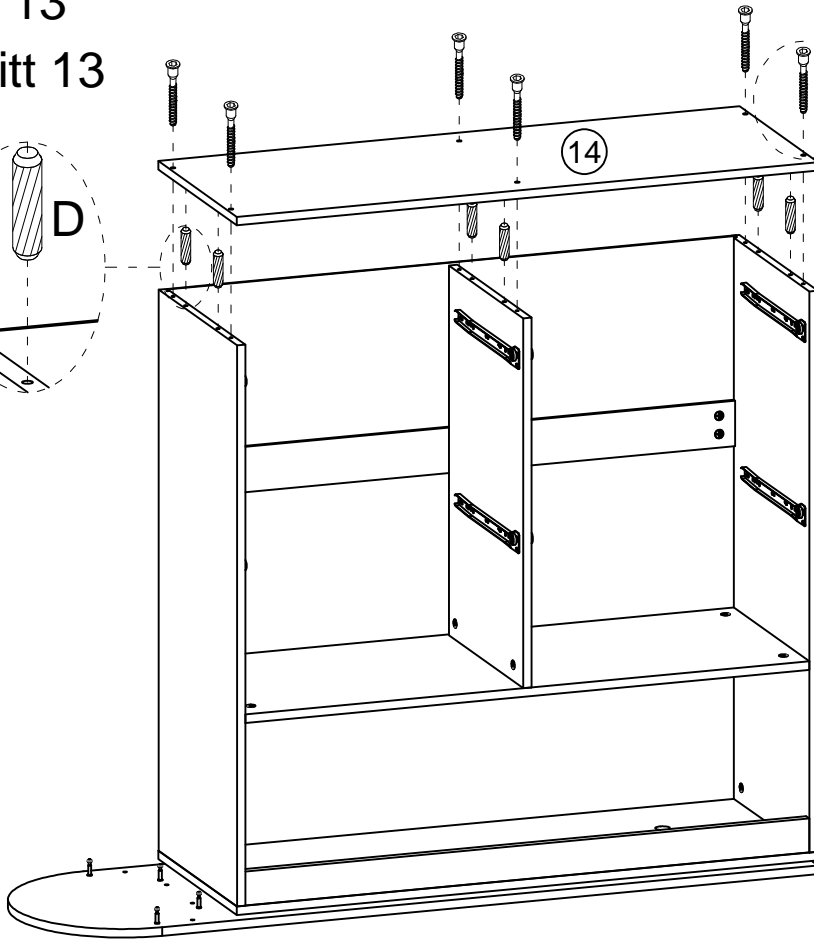
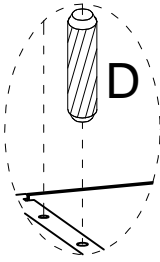

Ø6×30mm

ⓓ×6pcs



Ø7×40mm

Ⓞ×6pcs

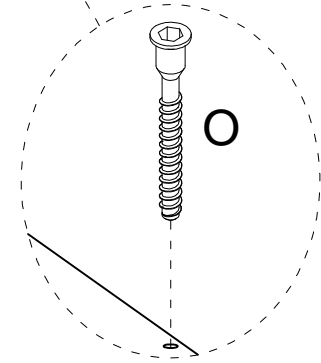

Step 14
Schritt 14



Ø15×10mm

Ⓞ×1pc

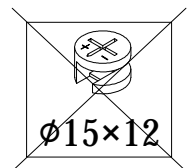
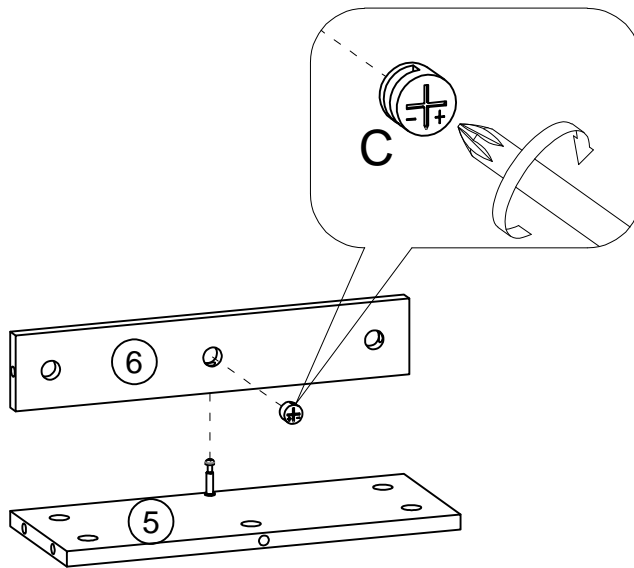

Ø15×12

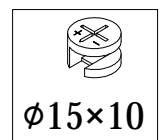



Ø15×10

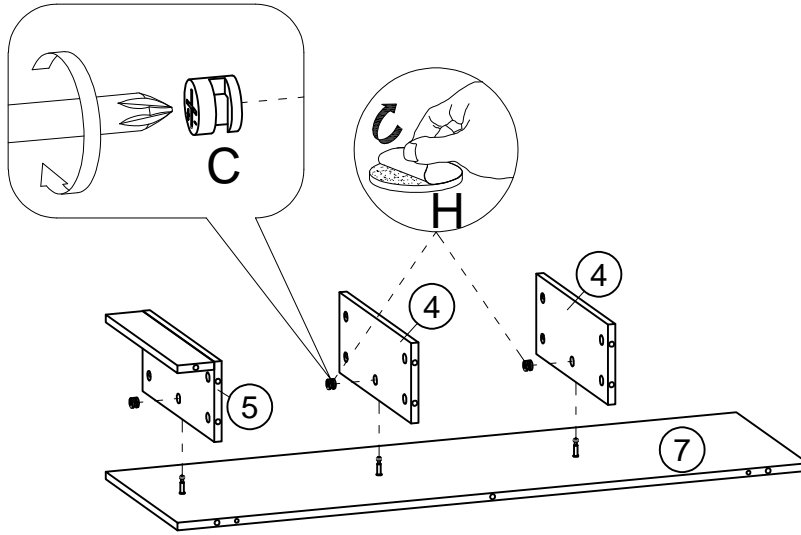

Step 15 Schritt 15

	
$\text{H} \times 2\text{pcs}$	$\text{C} \times 3\text{pcs}$





$\text{C} \times 3\text{pcs}$
$\text{H} \times 2\text{pcs}$

$\text{C} \times 3\text{pcs}$

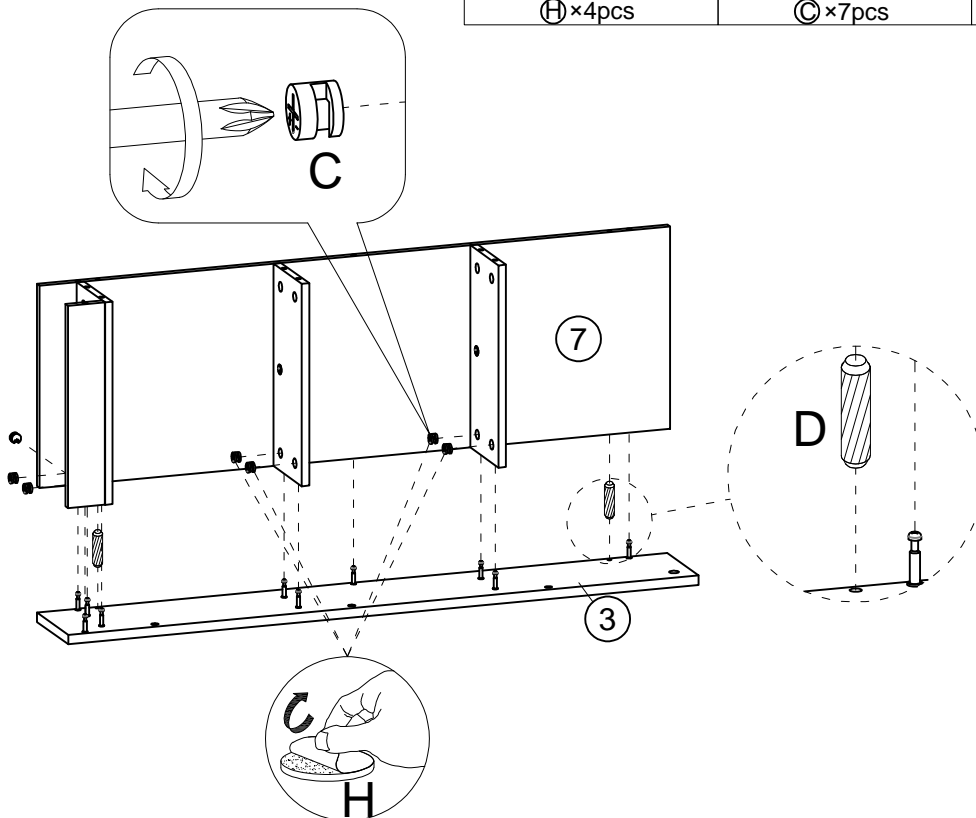

Step 16 Schritt 16

		
$\text{H} \times 4\text{pcs}$	$\text{C} \times 7\text{pcs}$	$\text{D} \times 2\text{pcs}$



$\text{C} \times 7\text{pcs}$
$\text{H} \times 4\text{pcs}$
$\text{D} \times 2\text{pcs}$

$\text{C} \times 7\text{pcs}$

Step 17
Schritt 17

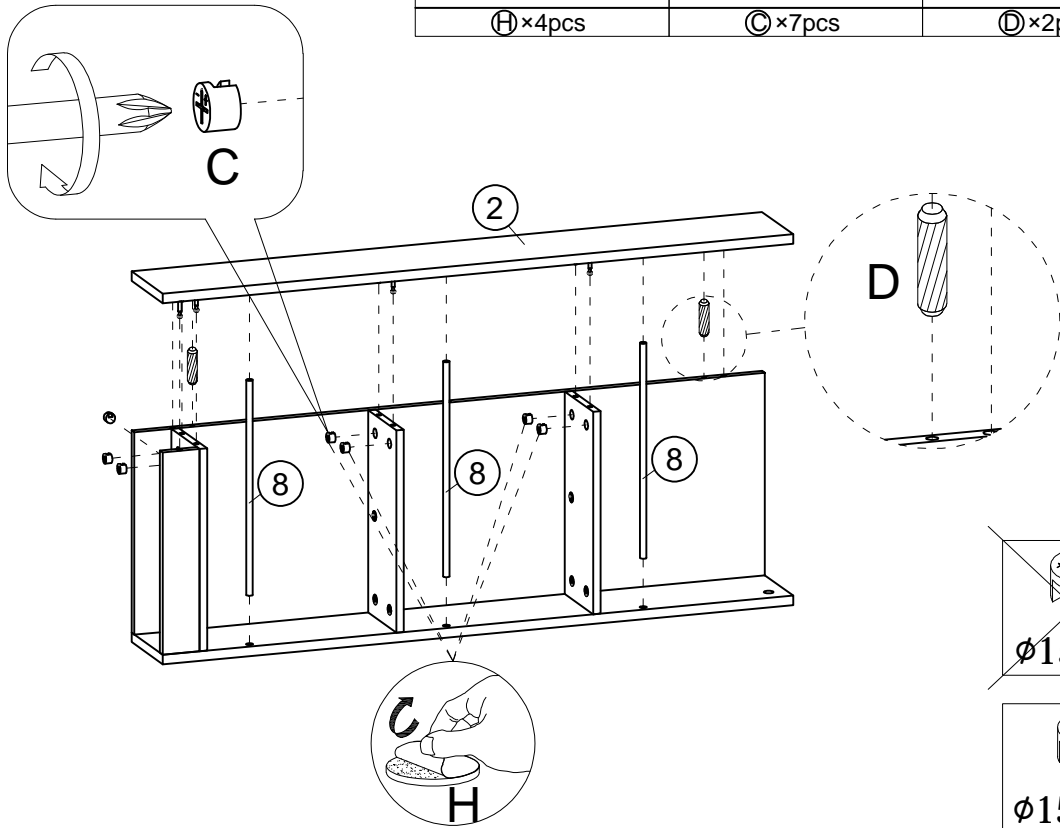
		
	Ø15×10mm	Ø6×30mm
Ⓜ×4pcs	Ⓒ×7pcs	Ⓓ×2pcs







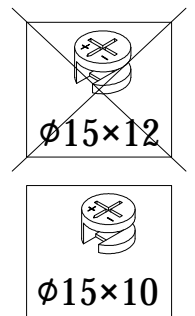
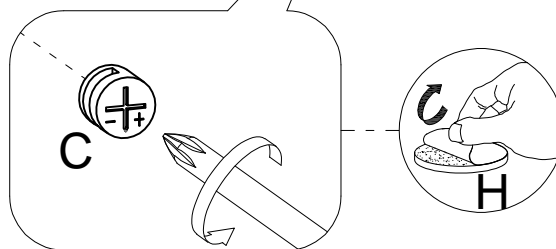
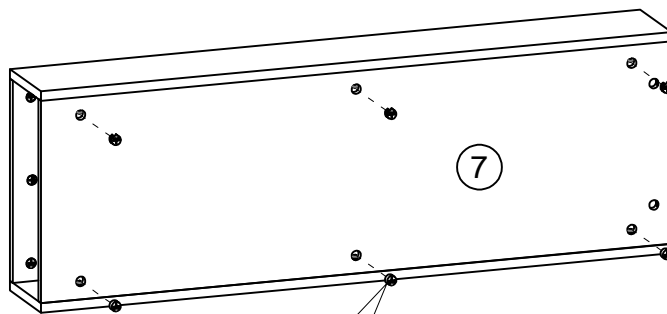

Step 18
Schritt 18

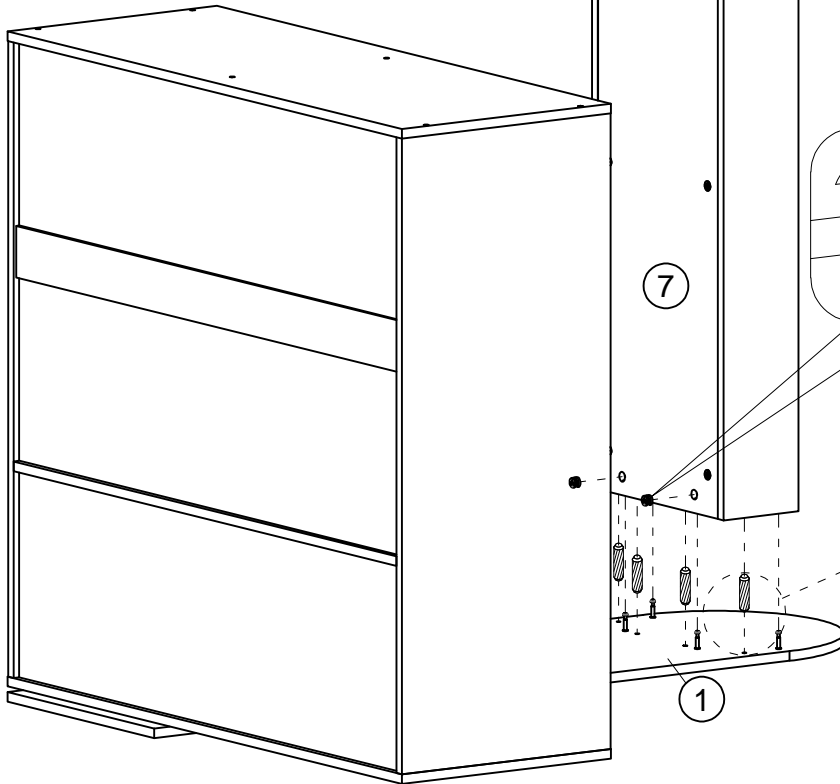
	
	Ø15×10mm
Ⓜ×6pcs	Ⓒ×6pcs



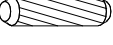

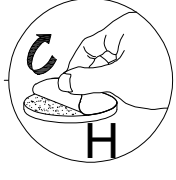
Step 19 Schritt 19



 Ø15×10mm ⓐ×2pcs	 Ø6×30mm ⓓ×4pcs
	 ⓗ×2pcs
	 ⓐ
	 Ø15×12
	 Ø15×10

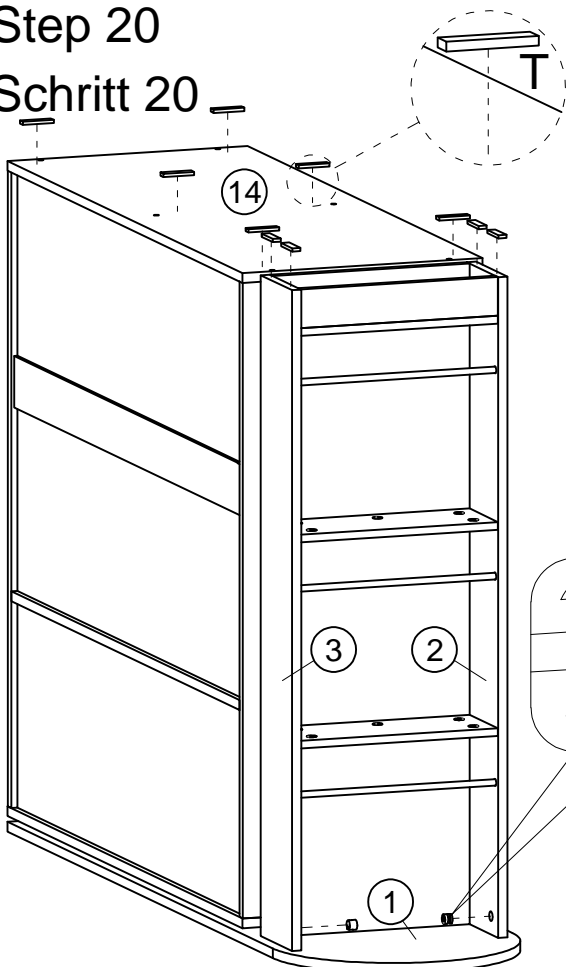

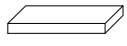
Step 20 Schritt 20



 13×50×5mm Ⓣ×10pcs	 ⓗ×2pcs	 Ø15×12mm ⓑ×2pcs
---	---	---

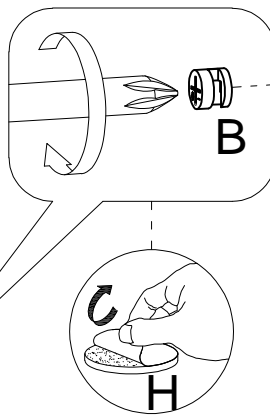

DE: Bitte drehen Sie das Produkt gemäß den folgenden Anweisungen um 180 Grad, um Verletzungen oder Schäden am Produkt zu vermeiden, bevor Sie mit der nächsten Installationsschritt fortfahren.
 UK: Please flip the product 180 degrees according to the following instructions to avoid injury or product damage before proceeding to the next installation step.
 FR: Pour éviter les blessures ou les dommages au produit, veuillez retourner le produit de 180 degrés selon les instructions suivantes avant de passer à l'étape d'installation suivante.



 Ø15×12
 Ø15×10

Step 21

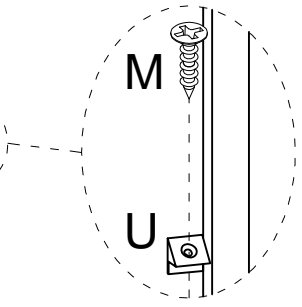
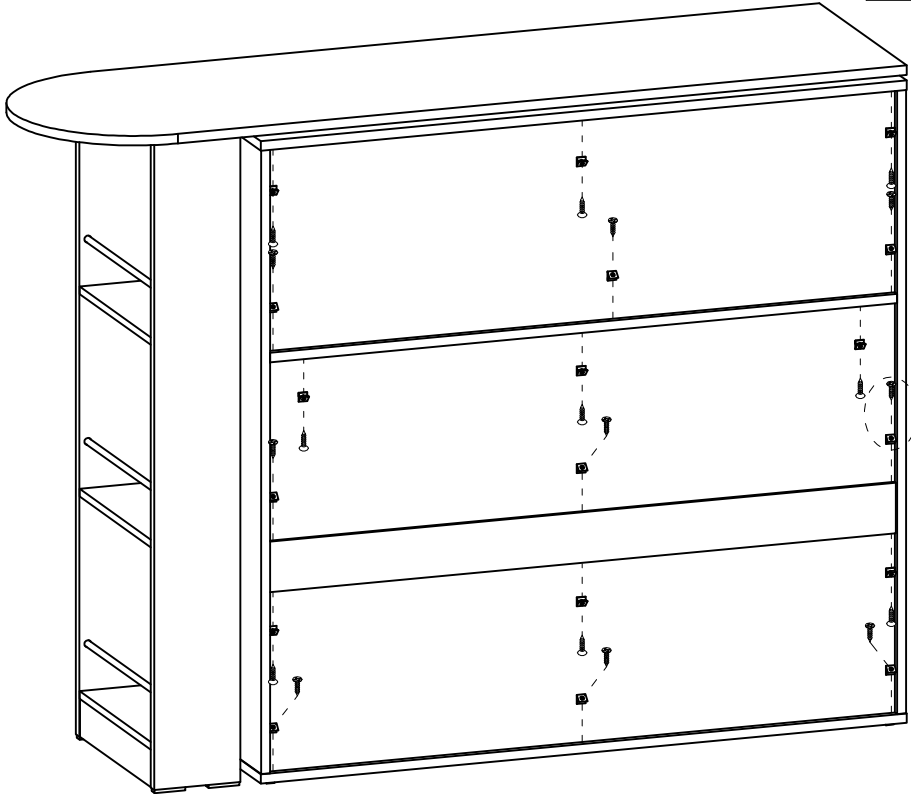

Schritt 21

	
14×14×9mm	3.5×14mm
U×18pcs	M×18pcs



Step 22

Schritt 22

		
	M4×22mm	Ø15×10mm
E×4pcs	F×4pcs	C×16pcs

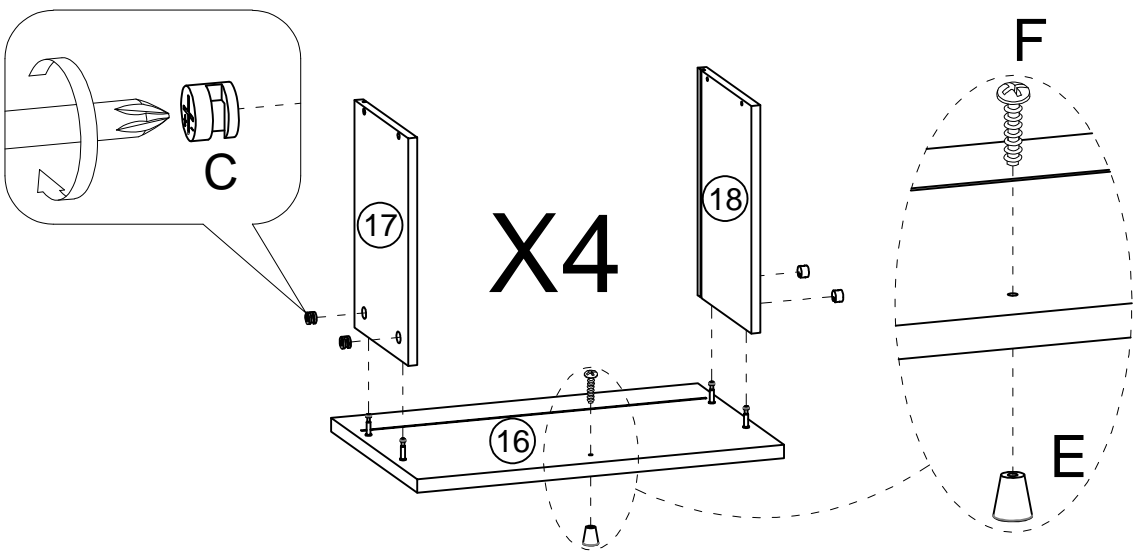

Step 23
Schritt 23

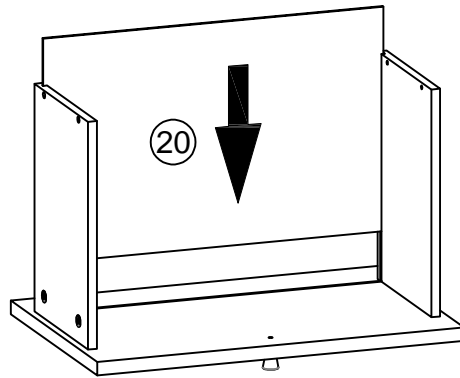

X4

Step 24
Schritt 24

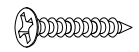

4×35mm

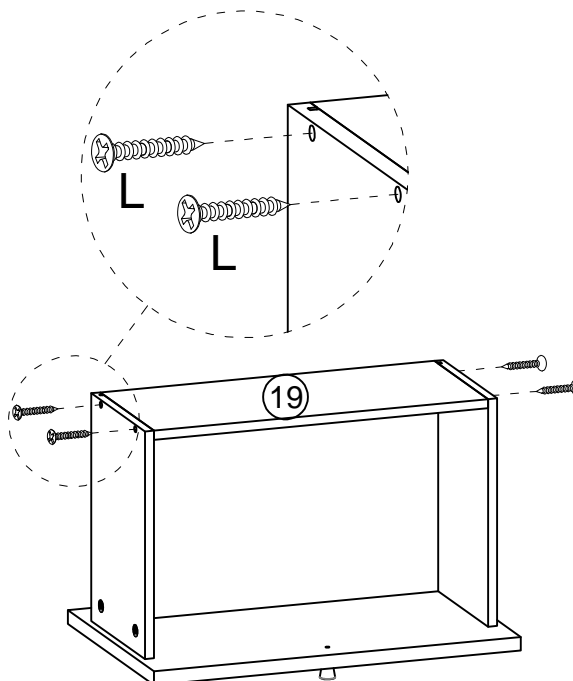

Ⓛ×16pcs



X4

Step 25

Schritt 25

 3.5×14mm	 L300mm	 L300mm
Ⓜ ×16pcs	Ⓛ ×4pcs	Ⓜ ×4pcs

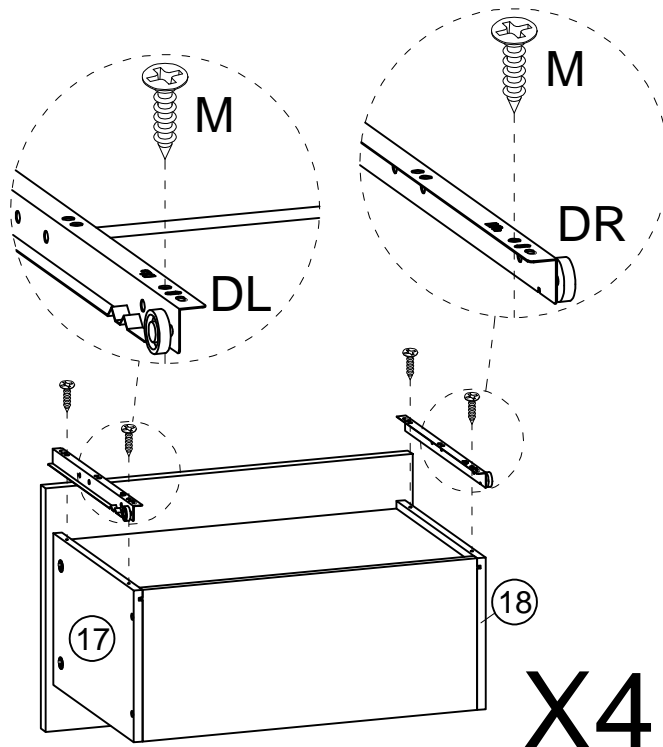
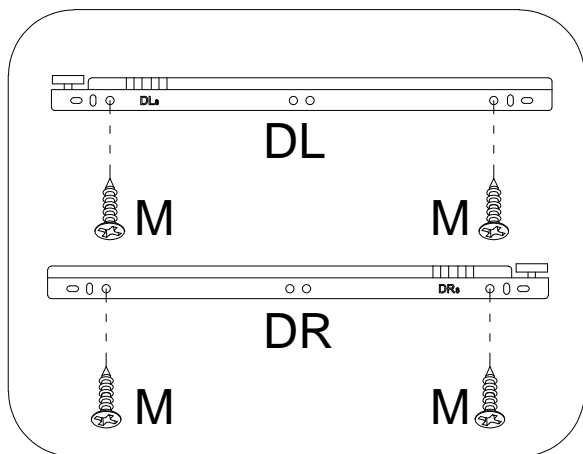

Step 26

Schritt 26

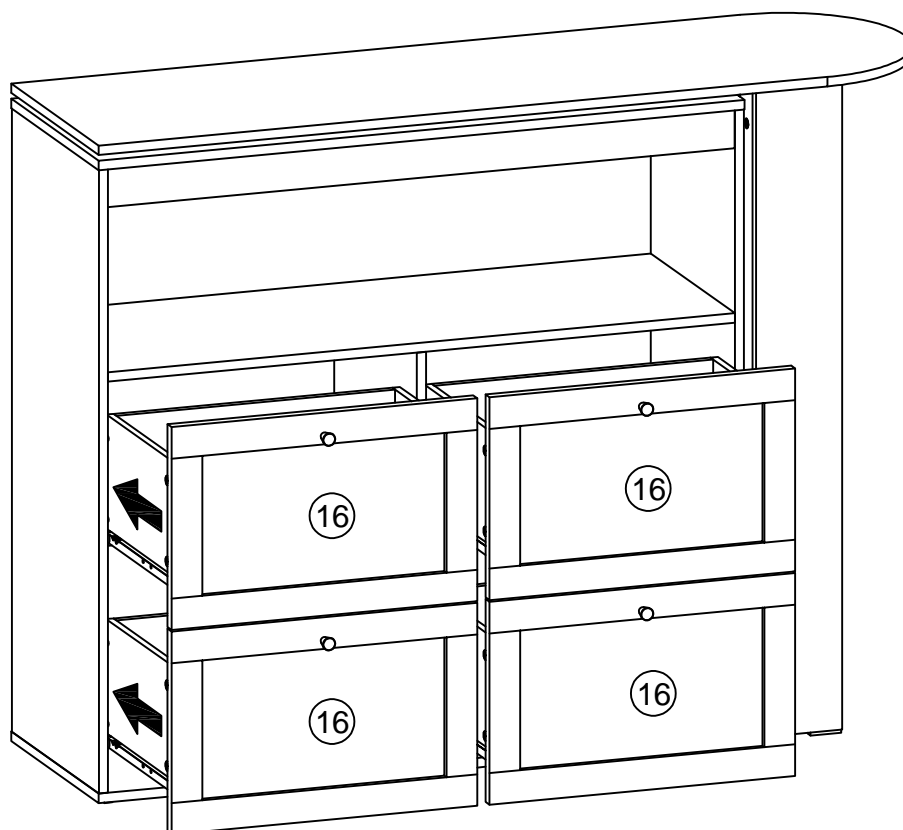



DE

Warnung

1. Die maximale Tragfähigkeit der Produktoberplatte beträgt 60 kg. Überlastung vermeiden.
2. Bitte Kinder nicht auf das Möbel klettern lassen, da dies zu Umkippen und schweren Verletzungen führen kann.
3. Zur Sicherheit bitte die Anweisungen korrekt befolgen und gegebenenfalls professionelle Hilfe in Anspruch nehmen.
4. Das Möbel nicht in der Nähe von Hitzequellen oder heißen Gegenständen platzieren, um Brandgefahr zu vermeiden.
5. Das Möbel nicht in feuchten Umgebungen aufstellen, um Schäden am Material zu vermeiden.
6. Regelmäßige Überprüfung aller Verbindungsstücke und Befestigungen, um sicherzustellen, dass sie fest sitzen und unerwartete Unfälle zu verhindern.
7. Das Produkt ist mit einem Kippschutz ausgestattet, um Verletzungen durch Umkippen zu verhindern.

UK

Warning

- 1 The maximum load-bearing capacity of the product top panel is 60 kg. Do not overload.
- 2 Please do not allow children to climb on furniture, as this may result in tipping and serious injuries.
- 3 For safety, please follow the instructions correctly and seek professional assistance if necessary.
- 4 Do not place furniture near heat sources or hot items to avoid the risk of fire.
- 5 Do not place furniture in damp environments to prevent material damage.
- 6 Regularly check all fittings and fastenings to ensure they are secure and to prevent accidents.
- 7 This product comes with an anti-tip device to prevent injuries from tipping.

FR

Avertissement

- 1 La capacité de charge maximale du plateau supérieur du produit est de 60 kg. Ne pas surcharger.
- 2 Veuillez ne pas laisser les enfants grimper sur les meubles, car cela peut entraîner un basculement et des blessures graves.
- 3 Pour des raisons de sécurité, veuillez suivre correctement les instructions et demander de l'aide professionnelle si nécessaire.
- 4 Ne pas placer les meubles près de sources de chaleur ou d'objets chauds pour éviter tout risque d'incendie.
- 5 Ne pas placer les meubles dans des environnements humides pour éviter les dommages matériels.
- 6 Vérifiez régulièrement tous les raccords et fixations pour vous assurer qu'ils sont bien serrés et pour éviter les accidents.
- 7 Ce produit est équipé d'un dispositif anti-basculement pour éviter les blessures en cas de basculement.

IT

Avviso

- 1 La capacità massima di carico del piano superiore del prodotto è di 60 kg. Non sovraccaricare.
- 2 Si prega di non permettere ai bambini di arrampicarsi sui mobili, poiché ciò potrebbe causare il ribaltamento e gravi lesioni.
- 3 Per motivi di sicurezza, seguire correttamente le istruzioni e richiedere assistenza professionale se necessario.
- 4 Non posizionare i mobili vicino a fonti di calore o oggetti caldi per evitare il rischio di incendio.
- 5 Non posizionare i mobili in ambienti umidi per evitare danni al materiale.
- 6 Controllare regolarmente tutti i raccordi e i fissaggi per assicurarsi che siano saldi e per evitare incidenti.
- 7 Questo prodotto è dotato di un dispositivo anti-ribaltamento per evitare lesioni dovute al ribaltamento.

ES

Aviso

- 1 La capacidad máxima de carga del panel superior del producto es de 60 kg. No sobrecargar.
- 2 Por favor, no permita que los niños trepen sobre los muebles, ya que esto podría provocar que se vuelquen y causar lesiones graves.
- 3 Por seguridad, siga correctamente las instrucciones y solicite ayuda profesional si es necesario.
- 4 No coloque los muebles cerca de fuentes de calor o objetos calientes para evitar el riesgo de incendio.
- 5 No coloque los muebles en entornos húmedos para evitar daños en el material.
- 6 Revise regularmente todas las conexiones y sujeciones para asegurarse de que estén firmes y para evitar accidentes.
- 7 Este producto viene con un dispositivo antivuelco para evitar lesiones por vuelco.