

MONTAGEANLEITUNG

Artikelnummer: WF305992WAA
WF305993WAA
WF305994WAA

Dieses Set ist in 3 Boxen enthalten. Wenn Sie keine vollen 3 Boxen erhalten wenden Sie sich bitte an unseren Kundenservice.

This set comes in 3 boxes. If you do not receive a full 3 boxes, please contact our customer service.

hausbett 200x90cm

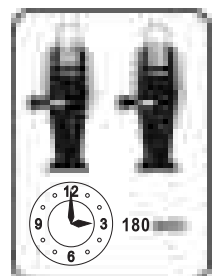
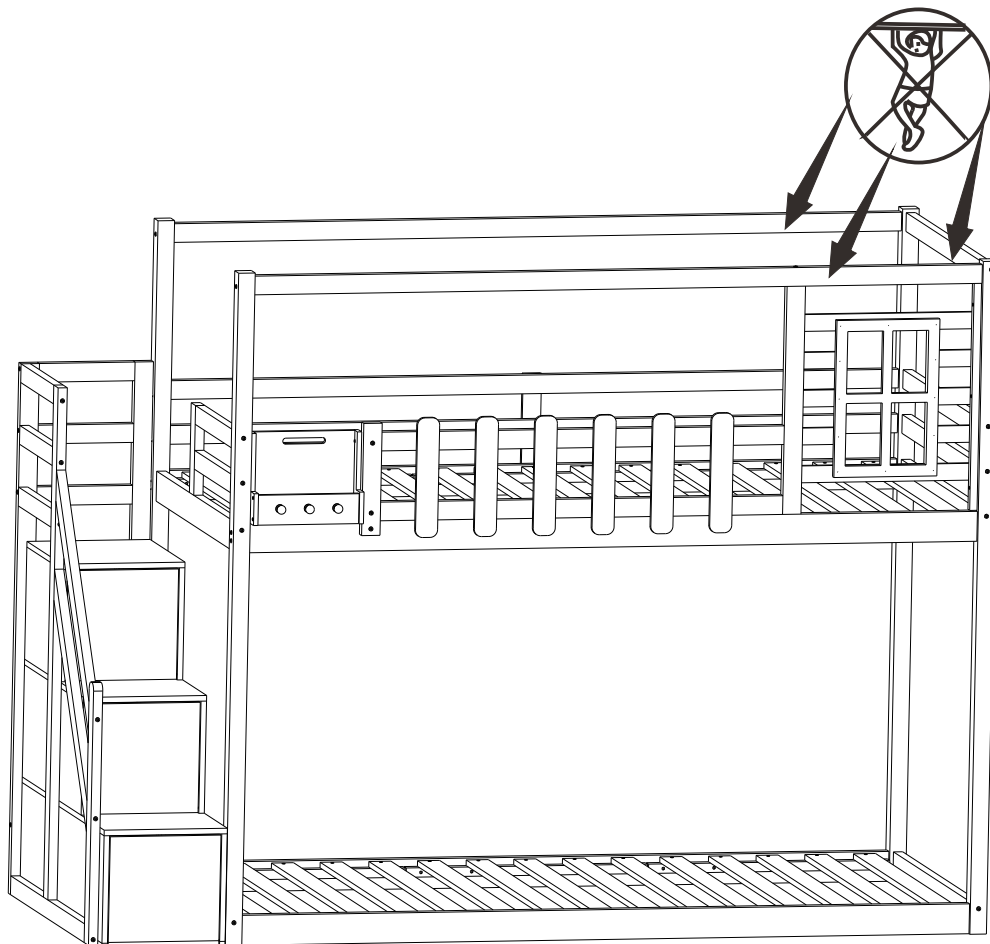

INSTRUCTIONS

IMPORTANT-READ CAREFULLY-RETAIN FOR FUTURE REFERENCE

- a) **WARNING** -Children can become trapped between the bed and the wall, the adjoining pieces of furniture (e.g. cupboards) and the Ikea. To avoid risk of serious injury the distance between the safety barrier and the adjoining structure shall not exceed 75 mm or shall be more than 230 mm.
- b) **WARNING**-Do not use the bed if any structural part is broken or missing; Replacement parts are between requested from the manufacturer or the store.
- c) **WARNING**-Do not climb or wiggle on any non-designated structures.
- d) it is imperative to always follow the installation instructions and manufacturer's use.
- e) The recommended size of the mattress to be used with the bed is 200cmx90cm,maximum thickness mattress:13cm.
- f) It is necessary to ventilate the room in order to maintain a low level moisture and prevent mold growth in the bed and its periphery.
- g) Joining devices should always be tightened properly and regularly verified. Tighten if necessary.

ANLEITUNGEN

WICHTIG - SORGFÄLTIG LESEN - FÜR SPÄTERE VERWENDUNGAUFBEWAHREN

- a) **WARNUNG** - Kinder können zwischen dem Bett und der Wand, den angrenzenden Möbelstücken (z. B. Schränken) und der Lücke eingeklemmt werden. Um die Gefahr schwerer Verletzungen zu vermeiden, darf der Abstand zwischen der Sicherheitsbarriere und der angrenzenden Struktur nicht mehr als 75 mm oder mehr als 230 mm betragen.
- b) **WARNUNG**-Das Bett darf nicht benutzt werden, wenn ein Bauteil gebrochen ist oder fehlt; Ersatzteile sind beim Hersteller oder im Geschäft anzufordern.
- c) **WARNUNG** - Klettern oder wackeln Sie nicht auf nicht dafür vorgesehenen Strukturen.
- d) Befolgen Sie unbedingt die Installationsanweisungen und die Gebrauchsanweisungen des Herstellers.
- e) Die empfohlene Größe der Matratze für das Bett beträgt 90x200cm, maximale Dicke der Matratze: 13cm.
- f) Es ist notwendig, den Raum zu lüften, um die Feuchtigkeit niedrig zu halten und Schimmelbildung im Bett und seiner Umgebung zu verhindern.
- g) Die Verbindungselemente sollten immer richtig angezogen sein und regelmäßig überprüft werden. Ziehen Sie sie gegebenenfalls nach.

WF305992WAA

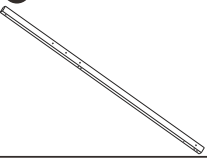
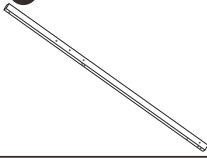
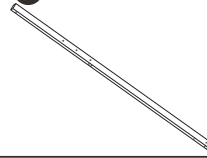
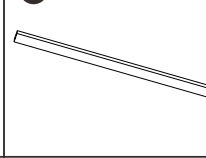
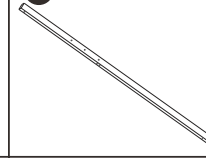
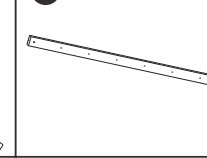
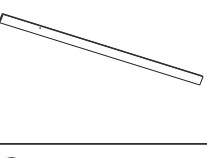
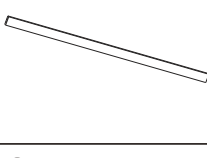
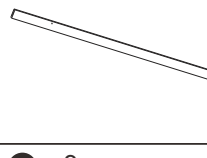
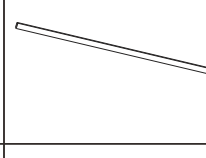
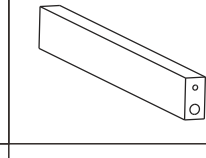
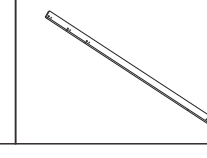
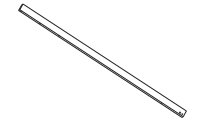
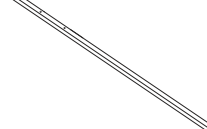
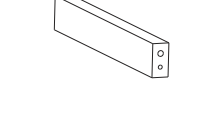
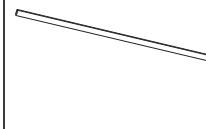
6 x1 	7 x1 	8 x1 	9 x1 	10 x1 	11 x2 
13 x1 	14 x2 	15 x1 	16 x2 	17 x2 	31 x1 
32 x1 	33 x1 	37 x3 	53 x1 		

WF305993WAA

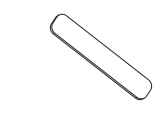
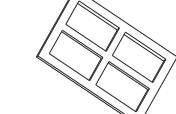
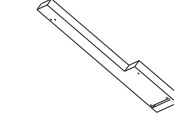
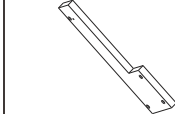
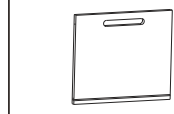
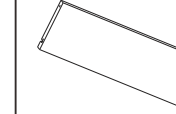
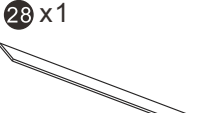
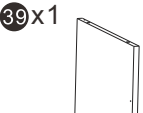
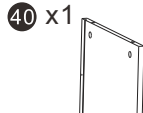
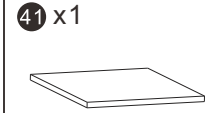
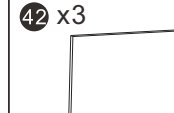
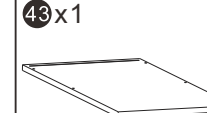
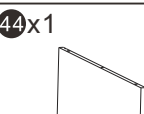
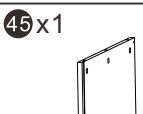
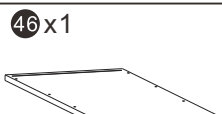
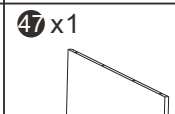
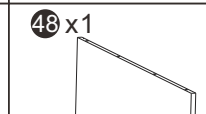
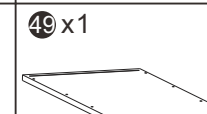
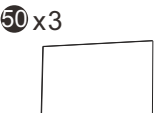



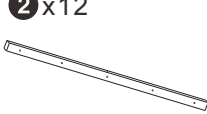
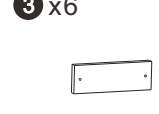
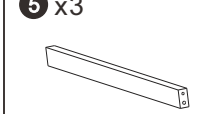
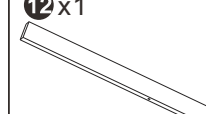
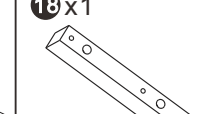
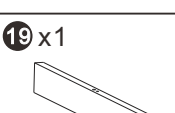
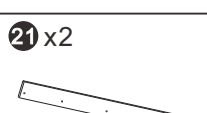
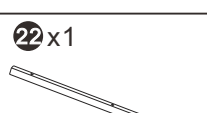
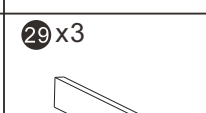
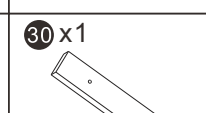
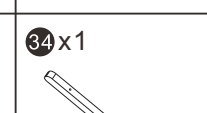
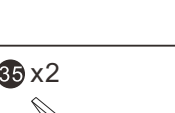
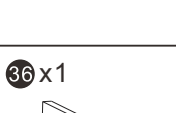
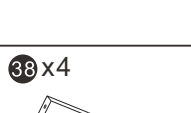
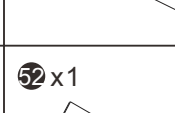







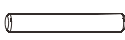

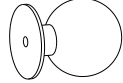

4 x6 	23 x1 	24 x1 	25 x1 	26 x1 	27 x1 
28 x1 	39 x1 	40 x1 	41 x1 	42 x3 	43 x1 
44 x1 	45 x1 	46 x1 	47 x1 	48 x1 	49 x1 
50 x3 					

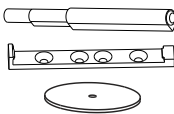
WF305994WAA

1 x30 	2 x12 	3 x6 	5 x3 	12 x1 	18 x1 
19 x1 	21 x2 	22 x1 	29 x3 	30 x1 	34 x1 
35 x2 	36 x1 	38 x4 	52 x1 		

Hardware-Liste



WF305994WAA

<p>Ax72</p>  <p>M6x70</p>	<p>Bx7</p>  <p>M6x40</p>	<p>Cx3</p>  <p>M6x30</p>	<p>Dx37</p>  <p>M8x40</p>	<p>Ex78</p>  <p>M4x30</p>	<p>Fx22</p>  <p>M4x20</p>
<p>Gx3</p>  <p>m4x20</p>	<p>Hx3</p> 	<p>Ix9</p>  <p>M3.5x12</p>	<p>Jx3</p> 	<p>Kx32</p> 	<p>Lx32</p> 
<p>Mx6</p> 	<p>Ox54</p>  <p>M4x35</p>	<p>Px1</p> 	<p>Qx8</p>  <p>M4x25</p>	<p>Rx2</p>  <p>M6x100</p>	

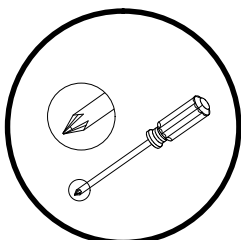
Benötigte Werkzeuge (nicht von uns gestellt)



Schritt 1

A		2
R		1

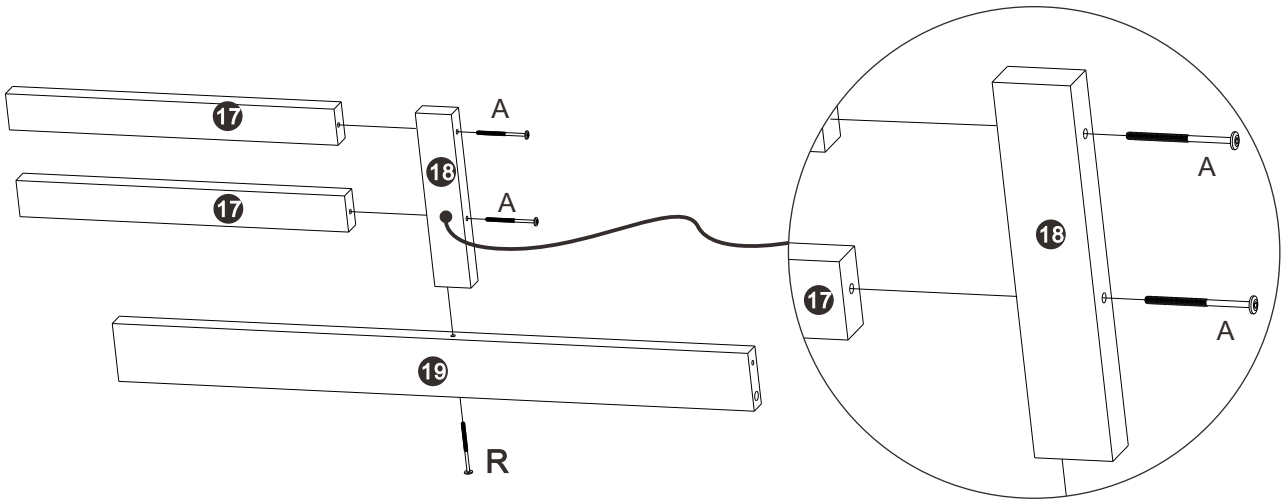

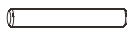

Schritt 2

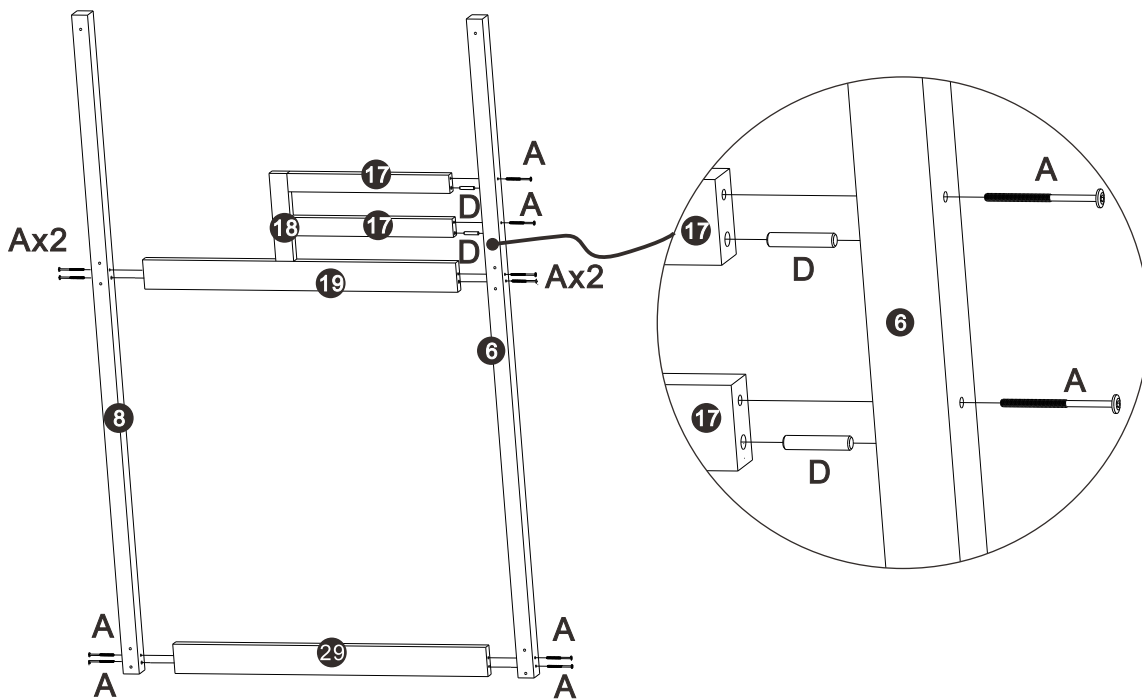
A		10
D		2



Schritt 3

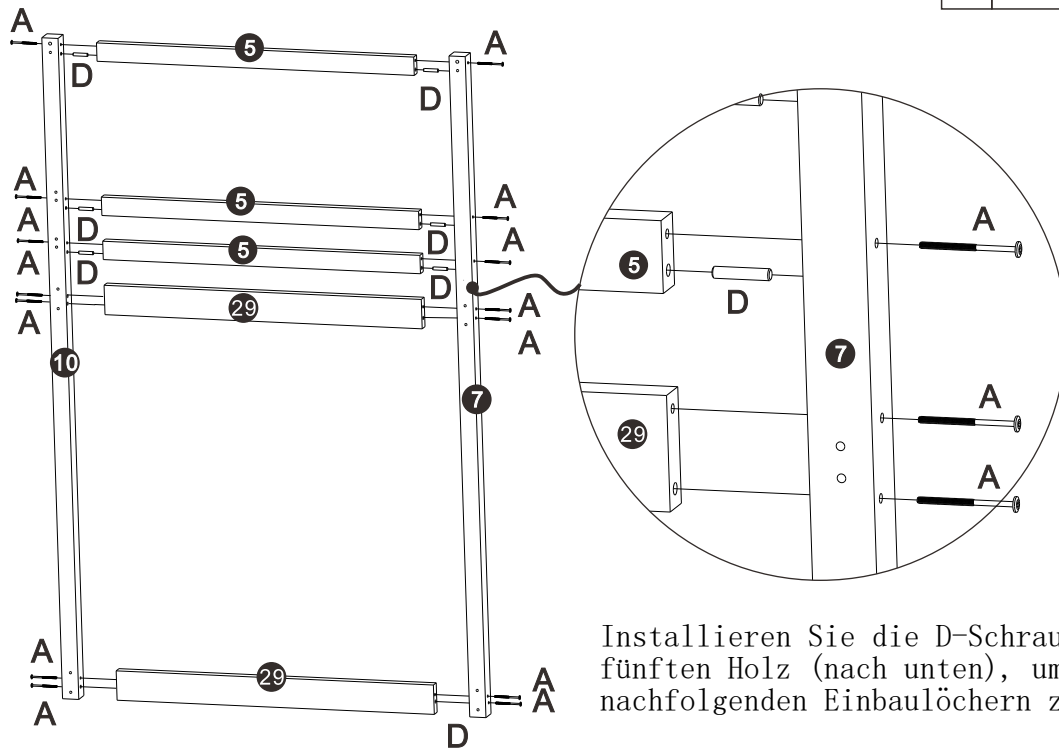

A		14
D		6



Installieren Sie die D-Schraube auf dem fünften Holz (nach unten), um Konflikte in nachfolgenden Einbaulöchern zu vermeiden

Install the D-type screw on the 5th wood (to the bottom) to avoid conflicts in subsequent installation holes

Schritt 4

G		3
H		3

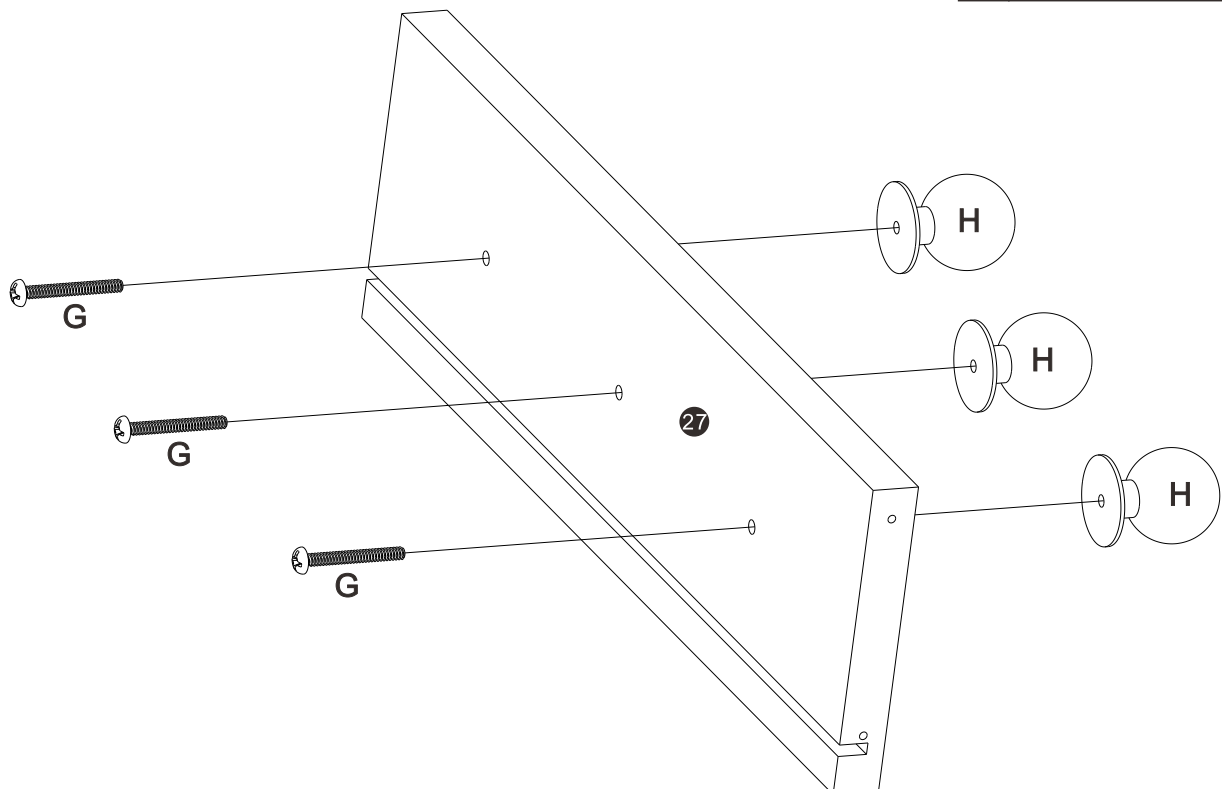

Schritt 5

Q



8

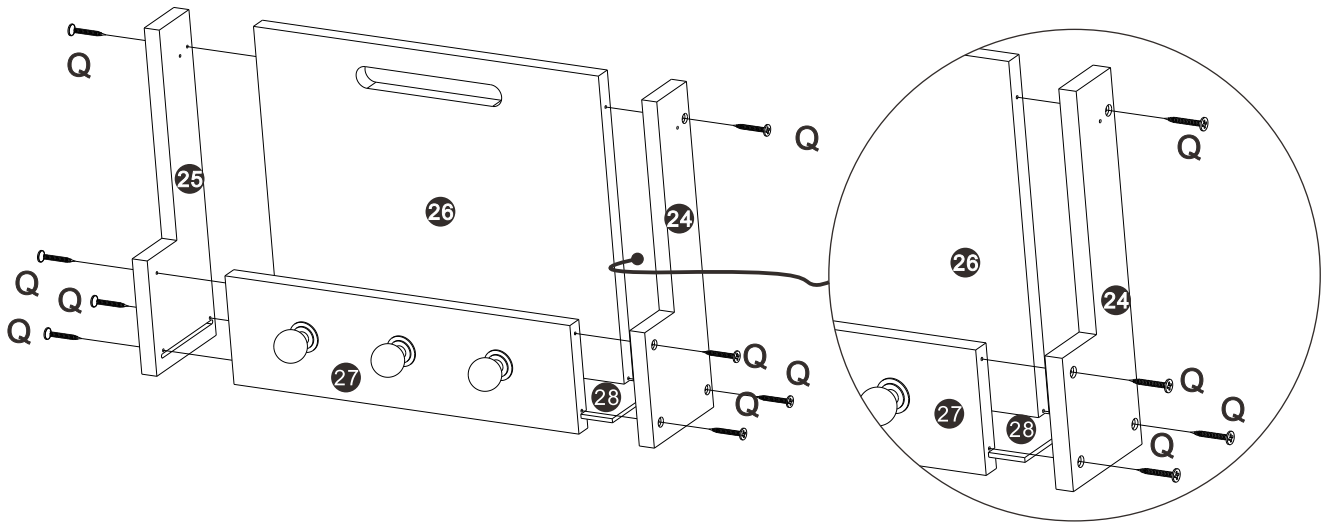

Schritt 6

A



2

B



2

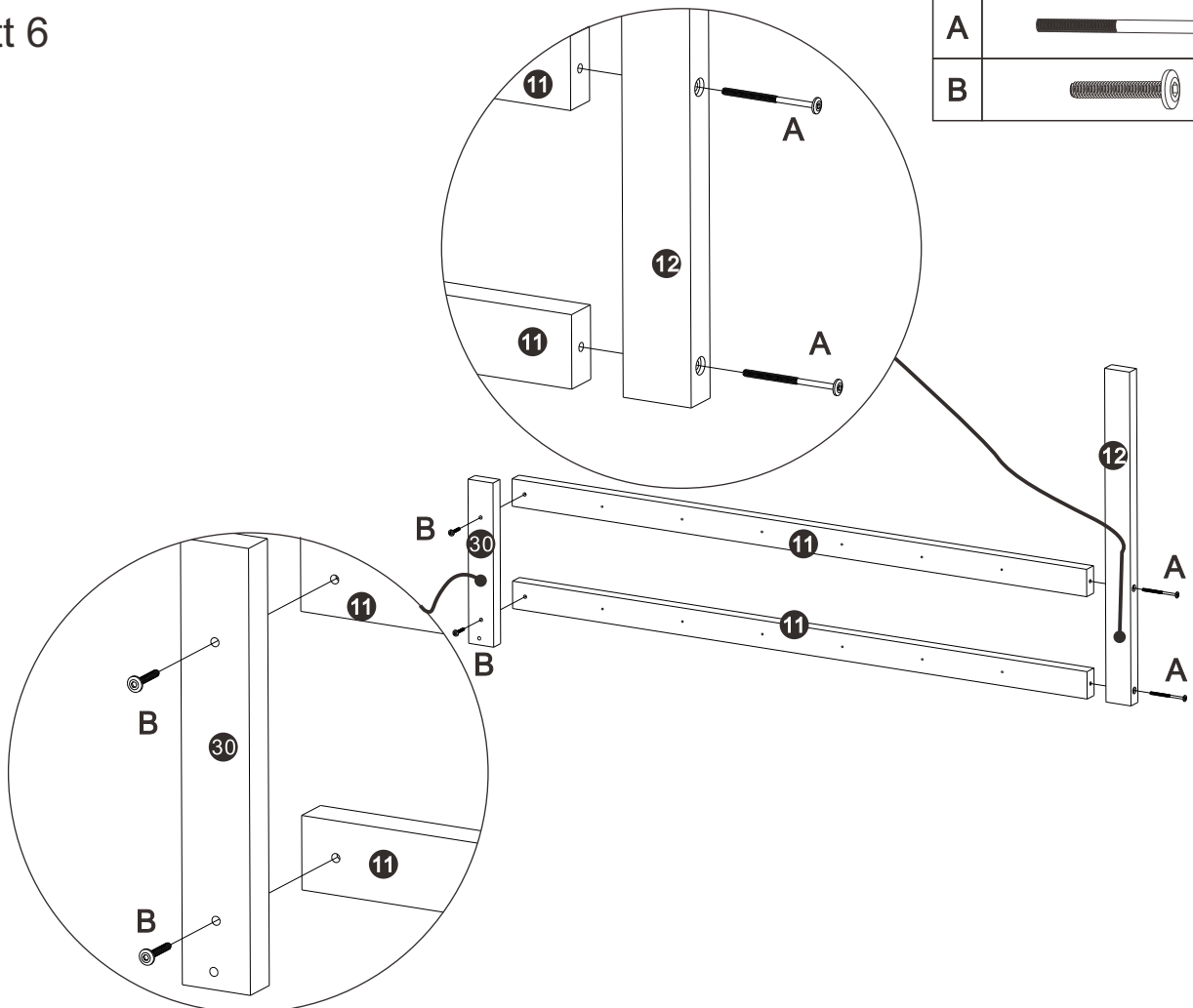

Schritt 7

E



12

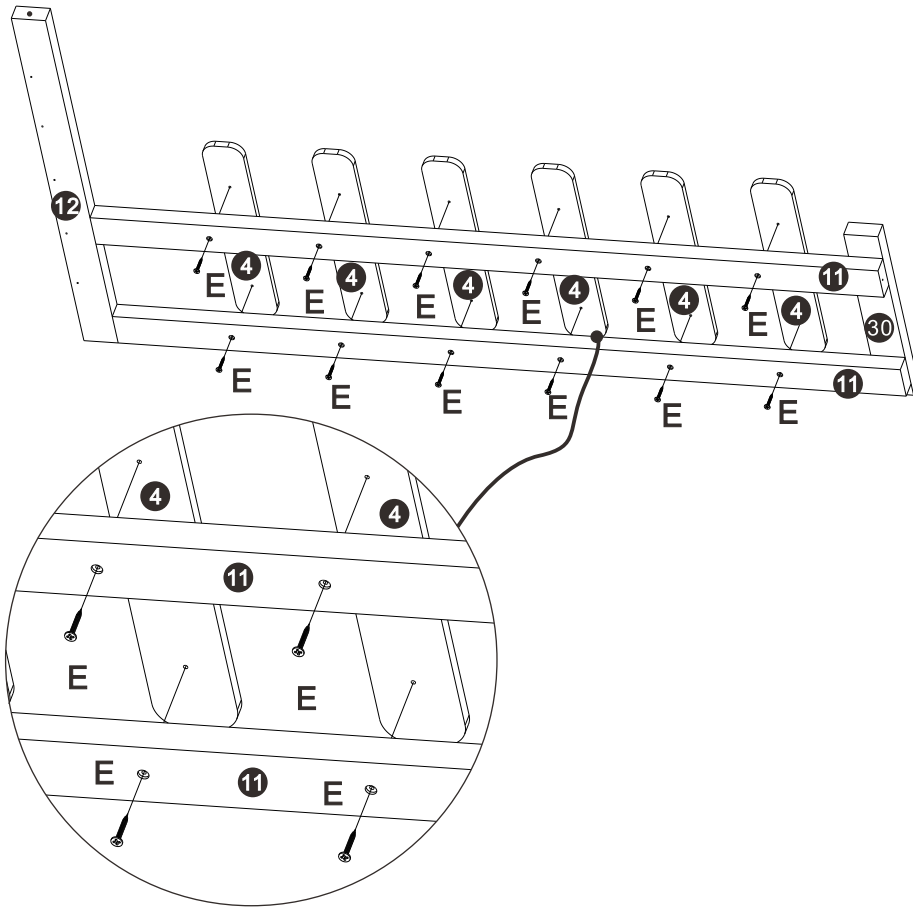

Schritt 8



F

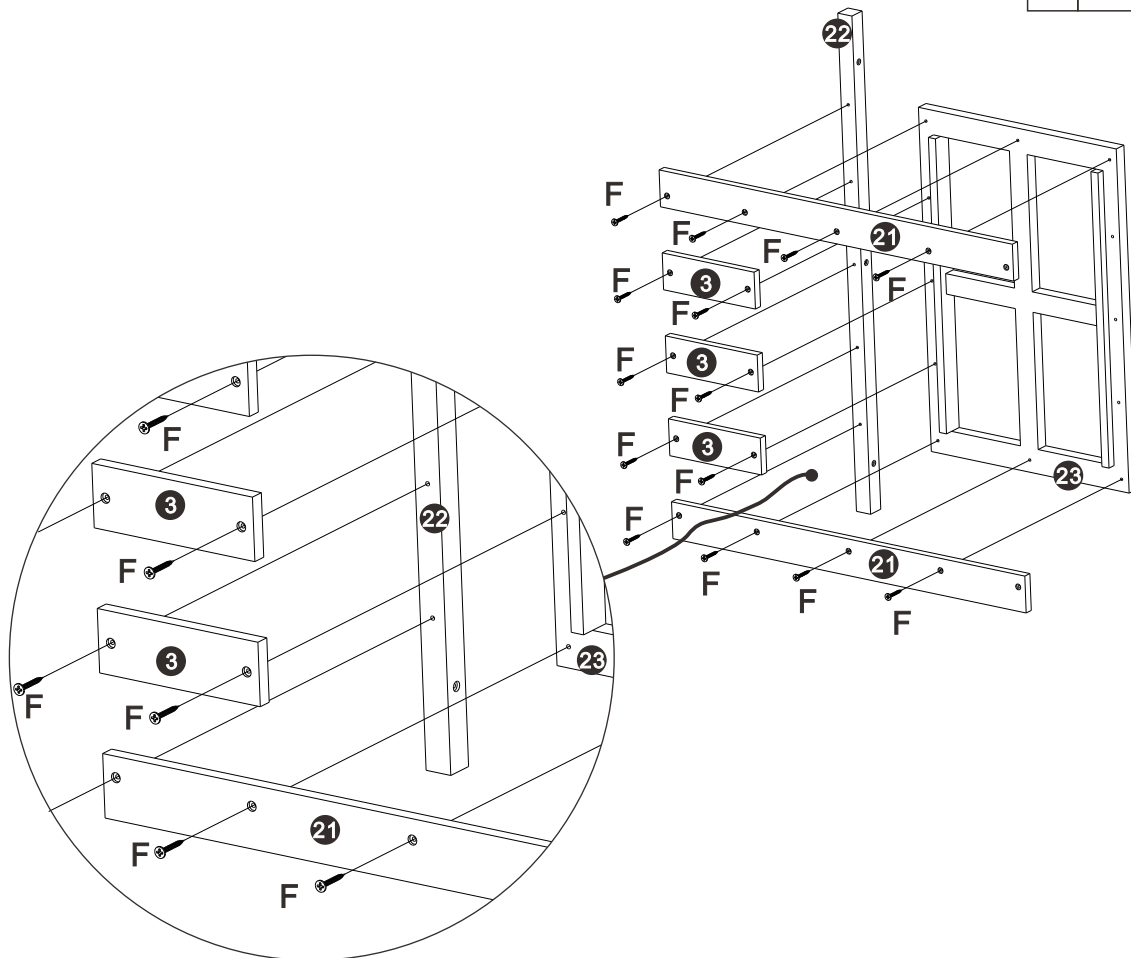

14



Schritt 9

I		6
J		3

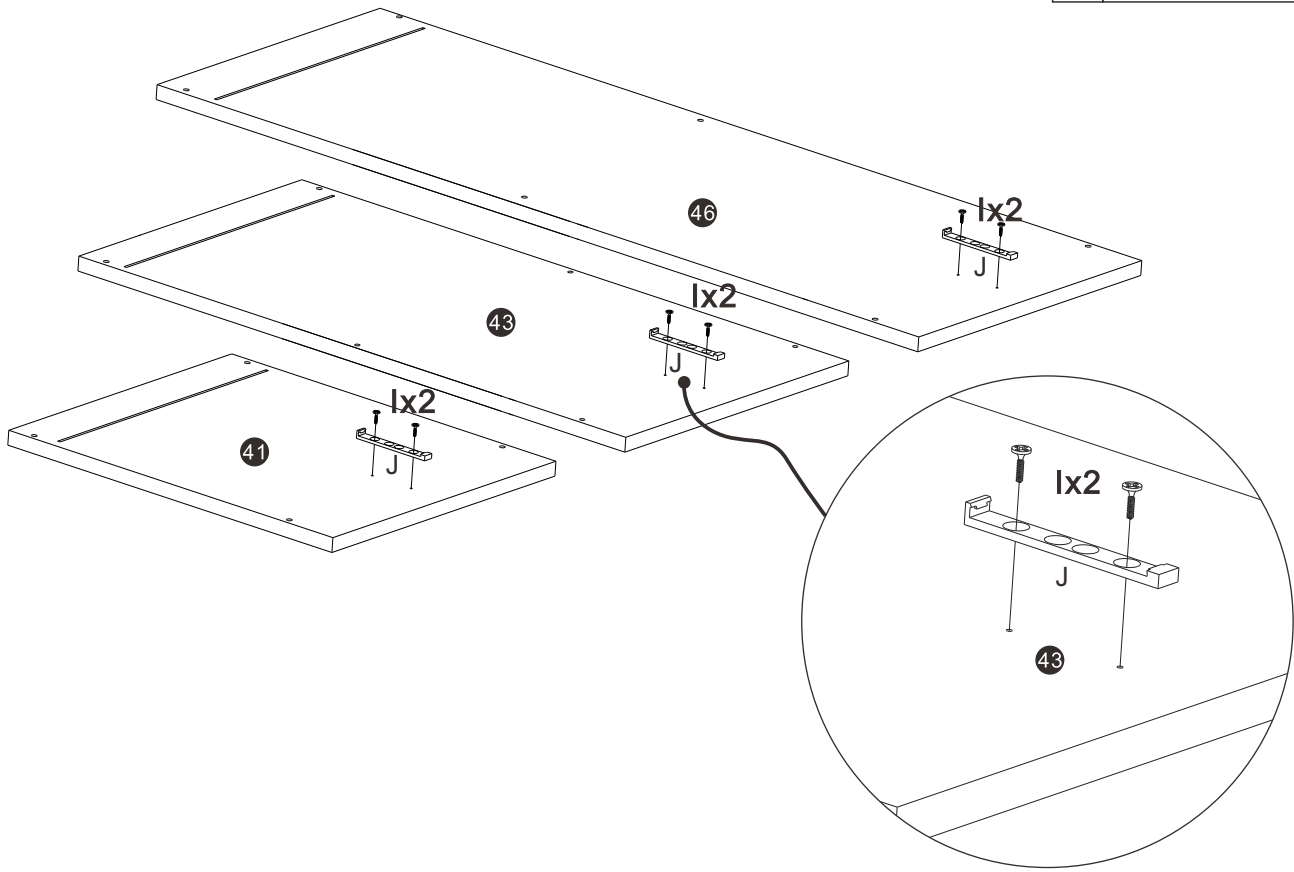

Schritt 10

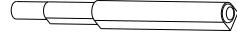
J		3
---	---	---

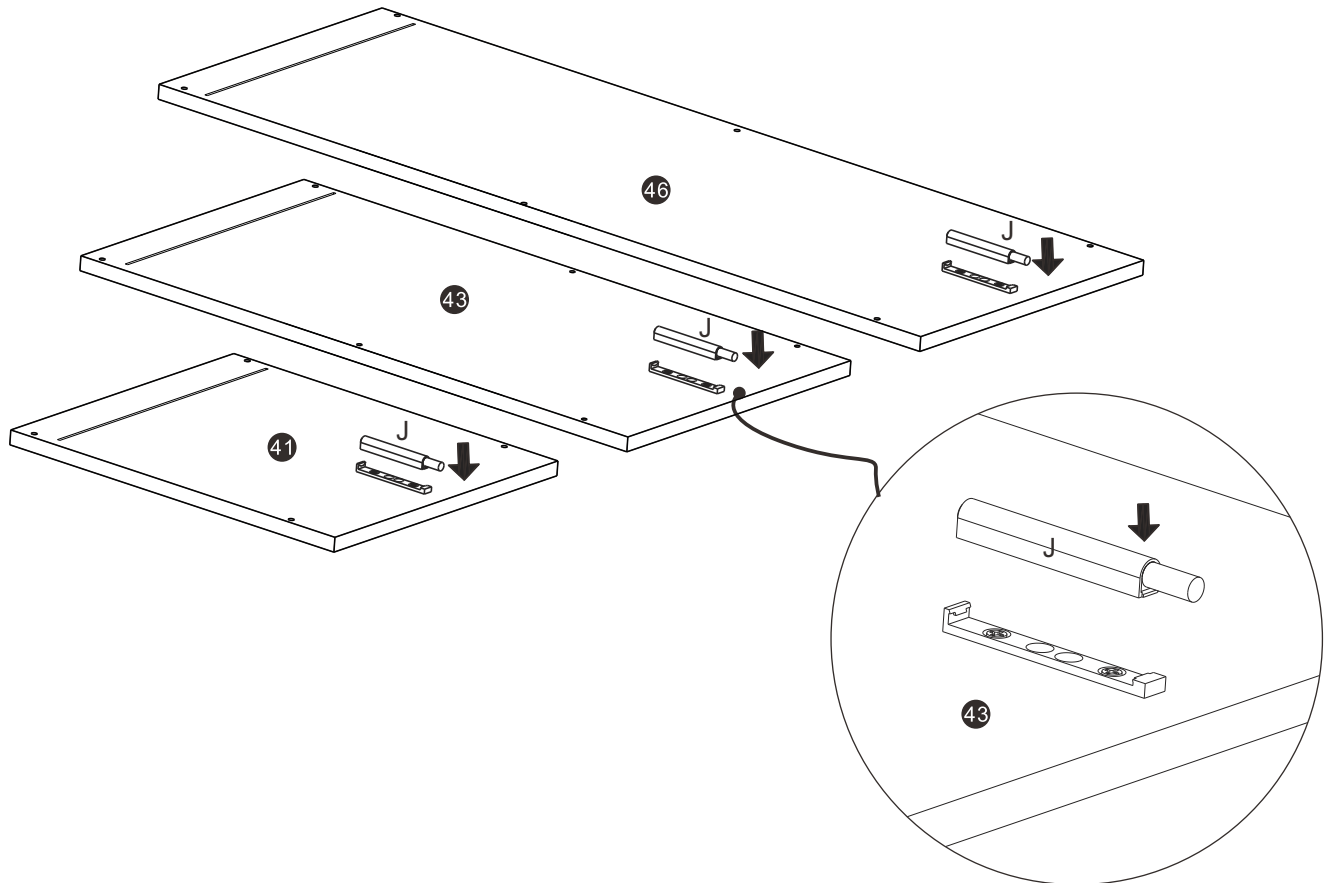

Schritt 11

K

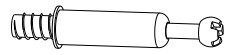

16

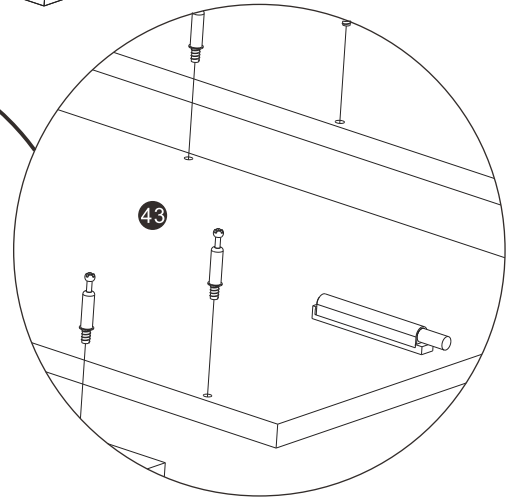
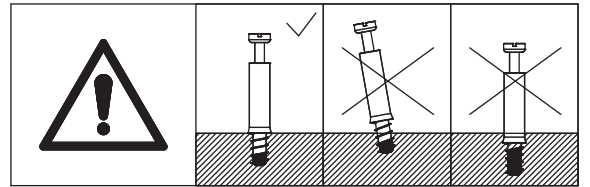
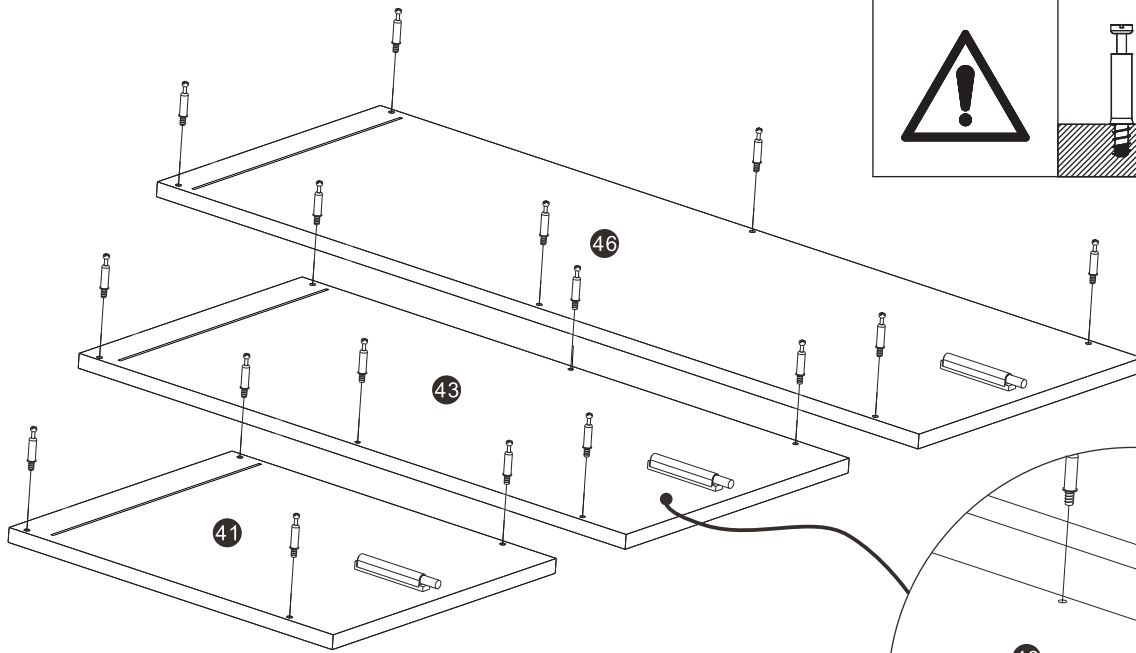

Schritt 12



K

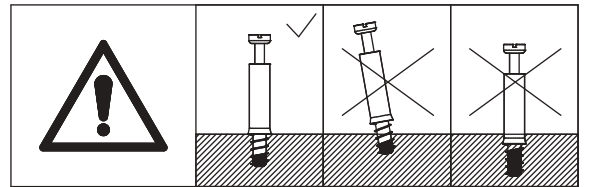
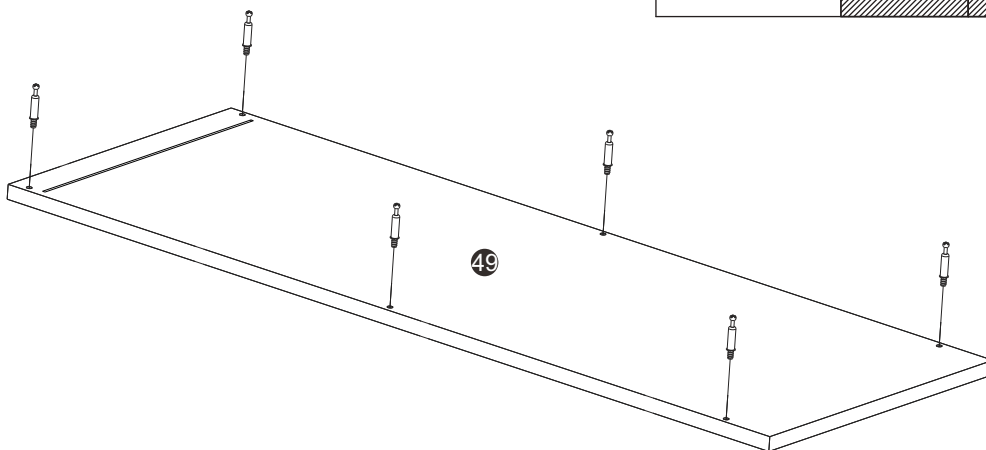

6

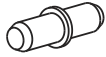

Schritt 13

M		6
J		3
I		3

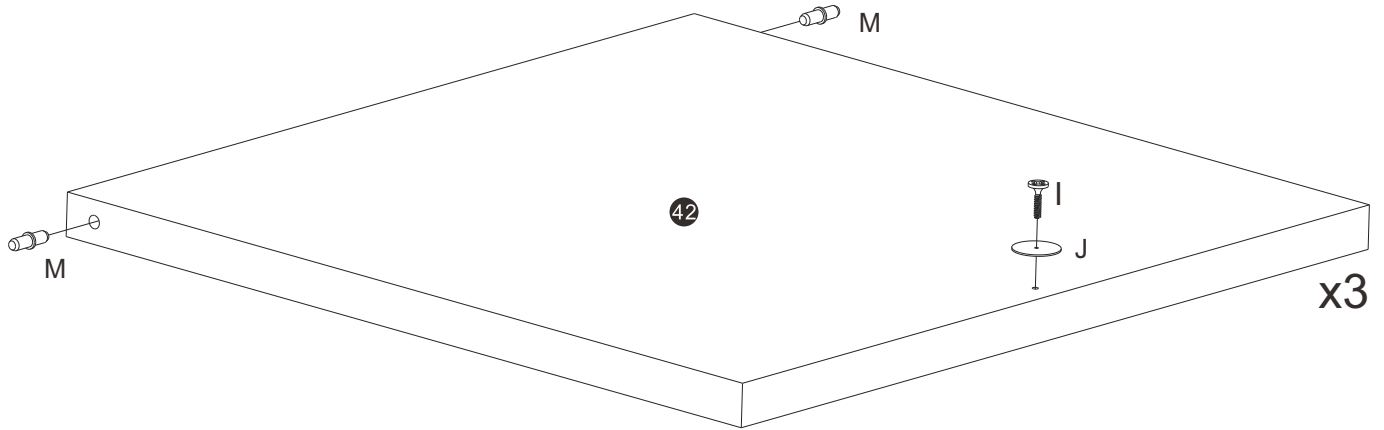

Schritt 14

L		4
---	---	---

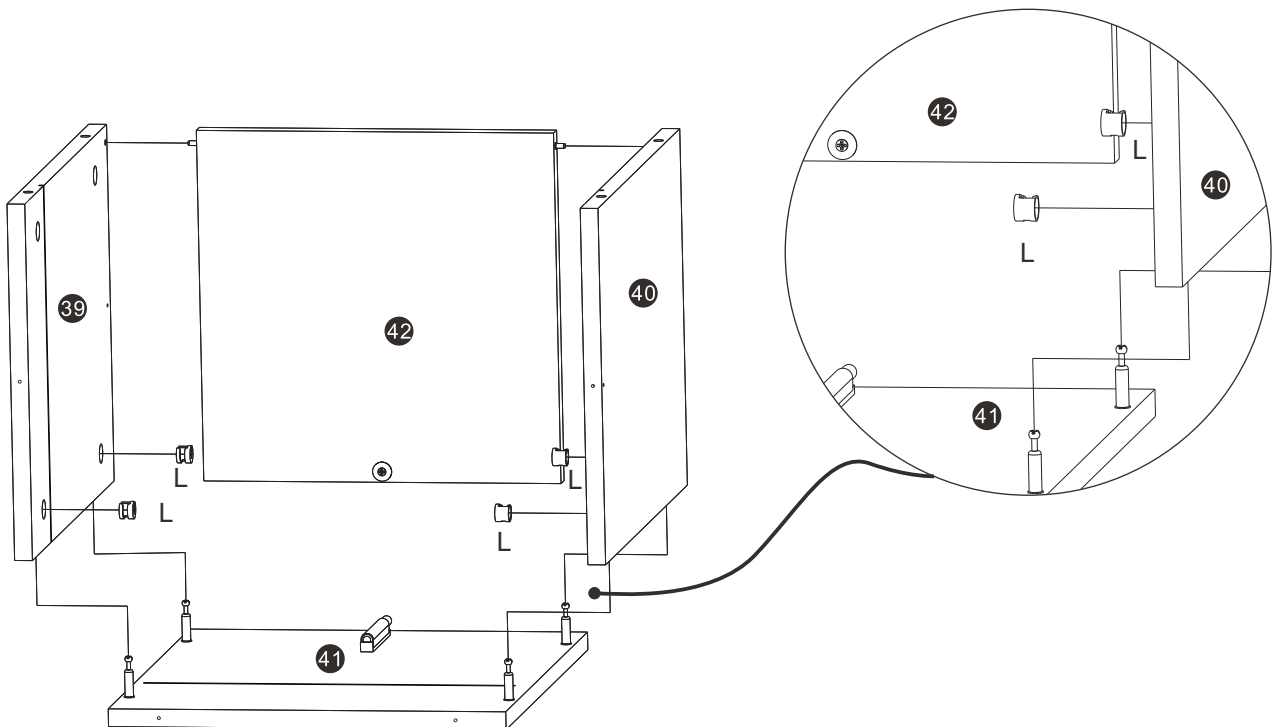
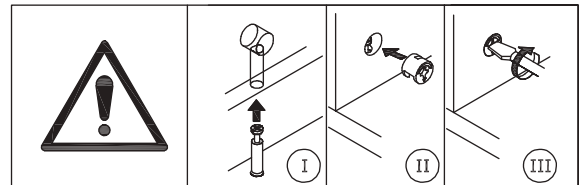

Schritt 15

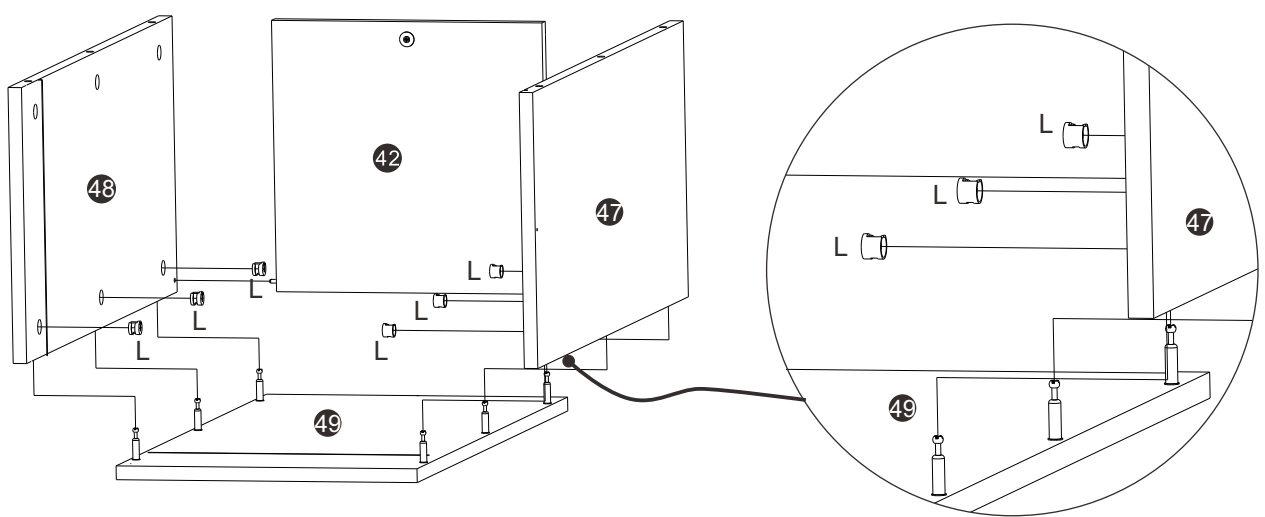
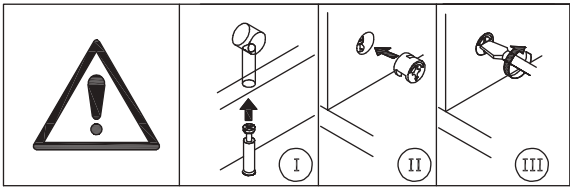

Schritt 16

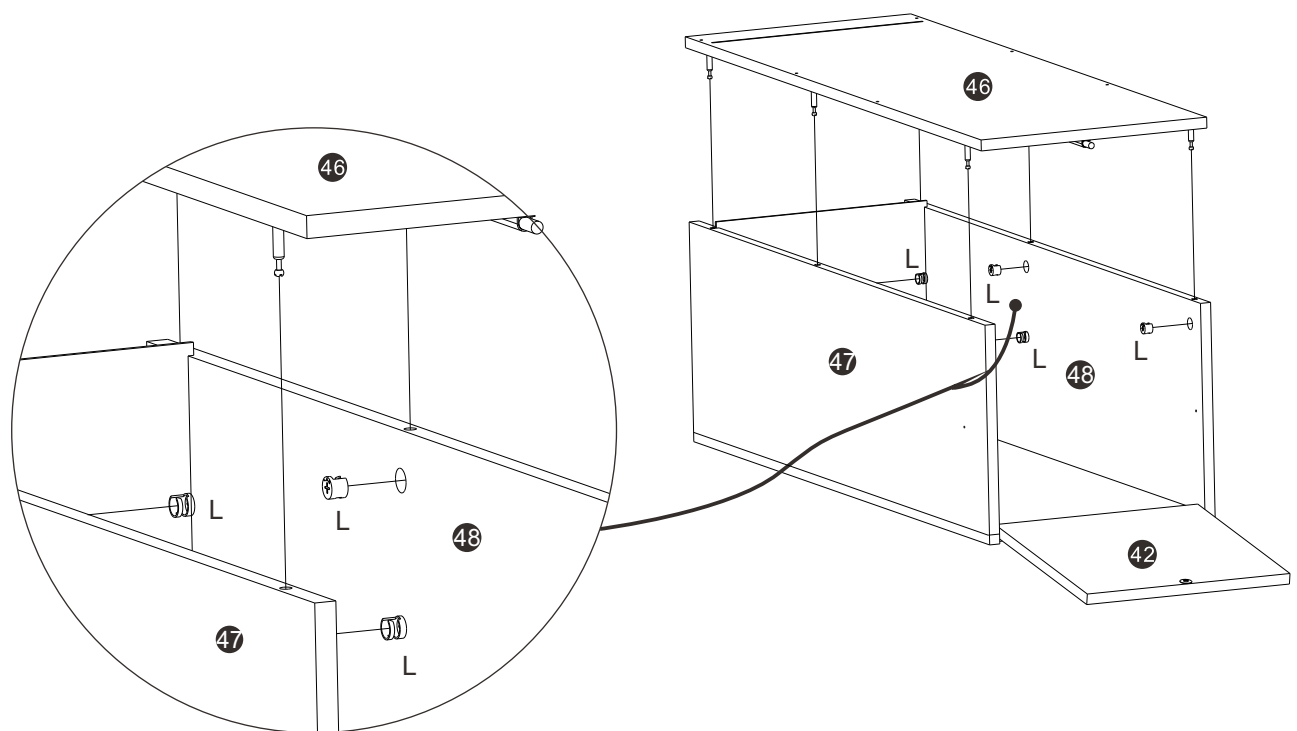
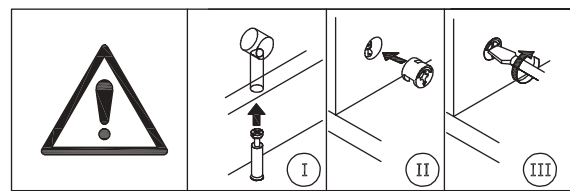

Schritt 17

L



6

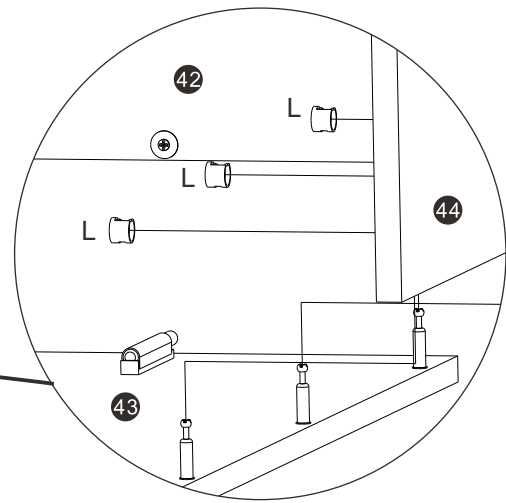
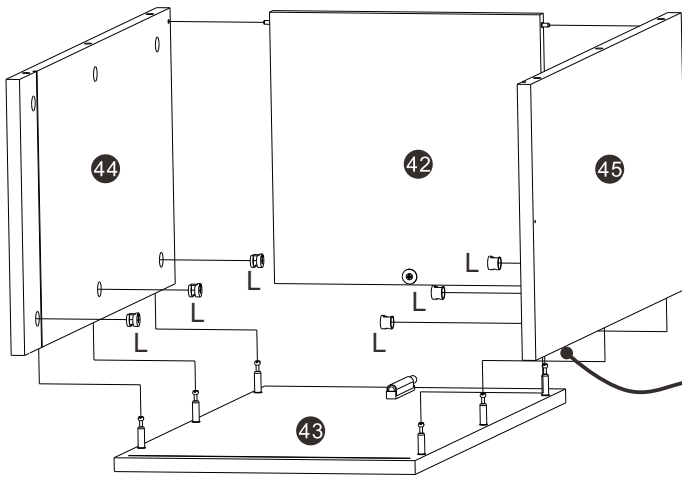
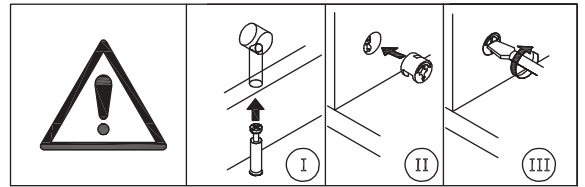

Schritt 18

K



10

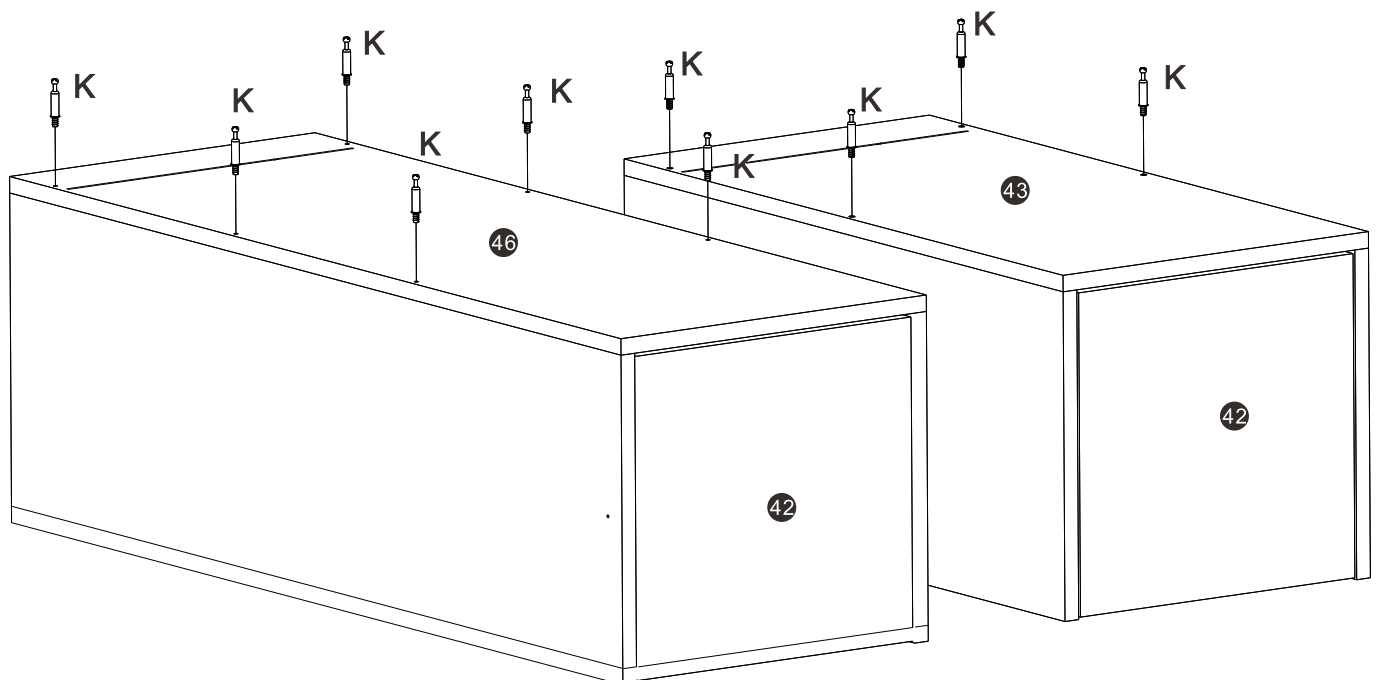
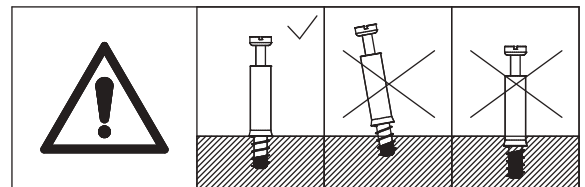

Schritt 19

L



6

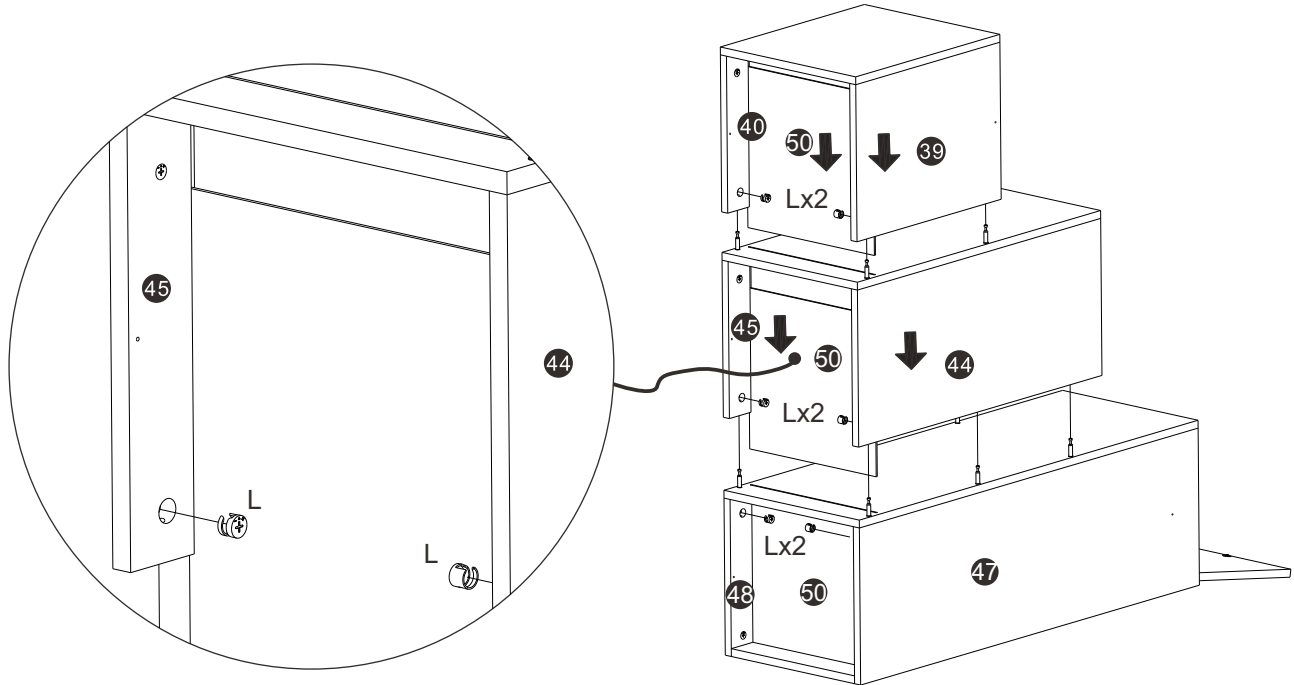
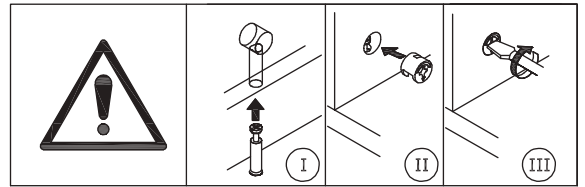

Schritt 20



L

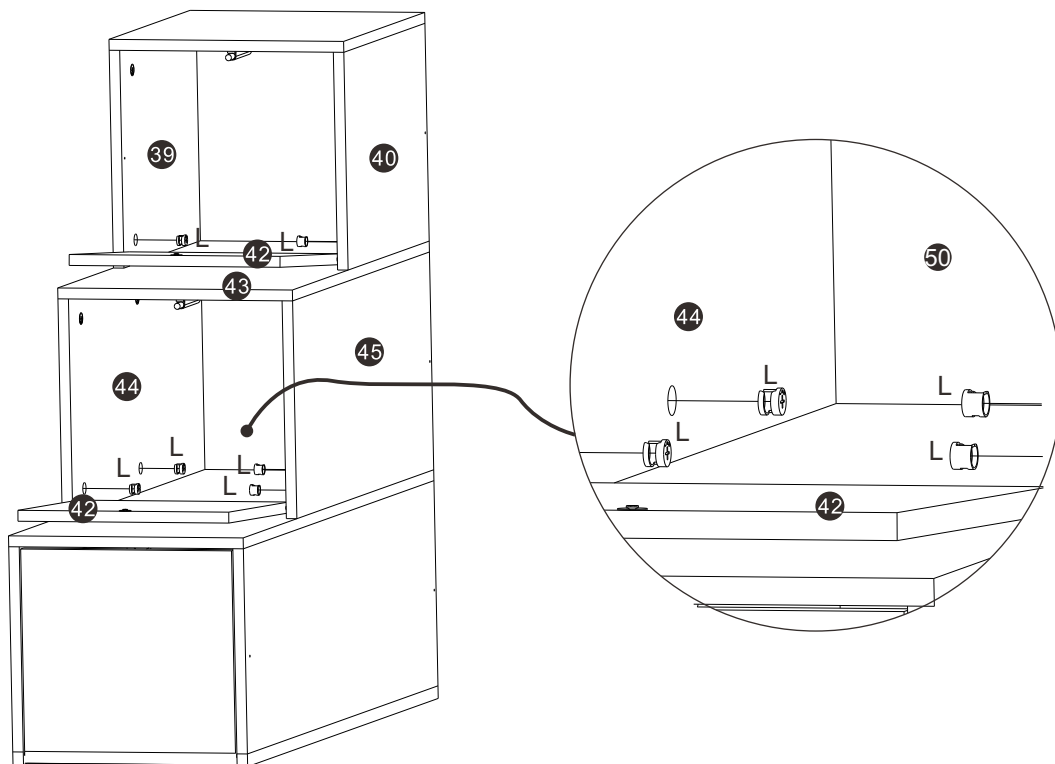
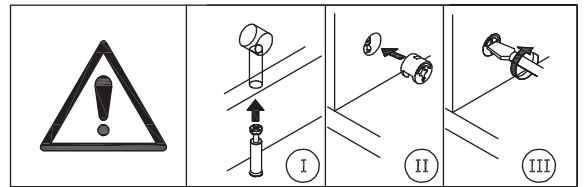

6



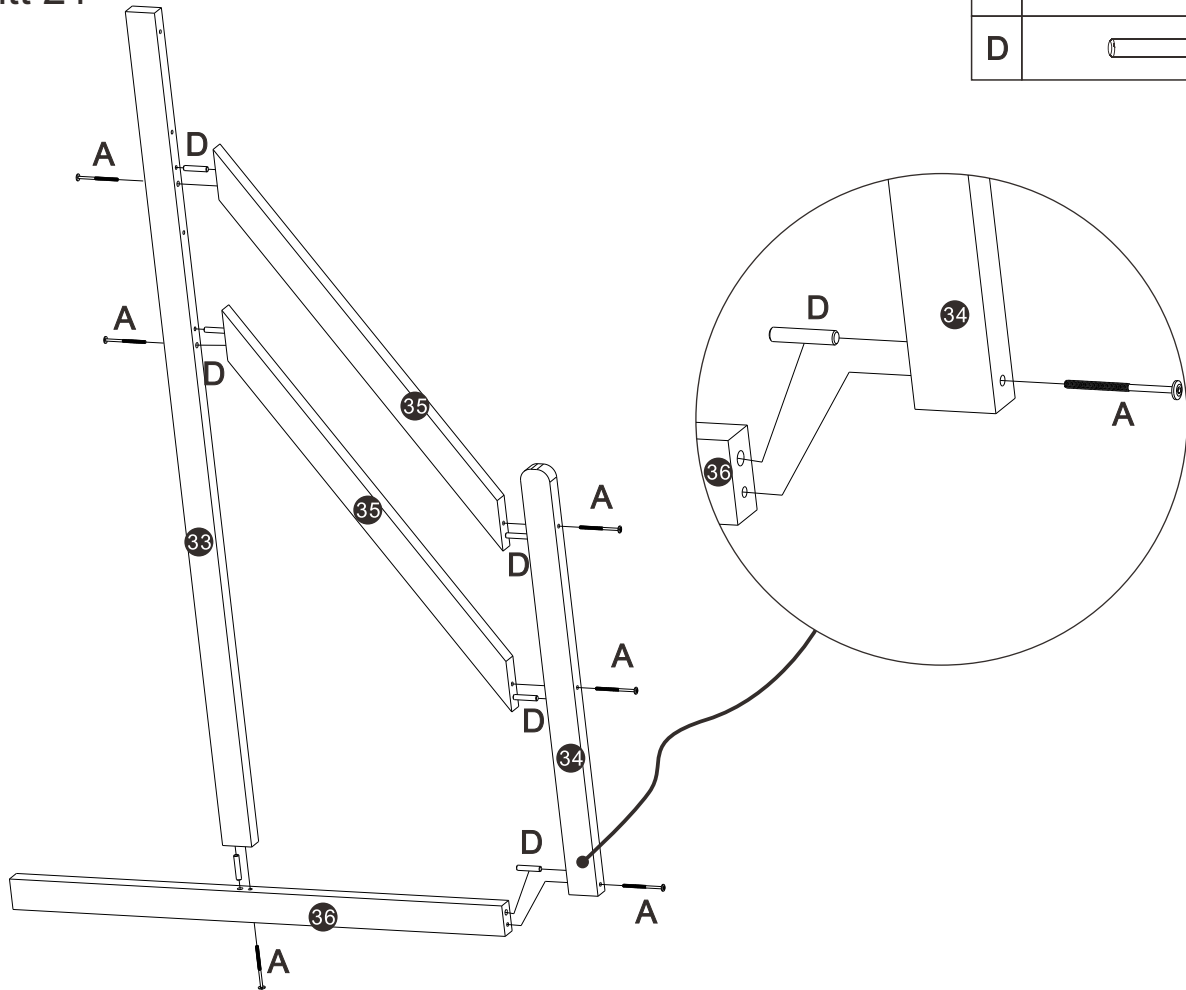

Schritt 21

A		6
D		6



Schritt 22

Installieren Sie die D-Schraube auf dem 37-Holzmaterial (nach unten), um Konflikte in nachfolgenden Einbaulöchern zu vermeiden

A		3
B		4
D		7

Install the D-type screw on the 37 # wooden material (to the bottom) to avoid conflicts in subsequent installation holes

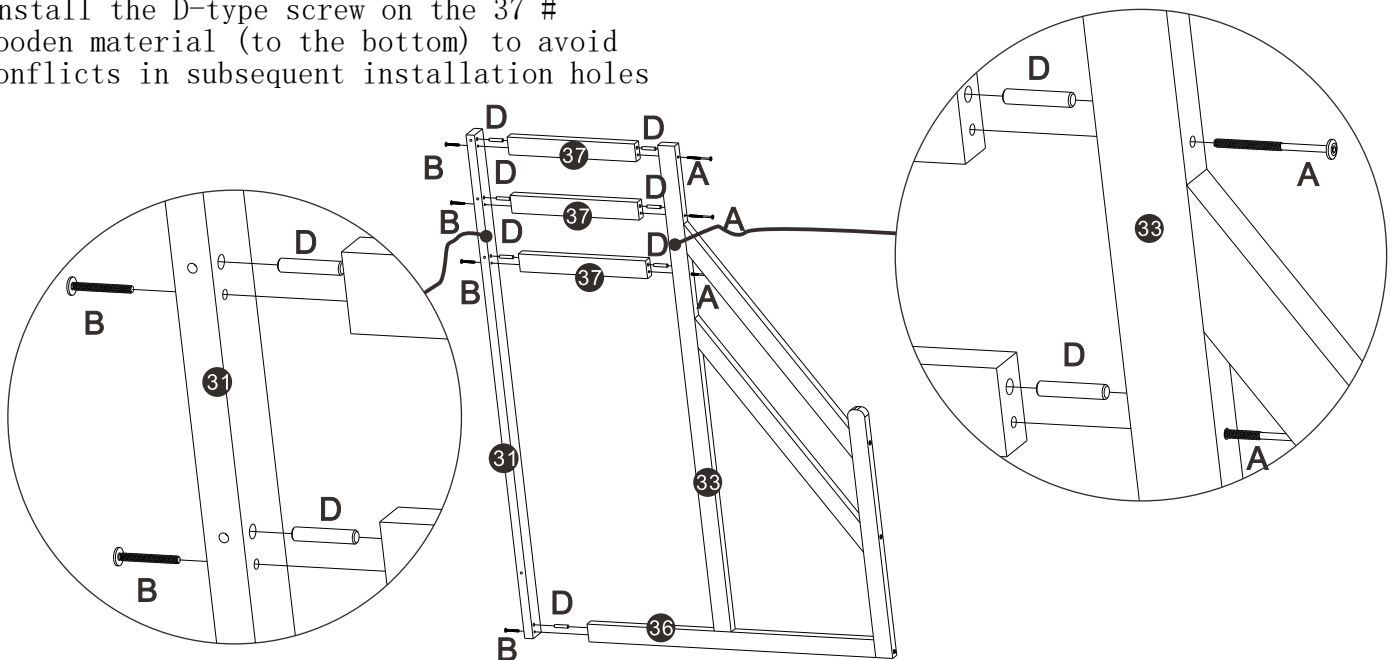

Schritt 23

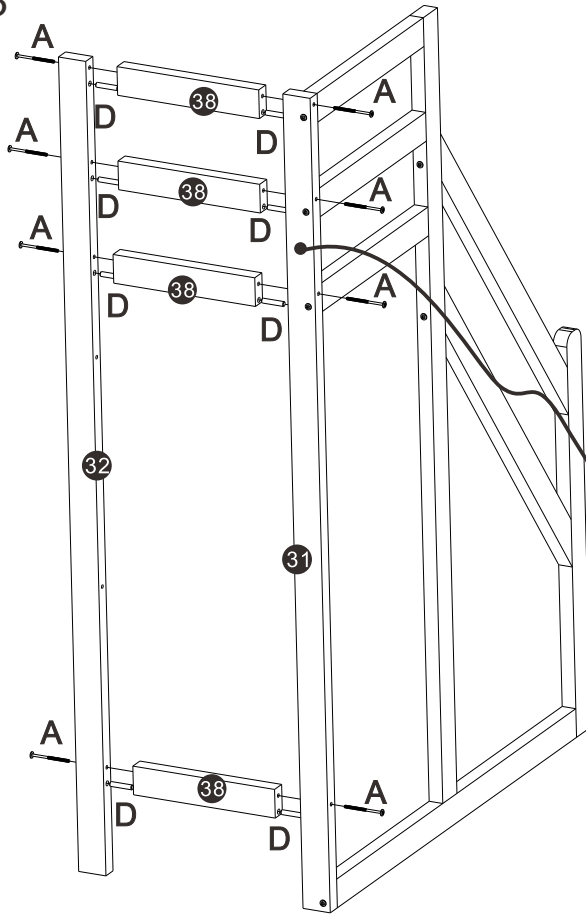

A		8
D		8

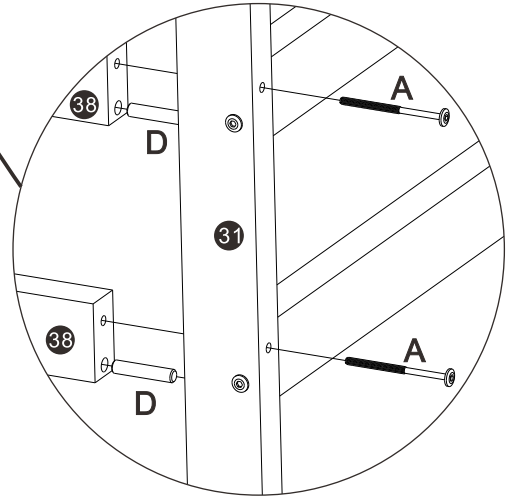

Schritt 24

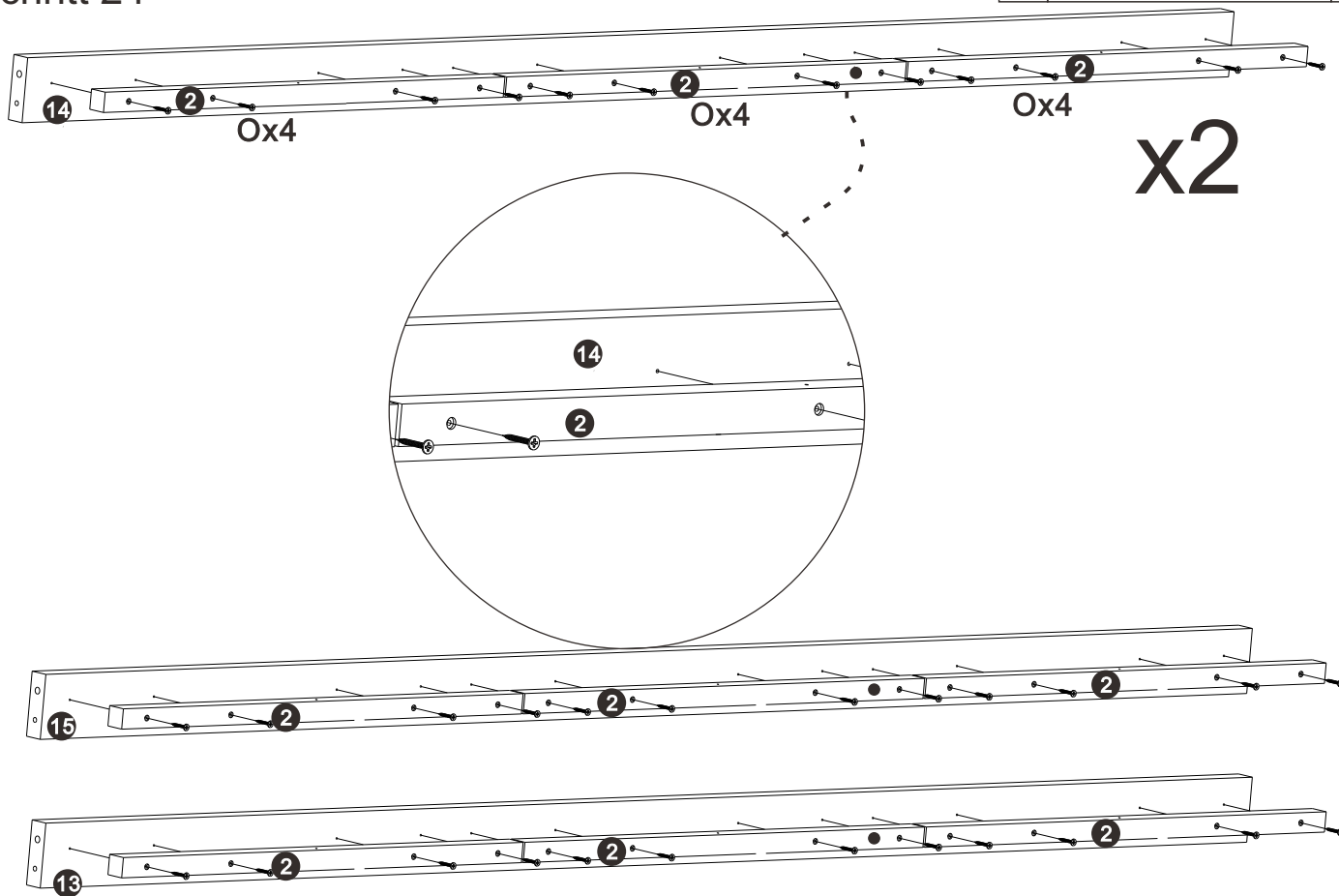

O		48
---	--	----

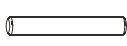

x2

Schritt 25

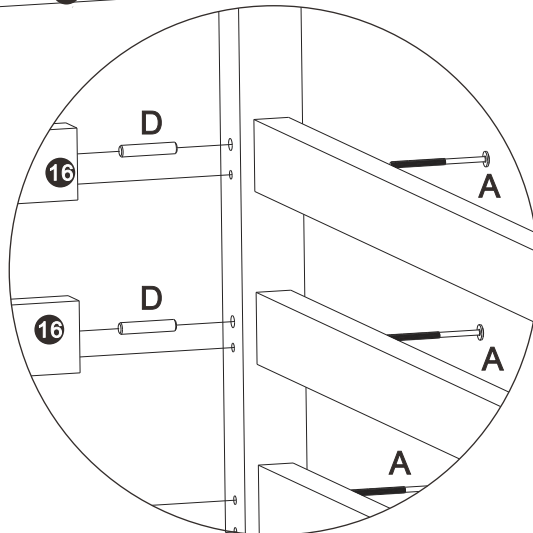
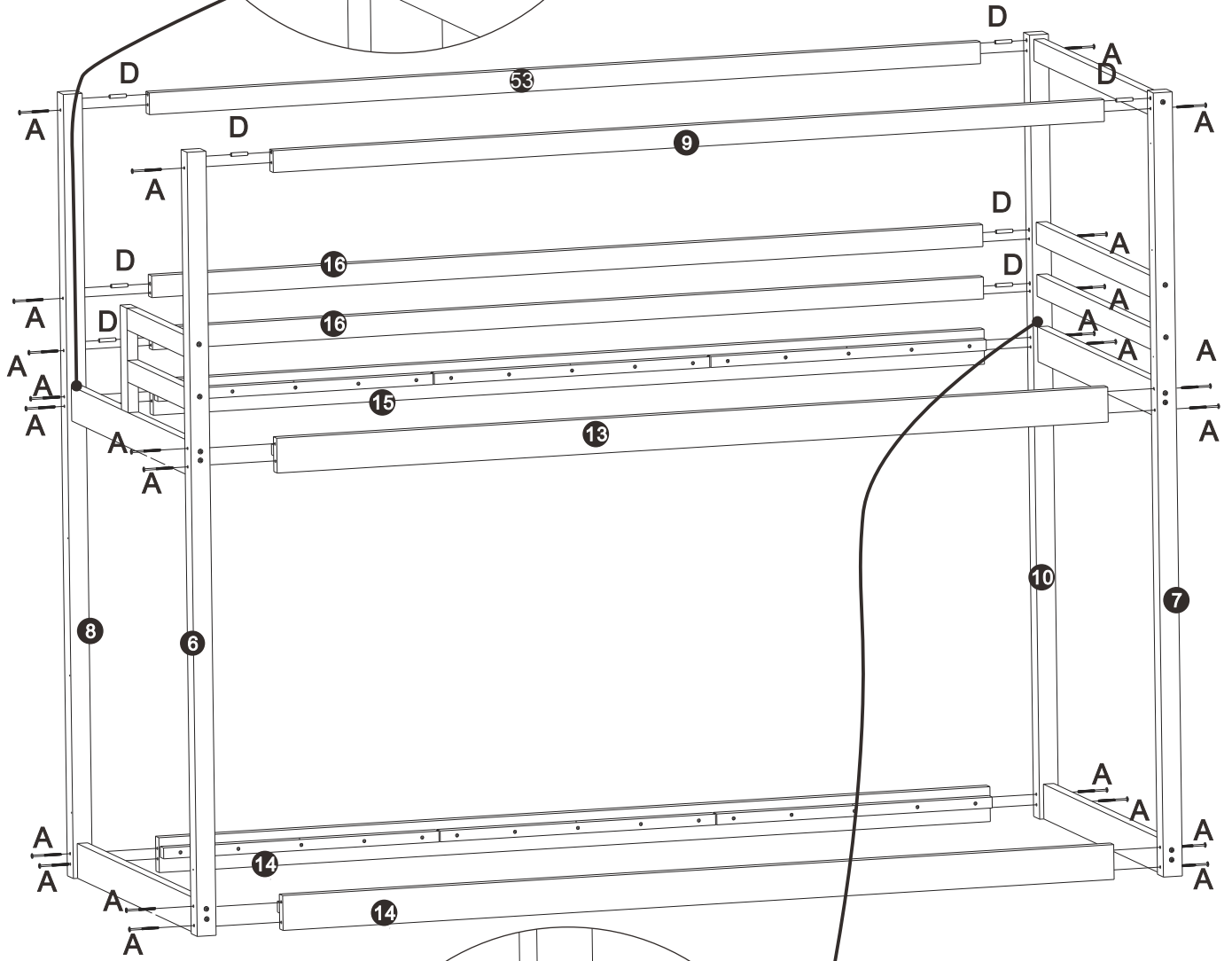
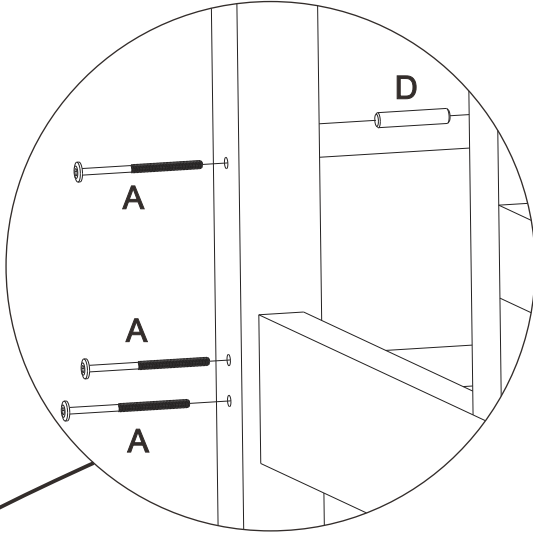
A		24
D		8



Schritt 26

A		1
B		1
R		1

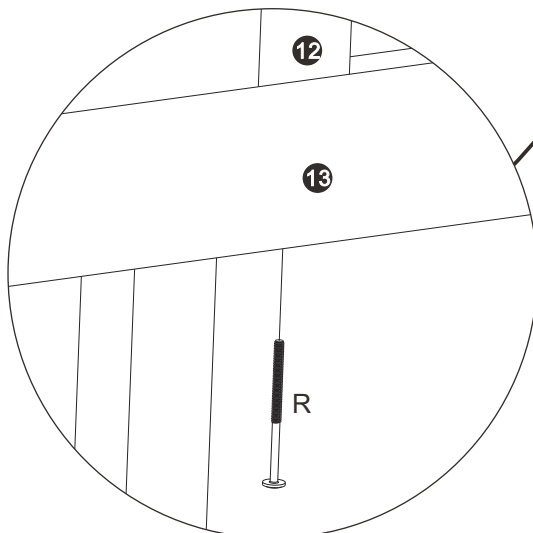
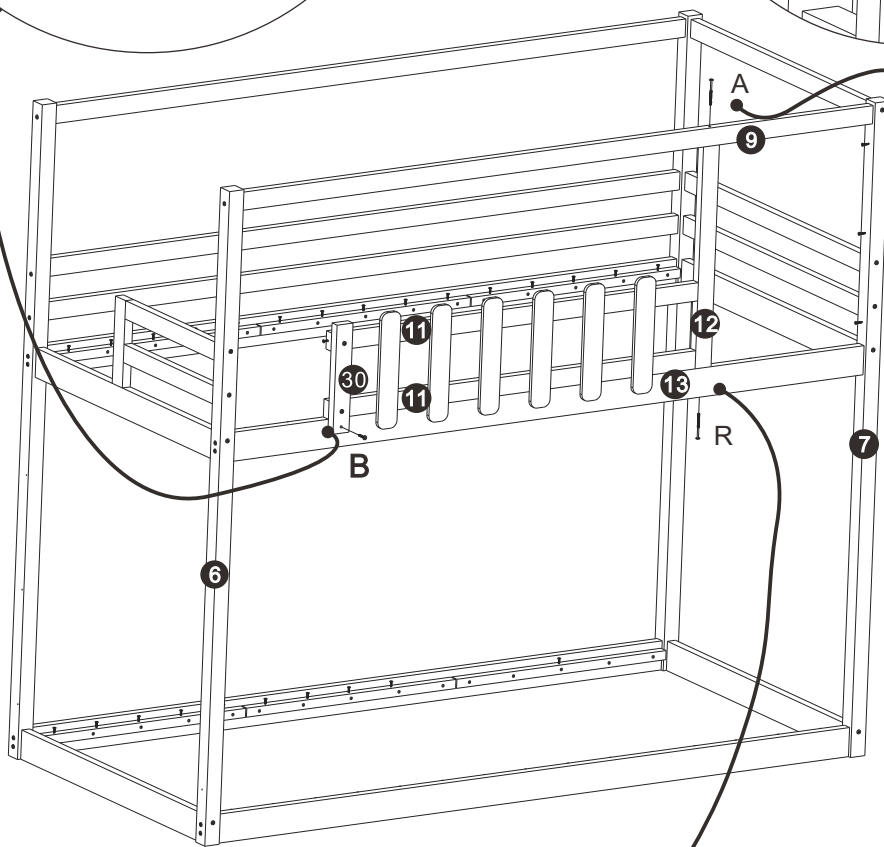
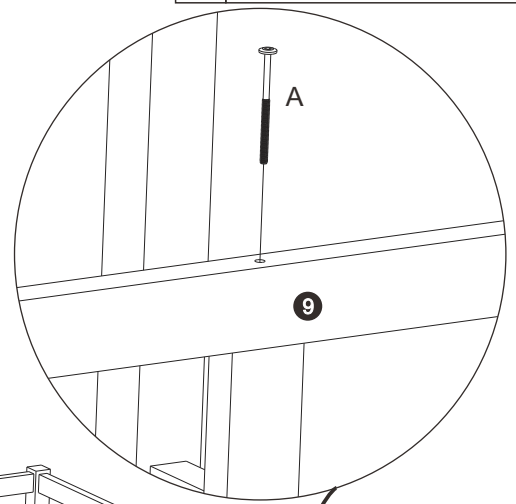
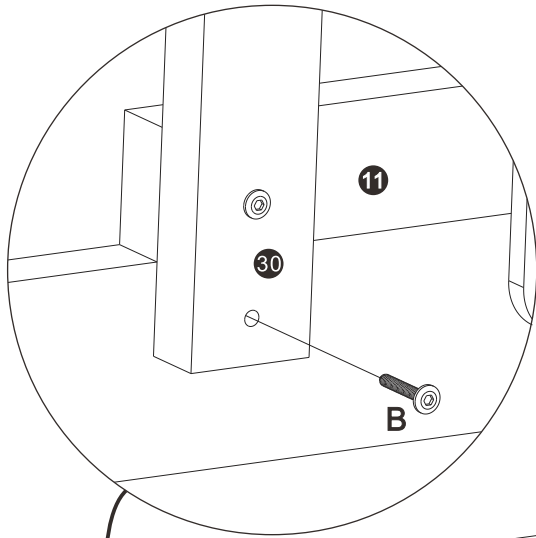

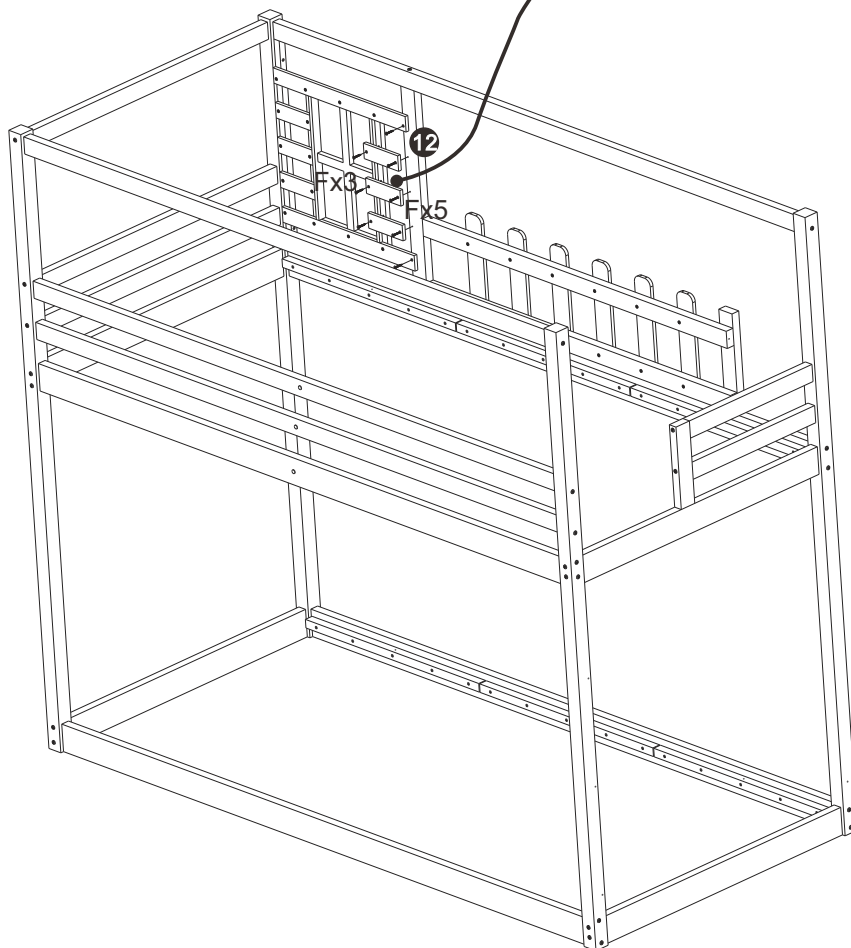
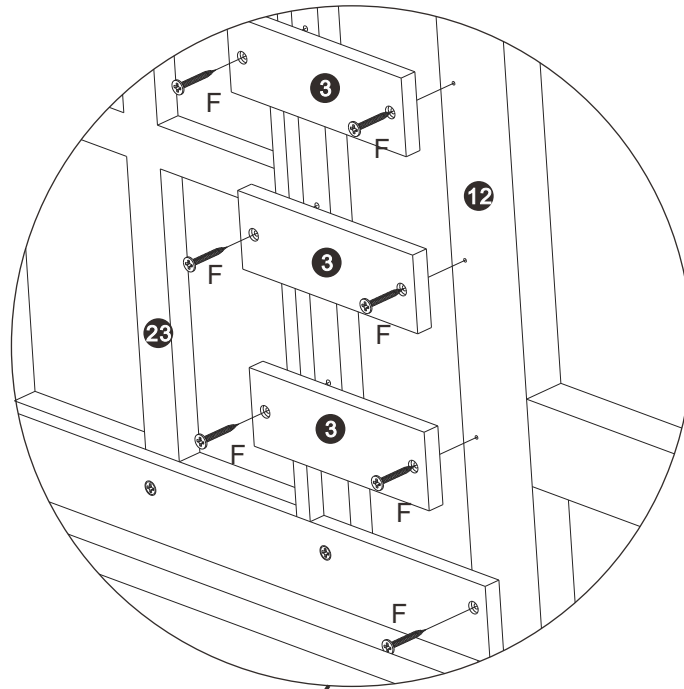

Schritt 28

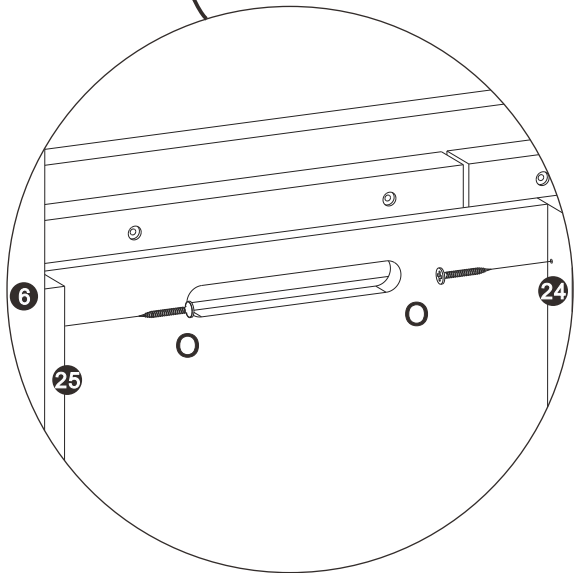
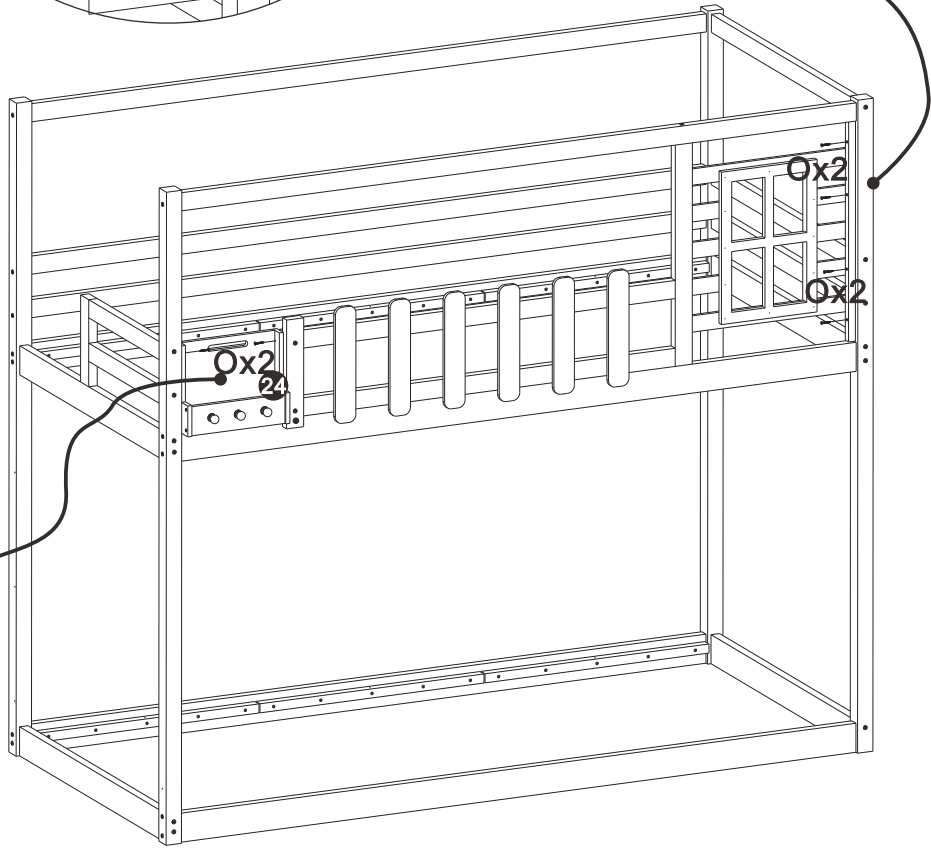
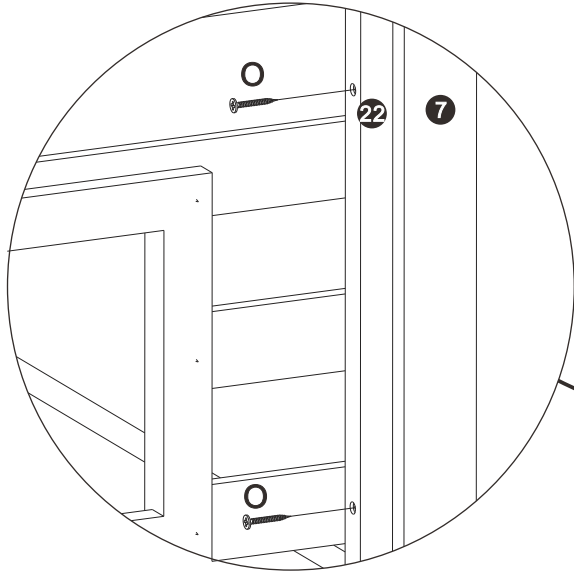

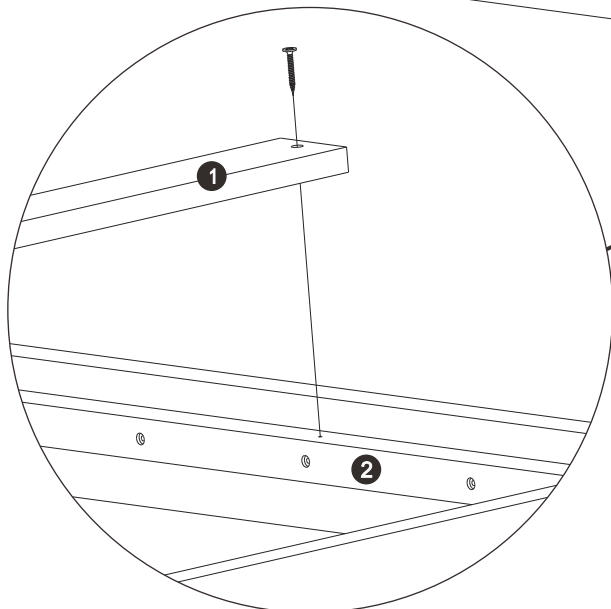
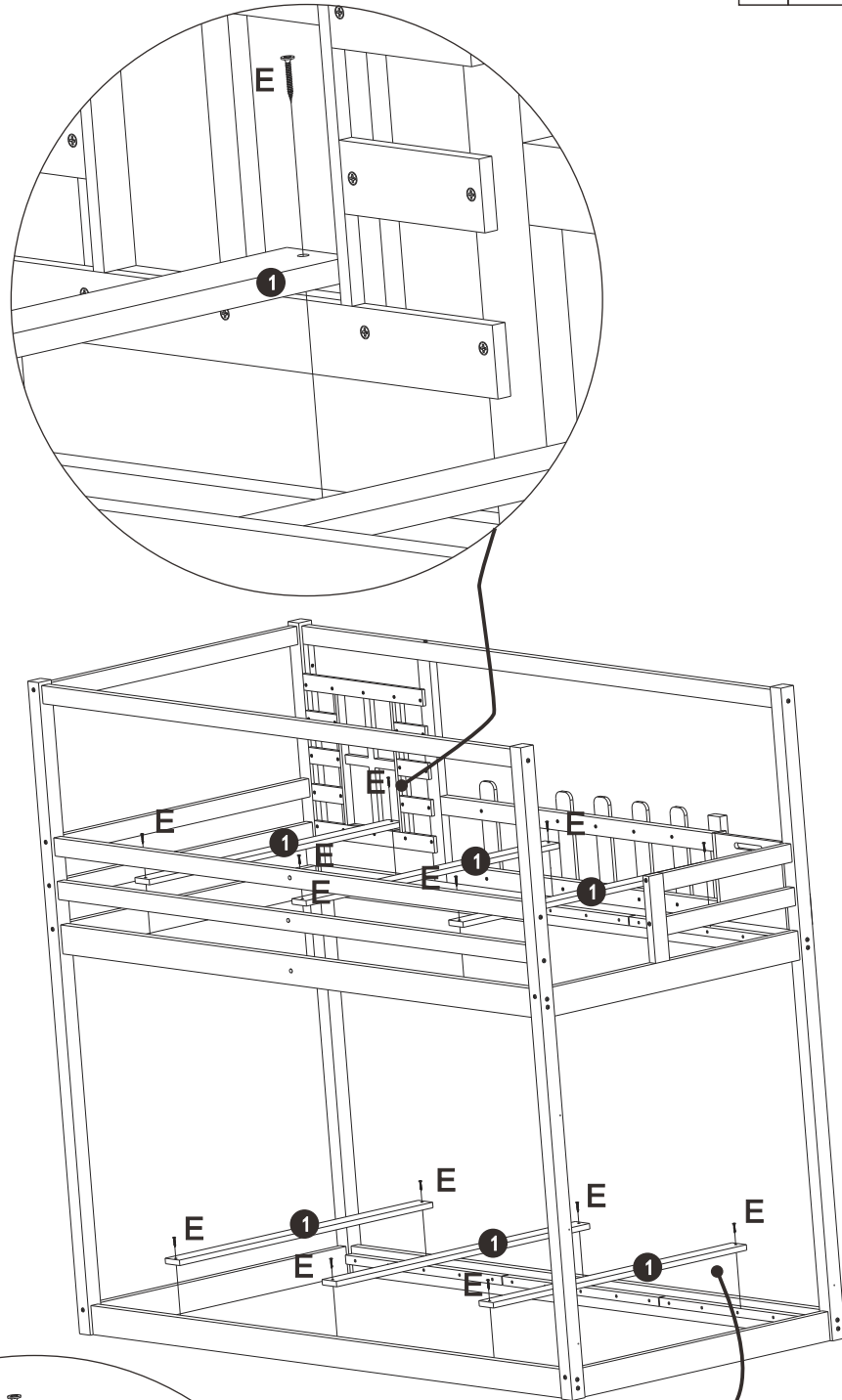

Drücken Sie bei der Montage die Bettkante fest in Richtung Mitte, um sicherzustellen, dass die Bettplatte von beiden Seiten dicht und lückenlos montiert werden kann.

When assembling, press the edge of the bed tightly towards the middle to ensure that the bed plate can be installed tightly away from both sides without gaps.

