

Montageanleitung

1 → 2 → 3 ...

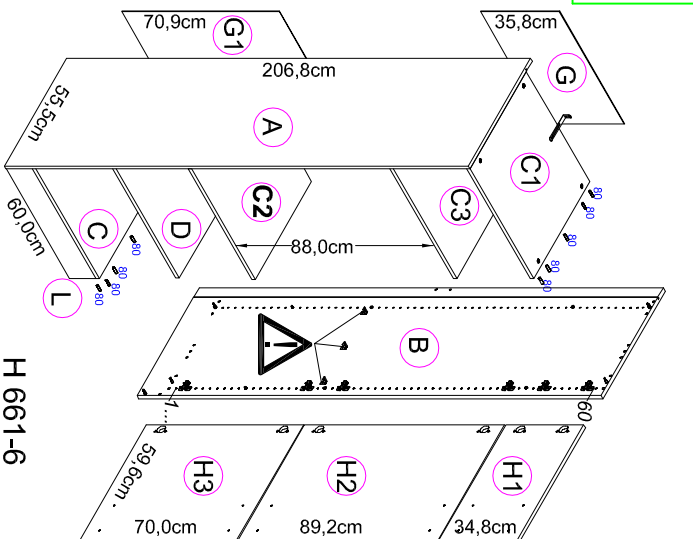

Service-Hotline
 01805-678101
 0,14€ pro Min.
++49 für Österreich
 0,14€ pro Min.
Auslandstarif pro Min.
Service@optifit.de
 vorr Nederland en België
00800-40119350
benelux@optifit.de

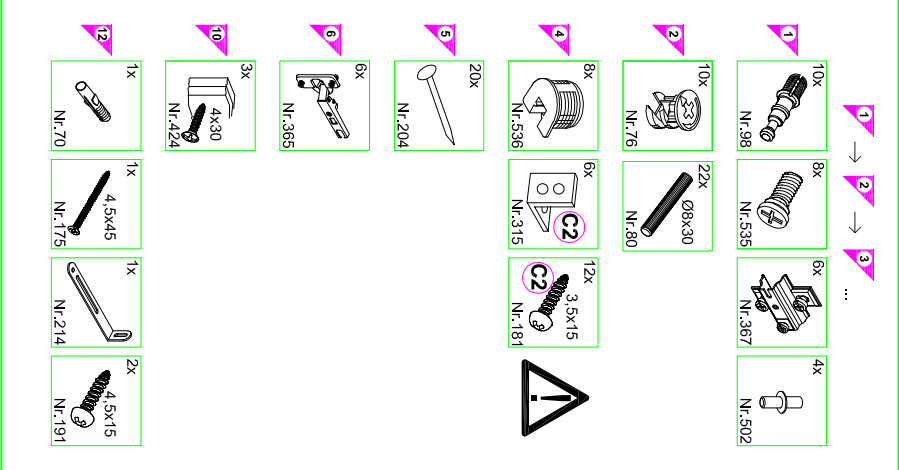
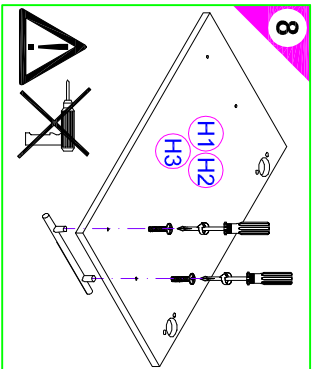
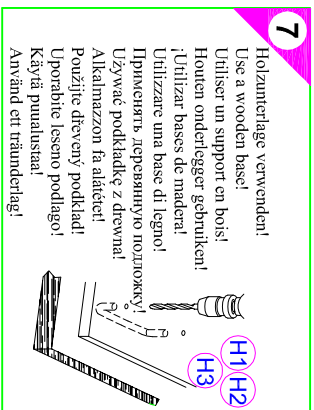
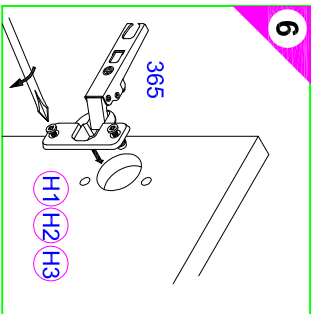
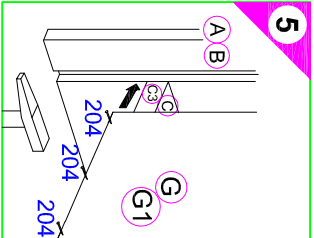
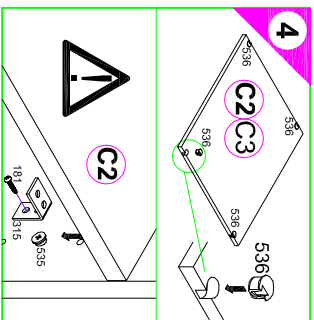
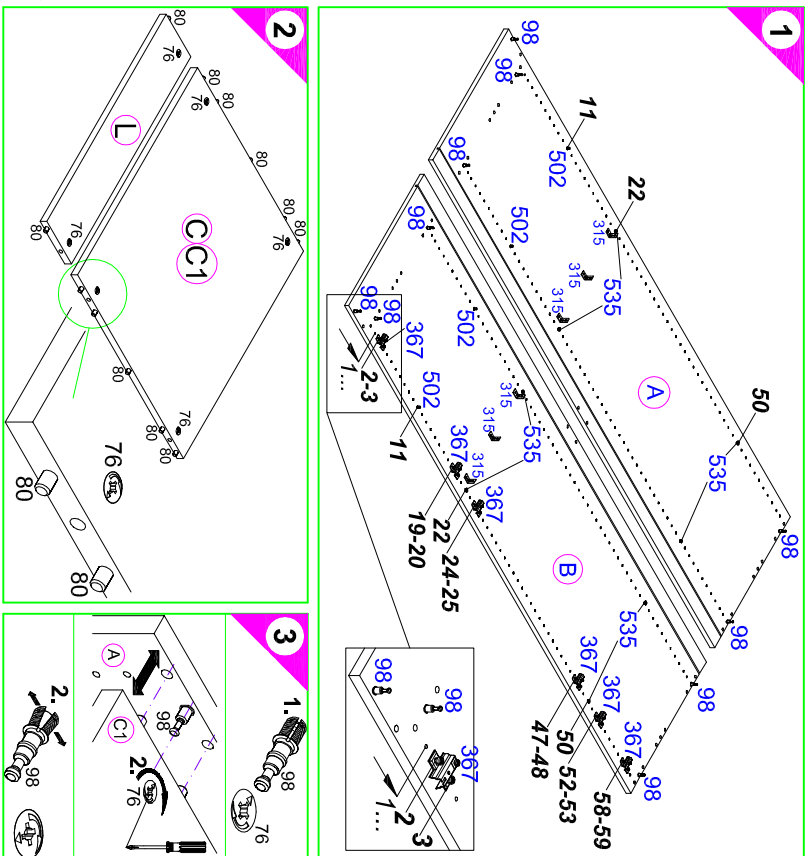
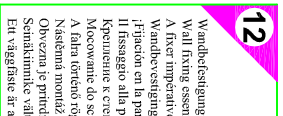
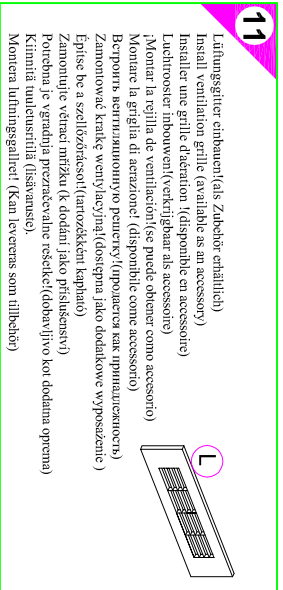
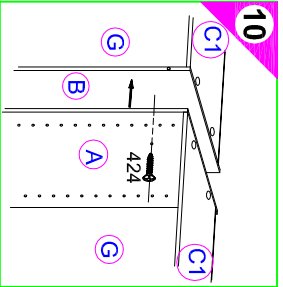
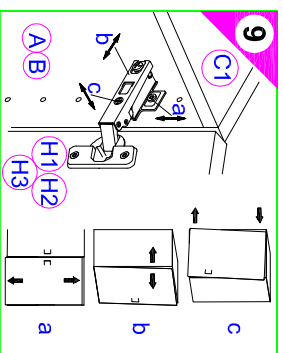
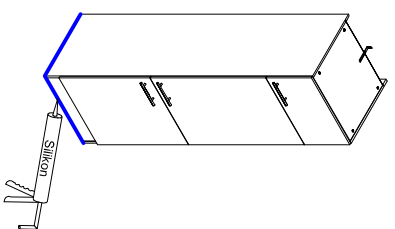

Ersatzteile/Spare parts/pièces de rechange/Reserveonderdelen/Piezas de recambio/Ricambi/Zapachne časti/Części zamienne/potálkalkatárszek/Náhradní části/Nadomestni deli/Varaosat/reservdelar

60cm H661-6
A E961011 **B** E961012 **C** E954223 **C1** E954223 **C2** E950223 **C3** E950223 **D** E950303 **E** E970090 **G1** E970109

H1 E980556 **H2** E940605 **H3** E940621 **L** E970973

L E950223 **L** E950223 **L** E950223 **L** E950223 **L** E950223 **L** E950223 **L** E950223 **L** E950223

500584.2 B 08/12 st

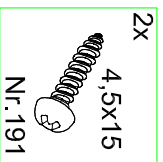
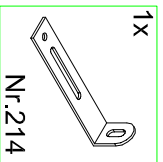
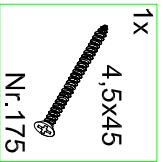
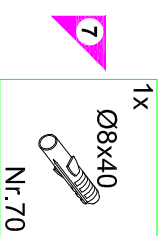
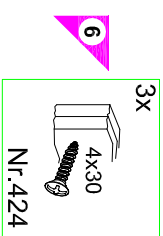
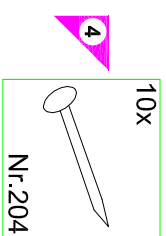
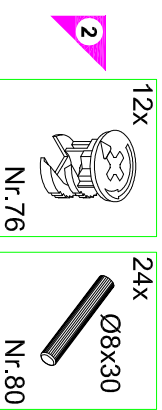
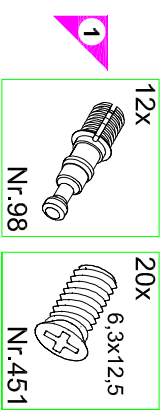
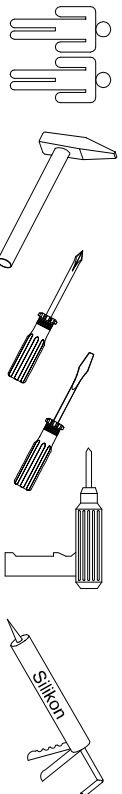
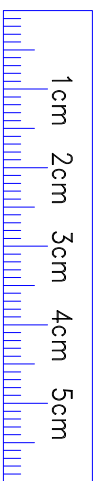

Service-Hotline
01805-678101
0,14€ pro Minute
++49 für Österreich
Auslandstarif pro Minute
service@optifit.de
voor Nederland en België
00800-40119350
benelux@optifit.de

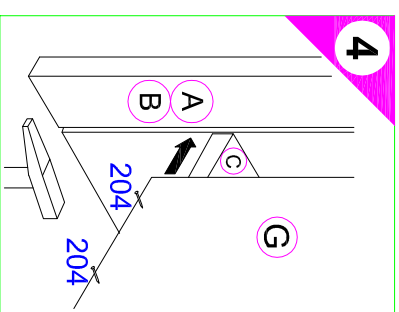

5

Holzunterlage verwenden!
Use a wooden base!
Utiliser un support en bois!
Houten onderlegger gebruiken!
! Utilizar bases de madera!
Utilizzare una base di legno!
Применять деревянную подложку!
Узывать роққадлақе з древна!
Alkalmazzon fa alátételt!
Použíte drevený roққadlaď!
U porađie leseno roққadlađo!
Käytä puualustaa!
Använd ett träunderlag!

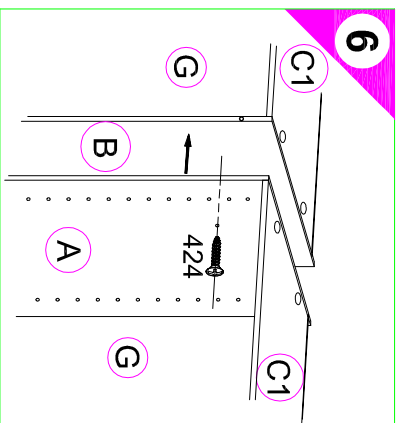
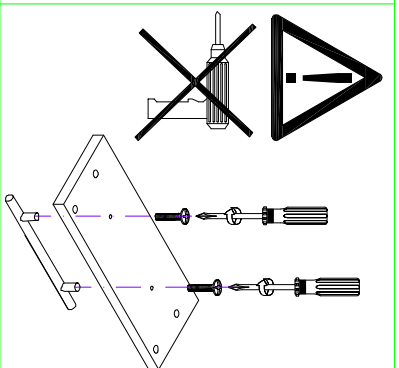
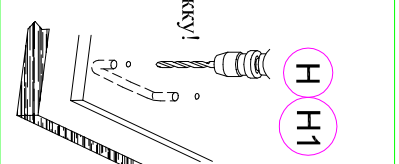

7

Wandbefestigung zwingend erforderlich!
Wall fixing essential!
A fixer impérativement au mur!
Wandbevestiging dringend vereist!
Fijacón en la pared absolutamente necesaria!
Fissaggio alla parete è indispensabile!
Kрепление к стене обязательно!
Kрепление до стіны беззастгднне konieczne!
A falra kötelező rögzítésre feltétlenül szükseg van!
Náestná montáž nezbytné nutná!
Obvezna je pritrditev na steno!
Señalkimlike vältimatón!
Ett väggfäste är absolut nödvändigt!

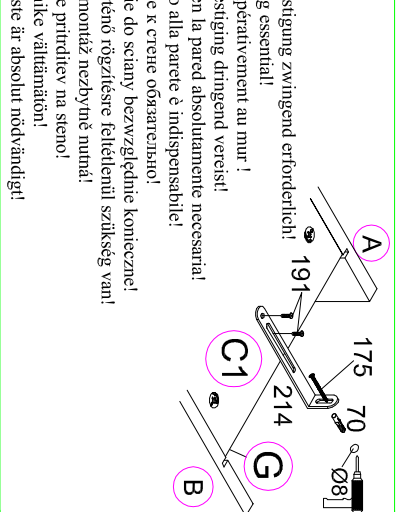

Untergrund und Befestigungsmittel auf Eignung prüfen!
Check substrate and fixings for suitability!
Controler si le support et les moyens de fixation sont bien adéquats!
Ondergrond en bevestigingsmaterial op functionaliteit controleren!
! Comprobar el suelo y los medios de fijación en cuanto a su aptitud!
! Controllare l'idoneità del fondo e del materiale di fissaggio!
! Онованне и крепельный материал проверить на пригодность!
! Podložje oraz materialy do zamocowania sprawdzić na ich przydatność!
! Az alátétletelt és a rögzítő anyagekat megjelölésű szempontból ellenőrizni kell!
! Prežkusitejše podklad a vhodnost upravljavacih prostredk!
! Preverite, če se učenajo spodnja stran in pritrdilna sredstva!
! Tarkista alustan ja kiinnittimen sopuvuus.
! Kontrollera att underlaget och fästmedlen är lämpliga!

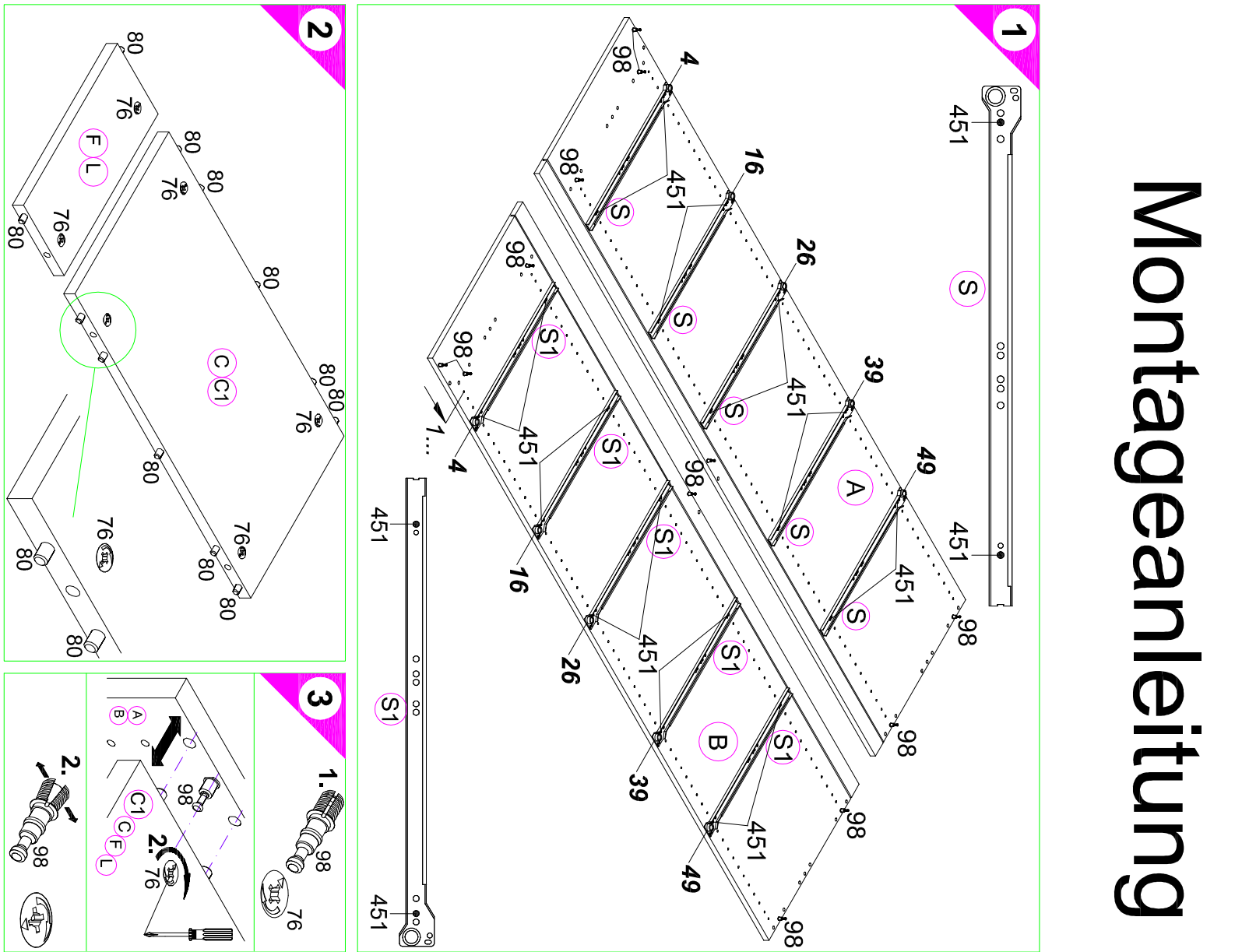
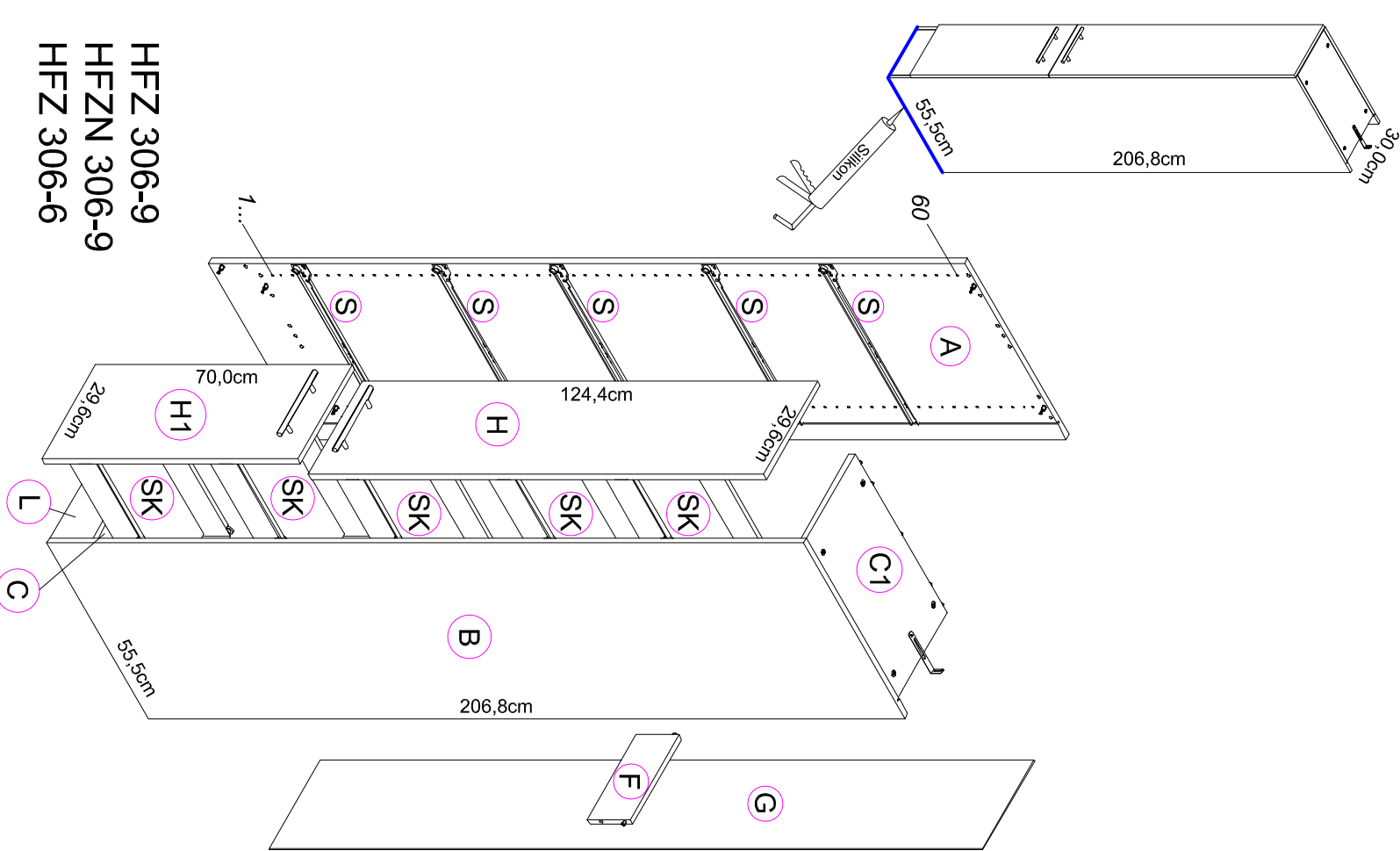
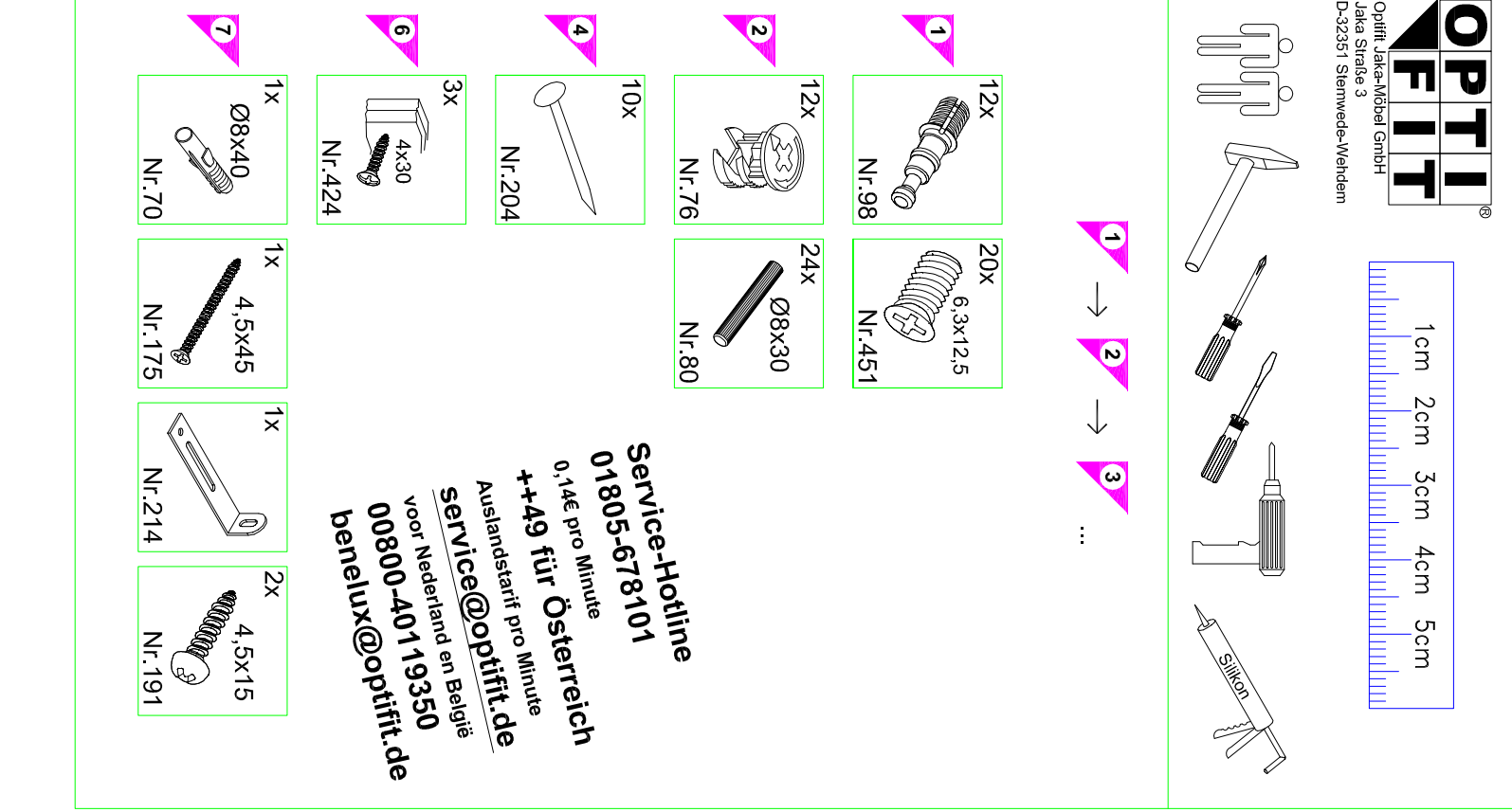

Montageanleitung

Ersatzteile/Spare parts/pièces de rechange/Reserveonderdelen/Piezas de recambio/Ricambi/Ricambi/Запасные части/Części zamienné/rótalkatészék/Náhradní části/Nadomestni deli/varaosat/reservdelar

30cm HFZ306-9 **A** E961011 **B** E961012 **C** E954216 **C1** E954216 **F** E970976 **G** E970023 **H** E940607 **H1** E940596 **L** E970976 **S** E946003 **S1** E946004

30cm HFZ306-6 **A** E961011 **B** E961012 **C** E954216 **C1** E954216 **F** E970976 **G** E970023 **H** E980607 **H1** E980596 **L** E970976 **S** E946003 **S1** E946004

500650.1C 08/12 sl **SK**

Montageanleitung

Service-Hotline
 01805-678101
 0,14€ pro Minute
++49 für Österreich
 Auslandstarif pro Minute
service@optifit.de
 voor Nederland en België
00800-40119350
benelux@optifit.de

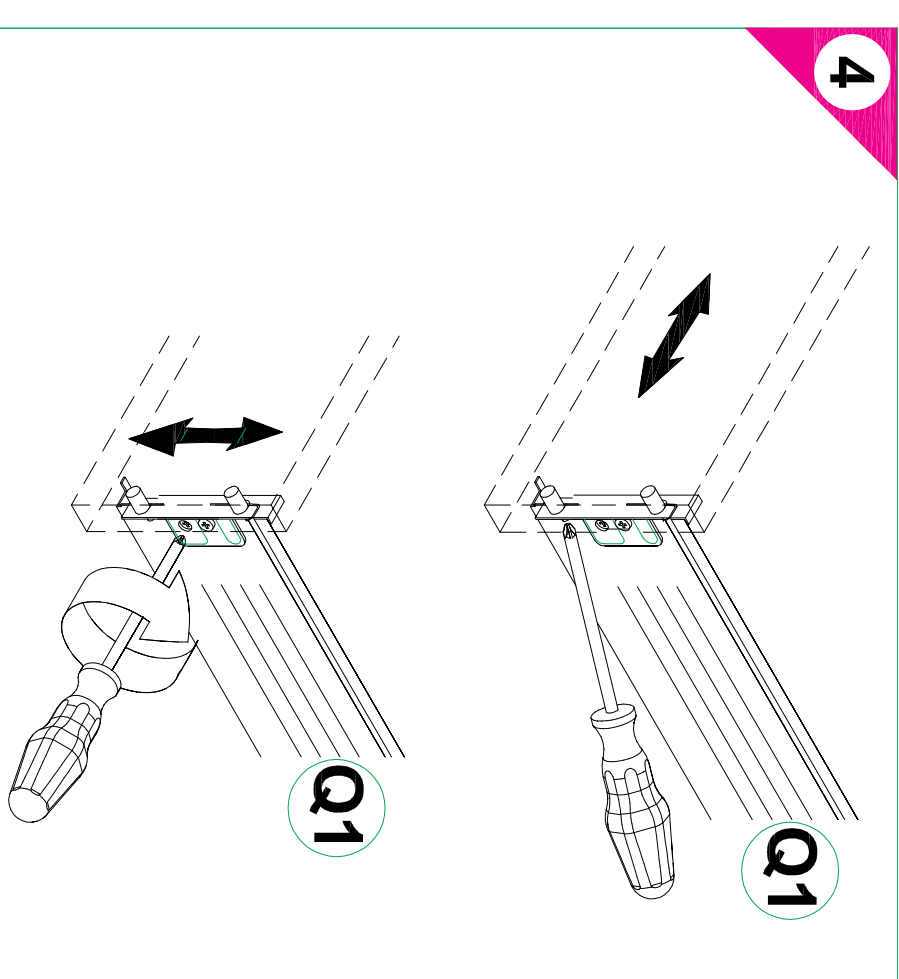
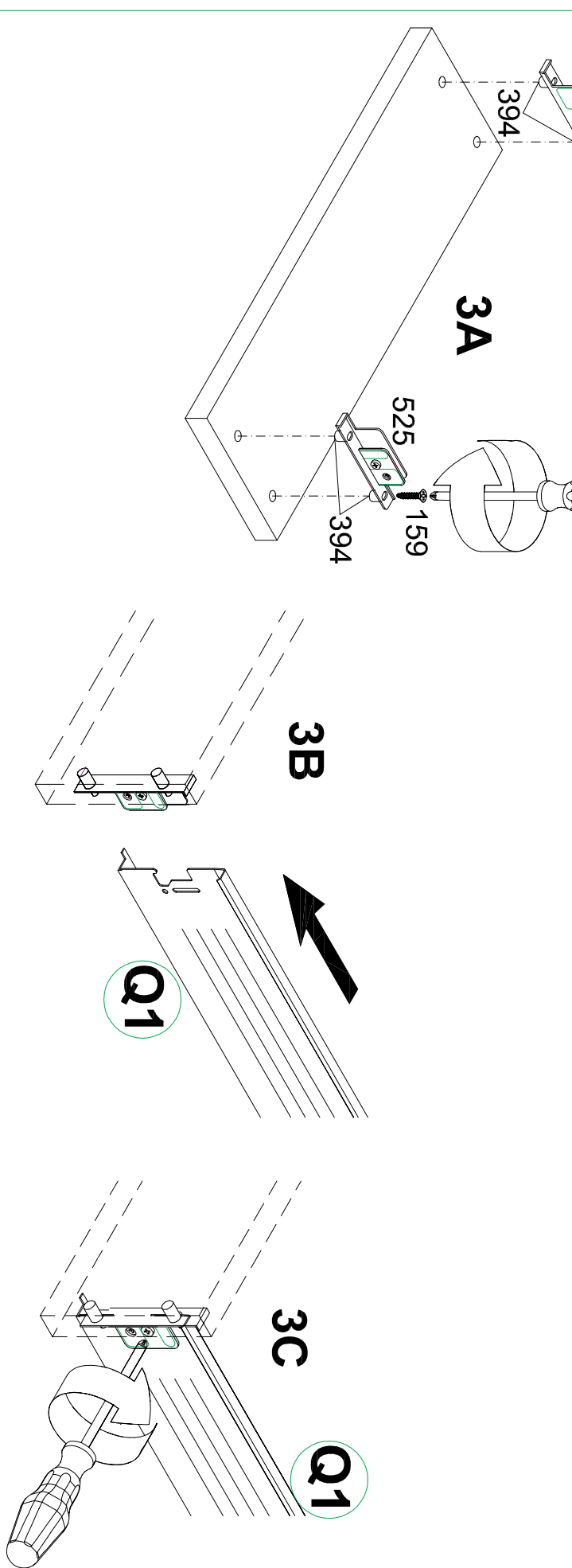
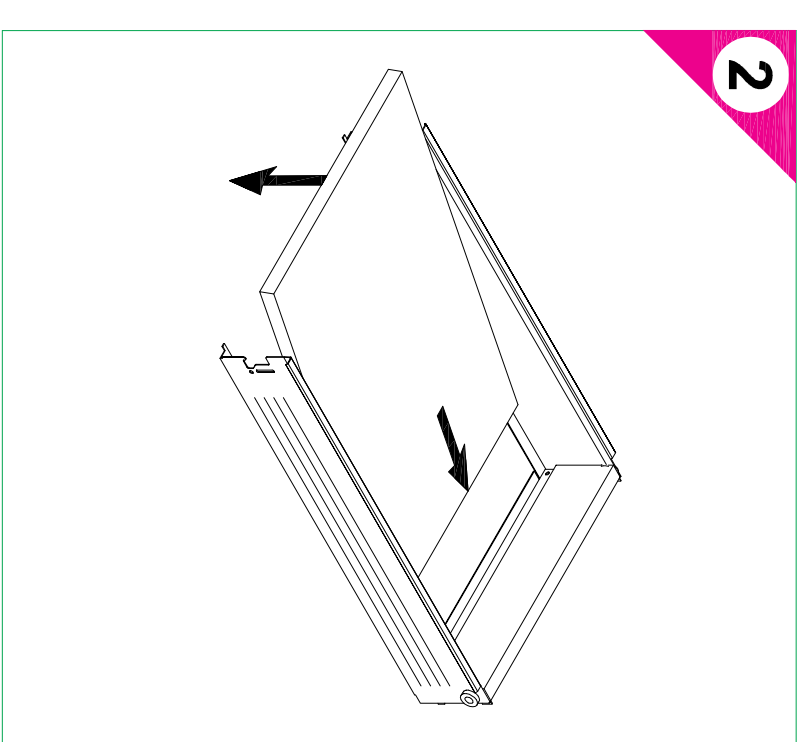
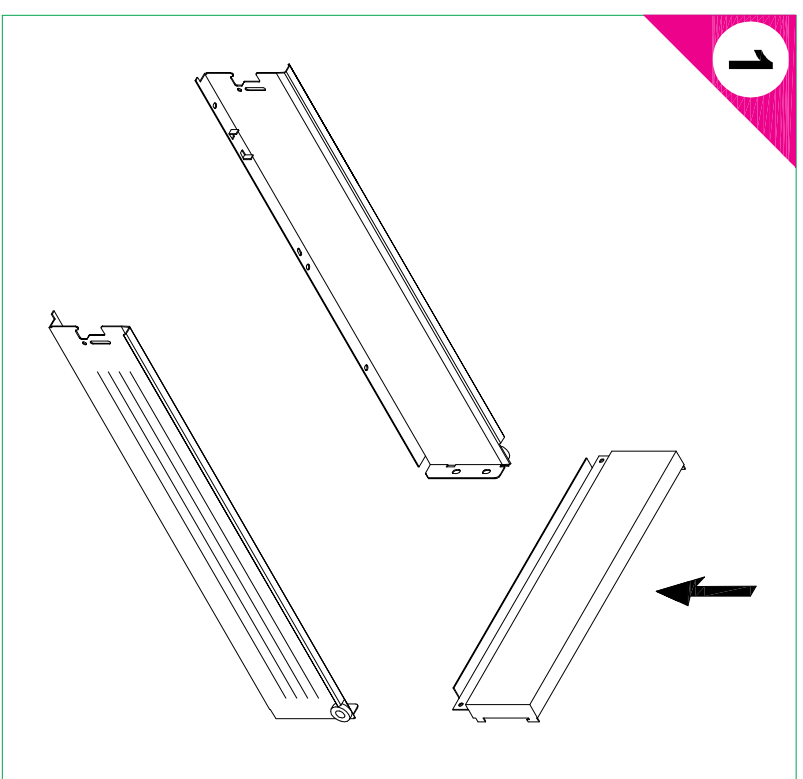
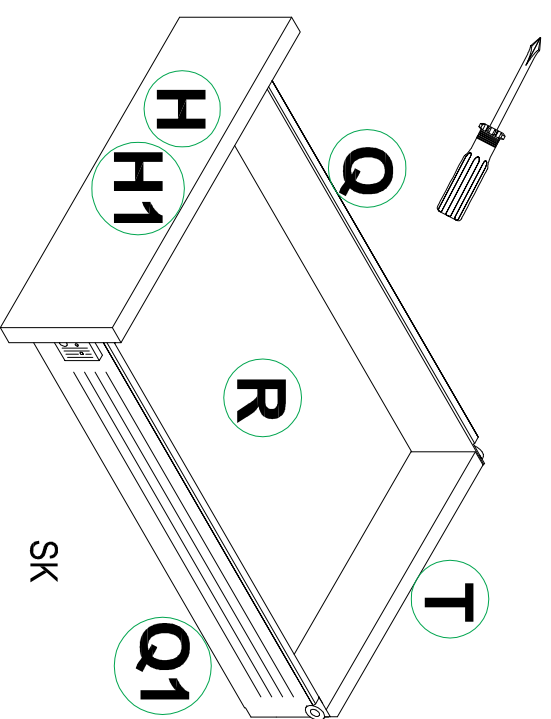

Ersatzteile/Spare parts/pièces de rechange/Reserveonderdelen/Piezas de recambio/Ricambi/Запасные части/Części zamienné/pótalkatrészek/Náhradní části/Nadomestni deli/Varaosot/reservdelar
 30cm SK | Q E946001 | Q1 E946002 | R E941902 | T E946019

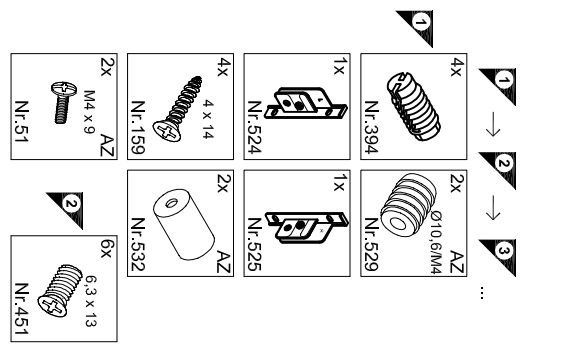
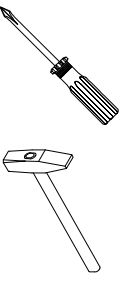

Variante I METABOX

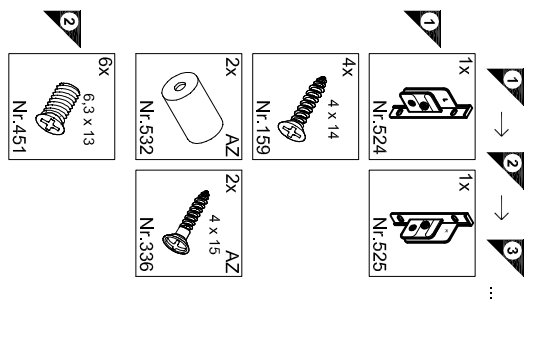
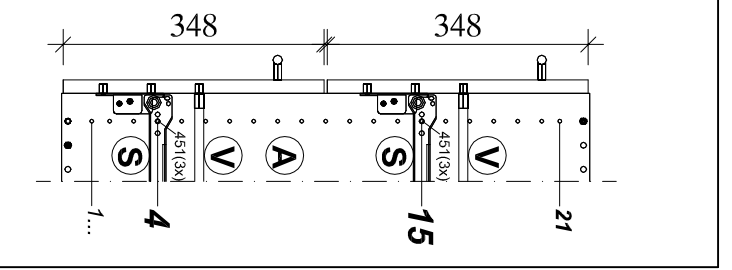
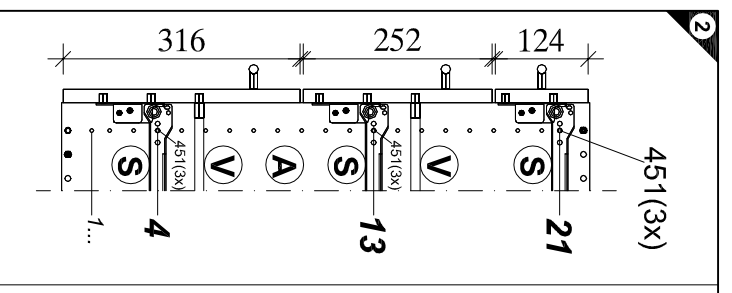
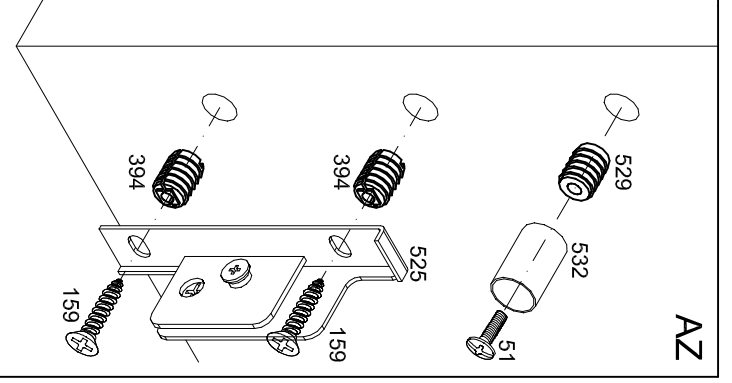
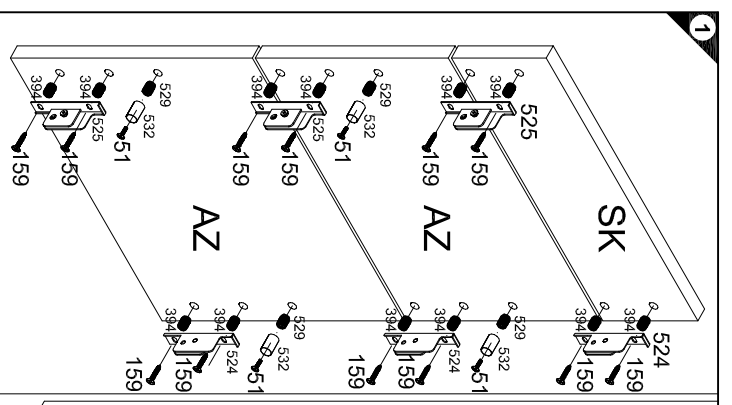
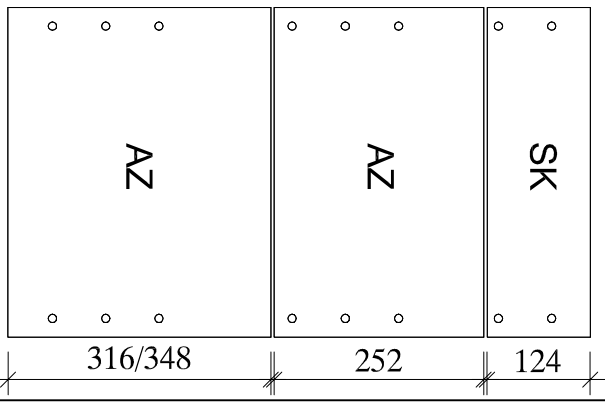

Variante 2 METABOX

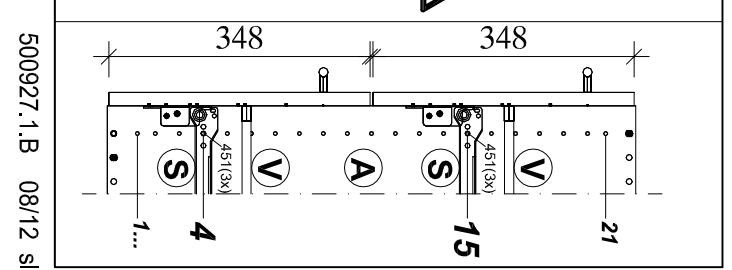
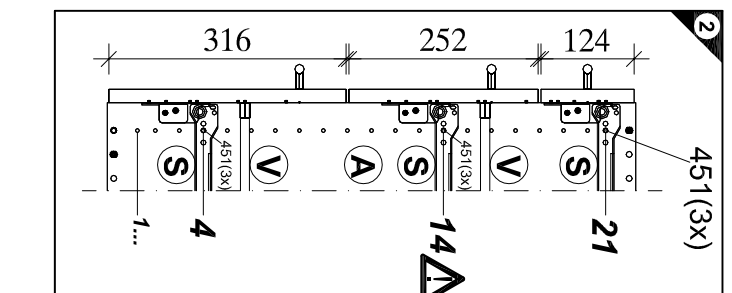
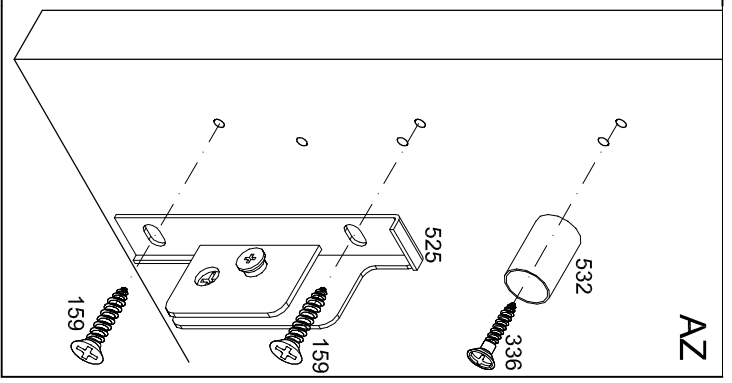
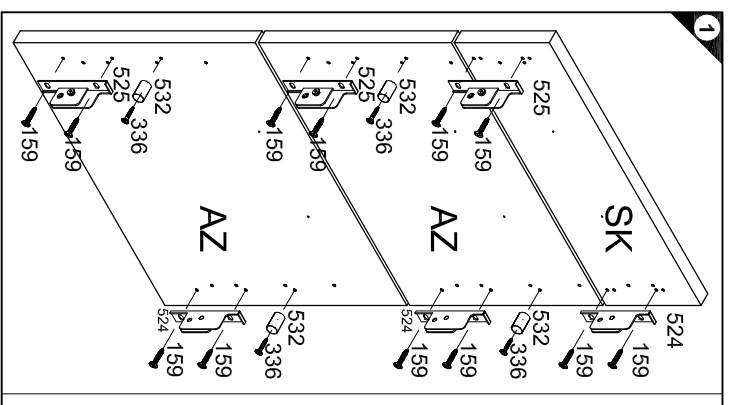
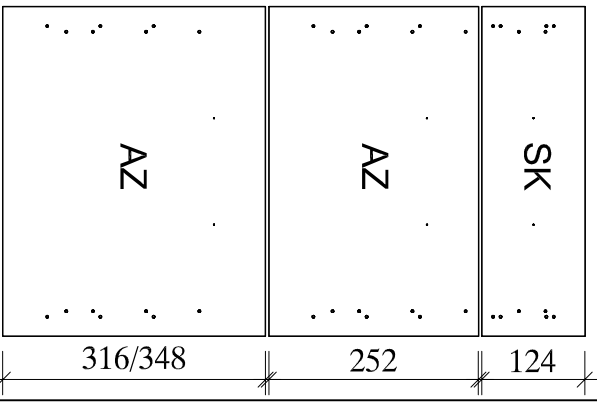

Opfit Jaka-Winkel GmbH
Jaka Straße 3
D-32351 Stemwede-Wehden

Montageanleitung



Optifit Jaka-Möbel GmbH
Jaka Straße 3
D-32351 Stemwede-Wehden

Service-Hotline
01805-678101
0,14€ pro Minute
++49 für Österreich
Auslandstarif pro Minute
service@optifit.de
voor Nederland en België
00800-40119350
benelux@optifit.de

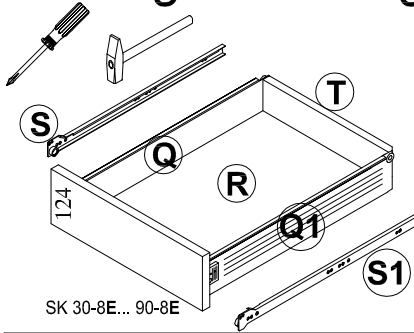

SK 30-8E... 90-8E

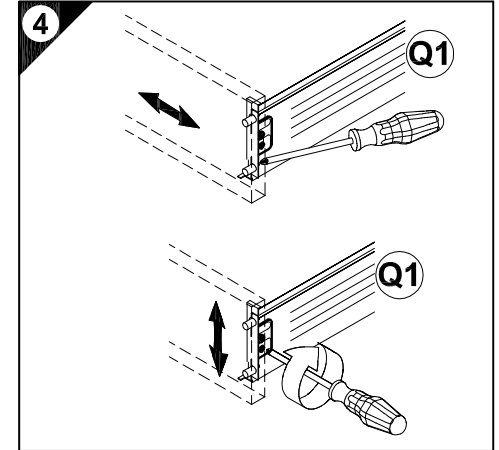
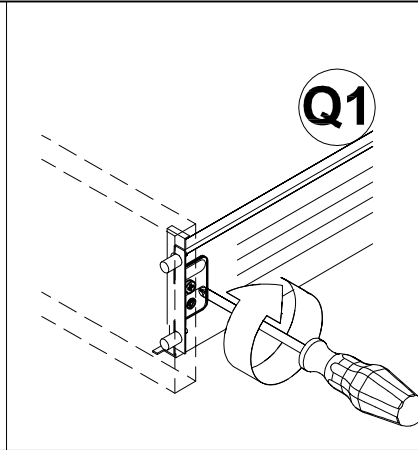
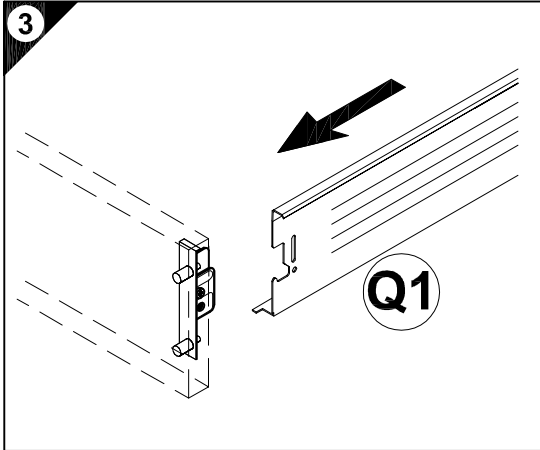
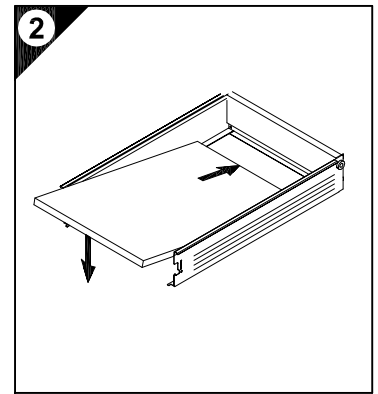
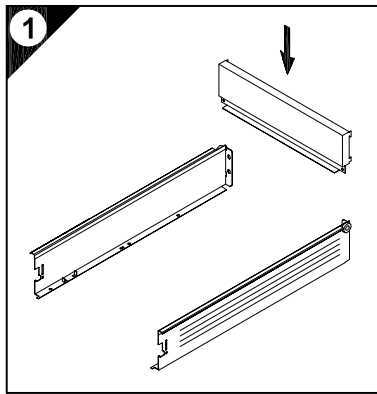

Ersatzteile/Spare parts/pièces de rechange/Reserveonderdelen/Piezas de recambio/Ricambi/Запасные части/Części zamienn/pótalkatrészek/Náhradní části/Nadomestni deli/varaosat/reservdelar

30cm SK 30-8E	Q E946001	Q1 E946002	R E941902	S E946003	S1 E946004	T E946019
40cm SK 40-8E	Q E946001	Q1 E946002	R E941907	S E946003	S1 E946004	T E946020
50cm SK 50-8E	Q E946001	Q1 E946002	R E941908	S E946003	S1 E946004	T E946021
60cm SK 60-8E	Q E946001	Q1 E946002	R E941909	S E946003	S1 E946004	T E946017
90cm SK 90-8E	Q E946001	Q1 E946002	R E941913	S E946003	S1 E946004	T E946018

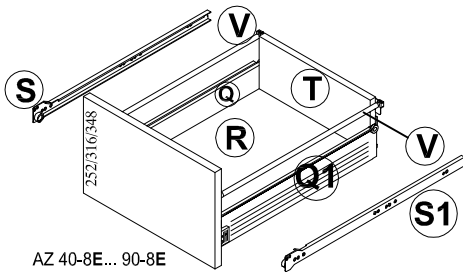

AZ 40-8E... 90-8E

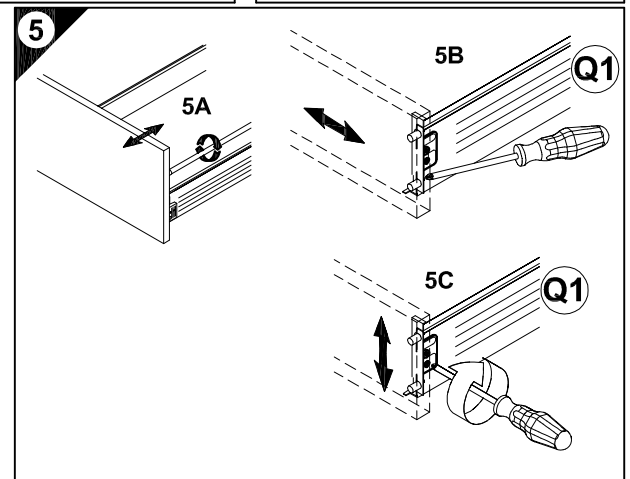
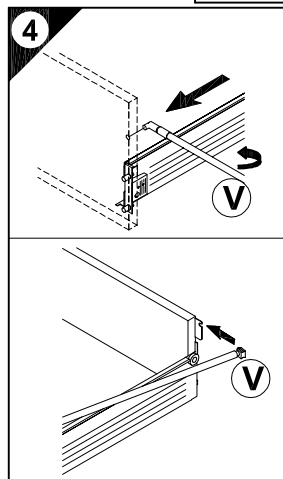
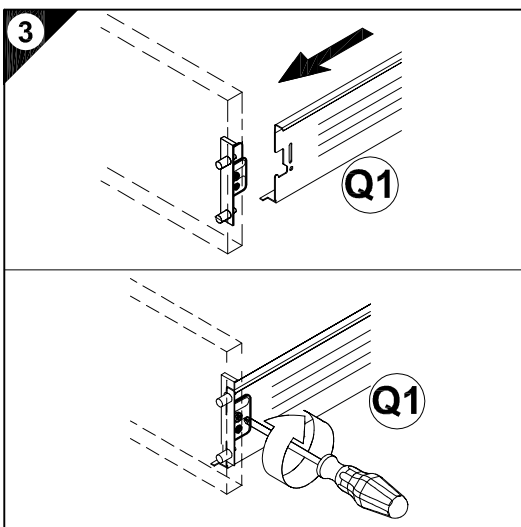
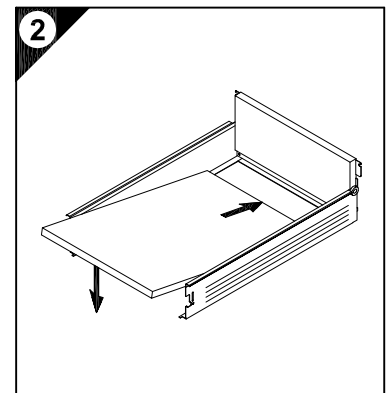
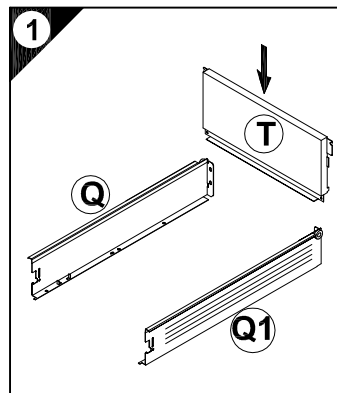

Ersatzteile/Spare parts/pièces de rechange/Reserveonderdelen/Piezas de recambio/Ricambi/Запасные части/Części zamienn/pótalkatrészek/Náhradní části/Nadomestni deli/varaosat/reservdelar

40cm AZ 40-8E	Q E946001	Q1 E946002	R E941907	S E946003	S1 E946004	T E946022	V E946006
50cm AZ 50-8E	Q E946001	Q1 E946002	R E941908	S E946003	S1 E946004	T E946023	V E946006
60cm AZ 60-8E	Q E946001	Q1 E946002	R E941909	S E946003	S1 E946004	T E946024	V E946006
80cm AZ 80-8E	Q E946001	Q1 E946002	R E941911	S E946003	S1 E946004	T E946025	V E946006
90cm AZ 90-8E	Q E946001	Q1 E946002	R E941913	S E946003	S1 E946004	T E946013	V E946006



- | | | | | | |
|----------|---|---|---|---|---|
| 8x | 1 | → | 2 | → | 3 |
| 8x | 1 | → | 2 | → | 3 |
| 12x | 1 | → | 2 | → | 3 |
| 8x | 1 | → | 2 | → | 3 |
| 14x | 1 | → | 2 | → | 3 |
| 10x | 1 | → | 2 | → | 3 |
| 1x | 1 | → | 2 | → | 3 |
| 8x | 1 | → | 2 | → | 3 |
| 14x | 1 | → | 2 | → | 3 |
| 8x | 1 | → | 2 | → | 3 |
| 8x | 1 | → | 2 | → | 3 |
| 6,3 x 13 | 1 | → | 2 | → | 3 |
| 8x30 | 1 | → | 2 | → | 3 |
| 8x30 | 1 | → | 2 | → | 3 |
| 4x15 | 1 | → | 2 | → | 3 |
| 4x30 | 1 | → | 2 | → | 3 |
| 4x30 | 1 | → | 2 | → | 3 |
| M4 x 9 | 1 | → | 2 | → | 3 |
| 4x30 | 1 | → | 2 | → | 3 |
| 4x30 | 1 | → | 2 | → | 3 |

Montageanleitung

40cm UO 436-6
50cm UO 536-6

40cm U 436-6
50cm U 536-6

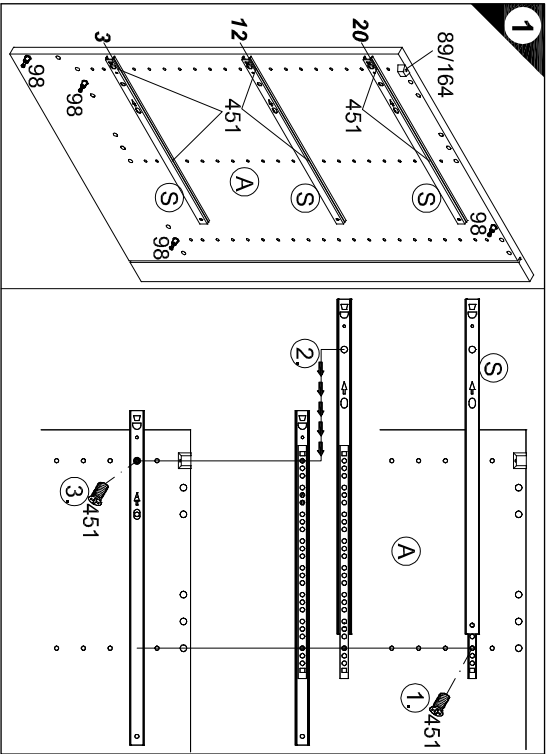
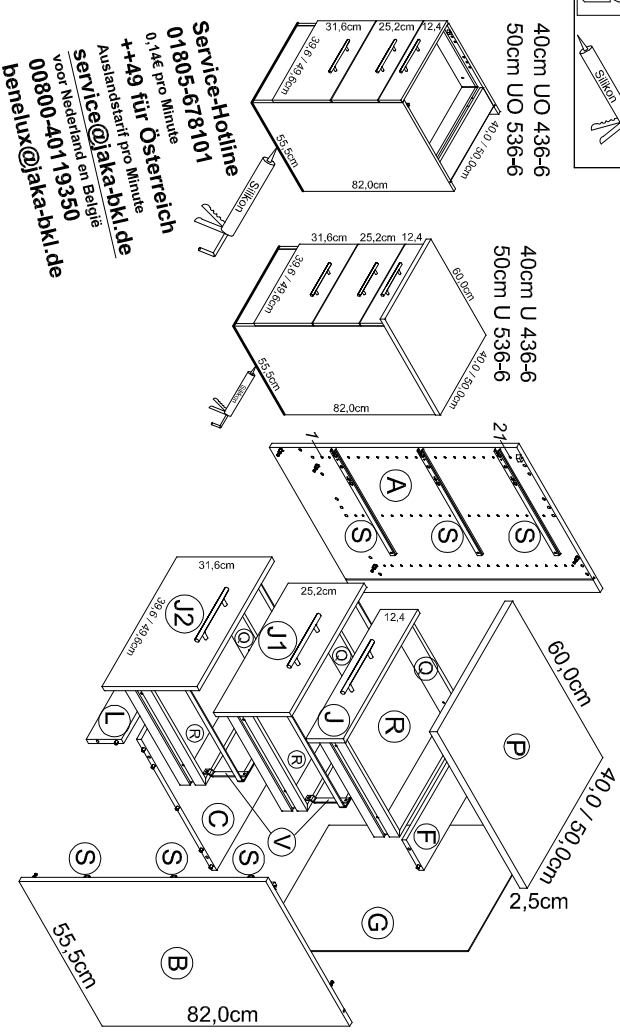

Service-Hotline
01805-678101
0,14€ pro Minute
++49 für Österreich
Auslandstarif pro Minute
service@jaka-bil.de
vor. Niederland en België
00800-40119350
benelux@jaka-bil.de

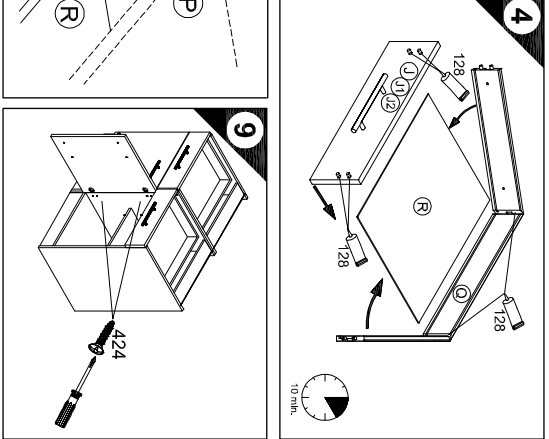
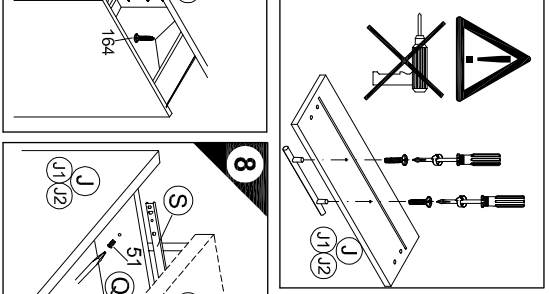
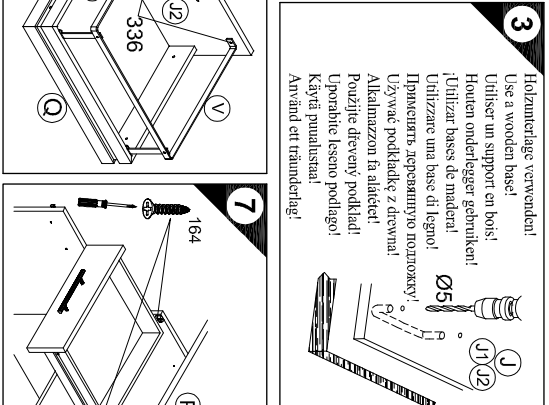
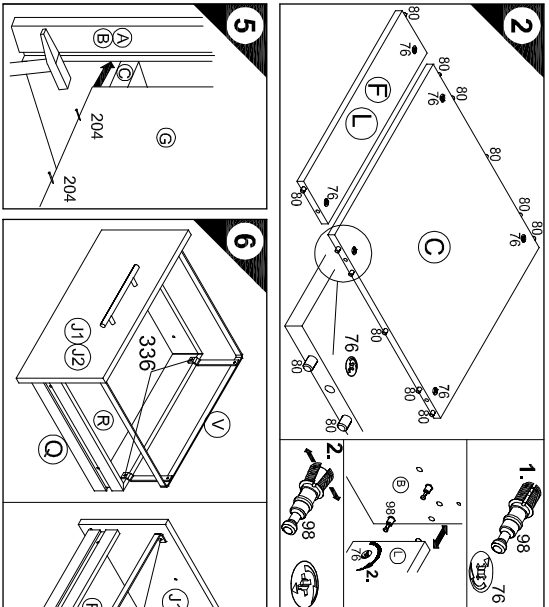

- Ersatzteile/Spare parts/pièces de rechange/Reserveonderdelen/Piezas de recambio/Ricambi/Запчасти/Замачиве частин/Części zamienné/póialkatárszék/Náhradní části/Nadomesini della/Varaosat/reservdelar
- | | | | | | | | | | | | | | | | | | | | | | | | | | | | | |
|---------|-----|---------|-----|---------|-----|---------|-----|---------|-----|---------|-----|---------|------|---------|------|---------|-----|---------|-----|---------|-----|---------|-----|---------|-----|---------|-----|---------|
| UO436-6 | (A) | E961021 | (B) | E961022 | (C) | E954215 | (F) | E970975 | (G) | E970010 | (J) | E980564 | (J1) | E980593 | (J2) | E980643 | (L) | E970975 | (Q) | E446131 | (R) | E971152 | (S) | E446205 | (V) | E446153 | | |
| U436-6 | (A) | E961021 | (B) | E961022 | (C) | E954215 | (F) | E970975 | (G) | E970010 | (J) | E980564 | (J1) | E980593 | (J2) | E980643 | (L) | E970975 | (Q) | E441105 | (R) | E446131 | (S) | E446205 | (V) | E446153 | | |
| UO536-6 | (A) | E961021 | (B) | E961022 | (C) | E954224 | (F) | E970974 | (G) | E970117 | (J) | E980563 | (J1) | E980592 | (J2) | E980644 | (L) | E970974 | (P) | E971151 | (R) | E971151 | (S) | E446205 | (V) | E446155 | | |
| U536-6 | (A) | E961021 | (B) | E961022 | (C) | E954224 | (F) | E970974 | (G) | E970117 | (J) | E980563 | (J1) | E980592 | (J2) | E980644 | (L) | E970974 | (P) | E441104 | (Q) | E446132 | (R) | E971151 | (S) | E446205 | (V) | E446155 |

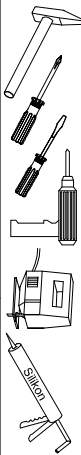

Montageanleitung

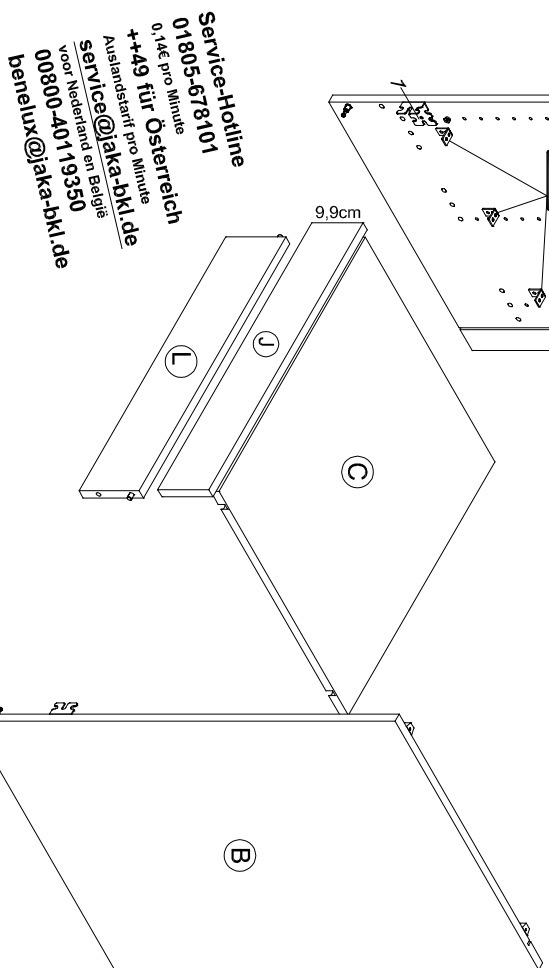
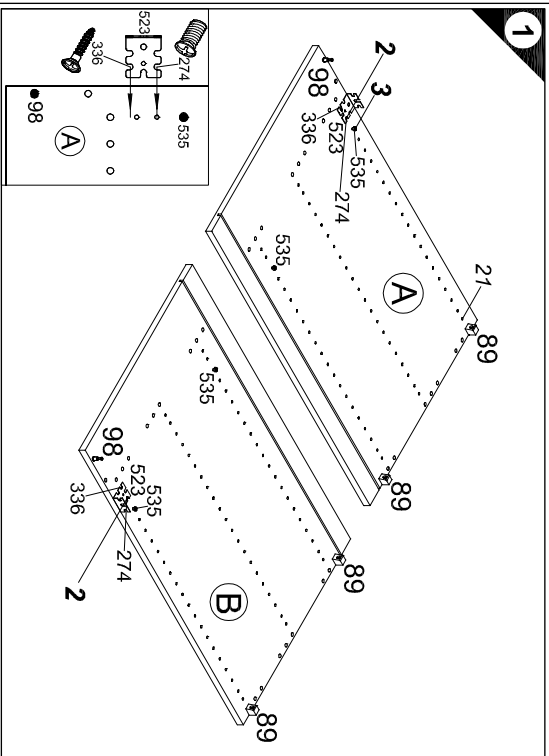
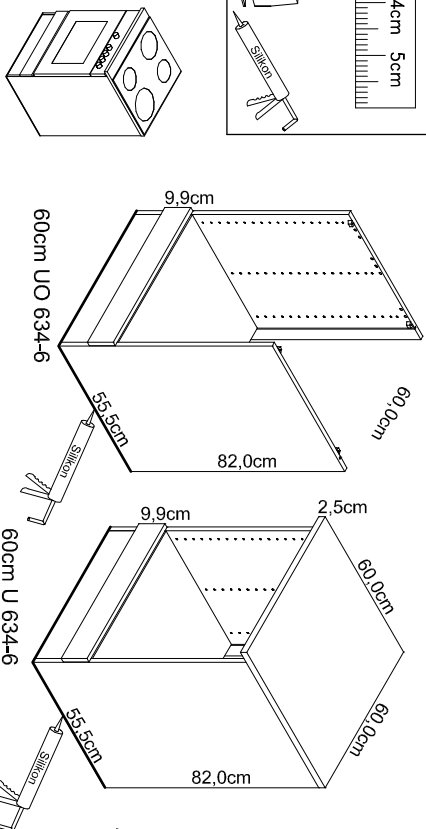

Service-Hotline
01805-678101
0,14€ pro Minute
++49 für Österreich
Auslandstarif pro Minute
service@jaka-bkl.de
voor Nederland en België
00800-40119350
benelux@jaka-bkl.de

- 1x 4x Nr. 98
- 2x 4x Nr. 89
- 4x 4x Nr. 535
- 2x 2x Nr. 523
- 2x 2x 6,3x13 Nr. 274
- 2x 2x 4x15 Nr. 336
- 2x 2x Ø8x30 Nr. 80
- 2x 4x Nr. 76
- 2x 4x Nr. 536
- 6x 6x Nr. 315
- 12x 12x 3,5x15 Nr. 181
- 2x 2x 6,3x13 Nr. 274
- 4x 4x 4x30 Nr. 164
- 2x 2x 4x30 Nr. 424

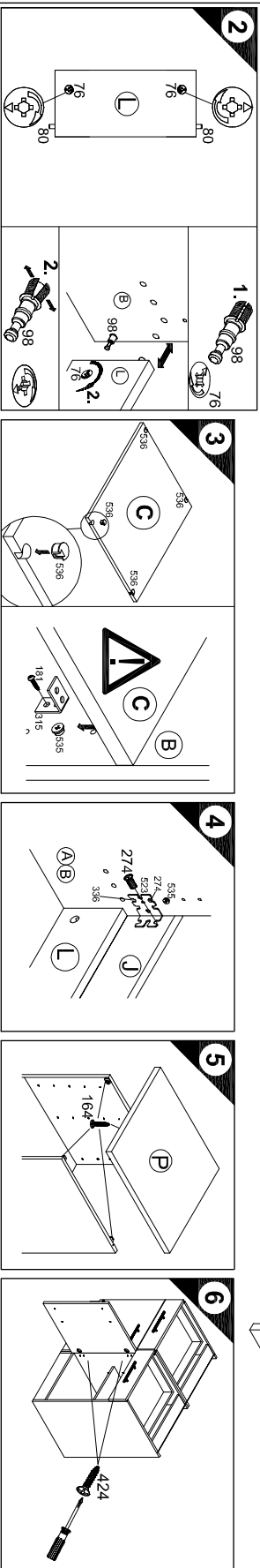

Ersatzteile/Spare parts/pièces de rechange/Reserveonderdelen/Piezas de recambio/Ricambi/Запасные части/Części zamienne/pótkalkatészkek/Náhradní části/Nadomestini deli/varaosat/reservdelar

U0634-6 (A) E961021 (B) E961022 (C) E950223 (J) E980560 (L) E970973 (E) E961021 (B) E961022 (C) E950223 (J) E980560 (L) E970973 (P) E441103

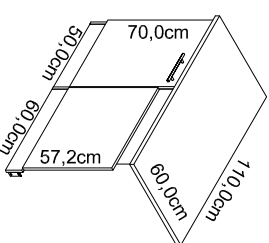
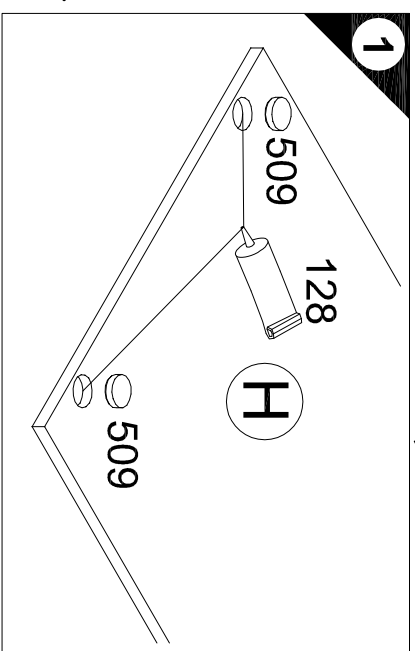
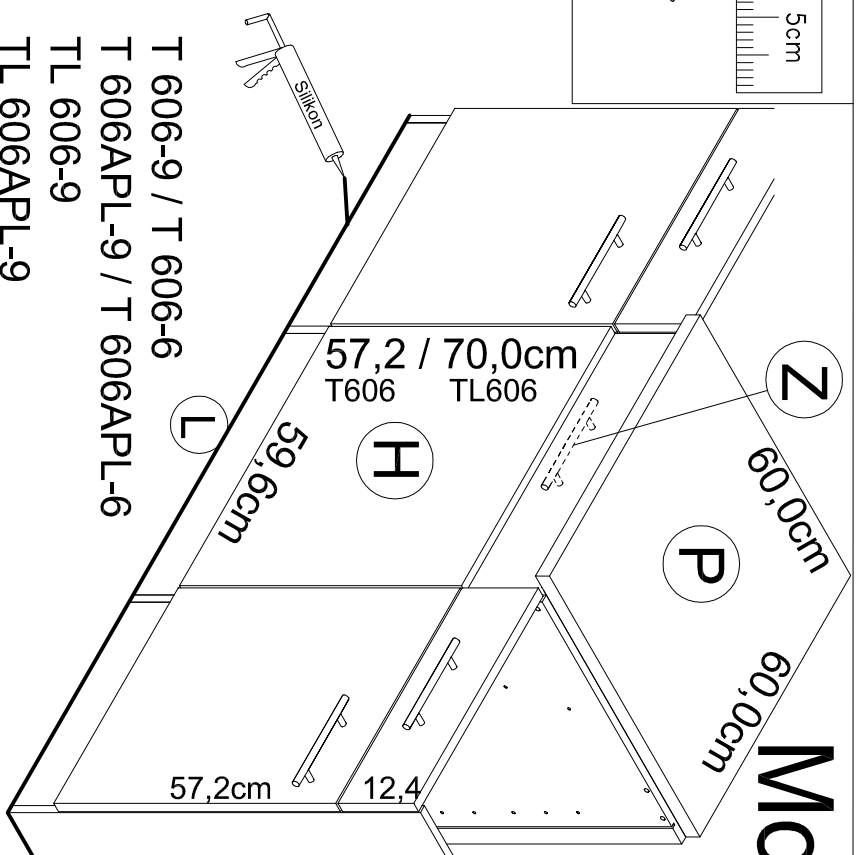
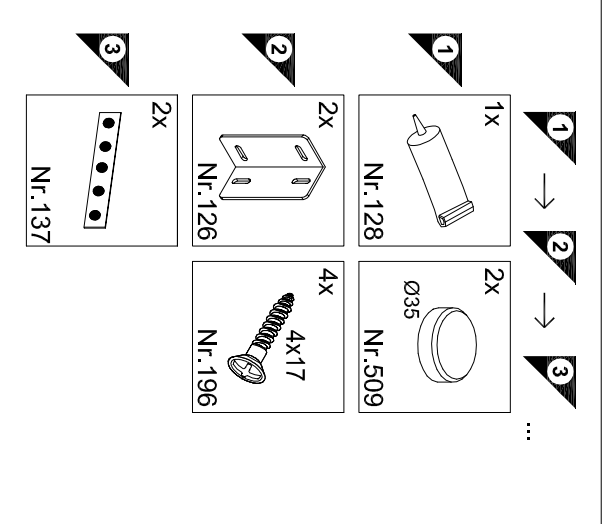
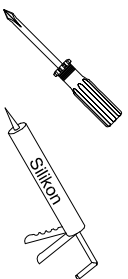

Montageanleitung

Service-Hotline
01805-678101
0,14€ pro Min.
++49 für Österreich

Auslandstarif pro Min.
service@optifit.de
vor: Niederland en België
00800-40119350
benelux@optifit.de

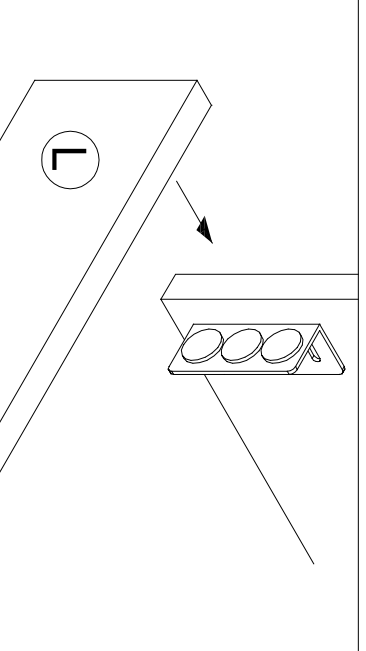
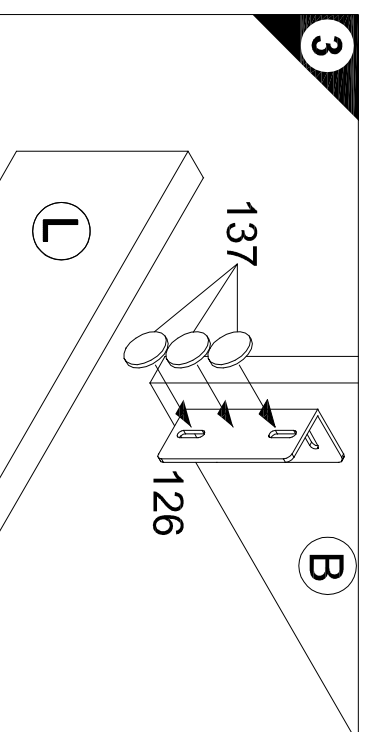
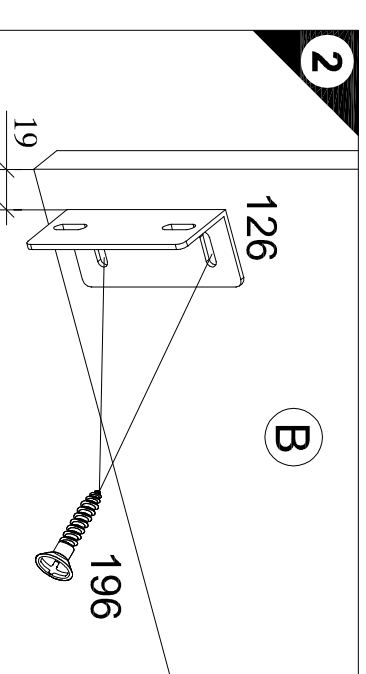

Ersatzteile/Spare parts/pièces de rechange/Reserveonderdelen/Piezas de recambio/Ricambi/Запасные части/Čeští záměny/półalkatrzeszek/Náhradní části/Nadomesni dell'varosot/reservdelar

T 606-9 (H) E940611 (L) E946048 (H) E980611 (L) E946048 (H) E940611 (L) E946048 (P) E540103
 T 606APL-9 (H) E940611 (L) E946048 (P) E540103
 T 606APL-6 (H) E980611 (L) E946048 (P) E441103
 TL 606APL-9 (H) E940621 (L) E946048 (P) E540103 (Z) E947100

TL 606-9 (H) E940621 (L) E946048 (Z) E947100

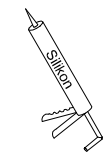
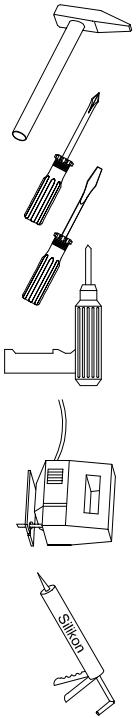
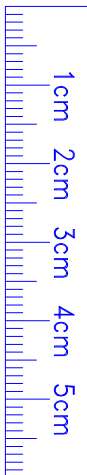

Montageanleitung

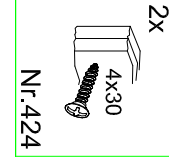
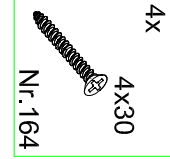
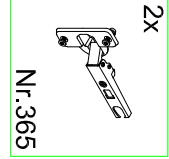
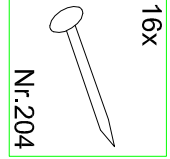
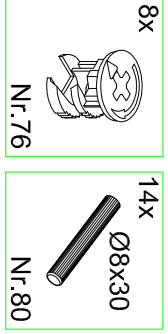
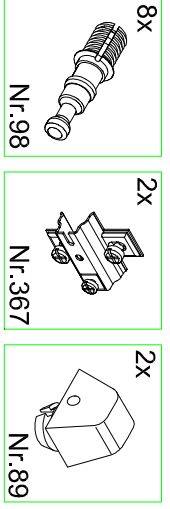
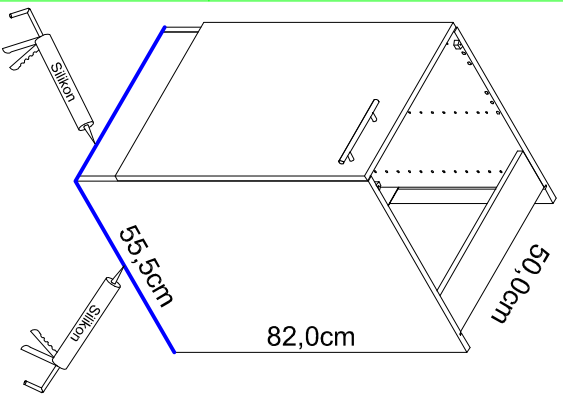
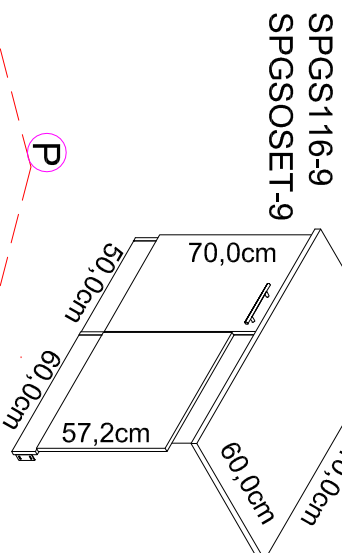

Service-Hotline
01805-678101
0,14€ pro Minute
++49 für Österreich
Auslandstarif pro Minute
service@optifit.de
voor Nederland en België
00800-40119350
benelux@optifit.de

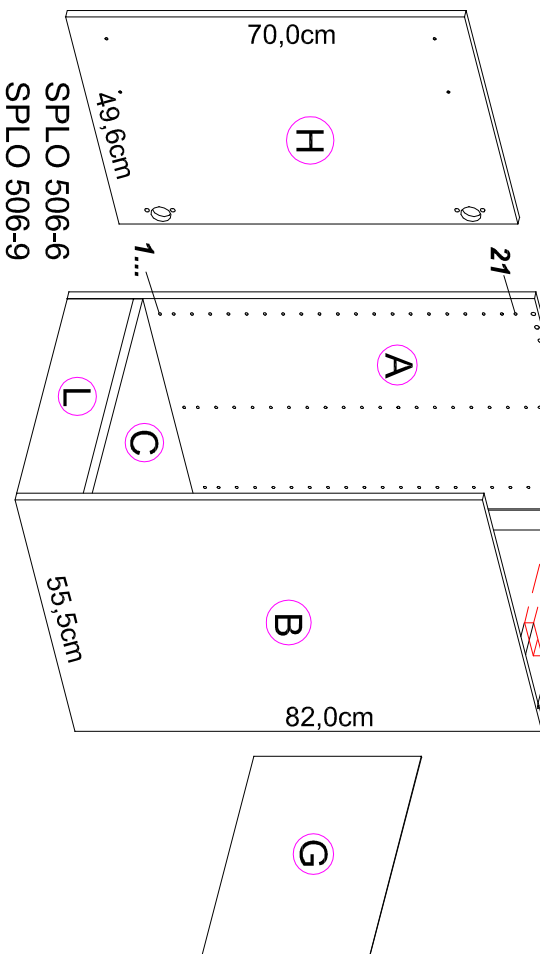

SPL0 506-6
SPL0 506-9

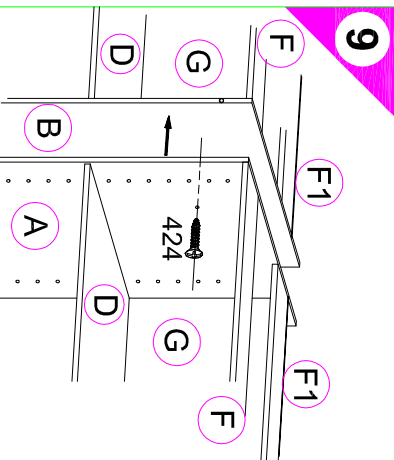
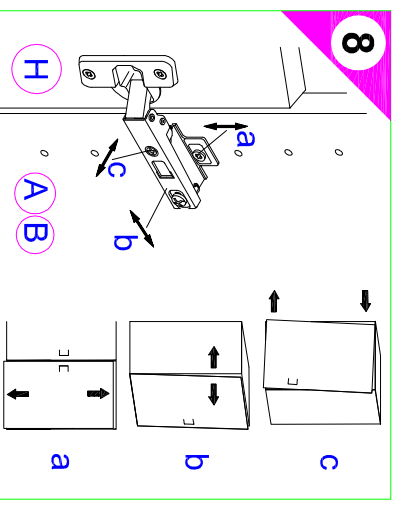
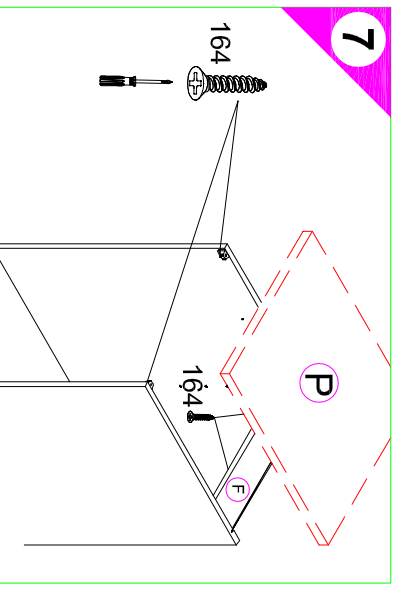
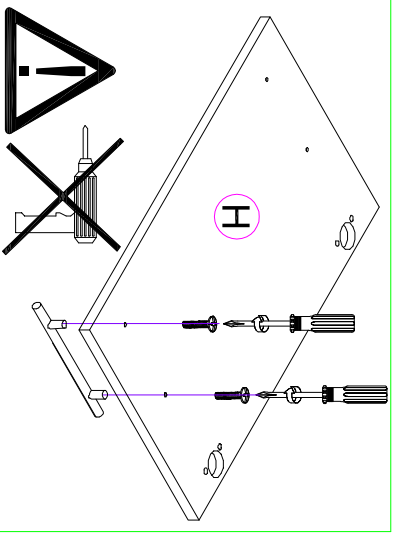
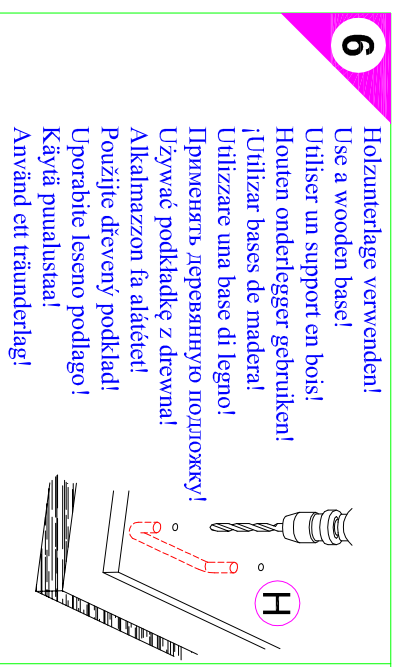
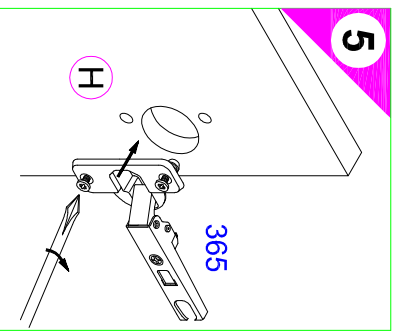
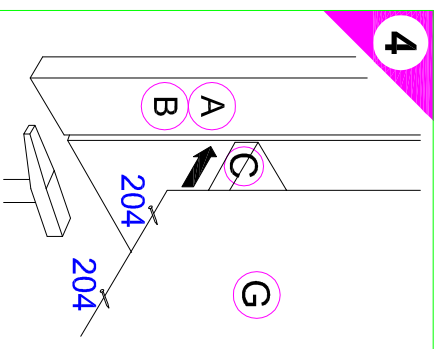
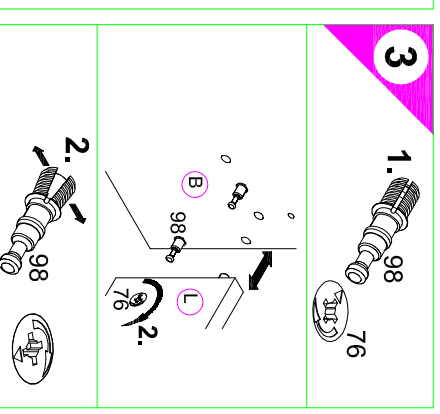
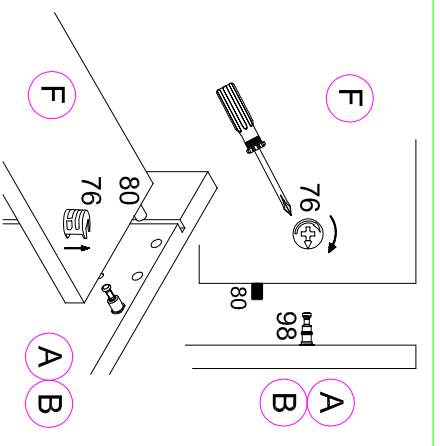
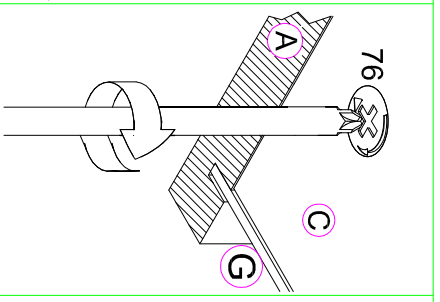
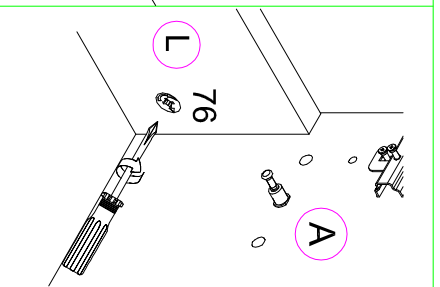
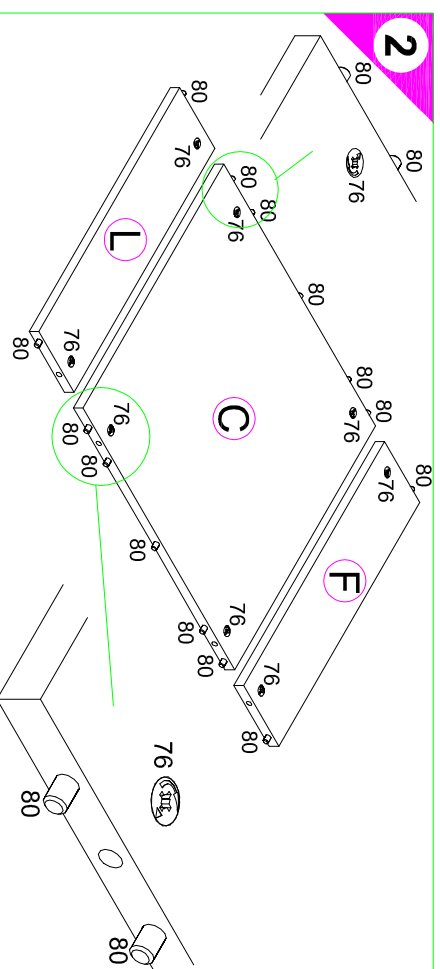
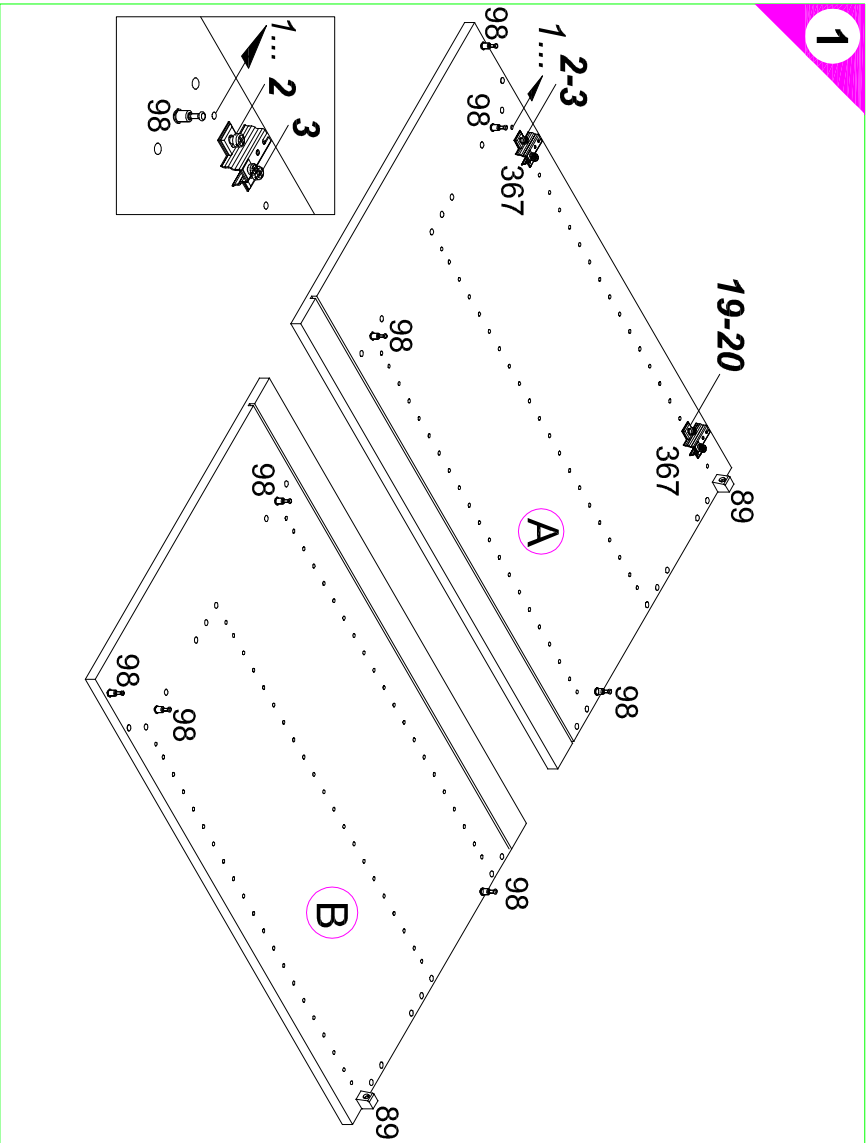

6
Holzunterlage verwenden!
Use a wooden base!
Utiliser un support en bois!
Houten onderlegger gebruiken!
! Utilizar bases de madera!
Utilizzare una base di legno!
Применять деревянную подложку!
Używać podkładkę z drewna!
Alkalmaazon fa alátétel!
Ровніть деревну підкладку!
Upravitie leseno podlago!
Käytä puualustaa!
Använd ett träunderlag!

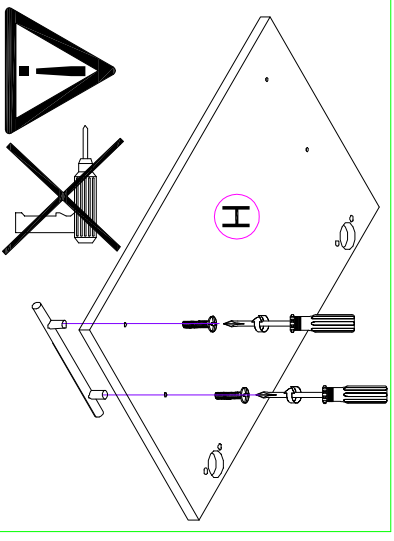

- Ersatzteile/ Spare parts/pièces de rechange/Reserveonderdelen/Piezas de recambio/Ricambi/Запасные части/Części zamienne/pótkalkatészek/Náhradní části/Nadomestni deli/varaosat/reservdelar
- 50cm SPL0506-6
 - 50cm SPL0506-9
 - A E961021
 - B E961022
 - C E954224
 - F E970974
 - G E954224
 - H E970974
 - A E961021
 - B E961022
 - C E954224
 - F E970974
 - G E445043
 - H E940622
 - D E970974
 - E970974
 - E940622
 - E970974
 - E970974
 - E970974

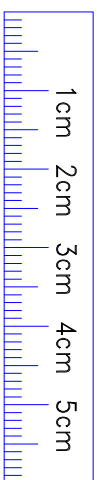

1 → 2 → 3 ...

- 1 8x Nr. 98
- 2x OGH556-6 OGH656-6 Nr. 107
- 2x Nr. 367
- 4x Nr. 502
- 2x Nr. 367
- 4x Nr. 502
- 8x Nr. 76
- 16x Ø8x30 Nr. 80
- 4x Nr. 146
- 2x Nr. 278
- 4x 4x30 Nr. 164
- 10x Nr. 204
- 2x Nr. 365
- 2x 5,2x55 Nr. 69
- 2x Ø8x40 Nr. 70
- 2x Nr. 424

Service-Hotline
01905-678101
0,14€ pro Minute
+149 für Österreich
Auslandstarif pro Minute
Service@optifit.de
voor Nederland en België
00800-40119350
benelux@optifit.de

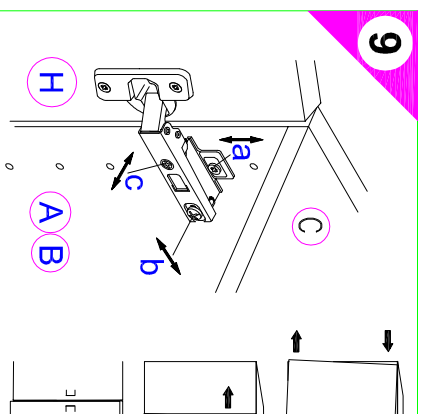
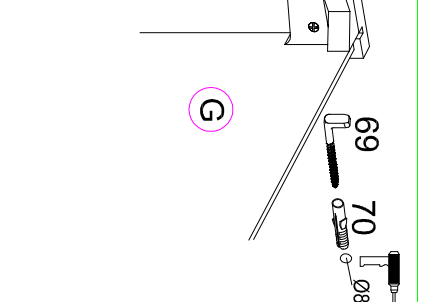
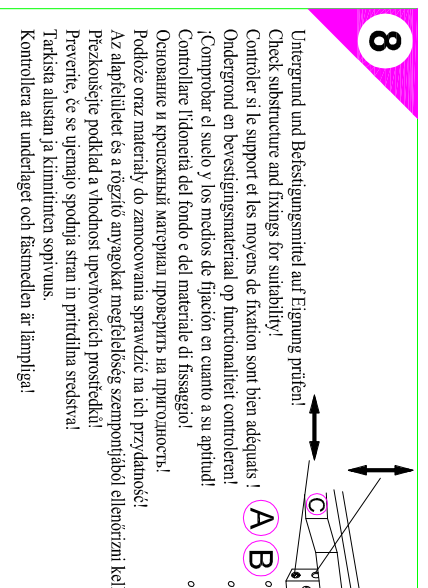
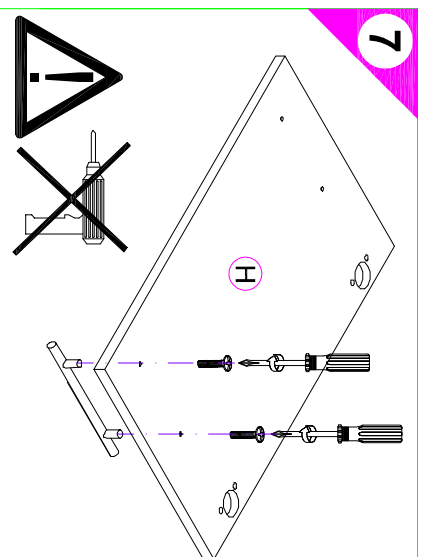
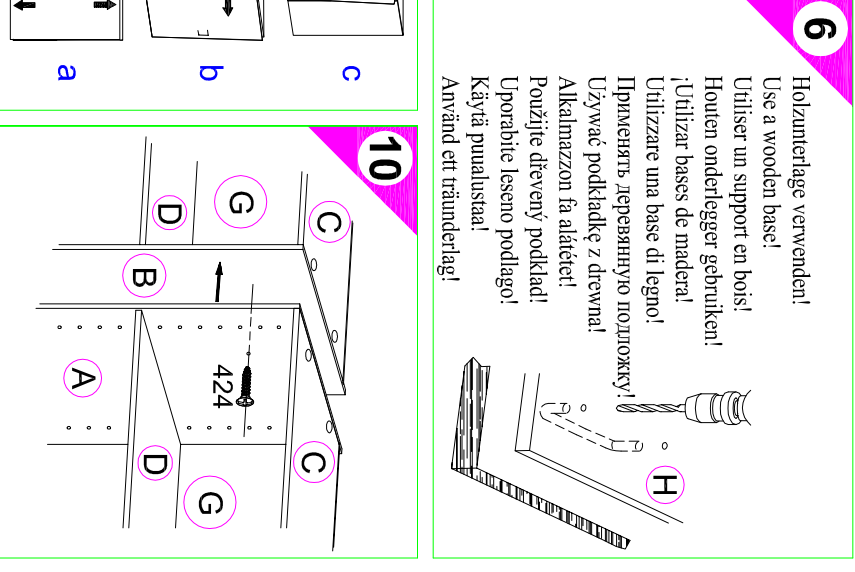
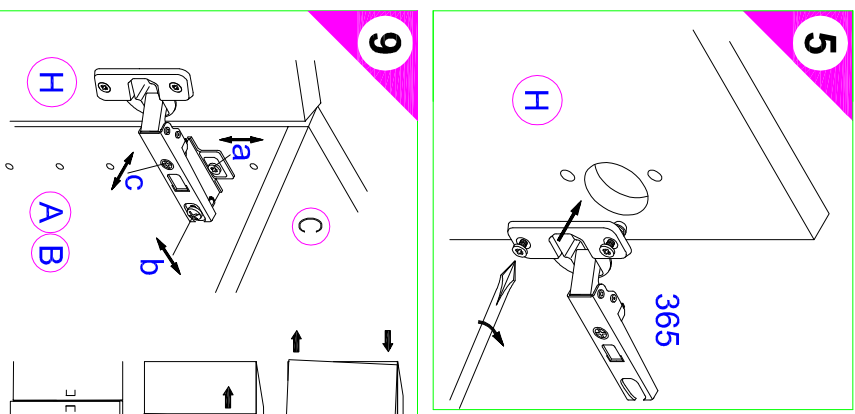
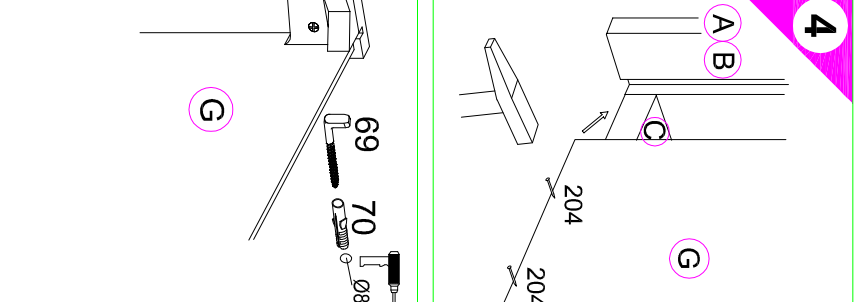
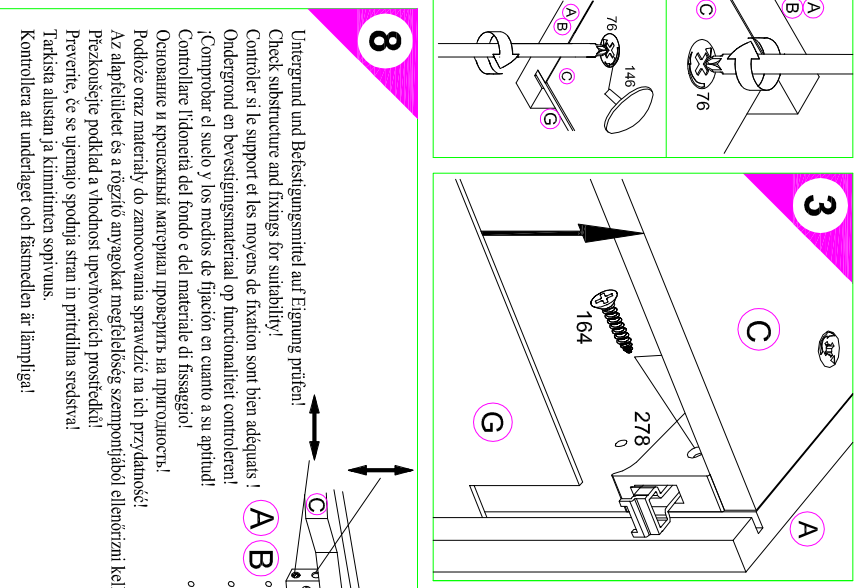
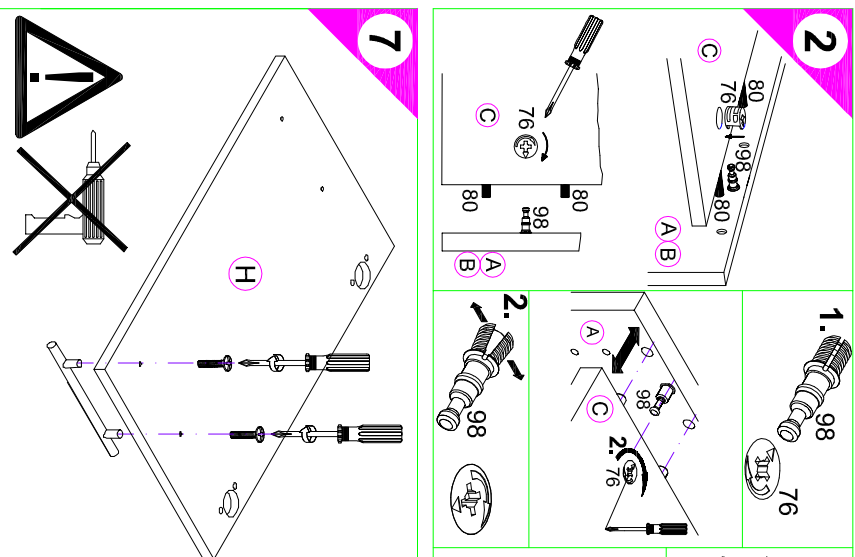
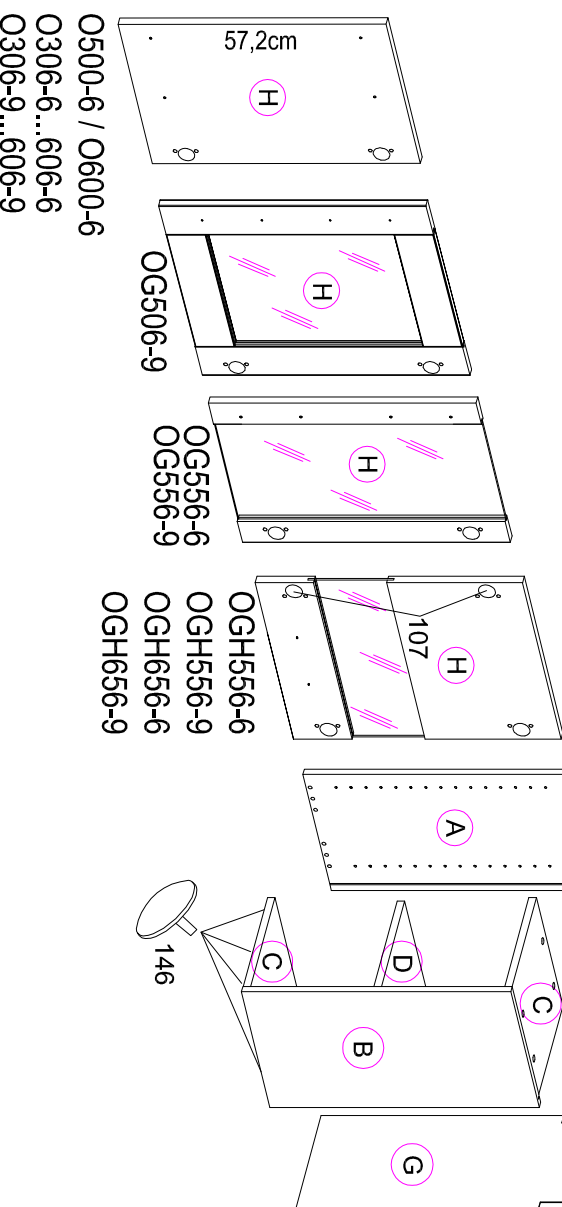
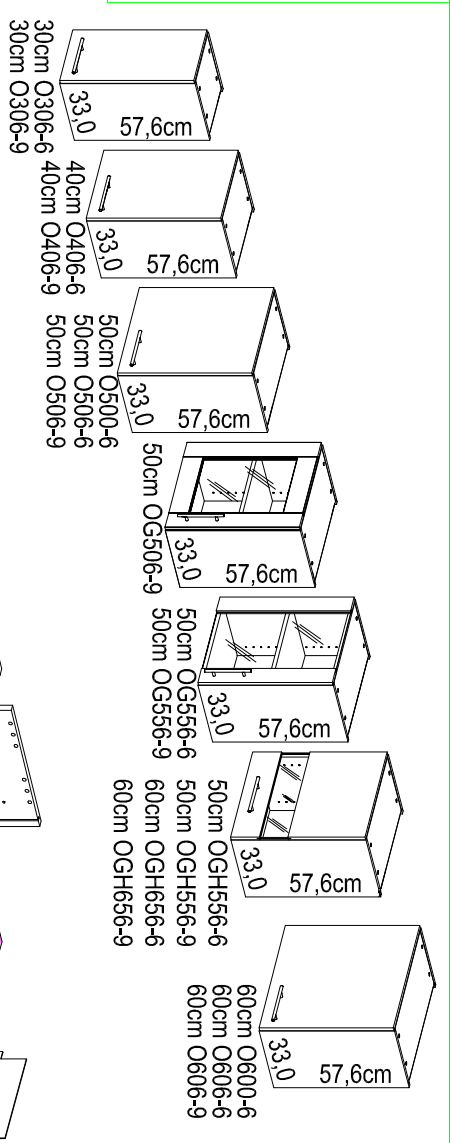

Montageanleitung

- Ersatzteile/ Spare parts/pièces de rechange/Reserveonderdelen/Piezas de recambio/Ricambi/Запасные части/Części zamienné/pótkatészék/Náhradní části/Nadomestni deli/Varaosat/reservdelar**
- | | | | | | | | | | | | | | |
|---------------------|-----------|-----------|-----------|-----------|-----------|-----------|--------------|-----------|-----------|-----------|-----------|-----------|-----------|
| 30cm 0306-6/ -9 | A E940036 | B E940036 | C E941236 | D E940336 | G E971015 | H E980614 | 50cm 0G506-9 | A E940036 | B E940036 | C E941234 | D E940334 | G E970032 | H E940647 |
| 40cm 0406-6/ -9 | A E940036 | B E940036 | C E941235 | D E940335 | G E971014 | H E980613 | 0GH556-6/ -9 | A E940036 | B E940036 | C E941234 | D E940334 | G E970032 | H E980655 |
| 50cm 0500/0506-6... | A E940036 | B E940036 | C E941234 | D E940334 | G E970032 | H E980612 | 0GH656-6/ -9 | A E940036 | B E940036 | C E941233 | D E940333 | G E971012 | H E980657 |
| 60cm 0600/0606-6... | A E940036 | B E940036 | C E941233 | D E940333 | G E971012 | H E980611 | | | | | | | |
| 50cm 0G556-6/ -9 | A E940036 | B E940036 | C E941234 | D E940334 | G E970032 | H E940647 | | | | | | | |

SERVICEKARTE

VH

Liebe Kundin, lieber Kunde,

obwohl wir unsere Möbel vor der Auslieferung einer eingehenden Endkontrolle unterziehen, kann es vorkommen, dass einmal ein Zubehörteil fehlt oder während des Transports beschädigt wird. Senden sie den Artikel bitte nicht zurück, sondern fordern sie einfach Ersatz für das Einzelteil bei unserer Kundenhotline an. Die Telefonnummern finden sie auf den Serviceseiten im Katalog.

Bitte benennen sie die Teile wie sie auf ihrer Aufbauanleitung angegeben sind. Fügen sie auch **Artikelnummer, Modellnamen und Farbnummer** bei. **Siehe Beispiel.**

Wir werden ihre Anforderung sofort bearbeiten und ihnen das Ersatzteil umgehend zusenden.

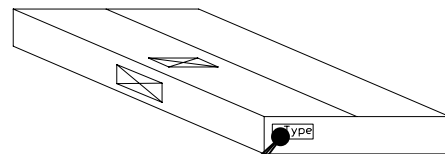
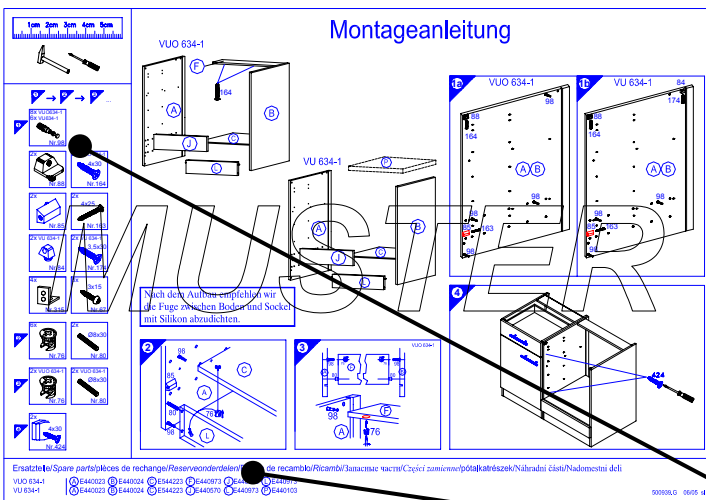

Muster - Bestellung		
Artikelnummer	123 456	
Modellname	Unterschrank VU634	
Farbe	TA 01	
Benötigte Ersatzteile:		
Bezeichnung	Nr.	Anzahl
Beschlagteil	98	2
Teil B	E 440 023	1

Bitte entnehmen sie die notwendige Ersatzteilnummer der Aufbauanleitung die zum Möbel gehört!

Kundendaten	
Kundennummer	
Name	
Vorname	
Strasse	
Haus-Nr.	
PLZ	
Ort	
Rechnungsdatum	
Tel. für Rückfragen	
Notizen:	

Ersatzteilbestellung		
Artikelnummer		
Modellname		
Farbe		
Benötigte Ersatzteile:		
Bezeichnung	Nr.	Anzahl
Grund der Ersatzteilanforderung:		

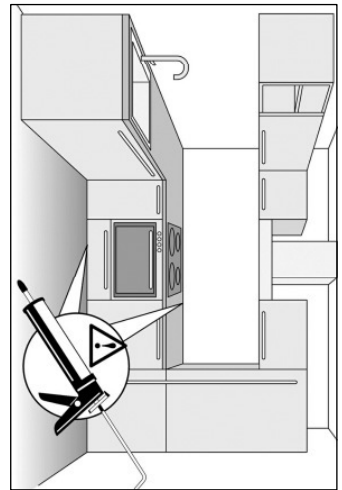
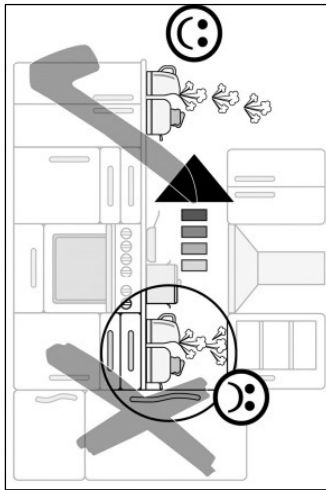
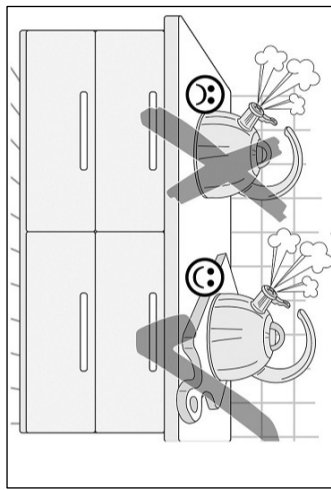
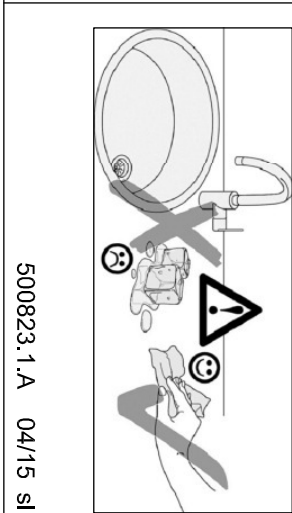
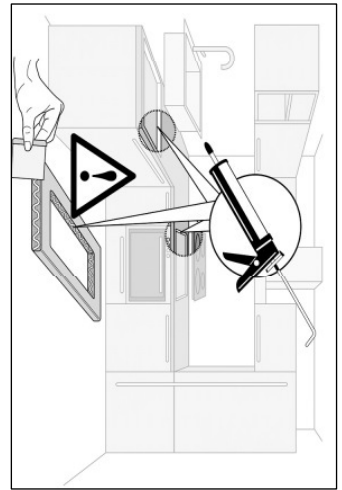
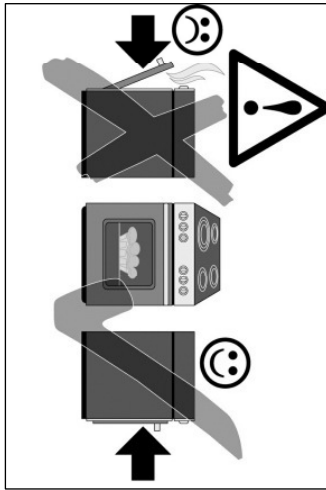
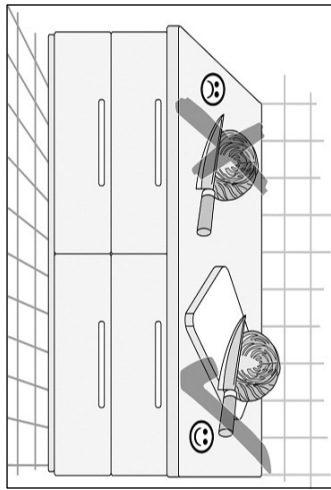
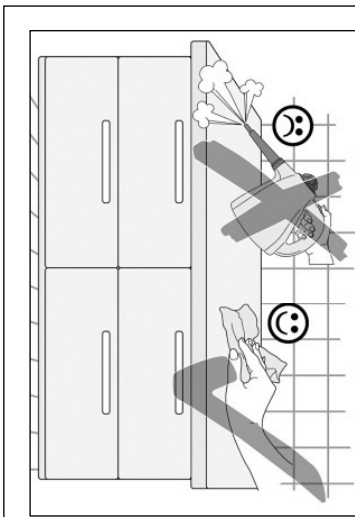

500823.1.A 04/15 SI

D Pflegehinweise

Kunststoff-Oberflächen:

Kunststoffbeschichtete Oberflächen/Fronten lassen sich mit haushaltsüblichen Reinigungsmitteln pflegen. Am besten geht das mit einem weichen Tuch, handwarmen Wasser und etwas Spülmittel. Verwenden Sie keine polierenden Reinigungsmittel oder harte Schwämme! Hartnäckige Flecken, wie Fettspritzer, Lack- oder Klebstoffreste, sind mit einem handelsüblichen Kunststoffreiniger zu beseitigen. Vor dem ersten Gebrauch dieser Mittel empfiehlt es sich, diese an einer nicht sichtbaren Stelle zu prüfen!

Glänzende Fronten: Diese Fronten nie trocken reinigen!
Die Verwendung von schleifenden Reinigungsmitteln (Mikrofaserlappen, Scheuerschwämme etc.) können zu erhöhter Bildung von Kratzern führen und sind kein Reklamationsgrund. Verwenden Sie daher am besten ein staubfreies Tuch oder ein feuchtes Fensterleder.

Einbauspülen und Herdmulden:

Einbauspülen, Herdmulden sowie alle nicht genannten Artikel aus rostfreiem Stahl pflegen Sie am besten mit einem Schwamm oder einem Vlies Tuch unter Verwendung von Spülmittel oder mit den bekannten Spezialpflegemitteln (Edelstahlreiniger, Metall-Polish). Bei Einbauspülen aus anderen Materialien wie Porzellan, Kunststoff, Acryl-Keramik sowie bei Edelstahlspülen milde Spül- oder Reinigungsmittel verwenden.

Bitte beachten Sie außerdem die speziellen Pflegehinweise der Hersteller!

Glaskeramik-Kochfelder:

Hartnäckige Verschmutzungen, Kalk- und Wasserflecken sowie glänzende Topfabrieb beseitigen Sie mit dem vom Hersteller empfohlenen Spezialreiniger (z.B. Cerafix, Stahlfix). Festgebrannte Verkrustungen (Zucker, Salz oder zuckerhaltige Speisereste) entfernen Sie, in noch heißem Zustand, mit einem Glasschaber.

Beachten Sie hierzu auch die Bedienungsanleitung des Geräteherstellers!

Griffe:

Verzichten Sie auf lösungsmittelhaltige und aluminiumschädigende Substanzen sowie auf Essigreiniger, da diese zu einer nicht mehr entfernbaren Fleckenbildung führen können.

GB Care instructions

Synthetic Surfaces:

Synthetic finishes on surfaces/fronts can be cared for with common household cleaners. It's best to use a soft cloth, hand warm water and a little washing-up liquid. Do not use any polishing cleaners or hard sponges! Stubborn marks, such as grease splashes, paint or adhesive residues can be removed with common, commercially available synthetic materials cleaners. However, it is recommended that these be tested on an inconspicuous area before using them for the first time!

Gloss Fronts: Never clean these fronts in the dry state!

Fitted sink units and all other articles made of stainless steel are best cleaned using a sponge or a fleece cloth with a washing-up liquid or known specialty cleaner (stainless steel cleaner, metal polish). Use mild washing-up or cleaning liquids on fitted sinks made of other materials, such as porcelain, synthetic material, acrylic ceramic as well as stainless steel. In addition, make sure to always follow the specific care instructions provided by the respective manufacturer!

Ceramic Glass Hobs:

Stubborn marks, limescale and water spots and shiny marks left by pots are best removed with special cleaners as recommended by the manufacturer. Use a glass scraper to remove burnt-on marks (sugar, salt or food spillages containing sugar) while still hot.

Please also refer to the operating instructions provided by the appliance manufacturer!

Handles:

Avoid using substances containing solvents or which are harmful to aluminum, as well as cleaners containing vinegar, as these can cause permanent discolouration.

NL Onderhoudsinstructies

Kunststof-opervlakken:

Oppervlakken/fronten met een kunststof coating kunnen met een gangbaar huishoudelijk reinigingsmiddel worden verzorgd. Dat gaat het beste met een zacht doekje, handwarm water en een beetje afwasmiddel. Gebruik geen polijstende reinigingsmiddelen of harde sponjes! Hardnekkige vlekken, resten van lak of lijm, moeten met een gangbaar reinigingsmiddel voor kunststof worden verwijderd. Voor het eerste gebruik van dit middel is het aan te bevelen om dit op een niet zichtbare plek uit te proberen!

Glänzende fronten: Deze fronten nooit droog reinigen!

Het gebruik van schurende reinigingsmiddelen (microvezeldoekjes, schuursponjes etc.) kunnen tot snellere vorming van krasjes leiden en zijn geen reden voor een reclamatie. Gebruik daarom het beste een stofvrij doekje of een vochtige zeem.

Inbouwgootstenen en kookplaten:

Inbouwgootstenen, kookplaten en alle niet genoemde artikelen van roestvast staal reinigt u het beste met een sponsje of een vlieddoek met afwasmiddel of met de bekende speciale reinigers (vrs-reiniger, metaal-polish). Bij gootstenen van andere materialen zoals porselein, kunststof, acryl-keramiek en bij gootstenen van edelstaal milde afwas- of reinigingsmiddelen gebruiken. Neem bovendien de speciale reinigingsinstructies van de fabrikanten in acht!

Glaskeramische kookplaten:

Hardnekkig vuil, kalk- en watervlekken en glanzende slijtplekken van pannen verwijdert u met het door de fabrikant aanbevolen speciale reinigingsmiddel (bijv. Cerafix, Stahlfix). Aangekoekte en vastgebrande resten (suiker, zout of sulkerhoudende voedselresten) verwijdert u, in nog hete toestand, met een glasschraper. Raadpleeg hiervoor ook de handleiding van de fabrikant van het apparaat!

Grepen:

Gebruik geen oplosmiddelhoudende en aluminium beschadigende substanties en geen schoonmaakazijn omdat deze tot vlekken kunnen leiden die niet meer te verwijderen zijn.

F Conseils d'entretien

Revêtements en plastique :

Les revêtements / fronts en plastique peuvent être entretenus au moyen d'un produit de nettoyage ménager courant. L'idéal est d'utiliser un chiffon doux, de l'eau tiède et un peu de produit pour la vaisselle. N'utilisez pas de produit de polissage ou d'éponges dures ! Éliminez les taches tenaces, telles que les projections de graisse et résidus de vernis ou de colle, au moyen d'un produit de nettoyage pour le plastique courant. Avant la première utilisation de ce produit, il est recommandé de tester celui-ci à un endroit dissimulé !

Fronts brillants : Ne nettoyez jamais ces fronts à sec !

L'utilisation de produits de nettoyage abrasifs (chiffons en microfibras, éponges abrasives, etc.) peut entraîner la formation accrue de rayures et ne peuvent justifier aucune réclamation. L'idéal est donc d'utiliser un chiffon non-pelucheux ou une peau de chamois humide.

Eviens encastrés et tables de cuisson :

Les éviens encastrés et tables de cuisson, ainsi que tous les éléments en acier inoxydable n'étant pas cités ici doivent être entretenus avec une éponge ou une peau de chamois, imprégnées de produit vaisselle ou d'un produit spécifique (détergent inox, polish métal). Les éviens encastrés fabriqués dans d'autres matériaux, tels que de la porcelaine, du plastique, de la céramique acrylique, ainsi que les éviens en acier inoxydable doivent être nettoyés au moyen de produit vaisselle ou détergent doux. Respectez également les consignes d'entretien spécifiques du fabricant !

Plaques vitrocéramiques :

Éliminez les taches tenaces, les taches de calcaire et d'eau, ainsi que les traces brillantes laissées par les casseroles au moyen du détergent spécial recommandé par le fabricant (par ex. Cerafix, Stahlfix). Éliminez les restes carbonisés (sucre, sel ou aliments sucrés) encore chauds au moyen d'un racloir. Respectez ici les instructions du fabricant de l'appareil !

Polignées :

N'utilisez pas de substances à base de solvant et détergent l'aluminium ou produits à base de vinaigre ; ceux-ci peuvent causer des taches indélébiles.

