

WF297932







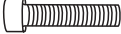

Installationsanleitung

Installation Instruction

Instruction d'installation

DE
Warnung
1 Die maximale Tragfähigkeit des Produkts beträgt 150 kg. Überladen vermeiden.
2 Kinder dürfen nicht auf Möbel klettern, da dies zu Kippen und schweren Verletzungen führen kann.
3 Um die Sicherheit zu gewährleisten, installieren Sie bitte gemäß den Anweisungen korrekt und holen Sie bei Bedarf professionelle Hilfe ein.
4 Stellen Sie Möbel nicht in der Nähe von Wärmequellen oder heißen Gegenständen auf, um Brandgefahr zu vermeiden.
5 Vermeiden Sie es, Möbel in feuchten Umgebungen zu platzieren, um Materialschäden zu vermeiden.
6 Überprüfen Sie regelmäßig alle Verbindungsstücke und Befestigungen, um sicherzustellen, dass sie fest sitzen und unerwartete Unfälle zu verhindern.
7 Reinigen Sie Möbel mit einem feuchten Tuch oder Alkohol, vermeiden Sie die Verwendung von Reinigungsmitteln, die ätzende Chemikalien enthalten.
UK
Warning
1 The maximum load capacity of the product is 150 kg. Do not overload.
2 Children should not climb on furniture, as this may cause tipping and serious injuries.
3 To ensure safety, please install according to the instructions correctly, and seek professional assistance if necessary.
4 Do not place furniture near heat sources or hot items to avoid the risk of fire.
5 Do not place furniture in damp environments to prevent material damage.
6 Regularly check all connections and fasteners to ensure they are secure to prevent accidents.
7 Clean furniture with a damp cloth or alcohol, avoid using cleaning agents containing corrosive chemicals.
FR
Avertissement
1 La charge maximale du produit est de 150 kg. Ne pas surcharger.
2 Les enfants ne doivent pas grimper sur les meubles, car cela peut entraîner un renversement et des blessures graves.
3 Pour assurer la sécurité, veuillez installer correctement selon les instructions et demander une assistance professionnelle si nécessaire.
4 Ne placez pas les meubles près de sources de chaleur ou d'objets chauds pour éviter les risques d'incendie.
5 Évitez de placer les meubles dans des environnements humides pour éviter les dommages aux matériaux.
6 Vérifiez régulièrement toutes les connexions et les fixations pour vous assurer qu'elles sont sécurisées et prévenir les accidents.
7 Nettoyez les meubles avec un chiffon humide ou de l'alcool, évitez d'utiliser des agents de nettoyage contenant des produits chimiques corrosifs.
IT
Avviso
1 La capacità massima del prodotto è di 150 kg. Non sovraccaricare.
2 I bambini non devono arrampicarsi sui mobili, poiché ciò potrebbe causare il ribaltamento e gravi lesioni.
3 Per garantire la sicurezza, installare correttamente secondo le istruzioni e chiedere assistenza professionale se necessario.
4 Non posizionare i mobili vicino a fonti di calore o oggetti caldi per evitare il rischio di incendio.
5 Evitare di posizionare i mobili in ambienti umidi per evitare danni ai materiali.
6 Controllare regolarmente tutte le connessioni e i fissaggi per assicurarsi che siano sicuri e prevenire gli incidenti.
7 Pulire i mobili con un panno umido o alcool, evitare l'uso di agenti di pulizia contenenti sostanze chimiche corrosive.
ES
Aviso
1 La capacidad máxima de carga del producto es de 150 kg. No sobrecargar.
2 Los niños no deben trepar sobre los muebles, ya que esto puede causar que se vuelquen y provocar lesiones graves.
3 Para garantizar la seguridad, instale correctamente según las instrucciones y busque asistencia profesional si es necesario.
4 No coloque los muebles cerca de fuentes de calor o objetos calientes para evitar el riesgo de incendio.
5 Evite colocar los muebles en entornos húmedos para evitar daños en los materiales.
6 Revise regularmente todas las conexiones y sujeciones para asegurarse de que estén seguras y prevenir accidentes.
7 Limpie los muebles con un paño húmedo o alcohol, evite el uso de agentes de limpieza que contengan productos químicos corrosivos.

ELEMENTS/PARTS	Ax8  M8×55mm	Bx1  M8×60mm	Cx4  M8×65mm
	Dx1 	Ex13 	Fx13 

Bitte beachten Sie, dass die Formen der Schrauben A und B und C ähnlich sind. Bitte installieren Sie entsprechend der Anleitung und unterscheiden Sie sie!

Please note that the shapes of screws A and B and C are similar. Please install according to the instructions and distinguish them!

Notez que les vis A et B et C ont des formes similaires. Veuillez les installer en suivant les instructions pour les séparer!

1

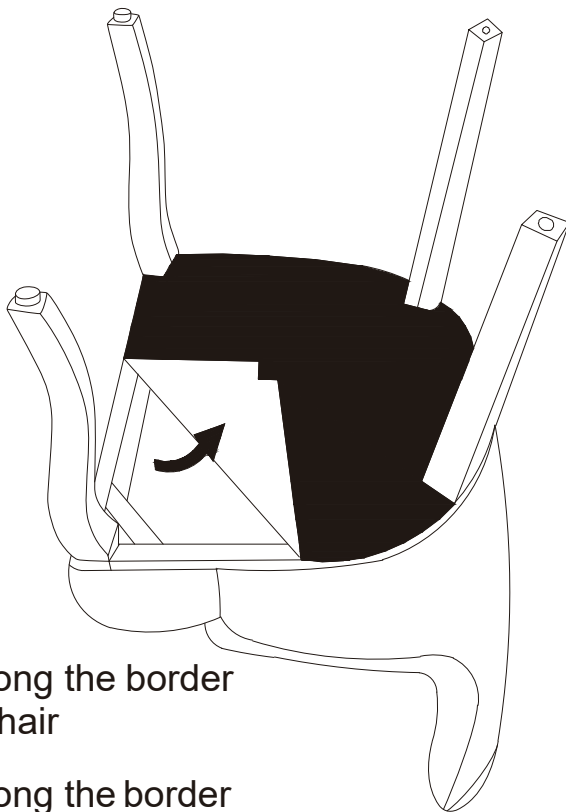

Tear along the border
of the chair

Tear along the border
of the chair

déchirer le long du bord
de la chaise.

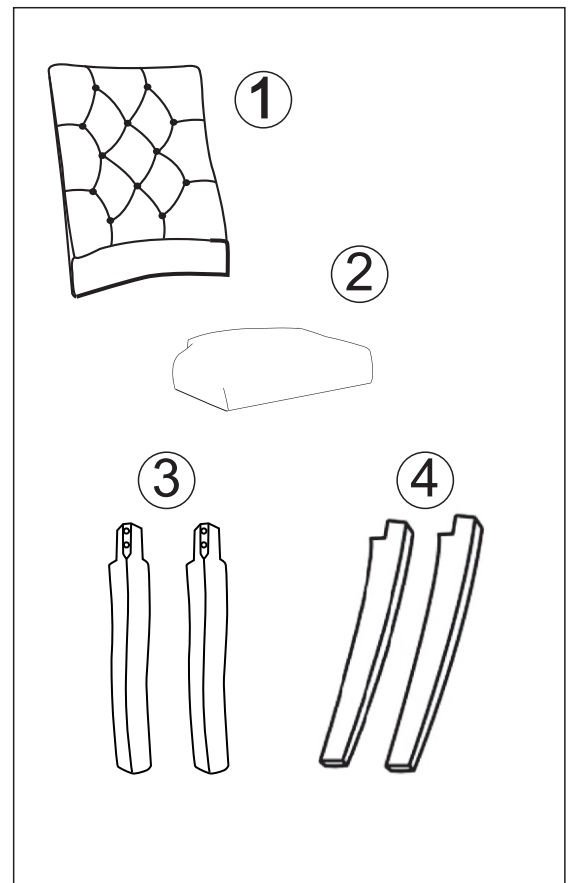

2



Vor dem Einbau die Schrauben in die Löcher stecken und festziehen, aber nicht bis 100%, 70% bis 80% anziehen reicht aus. Wenn alle vier Beine des Stuhls den Boden berühren können, ohne zu schütteln, ziehen Sie alle Schrauben auf 100%. Wenn Sie auf diese Probleme stoßen, z.B. wenn die Löcher nicht ausgerichtet werden können oder einige Teile nicht installiert werden können, überprüfen Sie bitte, ob die Schrauben korrekt verwendet werden und passen Sie die Dichtheit der Schrauben an.

Insérer la vis dans le trou avant la fin de l'assemblage, serrer la vis, mais ne pas serrer à 100%, 70% ~ 80% est correct. Enfin, si la chaise peut toucher le sol avec ses quatre pieds et ne tremble pas, serrez toutes les vis à 100%. Si vous rencontrez ces problèmes, par exemple si les trous ne sont pas alignés ou si certaines pièces ne peuvent pas être montées, vérifiez que les vis sont utilisées correctement et ajustez leur serrage.

Before installation, insert the screws into the holes and tighten them, but do not tighten them to 100%, 70% to 80% is sufficient. Finally, if all four legs of the chair can touch the ground without shaking, tighten all screws to 100%. If you encounter these issues, such as if the holes cannot be aligned or some parts cannot be installed, please check if the screws are used correctly and adjust the tightness of the screws.

3

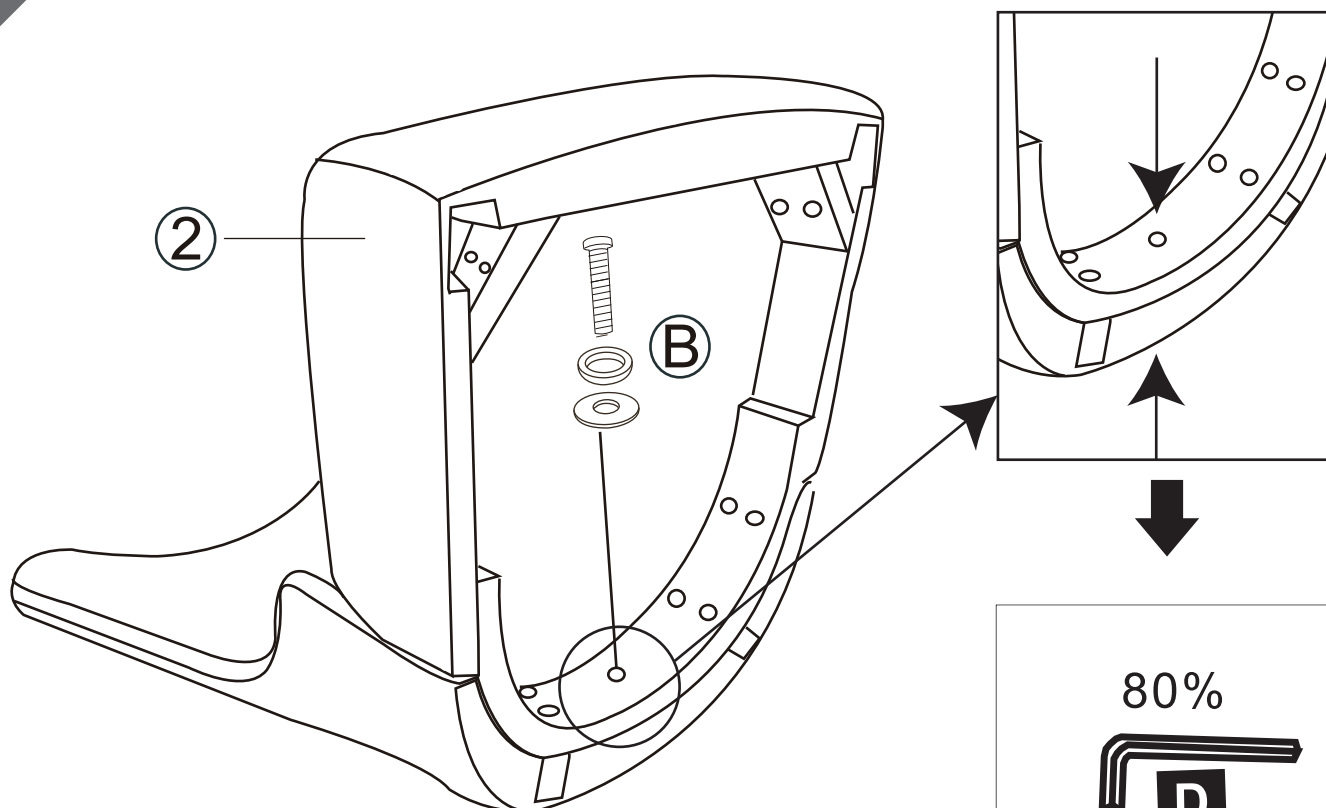

- * Bei der Montage stehen die Schrauben senkrecht zum Sitzkissenrahmen!
- * mit bolzen (B) Indiesem zug.
- * Muss man nicht alles befestigen, muss man nur um 80% abschrauben.

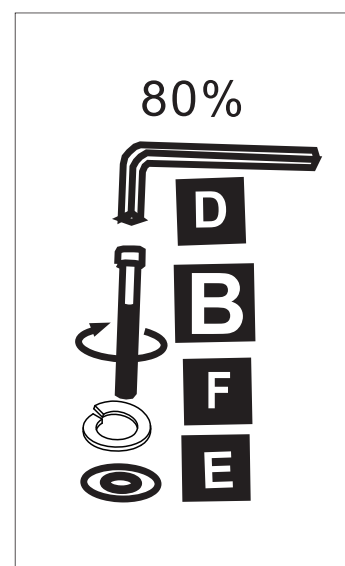



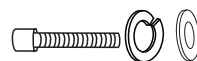

- * When installing, the screws are perpendicular to the seat cushion frame!
- * Use screws (B) in this step.
- * Do not fully tighten only to 80% at this stage!



M8×60 

- * Lors de l'installation, les vis et le cadre de coussin sont verticaux!
- * Insérer vis (B) dans l'espace.
- * Il n'est pas nécessaire de tout fixer, il suffit de dévisser de 80%.

B	 M8×60mm	1 PCS
E		1 PCS
D		1 PCS
F		1 PCS

4

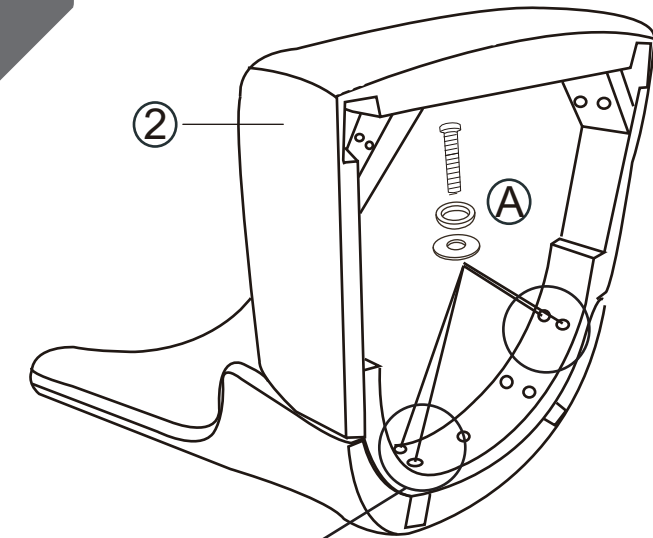



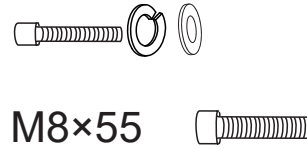
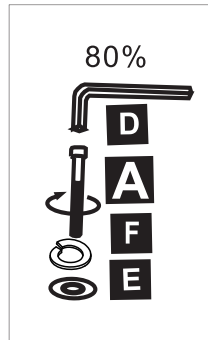
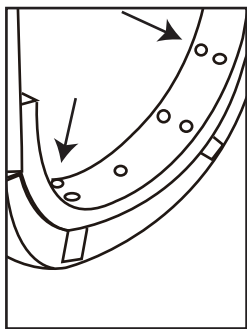

* mit bolzen (A) Indiesem zug.
Muss man nicht alles befestigen,
muss man nur um 80% abschrauben.

* Use screws (A) in this step.
* Donot fully tighten only to 80% at this stage!

* Insérer vis (A) dans l'espace.
* Il n'est pas nécessaire de tout
fixer, il suffit de dévisser de 80%.



A		4 PCS
	M8x55mm	
E		4 PCS
D		1 PCS
F		4 PCS

5

M8x65 

M8x50 

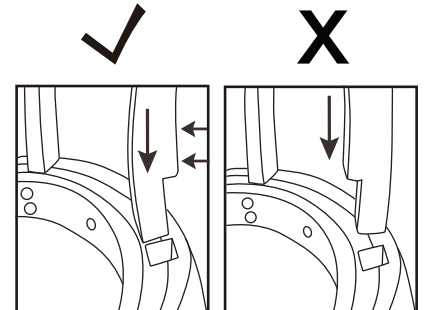
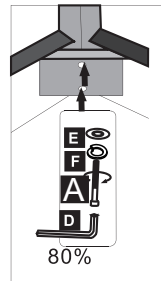
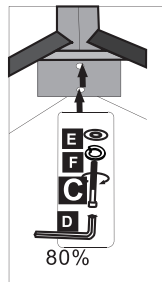
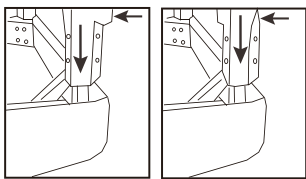

M8x60 

M8x55 

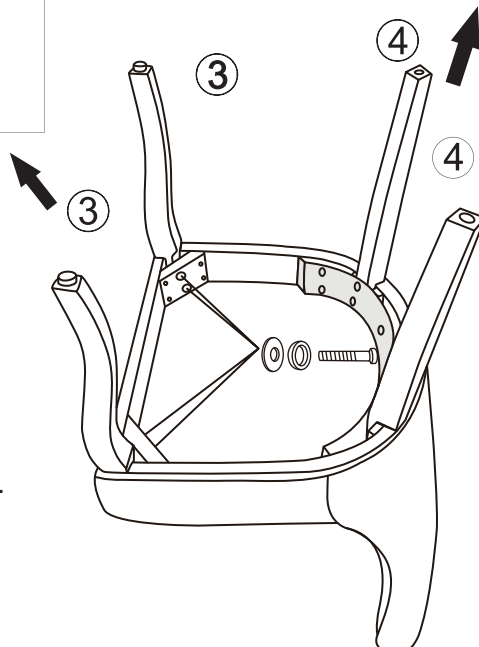

* Use screws (A/C) in this step.





* Donot fully tighten only to 80% at this s

* mit bolzen (A/C) Indiesem zug.

* Muss man nicht alles befestigen,
muss man nur um 80% abschrauben.

* Insérer vis (A/C) dans l'espace.

* Il n'est pas nécessaire de tout
fixer, il suffit de dévisser de 80%.

A		4 PCS
	M8x55mm	
C		4 PCS
	M8x65mm	
E		8 PCS
D		1 PCS
F		8 PCS

Einige Tage nach der Erstmontage kann das Produkt sich an die neue Umgebung gewöhnen. Bitte stellen Sie sicher, dass alle Schrauben noch 100% fest angezogen sind.

Somedays after initial assembly the product can get used to the new environment. Please make sure that all screws are still 100% tightened.

Quelques jours après le premier montage le produit peut s'adapter à l'environnement habituel à son nouvel environnement. Veuillez consulter Assurez-vous que toutes les vis soient encore bien serrées à 100%.

ABC

