













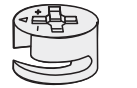

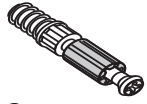

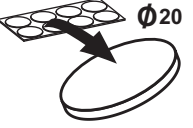

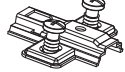
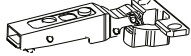

 4x B12L	 4x B12R	 16x W12	 32x D01	 8x W51	 8x T02	 8x T12	 16x T01	 16x D02	 4x C02a
 2x Z02Z04	 2x Z21	 2x Z22	 8x E01	 12x R01	 10x BZN	 18x W03	 16x W02	 20x W30	 10x G01
 2x F01	 2x F11	 2x F13	 4x W07	 4x P05L	 4x P05R	 6x S17	 6x U29	 1x K01	



0 10 20 30 40 50 60 70 80 90 100 110 120 130 140 150 160 170 180 190 200

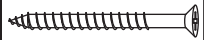

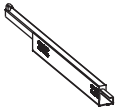
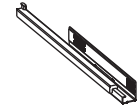
NR	DIM	QTE	COLLI
1	838x450x15	1	1/2
2	590x206x15	4	1/2
3	845x362x15	1	1/2
4	845x362x15	1	1/2
5	860x598x2	1	1/2
6	860x443x2	2	1/2
7	838x450x15	1	1/2
8	1500x380x22	1	2/2
9	554x300x2	4	2/2
10	543x120x12	4	2/2
11	300x120x12	4	2/2
12	300x120x12	4	2/2
13	845x343x15	1	2/2
14	845x343x15	1	2/2
15	426,5x340x15	2	2/2
16	1500x380x22	1	2/2

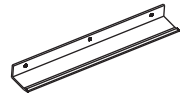
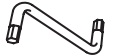
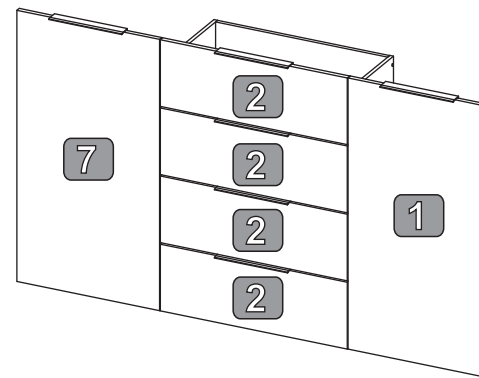
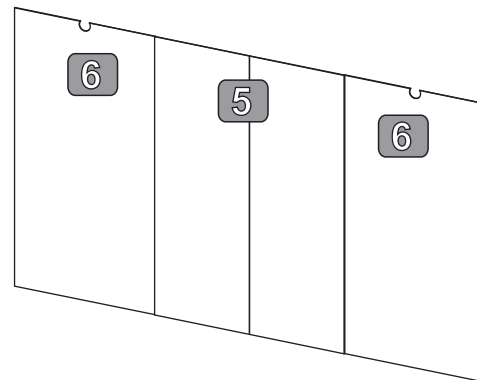
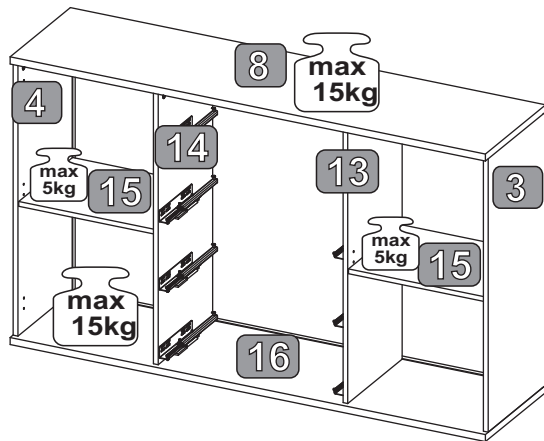
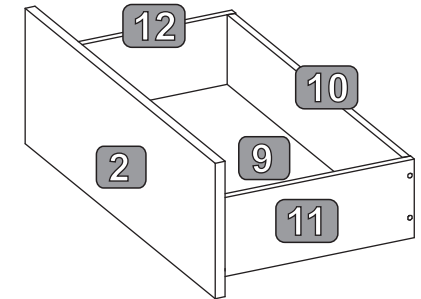
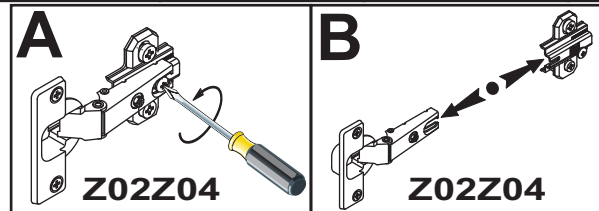
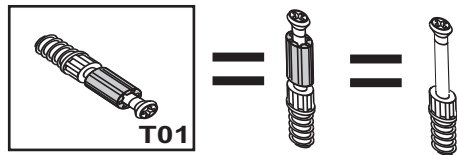
1

- 2x Z21
- 2x Z02Z04
- 8x 8x28 D01
- 4x 15x12 T02

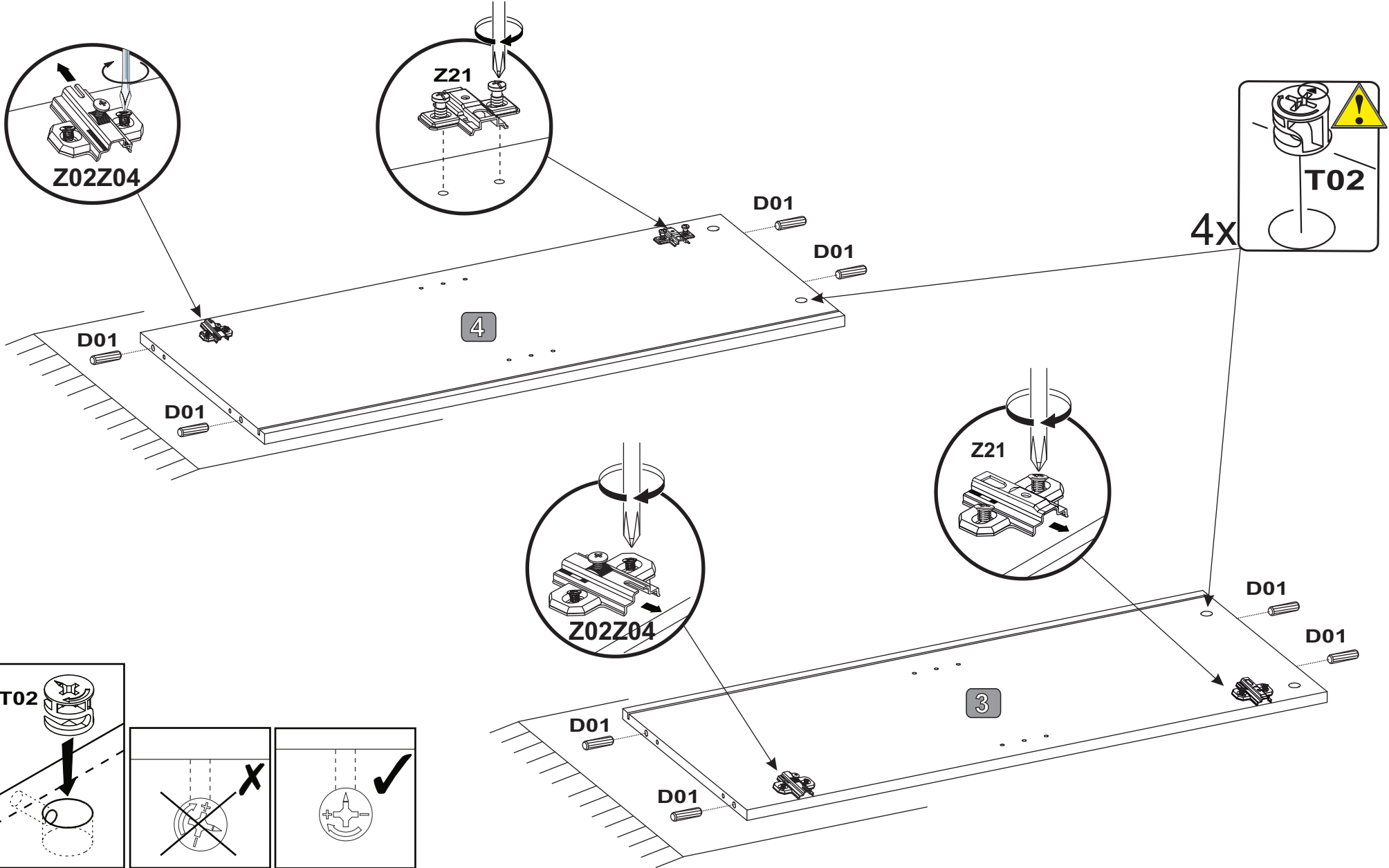
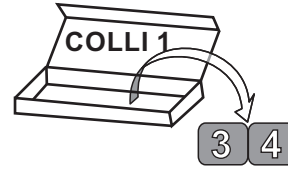

2

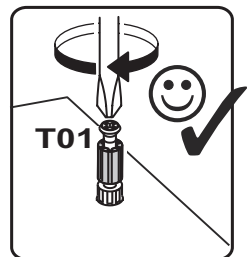
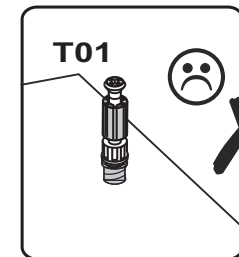
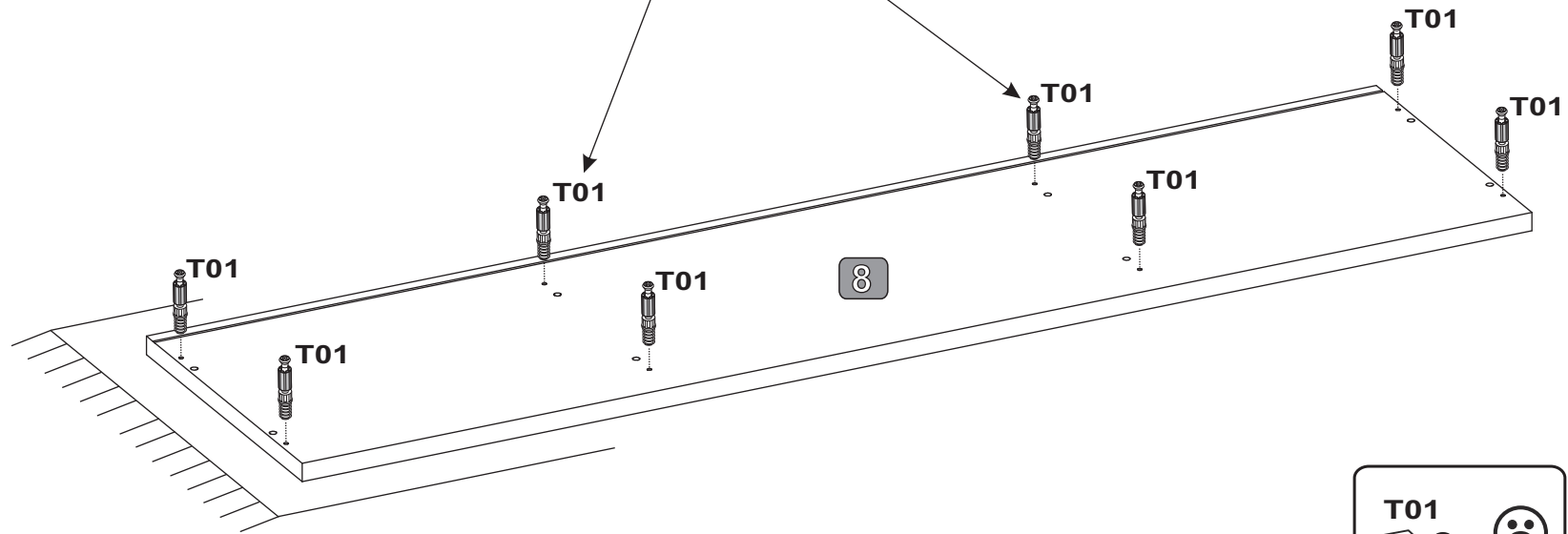
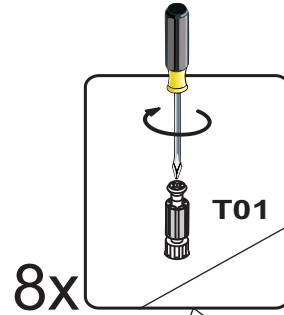
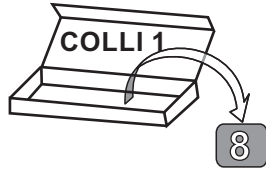
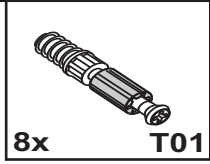

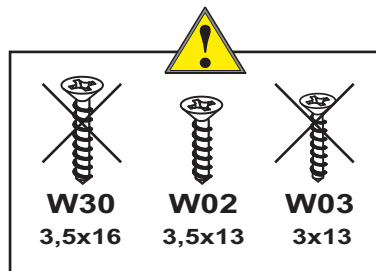
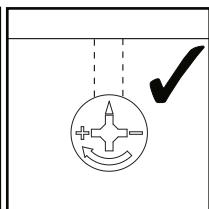
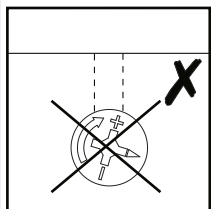
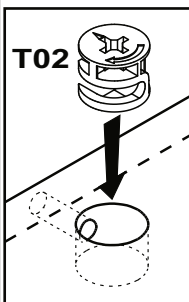
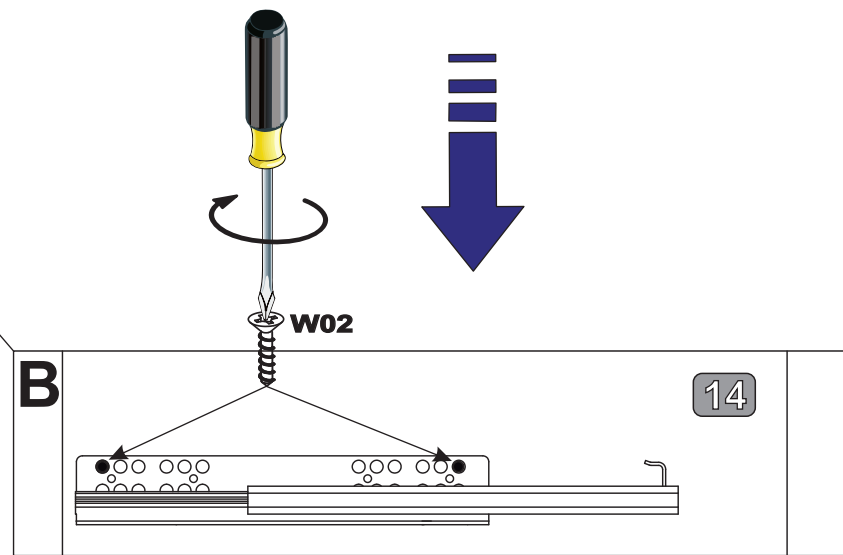
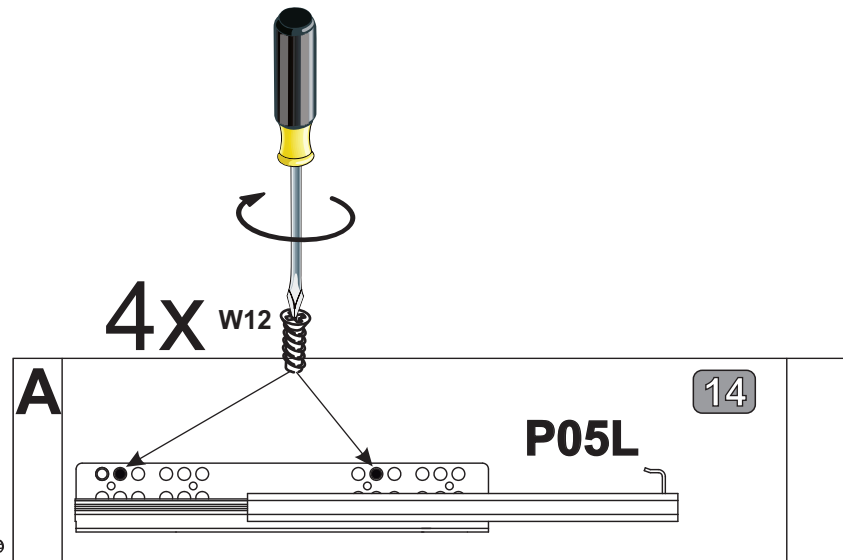
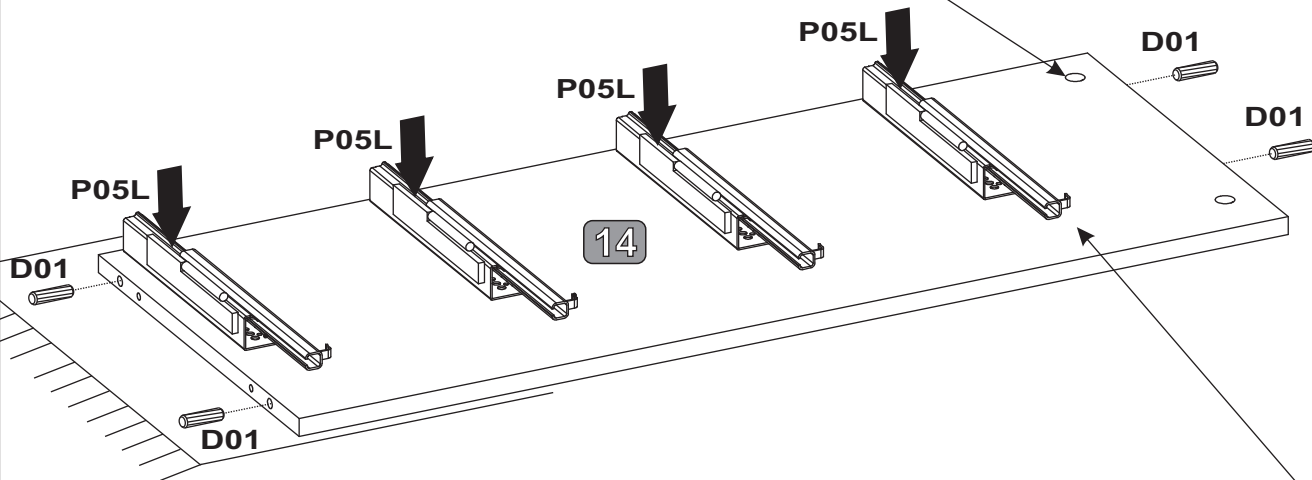
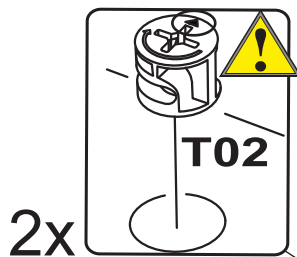
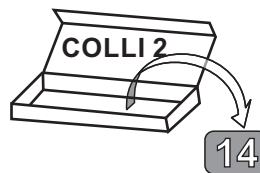

3

- 8x28 D01 4x
- 15x12 T02 2x
- P05L 4x
- 6x11 W12 8x
- 3,5x13 W02 8x

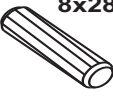
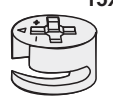
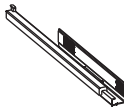

4

 8x28 4x D01	 15x12 2x T02	 4x P05R	 6x11 8x W12	 3,5x13 8x W02
---	--	--	---	---

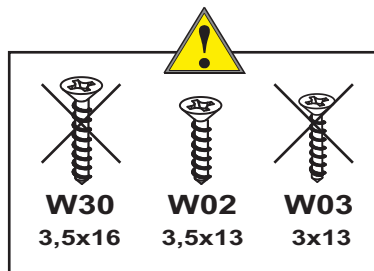
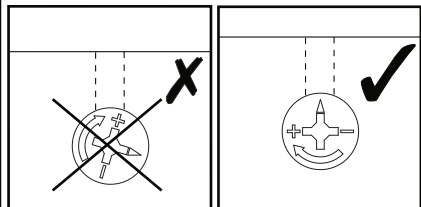
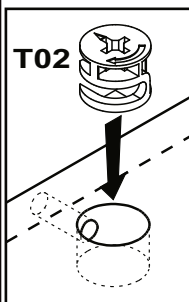
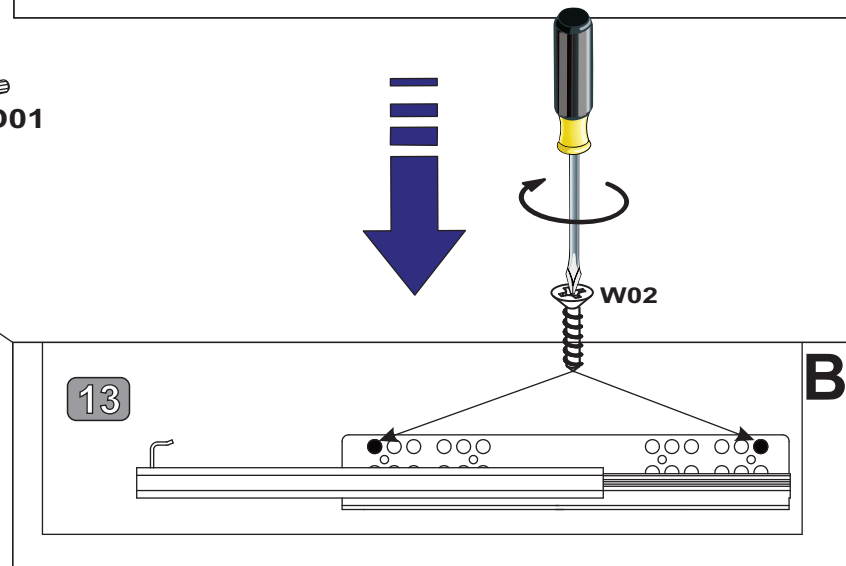
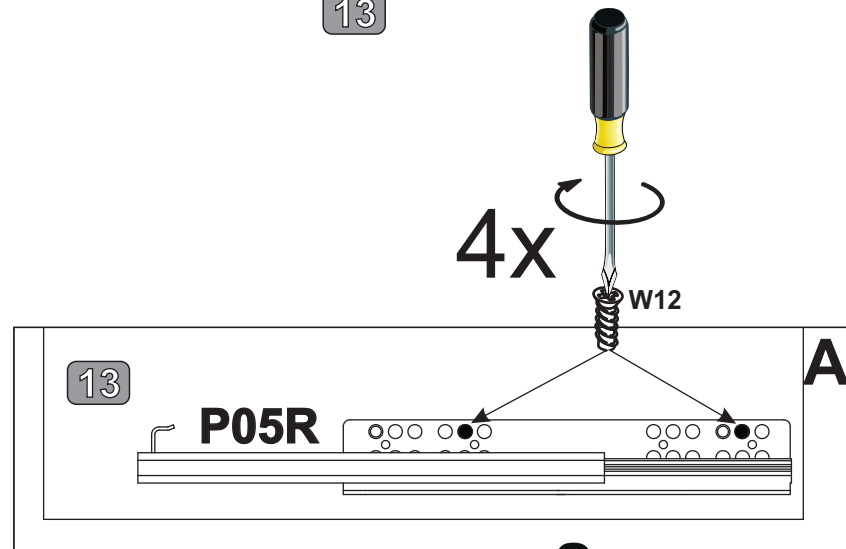
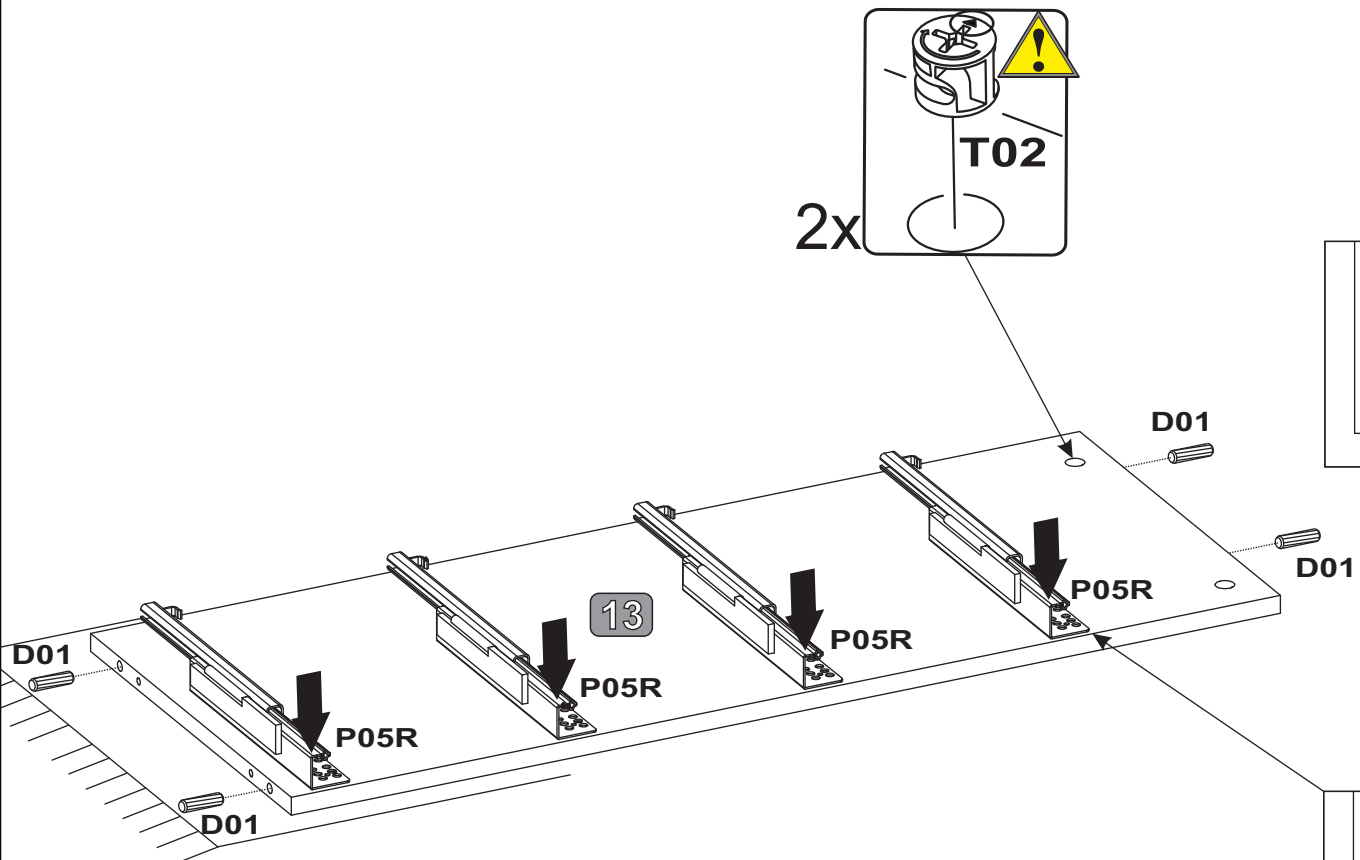
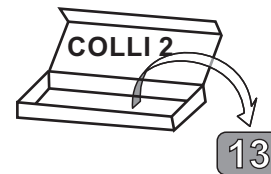

5

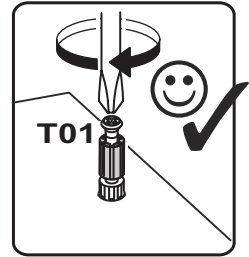
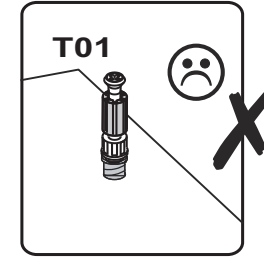
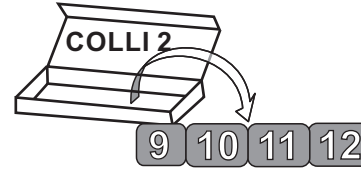
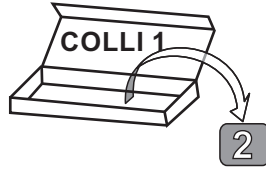
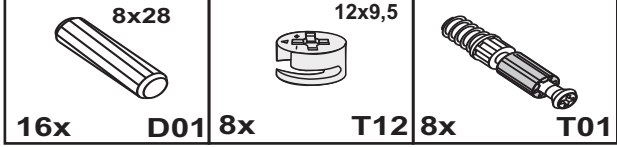

[4x]

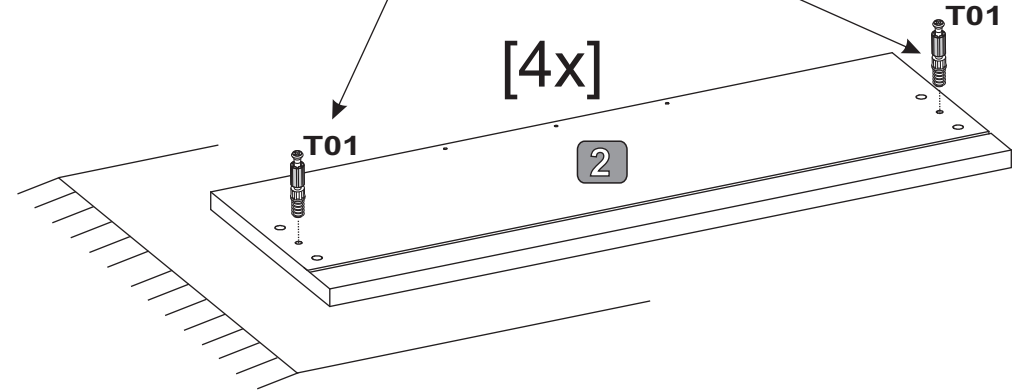
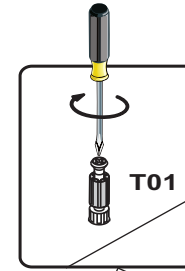
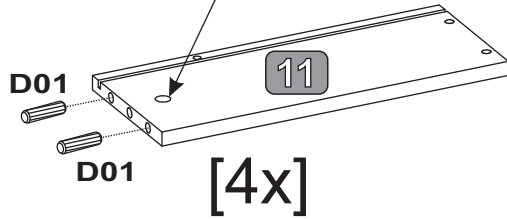
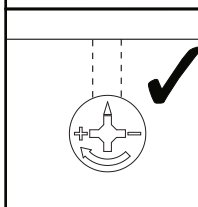
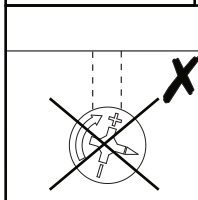
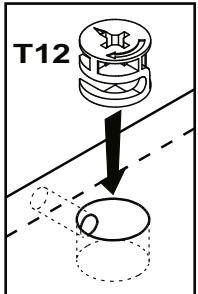
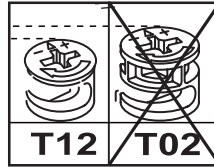
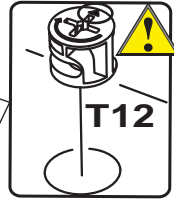
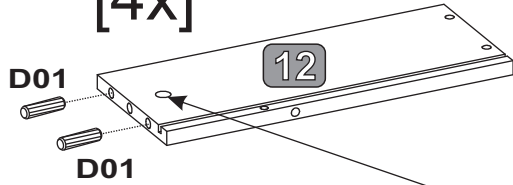

6

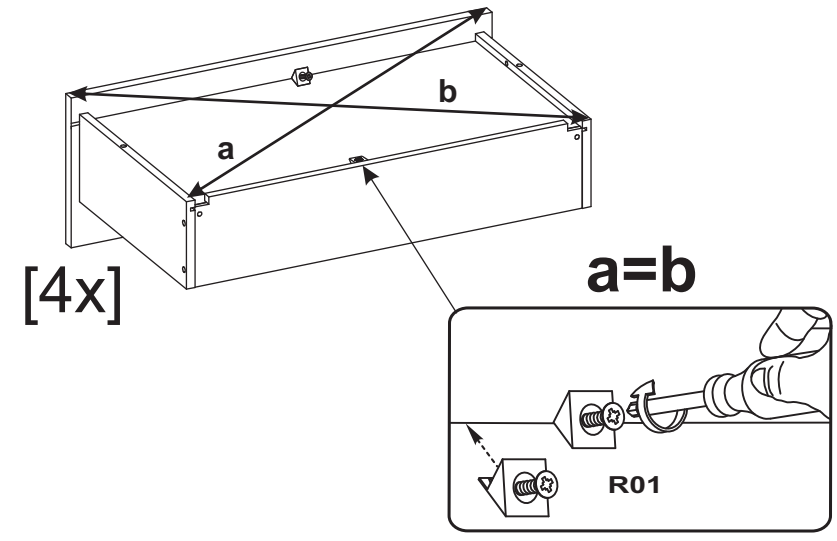
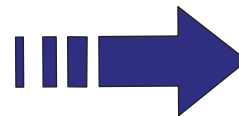
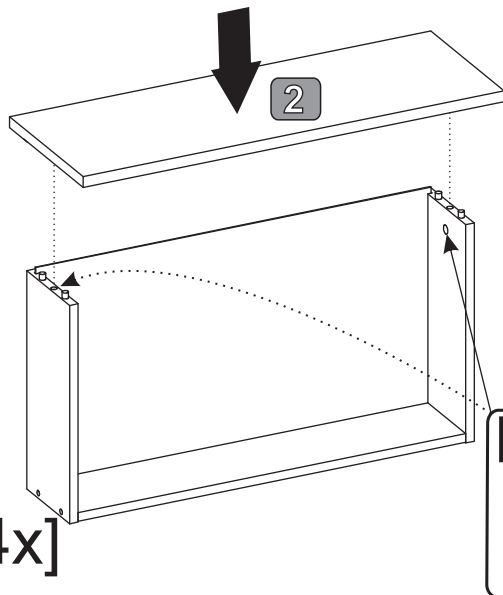
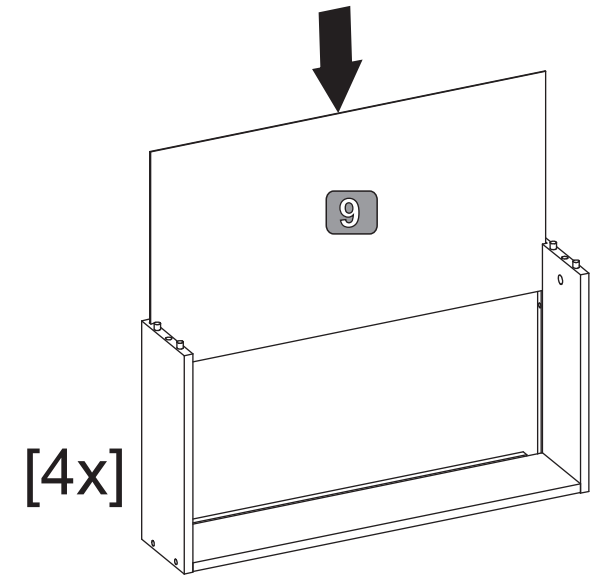
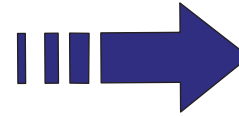
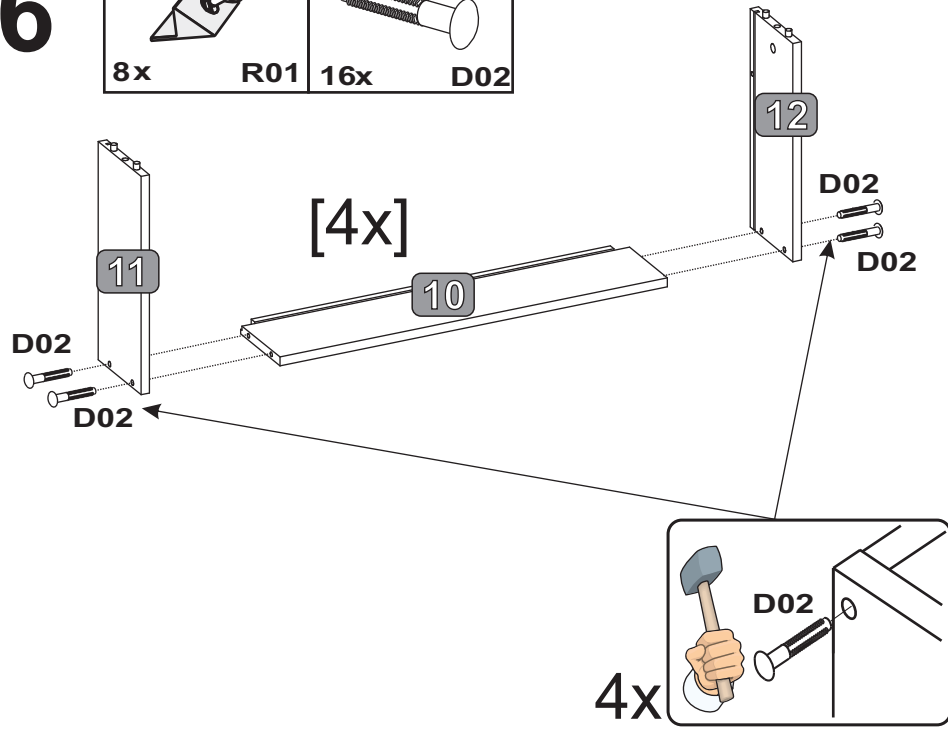
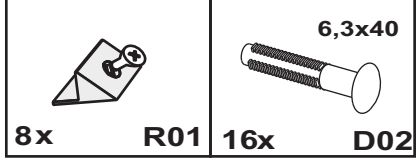

7

7x50

8x

W51

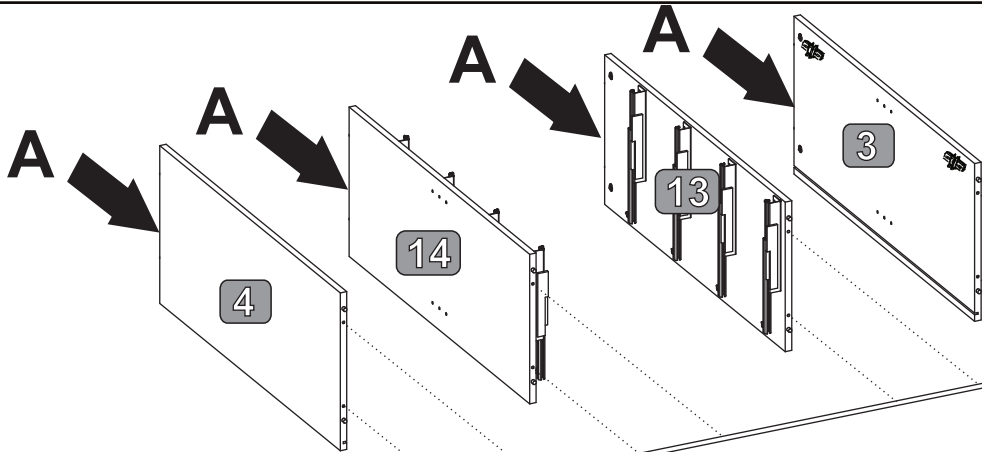
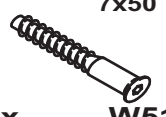

1x

K01

Z4



8x

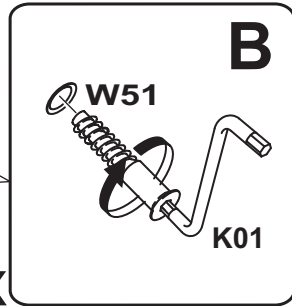

8

3,5x16

12x

W30

6x

S17

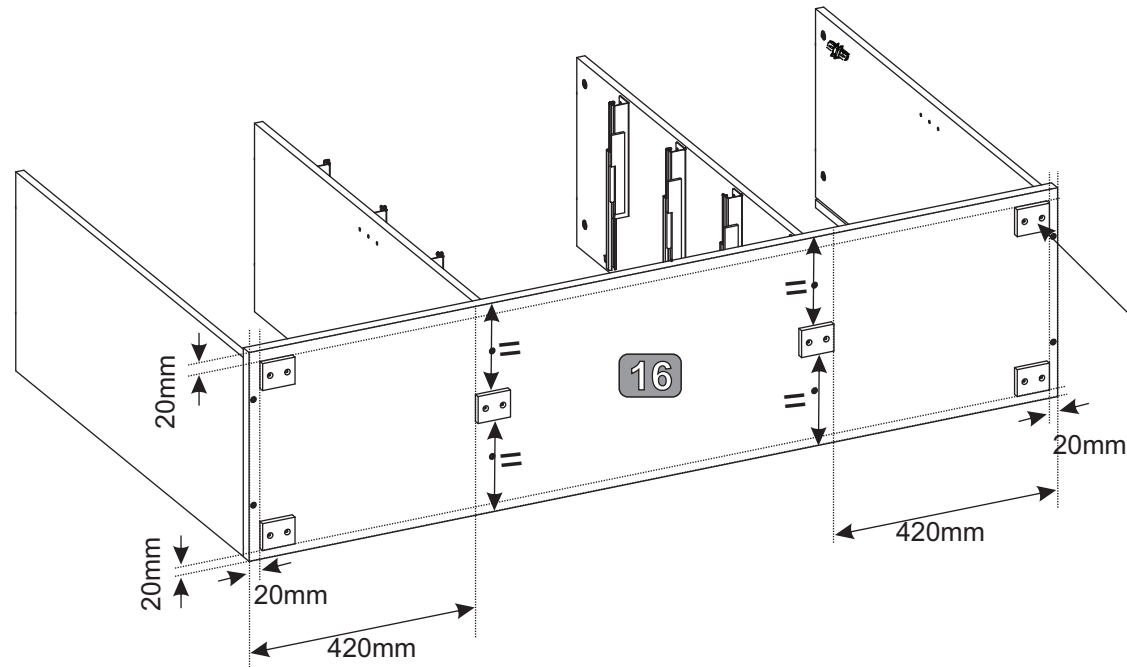

W30

3,5x16



W02

3,5x13



W03

3x13

6x

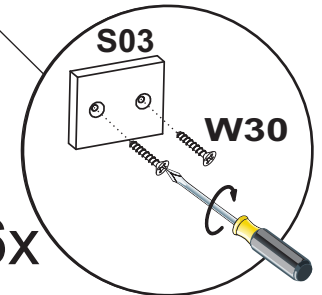

9

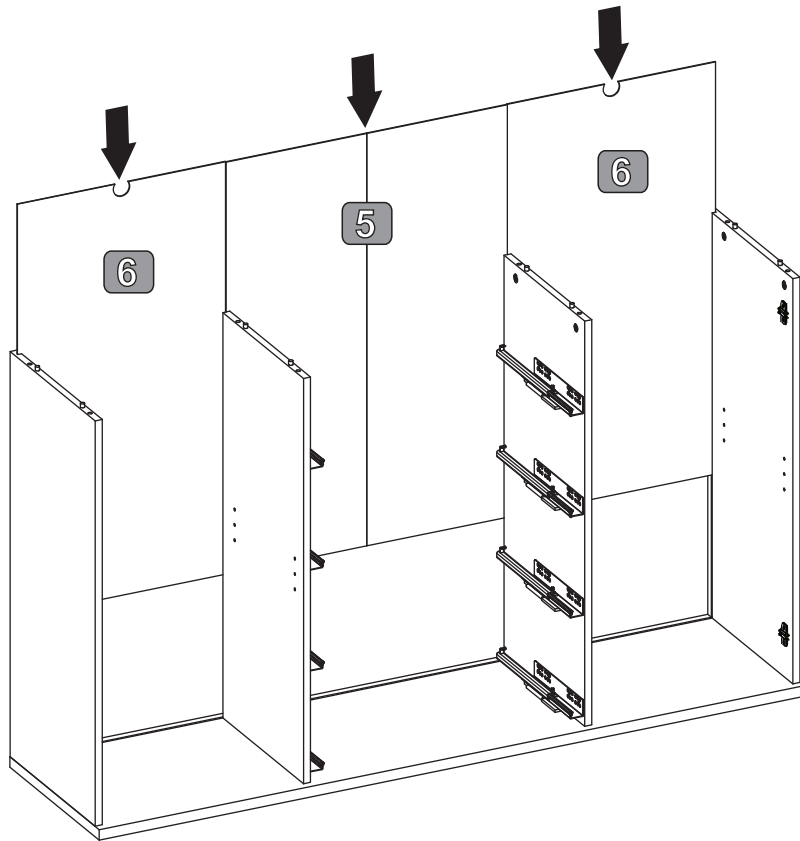
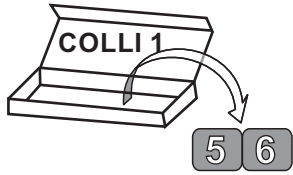

10

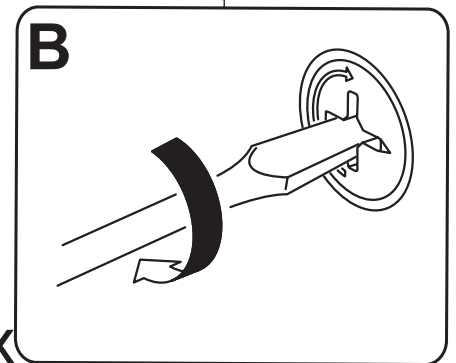
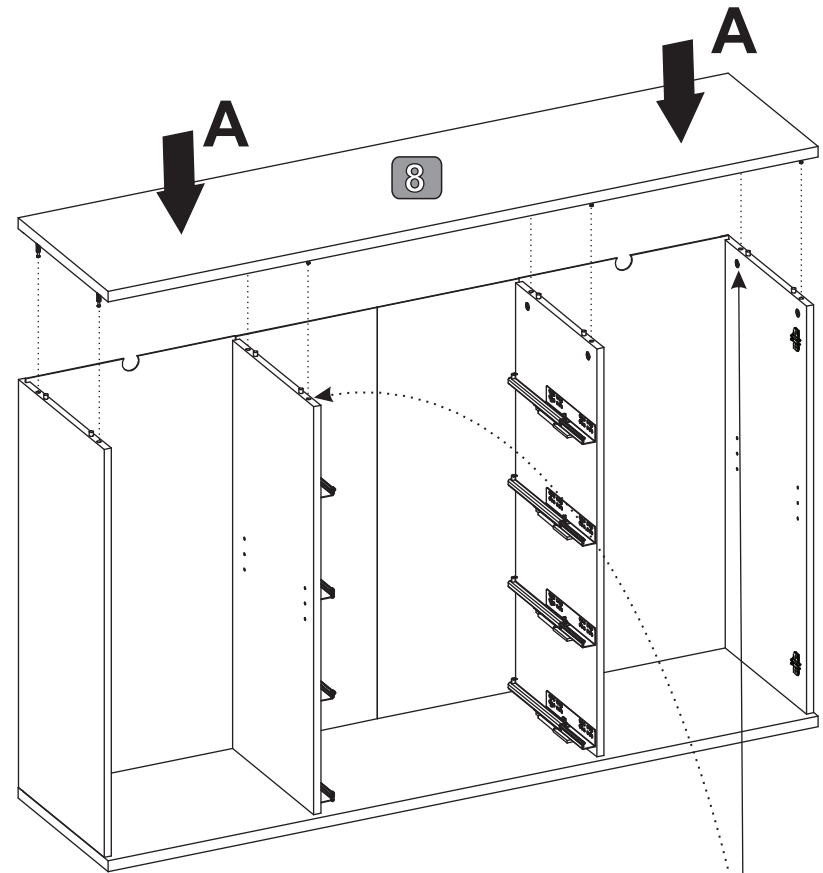

8x

11

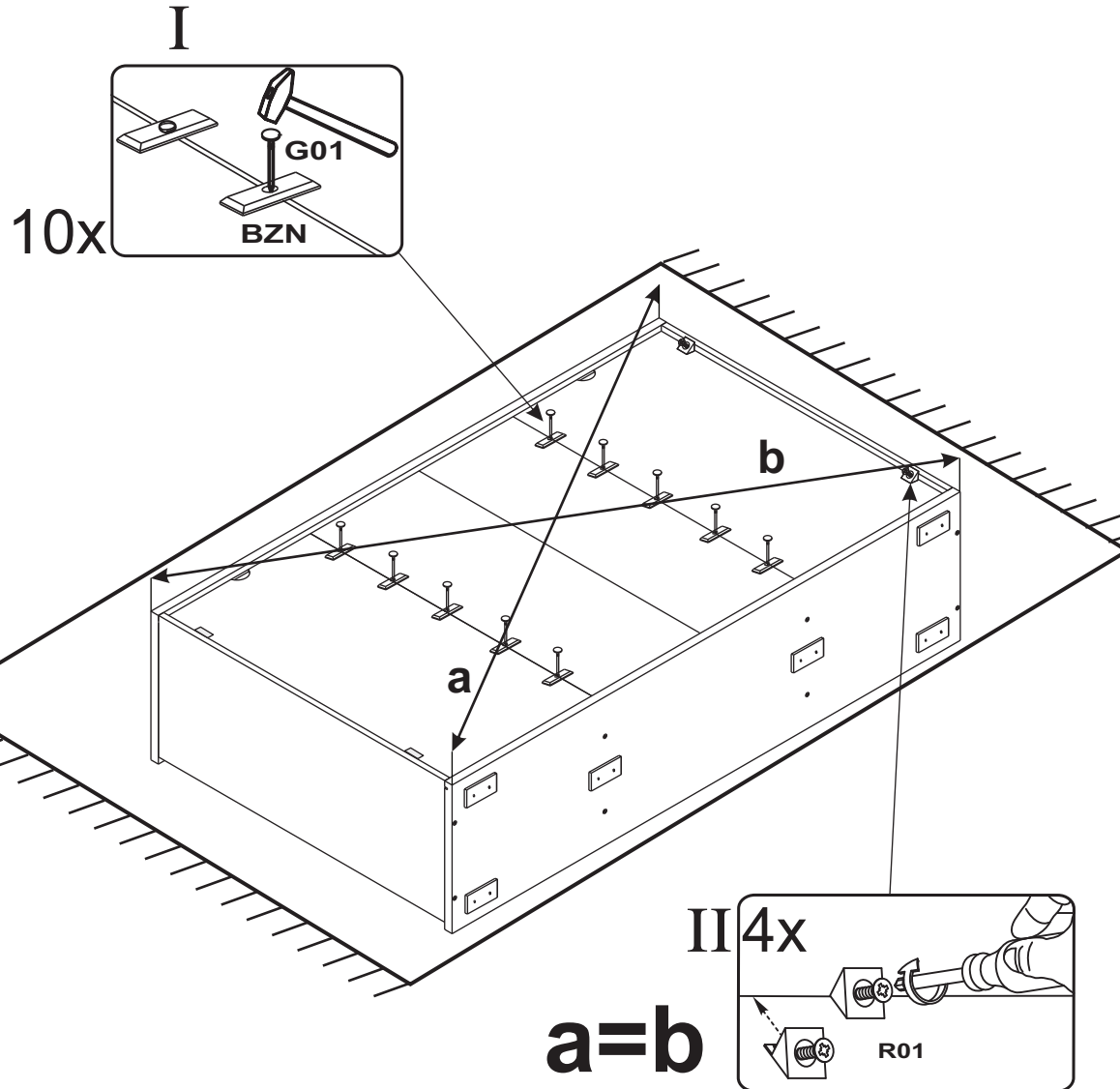
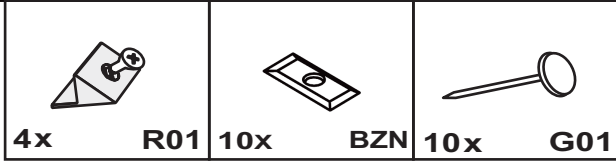

12

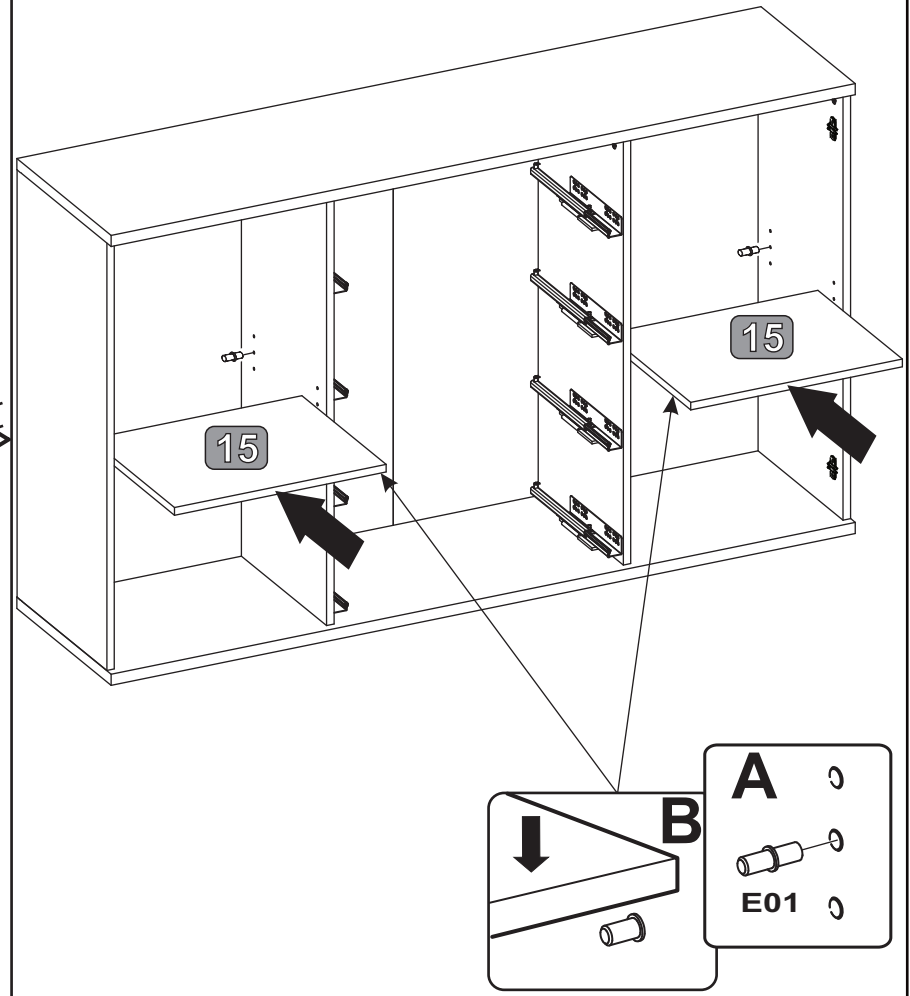
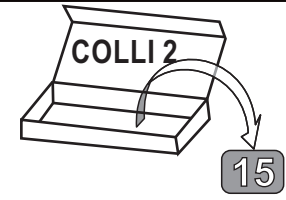
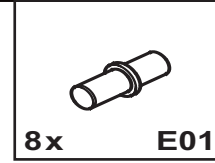

13

- 2x F01
- 2x F11
- 2x F13
- 4x13 W07

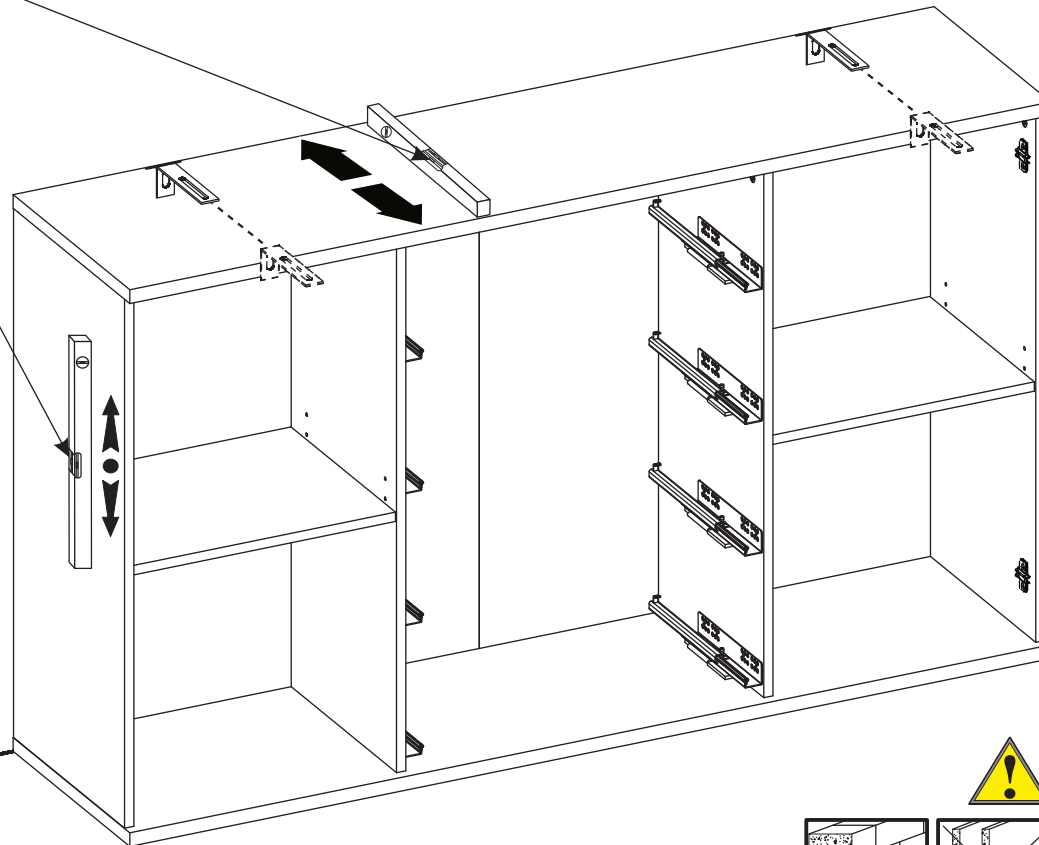
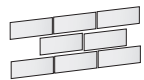
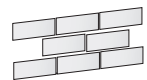
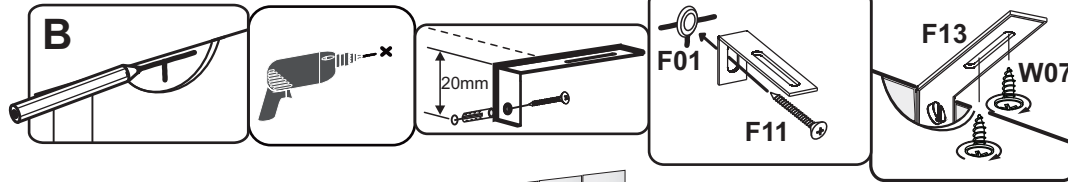
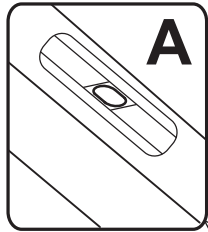

14

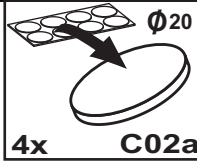

4x B12L



4x B12R



12x W03

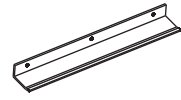

4x U29

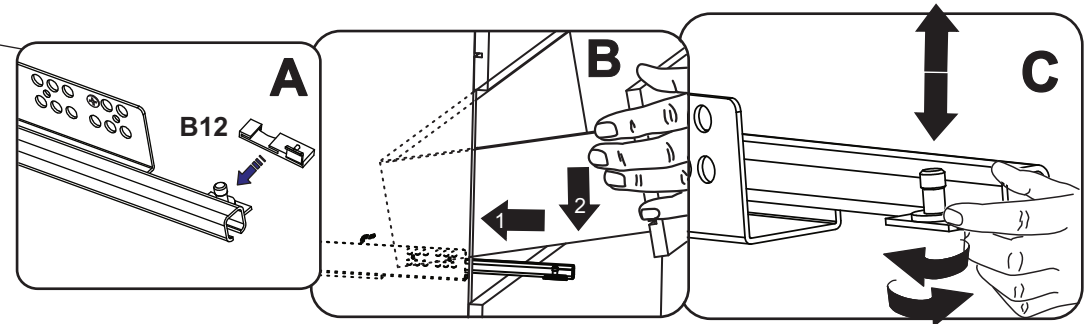
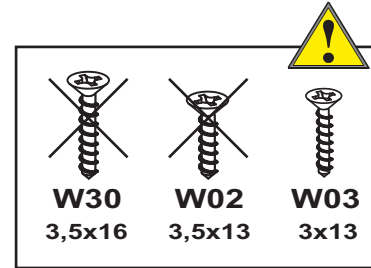
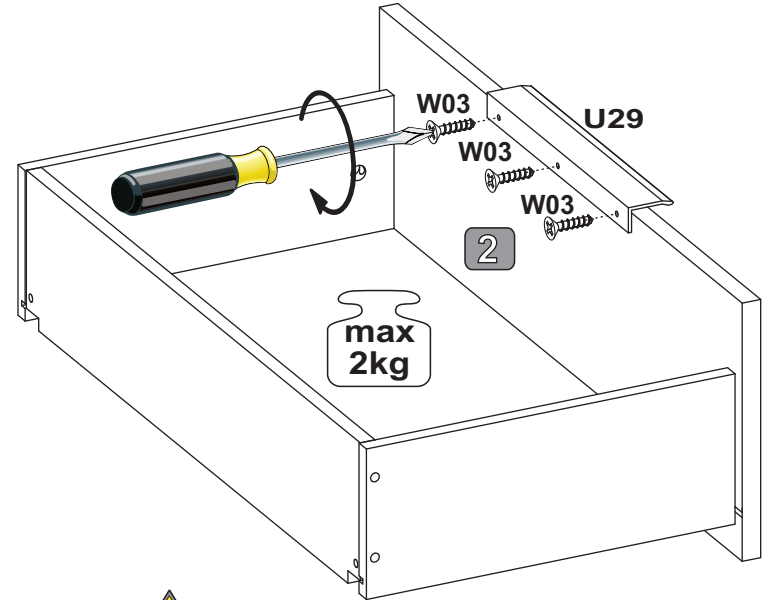
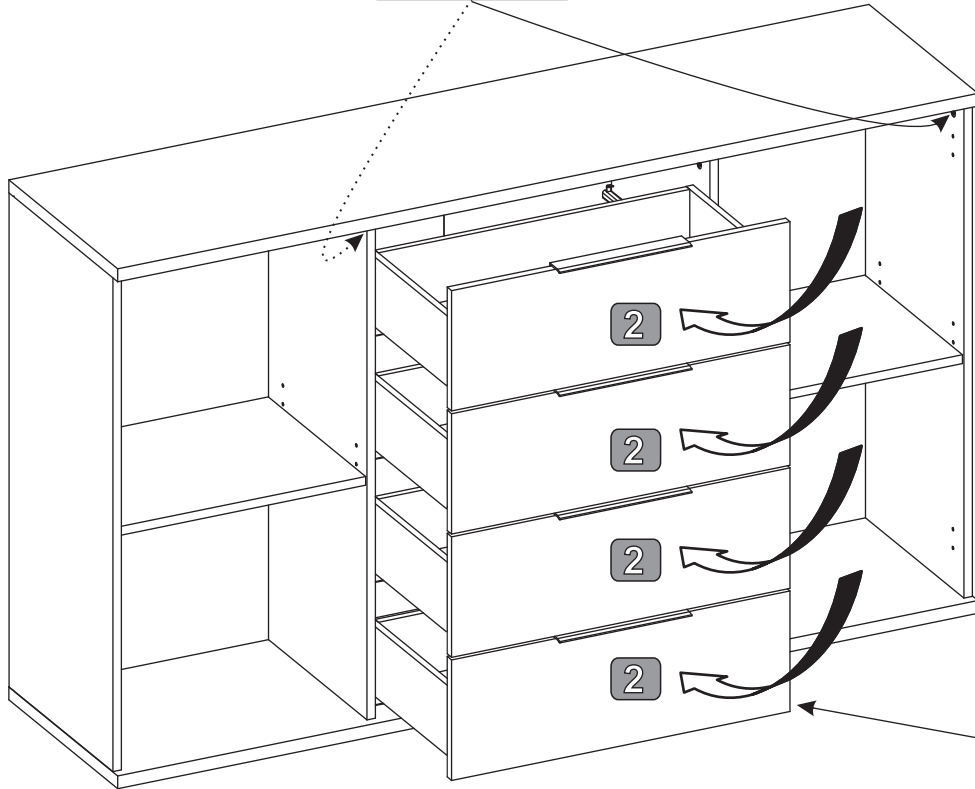
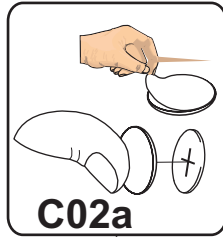

15

- 2x KR-0 Z22
- 8x 3,5x16 W30
- 2x $\Phi 26$ KR-0 Z02Z04

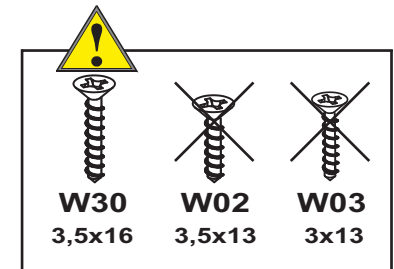
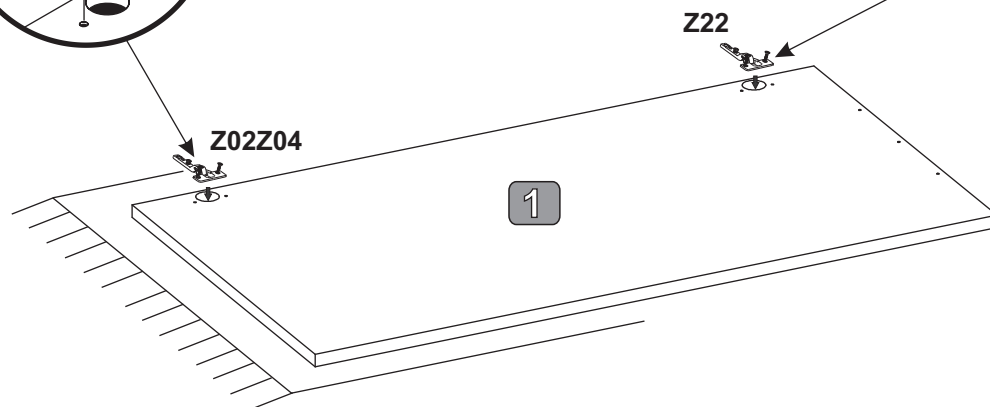
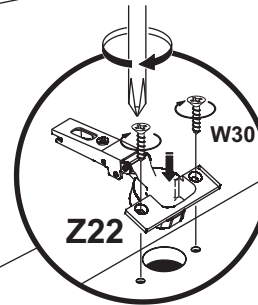
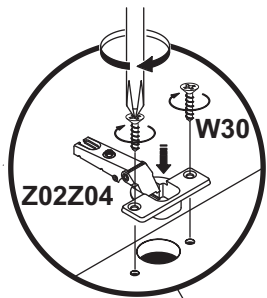
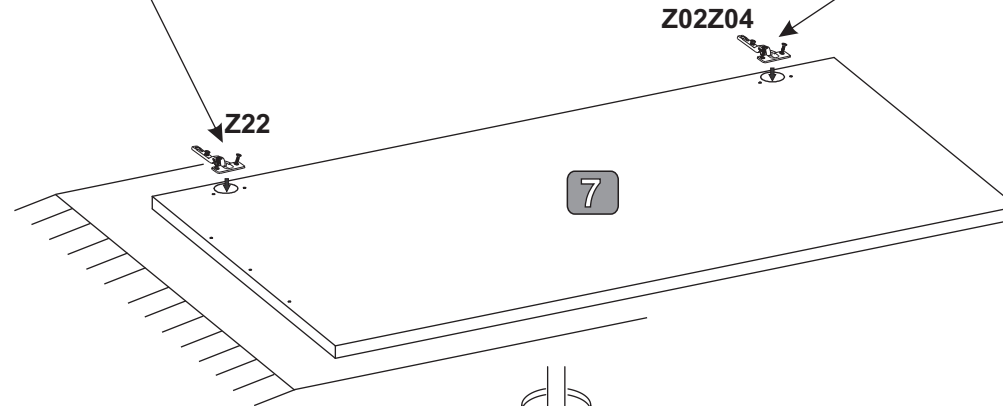
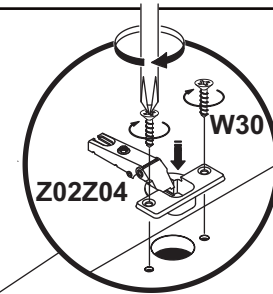
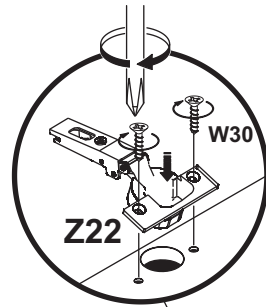
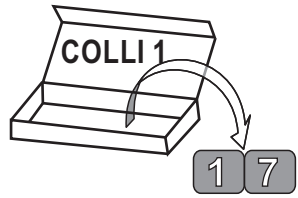

16

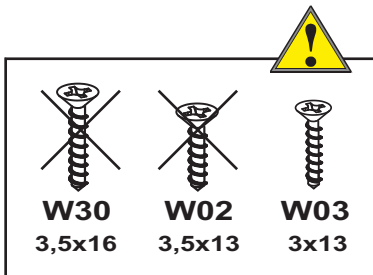
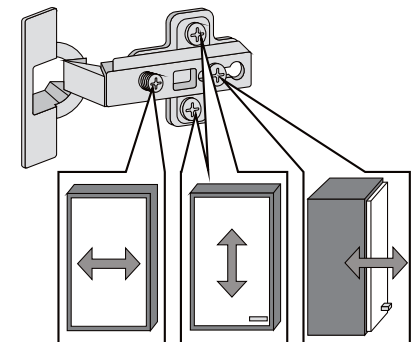
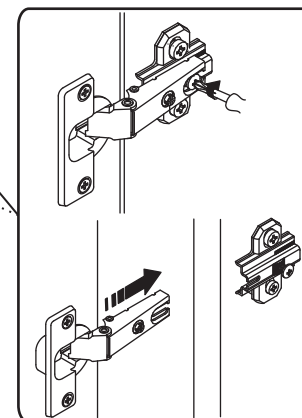
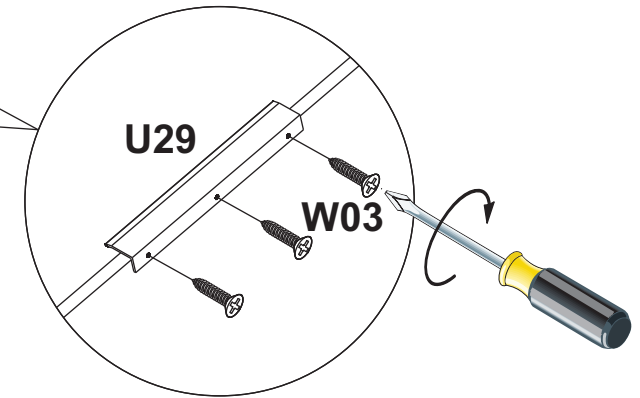
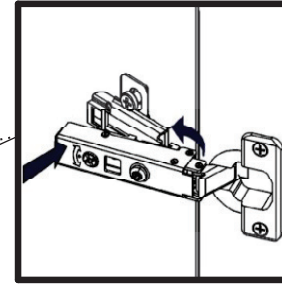
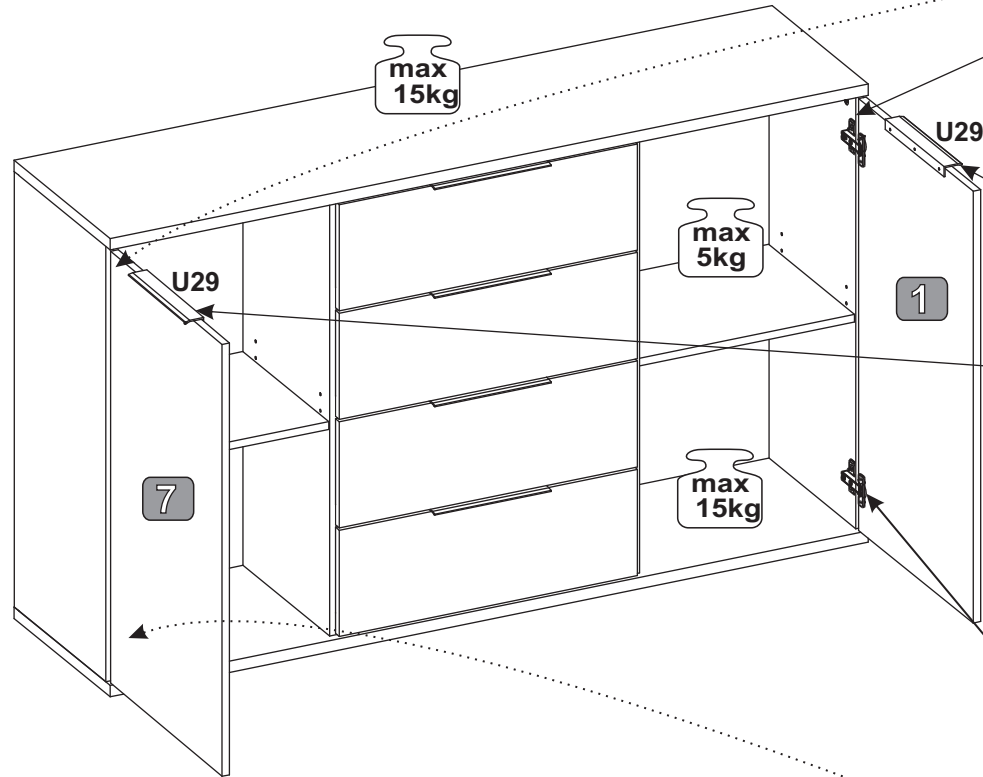
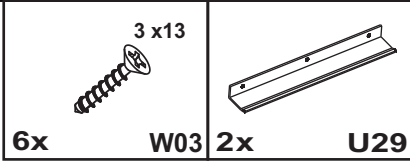

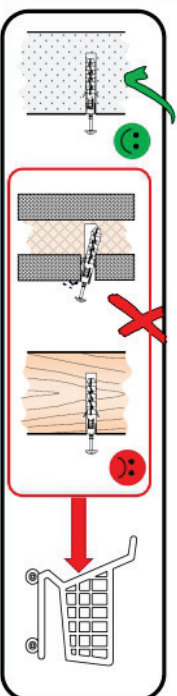
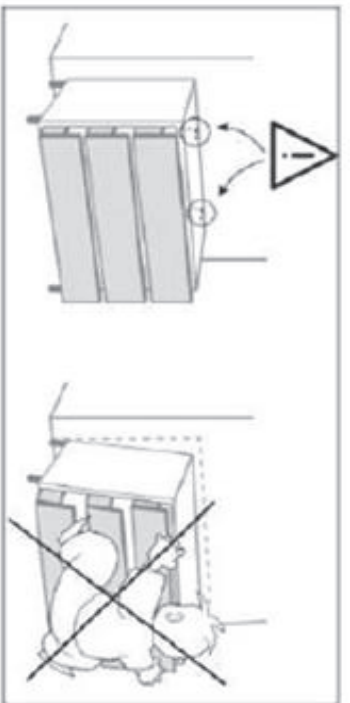

DE	Warnhinweis: Wenn der Ware Dübel und Schrauben beiliegen, sind sie ausschließlich zur Anwendung an Wänden aus massivem und einheitlichen Materialien bestimmt, um ein Umkippen zu verhindern. Vergewissern Sie sich vor dem Bohren, dass sich keine Gas-, Wasser-, oder Stromleitungen an der Bohrstelle befinden. Zur Befestigung an anderen Wänden müssen Spezialdübel verwendet werden. Erkundigen Sie sich im Handel nach den für die jeweilige Wandbeschaffenheit geeigneten Schrauben und oder Dübel. Für eine unsachgemäße Montage und dadurch entstandene Schäden übernimmt der Hersteller keine Haftung. Bitte alle Schrauben in regelmäßigen Abständen überprüfen und nachziehen.
FR	Avvertissement : Pour éviter le basculement accidentel du meuble, la fixation du meuble au mur rest obligatoire. Si des chevilles et des vis sont fournies avec l'article, elles sont exclusivement destinées à être utilisées sur des murs en matériaux massifs et homogènes pour éviter tout basculement. Avant de percer, assurez-vous qu'aucune conduite de gaz, d'eau ou d'électricité ne se trouve à l'endroit où vous percez. Pour la fixation sur d'autres murs, il faut utiliser des chevilles spéciales. Renseignez-vous sur les vis et les chevilles adaptées à chaque type de mur. Le fabricant décline toute responsabilité en cas de montage incorrect et de dommages qui en résulteraient. Veuillez vérifier et resserrer toutes les vis à intervalles réguliers. ATTENTION ! Les meubles contenant des panneaux à base de bois (panneaux de particules, panneaux de fibres, contreplaqué...) peuvent émettre des substances polluantes dans l'air intérieur. Il est ainsi recommandé, après l'installation du meuble dans son logement, d'aérer fréquemment la pièce concernée pendant au moins quatre semaines afin de réduire son exposition aux polluants émis par le meuble LED: Ce luminaire est un produit de décoration. Ce luminaire ne convient pas pour l'éclairage principal d'une pièce de la maison.
UK	Warning: If dowels and screws are included with the product, they are only intended for use on walls made of solid and uniform materials to prevent them from tipping over. Before drilling, make sure that there are no gas, water or electricity pipes at the drilling site. Special anchors must be used for fastening to other walls. Ask in the trade for the screws and or dowels suitable for the respective wall condition. The manufacturer accepts no liability for improper installation and any resulting damage. Please check and reighten all screws at regular intervals.
IT	Avvertenza: Se con il prodotto sono forniti tasselli e viti, questi sono destinati esclusivamente all'utilizzo su pareti realizzate con materiali solidi ed uniformi, per evitare il ribaltamento. Prima di eseguire i fori assicurarsi che non ci siano condutture di gas, acqua o elettriche vicino al punto di perforazione. Per il fissaggio ad altre pareti è necessario utilizzare tasselli speciali. Chiedete al proprio rivenditore le viti e/o tasselli adatti al tipo di parete in questione. Il produttore non si assume alcuna responsabilità in caso di montaggio improprio e dei danni che ne derivano. Controllare e serrare tutte le viti a distanza regolare.
PL	Uwaga: Jeżeli do towaru dołączone są kołki i śruby, są one przeznaczone wyłącznie do stosowania na ścianach wykonanych z solidnych i jednorodnych materiałów, aby zapobiec przewróceniu. Przed rozpoczęciem wiercenia należy upewnić się, że w miejscu wiercenia nie są ułożone rury gazowe, wodociągowe lub przewody elektryczne. Do mocowania do innych ścian należy stosować kołki specjalne. O śruby lub kołki odpowiednie dla konstrukcji danej ściany należy pytać w sklepach specjalistycznych. Producent nie ponosi odpowiedzialności za nieprawidłowy montaż i wynikię z tego tytułu szkody. Wszystkie śruby należy regularnie sprawdzać i dokręcać.
ESP	Advertencia: En el caso de incluirse tacos y tornillos con la mercancía, estos están previstos únicamente para su uso en paredes macizas y homogéneas a fin de evitar un posible vuelco. Antes de taladrar, asegúrese de que por el punto de perforación no pasen tuberías de gas o agua o cables eléctricos. Para la fijación en otro tipo de paredes deben utilizarse tacos especiales. Pregunte en la tienda por los tornillos o tacos adecuados para las características de la pared en cuestión. El fabricante no asume ninguna responsabilidad por un montaje incorrecto ni por los datos resultantes del mismo. Compruebe todos los tornillos en intervalos regulares y apriételos.
CZ	Výstrážné upozornění: Pokud jsou k tovaru přiloženy hmoždinky a šrouby, jsou určeny výhradně pro použití do stěn zhotovených z masivních a homogenních materiálů, a to za účelem zajištění proti převrácení. Před vrtáním se ujistěte, že se v místě vrtání nachází vedení plynů, vody nebo elektřiny. Pro připevnění k jiným stěnám je nutné použít speciální hmoždinky. Informujte se v obchodě o hmoždinkách a/nebo šroubech vhodných pro příslušnou strukturu stěny. Vyroba nenese odpovědnost za nesprávnou montáž a za škody jí způsobené. Všechny šrouby pravidelně kontrolujte a dotahujte.
SK	Informácia o nebezpečenstve: Ak sú k tovaru priložené príchytky a skrutky, sú určené výlučne na použitie na stenách z masívnych a jednotných materiálov, aby sa zabránilo prevráteniu. Pred vrtaním sa uistite, že sa na vrtanom mieste nachádzajú žiadne plynové, vodovodné alebo elektrické vedenia. Na upevnenie na iných stenách musia byť použité špeciálne príchytky. Sťažujte sa v predajni na skrutky a/alebo príchytky vhodné pre príslušnú štruktúru steny. Vyroba nepreberá zodpovednosť za nesprávny montáž a za škody, ktoré vzniknú v pravidelných intervaloch kontroly a dotiahnutia.
HU	Figyelmeztetés: Amennyiben a termék csomagolásá melléket és csavarokat is tartalmaz, azok kizárólag masszív, egységes anyagból készült falakon használhatók, a felbontás megakadályozásának céljából. A fúrás előtt bizonyosodjon meg arról, hogy a fúrás helyén nem található gáz-, víz-, vagy elektromos vezeték. Egyszeri falakra történő rögzítéshez speciális trépl szakszögessék. Az egyes falpontosokkal használható megfélelő csavarokkal és/vagy tréplkel csavarokkal információkért kérjük, forduljon forgalmazójához. A nem szakaszterti szerelésért és az abból keletkező károkatól a gyártó semmilyen felelősség nem terheli. Minden csavart ellenőrizzen és rögzítés rendszerezzen.
BG	Предупредително указание: Ако в окомплектовката на доставката на стоката са включени дюбели и винтове, те са предназначени единствено за употреба върху стени от масивни и еднородни материали. За да се предотврати преобръщане. Преди пробиване се уверете, че на мястото на пробиване няма тръби за газ, за вода или електрически проводници. За закрепване към други стени трябва да се използват специални дюбели. Информирайте се в търговската мрежа относно подходящите винтове и/или дюбели за съответната конструкция на стената. Производителът не поема отговорност за неправилен монтаж и възникнали в резултат на това щети. Моля, проверявайте и завличайте всички винтове на редовни интервали.
TR	Uyarı: Ürün paketinde dibel ve vida varsa, bunlar devrilmeyi önlemek amacıyla, sadece masif ve tekparce malzemelerden imal edilmiş duvaratakları kullanılm için uygundur. Malzeme delik açmadan önce delme noktasında gaz, su veya elektrik hatlarından emin olun. Ürünü başka duvarata sbitirmek için özel dibeller kullanmalısınız. Fırsadakti sathclardan ilgili duvarata özelinde uygun vidaları ve dibelleri hakkinda bilgi alın. Usulüne aykırı bir montaj ve bu nedenle oluşmuş hasarlar için üretici sorumluluk almamaktadır. Lütfen tüm vidaları düzenli aralıklarla kontrol edip sıkarak sıkın.

PT	Advertência: Caso o produto venha com buchas e parafusos inclinados, os mesmos são exclusivamente destinados à fixação em paredes de materiais sólidos e uniformes, para evitar que o produto tombe. Antes de iniciar a perfuração, certifique-se de que não existem canalizações de gás, água ou fios elétricos a passar no local dos furos. Para a fixação no/roto tipo de paredes, têm de ser utilizados buchas especiais. Informe-se junto de um comerciante especializado sobre os parafusos e buchas a utilizar na parede específica. O fabricante não assume qualquer responsabilidade no caso de uma montagem inadequada e qualquer dano daí resultante. Verifique e volte a apertar todos os parafusos regulamente.
SI	Opozorilo: Če so blagu priloženi zidni vložki in vijaki, so ti namenjeni izključno za uporabo na stenah iz masivnih in enotnih materialov, da se prepreči prevrnitev. Pred vrtanjem se prepričajte, da na mestu vrtanja ni plinskih, vodnih ali električnih napeljav. Za pritrditev na druge stene je treba uporabljati posebne zidne vložke. Pozornost je v tveganju o vijakih in/ali zidnih vložkih, priletnih za posamezno sestavo stene. Proizvajalec ne prevzema jamstva za nepravilno montažo in zaradi tega nastalo škodo. Vse vijake redno preverjajte in naknadno pritrdite.
NL	Waarschuwing: Indien er bij het product pluggen en schroeven zijn meegeleverd, zijn deze uitsluitend bestemd om in muren van massieve en homogene materialen te gebruiken om te voorkomen dat het product kantelt. Controleer voordat u begint of er geen gas-, water- of elektriciteitsleidingen lopen waar u gaat boren. Voór de bevestiging aan andere soorten muren moeten speciale pluggen worden gebruikt. Informeer in de winkel welke schroeven en/of pluggen geschikt zijn voor de desbetreffende muur. De fabrikant is niet aansprakelijk voor een onjuiste montage en de daardoor ontstane schade. Controleer regelmatig of alle schroeven nog goed vastzitten en draai ze zo nodig vast.
SRB	Priložena upozorenja: Ako su uz robu priloženi tločvici i zavrtci, isti su namenjени isključivo za primenu na zidovima od kompaktnih i homogenih materijala, kako bi se sprejelo prevrtanje. Pre bušenja se uverite da se na mestu bušenja ne nalaze vodovi za gas, vodu ili struju. Za fiksiranje na drugačijiim zidovima moraju da se upotrebe specijalni tločvici. Raspricajte se u trgovini o zavrtcima i/ili tločvicima koji su adekvatni za dotični teksturni zid. Proizvođač ne preuzima nikakvu odgovornost za neispravan montažni i štete koje su nastale na taj način. Sve zavrtanje kontrolisite i doterajte u redovnim intervalima.
RO	Indicație de avertizare: Dacă produsul este livrat împreună cu șuruburi și dibluri, acestea sunt destinate exclusiv utilizării pe pereți construiți din materiale masive și uniforme, pentru a preveni răsturnarea produsului. Înainte de a realiza găurile, asigurați-vă că nu există conducte de gaz, apă sau electricitate în locul pe care doriți să-l găuriți. Pentru prinderea pe alte tipuri de pereți, trebuie să utilizați dibluri speciale. Interesați-vă la magazinul specializat, pentru a găsi șuruburile și/sau diblurile potrivite pentru pereții dvs. Producătorul nu este responsabil în cazul unui montaj necorespunzător pentru daunele rezultate. Vă rugăm să verificați toate șuruburile la intervale regulate și să le strângeți.
HR	Upozorenje: Ako su uz proizvod priložene tločvice i vijci, oni su namijenjeni isključivo za korišćenje na zidovima od čvrstih i jednoličnih materijala kako bi se spriječilo prevrtanje. Prije bušenja provjerite da na mjestu bušenja nema električnih vodova, plinskih ili vodovodnih cijevi. Za pričvršćivanje na ostale zidove potrebno je koristiti posebne tločvice. Priklonom kupnje raspričajte se kod svog prodavača o vijcima i tločvicama koji su prikladni za odgovarajuću zidnu strukturu. Proizvođač ne odgovara za štete nastale uslijed nepravilne montaže. Sve vijke potrebno je redovito provjeravati i zategnuti.
SE	Varning: Om plugg och skruvar följer med produktén är de endast avsedda för väggar av massivt och enhetligt material för att förhindra att produktén vrillar. Försäkra dig om att inga gas-, vatten- eller elledningar befinner sig på platsen som du ska bota innan du börjar. För fastsättning i väggen måste specialplugg användas. Informera dig i en butik om vilka skruvar och pluggar som passar till vilken vägg. För en felaktig montering och skador som uppstår på grund av detta tar tillverkaren inget ansvar. Kontrollera och dra åt alla skruvar med jämna mellanrum.
RUS	Предупреждение: Если изделие поставляется вместе с дюбелями и шурупами, они предназначены исключительно для использования на стенах из монолитных и однородных материалов, чтобы предотвратить возможное обрушение. Перед началом сверления убедитесь, что на месте сверления нет газопровода, водопровода или электропроводки. Для крепления в других стенах необходимо использовать специальные дюбели. Узнайте у продавца, какие шурупы или дюбели подойдут для соответствующей структуры стены. Производитель не несет ответственности за неправильный монтаж и вызванный им ущерб. Регулярно проверяйте все шурупы.
UKR	Попередження: Якщо до виробу додаються дюбелі та гвинти, вони призначені виключно для використання на стінах з цільних й однорідних матеріалів, щоб не допустити перекидання. Перед сверлінням переконайтеся, що на місці сверління немає ліній газу, водопостачання чи електропроводки. Для кріплення до інших стін необхідно використовувати спеціальні дюбелі. Запитайте продавця, які гвинти та/або дюбелі підходять для стіни з відповідною структурою. Виробник не несе відповідальності за неправильний монтаж та збитки, що виникли внаслідок цього. Перевіряйте та підтягуйте всі гвинти через регулярні проміжки часу.
LT	Įspėjimas: Jei prie prekės pridėtos tvirtinamosios detalės ir varžtai, jie skirti naudoti tik ant sienų, parengtųjų iš tvirtų ir vieningų medžiagų, kad būtų galima išvengti arvučimo. Prieš gręžiamąją vietoje nėra dujų tinkle, vandentiekio ar elektros linijų. Tvirtinamieji prie kito tipo sienų reikia naudoti specialias tvirtinimo detales. Teiktuvėms patarėję atitinkamai sienos konstrukcijai tinkamų varžtų ir (arba) tvirtinimų. Gamintojas neįrašoma atsakomybės dėl netinkamo montavimo ir dėl to atsiradusios žalos. Visus varžtus reguliariai tikrinkite ir pritvirtinkite.
LV	Brīdinājums: Ja presei ir piederoti detaļi un skrūves, presei ir paredzēta izmantošanai tikai uz sienām, kas izgatavotas no cietiem un viendabīgiem materiāliem. Lai novērstu arvučim, pirms urbšanas pārbaudiet, ka urbumā nav gāzes, ūdens vai elektroprovokācijas līniju. Lai piesūrinātu prie citām sienām, jāizmanto speciāli detaļi. Jautājiet savam izplatītājam par skrūvēt un/vai detaļēm, kas ir piemēroti attiecīgajai sienas konstrukcijai. Ražotājs neuzņemas atbildību par nepareizu montāžu un no tās sekotājajiem bojājumiem. Līdzai, regulāri pārbaudiet un piederotie visas skrūves.
EE	Hoiatus! Kui tootele on kaasa pandud tihviid ja kiviid, on need mõeldud kasutamiseks üksnes massiivset ja ühtset materjalist seinel, vältimaks ümberkallumist. Veenduge enne ruumimist, et ruumimisvõttes ei oleks gaasi- või veevõrgusid ega elektrijuhtmeid. Seintel kiimpamiseks tuleb kasutada spetsiaalsed tihviid. Jutuge kaubandusõigusel, millised kiviid ja/või tihviid konkreetse seinla jaoks sobivad. Tooteja ei võta endale tihveniütekohasest raijaladmisest tingitud kahjude eest mingit vastutust. Kontrollige ja jätkerimistage kõiki kiviiviseid regulaarselt.



FR
Donnez ou recyclez
vos meubles.



ou



ou



ou

Association

Magasin

Déchèterie

<https://quefairemedesdechets.fr>