

**OPTIFIT**<sup>®</sup>



JAKA-BKL GmbH  
Jaka Straße 3  
D-32351 Stemwede-Wehden



# Montage

710 711 712  
713 714  
715 716

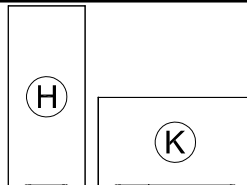
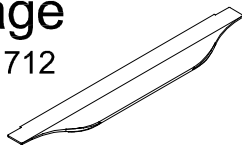

3x 4x 5x  
3,5x15  
Nr.157

4x  
Ø5/Ø8  
Nr.102

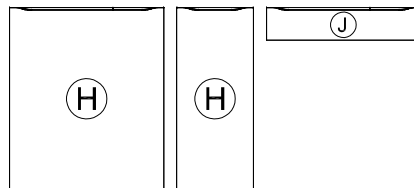
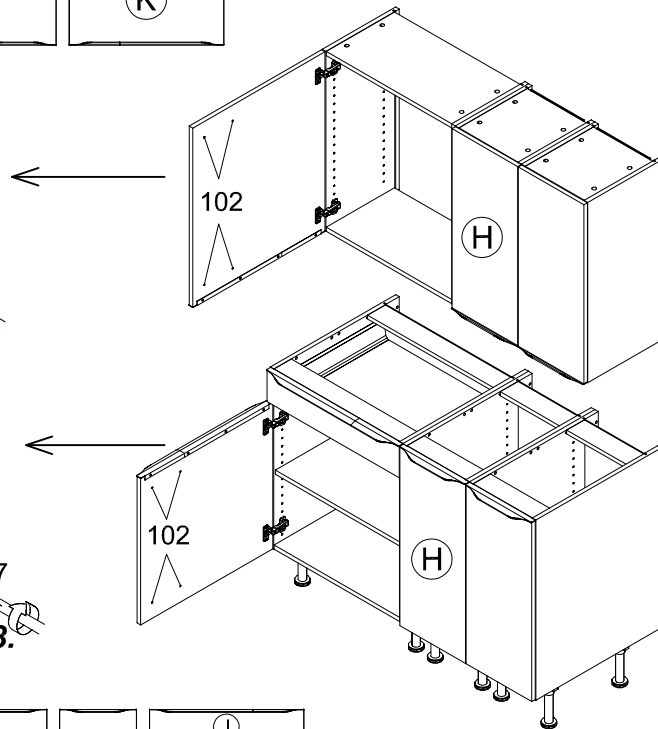
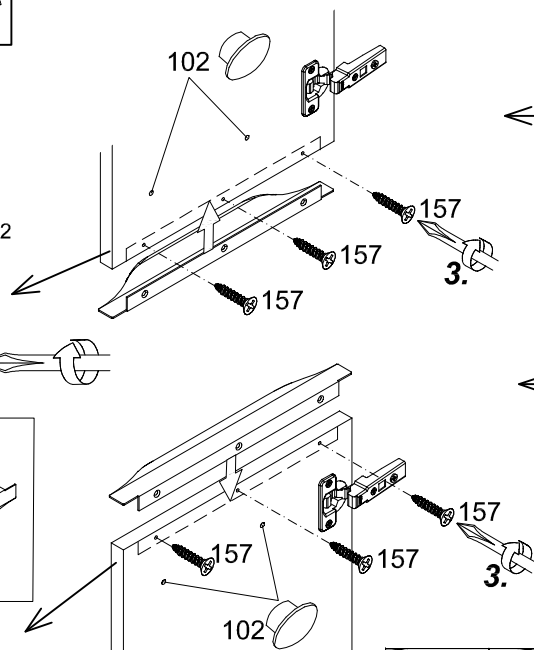
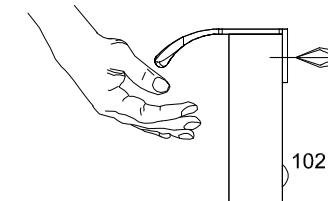
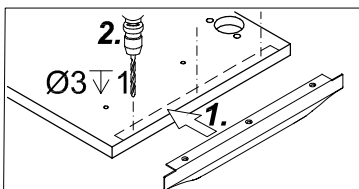
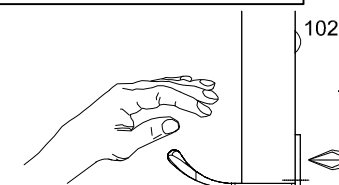

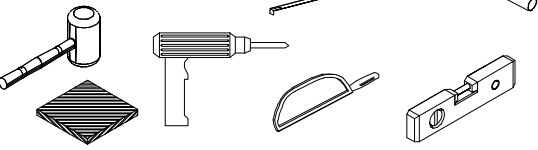

# Montageanleitung

**Service-Hotline**  
01805-678101  
0,14€ pro Minute  
**++49 für Österreich**  
Auslandstarif pro Minute  
**service@jaka-bkl.de**  
voor Nederland en België  
**00800-40119350**  
**benelux@jaka-bkl.de**

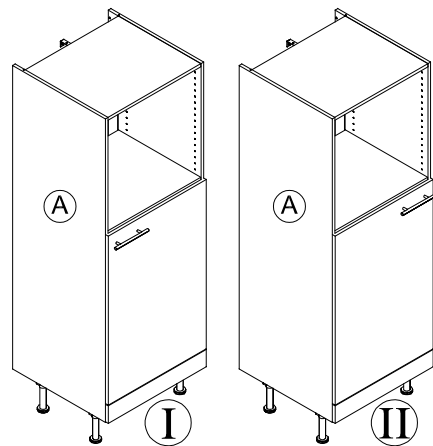

MH660-3D  
MH660-8  
VMH660-3

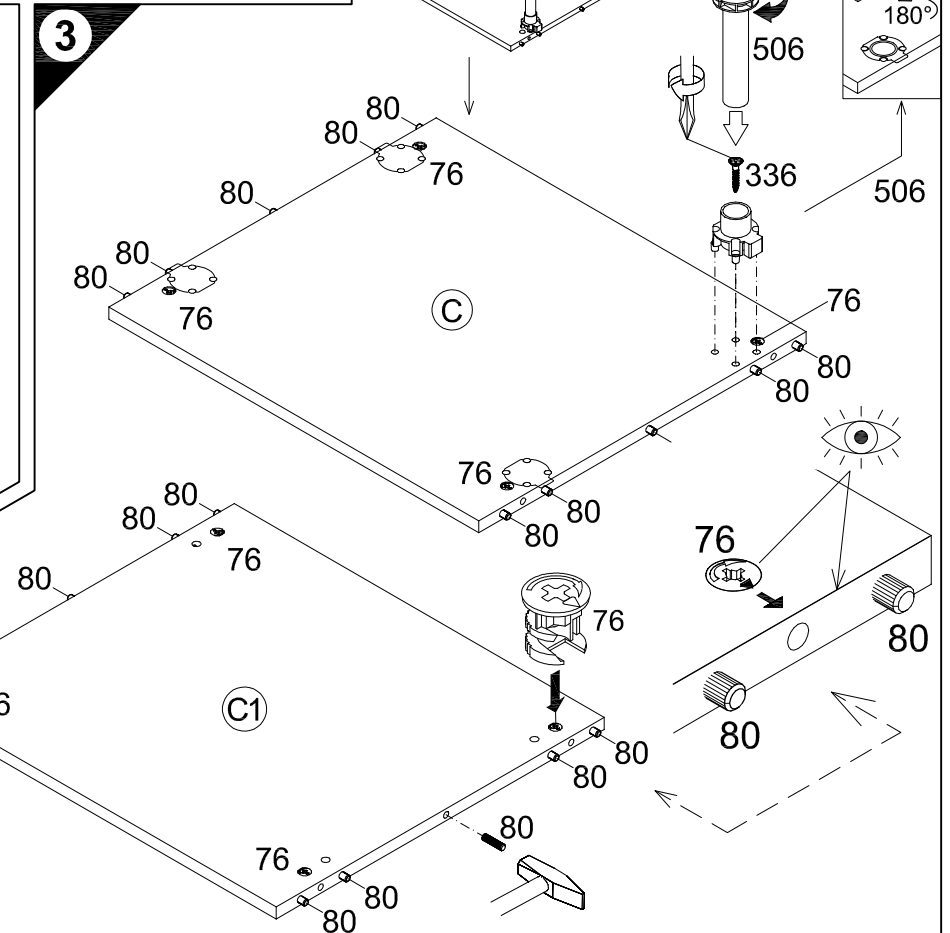
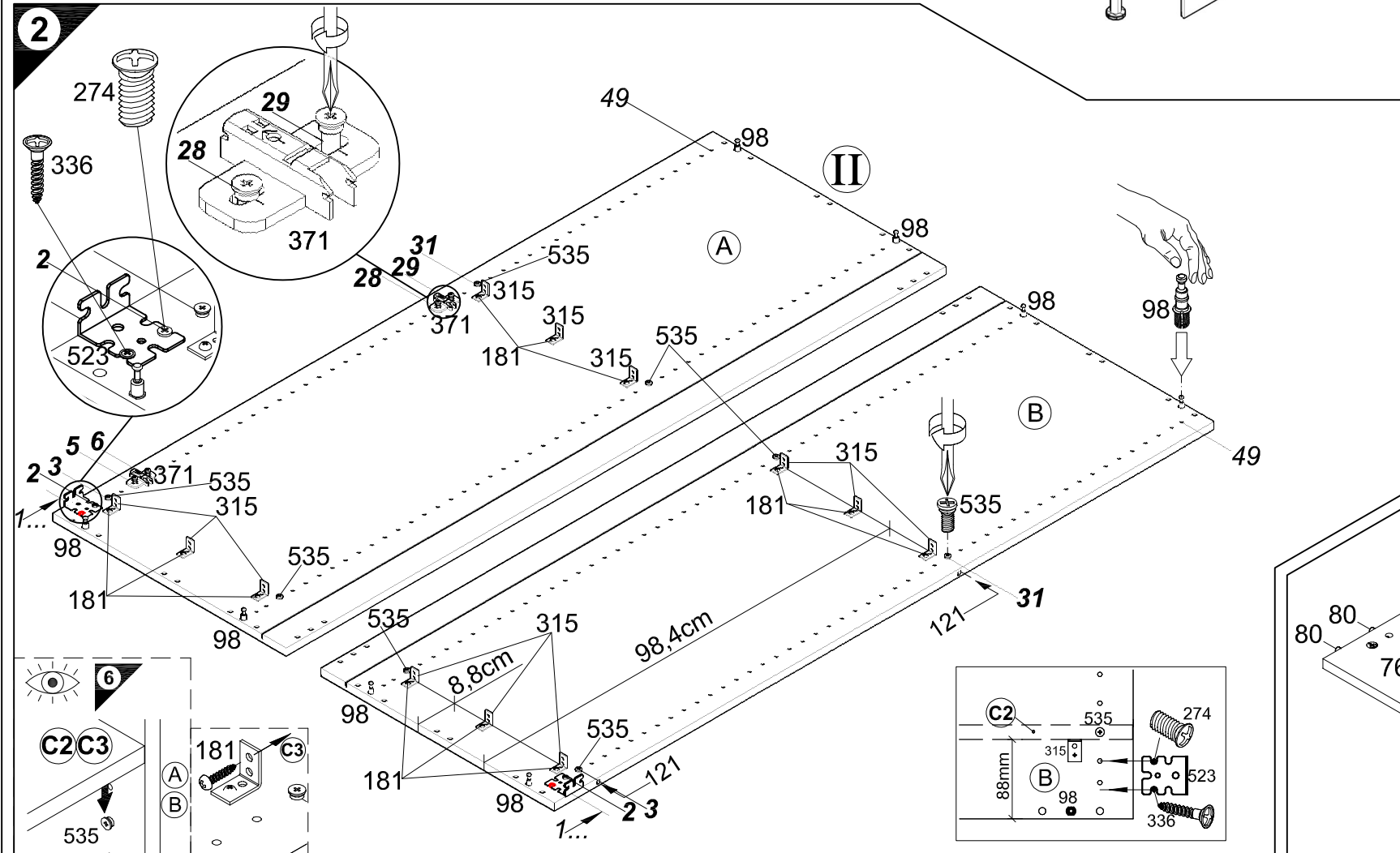
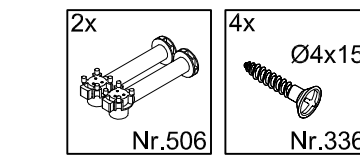
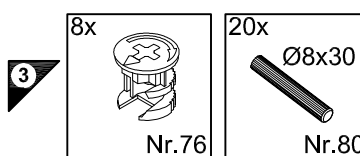
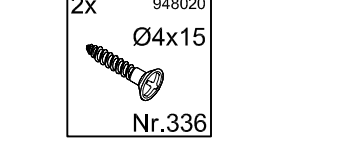
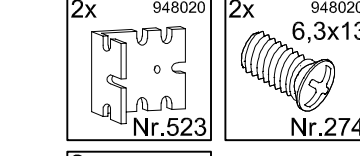
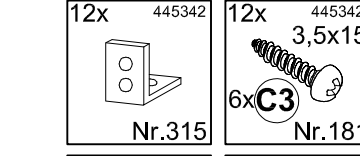
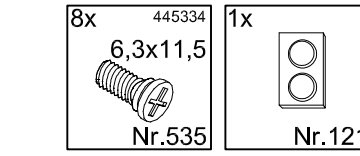
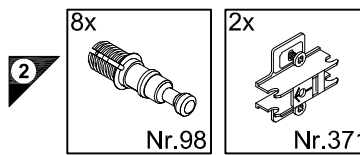
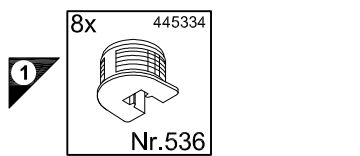
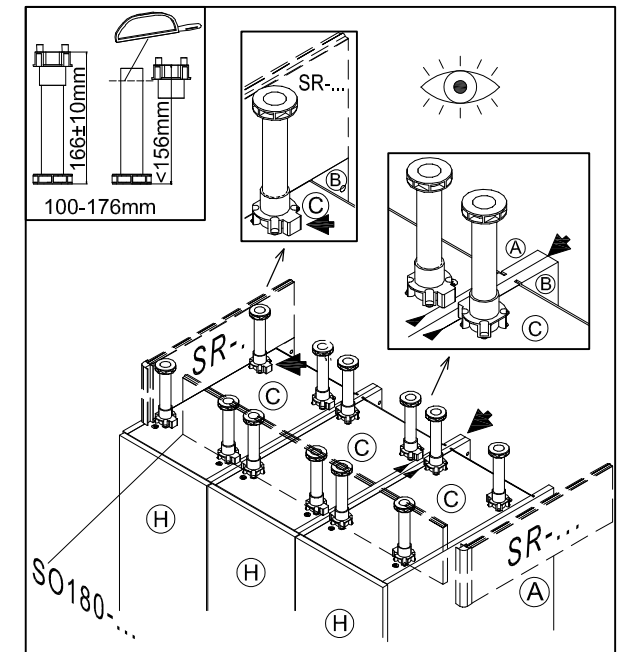
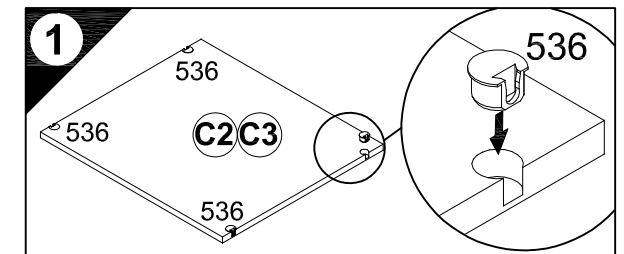
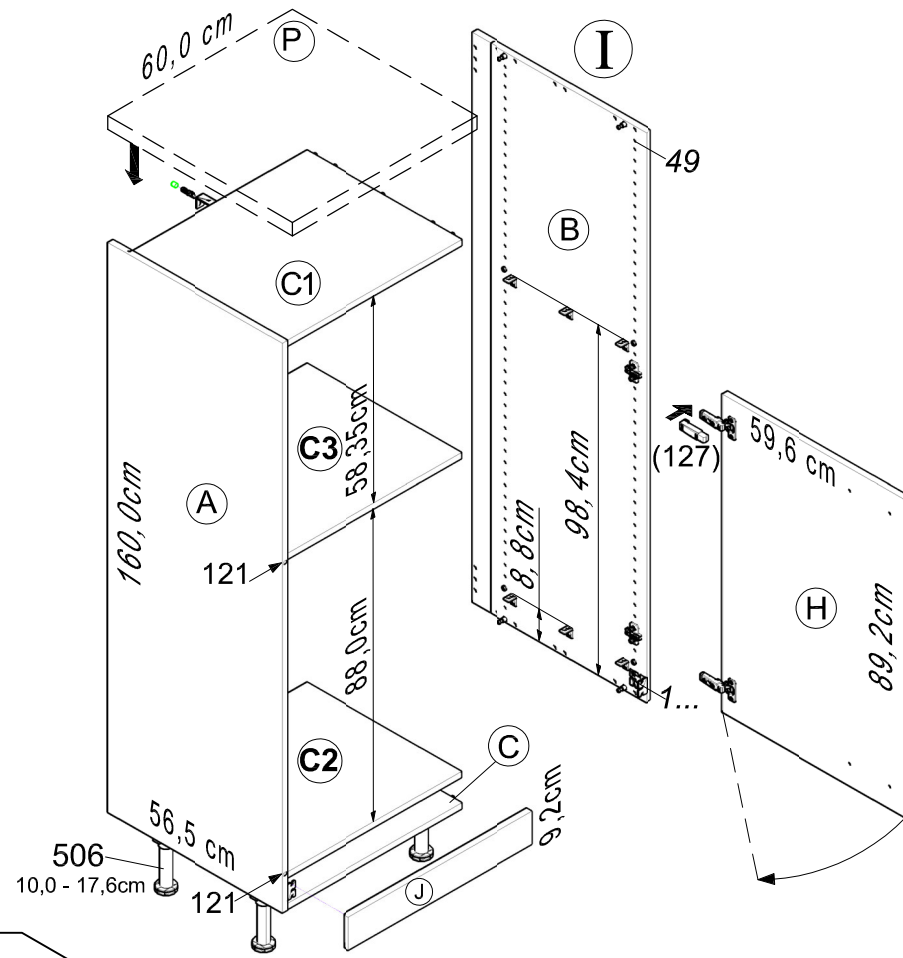
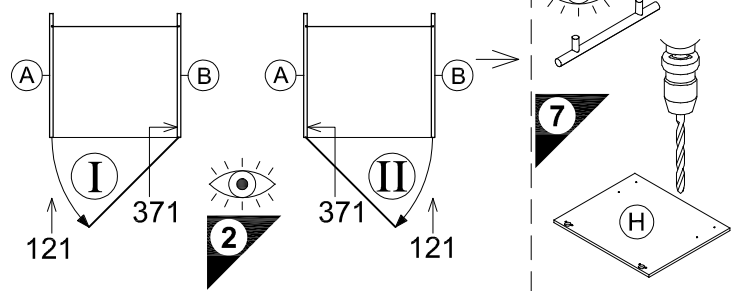

1 → 2 → 3 ...

- 5 2x 948020 6,3x13 Nr.274
- 8 2x Nr.370
- 10 1x 419153 Nr.127
- 11 2x 4,5x30 Nr.417
- 12 1x Ø8x40 Nr.70
- 1x 4,5x45 Nr.175
- 1x Nr.214
- 2x 4,5x15 Nr.191
- 13 1x Nr.505
- 15 4x 946366 4x30 (P) Nr.164

MH660-3D  
VMH660-3

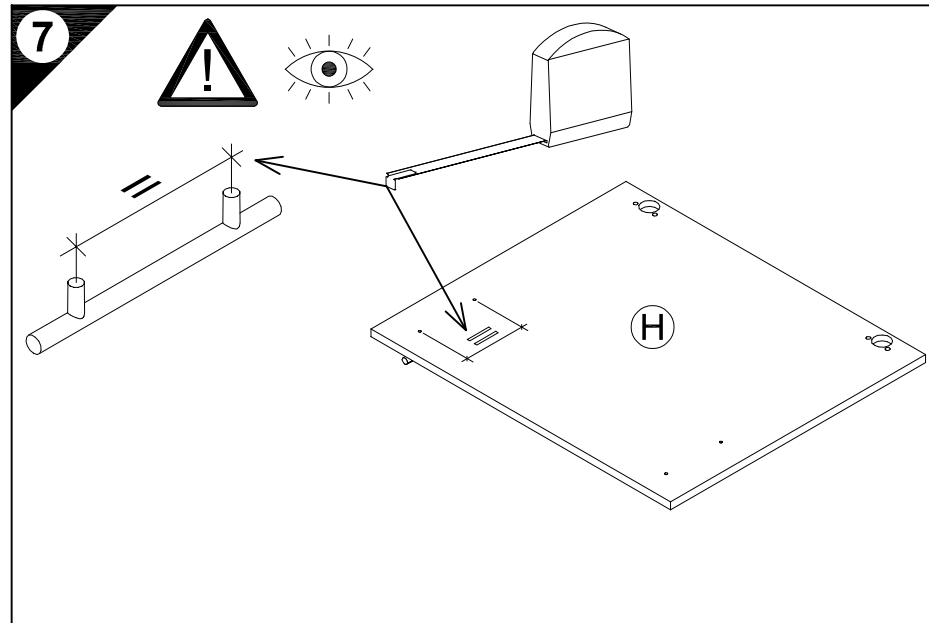
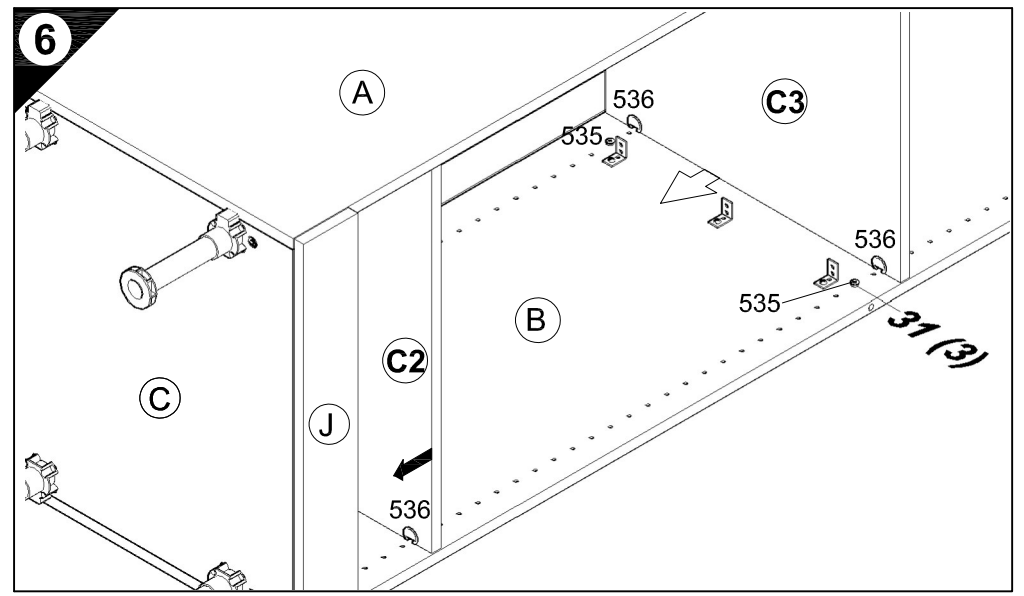
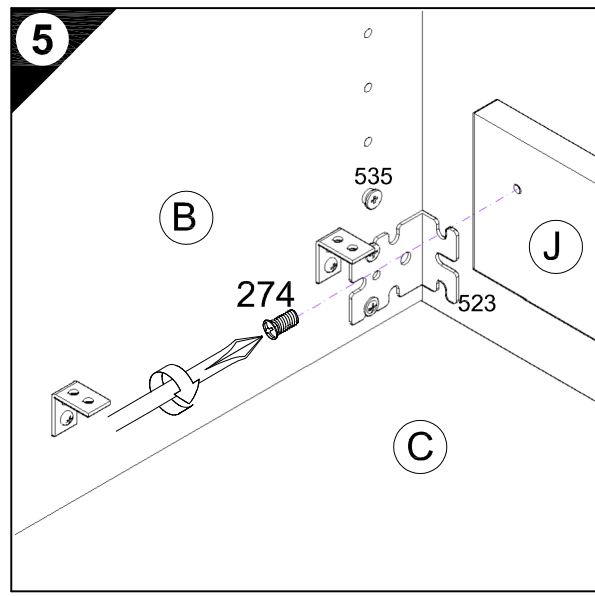
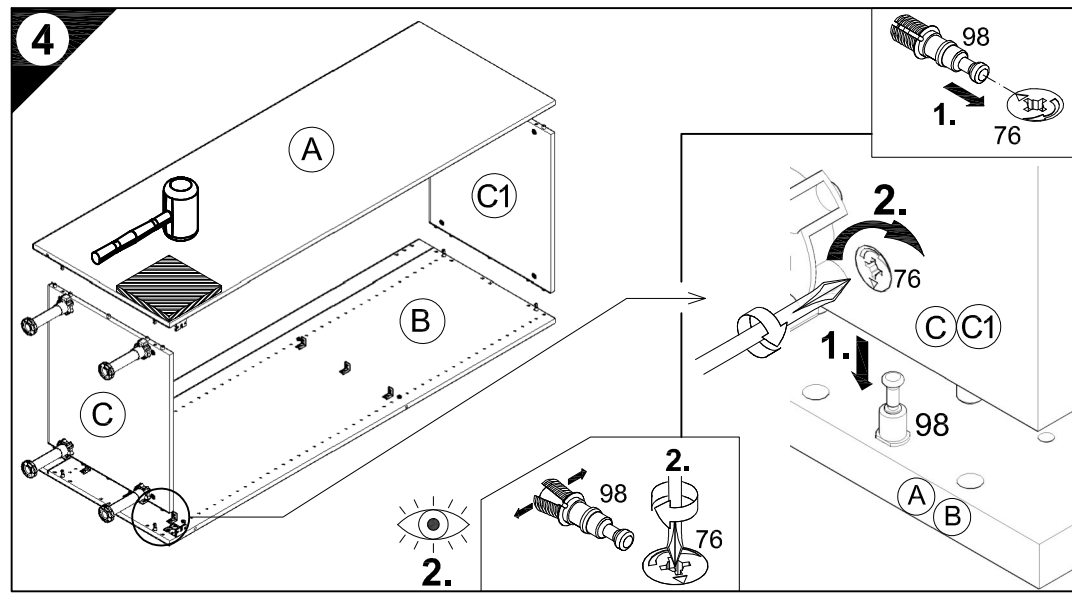

D Holzunterlage verwenden!  
Front andrücken, scharfen Bohrer verwenden und mit wenig Druck durchbohren!

GB Use a wooden base!  
Press front down, use sharp drill bit and, by applying slight pressure, drill a hole

F Utiliser un support en bois !  
Appuyer sur la façade, utiliser un foret bien affûté et percer en appliquant une faible pression !

NL Houten onderlegger gebruiken!  
Druk het front aan, gebruik een scherpe boor en oefen bij het boren weinig druk uit!

E ¡Utilizar una base de madera!  
¡Presionar el frente, utilizar una broca afilada y taladrar con poca presión!

I Utilizzare una base di legno! Appoggiare la facciata, utilizzare una punta di trapano affilata e trapanare esercitando solo una leggera pressione!

RUS Использовать деревянную подложку!  
Прижать фасад, использовать острое сверло и просверлить с незначительным давлением!

PL Używać podkładkę z drewna!  
Docisnąć front, użyć ostrego wiertła i przewiercić, używając małej siły nacisku!

H Alkalmazzon fa alátétet!  
Nyomja le az előlapot, használjon éles fúró, és kis nyomással fúrja át!

CZ Použijte dřevěný podklad!  
Přitlačte čelo, použijte ostrý vrták a provrtějte pomocí malého tlaku!

SLO Uporabite leseno podlago!  
Pritisnite ličnico ter z ostrim svedrom in z majhnim pritiskom izvrtajte luknjo!

FIN Käytä puualustaa!  
Paina etulevy paikoilleen, käytä terävää poranterää ja poraa reikä vain kevyesti painamalla!

S Använd ett träunderlag!  
Tryck fronten mot underlaget, använd vass borrh och borra igenom med ett lätt tryck!

SK Použite drevený podklad!!  
Pritlačte front, použite ostrý vrták a prevrtajte miernym tlakom!

RO suport de lemn! Împingeți frontul, utilizați un burghiu ascuțit și perforați exercitând doar o presiune redusă!

TR Ahşap taban kullanın!  
Önden bastırın, keskin matkap ucu kullanın ve az basınç uygulayarak delin!

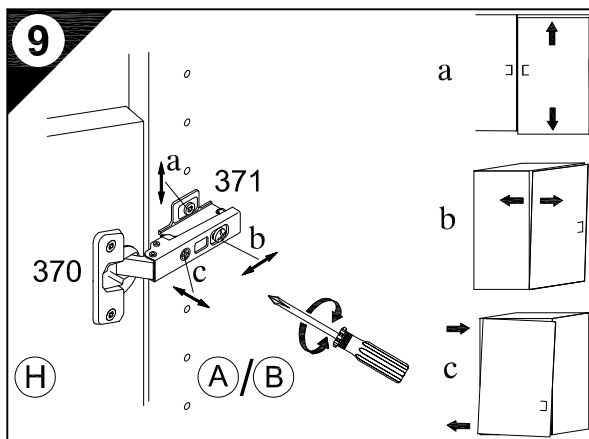
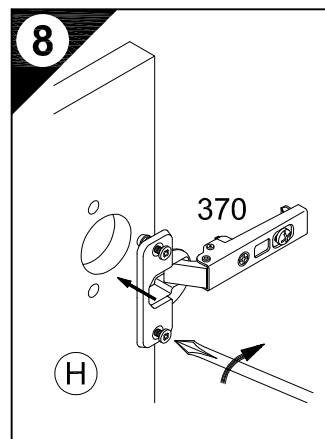
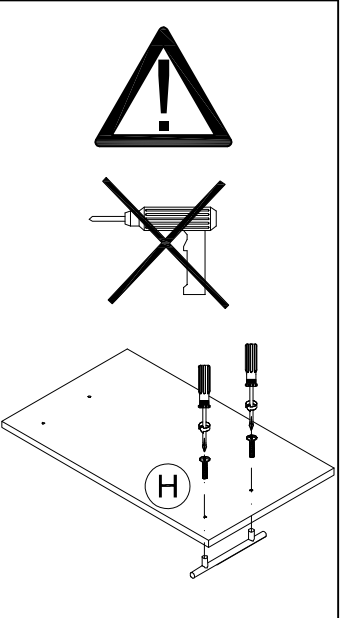

MH660-3D  
VMH660-3

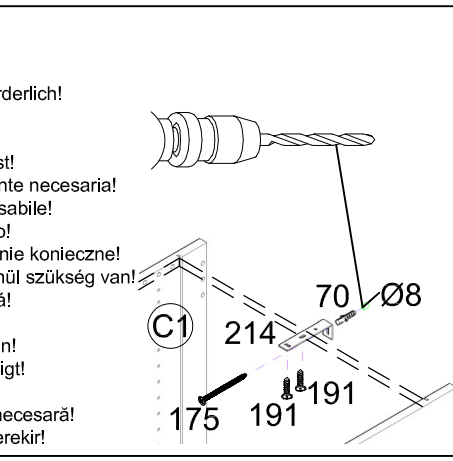
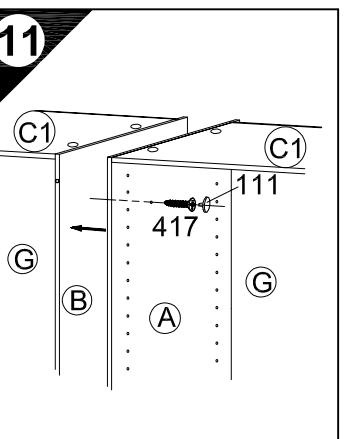
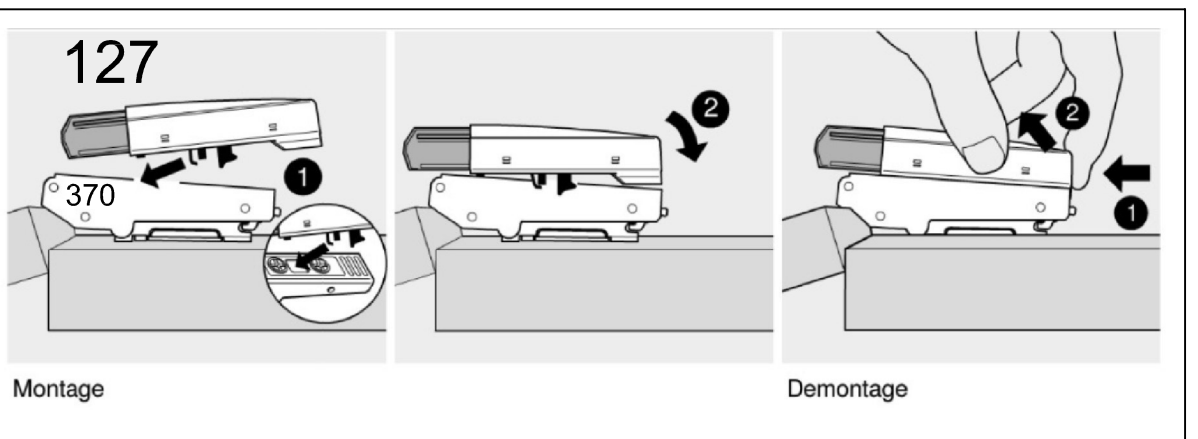

D Wandbefestigung zwingend erforderlich!  
Wall fixing essential!

GB Check substructure and fixings for suitability!

F A fixer impérativement au mur!  
Contrôler si le support et les moyens de fixation sont bien adéquats !

NL Wandbevestiging dringend vereist!  
Ondergrond en bevestigingsmateriaal op functionaliteit controleren!

E ¡Fijación en la pared absolutamente necesaria!  
¡Comprobar el suelo y los medios de fijación en cuanto a su aptitud!

I Il fissaggio alla parete è indispensabile!  
Controllare l'idoneità del fondo e del materiale di fissaggio!

RUS Крепление к стене обязательно!  
Основание и крепежный материал проверить на пригодность!

PL Mocowanie do ściany bezwzględnie konieczne!  
Podłoże oraz materiały do zamocowania sprawdzić na ich przydatność!

H A falra törtéző rögzítésre feltétlenül szükség van!  
Az alapfelületet és a rögzítő anyagokat megfelelőség szempontjából ellenőrizni kell!

CZ Nástěnná montáž nezbytně nutná!  
Přezkoušejte podklad a vhodnost upevňovacích prostředků!

SLO Obvezna je pritrditev na steno!  
Preverite, če se ujema spodnja stran in pritrdilna sredstva!

FIN Kiinnitettävä ehdottomasti seinään!  
Tarkista alustan ja kiinnitysvälineiden sopivuus!

S Ett väggfäste är absolut nödvändigt!  
Kontrollera att underlaget och fästmedlen är lämpliga!

SK Nutná montáž na stenu!  
Preverte vhodnosť podkladu a upevňovacích prostriedkov!

RO Fixarea la perete este neapărat necesară!  
Verificați caracterul adecvat al suprafeței suport și al mijloacelor de fixare!

TR Duvara sabitlenmesi kesinlikle gerekir!  
Zemin ve bağlanıtı elemanlarının uygunluğunu kontrol edin!

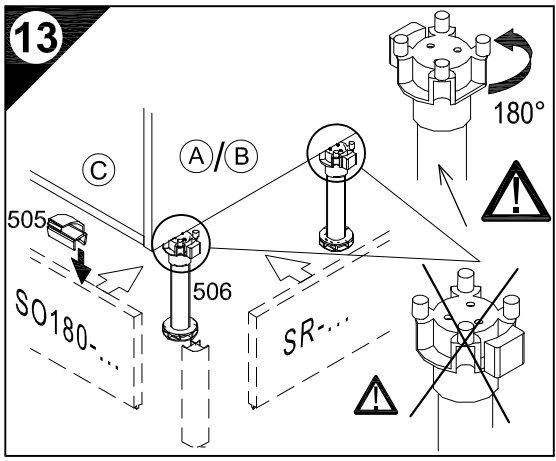

D Lüftungsgitter einbauen! (als Zubehör erhältlich)

GB Install ventilation grille (available as an accessory)

F Installer une grille d'aération ! (disponible en accessoire)

NL Luchtrooster inbouwen! (verkrjgbaar als accessoire)

E ¡Montar la rejilla de ventilación! (se puede obtener como accesorio)

I Montare la griglia di aerazione! (disponibile come accessorio)

RUS Встроить вентиляционную решетку! (продается как принадлежность)

PL Zamontować kratkę wentylacyjną! (dostępna jako dodatkowe wyposażenie)

H Építse be a szellőzőrácsot! (tartozékként kapható)

CZ Zamontujte větrací mřížku (k dodání jako příslušenství)

SLO Potrebna je vgradnja prezračevalne rešetke! (dobiljivo kot dodatna oprema)

FIN Asenna tuuletusgrillit! (saatavana lisävarusteena)

S Montera luftningsgallret! (Kan levereras som tillbehör)

SK Namontujte vetraciu mriežku! (dostupné ako príslušenstvo)

RO Montați grilajul de aerisire! (disponibil ca accesoriu)

TR Havalandırma izgarasını takın! (aksesuar olarak temin edilir)

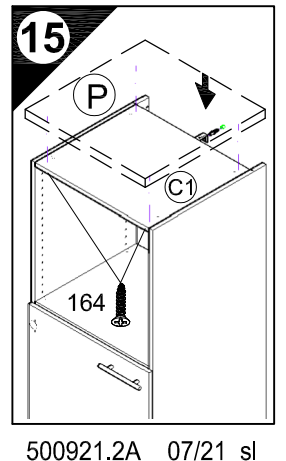

**OPTI FIT**

JAKA-BKL GmbH  
Jaka Straße 3  
D-32351 Stemwede-Wehden

Service-Hotline  
01805-678101  
0,14€ pro Minute

++49 für Österreich  
Auslandstarif pro Minute

service@jaka-bkl.de  
voor Nederland en België

00800-40119350  
benelux@jaka-bkl.de

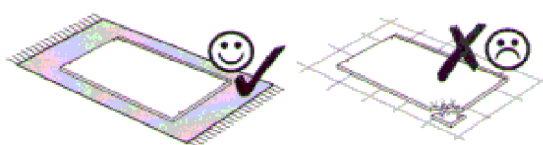
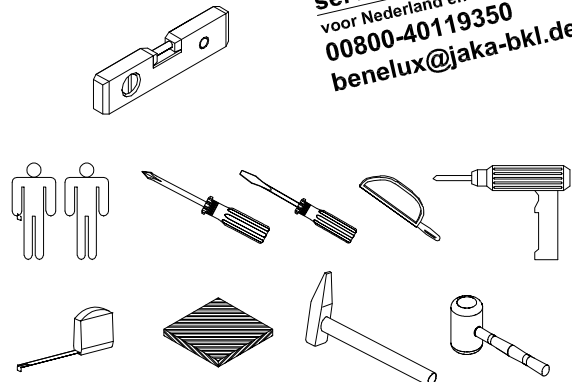

1 → 2 → 3 ...

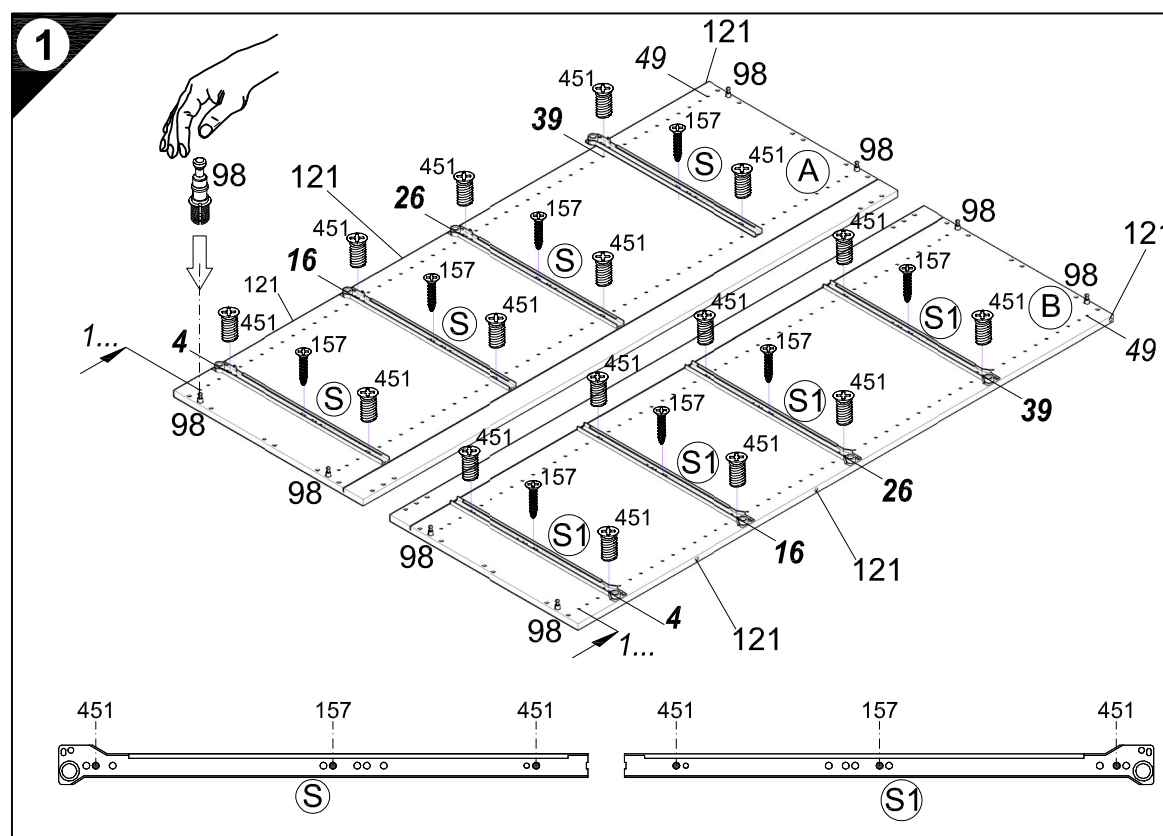
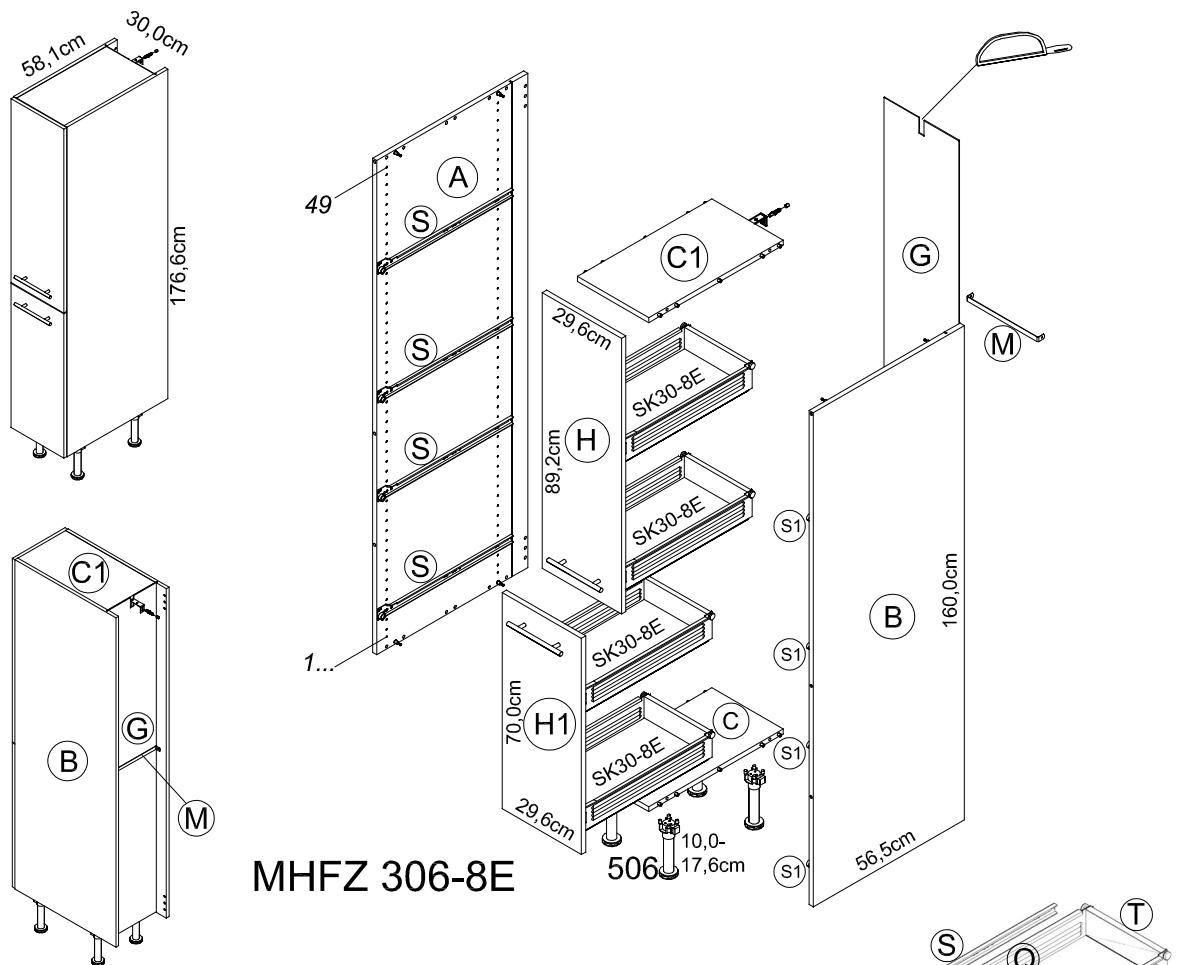
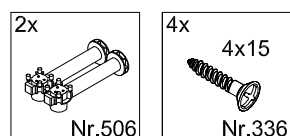
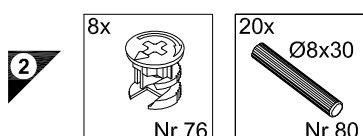
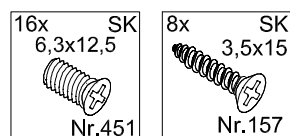
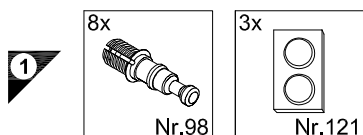

# Montageanleitung

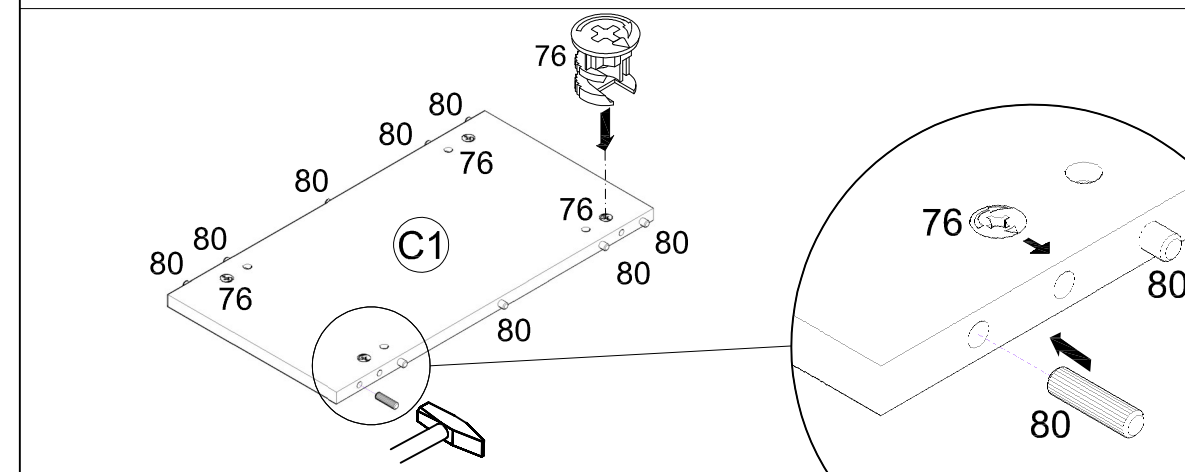
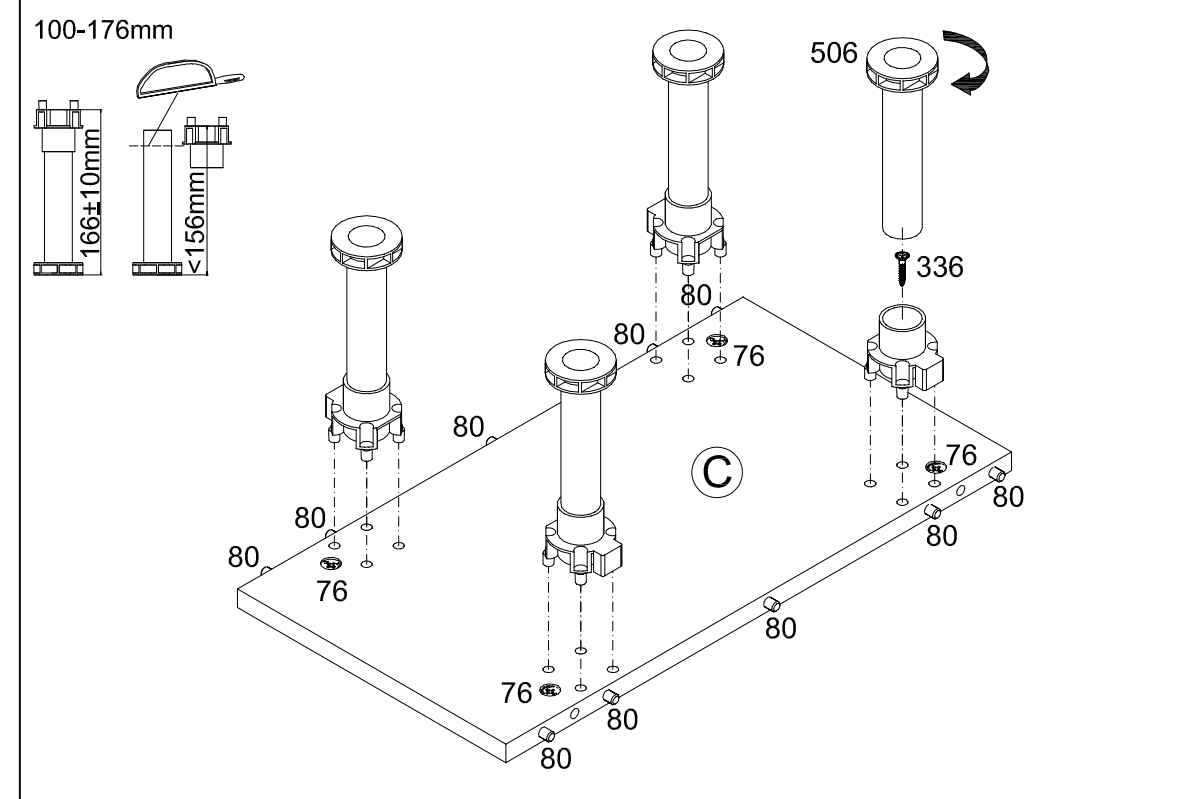
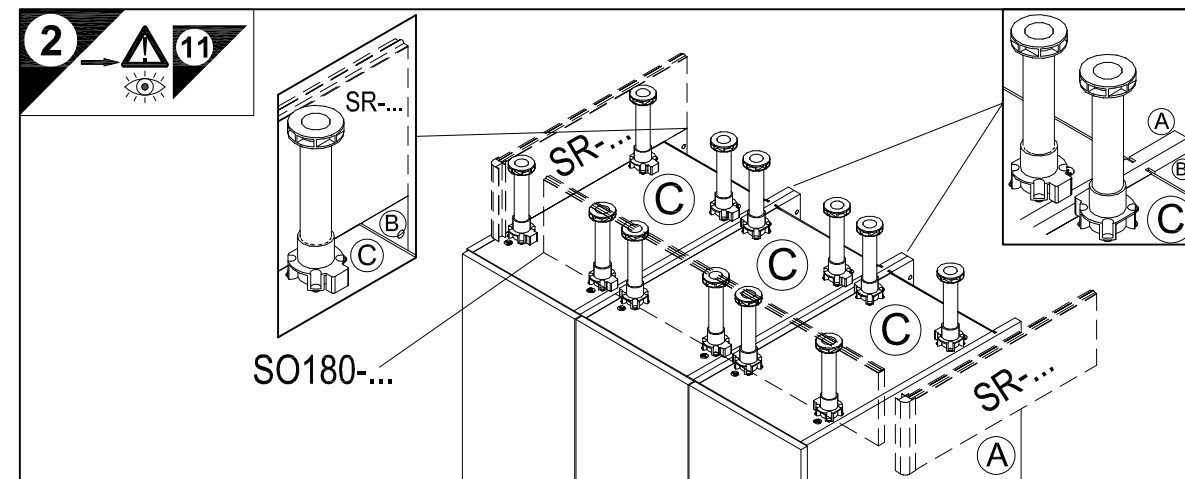

Ersatzteile/Spare parts/pièces de rechange/Reserveonderdelen/Piezas de recambio/Ricambi/Запасные части/Części zamienne/pótkatkrészek/Náhradní části/Nadomestni deli/varaosat/reservdelar/náhradné diely/Utilizați piese de schimb/Yedek parçalar

30cm MHFZ306-8E | [A] E941005 | [B] E941005 | [C] E951216 | [C1] E954216 | [G] E970036 | [H] E940603 | [H1] E940596 | [M] E948045 | [Q] E966001 | [Q1] E966002 | [R] E941951  
[S] E966003 | [S1] E966004 | [T] E941941

1 → 2 → 3 ...

- 5 10x 1,4x25 Nr.204
- 6 2x 3,5x15 Nr.181
- 7 2x 4,5x30 Nr.417
- 8 1x 4,5x15 Nr.191
- 10 16x SK Nr.391
- 11 1x Nr.505
- 2x Ø12 Nr.111
- 2x 4,5x15 Nr.191
- 1x Ø8 Nr.70
- 1x 4,5x45 Nr.175
- 16x SK 4x13 Nr.413
- 4x SK "Q"
- 4x SK "Q1"

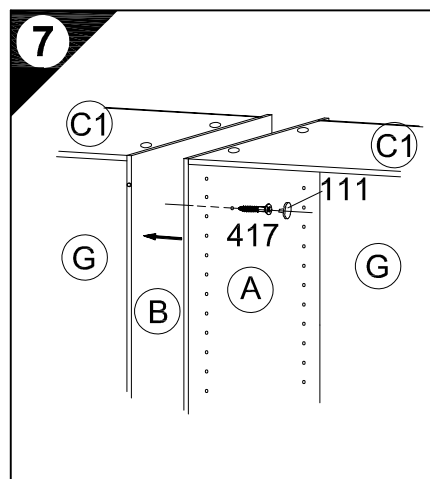
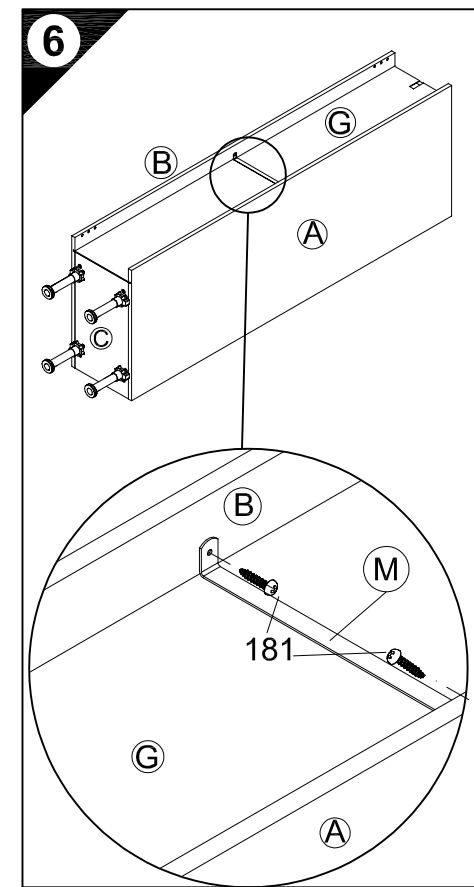
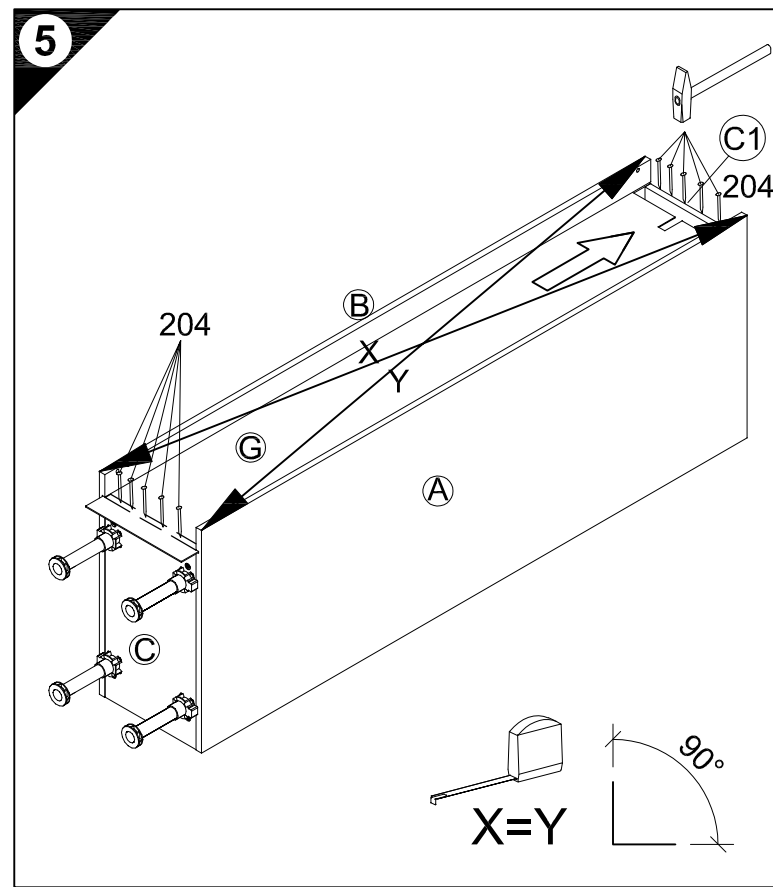
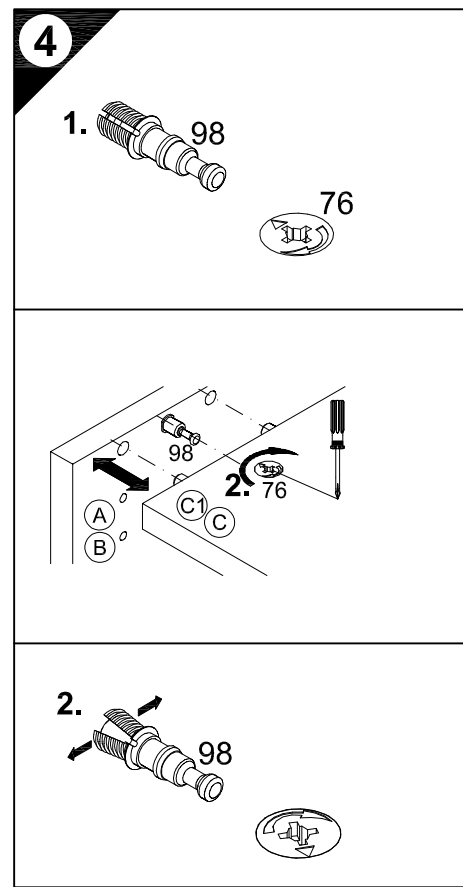
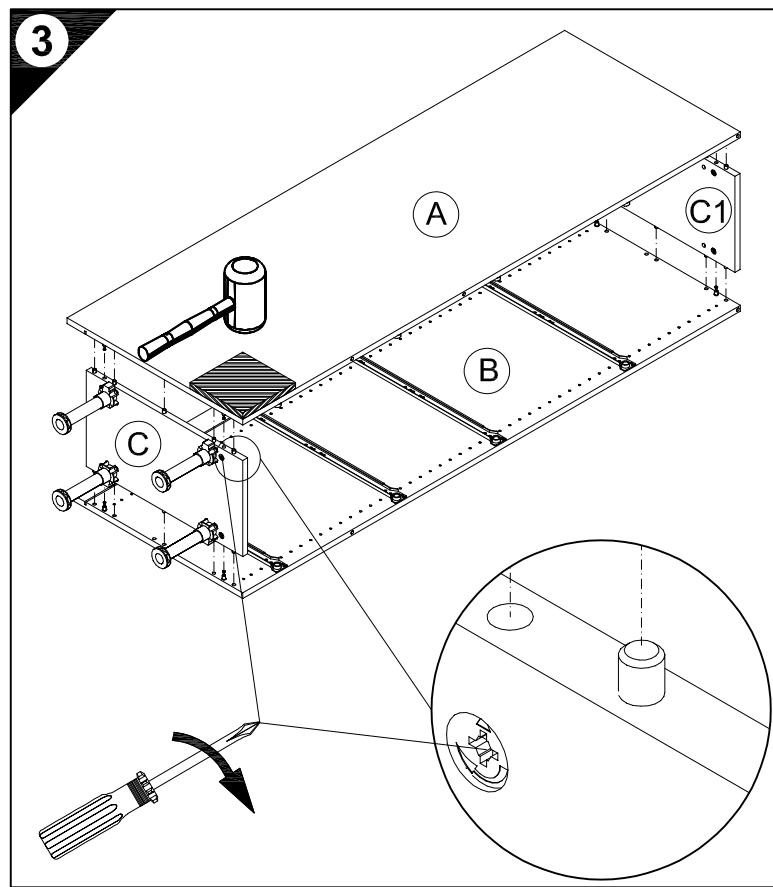

- 8
- D Wandbefestigung zwingend erforderlich!
  - GB Wall fixing essential!
  - F A fixer impérativement au mur!
  - NL Wandbevestiging dringend vereist!
  - E ¡Fijación en la pared absolutamente necesaria!
  - I Il fissaggio alla parete è indispensabile!
  - RUS Крепление к стене обязательно!
  - PL Mocowanie do ściany bezwzględnie konieczne!
  - H A falra történő rögzítésre feltétlenül szükség van!
  - CZ Nástěnná montáž nezbytně nutná!
  - SLO Obvezna je pritrđitev na steno!
  - FIN Kiinnitettävä ehdottomasti seinään!
  - S Ett väggfäste är absolut nödvändigt!
  - SK Nutná montáž na stenu!
  - RO Fixarea la perete este neapărat necesară!
  - TR Duvara sabitlenmesi kesinlikle gerekir!

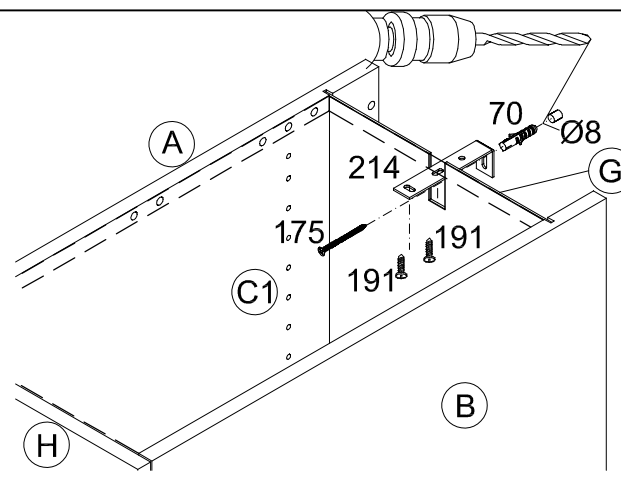

- D Untergrund und Befestigungsmittel auf Eignung prüfen!
- GB Check substructure and fixings for suitability!
- F Contrôler si le support et les moyens de fixation sont bien adéquats !
- NL Ondergrond en bevestigingsmateriaal op functionaliteit controleren!
- E ¡Comprobar el suelo y los medios de fijación en cuanto a su aptitud!
- I Controllare l'idoneità del fondo e del materiale di fissaggio!
- RUS Основание и крепежный материал проверить на пригодность!
- PL Podłoże oraz materiały do zamocowania sprawdzić na ich przydatność!
- H Az alapfelületet és a rögzítő anyagokat megfelelőség szempontjából ellenőrizni kell!
- CZ Přezkoušejte podklad a vhodnost upevňovacích prostředků!
- SLO Preverite, če se ujemajo spodnja stran in pritrđilna sredstva!
- FIN Tarkista alustan ja kiinnitysvälineiden sopivuus!
- S Kontrollera att underlaget och fästmedlen är lämpliga!
- SK Preverte vhodnosť podkladu a upevňovacích prostriedkov!
- RO Verificați caracterul adecvat al suprafeței suport și al mijloacelor de fixare!
- TR Zemin ve bağlanrı elemanlarının uygunluğunu kontrol edin!

- 9
- D Holzunterlage verwenden!  
Front andrücken, scharfen Bohrer verwenden und mit wenig Druck durchbohren!
  - GB Use a wooden base!  
Press front down, use sharp drill bit and, by applying slight pressure, drill a hole
  - F Utiliser un support en bois !  
Appuyer sur la façade, utiliser un foret bien affûté et percer en appliquant une faible pression !
  - NL Houten onderlegger gebruiken!  
Druk het front aan, gebruik een scherpe boor en oefen bij het boren weinig druk uit!
  - E ¡Utilizar una base de madera!  
¡Presionar el frente, utilizar una broca afilada y taladrar con poca presión!
  - I Utilizzare una base di legno! Appoggiare la facciata, utilizzare una punta di trapano affilata e trapanare esercitando solo una leggera pressione!
  - RUS Использовать деревянную подложку!  
Прижать фасад, использовать острое сверло и просверлить с незначительным давлением!
  - PL Używać podkładkę z drewna!  
Docisnąć front, użyć ostrego wiertła i przewiercić, używając małej siły nacisku!

- H Alkalmazzon fa alátétet!  
Nyomja le az előlapot, használjon éles fúrót, és kis nyomással fúrja át!
- CZ Použijte dřevný podklad!  
Přitlačte čelo, použijte ostrý vrták a provrtejte pomocí malého tlaku!
- SLO Uporabite leseno podlago!  
Pritisnite ličnico ter z ostrim svedom in z majhnim pritiskom izvrtajte luknjol!
- FIN Käytä puualustaa!  
Paina etulevy paikoilleen, käytä terävää poranterää ja poraa reikä vain kevyesti painamalla!
- S Använd ett träunderlag!  
Tryck fronten mot underlaget, använd vass borr och borra igenom med ett lätt tryck!
- SK Použite drevený podklad!  
Přitlačte front, použite ostrý vrták a prevrtajte miernym tlakom!
- RO suport de lemn! Împingeți frontul, utilizați un burghiu ascuțit și perforați exercitând doar o presiune redusă!
- TR Ahşap taban kullanın!  
Önden bastırın, keskin matkap ucu kullanın ve az basınç uygulayarak delin!

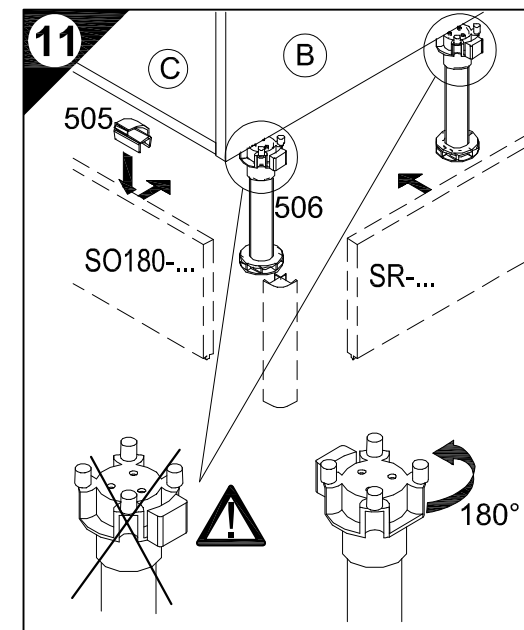
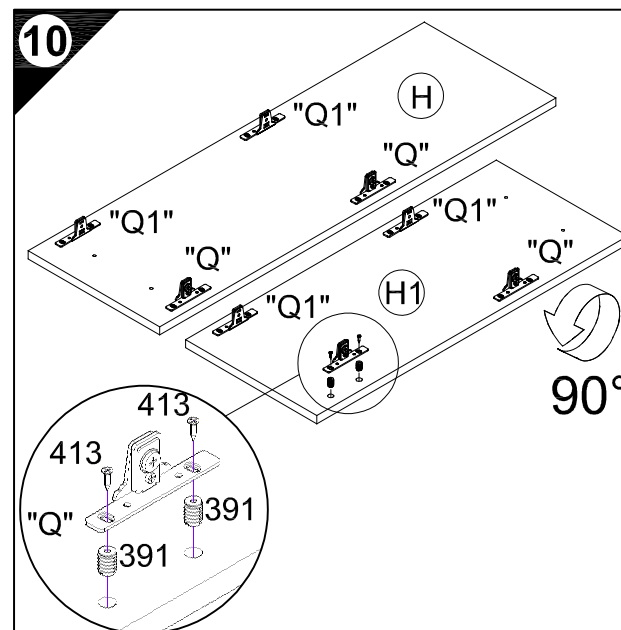
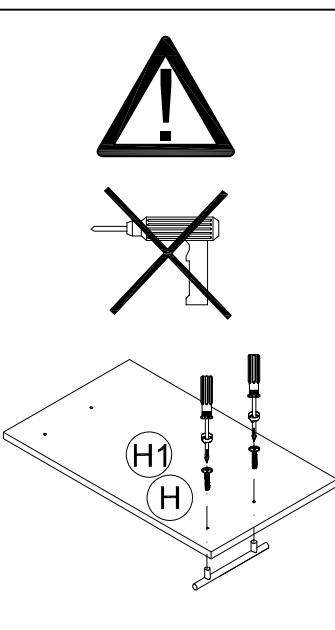

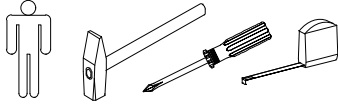

# Montageanleitung

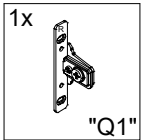
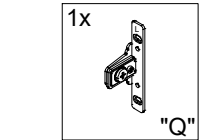
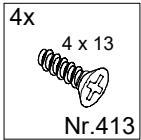
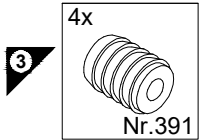
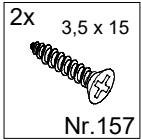
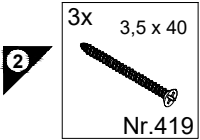
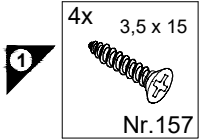
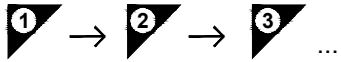
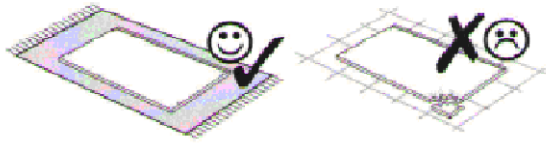

|S| + |S1|

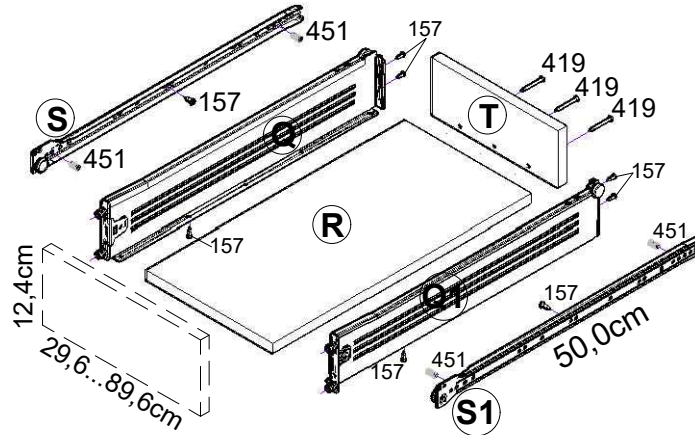
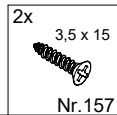
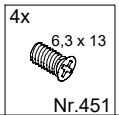

SK30-8E... SK90-8E  
(SK30-H... SK90-H)

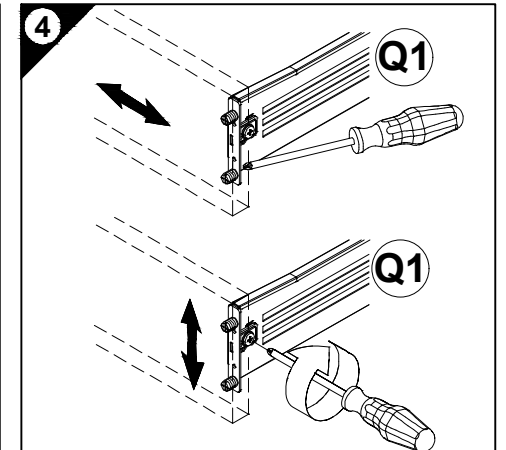
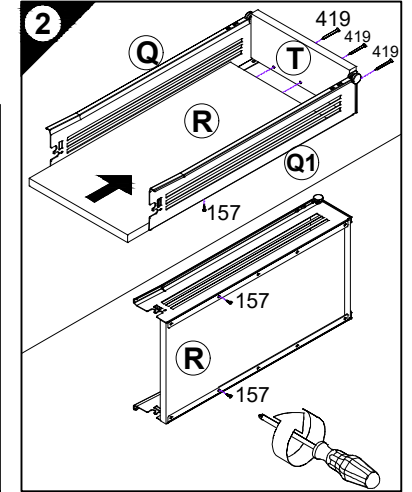
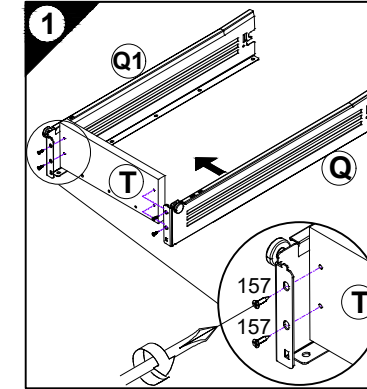
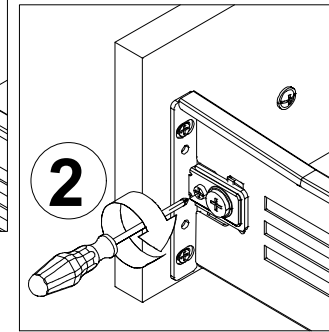
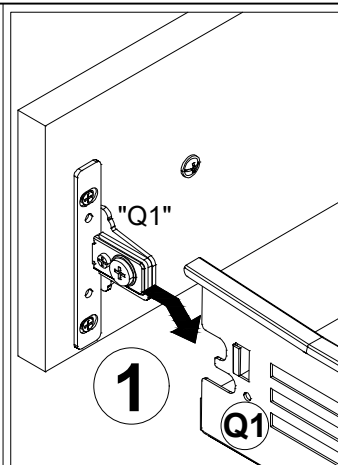
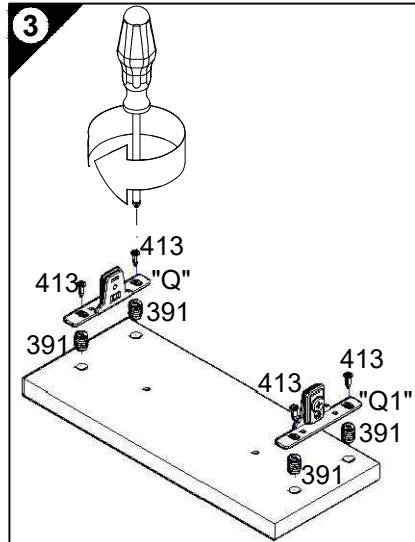

Ersatzteile/Spare parts/pièces de rechange/Reserveonderdelen/Piezas de recambio/Ricambi/Запасные части/Części zamienne/półtaktrészek/Náhradní části/Nadomestni deli/varaosat/reservdelar/náhradné diely/Utilizați piese de schimb/Yedek parçalar

30cm	SK30-8E	Q	E966001	Q1	E966002	R	E941951	S	E966003	S1	E966004	T	E941941
40cm	SK40-8E	Q	E966001	Q1	E966002	R	E941952	S	E966003	S1	E966004	T	E941942
50cm	SK50-8E	Q	E966001	Q1	E966002	R	E941953	S	E966003	S1	E966004	T	E941943
60cm	SK60-8E	Q	E966001	Q1	E966002	R	E941954	S	E966003	S1	E966004	T	E941944
90cm	SK90-8E	Q	E966001	Q1	E966002	R	E941955	S	E966003	S1	E966004	T	E941945

**Service-Hotline**  
01805-678101  
0,14€ pro Min.  
**+49 für Österreich**  
Auslandstarif pro Min.  
**service@jaka-bkl.de**  
voor Nederland en België  
00800-4019350  
benelux@jaka-bkl.de

# Montageanleitung

1 → 2 → 3 ...

- 1**

8x 3,5 x 15  
Nr.157

2x

"V"

**2**

3x 3,5 x 40  
Nr.419

2x 3,5 x 15  
Nr.157

**3**

4x  
Nr.391

4x 4 x 13  
Nr.413

1x  
"Q"

1x  
"Q1"

2x  
"V"

|S| + |S1|

4x 6,3 x 13  
Nr.451

2x 3,5 x 15  
Nr.157

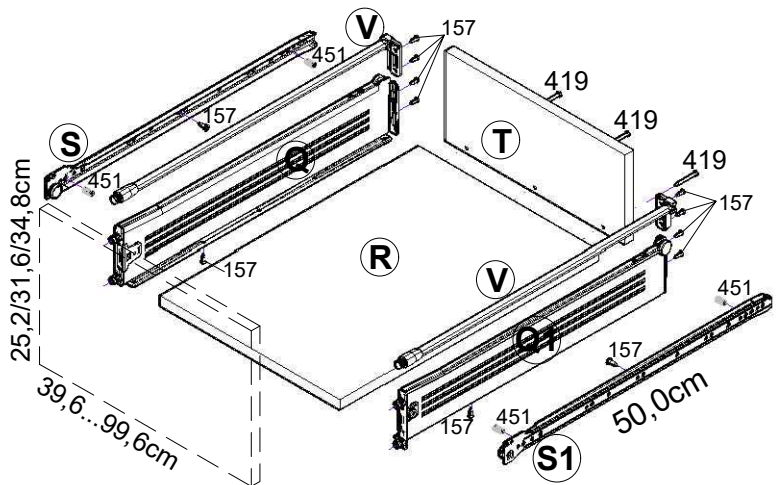

AZ40-8E... AZ100-8E (AZ40-H... AZ100-H)

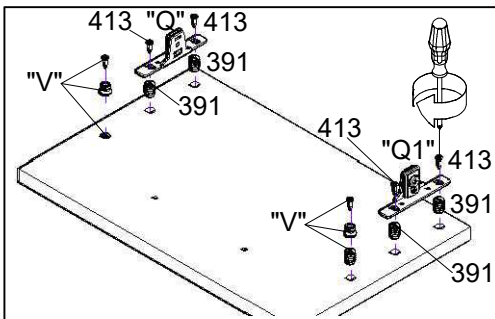
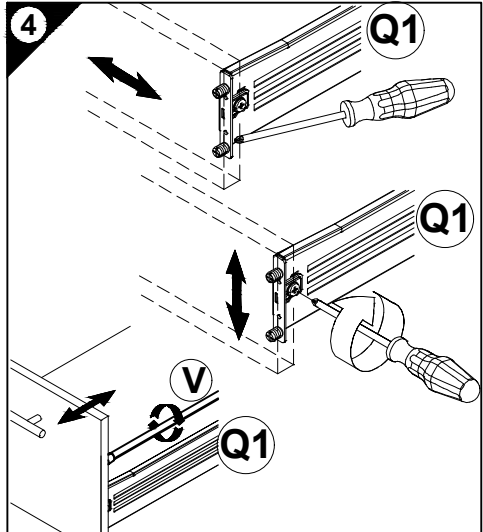
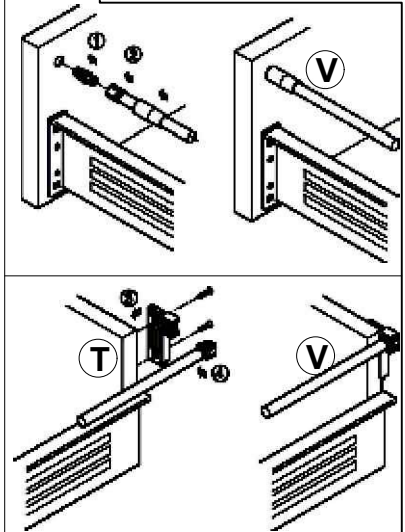
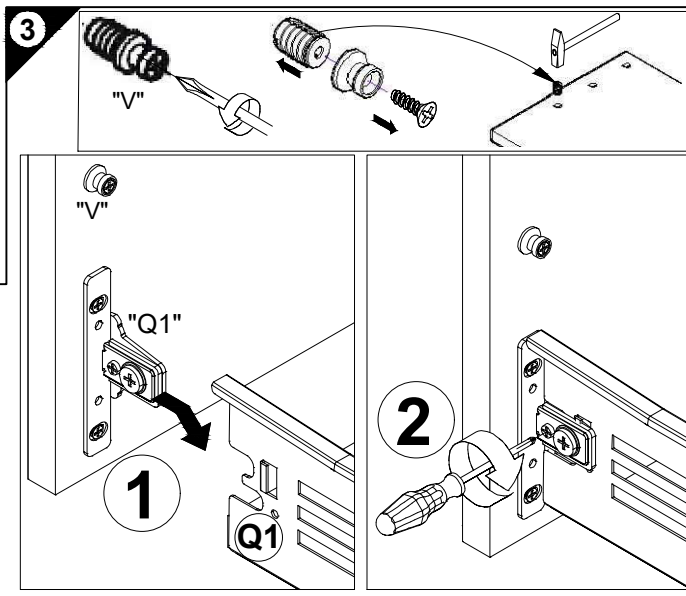
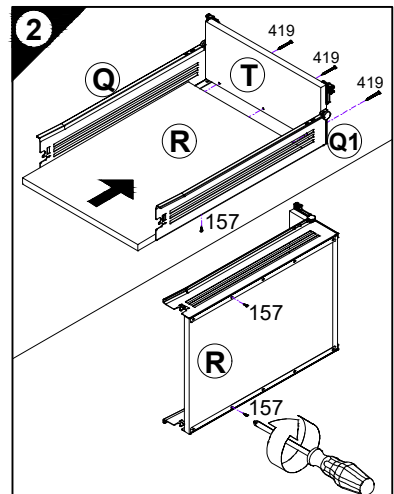
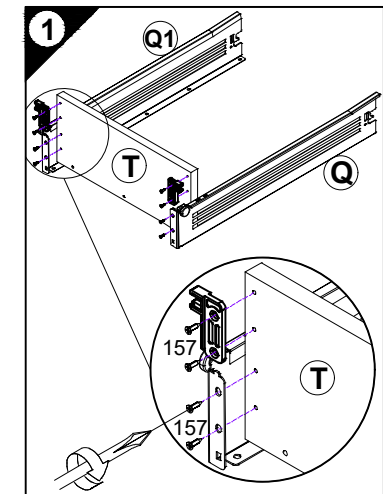

Ersatzteile/Spare parts/pièces de rechange/Reserveonderdelen/Piezas de recambio/Ricambi/Запасные части/Części zamienne/pótkatrészek/Náhradní části/Nadomestni deli/varaosat/reservdelar/náhradné diely/Utilizați piese de schimb/Yedek parçalar

40cm	AZ40-8E	Q  E966001	Q1  E966002	R  E941952	S  E966003	S1  E966004	T  E941946	V  E966005
50cm	AZ50-8E	Q  E966001	Q1  E966002	R  E941953	S  E966003	S1  E966004	T  E941947	V  E966005
60cm	AZ60-8E	Q  E966001	Q1  E966002	R  E941954	S  E966003	S1  E966004	T  E941948	V  E966005
90cm	AZ90-8E	Q  E966001	Q1  E966002	R  E941955	S  E966003	S1  E966004	T  E941949	V  E966005
100cm	AZ100-8E	Q  E966001	Q1  E966002	R  E941956	S  E966003	S1  E966004	T  E941950	V  E966005

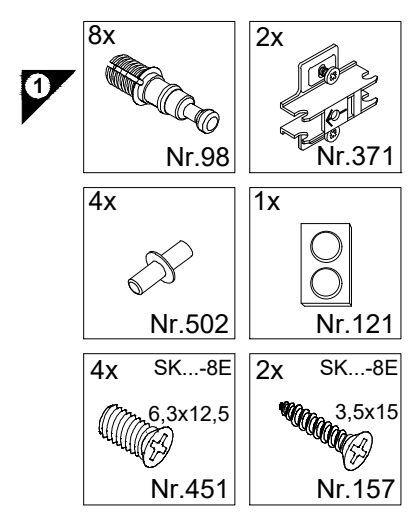
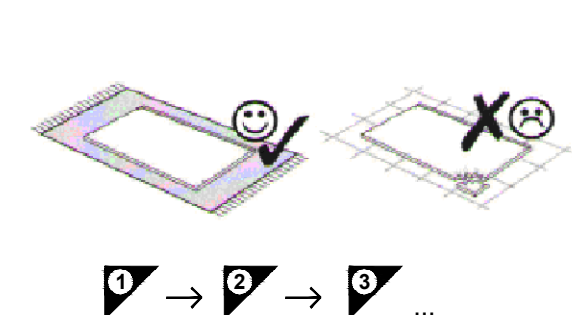
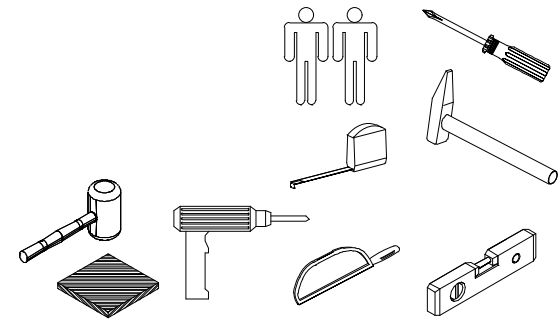

# Montageanleitung

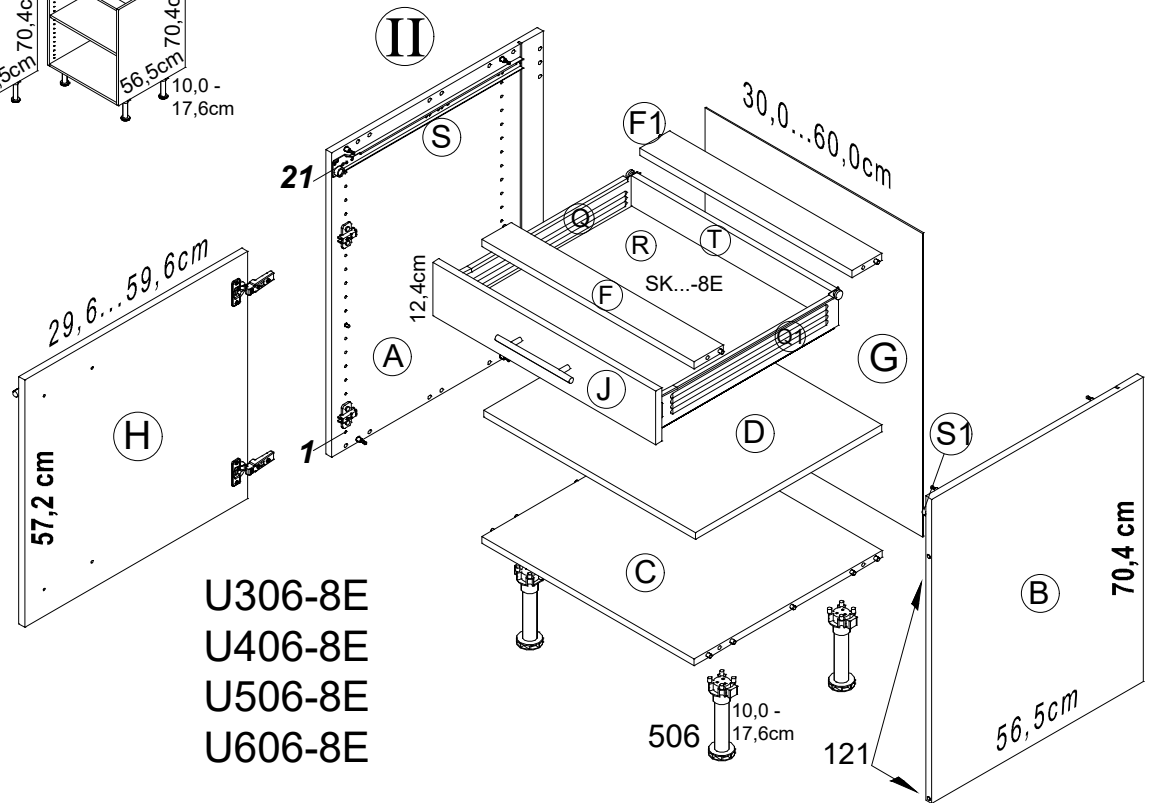
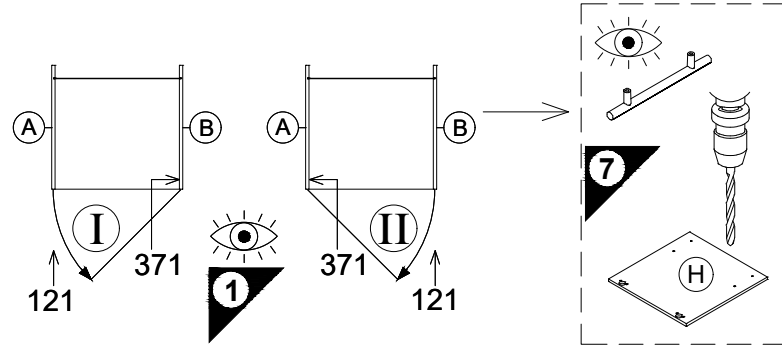
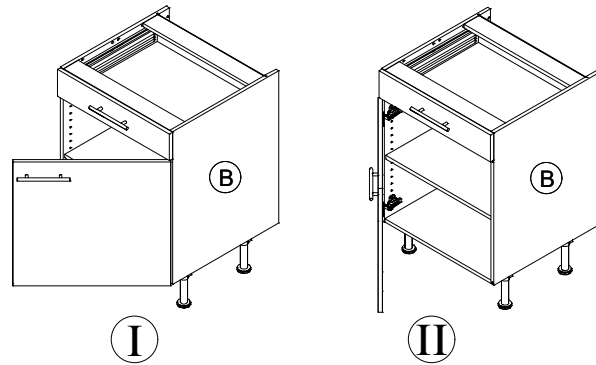
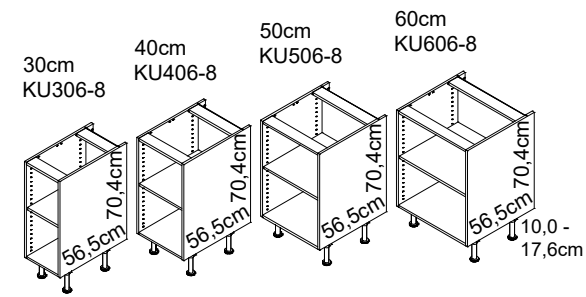

U306-8E  
U406-8E  
U506-8E  
U606-8E

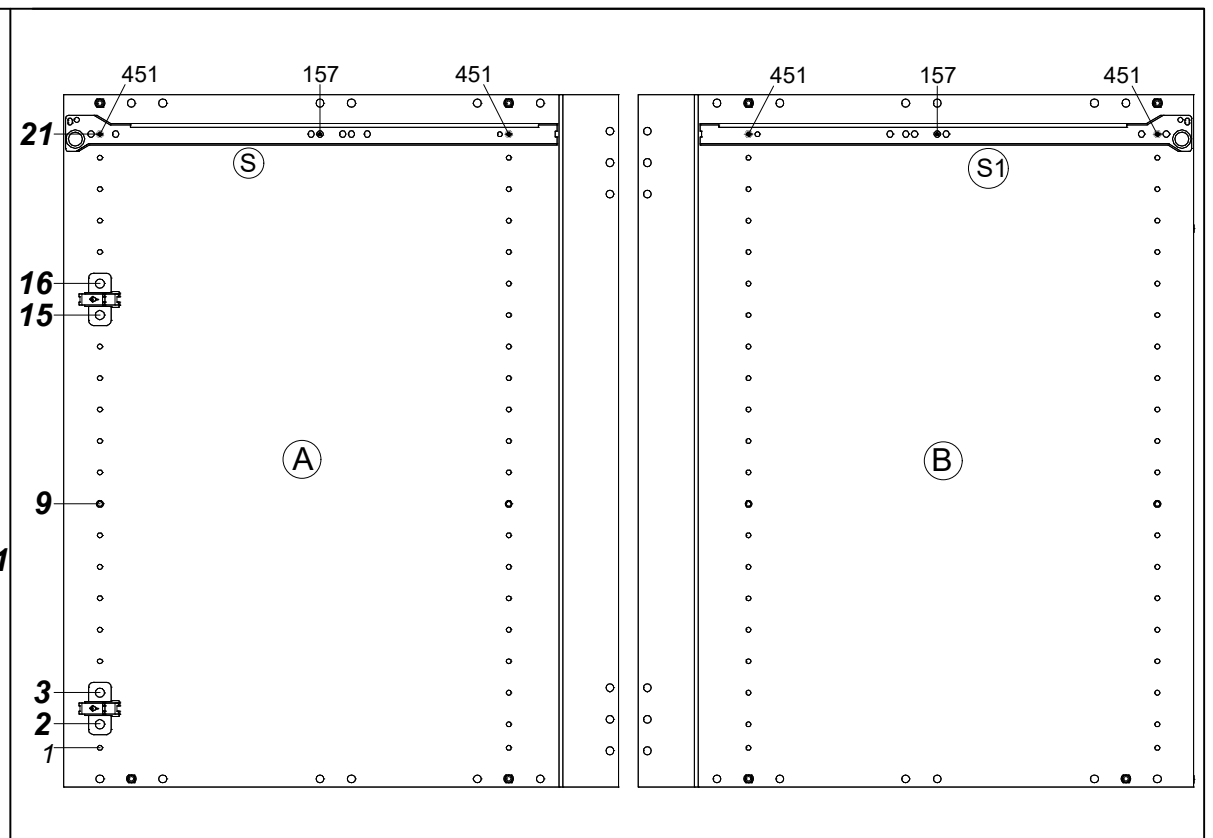
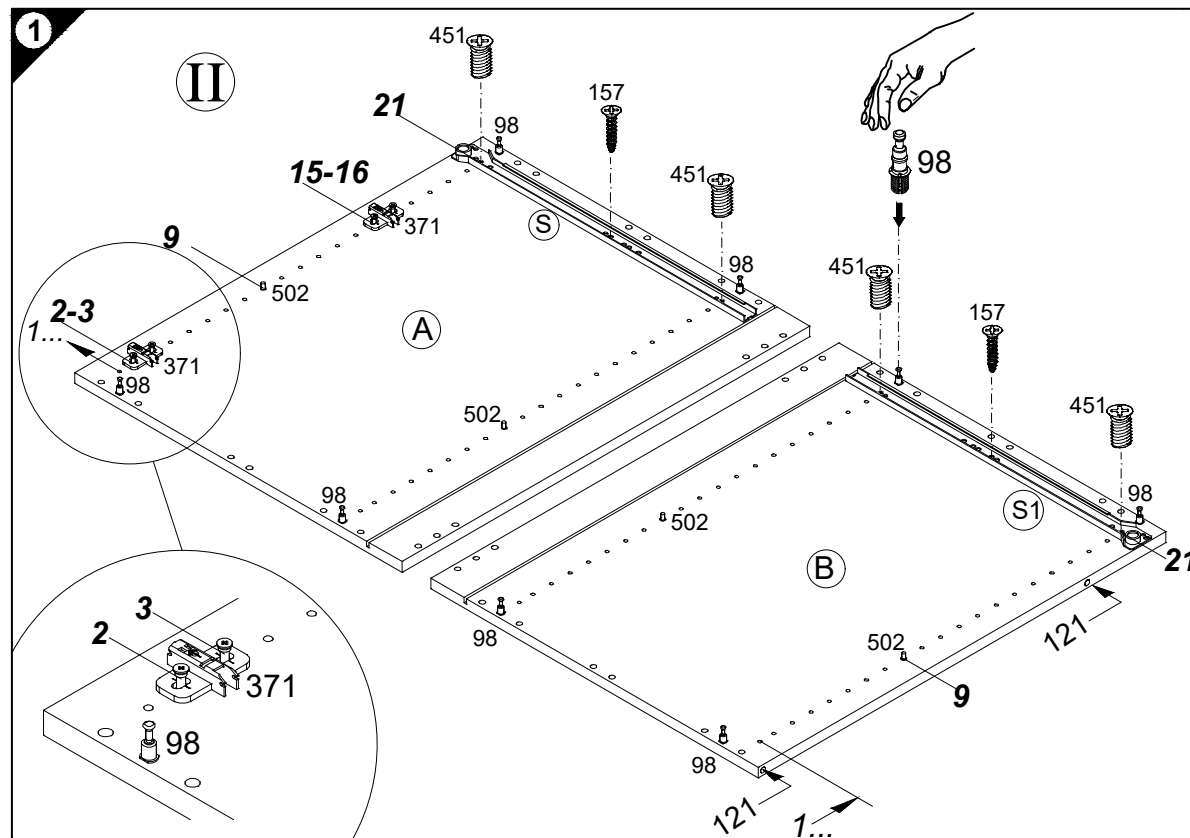

**Service-Hotline**  
**01805-678101**  
0,14€ pro Minute  
**++49 für Österreich**  
Auslandstarif pro Minute  
**service@jaka-bkl.de**  
voor Nederland en België  
**00800-40119350**  
**benelux@jaka-bkl.de**

Ersatzteile/Spare parts/pièces de rechange/Reserveonderdelen/Piezas de recambio/Ricambi/Запасные части/Części zamienne/pótalkatrészek/Náhradní části/Nadomestni deli/varaosat/reservdelar/náhradné diely/Utilizați piese de schimb/Yedek parçalar

U 306-8E	A  E941021	B  E941021	C  E951216	D  E950306	F  E942976	F1  E952976	G  E970006	H  E940614	J  E940565	Q  E966001	Q1  E966002	R  E941951	S  E966003	S1  E966004	T  E941941
U 406-8E	A  E941021	B  E941021	C  E951215	D  E950305	F  E942975	F1  E952975	G  E970010	H  E940613	J  E940564	Q  E966001	Q1  E966002	R  E941952	S  E966003	S1  E966004	T  E941942
U 506-8E	A  E941021	B  E941021	C  E951224	D  E950304	F  E942974	F1  E952974	G  E970117	H  E940612	J  E940563	Q  E966001	Q1  E966002	R  E941953	S  E966003	S1  E966004	T  E941943
U 606-8E	A  E941021	B  E941021	C  E951223	D  E950303	F  E942973	F1  E952973	G  E970116	H  E940611	J  E940562	Q  E966001	Q1  E966002	R  E941954	S  E966003	S1  E966004	T  E941944



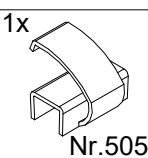
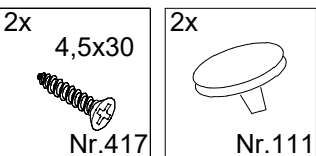
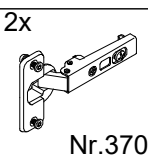
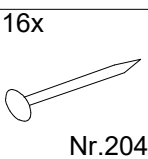
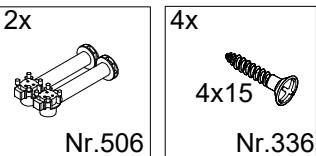
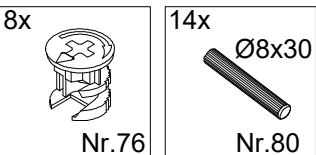
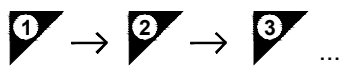

100-176mm

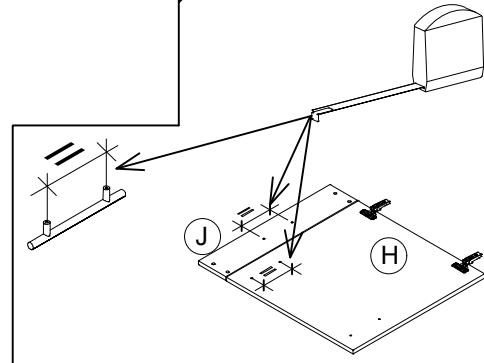
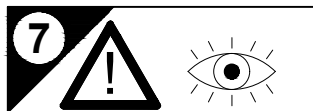
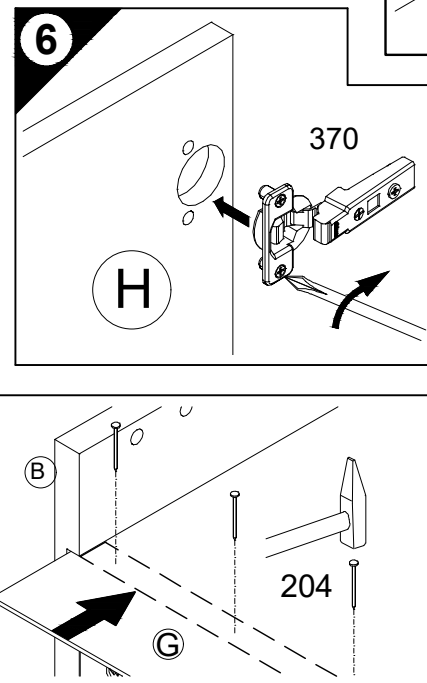
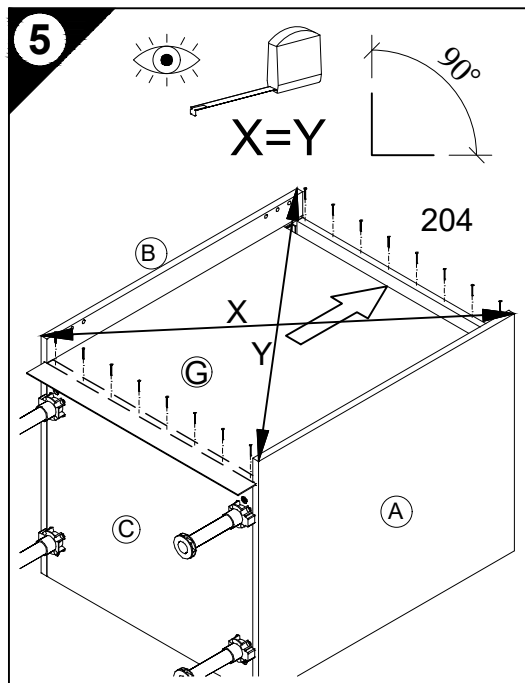
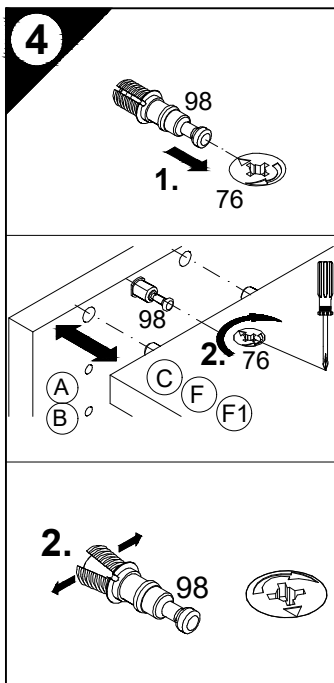
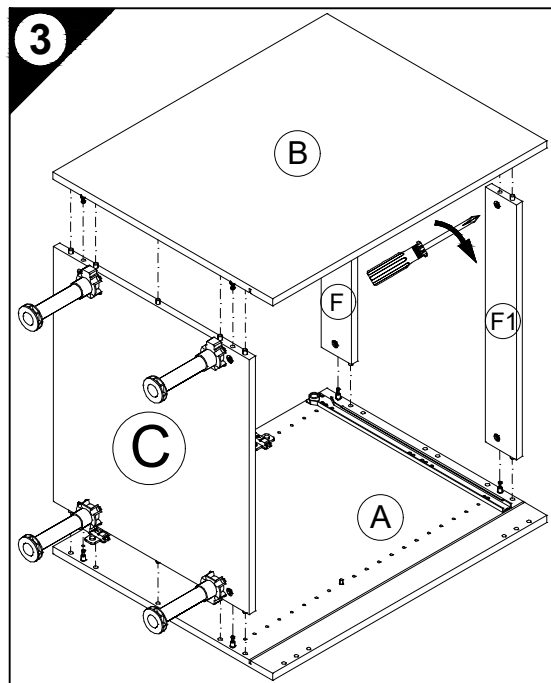
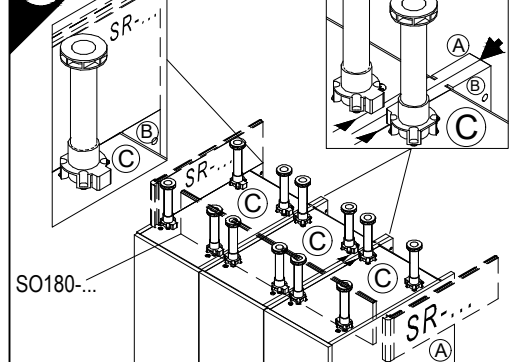
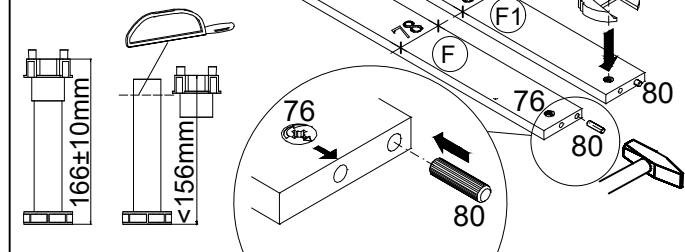

D Holzunterlage verwenden!  
Front andrücken, scharfen Bohrer verwenden und mit wenig Druck durchbohren!  
GB Use a wooden base!  
Press front down, use sharp drill bit and, by applying slight pressure, drill a hole  
Utiliser un support en bois!  
F Appuyer sur la façade, utiliser un foret bien affûté et percer en appliquant une faible pression!  
NL Houlen onderlegger gebruiken!  
Druk het front aan, gebruik een scherpe boor en oefen bij het boren weinig druk uit!  
E ¡Utilizar una base de madera!  
¡Presionar el frente, utilizar una broca afilada y taladrar con poca presión!  
I Utilizzare una base di legno!  
Appoggiare la facciata, utilizzare una punta di trapano affilata e trapanare esercitando solo una leggera pressione!  
RUS Использовать деревянную подложку!  
Прижать фасад, использовать острое сверло и просверлить с незначительным давлением!  
PL Używać podkładkę z drewna!  
Docisnąć front, używając ostrego wiertła i przewiercić, używając małej siły nacisku!

H Alkalmazzon fa alátétet!  
Nyomja le az előlapot, használjon éles fúrót, és kis nyomással fúrja át!  
CZ Použijte dřevěný podklad!  
Přitlačte čelo, použijte ostrý vrták a prověřte pomocí malého tlaku!  
SLO Uporabite leseno podlago!  
Pritisnite ličnico ter z ostrim svedrom in z majhnim pritiskom izvrtajte luknjno!  
FIN Käytä puualustaa!  
Paina etulevy paikoilleen, käytä terävää poranterää ja poraa reikä vain kevyesti painamalla!  
S Använd ett träunderlag!  
Tryck fronten mot underlaget, använd vass borr och borra igenom med ett lätt tryck!  
SK Použite drevený podklad!  
Přitlačte front, použite ostrý vrták a prevěřte miernym tlakom!  
RO suport de lemn!  
Împingeți frontul, utilizați un burghiu ascuțit și perforați exercitând doar o presiune redusă!  
TR Ahşap taban kullanın!  
Önden bastırın, keskin matkap ucu kullanın ve az basınç uygulayarak delin!

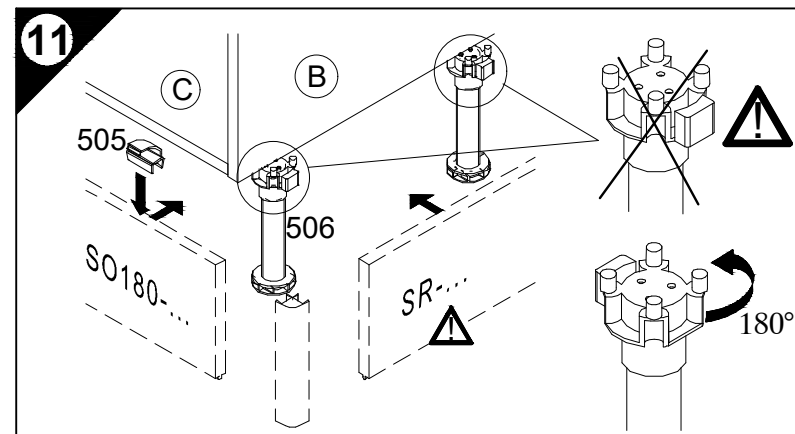
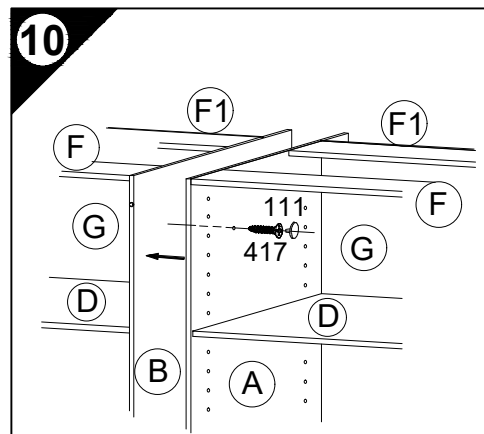
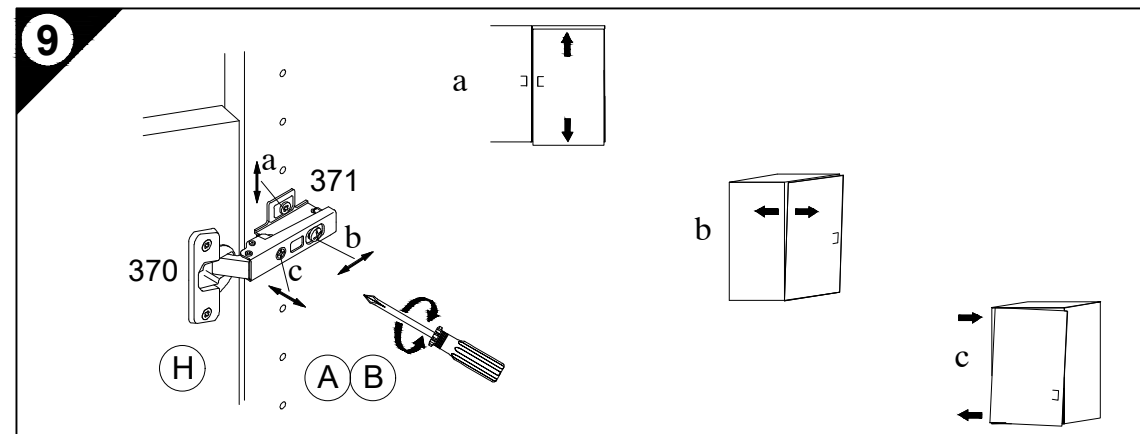
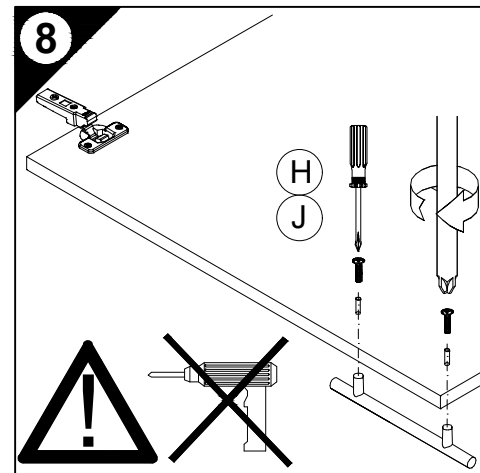

E 948031

Als Zubehör erhältlich  
Available as an accessory  
Disponible en accessoire  
Verkrijgbaar als accessoire  
Se puede obtener como accesorio  
Disponibile come accessorio  
продаётся как принадлежность  
Dostępna jako dodatkowe wyposażenie  
Tartozékként kapható  
k dodání jako příslušenství  
Dobavljivo kot dodatna oprema  
Lisävaruste  
Kan levereras som tillbehör  
Dostupné ako príslušenstvo  
Disponibil ca accesoriu  
Aksesuar olarak temin alınabilir

D Die äußeren Schränke von miteinander zu einer Zeile verbundenen beliebigen Anzahl von Unterschränken, sowie einzeln stehende Unterschränke müssen mit Wandbefestigungswinkeln versehen werden.  
GB The outer cabinets must be fitted with wall mounting brackets if a row of any number of base units or individual base units are to be connected together.  
F Les armoires extérieures de tous meubles bas montés en ligne doivent être munies d'équerres de fixation murale. Il en va de même pour les meubles bas indépendants.  
NL De buitenste kasten van met elkaar tot een rij verbonden willekeurig aantal onderkasten, evenals apart staande onderkasten, moeten van wandbevestigingsbeugels worden voorzien.  
E Los armarios inferiores de los extremos, de una línea de módulos inferiores cuantos se deseen, deberán ser fijados a la pared con escuadras de fijación mural, así como los armarios inferiores que se monten aislados de forma independiente.  
I I mobili esterni al pari dei lavabi sparsi devono essere dotati di staffe di fissaggio a muro, se un numero qualsiasi di sottolavabi viene collegato l'uno con l'altro in una fila.  
RUS Если несколько напольных шкафов соединено вместе в единую секцию, то крайние шкафы следует привинтить к стене уголками. Отдельно стоящие напольные шкафы также следует крепить к стене уголками.  
PL Jeżeli dolne szafki połączone są ze sobą w szereg, to w uchwyt ściennie należy wyposażyć szafki zewnętrzne. Pojedyncze, wolnostojące dolne szafki, również należy wyposażyć w uchwyt.  
H A tetszőleges számú, egymáshoz rögzített alsó szekrényekből álló sor szélső szekrényeit, valamint a különálló alsó szekrényeket fali rögzítő profillal kell elátni.  
CZ Ke stěně je nutno úhelníkem připevnit samostatně stojící skříně a u vnější skříně, pokud jsou spolu s dalšími skříněmi spojeny v jedné řadě.  
SLO Zunanje omare se morajo pričvrstiti s pritrilnimi zidnimi kotniki, kadar se povezujejo v eno linijo s poljubnim številom spodnjih omaric. Prav tako, se morajo prostostoječe spodnje omare, pričvrstiti s pritrilnimi zidnimi kotniki.  
FIN Aikaapeista muodostuvan kaappirivin uloimmat kaapit on varustettava seinäänkiinnityskulmilla, samoin kuin yksittäiskaapitkin.  
S De yttre skåpen måste förseas med väggfästevinkel när ett valfritt antal underskåp förbinds till en rad. Även separat stående underskåp måste förseas med väggfästevinkel.  
SK Na vonkajšie skrinky ľubovoľného počtu spodných skriniek spojených do jedného radu, ako aj na samostatne stojace skrinky je potrebné namontovať nástenný uholník.  
RO Părțile exterioare ale dulapurilor inferioare, indiferent de numărul lor, care sunt legate între ele într-un șir, precum și dulapurile inferioare individuale trebuie prevăzute cu corniere pentru fixarea de perete.  
TR Bir hat halinde birbirine bağlanmış olan çeşitli sayıdaki alt dolapların dış bölümünde kalan dolaplar, tek başına duran alt dolaplar, duvar sabitleme köşebentleri ile duvara bağlanmalıdır.

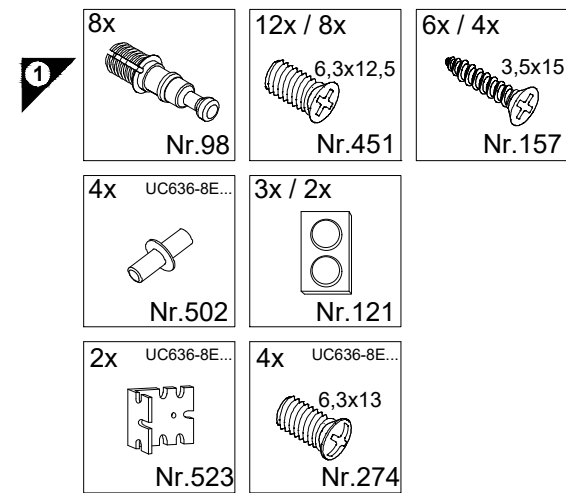
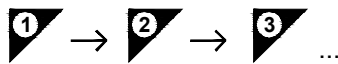
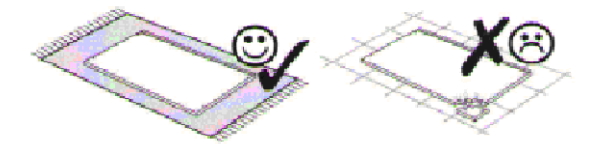
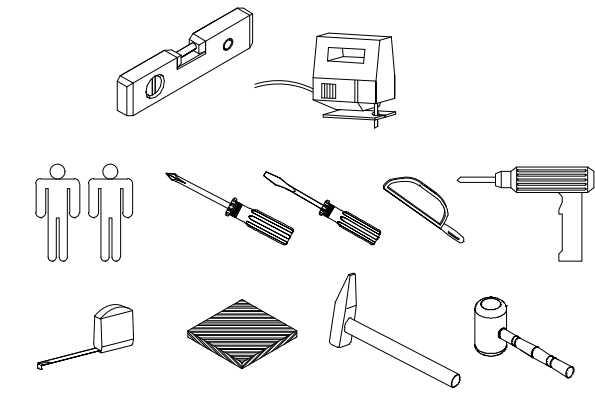

# Montageanleitung

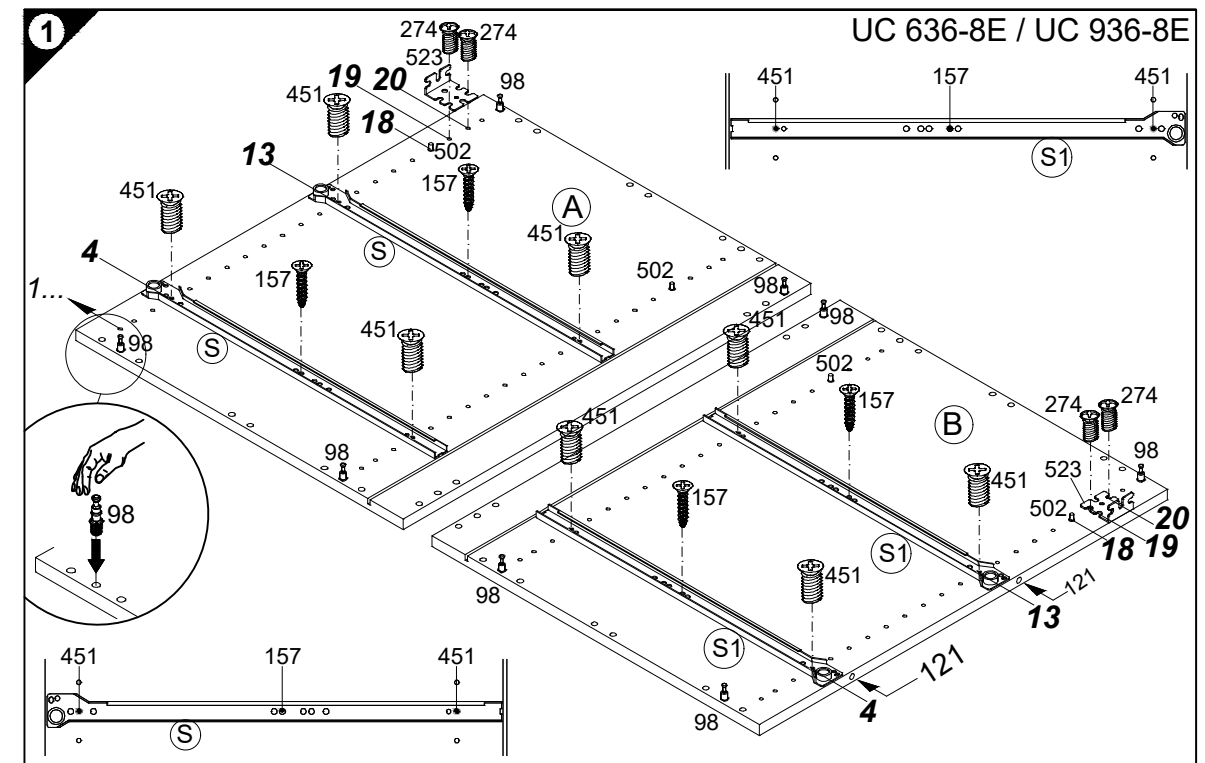
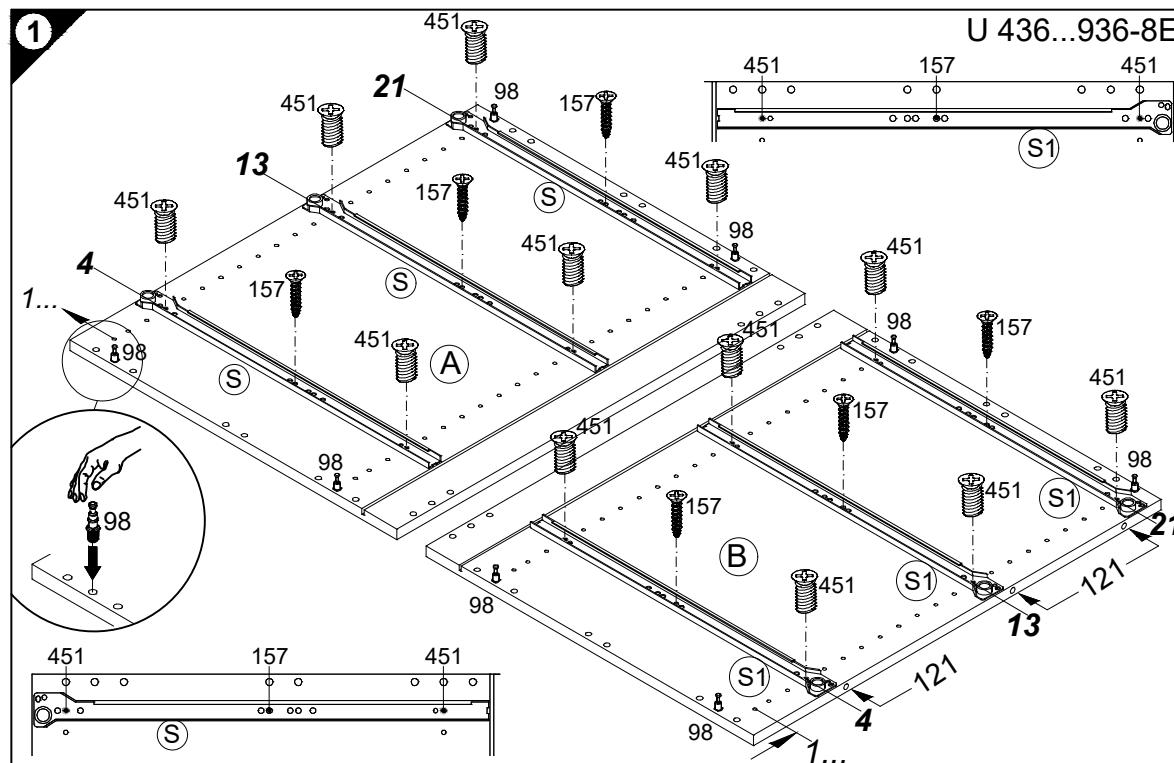
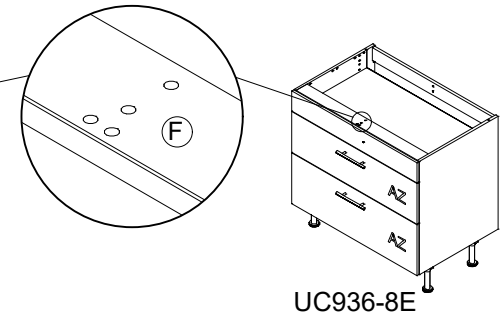
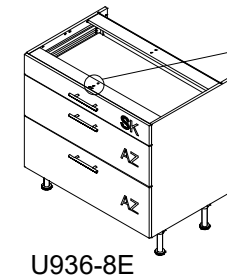
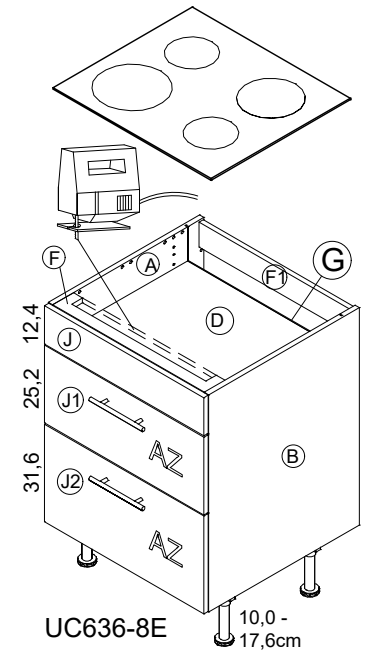
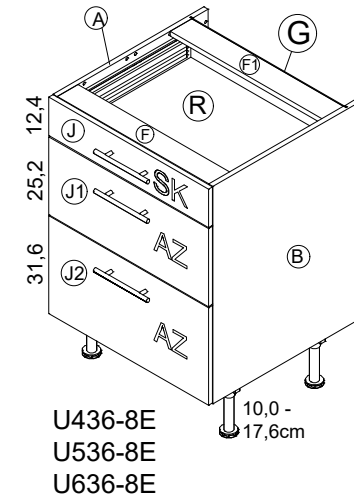
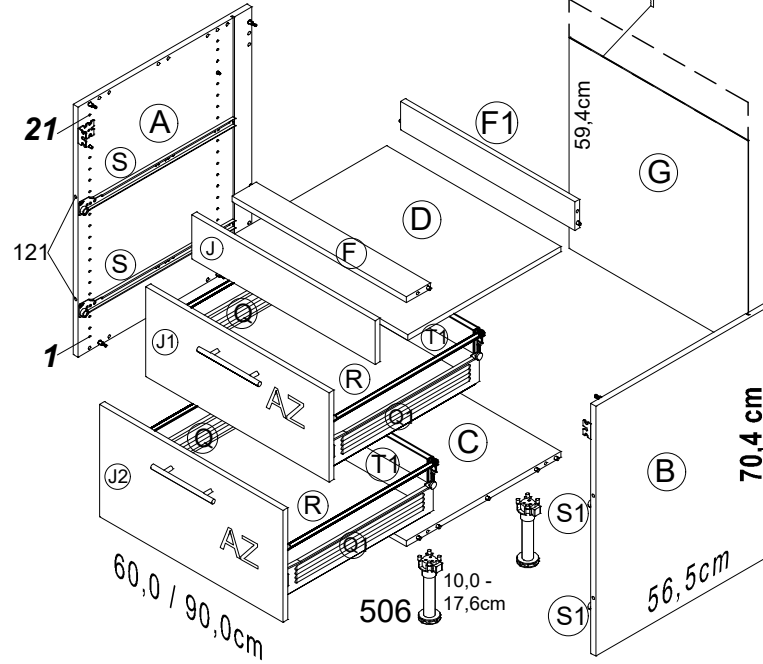
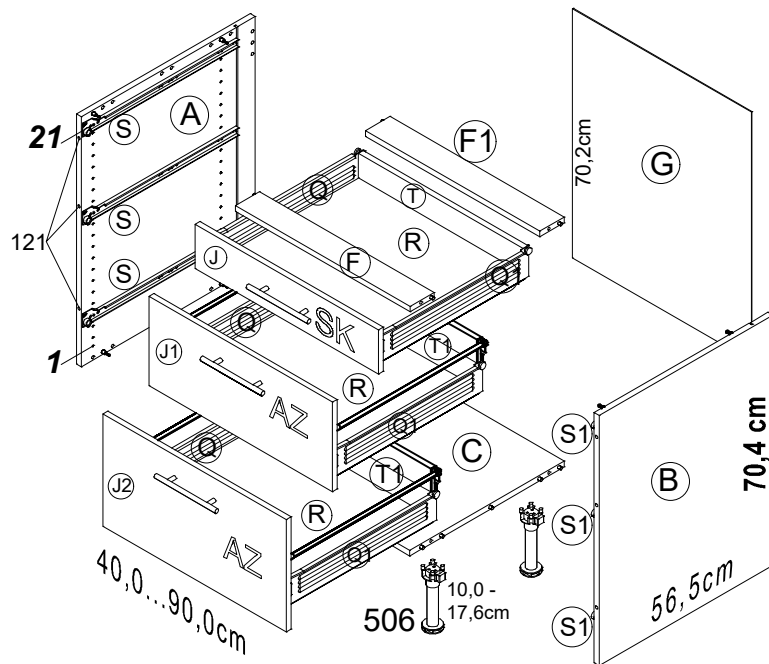
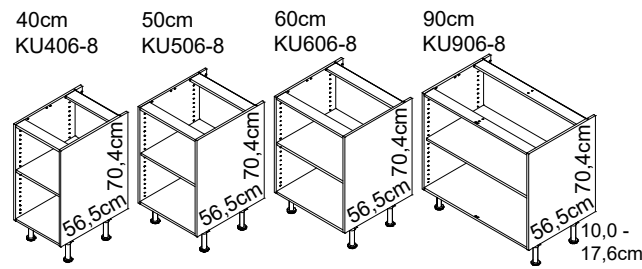

**Service-Hotline**  
01805-678101  
0,14€ pro Minute  
**++49 für Österreich**  
Auslandstarif pro Minute  
**service@jaka-bkl.de**  
voor Nederland en België  
**00800-40119350**  
**benelux@jaka-bkl.de**

Ersatzteile/Spare parts/pièces de rechange/Reserveonderdelen/Piezas de recambio/Ricambi/Запасные части/Części zamienne/pótalkatrészek/Náhradní části/Nadomestni deli/varaosat/reservdelar/náhradné diely/Utilizați piese de schimb/Yedek parçalar

40cm U 436-8E	A  E941021	B  E941021	C  E951215	F  E942975	F1  E952975	G  E970010	J  E940564	J1  E940593	J2  E940643	Q  E966001	Q1  E966002	R  E941952	S  E966003	S1  E966004	T  E941942	T1  E941946	V  E966005
50cm U 536-8E	A  E941021	B  E941021	C  E951224	F  E942974	F1  E952974	G  E970117	J  E940563	J1  E940592	J2  E940644	Q  E966001	Q1  E966002	R  E941953	S  E966003	S1  E966004	T  E941943	T1  E941947	V  E966005
60cm U 636-8E	A  E941021	B  E941021	C  E951223	F  E942973	F1  E952973	G  E970116	J  E940562	J1  E940591	J2  E940645	Q  E966001	Q1  E966002	R  E941954	S  E966003	S1  E966004	T  E941944	T1  E941948	V  E966005
90cm U 936-8E	A  E941021	B  E941021	C  E951218	F  E942978	F1  E952978	G  E970072	J  E940675	J1  E940674	J2  E940672	Q  E966001	Q1  E966002	R  E941955	S  E966003	S1  E966004	T  E941945	T1  E941949	V  E966005
60cm UC 636-8E	A  E941021	B  E941021	C  E951223	D  E950303	F  E942973	F1  E952973	G  E970116	J  E940562	J1  E940591	J2  E940645	Q  E966001	Q1  E966002	R  E941954	S  E966003	S1  E966004	T1  E941948	V  E966005
90cm UC 936-8E	A  E941021	B  E941021	C  E951218	D  E950312	F  E942978	F1  E952978	G  E970072	J  E940675	J1  E940674	J2  E940672	Q  E966001	Q1  E966002	R  E941955	S  E966003	S1  E966004	T1  E941949	V  E966005

1 → 2 → 3 ...

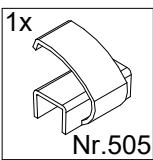
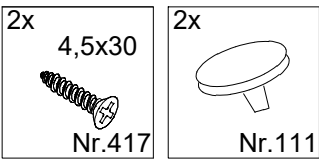
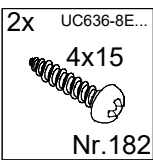
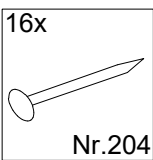
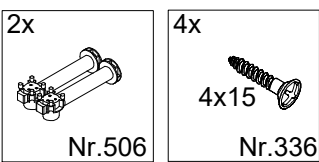
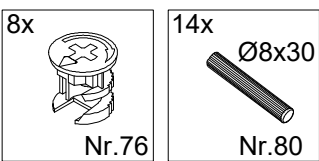

2a

100-176mm

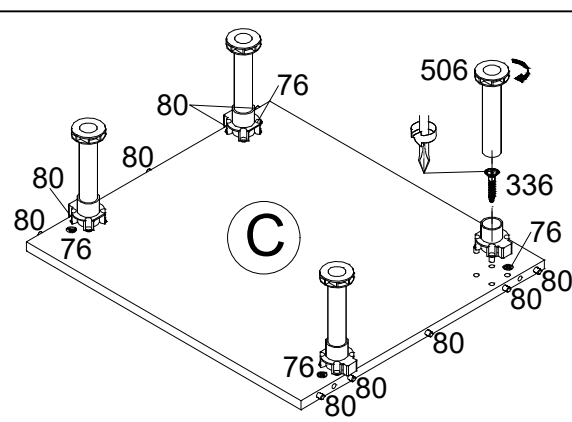
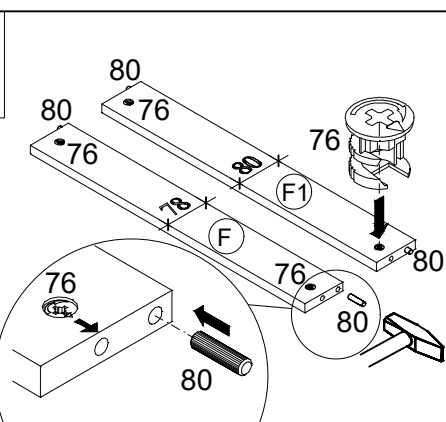
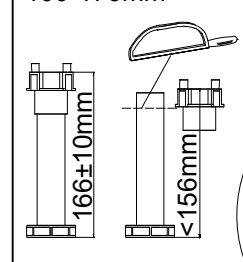

2b

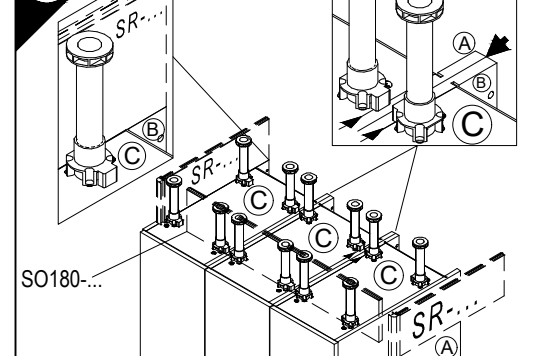

E 948031

Als Zubehör erhältlich  
Available as an accessory  
Disponibile en accessoire  
Verkrijgbaar als accessoire  
Se puede obtener como accesorio  
Disponibile come accessorio  
продаётся как принадлежность  
Dostępna jako dodatkowe wyposażenie  
Tartozékként kapható  
k dodání jako příslušenství  
Dobavljivo kot dodatna oprema  
Lisävaruste  
Kan levereras som tillbehör  
Dostupné ako príslušenstvo  
Disponibil ca accesorii  
Aksesuar olarak temin alınabilir

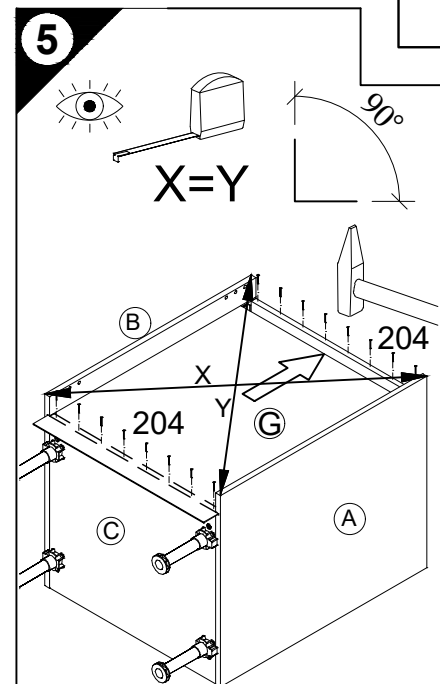
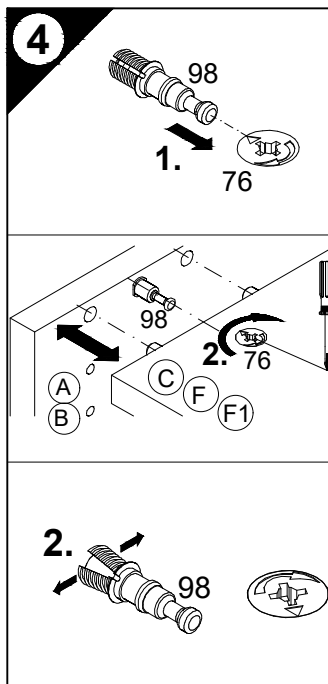
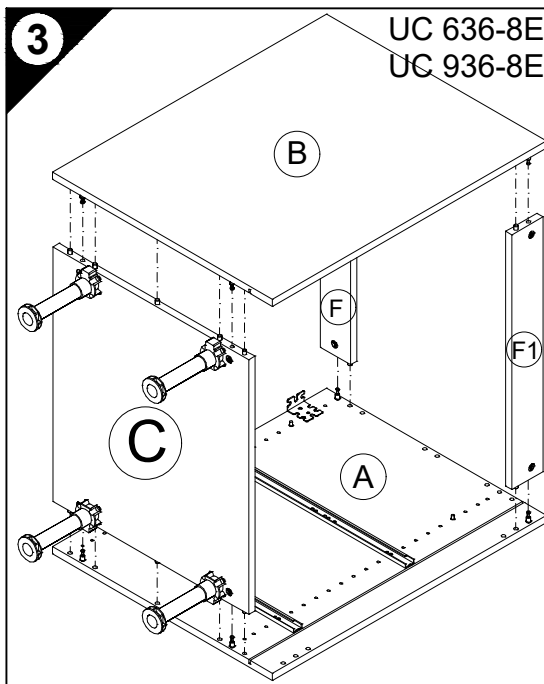
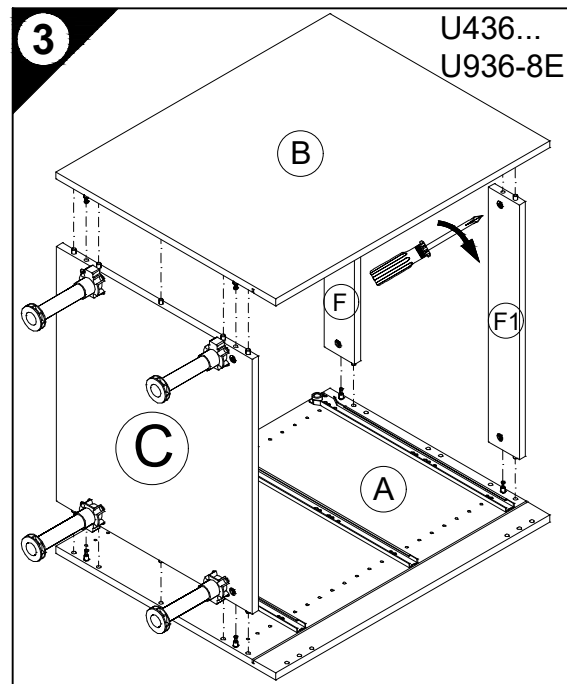

D Die äußeren Schränke von miteinander zu einer Zeile verbundenen beliebigen Anzahl von Unterschränken, sowie einzeln stehende Unterschränke müssen mit Wandbefestigungswinkeln versehen werden.

GB The outer cabinets must be fitted with wall mounting brackets if a row of any number of base units or individual base units are to be connected together.

F Les armoires extérieures de tous meubles bas montés en ligne doivent être munies d'équerres de fixation murale. Il en va de même pour les meubles bas indépendants.

NL De buitenste kasten van met elkaar tot een rij verbonden willekeurig aantal onderkasten, evenals apart staande onderkasten, moeten van wandbevestigingsbeugels worden voorzien.

E Los armarios inferiores de los extremos, de una línea de módulos inferiores cuantos se deseen, deberán ser fijados a la pared con escuadras de fijación mural, así como los armarios inferiores que se monten aislados de forma independiente.

I I mobili esterni al pari dei lavabi sparsi devono essere dotati di staffe di fissaggio a muro, se un numero qualsiasi di sottolavabi viene collegato l'uno con l'altro in una fila.

RUS Если несколько напольных шкафов соединено вместе в единую секцию, то крайние шкафы следует привинтить к стене уголками. Отдельно стоящие напольные шкафы также следует крепить к стене уголками.

PL Jeżeli dolne szafki połączone są ze sobą w szereg, to w uchwyt ścienne należy wyposażyć szafki zewnętrzne. Pojedyncze, wolnostojące dolne szafki, również należy wyposażyć w uchwyty.

H A tetszöleges számú, egymáshoz rögzített alsó szekrényekből álló sor szélső szekrényeit, valamint a különálló alsó szekrényeket fali rögzítő profilal kell ellátni.

CZ Ke stěně je nutno ušelnikem připevnit samostatně stojící skřínky a vnější skřínky, pokud jsou spolu s dalšími skřínkami spojeny v jedné řadě.

SLO Zunanje omare se morajo pričvrstiti s pritrdilnimi zidnimi kotniki, kadar se povezujejo v eno linijo s poljubnim številom spodnjih omaric. Prav tako, se morajo prostostoječe spodnje omare, pričvrstiti s pritrdilnimi zidnimi kotniki.

FIN Aikaapeista muodostuvan kaappirivin uloimmat kaapit on varustettava seinäänkiinnityskulmilla, samoin kuin yksittäiskaapitkin.

S De yttre skåpen måste förseas med väggfästevinkel när ett valfritt antal underskåp förbinds till en rad. Även separat stående underskåp måste förseas med väggfästevinkel.

SK Na vonkajšie skrinky ľubovoľného počtu spodných skriniek spojených do jedného radu, ako aj na samostatne stojace spodné skrinky je potrebné namontovať nástenný uholník.

RO Părțile exterioare ale dulapurilor inferioare, indiferent de numărul lor, care sunt legate între ele într-un șir, precum și dulapurile inferioare individuale trebuie prevăzute cu corniere pentru fixarea de perete.

TR Bir hat halinde birbirine bağlanmış olan çeşitli sayıdaki alt dolapların dış bölümlünde kalan dolaplar, tek başına duran alt dolaplar, duvar sabitleme köşebentleri ile duvara bağlanmalıdır.

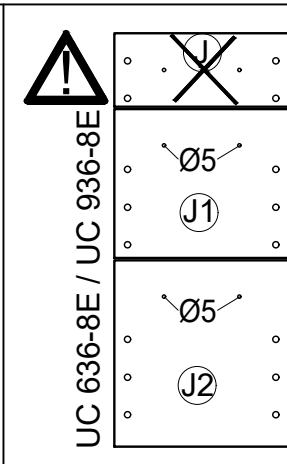
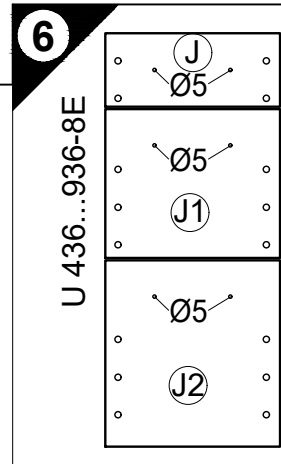
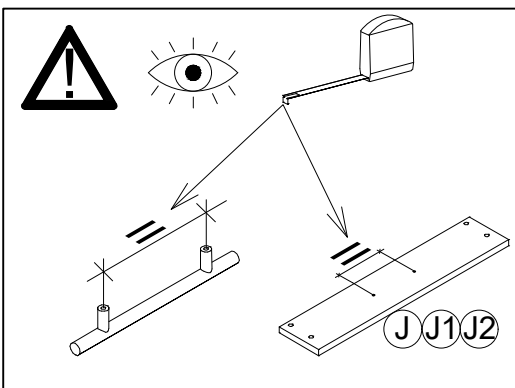

D Holzunterlage verwenden!  
Front andrücken, scharfen Bohrer verwenden und mit wenig Druck durchbohren!

GB Use a wooden base!  
Press front down, use sharp drill bit and, by applying slight pressure, drill a hole

F Utiliser un support en bois!  
Appuyer sur la façade, utiliser un foret bien affûté et percer en appliquant une faible pression!

NL Houten onderlegger gebruiken!  
Druk het front aan, gebruik een scherpe boor en oefen bij het boren weinig druk uit!

E ¡Utilizar una base de madera!  
¡Presionar el frente, utilizar una broca afilada y taladrar con poca presión!

I Utilizzare una base di legno!  
Appoggiare la facciata, utilizzare una punta di trapano affilata e trapanare esercitando solo una leggera pressione!

RUS Использовать деревянную подложку!  
Прижать фасад, использовать острое сверло и просверлить с незначительным давлением!

PL Używać podkładkę z drewna!  
Docisnąć front, użyć ostrego wiertła i przewiercić, używając małej siły nacisku!

H Alkalmazzon fa alátét!  
Nyomja le az előlapot, hasznájon éles fúró, és kis nyomással fúrja át!

CZ Použijte dřevěný podklad!  
Přitlačte čelo, použijte ostrý vrták a provrtajte pomocí malého tlaku!

SLO Uporabite leseno podlago!  
Pritisnite ličnico ter z ostrim svedrom in z majhnim pritiskom izvrtajte luknjol!

FIN Käytä puualustaa!  
Paina etulevy paikoilleen, käytä terävää poranterää ja poraa reikä vain kevyesti painamalla!

S Använd ett träunderlag!  
Tryck fronten mot underlaget, använd vass borrh och borra igenom med ett lätt tryck!

SK Použijte drevený podklad!  
Přitlačte front, použijte ostrý vrták a prevrtajte miernym tlakom!

RO suport de lemn!  
Împingeți frontul, utilizați un burghiu ascuțit și perforați exercitând doar o presiune redusă!

TR Ahşap taban kullanın!  
Önden bastırın, keskin matkap ucu kullanın ve az basınç uygulayarak delin!

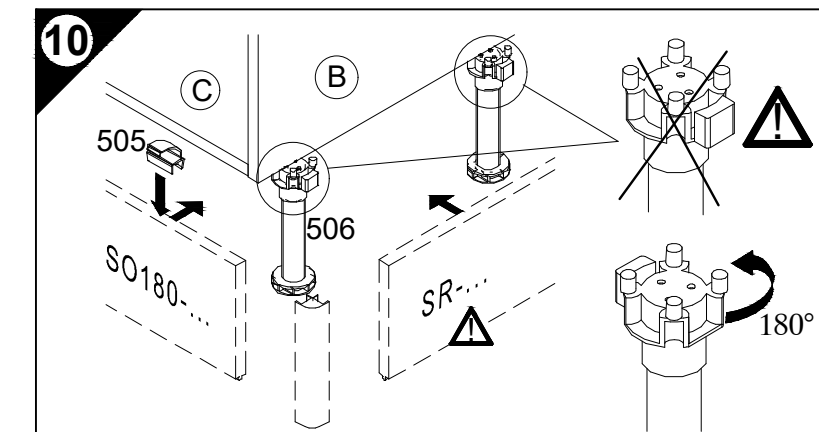
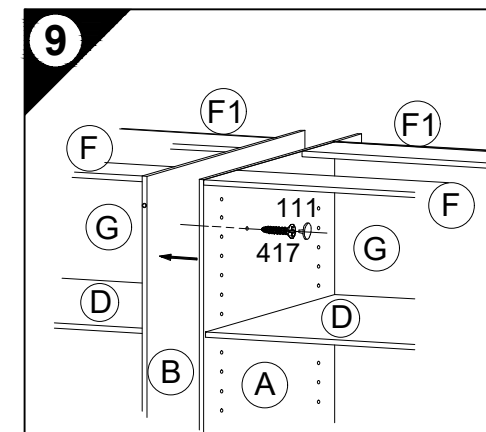
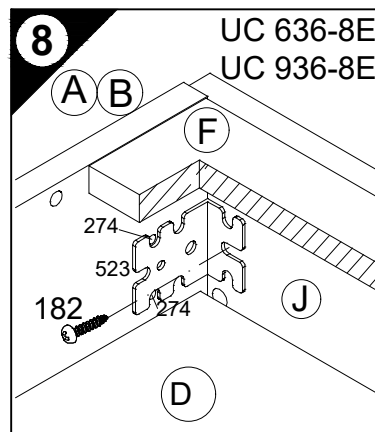
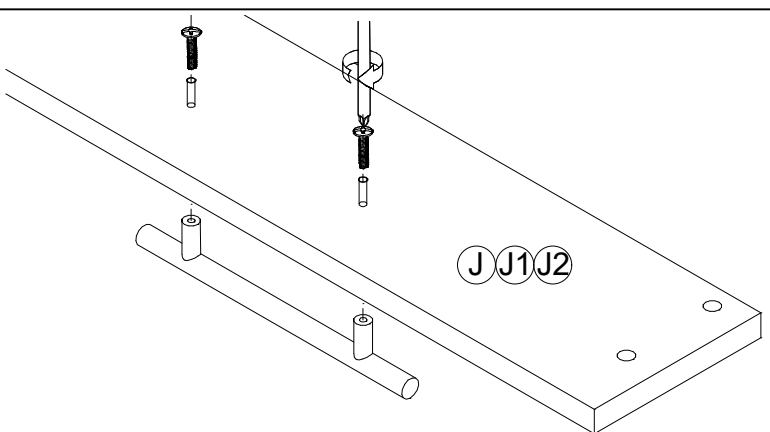
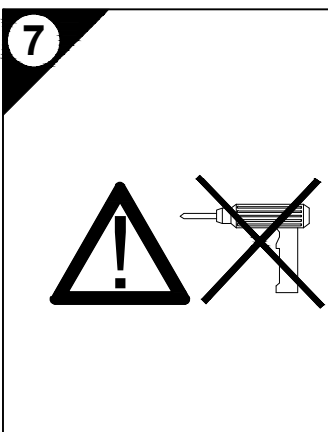

**OPTI  
FIT**

JAKA-BKL GmbH  
Jaka Straße 3  
D-32351 Stenwede-Wehdem

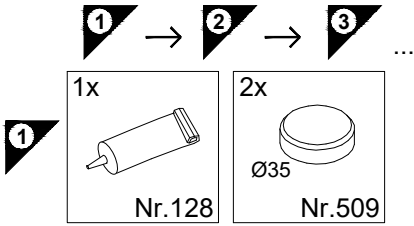
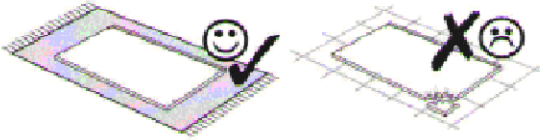
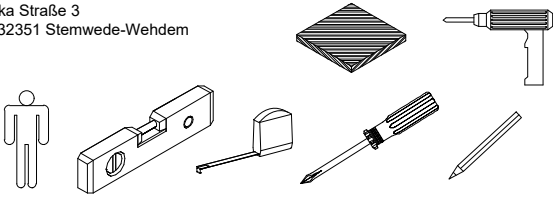

**Service-Hotline**  
**01805-678101**  
0,14€ pro Min.  
**++49 für Österreich**  
Auslandstarif pro Min.  
**service@jaka-bkl.de**  
voor Nederland en België  
**00800-40119350**  
**benelux@jaka-bkl.de**

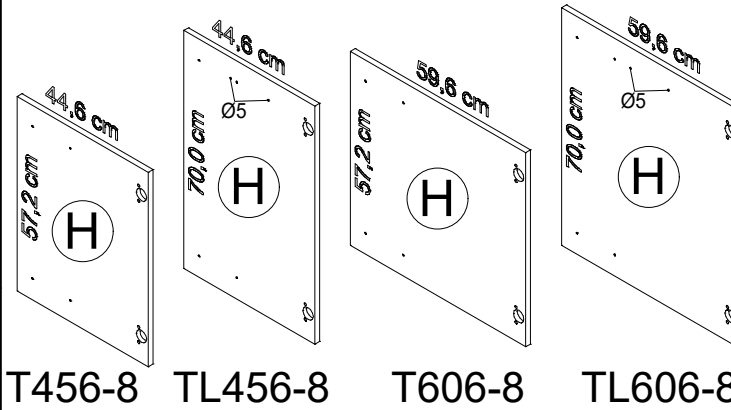

# Montageanleitung

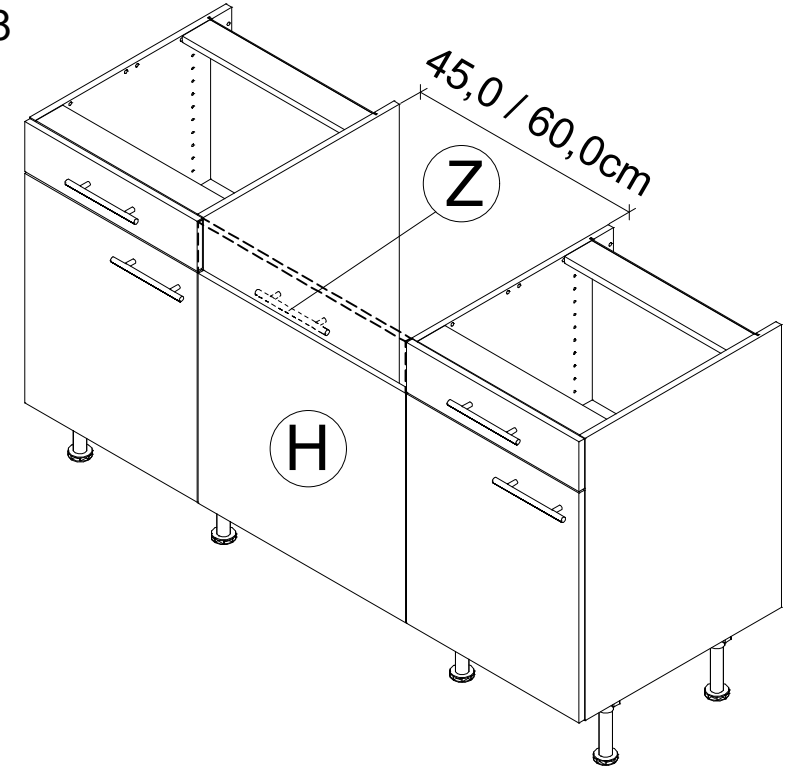
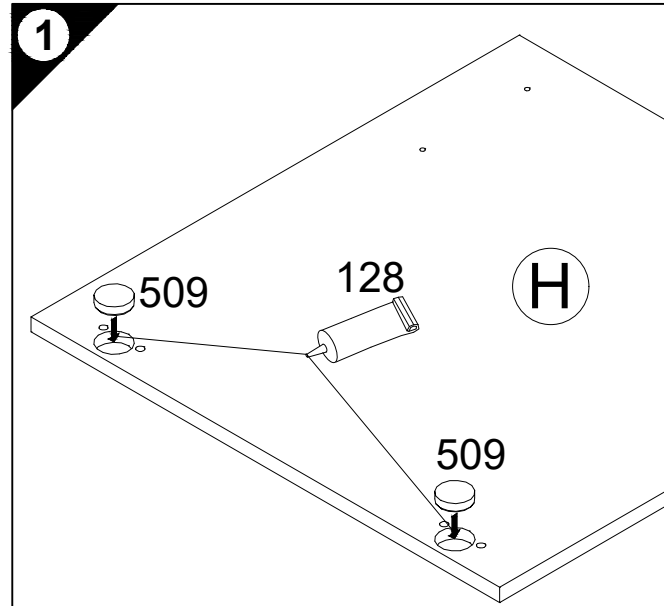
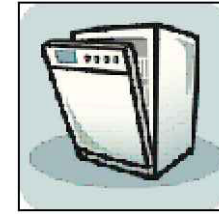

Ersatzteile/Spare parts/pièces de rechange/Reserveonderdelen/Piezas de recambio/Ricambi/Запасные части/Części zamienne/  
pótkatrészek/Náhradní části/Nadomestni deli/varaosat/reservdelar/náhradné diely/Utilizați piese de schimb/Yedek parçalar

T 456-8 | |H| E940616  
TL 456-8 | |H| E940620 |Z| E447100

T 606-8 | |H| E940611  
TL 606-8 | |H| E940621 |Z| E447100

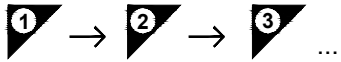

2

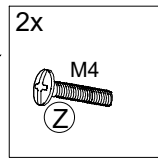

TL456-8  
TL606-8

2

TL456-8  
TL606-8

- D Holzunterlage verwenden!  
Front andrücken, scharfen Bohrer verwenden  
und mit wenig Druck durchbohren!
- GB Use a wooden base!  
Press front down, use sharp drill bit  
and, by applying slight pressure, drill a hole
- F Utiliser un support en bois !  
Appuyer sur la façade, utiliser un foret bien affûté  
et percer en appliquant une faible pression !
- NL Houten onderlegger gebruiken!  
Druk het front aan, gebruik een scherpe boor  
en oefen bij het boren weinig druk uit!
- E ¡Utilizar una base de madera!  
¡Presionar el frente, utilizar una broca afilada  
y taladrar con poca presión!
- I Utilizzare una base di legno! Appoggiare la facciata,  
utilizzare una punta di trapano affilata  
e trapanare esercitando solo una leggera pressione!
- RUS Использовать деревянную подложку!  
Прижать фасад, использовать острое сверло  
и просверлить с незначительным давлением!
- PL Używać podkładkę z drewna!  
Docisnąć front, użyć ostrego wiertła  
i przewiercić, używając małej siły nacisku!
- H Alkalmazzon fa alátétet!  
Nyomja le az előlapot, használjon éles fúrót,  
és kis nyomással fúrja át!
- CZ Použijte dřevěný podklad!  
Přitlačte čelo, použijte ostrý vrták  
a provrtejte pomocí malého tlaku!
- SLO Uporabite leseno podlago!  
Pritisnite ličnico ter z ostrim svedrom  
in z majhnim pritiskom izvrtajte luknjo!
- FIN Käytä puualustaa!  
Paina etulevy paikoilleen, käytä terävää  
poranterää ja poraa reikä vain kevyesti painamalla!
- S Använd ett träunderlag!  
Tryck fronten mot underlaget, använd vass borrh  
och borra igenom med ett lätt tryck!
- SK Použite drevený podklad!!  
Přitlačte front, použite ostrý vrták a prevrtajte miernym tlakom!
- RO suport de lemn! Împingeți frontul, utilizați un burghiu  
ascuțit și perforați exercitând doar o presiune redusă!
- TR Ahşap taban kullanın!  
Önden bastrın, keskin matkap ucu kullanın ve az basınç  
uygulayarak delin!

b)

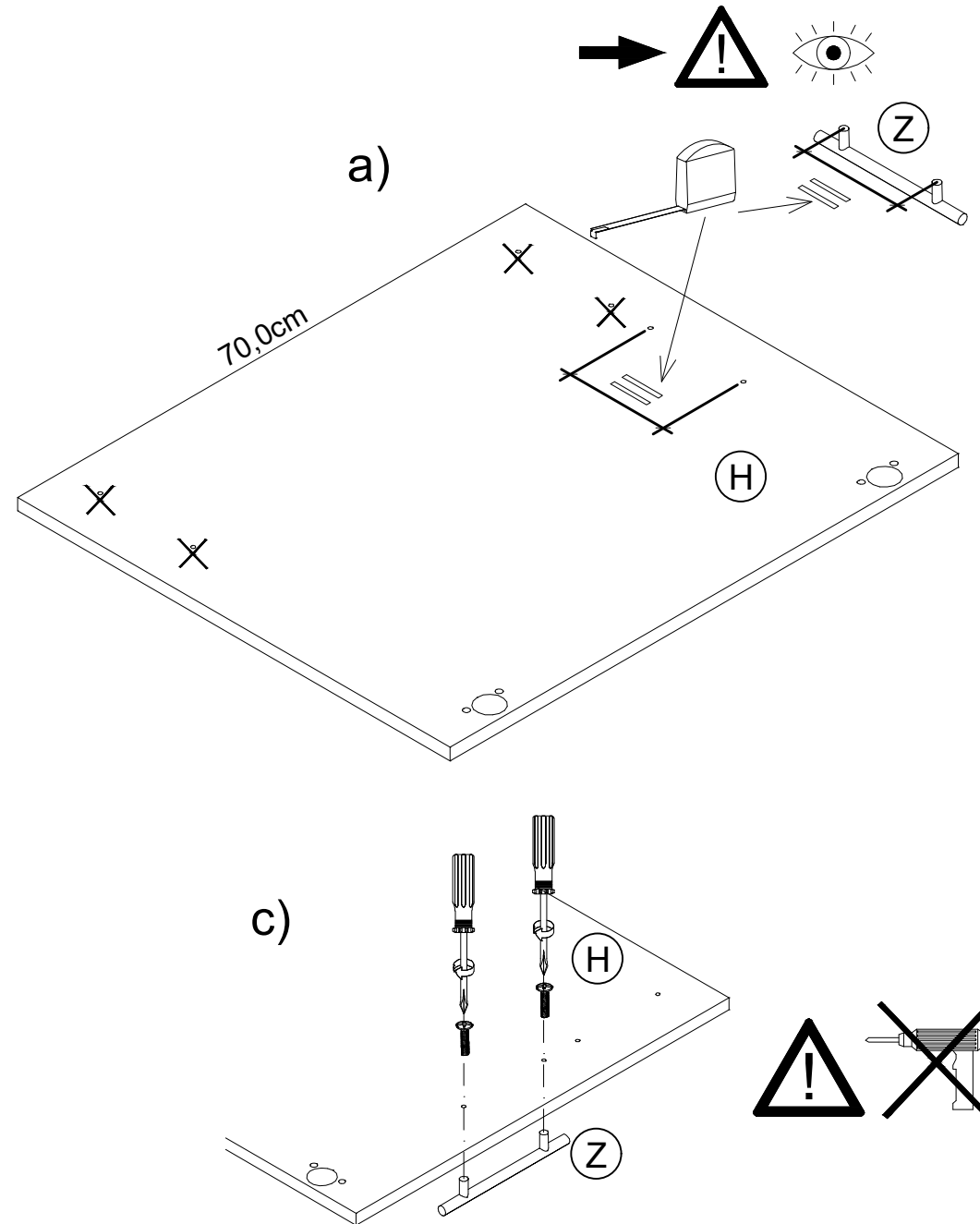
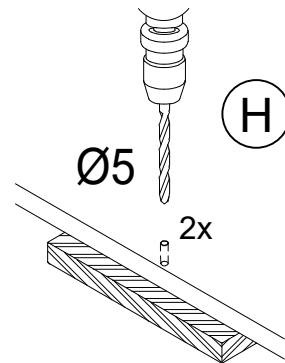

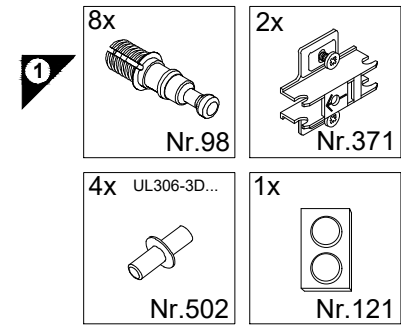
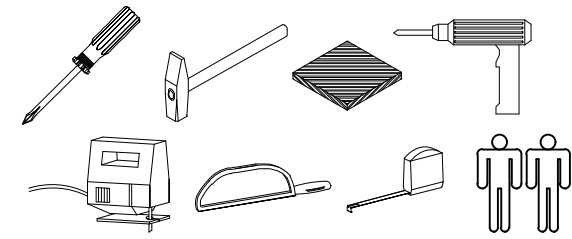

**Service-Hotline**  
**01805-678101**  
0,14€ pro Minute  
**++49 für Österreich**  
Auslandstarif pro Minute  
**service@jaka-bkl.de**  
voor Nederland en België  
**00800-40119350**  
**benelux@jaka-bkl.de**

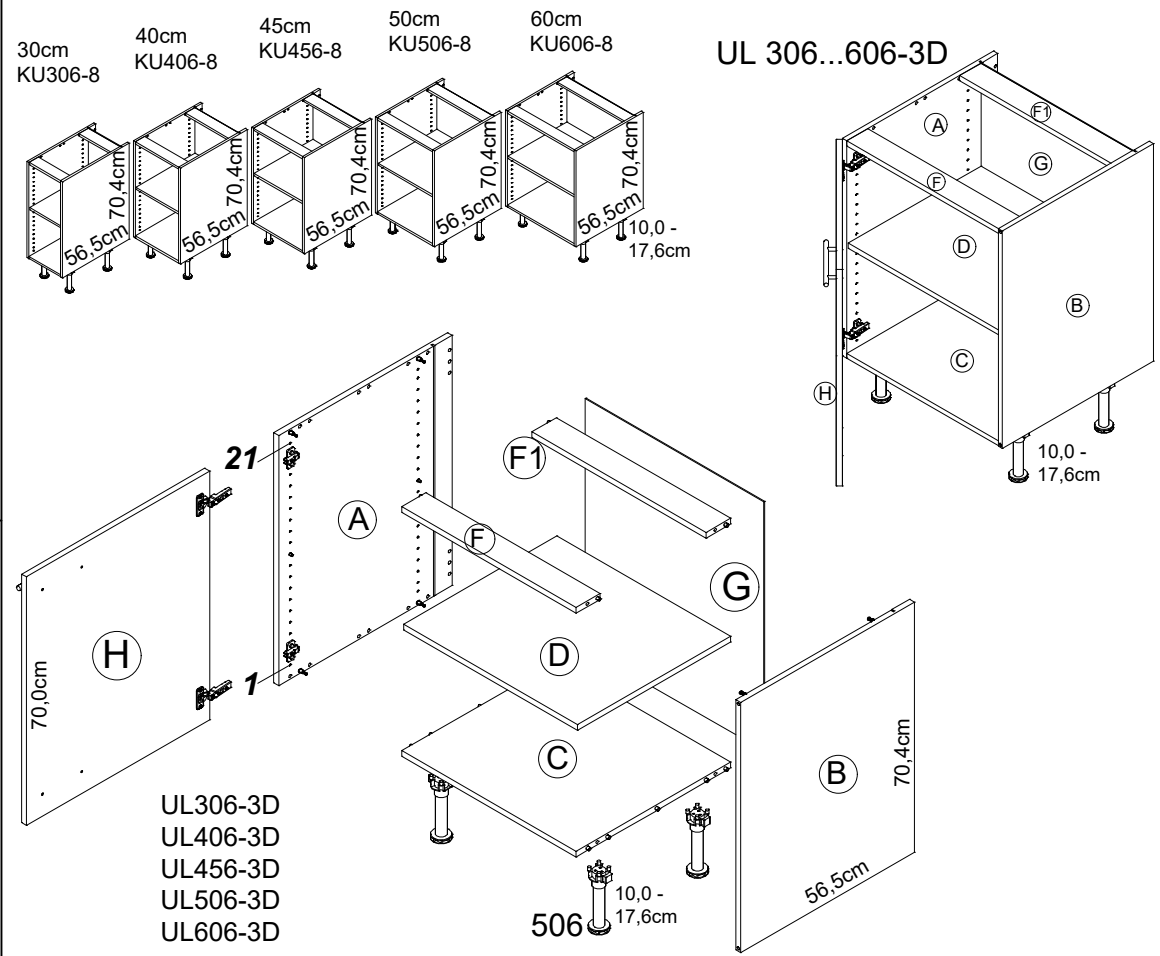

# Montageanleitung

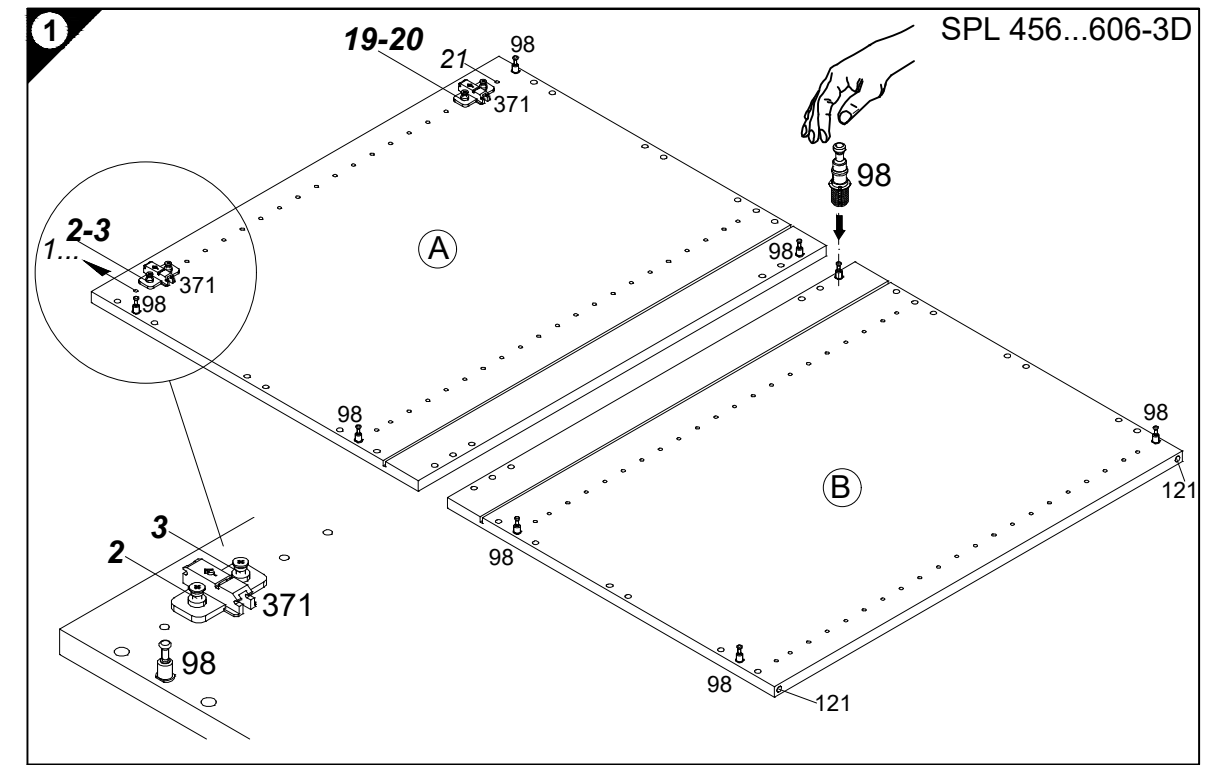
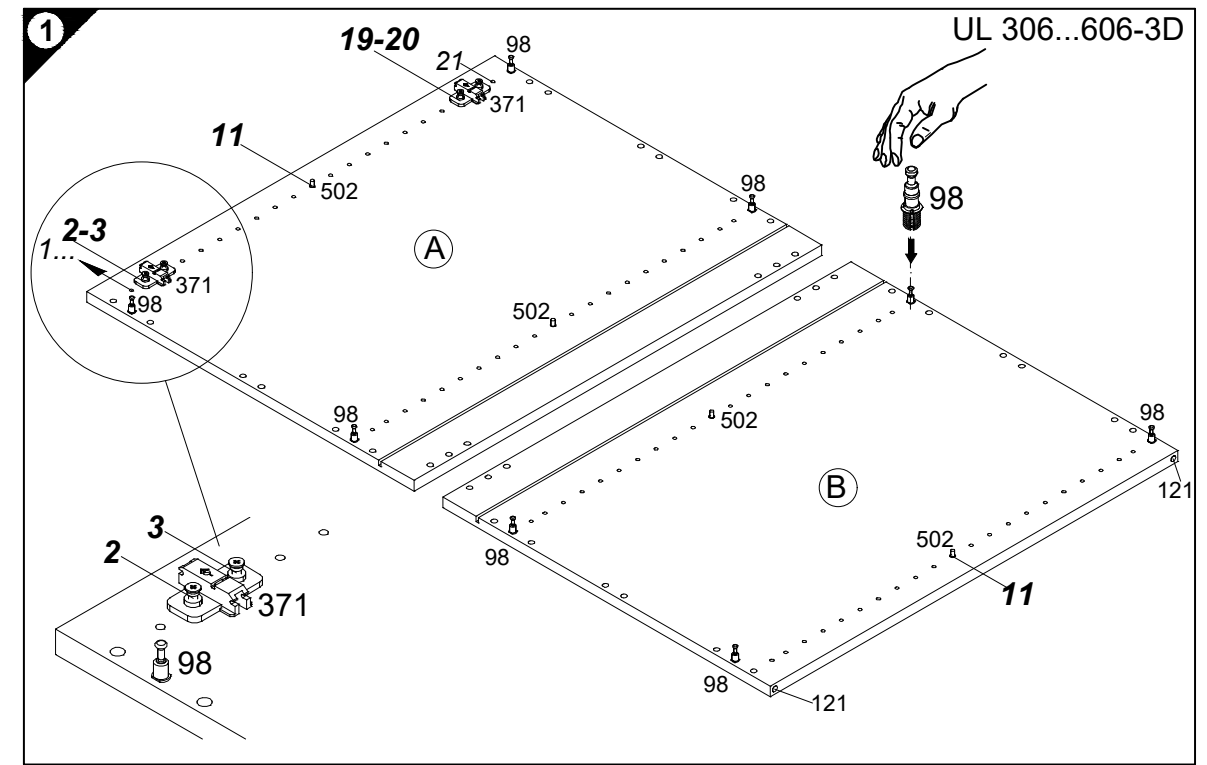
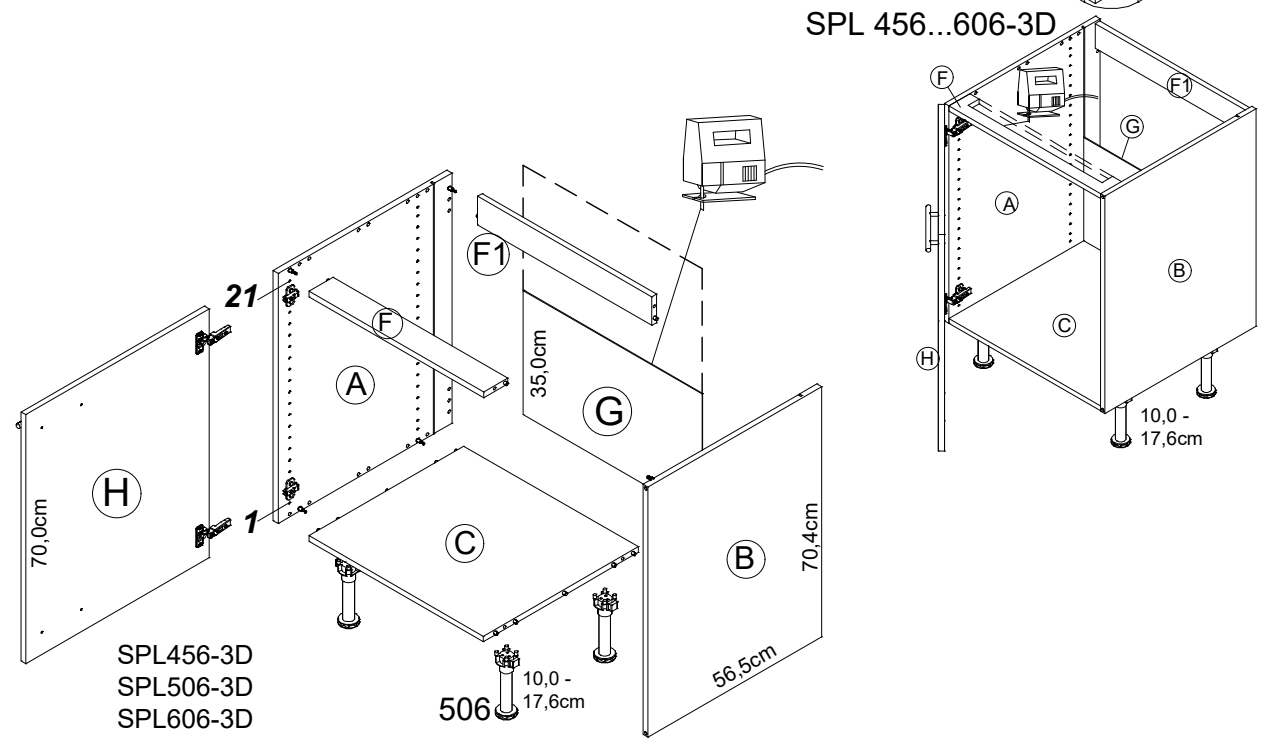

Ersatzteile/Spare parts/pièces de rechange/Reserveonderdelen/Piezas de recambio/Ricambi/Запасные части/Części zamienne/pótalkatrészek/Náhradní části/Nadomestni deli/varaosat/reservdelar/náhradné diely/Utilizați piese de schimb/Yedek parçalar

30cm UL 306-3D	(A) E941021	(B) E941021	(C) E951216	(D) E950306	(F) E942976	(F1) E952976	(G) E970006	(H) E940624
40cm UL 406-3D	(A) E941021	(B) E941021	(C) E951215	(D) E950305	(F) E942975	(F1) E952975	(G) E970010	(H) E940623
45cm UL 456-3D	(A) E941021	(B) E941021	(C) E951227	(D) E950308	(F) E942977	(F1) E952977	(G) E970070	(H) E940620
50cm UL 506-3D	(A) E941021	(B) E941021	(C) E951224	(D) E950304	(F) E942974	(F1) E952974	(G) E970117	(H) E940622
60cm UL 606-3D	(A) E941021	(B) E941021	(C) E951223	(D) E950303	(F) E942973	(F1) E952973	(G) E970116	(H) E940621
45cm SPL 456-3D	(A) E941021	(B) E941021	(C) E951227	(F) E942977	(F1) E952977	(G) E970070	(H) E940620	
50cm SPL 506-3D	(A) E941021	(B) E941021	(C) E951224	(F) E942974	(F1) E952974	(G) E970117	(H) E940622	
60cm SPL 606-3D	(A) E941021	(B) E941021	(C) E951223	(F) E942973	(F1) E952973	(G) E970116	(H) E940621	

1 → 2 → 3 ...

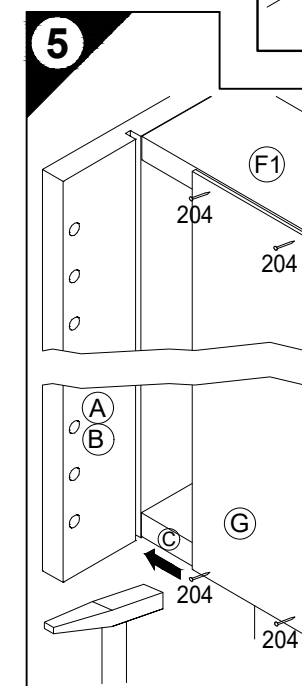
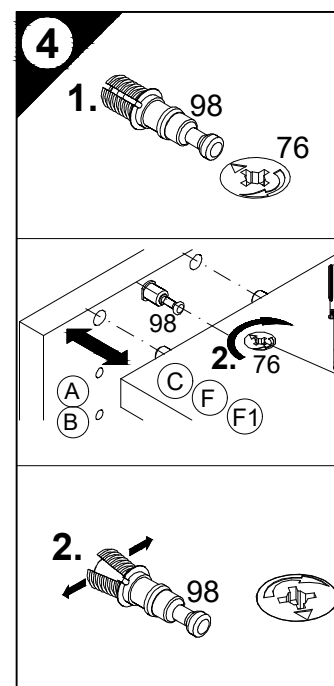
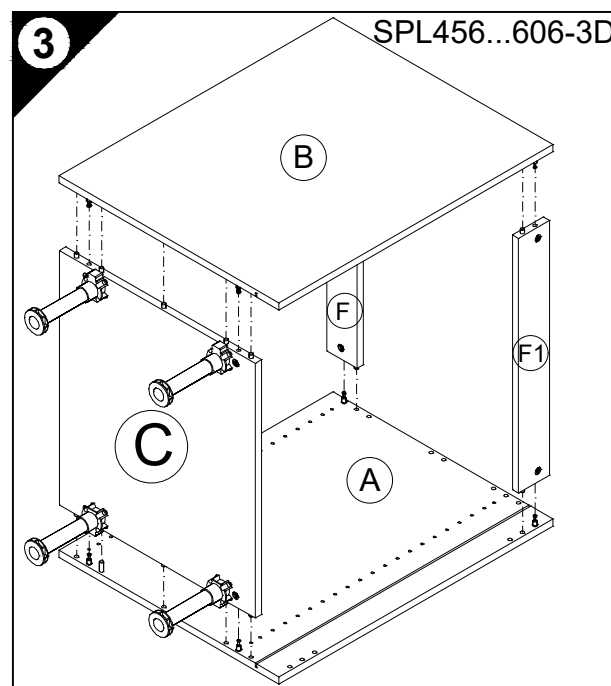
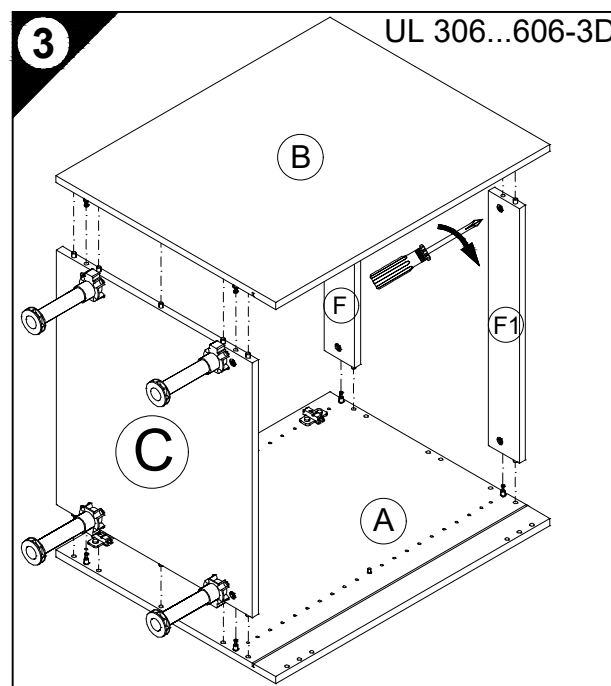
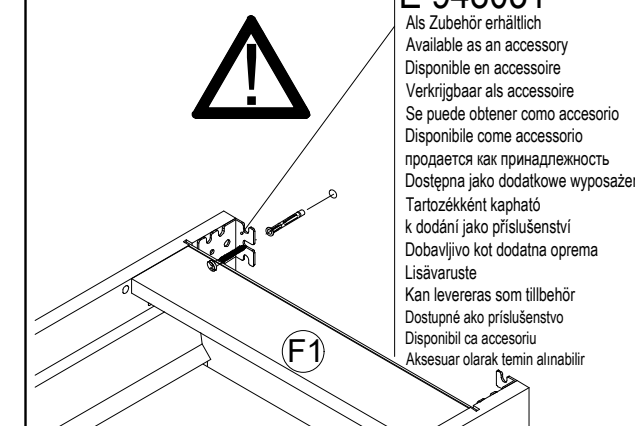
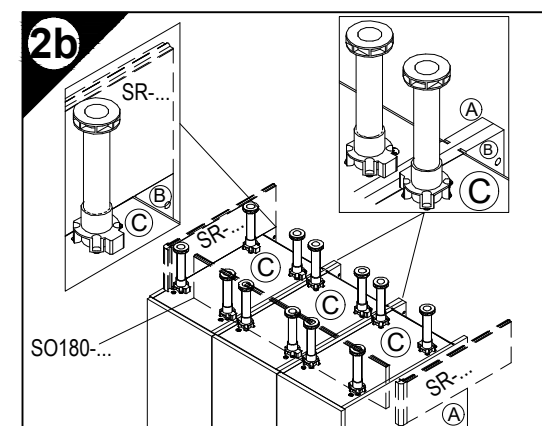
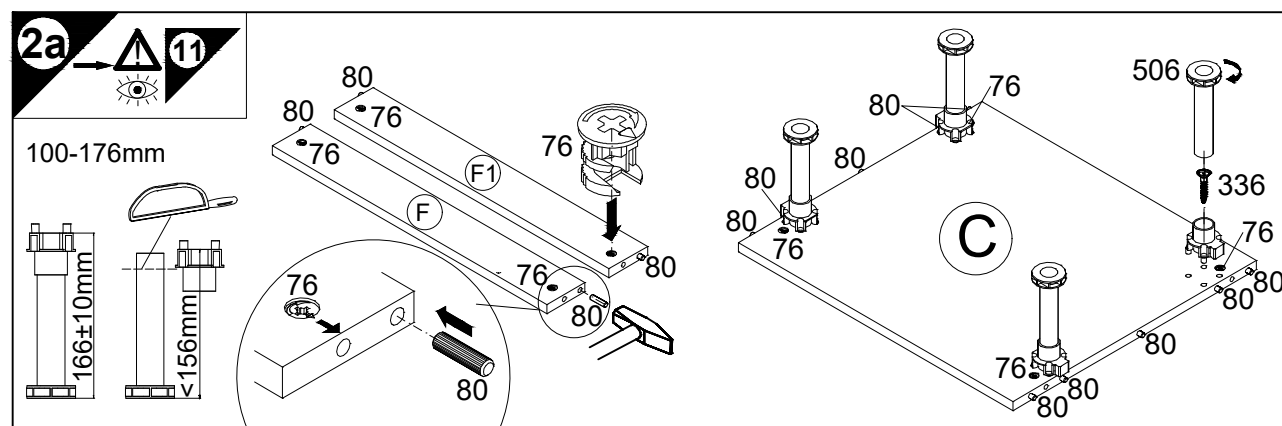
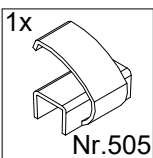
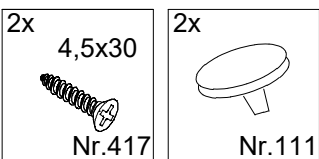
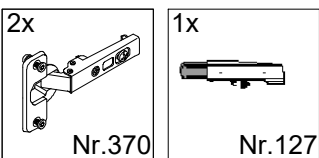
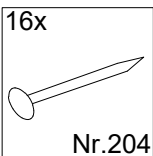
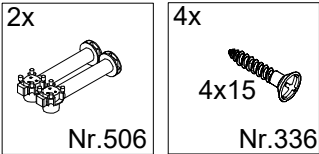
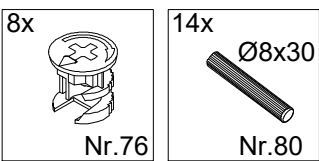

D Die äußeren Schränke von miteinander zu einer Zeile verbundenen beliebigen Anzahl von Unterschränken, sowie einzeln stehende Unterschränke müssen mit Wandbefestigungswinkeln versehen werden.

GB The outer cabinets must be fitted with wall mounting brackets if a row of any number of base units or individual base units are to be connected together.

F Les armoires extérieures de tous meubles bas montés en ligne doivent être munies d'équerres de fixation murale. Il en va de même pour les meubles bas indépendants.

NL De buitenste kasten van met elkaar tot een rij verbonden willekeurig aantal onderkasten, evenals apart staande onderkasten, moeten van wandbevestigingsbeugels worden voorzien.

E Los armarios inferiores de los extremos, de una línea de módulos inferiores cuantos se deseen, deberán ser fijados a la pared con escuadras de fijación mural, así como los armarios inferiores que se monten aislados de forma independiente.

I I mobili esterni al pari dei lavabi sparsi devono essere dotati di staffe di fissaggio a muro, se un numero qualsiasi di sottolavabi viene collegato l'uno con l'altro in una fila.

RUS Если несколько напольных шкафов соединено вместе в единую секцию, то крайние шкафы следует привинтить к стене уголками. Отдельно стоящие напольные шкафы также следует крепить к стене уголками.

PL Jeżeli dolne szafki połączone są ze sobą w szereg, to w uchwyty ścienne należy wyposażyć szafki zewnętrzne. Pojedyncze, wolnostojące dolne szafki, również należy wyposażyć w uchwyty.

H A tetszőleges számú, egymáshoz rögzített alsó szekrényekből álló sor szélső szekrényeit, valamint a különálló alsó szekrényeket fali rögzítő profillal kell ellátni.

CZ Ke stěně je nutno úhelníkem připevnit samostatně stojící skřínky a vnější skřínky, pokud jsou spolu s dalšími skřínky spojeny v jedné řadě.

SLO Zunanje omare se morajo pričvrstiti s pritrilnimi zidnimi kotniki, kadar se povezujejo v eno linijo s poljubnim številom spodnjih omaric. Prav tako, se morajo prostostoječe spodnje omare, pričvrstiti s pritrilnimi zidnimi kotniki.

FIN Aikaapeista muodostuvan kaappirivin uloimmat kaapit on varustettava seinäankinnityskulmilla, samoin kuin yksittäiskaapitkin.

S De yttre skåpen måste förseas med väggfästevinkel när ett valfritt antal underskåp förbinds till en rad. Även separat stående underskåp måste förseas med väggfästevinkel.

SK Na vonkajšie skrinky ľubovoľného počtu spodných skriniek spojených do jedného radu, ako aj na samostatne stojace spodné skrinky je potrebné namontovať nástenný uholník.

RO Părțile exterioare ale dulapurilor inferioare, indiferent de numărul lor, care sunt legate între ele într-un șir, precum și dulapurile inferioare individuale trebuie prevăzute cu corniere pentru fixarea de perete.

TR Bir hat halinde birbirine bağlanmış olan çeşitli sayıdaki alt dolapların dış bölümlünde kalan dolaplar, tek başına duran alt dolaplar, duvar sabitleme köşebentleri ile duvara bağlanmalıdır.

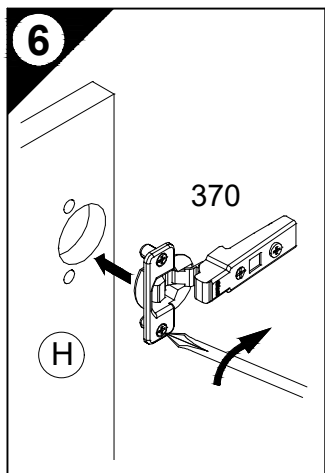

7

D Holzunterlage verwenden!  
Front andrücken, scharfen Bohrer verwenden und mit wenig Druck durchbohren!  
Use a wooden base!  
Press front down, use sharp drill bit and, by applying slight pressure, drill a hole  
Utiliser un support en bois!  
Appuyer sur la façade, utiliser un foret bien affûté et percer en appliquant une faible pression!

F Houten onderlegger gebruiken!  
Druk het front aan, gebruik een scherpe boor en oefen bij het boren weinig druk uit!  
¡Utilizar una base de madera!  
¡Presionar el frente, utilizar una broca afilada y taladrar con poca presión!  
Utilizzare una base di legno!  
Appoggiare la facciata, utilizzare una punta di trapano affilata e trapanare esercitando solo una leggera pressione!

NL Houten onderlegger gebruiken!  
Druk het front aan, gebruik een scherpe boor en oefen bij het boren weinig druk uit!  
¡Utilizar una base de madera!  
¡Presionar el frente, utilizar una broca afilada y taladrar con poca presión!  
Utilizzare una base di legno!  
Appoggiare la facciata, utilizzare una punta di trapano affilata e trapanare esercitando solo una leggera pressione!

RUS Использовать деревянную подложку!  
Прижать фронт, использовать острое сверло и просверлить с незначительным давлением!  
Używać podkładkę z drewna!  
Docisnąć front, użyć ostrego wiertła i przewiercić, używając małej siły nacisku!

H Alkalmazzon fa alátétet!  
Nyomja le az előlapot, használjon éles fűrőt, és kis nyomással fúrja át!

CZ Použijte dřevný podklad!  
Přitlačte čelo, použijte ostrý vrták a provrtejte pomocí malého tlaku!

SLO Uporabite leseno podlago!  
Pritisnite ličnico ter z ostrim svedom in z majhnim pritiskom izvrtajte luknjo!

FIN Käytä puualustaa!  
Paina etulevy paikoilleen, käytä terävää poranterää ja poraa reikä vain kevyesti painamalla!

S Använd ett träunderlag!  
Tryck fronten mot underlaget, använd vass borr och borra igenom med ett lätt tryck!

SK Použite drevený podklad!  
Pritlačte front, použite ostrý vrták a prevrtajte miernym tlakom!

RO Împingeți frontul, utilizați un burghiu ascuțit și perforați exercitând doar o presiune redusă!

TR Ahşap taban kullanın!  
Önden bastırın, keskin matkap ucu kullanın ve az basınç uygulayarak delin!

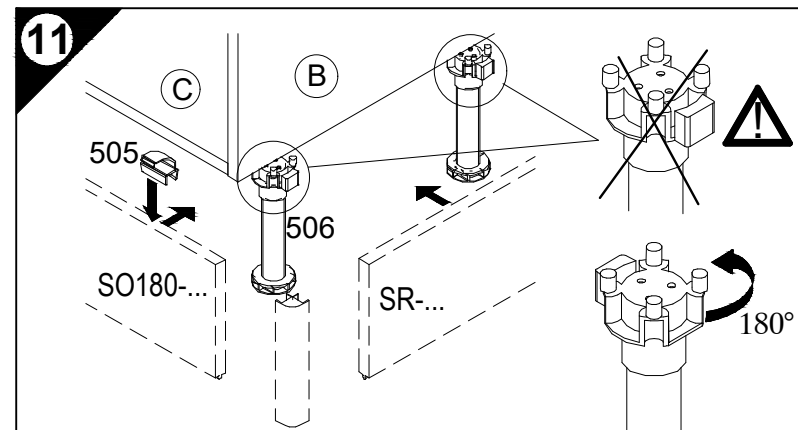
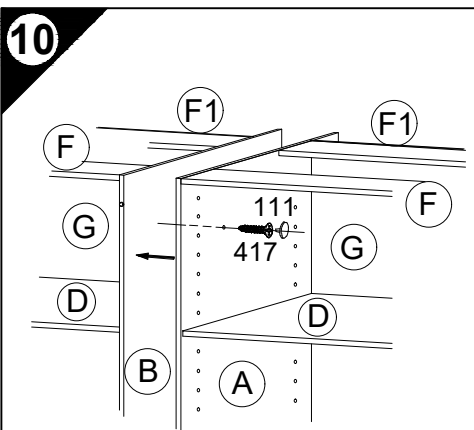
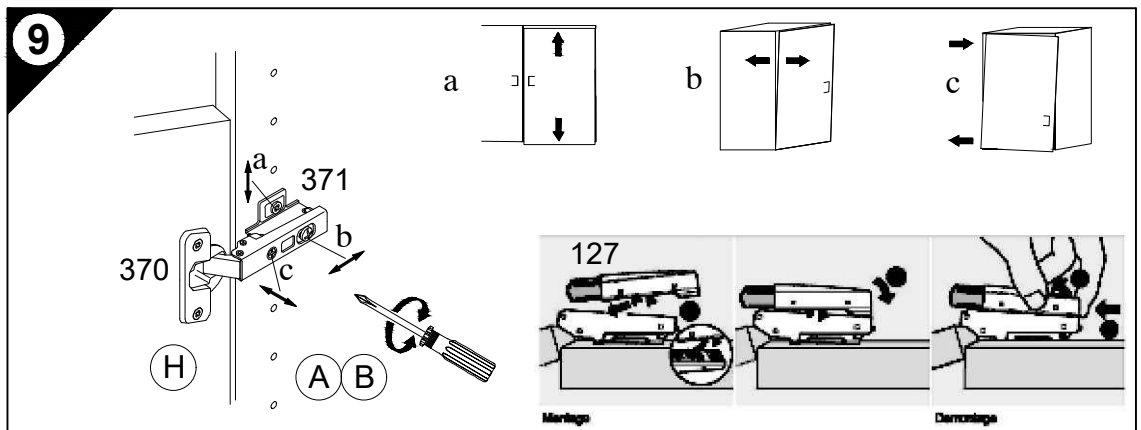
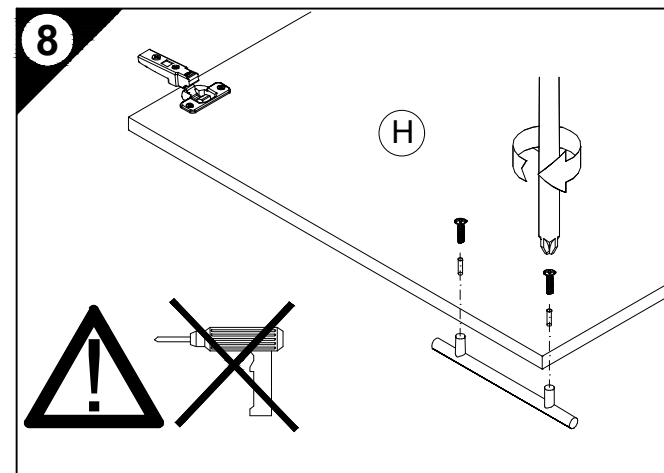
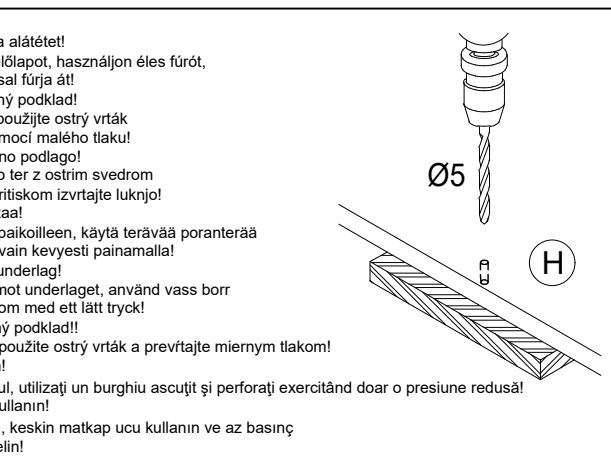



JAKA-BKL GmbH  
Jaka Straße 3  
D-32351 Sternwede-Wehden

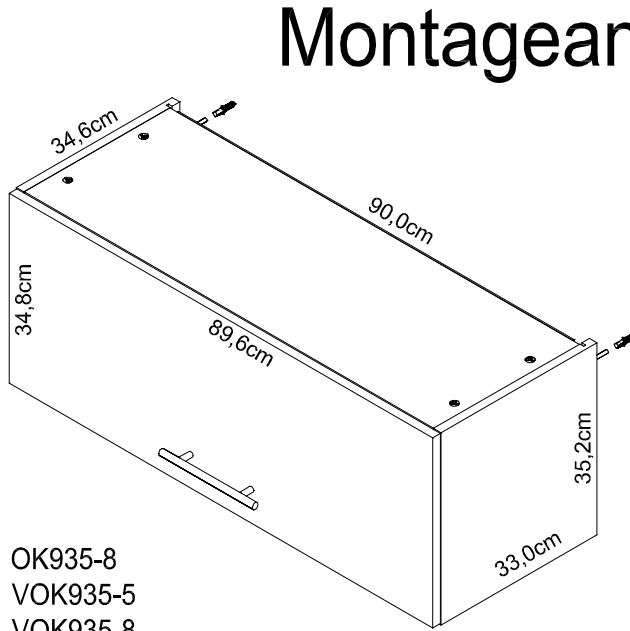
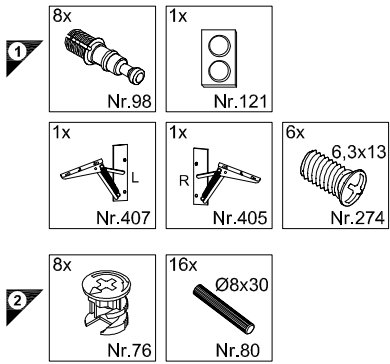
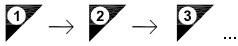
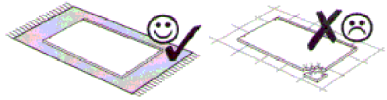
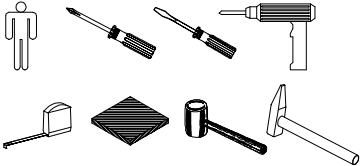

OK935-8  
VOK935-5  
VOK935-8

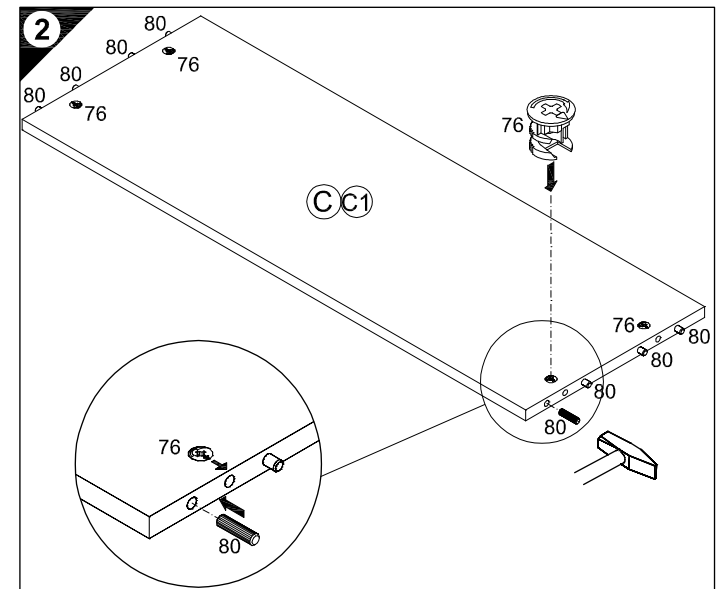
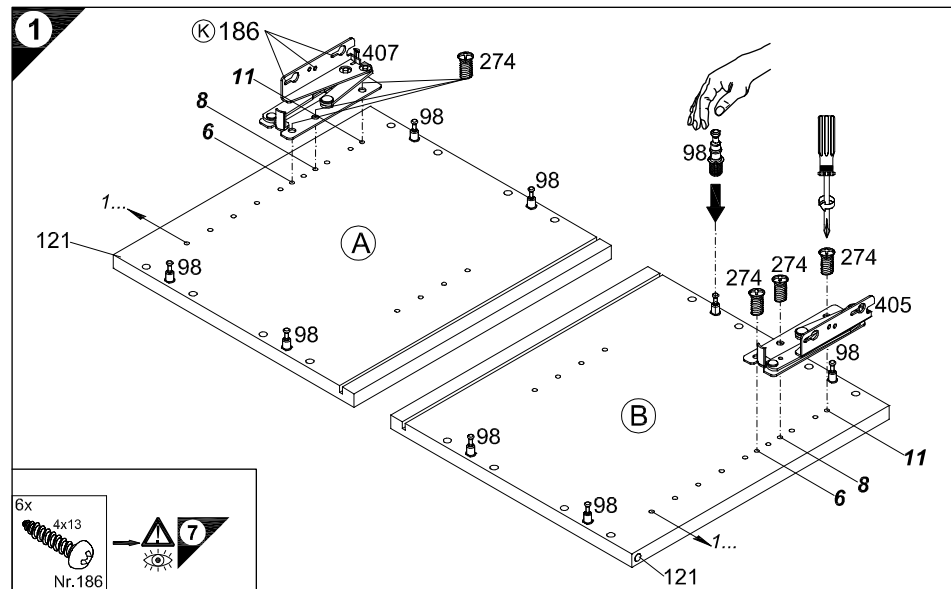
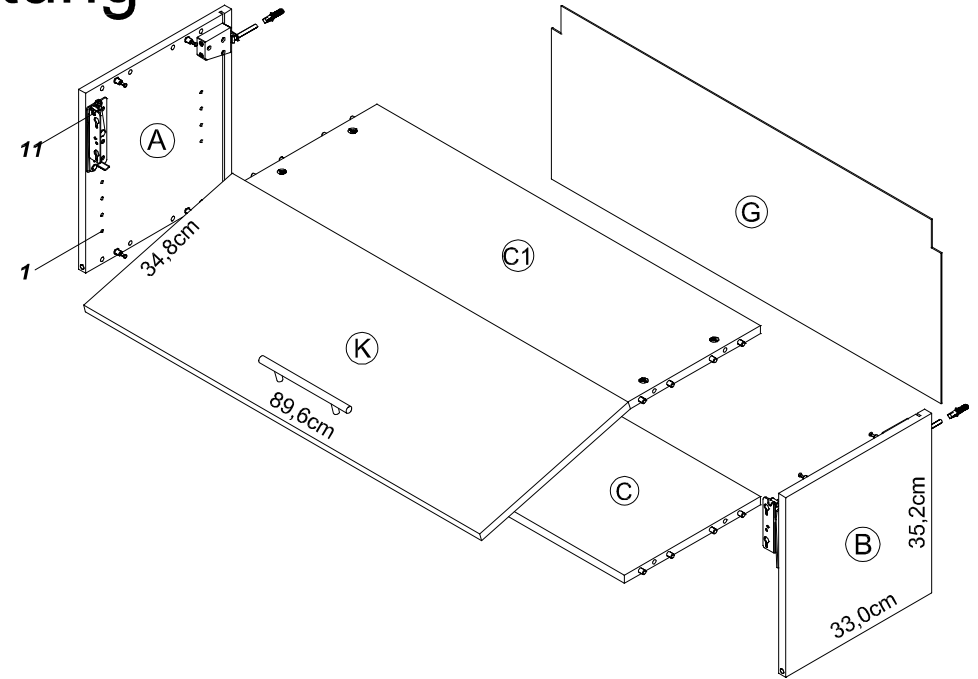

**Service-Hotline**  
01805-678101  
0,14€ pro Minute  
**++49 für Österreich**  
Auslandstarif pro Minute  
**service@jaka-bkl.de**  
voor Nederland en België  
00800-40119350  
**benelux@jaka-bkl.de**

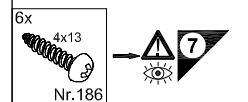

Ersatzteile/Spare parts/pièces de rechange/Reserveonderdelen/Piezas de recambio/Ricambi/Запасные части/Części zamienne/pótalkatrészek/Náhradní části/Nadomestni deli/varaosat/reservdelar/náhradné diely/Utilizați piese de schimb/Yedek parçalar

90cm OK935-8... | (A) E940047 (B) E940048 (C) E941238 (C1) E941238 (G) E970040 (K) E940742



1 → 2 → 3 ...

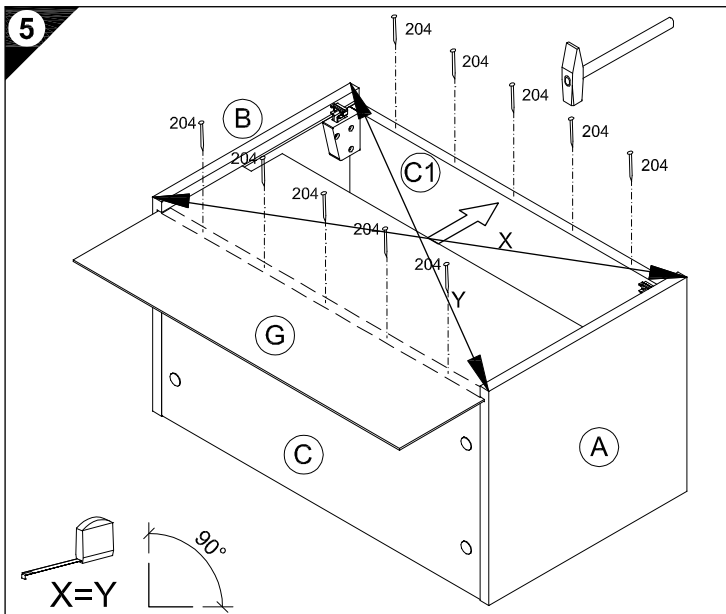
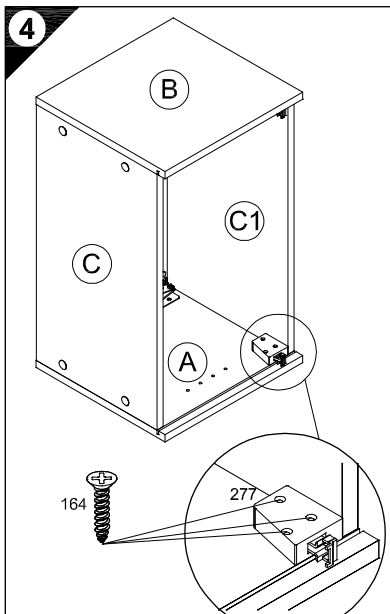
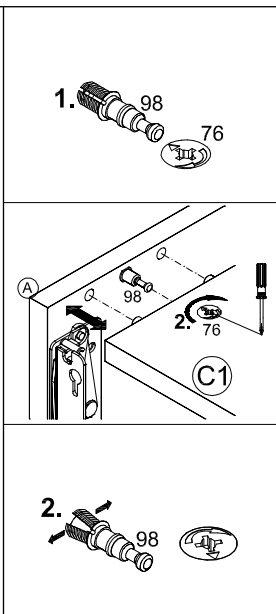
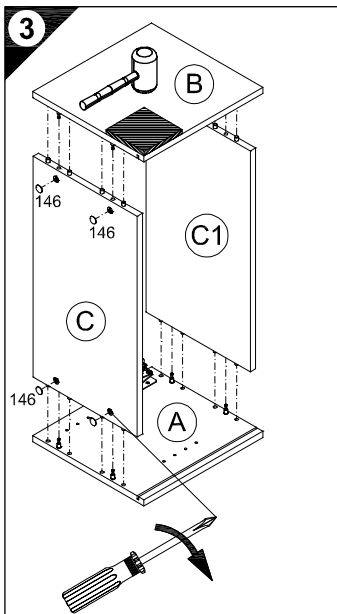
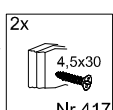
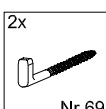
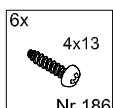
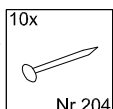
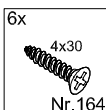
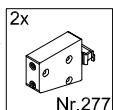
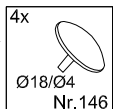

**6** D Holzunterlage verwenden!  
Front andrücken, scharfen Bohrer verwenden und mit wenig Druck durchbohren!  
GB Use a wooden base!  
Press front down, use sharp drill bit and, by applying slight pressure, drill a hole  
F Utiliser un support en bois!  
Appuyer sur la façade, utiliser un foret bien affûté et percer en appliquant une faible pression!  
NL Houten onderlegger gebruiken!  
Druk het front aan, gebruik een scherpe boor en oefen bij het boren weinig druk uit!  
E ¡Utilizar una base de madera!  
¡Presionar el frente, utilizar una broca afilada y taladrar con poca presión!  
I Appoggiare la facciata, utilizzare una punta di trapano affilata e trapanare esercitando solo una leggera pressione!  
RUS Использовать деревянную подложку!  
Прижать фасад, использовать острое сверло и просверлить с незначительным давлением!  
PL Używać podkładkę z drewna!  
Docisnąć front, użyć oстрego wiertła i przewiercić, używając małej siły nacisku!

H Alkalmazzon fa alátétet!  
Nyomja le az előlapot, használjon éles fúrót, és kis nyomással fúrja át!  
CZ Použijte dřevěný podklad!  
Přitlačte čelo, použijte ostrý vrták a provrtajte pomocí malého tlaku!  
SLO Uporabite leseno podlago!  
Pritisnite lönico ter z ostrim svedrom in z majhnim pritiskom izvrtajte luknjo!  
FIN Käytä puualustaa!  
Paina etulevy paikoilleen, käytä terävää poranterää ja poraa reikä vain kevyesti painamalla!  
S Använd ett träunderlag!  
Tryck fronten mot underlaget, använd vass borrh och borra igenom med ett lätt tryck!  
SK Použite drevený podklad!  
Přitlačte front, použijte ostrý vrták a prevrtajte miernym tlakom!  
RO suport de lemn!  
Împingeți frontalul, utilizați un burghiu ascuțit și perforați exercitând doar o presiune redusă!  
TR Ahşap taban kullanın!  
Önden bastırın, keskin matkap ucu kullanın ve az basınç uygulayarak delin!

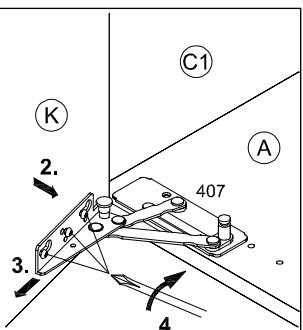
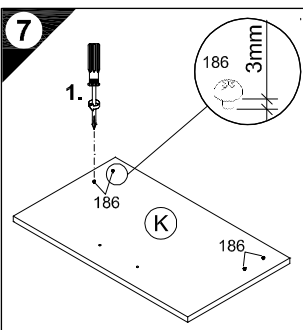
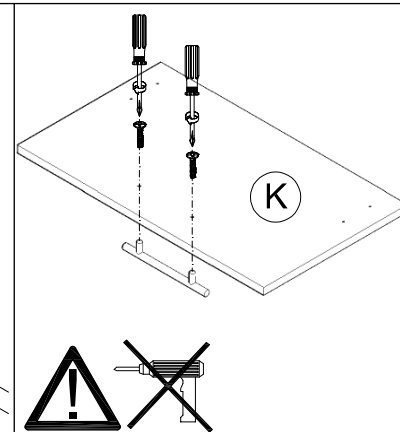
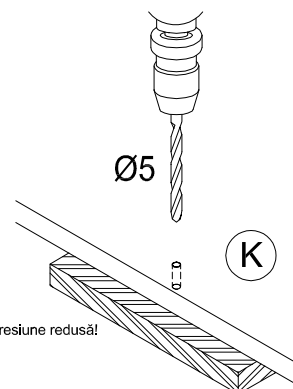

**8** D Untergrund und Befestigungsmittel auf Eignung prüfen!  
GB Check substructure and fixings for suitability!  
F Contrôler si le support et les moyens de fixation sont bien adéquats!  
NL Ondergrond en bevestigingsmateriaal op functionaliteit controleren!  
E ¡Comprobar el suelo y los medios de fijación en cuanto a su aptitud!  
I Controllare l'idoneità del fondo e del materiale di fissaggio!  
RUS Основание и крепежный материал проверить на пригодность!  
PL Podłoże oraz materiały do zamocowania sprawdzić na ich przydatność!  
H Az alapfelületet és a rögzítő anyagokat megfelelőség szempontjából ellenőrizni kell!  
CZ Přezkoušejte podklad a vhodnost upevňovacích prostředků!  
SLO Preverite, če se ujemajo spodnja stran in pritrdilna sredstva!  
FIN Tarkista alustan ja kiinnitysvälineiden sopivuus!  
S Kontrollera att underlaget och fästmedlen är lämpliga!  
SK Preverte vhodnosť podkladu a upevňovacích prostriedkov!  
RO Verificați caracterul adecvat al suprafeței suport și al mijloacelor de fixare!  
TR Zeminin ve bağlanıtı elemanlarının uygunluğunu kontrol edin!

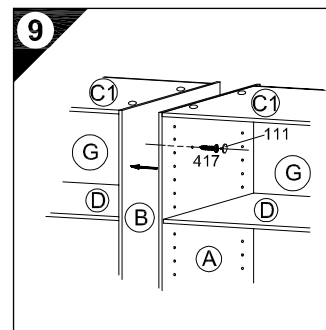
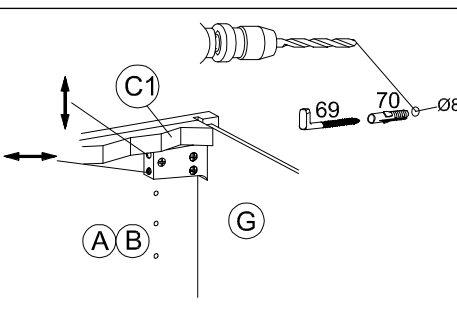



JAKA-BKL GmbH  
Jaka Straße 3  
D-32351 Stemwede-Wehden

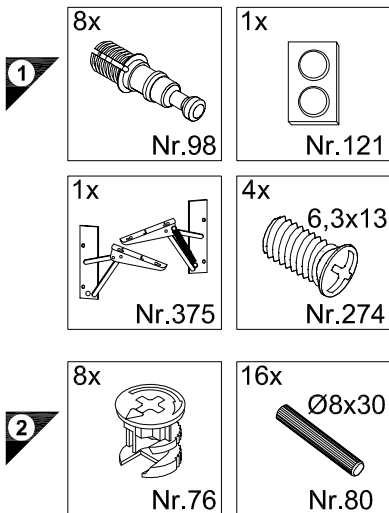
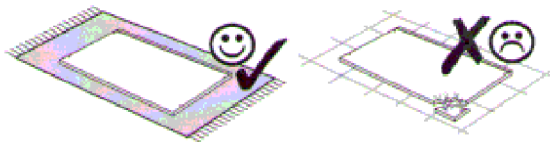
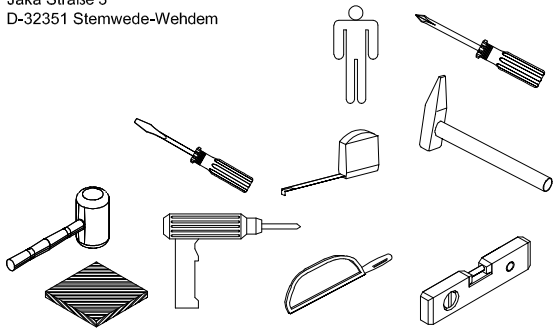

**Service-Hotline**  
01805-678101  
0,14€ pro Minute  
++49 für Österreich  
Auslandstarif pro Minute  
[service@jaka-bkl.de](mailto:service@jaka-bkl.de)  
voor Nederland en België  
00800-40119350  
[benelux@jaka-bkl.de](mailto:benelux@jaka-bkl.de)

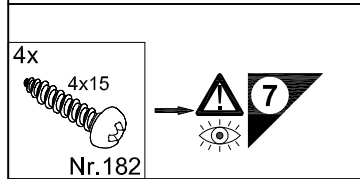
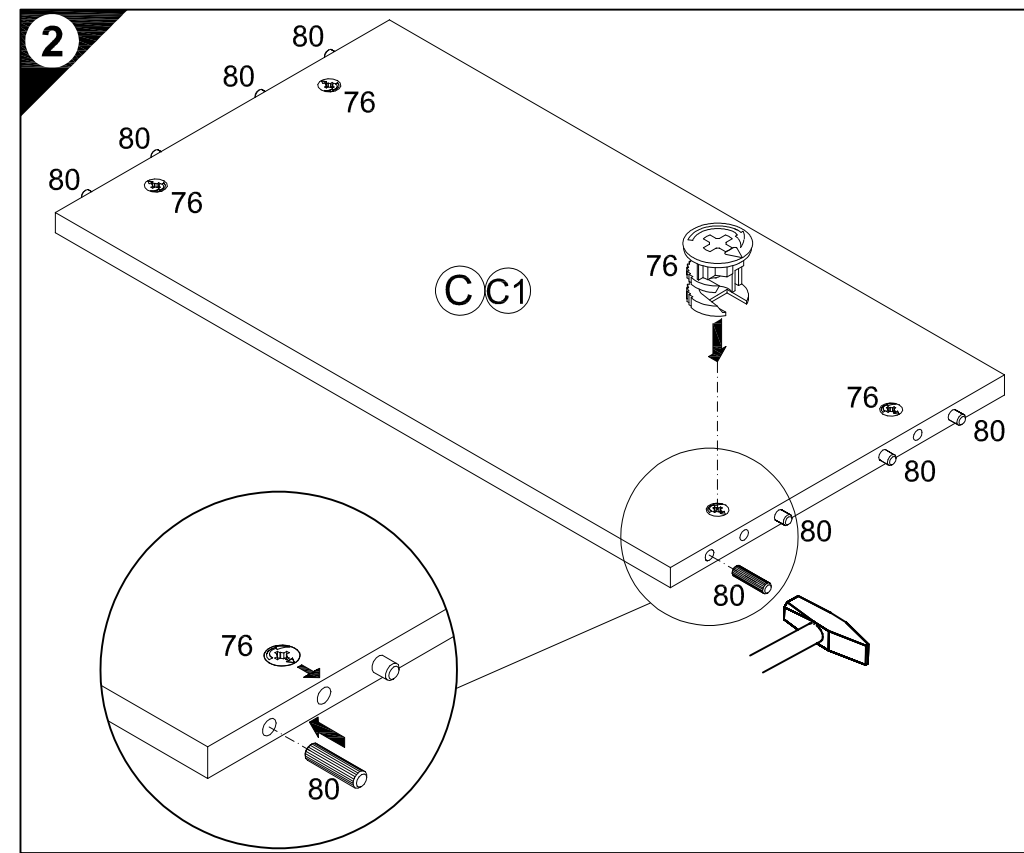
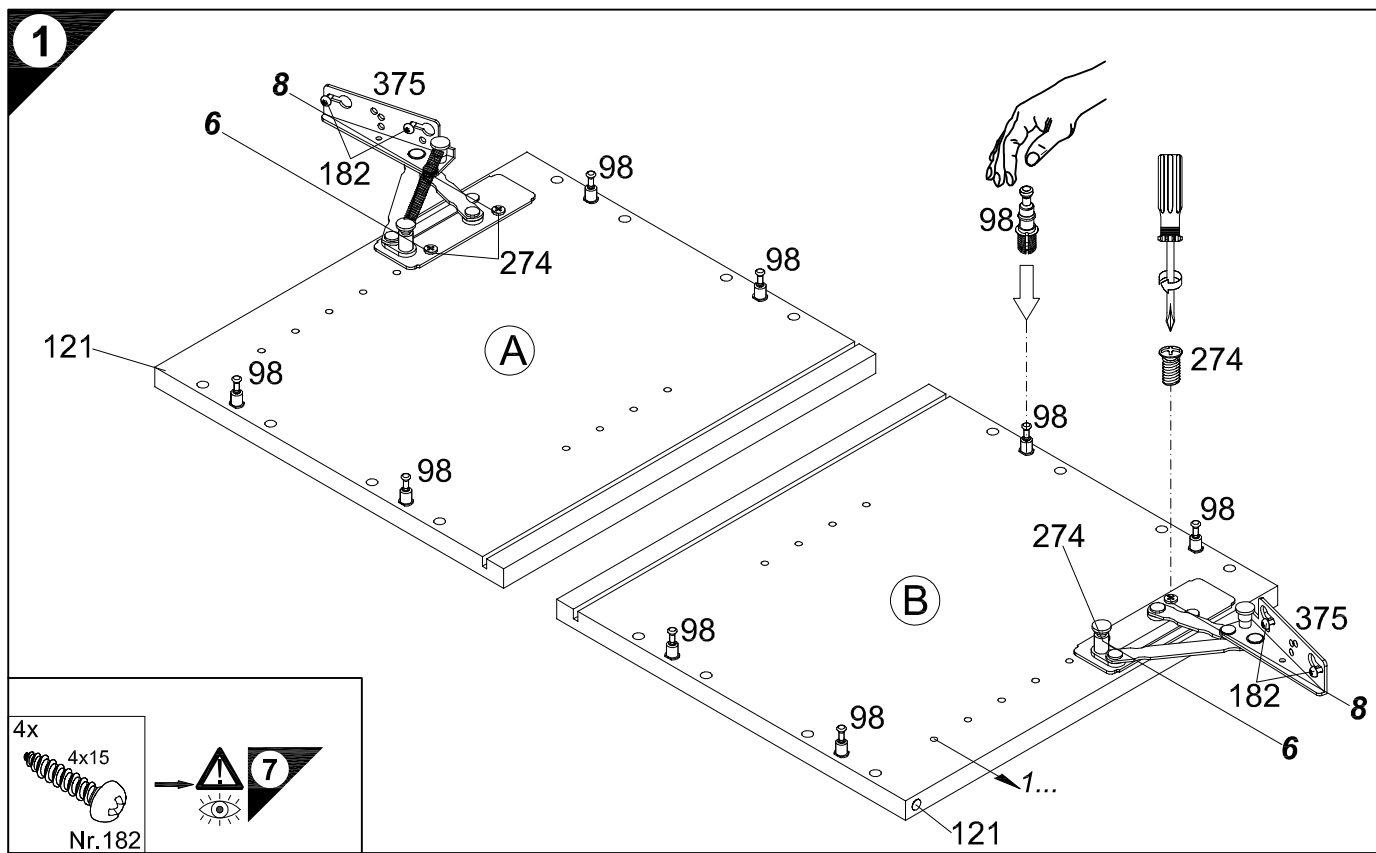
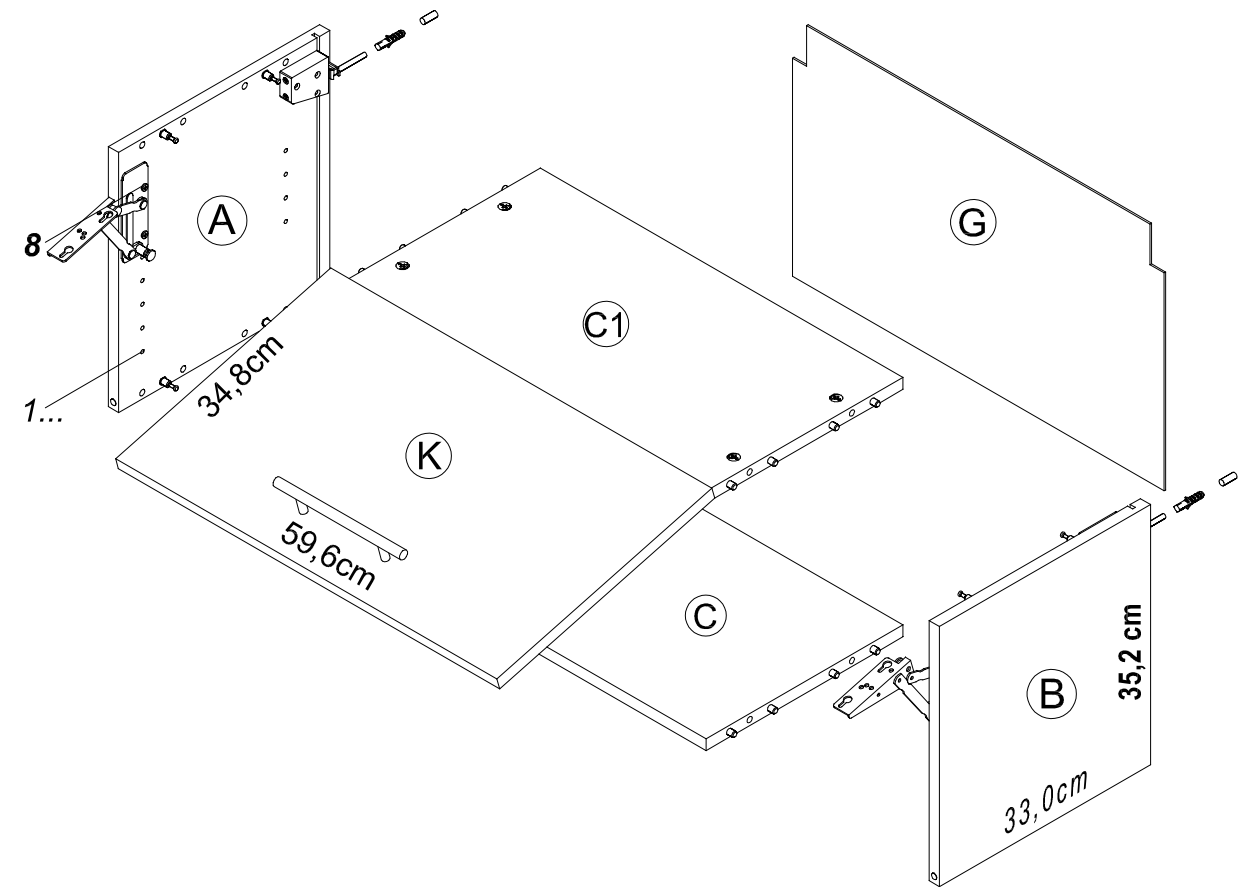
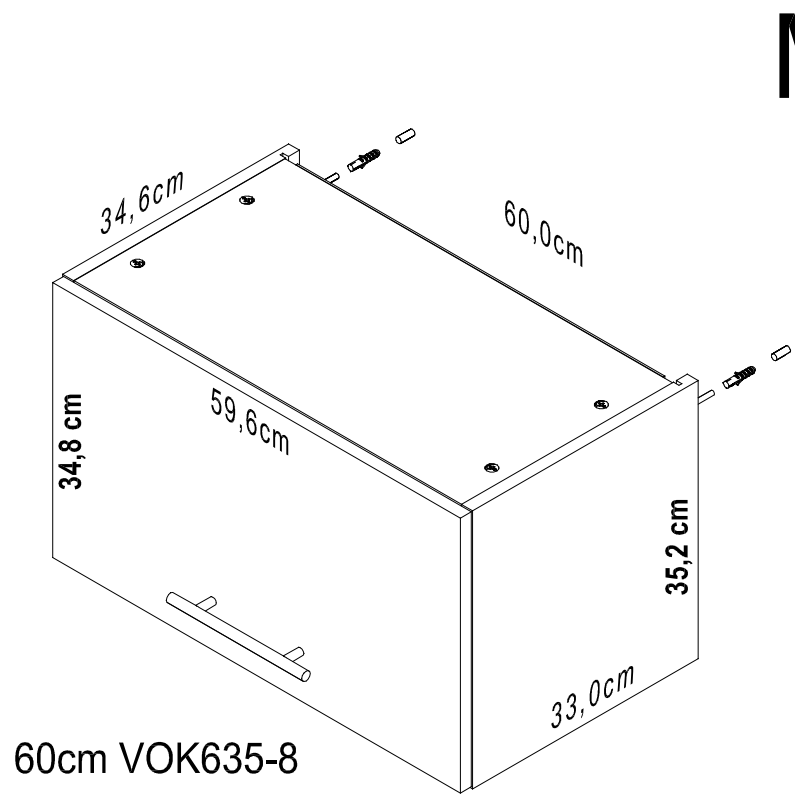

Ersatzteile/Spare parts/pièces de rechange/Reserveonderdelen/Piezas de recambio/Ricambi/Запасные части/Części zamienne/pótalkatrészek/Náhradní části/Nadomestni deli/varaosat/reservdelar/náhradné diely/Utilizați piese de schimb/Yedek parçalar

60cm VOK635-8 | [A] E940034 | [B] E940034 | [C] E941233 | [C1] E941233 | [G] E970038 | [K] E940700

1 → 2 → 3 ...

- 3 4x  
Ø18/Ø4  
Nr.146
- 4 2x  
Nr.277
- 6x  
4x30  
Nr.164
- 5 10x  
Nr.204
- 7 4x  
4x15  
Nr.182
- 8 2x  
Ø8x40  
Nr.70
- 2x  
Nr.69
- 9 2x  
4,5x30  
Nr.417
- 2x  
Nr.111

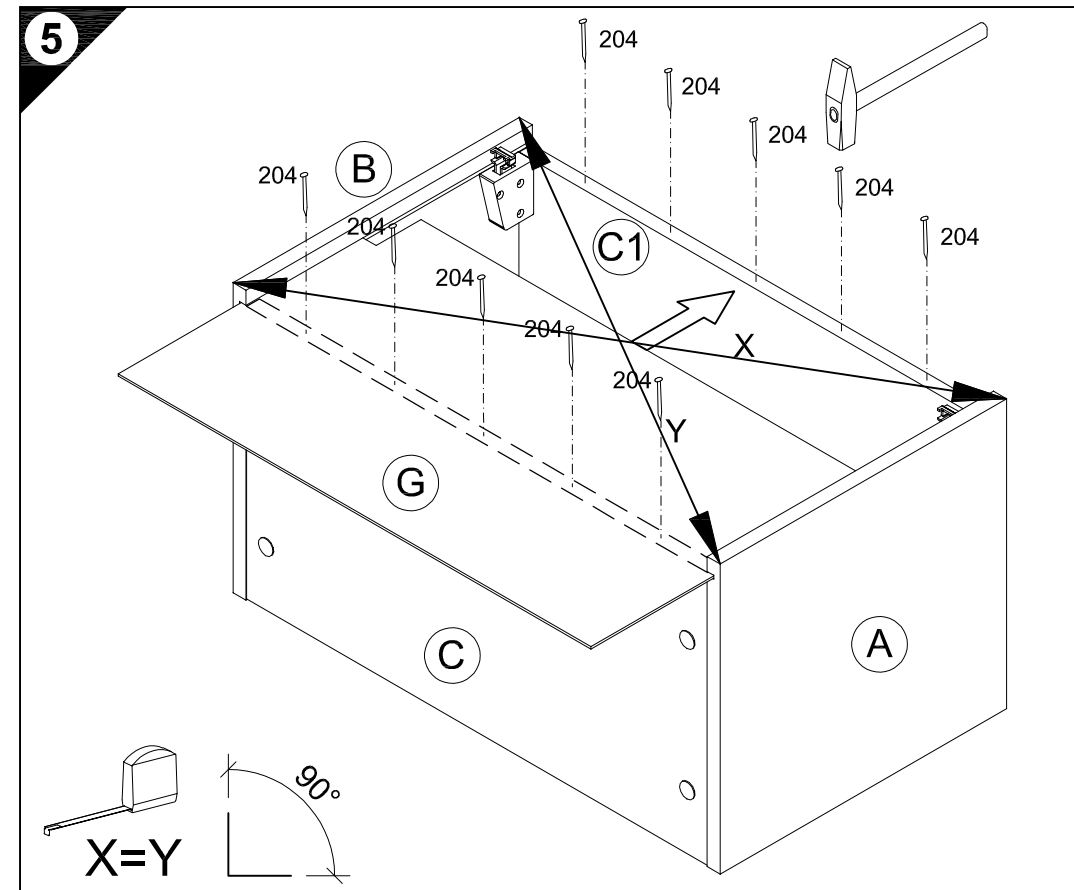
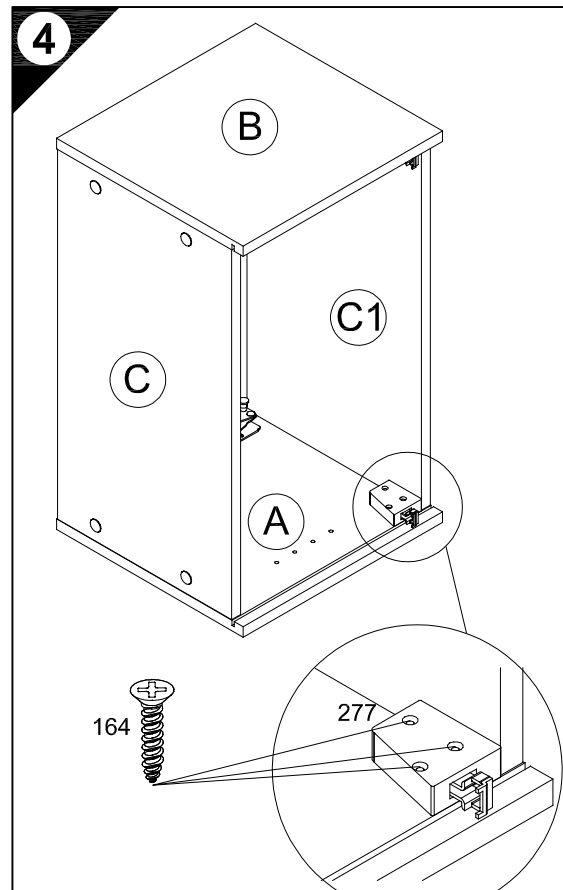
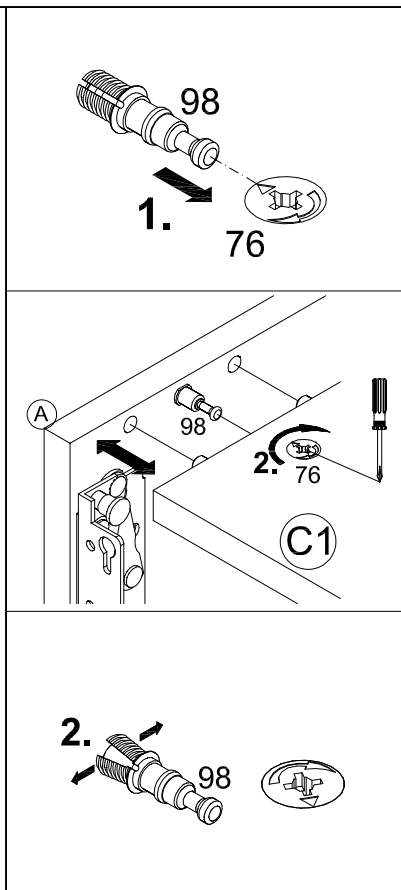
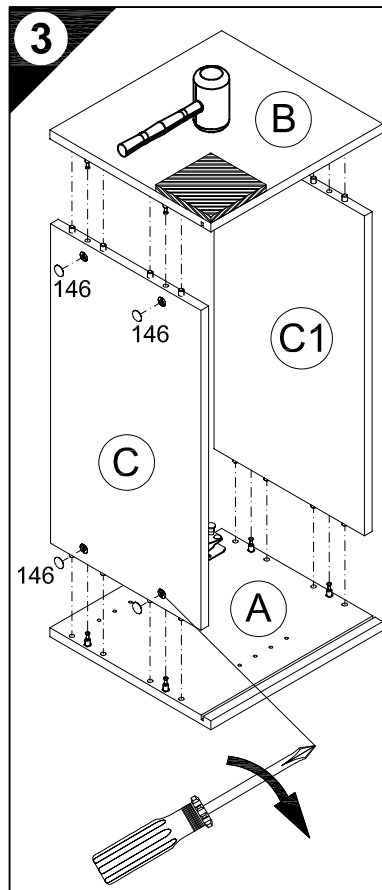

6

- |  |   |
|--|---|
| <p><b>D</b> Holzunterlage verwenden!<br/>Front andrücken, scharfen Bohrer verwenden und mit wenig Druck durchbohren!</p> <p><b>GB</b> Use a wooden base!<br/>Press front down, use sharp drill bit and, by applying slight pressure, drill a hole</p> <p><b>F</b> Utiliser un support en bois !<br/>Appuyer sur la façade, utiliser un foret bien affûté et percer en appliquant une faible pression !</p> <p><b>NL</b> Houten onderlegger gebruiken!<br/>Druk het front aan, gebruik een scherpe boor en oefen bij het boren weinig druk uit!</p> <p><b>E</b> ¡Utilizar una base de madera!<br/>¡Presionar el frente, utilizar una broca afilada y taladrar con poca presión!</p> <p><b>I</b> Utilizzare una base di legno!<br/>Appoggiare la facciata, utilizzare una punta di trapano affilata e trapanare esercitando solo una leggera pressione!</p> <p><b>RUS</b> Использовать деревянную подложку!<br/>Прижать фасад, использовать острое сверло и просверлить с незначительным давлением!</p> <p><b>PL</b> Używać podkładkę z drewna!<br/>Docisnąć front, użyć ostrego wiertła i przewiercić, używając małej siły nacisku!</p> | <p><b>H</b> Alkalmazzon fa alátétet!<br/>Nyomja le az előlapot, használjon éles fúrót, és kis nyomással fúrja át!</p> <p><b>CZ</b> Použijte dřevěný podklad!<br/>Přitlačte čelo, použijte ostrý vrták a provrtějte pomocí malého tlaku!</p> <p><b>SLO</b> Uporabite leseno podlago!<br/>Pritisnite ličnico ter z ostrim svedrom in z majhnim pritiskom izvrtajte luknjo!</p> <p><b>FIN</b> Käytä puualustaa!<br/>Paina etulevy paikoilleen, käytä terävää poranterää ja poraa reikä vain kevyesti painamalla!</p> <p><b>S</b> Använd ett träunderlag!<br/>Tryck fronten mot underlaget, använd vass borrh och borra igenom med ett lätt tryck!</p> <p><b>SK</b> Použite drevený podklad!!<br/>Přitlačte front, použijte ostrý vrták a prevrtajte miernym tlakom!</p> <p><b>RO</b> suport de lemn!<br/>Împingeți frontul, utilizați un burghiu ascuțit și perforați exercitând doar o presiune redusă!</p> <p><b>TR</b> Ahşap taban kullanın!<br/>Önden bastırın, keskin matkap ucu kullanın ve az basınç uygulayarak delin!</p> |
|--|---|

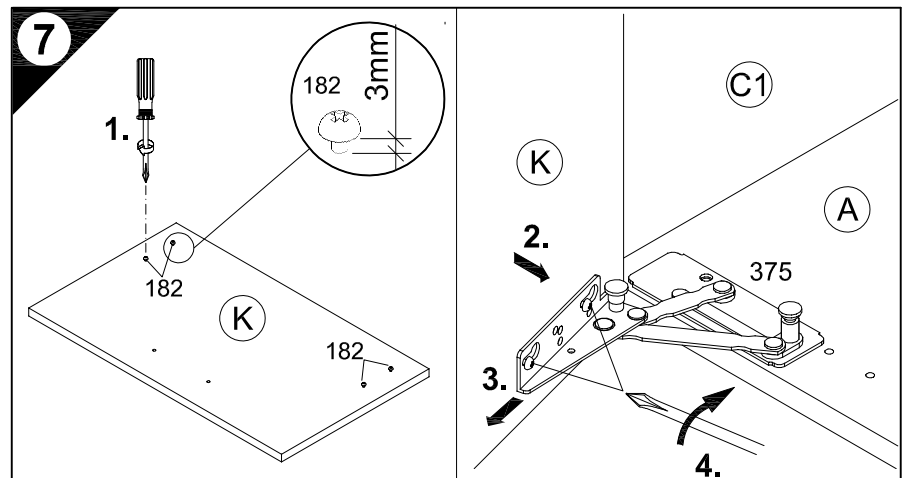
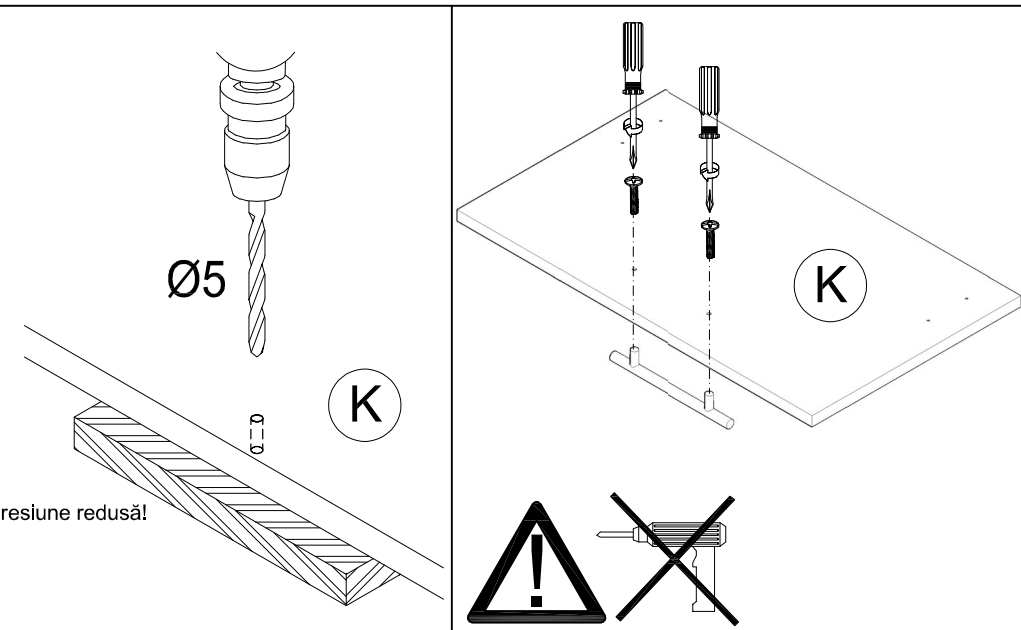
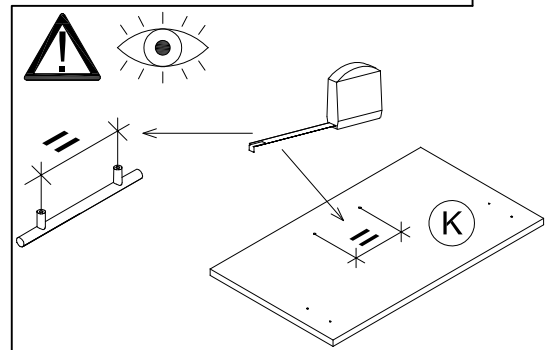

8

- |  |  |
|--|--|
| <p><b>D</b> Untergrund und Befestigungsmittel auf Eignung prüfen!</p> <p><b>GB</b> Check substructure and fixings for suitability!</p> <p><b>F</b> Contrôler si le support et les moyens de fixation sont bien adéquats !</p> <p><b>NL</b> Ondergrond en bevestigingsmateriaal op functionaliteit controleren!</p> <p><b>E</b> ¡Comprobar el suelo y los medios de fijación en cuanto a su aptitud!</p> <p><b>I</b> Controllare l'idoneità del fondo e del materiale di fissaggio!</p> <p><b>RUS</b> Основание и крепежный материал проверить на пригодность!</p> <p><b>PL</b> Podłoże oraz materiały do zamocowania sprawdzić na ich przydatność!</p> <p><b>H</b> Az alapfelületet és a rögzítő anyagokat megfelelőség szempontjából ellenőrizni kell!</p> <p><b>CZ</b> Přezkoušejte podklad a vhodnost upevňovacích prostředků!</p> <p><b>SLO</b> Preverite, če se ujemajo spodnja stran in pritrdilna sredstva!</p> <p><b>FIN</b> Tarkista alustan ja kiinnitysvälineiden sopivuus!</p> <p><b>S</b> Kontrollera att underlaget och fästmedlen är lämpliga!</p> <p><b>SK</b> Preverte vhodnosť podkladu a upevňovacích prostriedkov!</p> <p><b>RO</b> Verificați caracterul adecvat al suprafeței suport și al mijloacelor de fixare!</p> <p><b>TR</b> Zeminin ve bağlanı elementlerinin uygunluğunu kontrol edin!</p> |  |
|--|--|

9

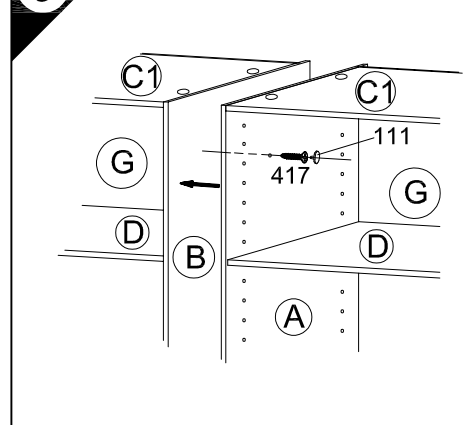

# Montageanleitung

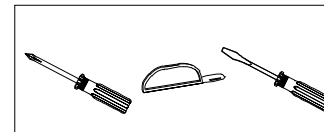

SO 180-...  
SO 242-...  
SO 278-...  
SOH 278-...  
SR-...

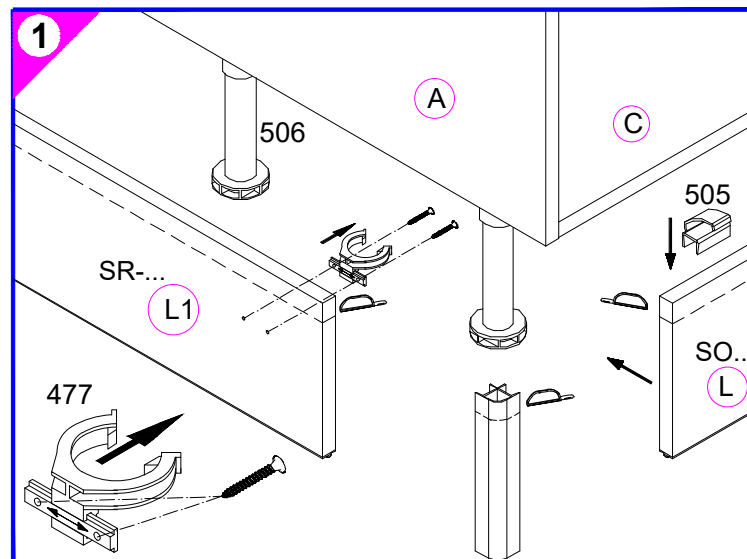
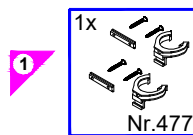

**OPTI  
FIT**

JAKA-BKL GmbH  
Jaka Straße 3  
D-32351 Stemwede-Wehdem

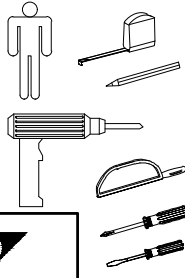

# Montageanleitung WAP-205

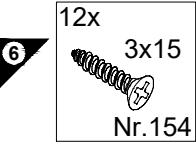
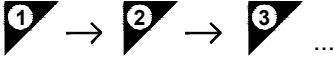
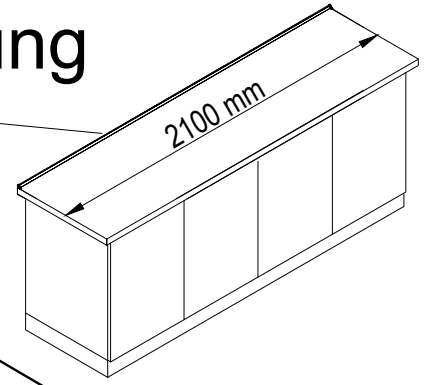
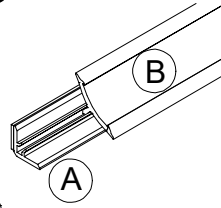
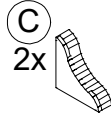

**Service-Hotline**  
**01805-678101**  
0,14€ pro Minute  
**++49 für Österreich**  
Auslandstarif pro Minute  
**service@jaka-bkl.de**  
voor Nederland en België  
**00800-40119350**  
**benelux@jaka-bkl.de**

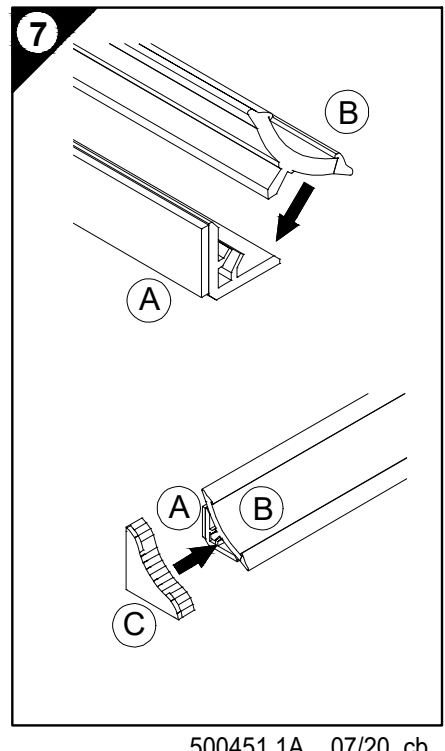
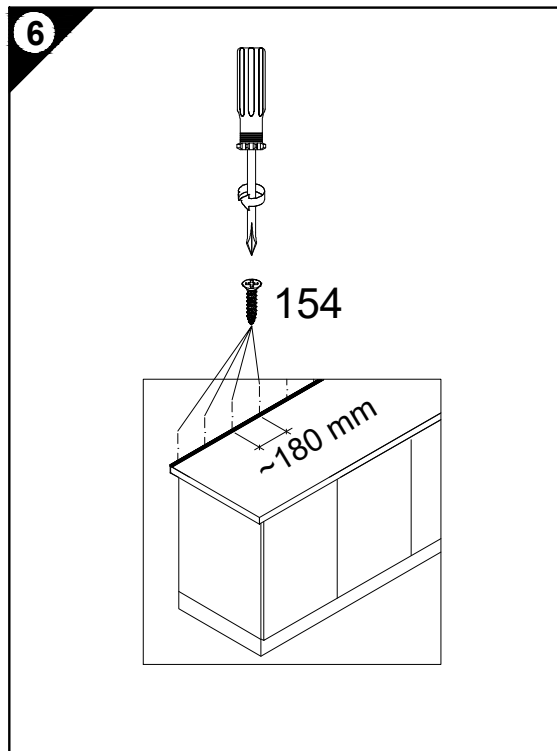
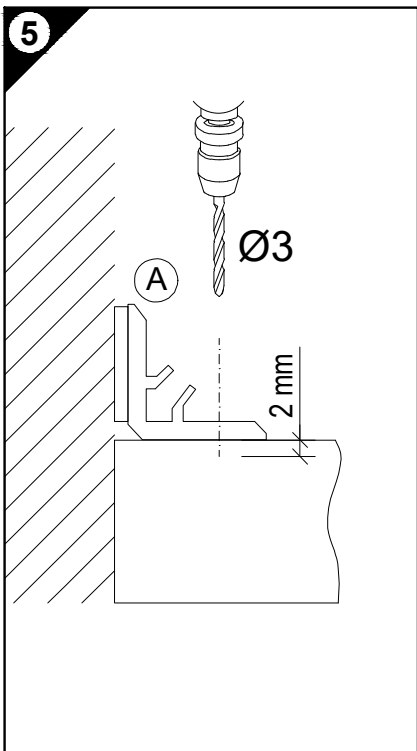
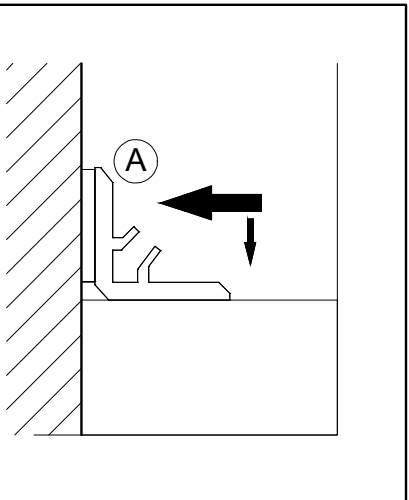
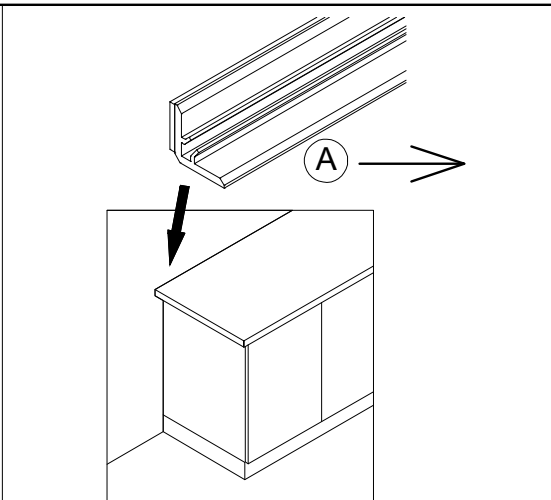
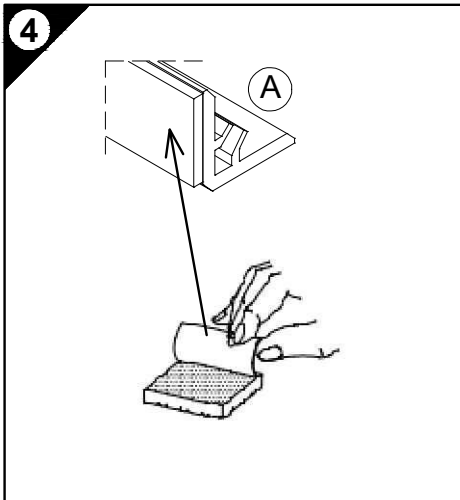
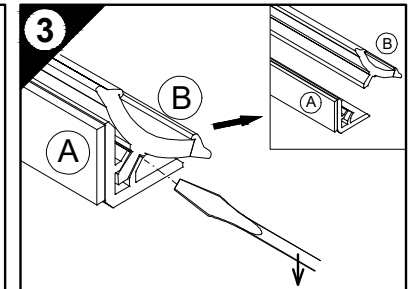
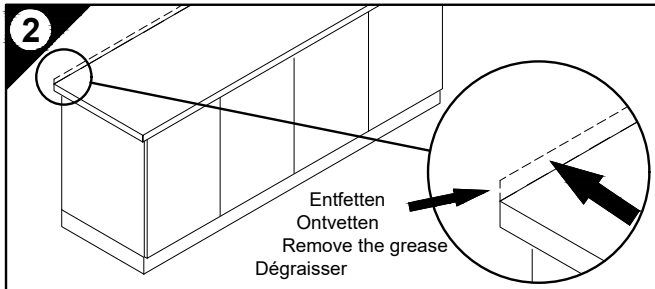
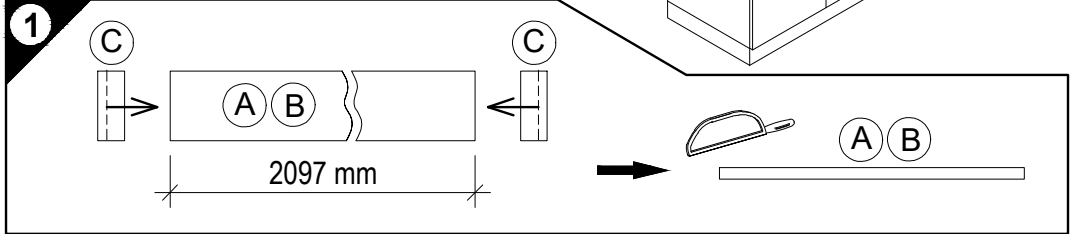

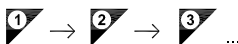
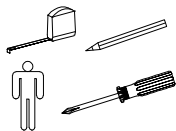
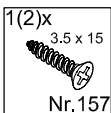
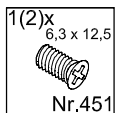
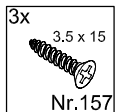
**OPTI  
FIT**JAKA-BKL GmbH  
Jaka Straße 3  
D-32351 Sternweide-Wehden**1****2**

**Service-Hotline**  
**01805-678101**  
0,14€ pro Min.  
**++49 für Österreich**  
Auslandstarif pro Min.  
**service@jaka-bkl.de**  
voor Nederland en België  
**00800-40119350**  
**benelux@jaka-bkl.de**

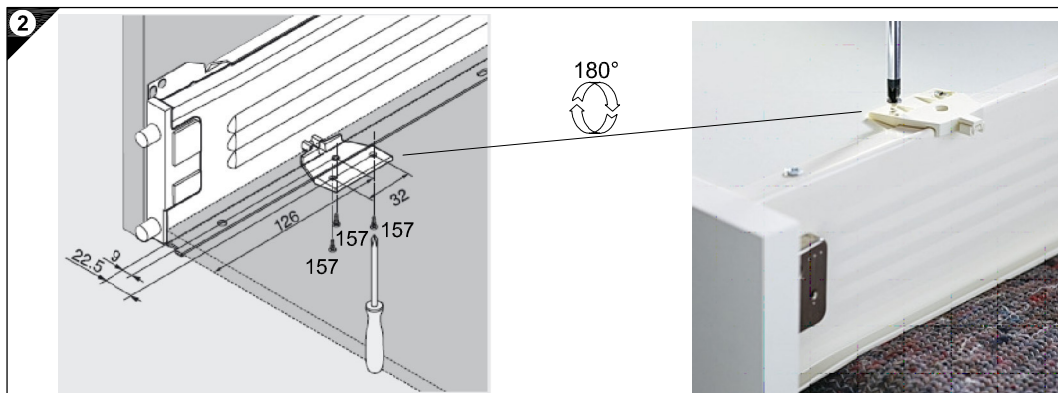
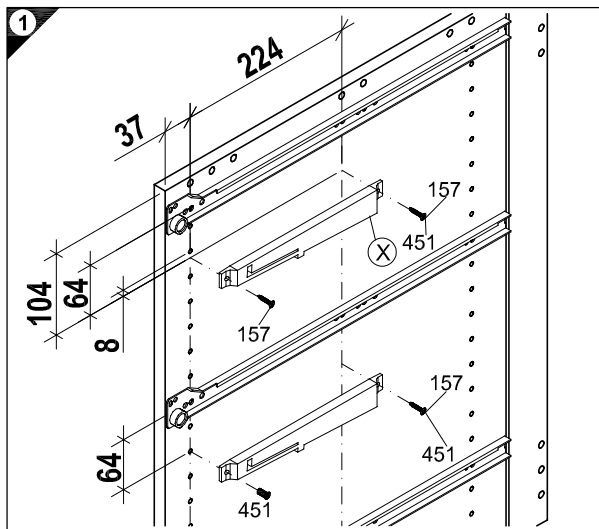

# Montageanleitung

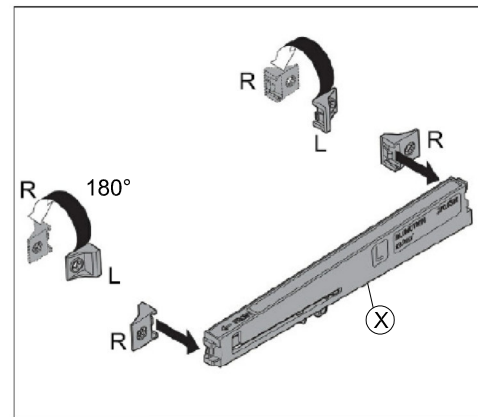

Ersatzteile/Spare parts/pièces de rechange/Reserveonderdelen/Piezas de recambio/Ricambi/Запасные части/Części zamiennie/pótkatárszek/Náhradní části/Nadomestni deli/varaosat/reservdelar/náhradné diely/Utilizati piese de schimb/Yedek parçalar



BLU-MT2

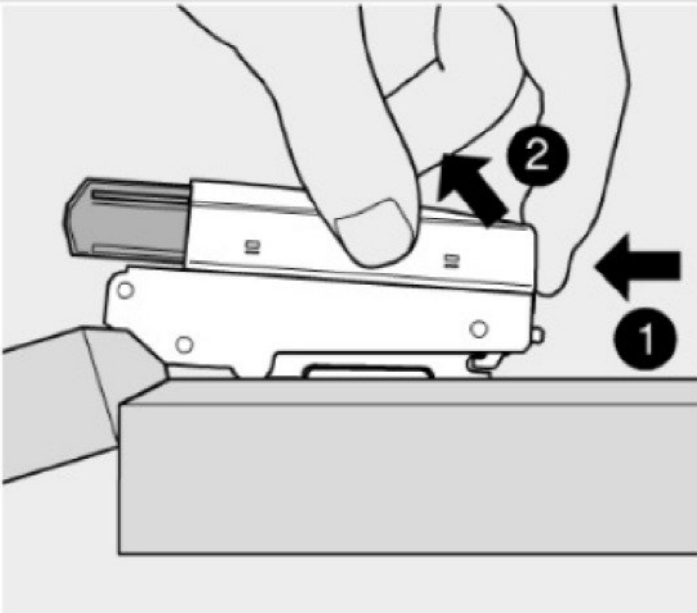
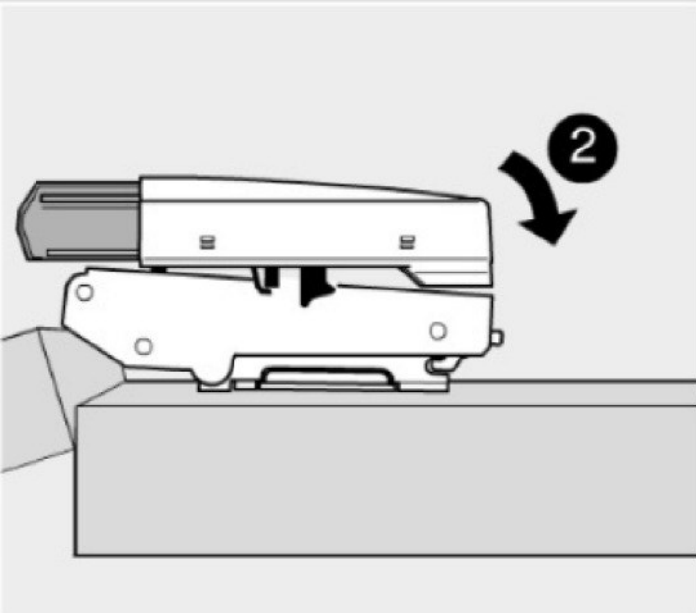
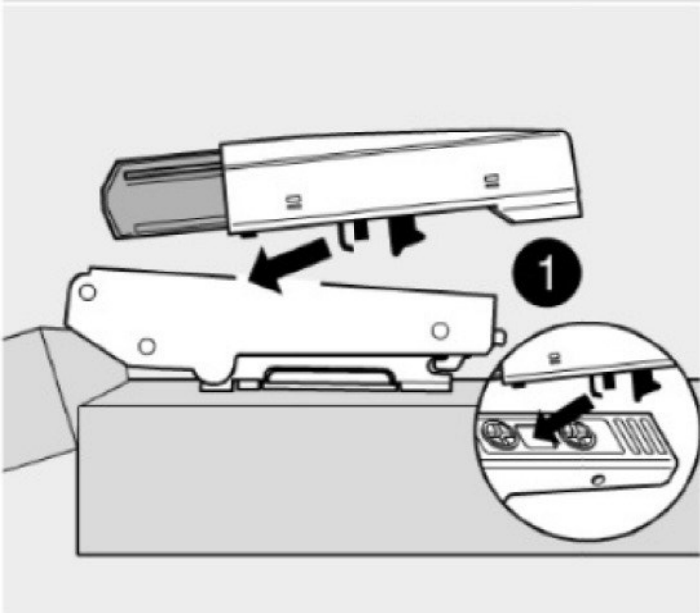

Montage

Demontage



# SERVICEKARTE

VH

Liebe Kundin, lieber Kunde,

obwohl wir unsere Möbel vor der Auslieferung einer eingehenden Endkontrolle unterziehen, kann es vorkommen, dass einmal ein Zubehörteil fehlt oder während des Transports beschädigt wird. Senden sie den Artikel bitte nicht zurück, sondern fordern sie einfach Ersatz für das Einzelteil bei unserer Kundenhotline an. Die Telefonnummern finden sie auf den Serviceseiten im Katalog.

Bitte benennen sie die Teile wie sie auf ihrer Aufbauanleitung angegeben sind. Fügen sie auch **Artikelnummer, Modellnamen und Farbnummer** bei. **Siehe Beispiel.**

Wir werden ihre Anforderung sofort bearbeiten und ihnen das Ersatzteil umgehend zusenden.

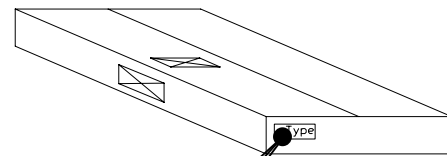
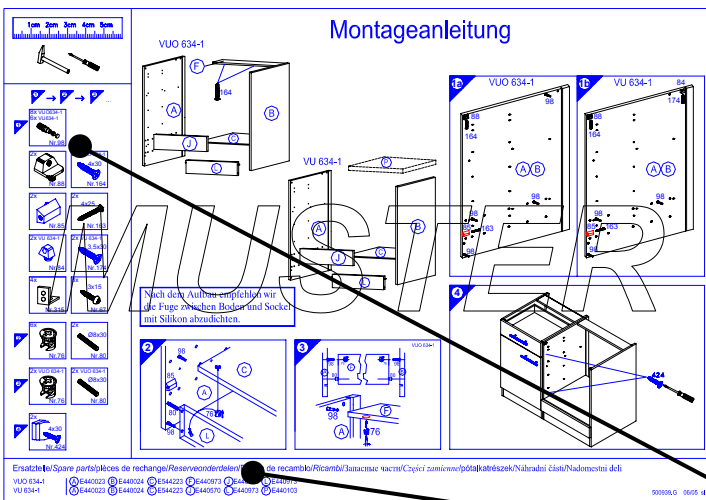

Muster - Bestellung		
Artikelnummer	123 456	
Modellname	Unterschrank VU634	
Farbe	TA 01	
Benötigte Ersatzteile:		
Bezeichnung	Nr.	Anzahl
Beschlagteil	98	2
Teil B	E 440 023	1

Bitte entnehmen sie die notwendige Ersatzteilnummer der Aufbauanleitung die zum Möbel gehört!

Kundendaten	
Kundennummer	
Name	
Vorname	
Strasse	
Haus-Nr.	
PLZ	
Ort	
Rechnungsdatum	
Tel. für Rückfragen	
Notizen:	

Ersatzteilbestellung		
Artikelnummer		
Modellname		
Farbe		
Benötigte Ersatzteile:		
Bezeichnung	Nr.	Anzahl
Grund der Ersatzteilanforderung:		

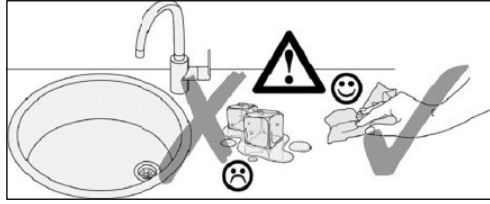
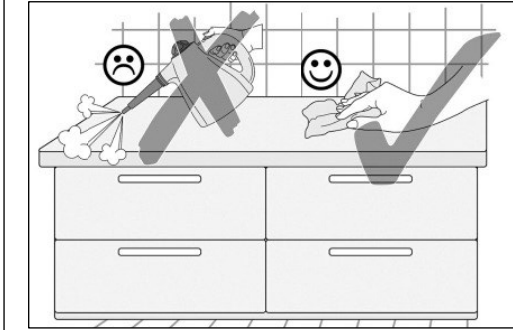

500823.1.A 04/15 sl

## D Pflegehinweise

**Kunststoff-Oberflächen:** Kunststoffbeschichtete Oberflächen/Fronten lassen sich mit handelsüblichen Reinigungsmitteln pflegen. Am besten geht das mit einem weichen Tuch, handwarmen Wasser und etwas Spülmittel. Verwenden Sie keine polierenden Reinigungsmittel oder harte Schwämme! Hartnäckige Flecken, wie Fettspritzer, Lack- oder Klebstoffreste, sind mit einem handelsüblichen Kunststoffreiniger zu beseitigen. Vor dem ersten Gebrauch dieser Mittel empfiehlt es sich, diese an einer nicht sichtbaren Stelle zu prüfen!

**Glänzende Fronten:** Diese Fronten nie trocken reinigen!  
Die Verwendung von schleifenden Reinigungsmitteln (Mikrofasertücher, Scheuerschwämme etc.) können zu erhöhter Bildung von Kratzern führen und sind kein Reklamationsgrund. Verwenden Sie daher am besten ein staubfreies Tuch oder ein feuchtes Fensterleder.

**Einbauspülen und Herdmüden:** Herdmüden, Herdmüden sowie alle nicht genannten Artikel aus rostfreiem Stahl pflegen Sie am besten mit einem Schwamm oder einem Wischtuch unter Verwendung von Spülmittel oder mit den bekannten Spezialpflegemitteln (Edelstahl-Polish). Bei Einbauspülen aus anderen Materialien wie Porzellan, Kunststoff, Acryl-Keramik sowie bei Edelstahlspülen mit/oder Spül- oder Reinigungsmittel verwenden.

**Glas-Keramik-Kochfelder:** Bitte beachten Sie außerdem die speziellen Pflegehinweise der Hersteller!

**Glas-Keramik-Kochfelder:** Hartnäckige Verschmutzungen, Kalk- und Wasserflecken sowie glänzenden Topflablack beseitigen Sie mit dem vom Hersteller empfohlenen Spezialreiniger (z.B. Cerafix, Stahlfix), fräsigbrannte Verkrustungen (Zucker, Salz oder zuckerhaltige Speisereste) entfernen Sie, in noch heilem Zustand, mit einem Glasschaber.

**Beachten Sie hierzu auch die Bedienungsanleitung des Geräteherstellers!**

**Griffe:** Verzichtigen Sie auf lösungsmittelhaltige und aluminiumschädigende Substanzen sowie auf Essigreiniger, da diese zu einer nicht mehr entfernbaren Fleckbildung führen können.

## NL Onderhoudsinstructies

**Kunststof-oppervlakken:** Oppervlakken/fronten met een kunststof coating kunnen met een gangbaar huishoudelijk reinigingsmiddel worden verzorgd. Dat gaat het beste met een zacht doekje, handwarm water en een beetje afwasmiddel. Gebruik geen polijstende reinigingsmiddelen of harde sponsjes! Hardnekkige vlekken, resten van lak of lijn, moeten met een gangbaar reinigingsmiddel voor kunststof worden verwijderd. Voor het eerste gebruik van dit middel is het aan te bevelen om dit op een niet zichtbare plek uit te proberen!

**Glanzende fronten:** Deze fronten nooit droog reinigen!  
Het gebruik van schurende reinigingsmiddelen (microvezeldoekjes, schuursponsjes etc.) kunnen tot snellere vorming van krassen leiden en zijn geen reden voor een reclamatie. Gebruik daarom het beste een stoffrijt doekje of een vochtige zeem.

**Inbouwgootstenen en kookplaten:** Inbouwgootstenen, kookplaten en alle niet genoemde artikelen van roestvast staal reinigen u het beste met een sponsje een vlieddoek met afwasmiddel of met de bekende speciale reinigers (v-s-rijger, metaal-polish). Bij gootstenen van andere materialen zoals porselein, kunststof, acryl-keramiek en bij gootstenen van edelstaal milde afwas- of reinigingsmiddelen gebruiken. Neem bovendien de speciale reinigingsinstructies van de fabrikanten in acht!

**Glaskeramische kookplaten:** Hardnekkig vuil, kalk- en watervlekken en glanzende slijfplekken van pannen verwijderd u met het door de fabrikant aanbevolen speciale reinigingsmiddel (bijv. Cerafix, Stahlfix). Aangekoekte en vastgebrande resten (suiker, zout of suikerhoudende voedselresten) verwijderd u, in nog hete toestand, met een glasschaber. Raadpleeg hiervoor ook de handleiding van de fabrikant van het apparaat!

**Grepen:** Gebruik geen oplosmiddelhoudende en aluminium beschadigende substanties en geen schoonmaakzijn omdat deze tot vlekken kunnen leiden die niet meer te verwijderen zijn.

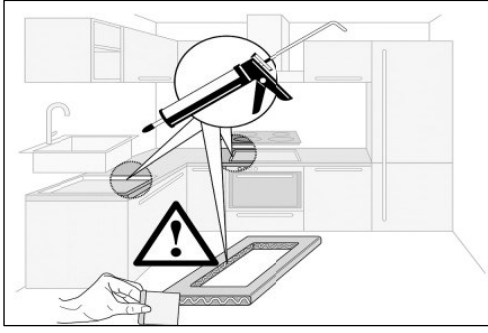
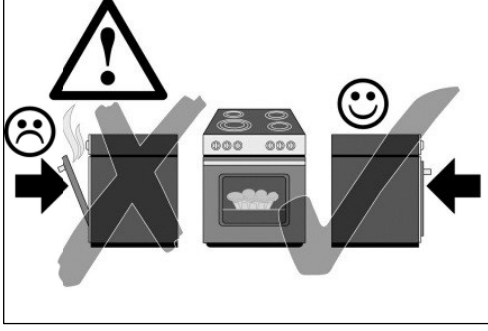
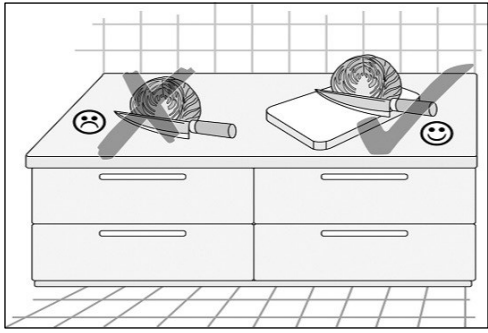

## GB Care instructions

**Synthetic Surfaces:** Synthetic finishes on surfaces/fronits can be cared for with common household cleaners. It's best to use a soft cloth, hand warm water and a little washing-up liquid. Do not use any polishing cleaners or hard sponges! Stubborn marks, such as grease splashes, paint or adhesive residues can be removed with common, commercially available synthetic materials cleaners. However, it is recommended that these be tested on an inconspicuous area before using them for the first time!

**Gloss Fronts:** Never clean these fronts in the dry state!  
The use of abrasive cleaning materials (microfibre cloths, scrubbing sponges, etc.) can lead to increased incidence of surface scratching and are not accepted grounds for complaints. Therefore using a dustfree cloth or a damp chamomils is best.

**Fitted Sink Units and Hobs:** Fitted sink units and all other articles made of stainless steel are best cleaned using a sponge or a fleece cloth with a washing-up liquid or known specialty cleaner (stainless steel cleaner, metal polish). Use mild washing-up or cleaning liquids on fitted sinks made of other materials, such as porcelain, synthetic material, acrylic ceramic as well as stainless steel. In addition, make sure to always follow the specific care instructions provided by the respective manufacturer!

**Ceramic Glass Hobs:** Stubborn marks, limescale and water spots and stippy marks left by pots are best removed with special cleaners as recommended by the manufacturer. Use a glass scraper to remove burn-on marks (sugar, salt or food splashes containing sugar) write soft hot.

**Handles:** Please also refer to the operating instructions provided by the appliance manufacturer!

Avoid using substances containing solvents or which are harmful to aluminium, as well as cleaners containing vinegar, as these can cause permanent discoloration.

## F Conseils d'entretien

**Revêtements en plastique :** Les revêtements / fronts en plastique peuvent être entretenus au moyen d'un produit de nettoyage ménager courant. L'idéal est d'utiliser un chiffon doux, de l'eau tiède et un peu de produit pour la vaisselle. N'utilisez pas de produit de polissage ou d'éponges dures ! Éliminez les taches tenaces, telles que les projections de graisse et résidus de vernis ou de colle, au moyen d'un produit de nettoyage pour le plastique courant. Avant la première utilisation de ce produit, il est recommandé de tester celui-ci à un endroit dissimulé !

**Fronts brillants :** Ne nettoyez jamais ces fronts à sec !  
L'utilisation de produits de nettoyage abrasifs (chiffons en microfibre, éponges abrasives, etc.) peut entraîner la formation accrue de rayures et ne peuvent justifier aucune réclamation. L'idéal est donc d'utiliser un chiffon non-pelucheux ou une peau de chamomille humide.

**Éviers encastrés et tables de cuisson :** Les éviers encastrés et tables de cuisson, ainsi que tous les éléments en acier inoxydable n'étant pas cités ici doivent être entretenus avec une éponge ou une peau de chamomille imprégnées de produit vaisselle ou d'un produit spécifique (détergent inox, polish métal). Les éviers encastrés fabriqués dans d'autres matériaux, tels que de la porcelaine, du plastique, de la céramique acrylique, ainsi que les éviers en acier inoxydable doivent être nettoyés au moyen de produit vaisselle ou détergent doux. Respectez également les consignes d'entretien spécifiques du fabricant !

**Plaques vitrocéramiques :** Éliminez les taches tenaces, les taches de calcaire et d'eau, ainsi que les traces brillantes laissées par les casseroles au moyen du produit spécial recommandé par le fabricant (par ex. Cerafix, Stahlfix). Éliminez les restes carbonisés (sucre, sel ou aliments sucrés) encore chauds au moyen un radloir. Respectez ici les instructions du fabricant de l'appareil!

**Poignées :** N'utilisez pas de substances à base de solvant et décolorant l'aluminium ou produits à base de vinaigre ; ceux-ci peuvent causer des taches indélébiles.

