

090-9119-05062024

090-9119



When the assembly finished it will look as seen here.
If you need you can use as reference

Step 1 Head Pipe Assembly

Assembly The Head Frame To The Pipes
By Using M8x25 Screws. Use The Allen Key.

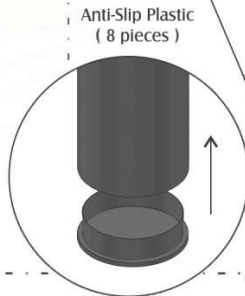
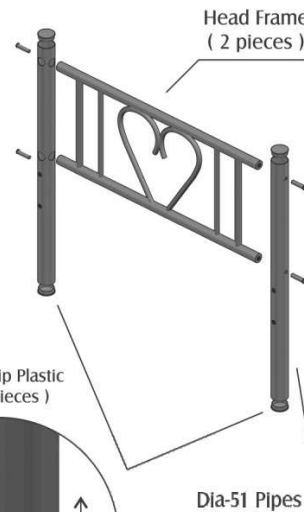

Step 2 Head Side And Back Rail Traverse Assembly

After The Installation Of Head, Assembly The Side Traverse To The Dia-51 Pipes By Using M8x5 Screws From 4 Points
Insert the back rail into the holes

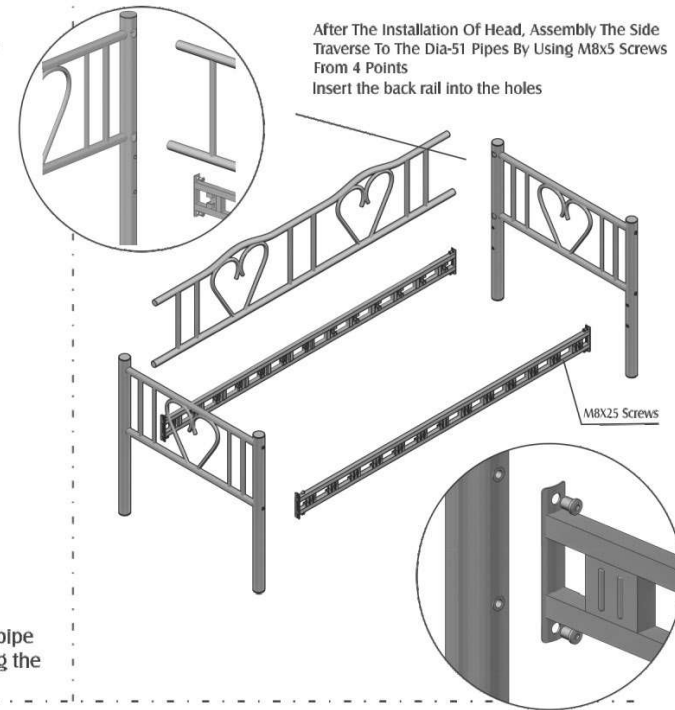

Step 3 Assembly Of Stick

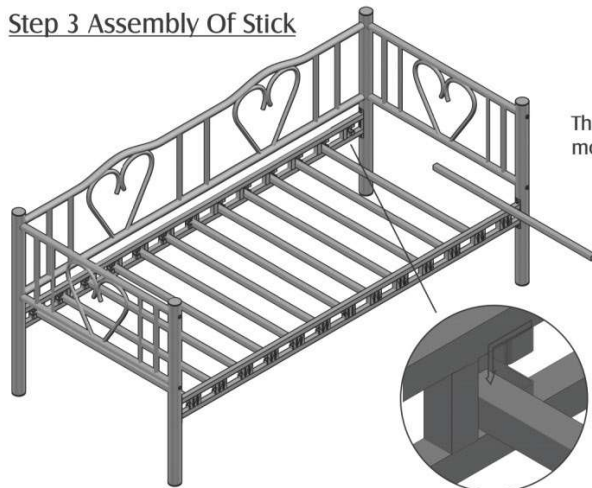

The Sticks, as seen in the 'detail' will be mounted, follow the arrow.

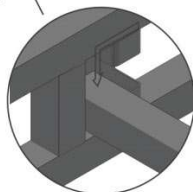

Finally the assembly finished
We hope you us it for good days

Durable Metal Construction
Electrostatic Powder Coating
Easy Assembly



Assembly Takes About
6 Minutes
With Two People

One of the ergonomic features of iron bunk beds is the ladder parts.
With the designs that offer different options up to a maximum carrying capacity of 130 kg, going up and down from the stairs to the bunk bed continue both comfortably and safely.
Another factor that allows metal bunk beds to be comfortable is the adoption of a solid and frequent centering method during workmanship.
In this way, it becomes easier to keep the poles stable and prevents the bedsteads from swinging during the movements of the users during sleep.
It is very easy to assemble and disassemble with the help of the designs when you move to a new place.
The preferred paint technology in steel bunk bed models is the electrostatic powder paint method. The paint, which offers the advantage of long-term use, has qualities that can prevent being affected by external factors such as dust, humidity and heat.
You can easily choose the one that suits your taste among the color options such as light gray, khaki and cream for metal bunk beds that affect the decoration style of the rooms.

Heinz Hofmann GmbH
Röthenstr. 3+5
D-96247 Michelau
Mail: info@ghm24.de
Tel.: +49 957197410