

ASSEMBLY INSTRUCTION

Item Number: WF324380 / WF324382

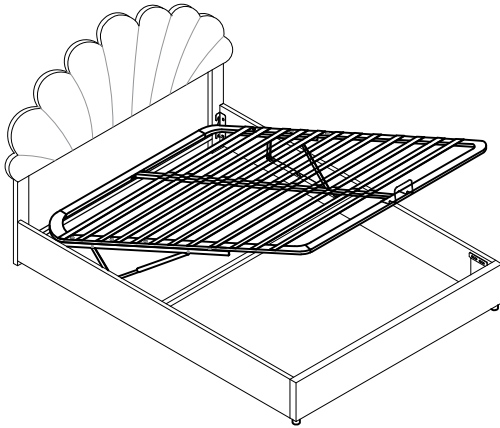







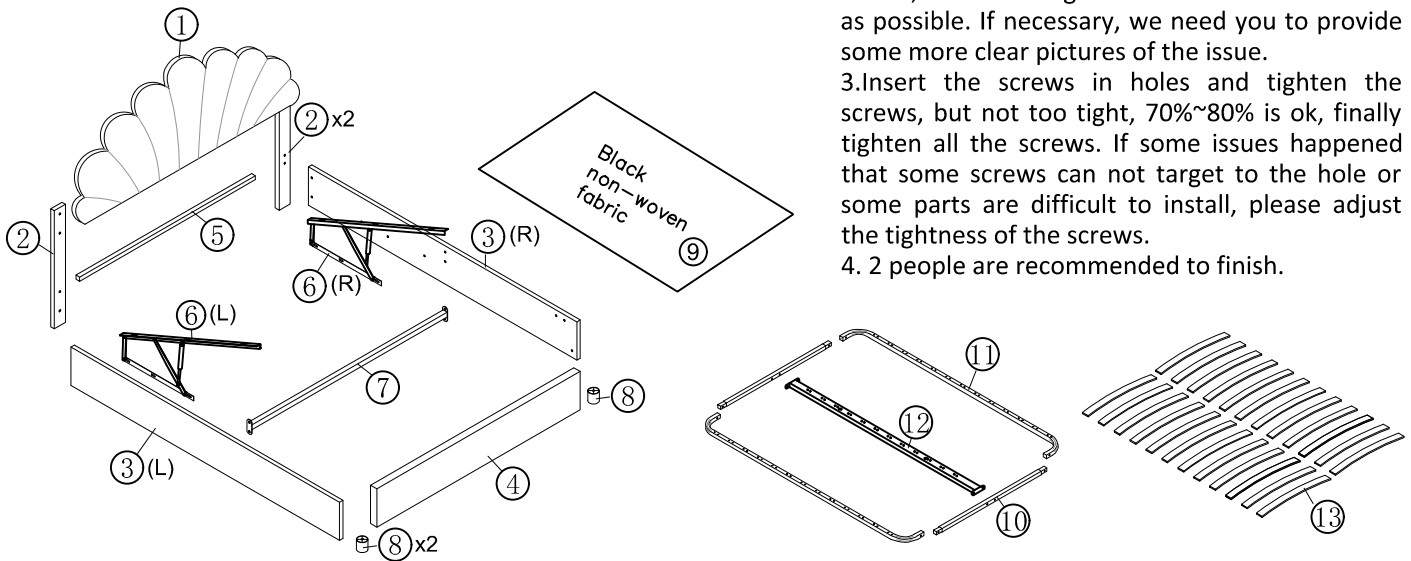





Upholstered Bed: 140x200



TIPPS





1. This set comes in 3 boxes. If you don't receive a full 3 boxes, please contact our customer service.
2. Please read the instructions fully before assembly. These instructions include important information which could ensure correct assembly. We have been working on providing high quality products for you. However, in the rare instance that your product is defective, missing parts or there are some issues, please don't hesitate to contact our customer service to submit parts requirements, assembly suggestion, or warranty claims, and we will give the best solution as soon as possible. If necessary, we need you to provide some more clear pictures of the issue.
3. Insert the screws in holes and tighten the screws, but not too tight, 70%~80% is ok, finally tighten all the screws. If some issues happened that some screws can not target to the hole or some parts are difficult to install, please adjust the tightness of the screws.
4. 2 people are recommended to finish.

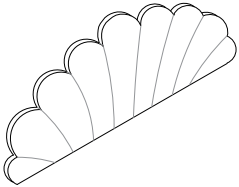

Parts List			Hardware List		
NO	ITEM	QTY	NO	ITEM	QTY
1	Head board	1	A	Allen Key 	1
2	Head board legs	2	B	Bolts (M8x45mm) 	18
3	Siderails	2	C	Hinge 	2
4	Foot board	1	D	Bolts (M8x18mm) 	38
5	Head board cross bar	1	E	Little "7" Connector 	2
6	Gas lift	2	F	Metal Corner 	2
7	Cross bar	1	G	Nails (M4x50mm) 	2
8	Bed legs	2	H	"7" Connector 	1
9	Non woven fabric	1	I	Nuts 	4
10	Metal frame cross bar	2	J	Spanner 	1
11	Metal frame side bar	2	K	Nuts 	14
12	Metal frame middle bar	1	L	Middle slats cap 	12
13	Slat	24	M	End slats cap 	24
			N	Stopper 	1
			O	Three hole iron 	2

Part List

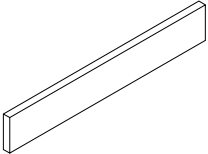
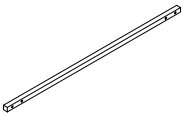
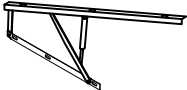
Hardware List+WF324380

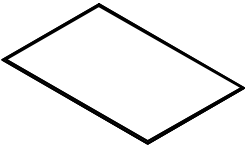
<p>1</p>  <p>Head board -1pc</p>	<p>2</p>  <p>Head board legs -2pcs</p>	<p>4</p>  <p>Foot board-1pc</p>
<p>5</p>  <p>Head board cross bar-1pc</p>	<p>6</p>  <p>Gas lift -2pcs</p>	<p>8</p>  <p>Legs-2pcs</p>
<p>9</p>  <p>Non woven fabric -1pc</p>		

Part List

WF324382

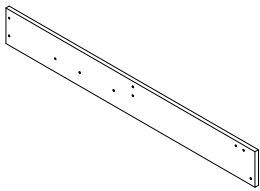
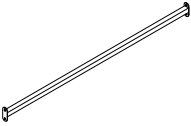
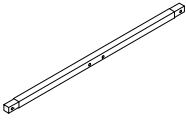
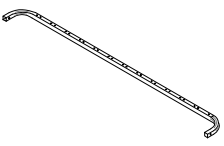
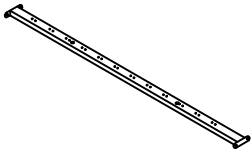
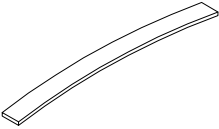

<p>3</p>  <p>Side rails-2pcs</p>	<p>7</p>  <p>Cross bar -1pc</p>	<p>10</p>  <p>Metal frame cross bar-2pcs</p>
<p>11</p>  <p>Metal frame side bar-2pcs</p>	<p>12</p>  <p>Metal frame middle bar-1pc</p>	<p>13</p>  <p>Slat-24pcs</p>

Attention: Do not tighten the screws before completing the entire installation. If you have any difficulty with the installation process, please feel free to contact us.

Step 1

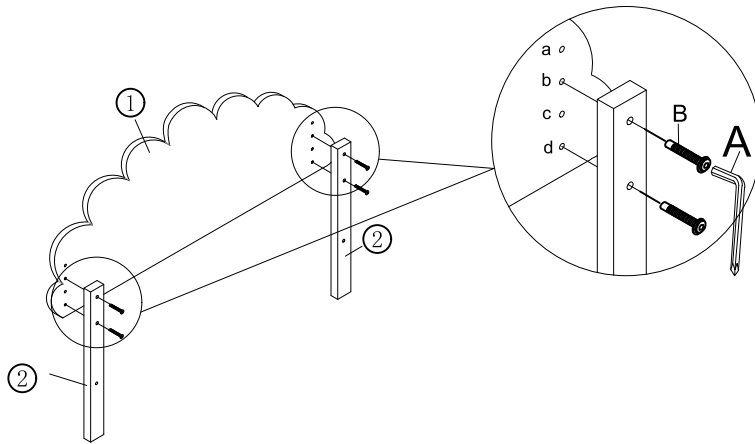
Fix the Headboard legs ② to the Headboard ① with Bolt B by using Allen key A. You can choose the holes a and c or b and d. (Befestigen Sie die Kopfteilbeine ② am Kopfteil ① mit Bolzen B mit Inbusschlüssel A. Sie können die Löcher a und c oder b und d wählen.)





A Allen Key	B Bolts x 4
	 M8X45mm

Step 2

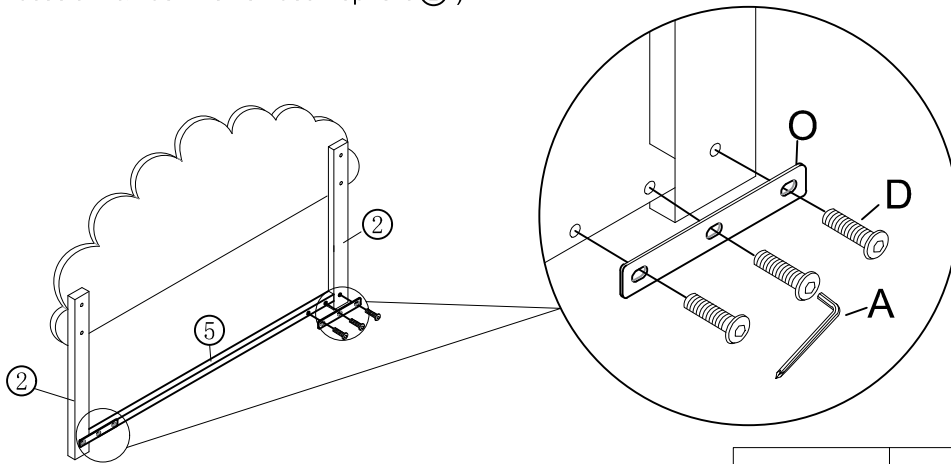
Fix the Headboard cross bar ⑤ to the Headboard legs ② with Bolt D and Three hole iron O by using Allen key A. (Befestigen Sie die Querstange ⑤ des Kopfteils mit den Schrauben D und dem Dreilochisen O unter Verwendung des Inbusschlüssels A an den Beinen des Kopfteils ②.)





A Allen Key	D Bolts x 6	O Three hole iron x2
	 M8X18mm	

Step 3

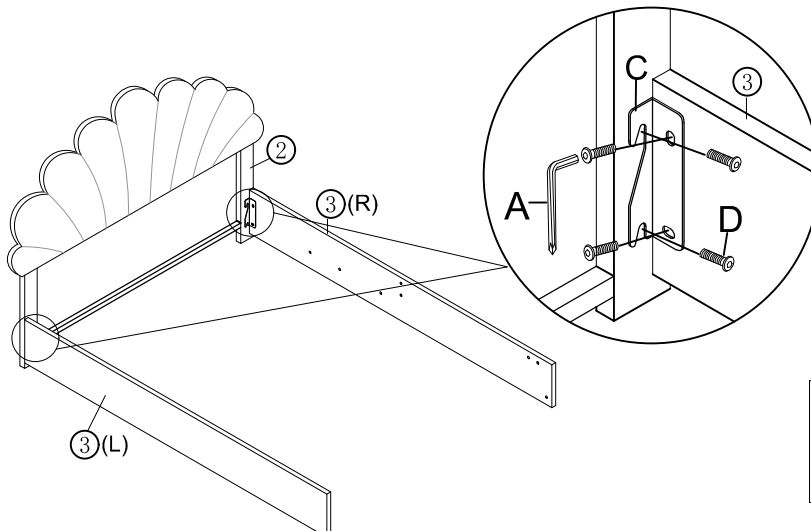
Fix the side rails ③ to the head board legs ② with Bolts D and Hinges C by using Allen key A. (Befestigung der Seitenschienen ③ an den Beinen des Kopf Bretts ② mit Schrauben D und Scharnieren C mit Inbusschlüssel A.)





A Allen Key	C Hinge x2	D Bolts x 8
		 M8X18mm

Step 4

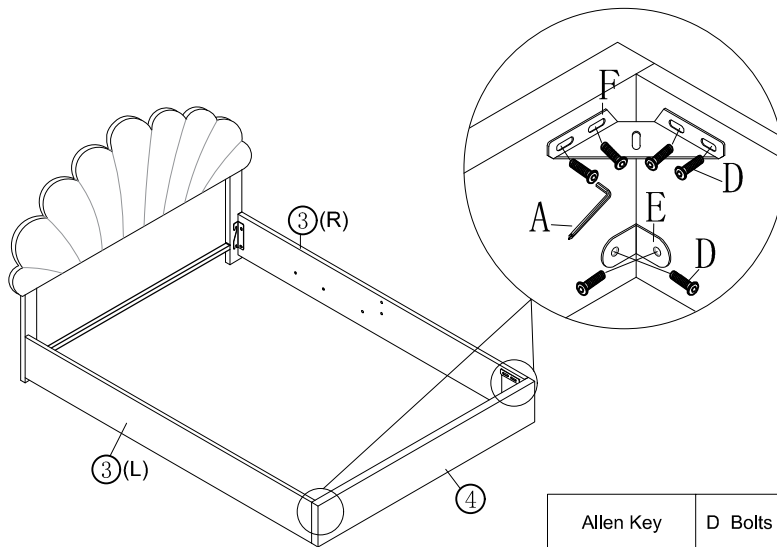
Fix the Siderails ③ to the footboard ④ with Metal corner F, Little "7" Connector E and Bolt D by using Allen key A.
 (Befestigen Sie die Seitenschienen ③ mit der Metallecke F, dem kleinen "7"-Verbindungsstück E und den Schrauben D mit dem Inbusschlüssel A am Trittbrett ④.)

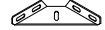

Allen Key 	D Bolts x 12  M8X18mm	E Little "7" Connector x 2 	F Metal Corner x 2 
--	---	---	---

Step 5

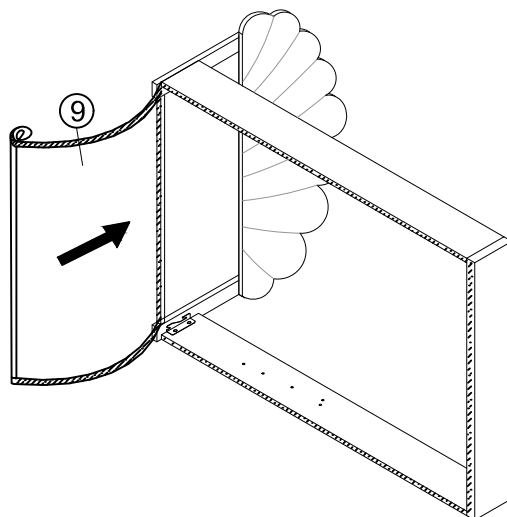

Stick the black non-woven fabric ⑨ to the bottom of bed.
 (Kleben Sie den schwarzen Vliesstoff ⑨ auf den Boden des Bettes.)

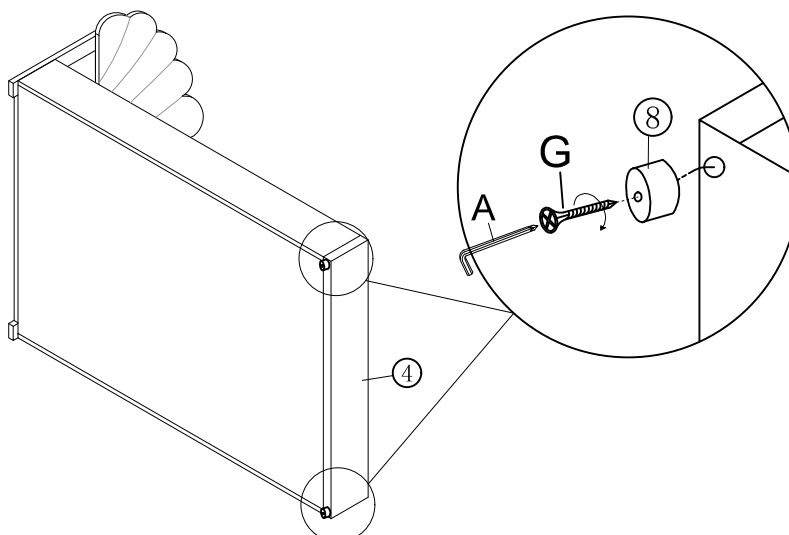

Step 6

Fix the legs ⑧ to the footboard ④ with nails G by using electric drill or screw driver
 (Befestigen Sie die Beine ⑧ mit Nägeln G am Trittbrett ④ mit Elektrobohrer oder Schraubendreher.)







A Allen Key 	G Nails x2  M4X50mm
--	--

Step 7

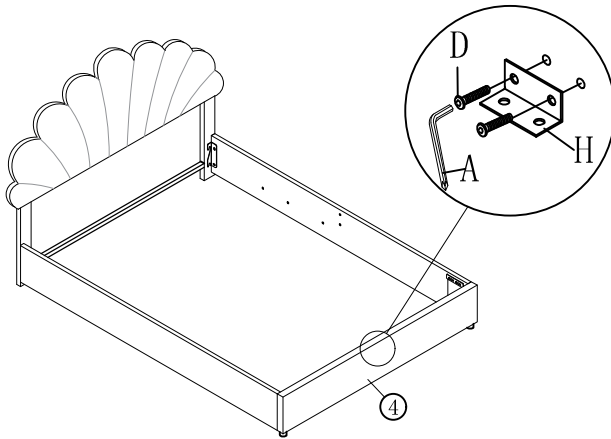
Fix the "7" Connector H to the footboard ④ with Bolt D by using Allen Key A.

(Befestigen Sie den "7"-Anschluss H mit den Schrauben D und dem Inbusschlüssel A am Trittbrett ④.)







Allen Key 	D Bolts x 2  M8X18mm	H "7" Connector x 1 
---	---	--

Step 8

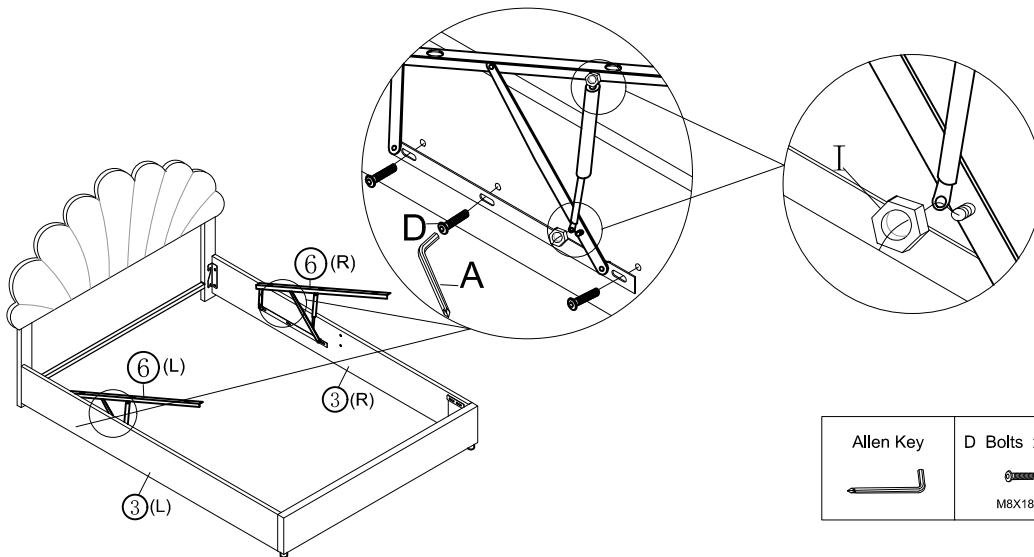
Fix the gas lifts ⑥ to the Siderails ③ with Bolts D by using Allen Key A or electric drill. fix the gas bar to the gas lifts ⑥ with Nuts I.

(Befestigen Sie die Gasdruckfedern ⑥ an den Seitenplatte ③ mit den Schrauben D, indem Sie den Inbusschlüssel A oder eine elektrische Bohrmaschine verwenden. Befestigen Sie die Gasstange mit den Mutter I an den Gasdruckfedern ⑥.)



Allen Key 	D Bolts x 6  M8X18mm	I Nuts x 4 
--	---	---

NOTICE:

The hole on the gas list is oval, please make sure that Please ensure that the installation positions on the left and right are roughly the same, if you accidentally install the gas lift one side to the front and the other to the back, which affects your use, you can write it down and reinstall it.

Achtung:



Das Loch in der Gasliste ist oval. Bitte stellen Sie sicher, dass die Einbaupositionen links und rechts ungefähr gleich sind. Wenn Sie den Gaslift versehentlich auf einer Seite nach vorne und auf der anderen nach hinten installieren, was sich auf Ihre Nutzung auswirkt, können Sie es aufschreiben und neu installieren.

Step 9

Fix the cross bar ⑦ to the Siderails ③ with Bolts D by using Allen Key A.

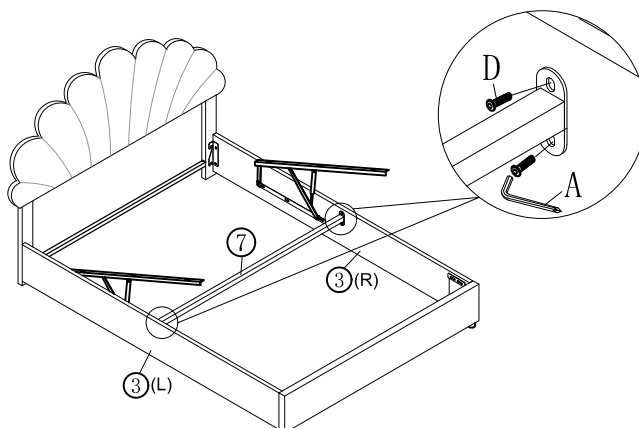
(Befestigen Sie die Querstange ⑦ mit den Schrauben D und dem Inbusschlüssel A an den Seitenschienen ③.)



Allen Key 	D Bolts x 4  M8X18mm
--	---

Step 10

Assemble the slats frame with Bolts B and Nuts K by using Spanner J and Allen Key A.
 (Montieren Sie den Lamellenrahmen mit den Schrauben B und Muttern K unter Verwendung des Inbusschlüssels A und des Schraubenschlüssels J.)

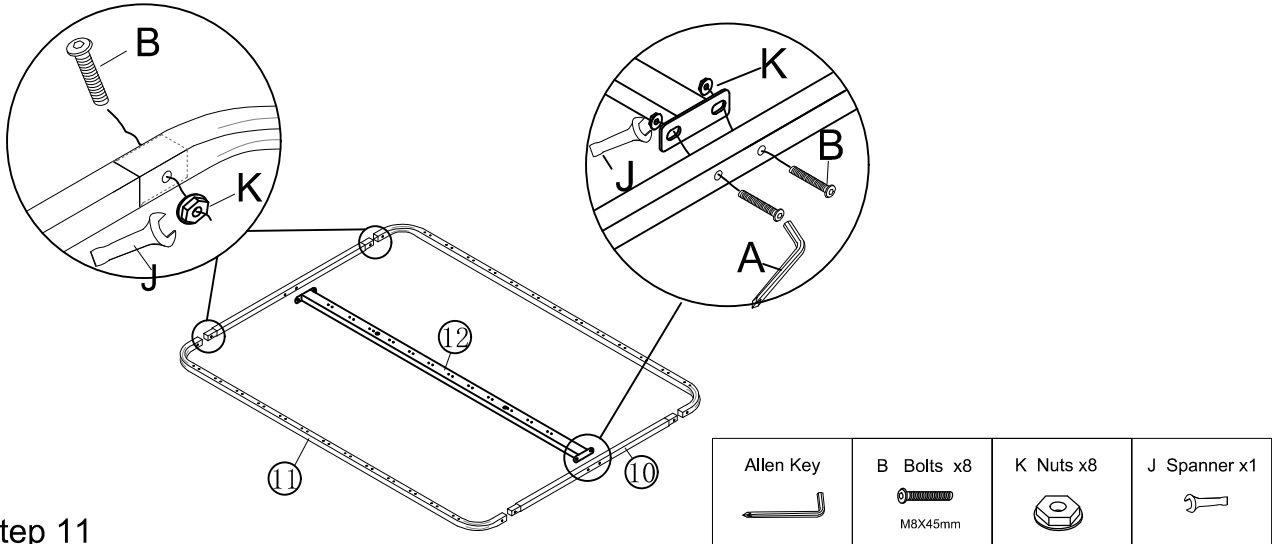

Step 11

Assemble the slats into the assembled slats frame with middle slats cap L and end slats cap M.
 (Montieren Sie die Lamellen mit der mittleren Lamellenkappe L und der Endlamellenkappe M in den zusammengebauten Lamellenrahmen.)

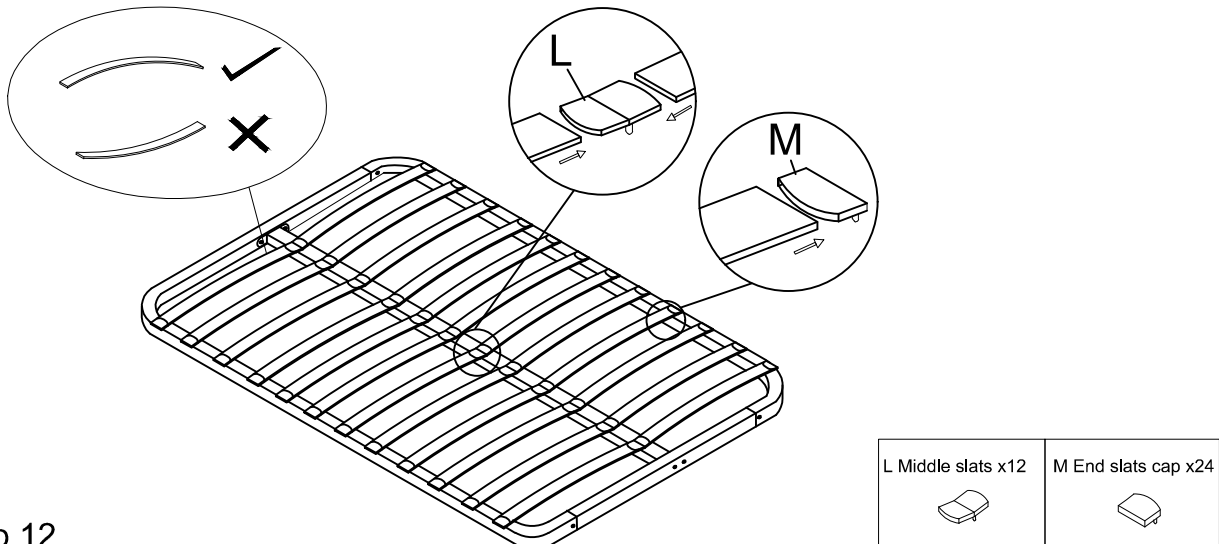

Step 12

Assemble the slats frame to the gas lifts ⑥ with Bolts B and Nuts K, put the stopper N in the end of the slat frame.
 (Befestigen Sie den Lattenrahmen mit den Schrauben B und Muttern K an den Gasfedern ⑥, setzen Sie den Stopper N am Ende des Lattenrahmens ein, dann ist der Zusammenbau abgeschlossen. Jetzt ziehen Sie bitte alle Beschläge fest und genießen Sie Ihr Bett.)

