

CALYPSO V
8141/2500/8300
8100/2500/8142

- | | | | |
|-----------|--|-----------|---|
| D | MONTAGEANLEITUNG
BEDIENUNGSANLEITUNG | GB | ASSEMBLY INSTRUCTIONS
INSTRUCTION MANUAL |
| NL | HANDLEIDING VOOR DE MONTAGE
GEBRUIKSAANWIJZING | PL | INSTRUKCJA MONTAŻU
INSTRUKCJA OBSŁUGI |
| TR | MONTAJ TALIMATI
KULLANIM KLAVUZU | RU | ИНСТРУКЦИЯ ПО МОНТАЖУ
ИНСТРУКЦИЯ ПО ЭКСПЛУАТАЦИИ |
| RO | INSTRUCȚIUNI DE INSTALARE
INSTRUCȚIUNI DE UTILIZARE | IT | ISTRUZIONI DI MONTAGGIO
MANUALE DI ISTRUZIONI |
| FR | NOTICE DE MONTAGE
MANUEL INSTRUCTIONS | SK | MONTÁŽNY NÁVOD
NÁVOD NA POUŽITIE |
| HU | KÖZGYŰLÉS UTASÍTÁSOK
KEZELÉSI UTASÍTÁS | CZ | MONTÁŽNÍ NÁVOD
NÁVOD K POUŽITÍ |
| SI | NAVODILA ZA MONTAŽO
NAVODILA ZA UPORABO | PT | INSTRUÇÕES DE MONTAGEM
MANUAL DO USUÁRIO |
| ES | INSTRUCCIONES DE MONTAJE
MANUAL DEL USUARIO | HR | UPUTE ZA MONTAŽU
UPUTE ZA UPOTREBU |

F/B

230613

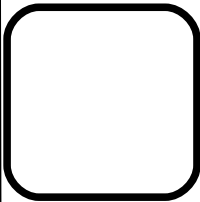
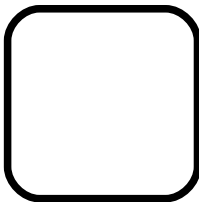

0019

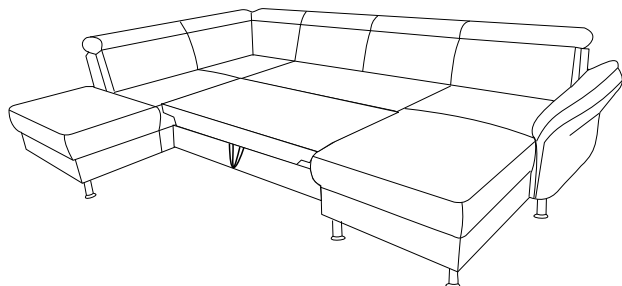
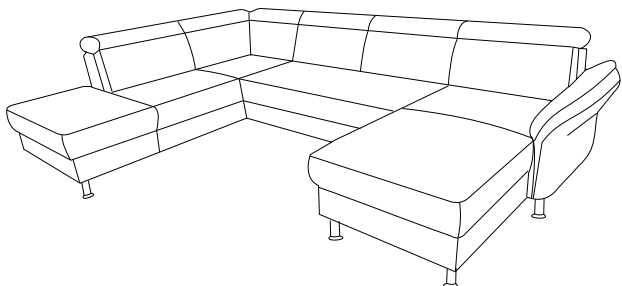

0019

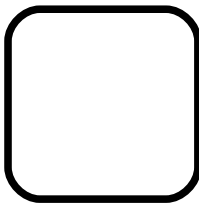
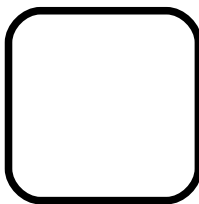

0090

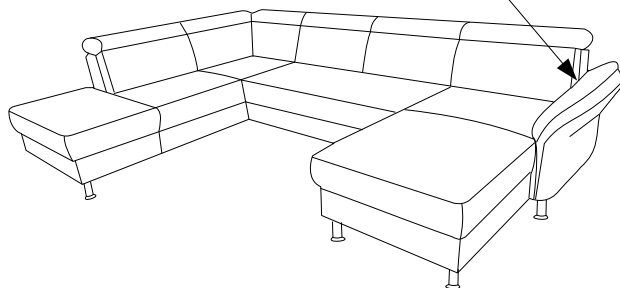
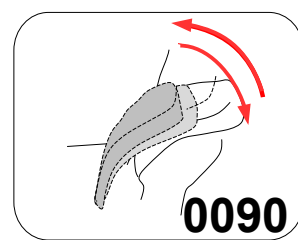
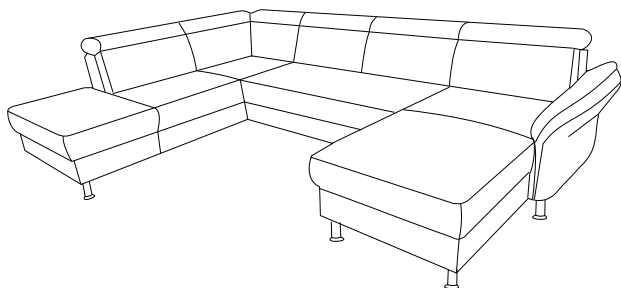

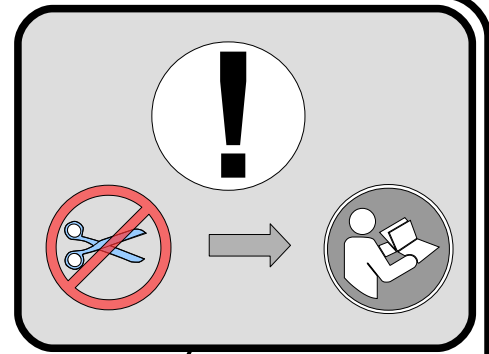
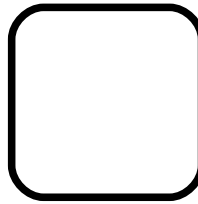
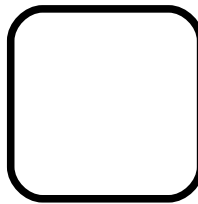

0089

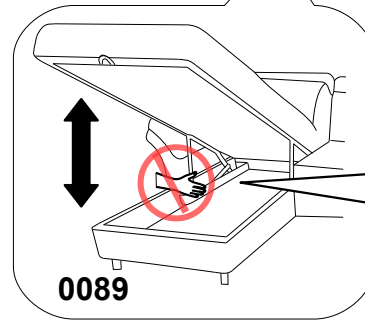
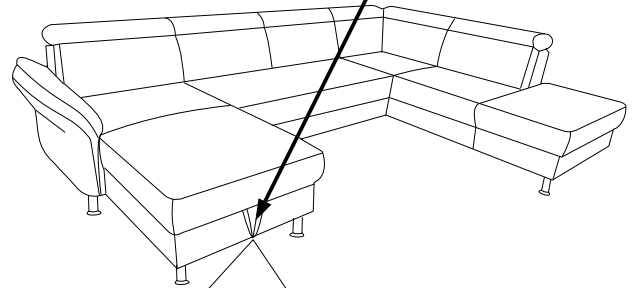
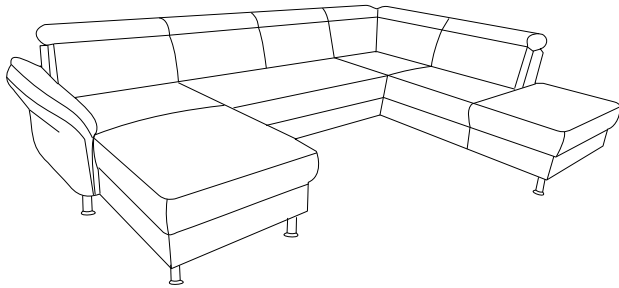

0089

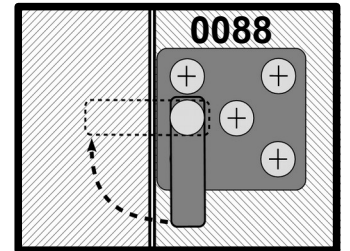
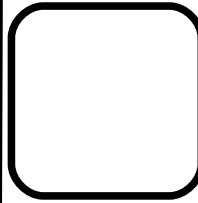
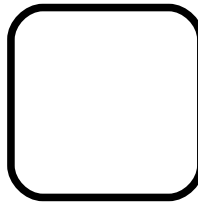

0088

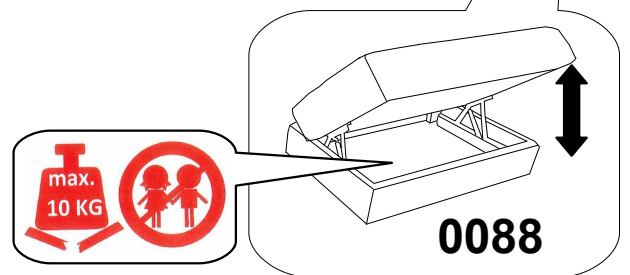
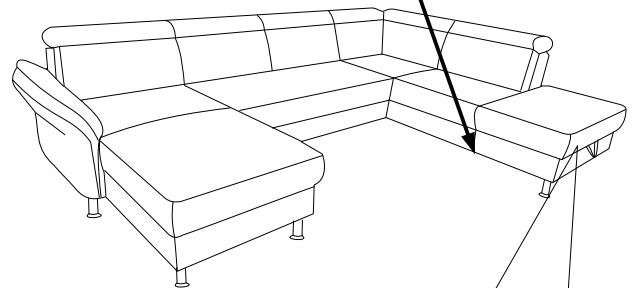
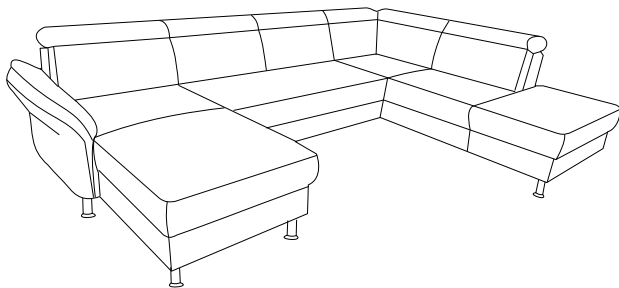

0088

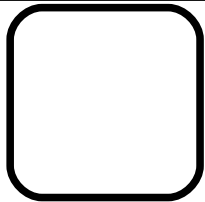
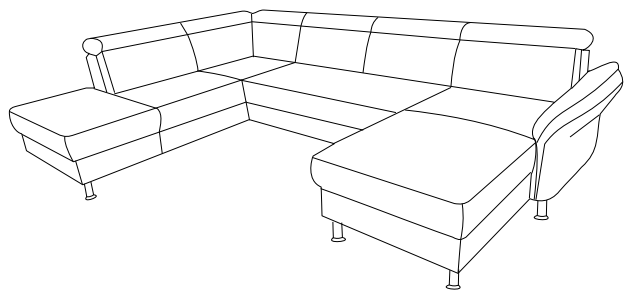
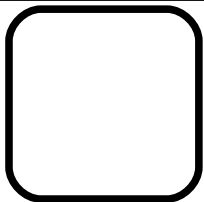

0064

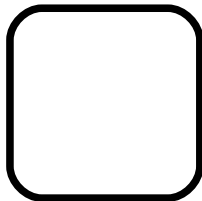
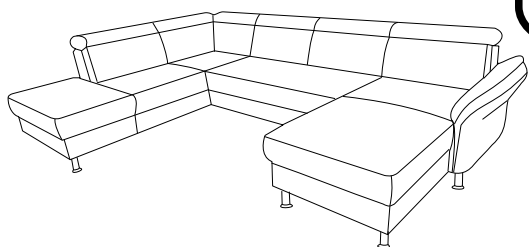
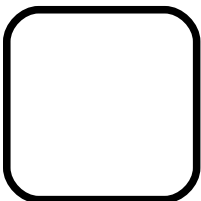
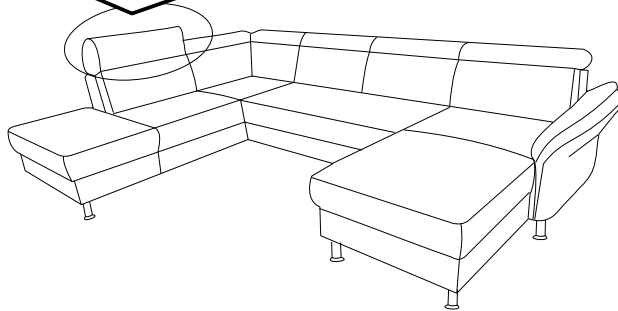
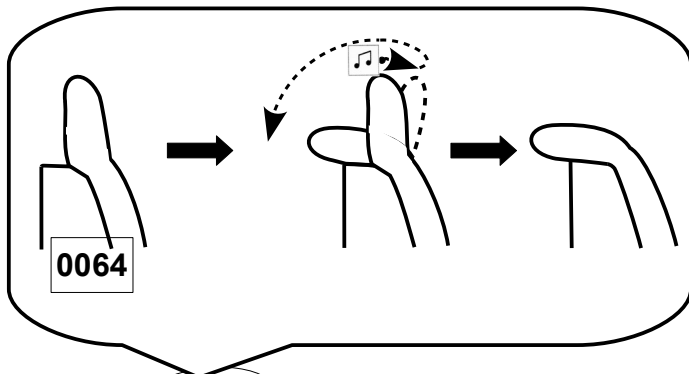
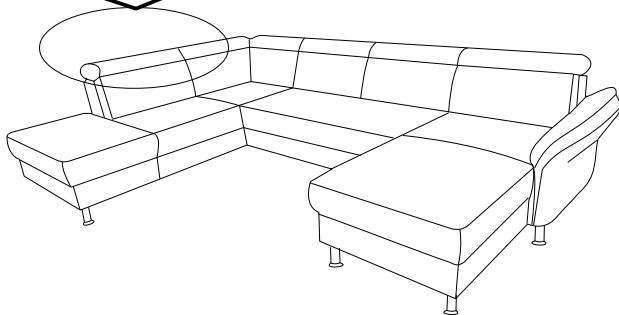
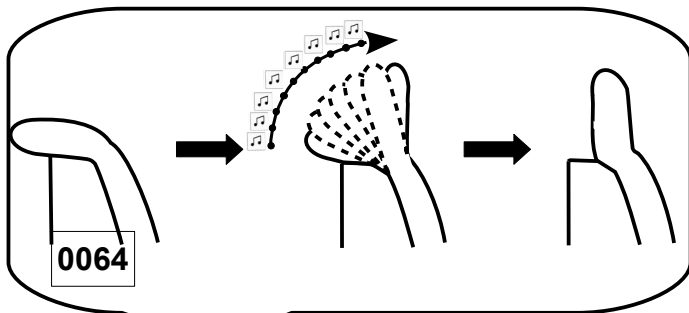

0237

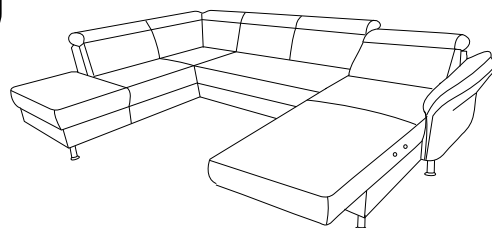

L

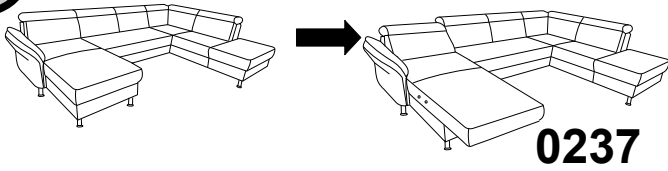

R

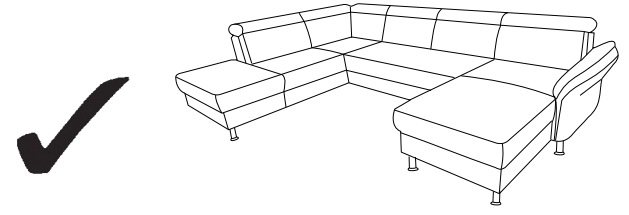
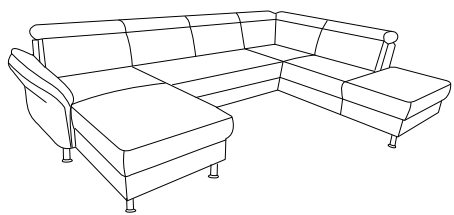
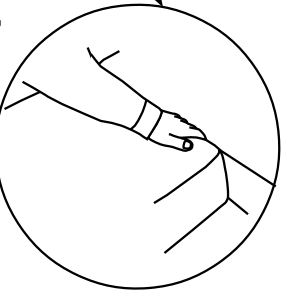
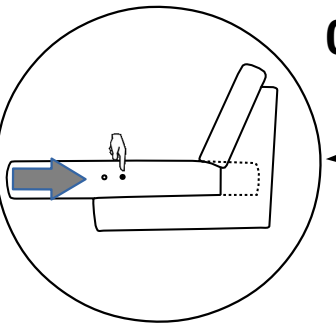
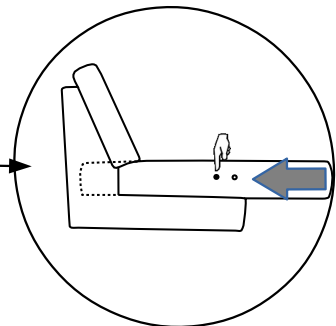
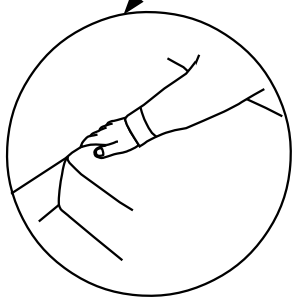
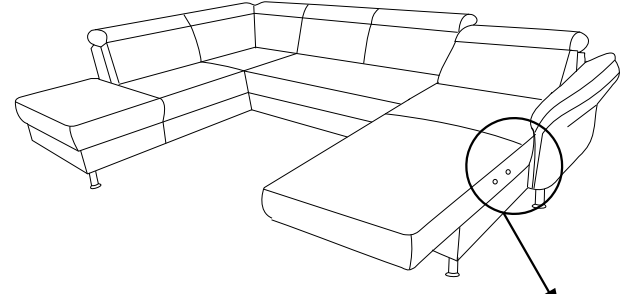
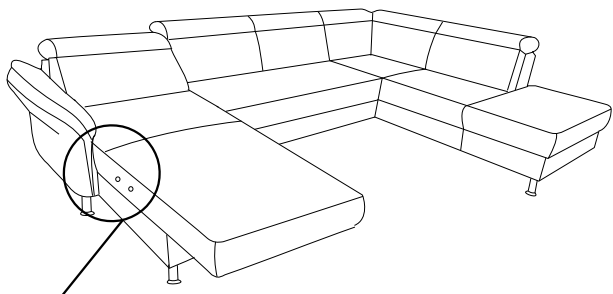
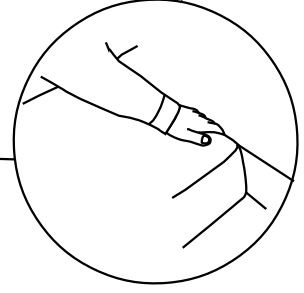
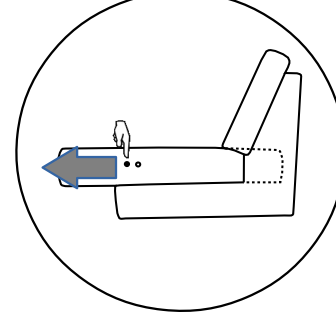
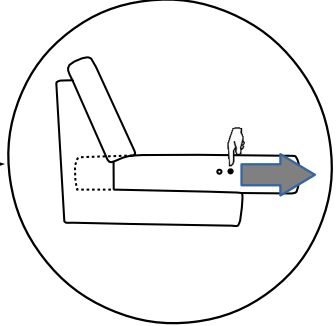
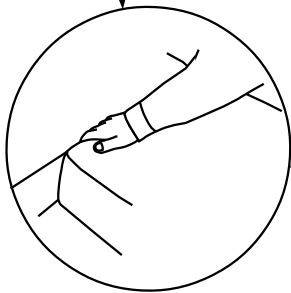
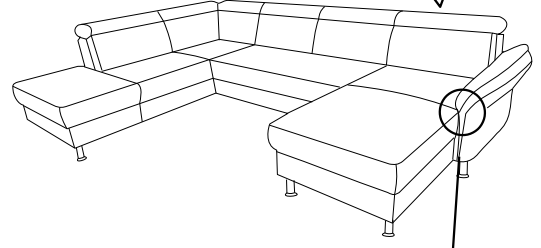
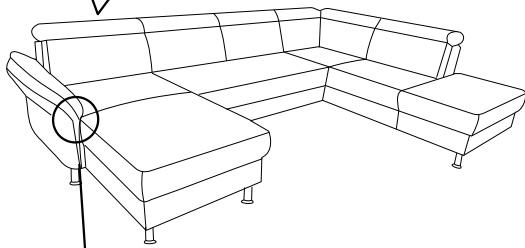
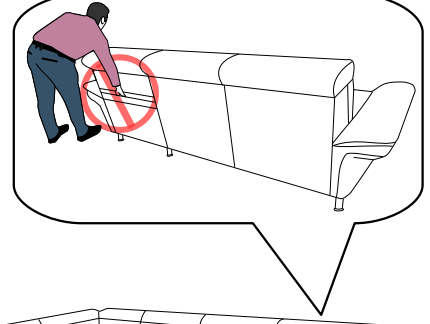
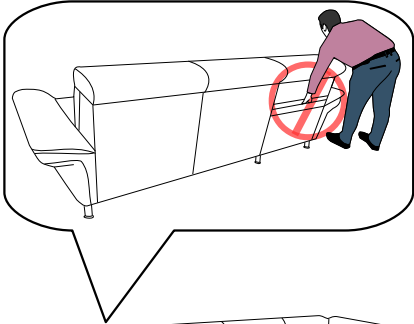
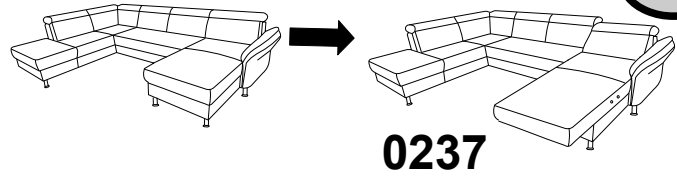

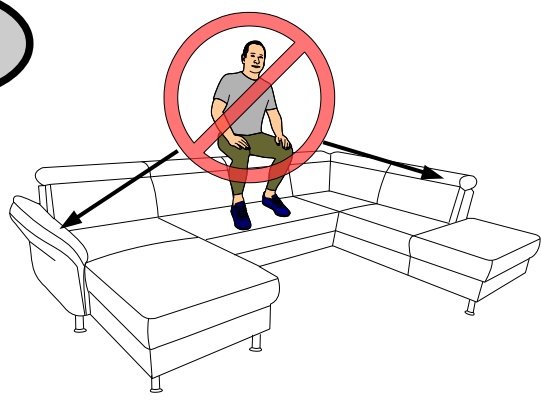

0237

L



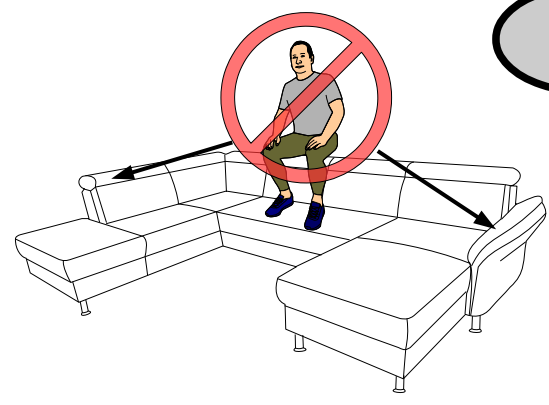

R

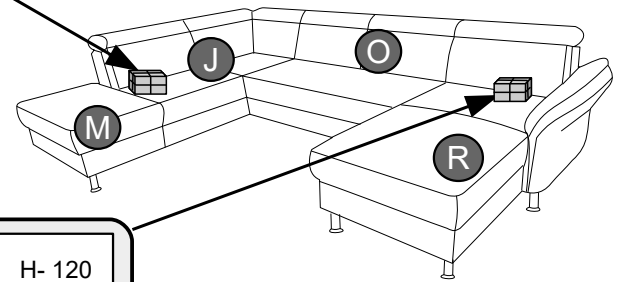
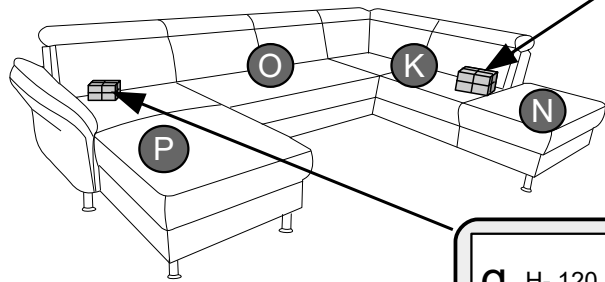

g H- 120  X3	s H- 120 [mm]  X4
--	---



g H- 120  X1	s H- 120  X5
--	--

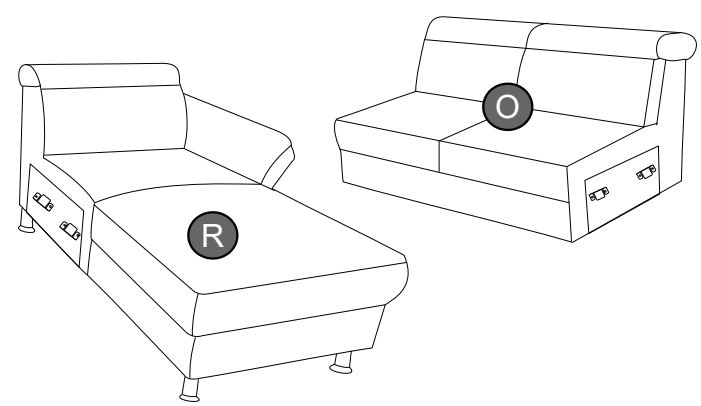
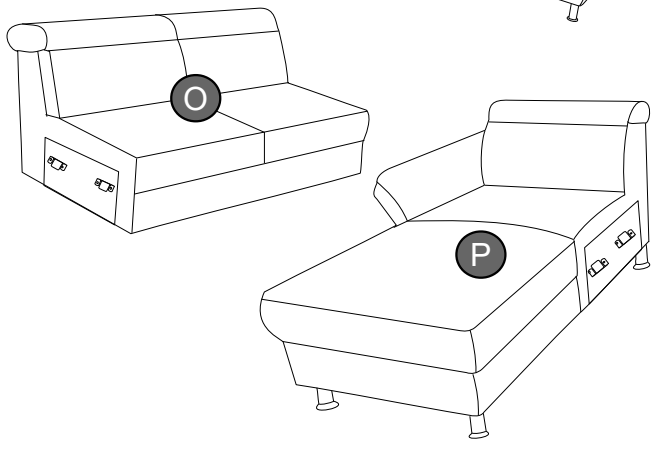
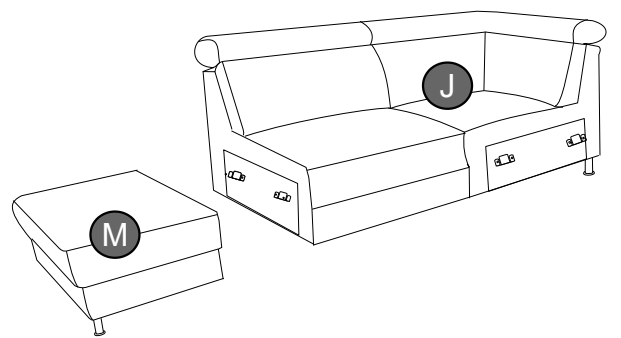
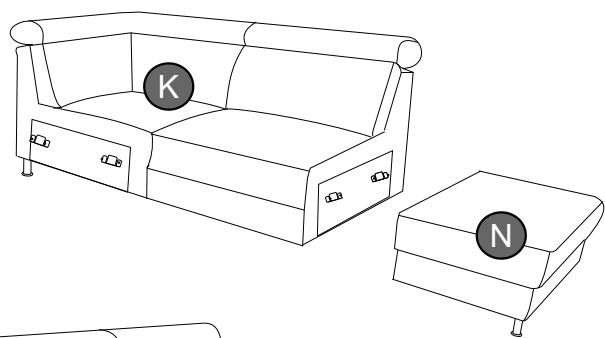

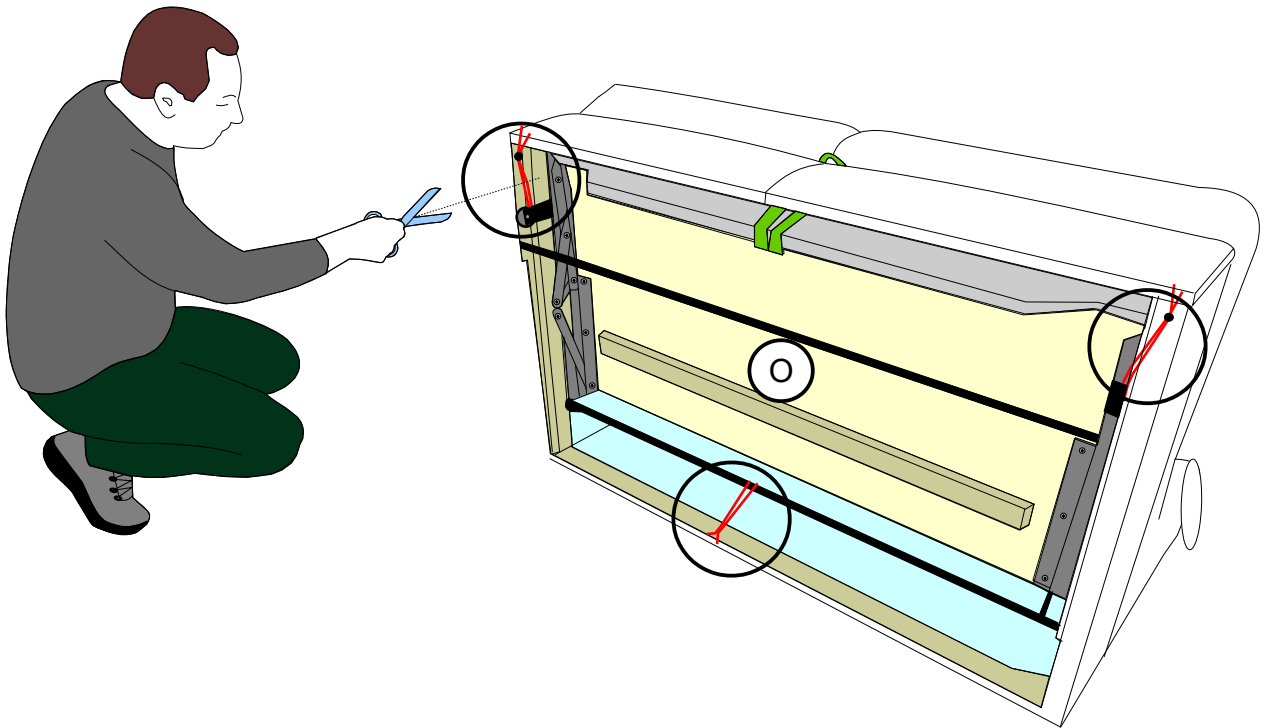
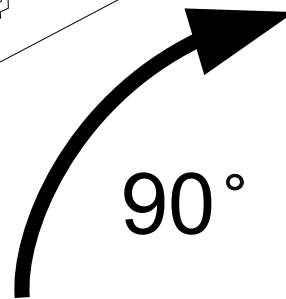
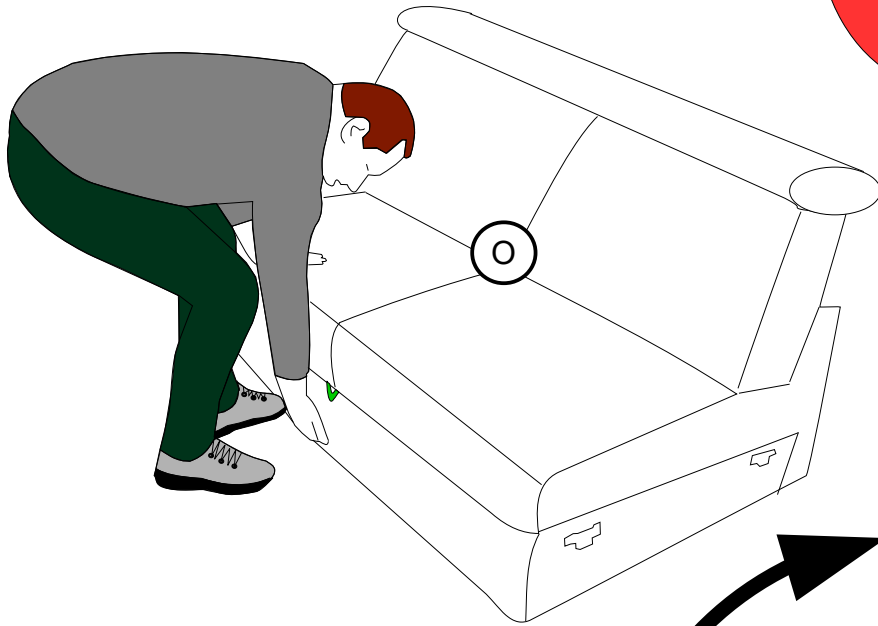

0019

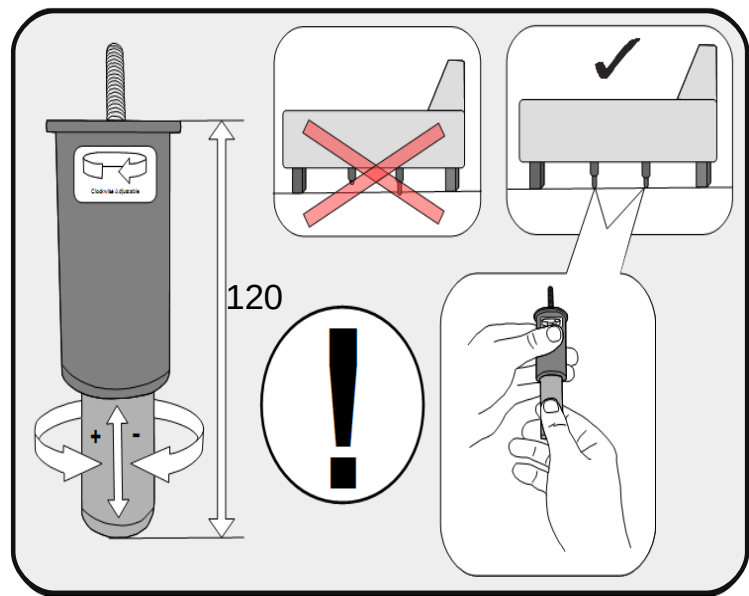
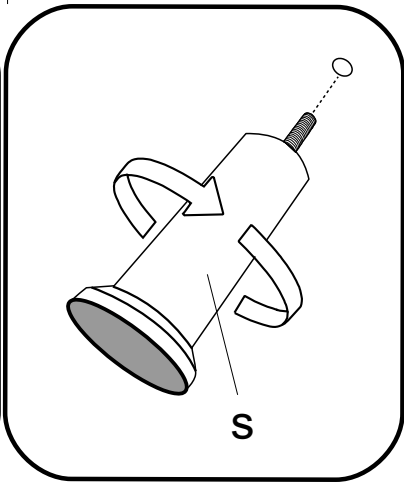
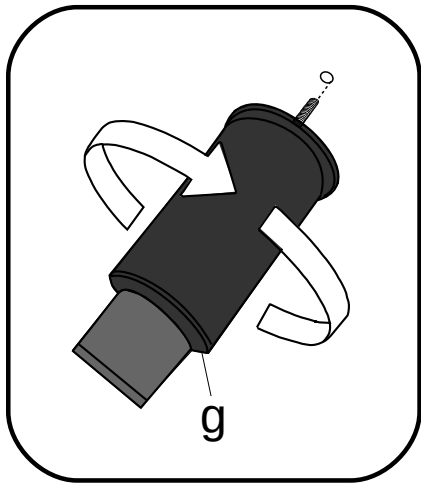
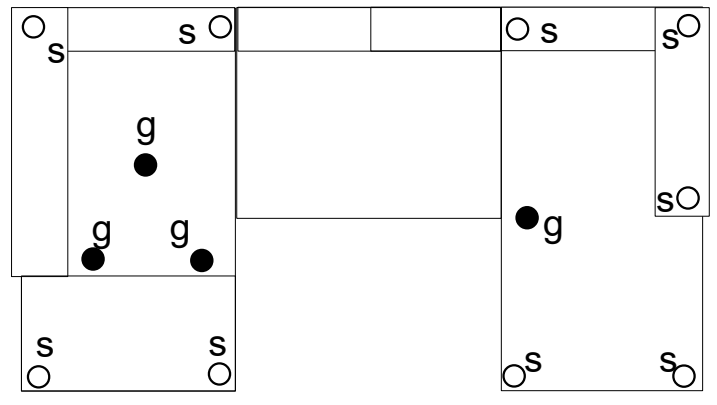
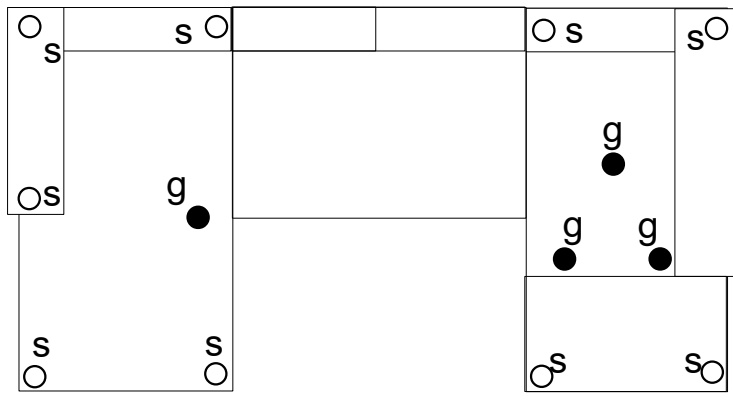
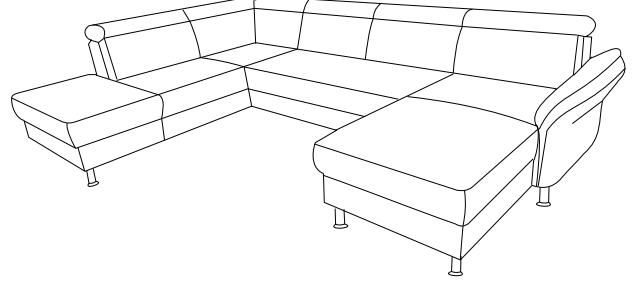
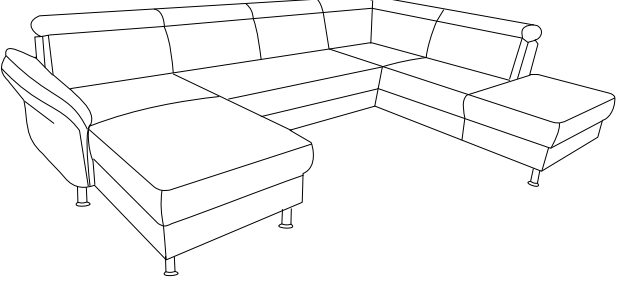
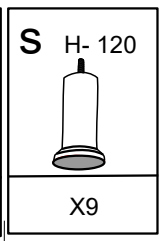
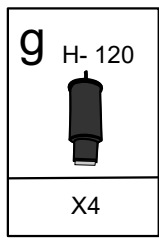

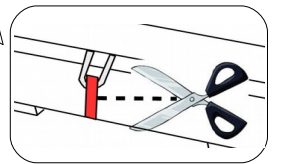
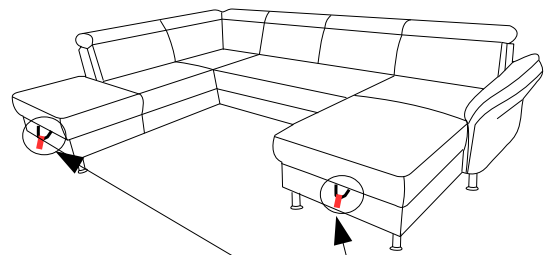
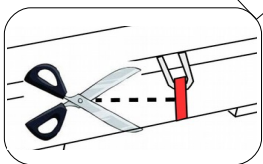
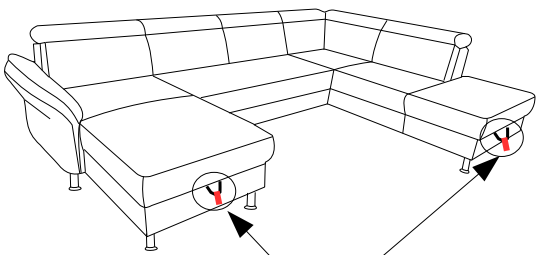
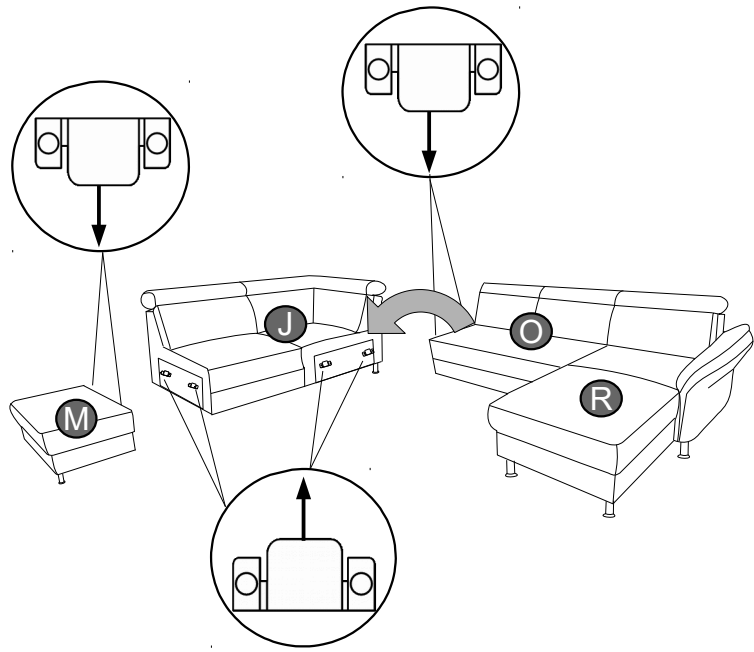
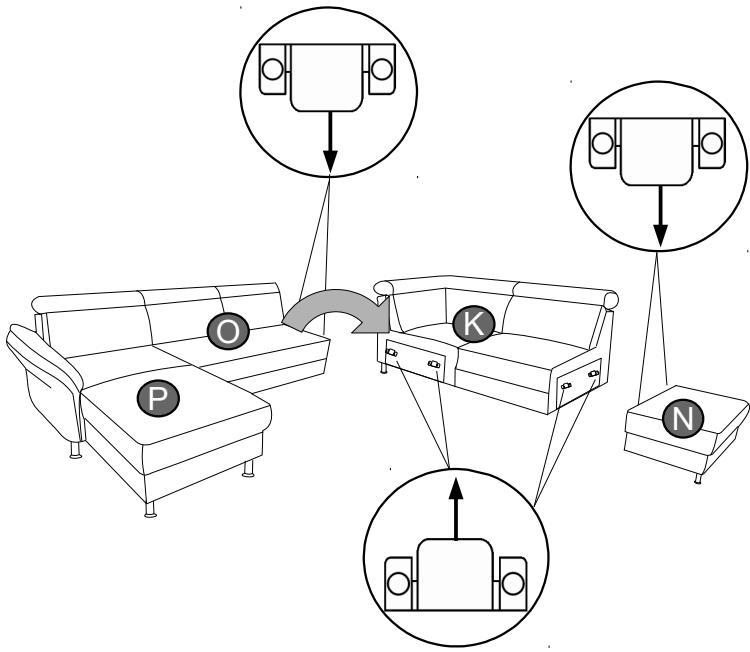
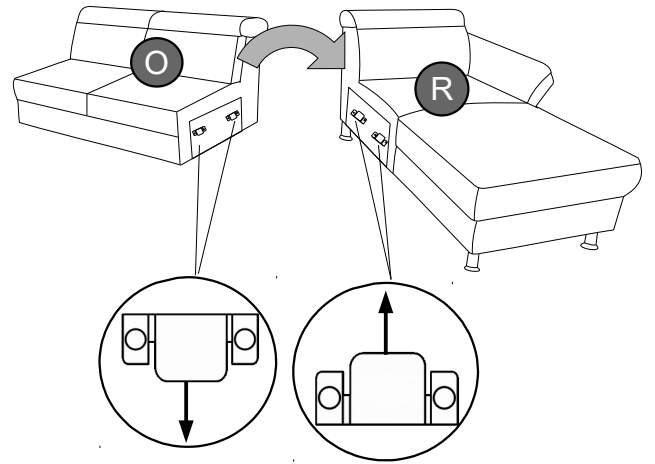
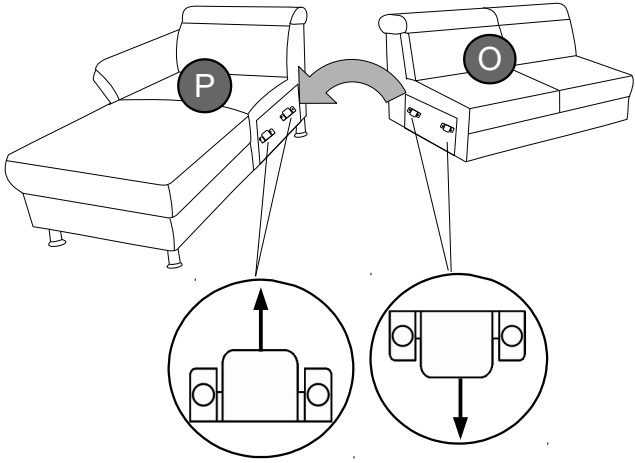
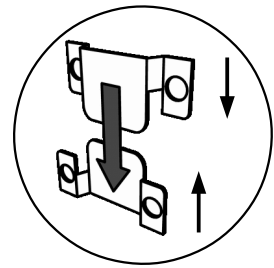
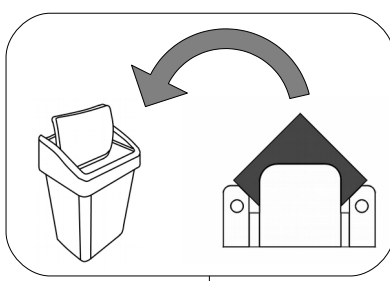
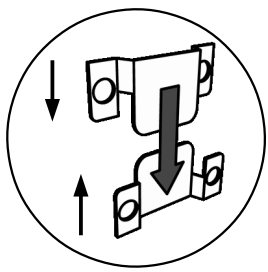

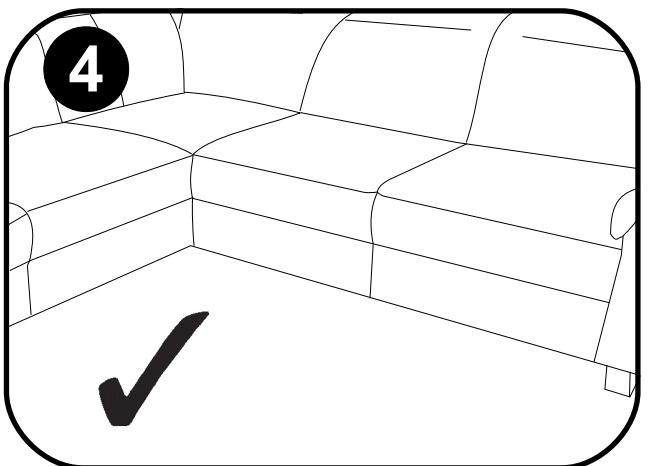
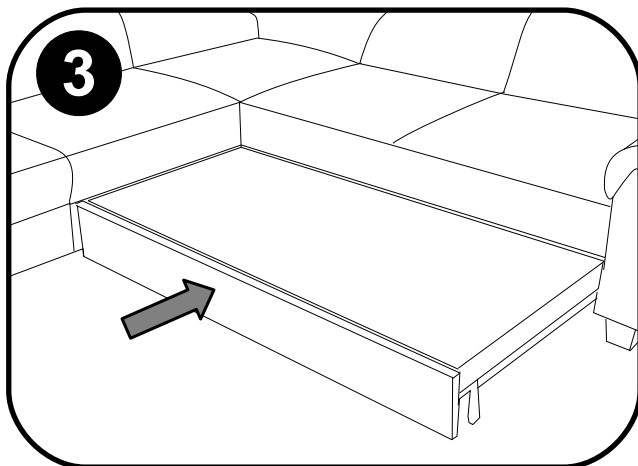
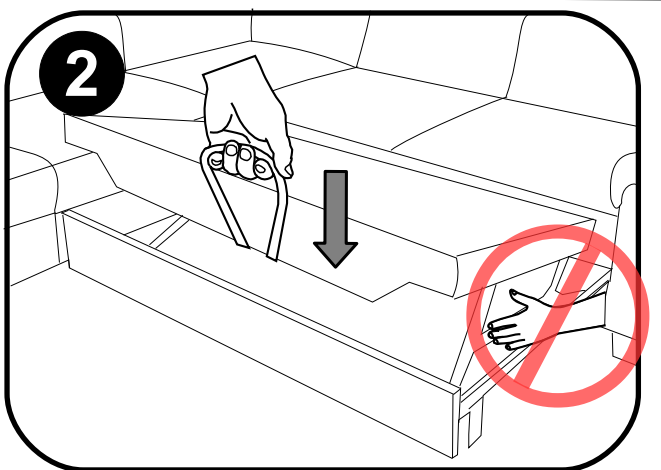
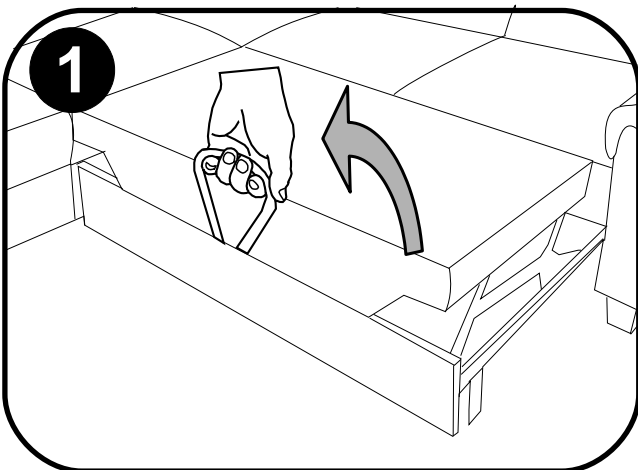
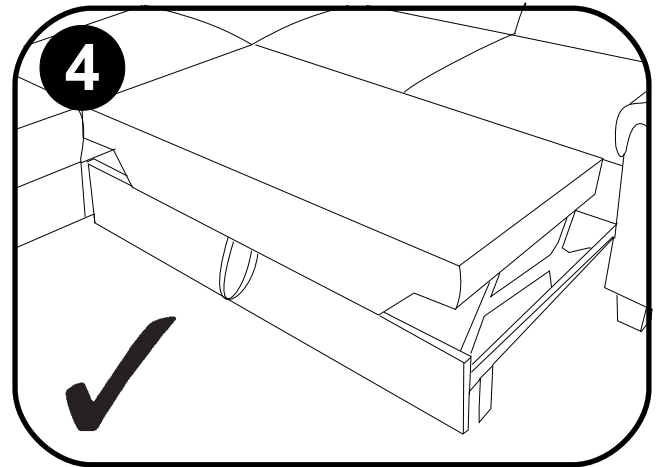
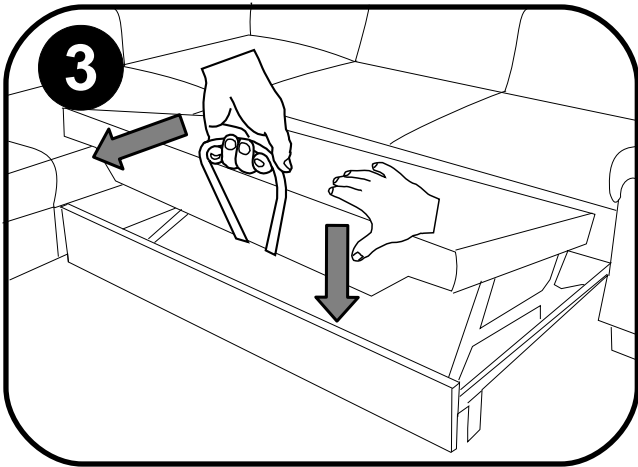
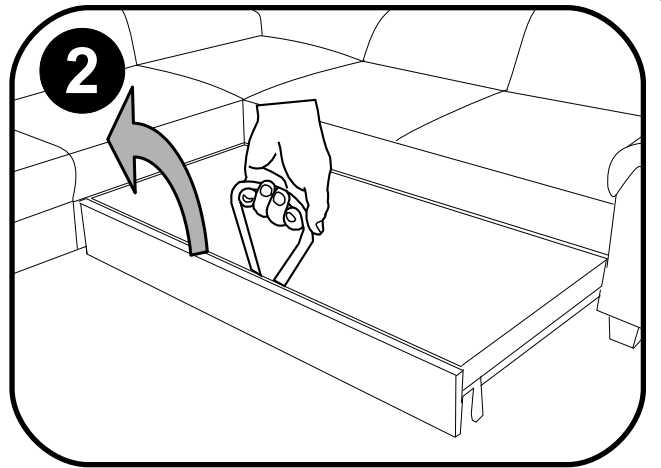
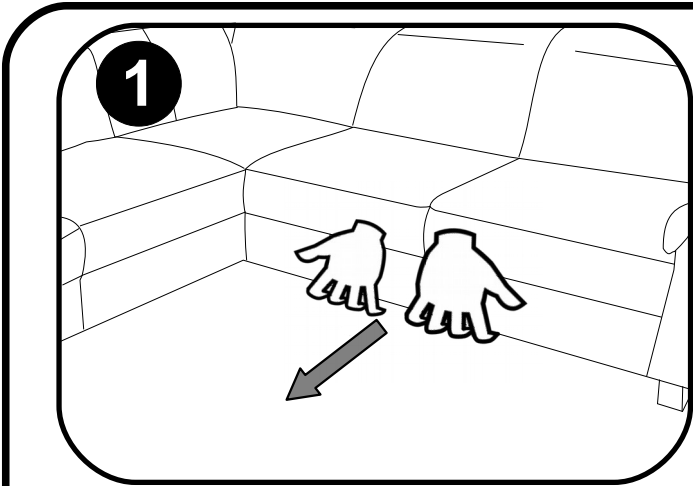
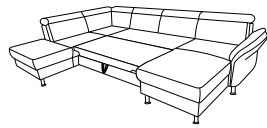
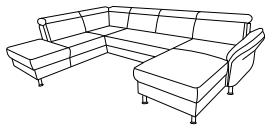

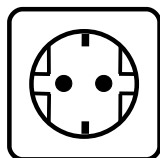
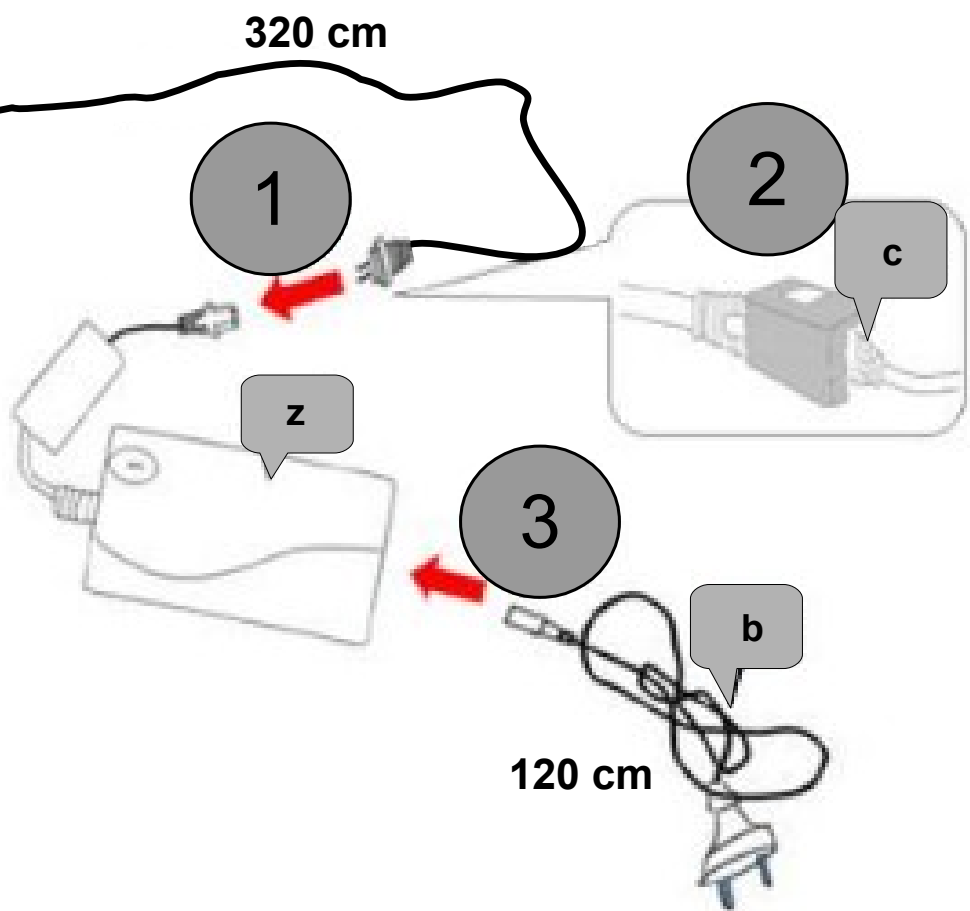
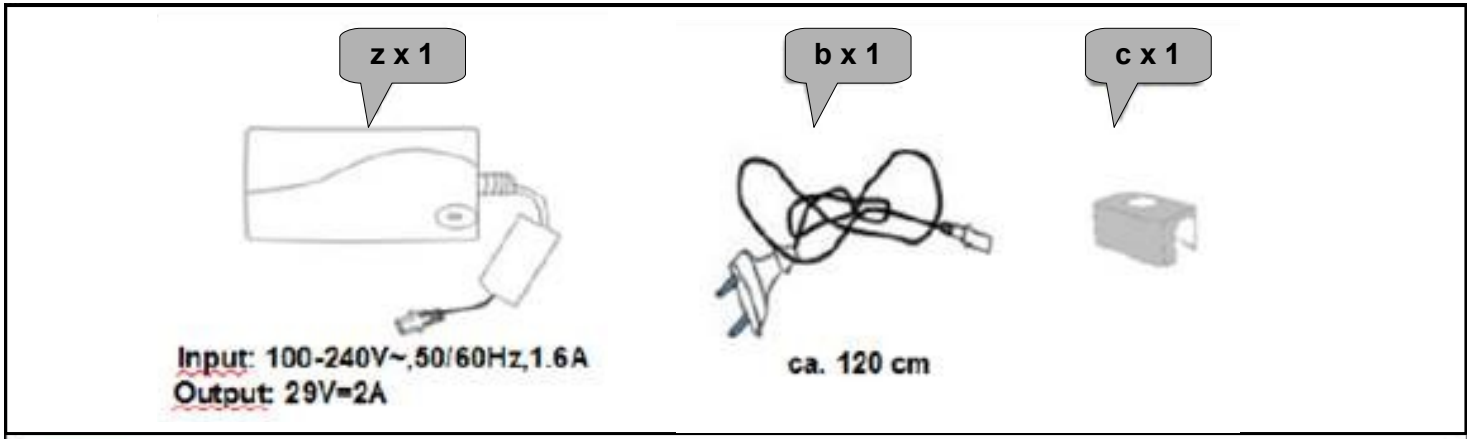

220 V 50 HZ - EU

Service · Dienstverlening · Serwis · Servis · Сервисная служба · Serviciu · Services · Servizio
 · Servisný list · Szolgáltatás · Servisní list

Name · Naam · Nazwa · İsim · Название · Nume · Nome · Názov · Názov ·
 Název · Neve

CALYPSO V

Typ · Type · Tip · Тип · Tipo · Típus

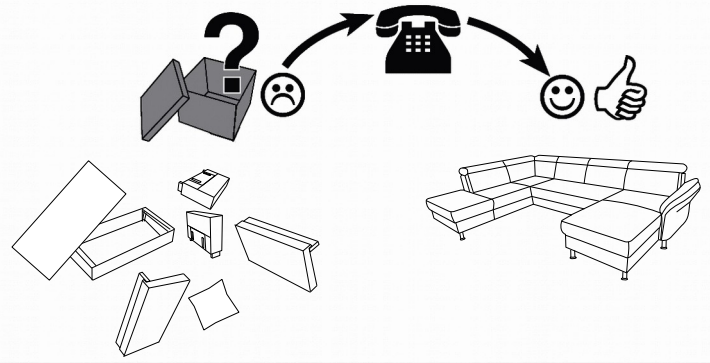
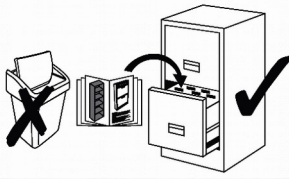

L

R

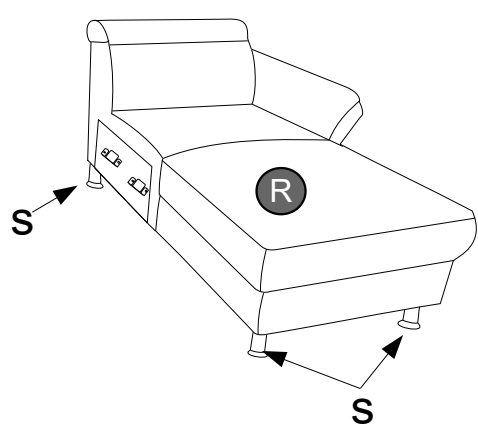
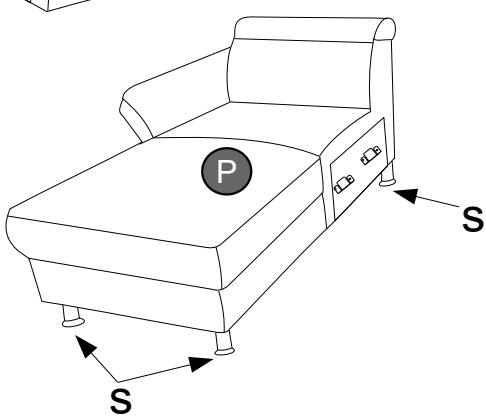
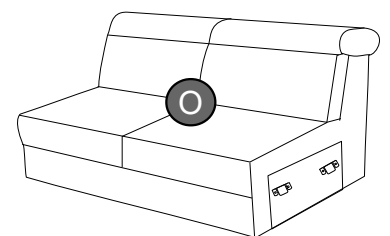
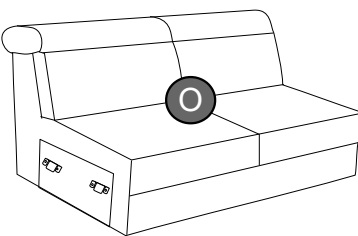
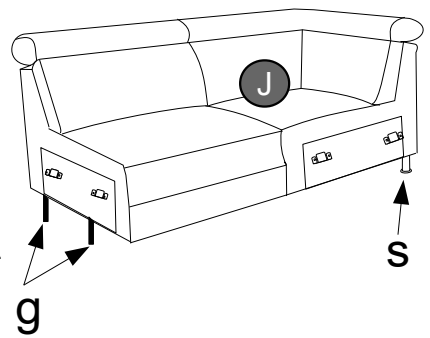
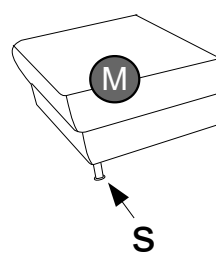
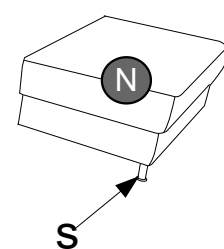
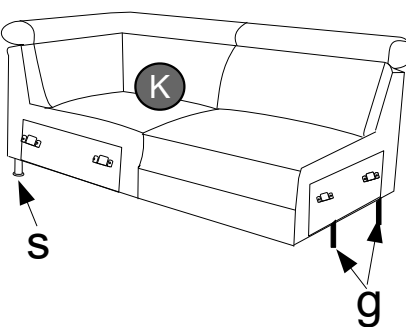
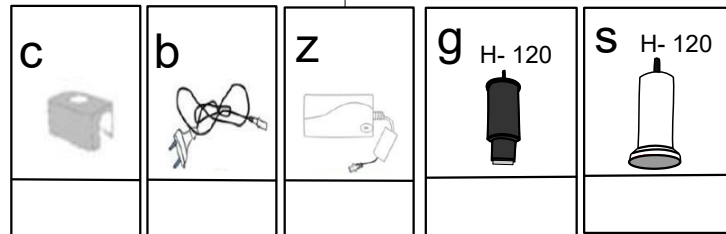
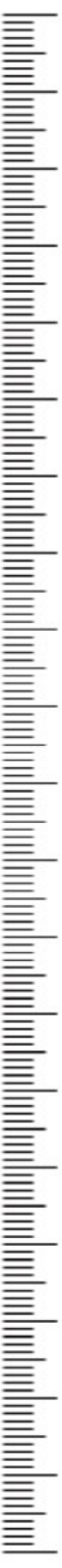
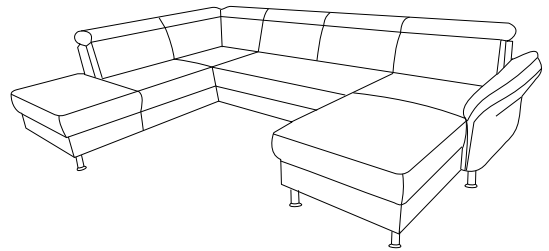
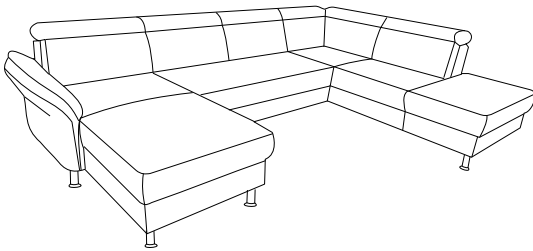

EU- KONFORMITÄTSERKLÄRUNG DECLARATION OF CONFORMITY

Erzeugnis Product	Polstermöbel mit elektrischen Relaxfunktionen
Typenbezeichnung Model/Type	8141, 8142, 8143, 8144
Funktion/ Function	092, 0237

Die alleinige Verantwortung für die Ausstellung dieser Konformitätserklärung trägt der Hersteller:
This declaration of conformity is issued under the sole responsibility of the manufacturer:

Hersteller (Firma und Ort) **Steinpole Central Services Sp. z o.o.**
 Manufacturer (Name and place) ul. Fabryczna 13; PL-69-110 Rzepin

Der oben beschriebene Gegenstand der Erklärung erfüllt die einschlägigen Harmonisierungsrechtsvorschriften der Gemeinschaft:

The object of the declaration described above is in conformity with the relevant Union harmonisation legislation:

2006/42/EG	Maschinenrichtlinie	Machinery Directive
2012/19/EU	WEEE-Richtlinie	WEEE Directive
2014/30/EU	EMV-Richtlinie	EMC Directive
1907/2006/EC	REACH	REACH
2014/35/EU	Niederspannungsrichtlinie	LVD Directive
2001/95/EC	Sicherheits-Richtlinie	Safety Directive
2011/65/EU&2015/863/EU	RoHS Richtlinie 2/3	RoHS Directive
2019/1021/EU	EU-POP	EU-POP
2009/125/EG:2009	ErP Richtlinie	ErP Directive
2013/35/EU	EMF Richtlinie	EMC Directive

Es wird die Übereinstimmung mit weiteren, ebenfalls für das Produkt geltenden harmonisierten Normen oder normativen Bestimmungen erklärt:

The following harmonised standards and normative documents are those to which the product's conformance is declared:

EN 60335-1:2012+A11:2014+A13:2017+A1:2019+A14:2019+A2:2019+A15:2021		DIN EN 1725:1998-02
EN 60335-2-29:2004+A2:2010+A11:2018		EN 61000-3-2:2014
EN 55014-1:2017/A11:2020	EN 55014-2:1997+A1:2001+A2:2008	EN IEC 63000:2018
EN 61000-3-3:2013	EN 62233:2008	EN 62368-1:2014+A11:2017
EN 50564:2011	EN 61204-3:2000	DIN EN 12520:2016-03
DIN EN 50563:2014-09	EG.Regulation 1275/2008+801/2012+2019/2021	DIN EN 1728:2014-02
DIN EN 13759:2012-06	EN 1022 - 2019-04	EN 62321-3-1:2014
EN 62321-1:2013	EN 62321-2:2014	EN 62321-6:2015
EN 62321-4:2014+A1:2017	EN 62321-5:2014	EN 62321-8:2017
EN 62321-7-1:2015	EN 62321-7-2:2017	
IEC 60335-2-116:2019		

Rzepin, 27.01.2023

 Jürgen Mußmann
 Geschäftsführer

 Uwe Gräfe
 Prokurent

DE

Bitte achten sie darauf, dass Ihre Kinder nicht mit Mechanik dieses Möbelstückes spielen.
Halten Sie Hände und Füße von der Mechanik fern, das Fußteil senkt sich beim Schließen.
Verlassen Sie da Möbel immer in einer aufrechten, geschlossenen Position.
Die Funktion sollte nur vom Nutzer des Möbelstückes bedient werden.

PL

Proszę uważać, aby Państwa dzieci nie bawiły się mechanizmem mebla.
Oddalić nogi i ręce od mechanizmu, część nóżki opuszcza się przy zamknięciu.
Pozostawić mebel zawsze we właściwej i zamkniętej pozycji.
Funkcja powinna być obsługiwana tylko przez użytkownika mebla.

GB

Do not allow children to play on this mechanized furniture or operate the mechanism.
Legrest folds down on closing so that a child could possibly be injured.
Always leave in an upright and closed position.
Keep hand and feet clear of mechanism. Only the occupant should operate it.

CZ

Dávejte pozor, aby vaše děti nehrají s mechanismem nábytku.
Chraňte před nohou a rukou mechaniky, část nohy listky na zavření.
Ponechte kus nábytku je vždy v právu a uzavřenou polohou.
Funkce by měla být podporována pouze uživatelem nábytku.

SK

Dávajte pozor, aby vaše deti nehrajú s mechaniky nábytku.
Chrňte pred nôh a rúk mechaniky, časť nohy listky na zatvorenie.
Ponechajte kus nábytku je vždy v práve a uzavretou polohou.
Funkcia by mala byť podporovaná len užívateľom nábytku.

RO

Legyen óvatos, hogy a gyermekek ne játsszanak a mechanika a bútörök.
Tartsa távol kezeit és lábait a mechanika, a láb egy részét elhagyja a zárás napján.
Hagyja a bútordarab mindig a jobb és egy zárt helyzet.
A funkció támogatni kell csak a felhasználó a bútörök.

HU

Fii atent că copiii dumneavoastră nu se joacă cu mecanica de mobilier.
Ține departe de picioare și mâini ale mecanicii, parte a piciorului pleacă la închidere.
Lasă piesa de mobilier este întotdeauna în dreapta și o poziție închisă.
Funcția trebuie să fie susținută numai de către utilizatorul de mobilier.

IT

Non permettere ai bambini di giocare o azionare il meccanismo.
Chiudendolo le gambe restano piegate e quindi un bambino può ferirsi.
Lasciare sempre il meccanismo in posizione verticale e chiuso.
Tenere mani e piedi lontano dal meccanismo.
Solo l'occupante può azionarlo.

FR

Faites attention s'il vous plaît, pour que vos enfants ne jouent pas à la mécanique du meuble.
Éloigner les jambes et les mains de la mécanique, une partie de la jambette s'abaisse pendant la fermeture.
Laisser le meuble toujours dans une position propre et fermée.
La fonction devrait être utilisé uniquement par l'utilisateur du meuble.

TR

Çocukların bu mobilya mekanizması ile oynaması veya kullanması yasaktır. Bacak dinlendirme fonksiyonu aşağı katlandığı için çocuklar yaralanabilir. Her zaman dik ve kapalı konumda bırakmalıdır. El ve ayaklar mekanizmadan uzak tutulmalıdır. Sadece oturan kişi kullanılmalıdır.

RU

Будьте осторожны, что ваши дети не играли с механизмом мебели.
Хранить вдали от рук и ног от механизма, часть ноги оставляет при закрытии.
Оставьте мебель всегда в праве и закрытом положении.
Функция должна поддерживаться только пользователем мебели.

NL

Laat kinderen niet op dit mechanische meubel spelen of het mechanisme in werking zetten.
De benen steun vouwt naar beneden zodat een kind mogelijk verwond kan raken.
Laat de benen steun in een rechte en gesloten stand.
Houd handen en voeten weg van het mechanisme.
Enkel diegene die in de zetel zit, mag het mechanisme in werking zetten/bedienen.