



**Gas Cooker with Grill  
for Outdoor use  
INSTRUCTION MANUAL  
Model: G-87/G-87C**

---

The designs in the figures are purely indicative. The manufacturer also reserves the right to make any modifications to the products as many be considered necessary or useful.

---

ENGLISH

Read instructions carefully before installation and use!

Thank you for choosing our gas cooker. Please read these instructions carefully before use and keep them for future reference on how to use.

The designs in the figures are purely indicative. The manufacturer also reserves the right to make any modifications to the products as many be considered necessary or useful.

**Alert!** Persons with reduced physical, sensory, mental capabilities or lack of experience and knowledge, should not use the device. They must be supervised or be instructed to work with the appliance by a person responsible for their safety. Do not allow unsupervised children to use the appliance.

## FEATURES

- High quality auto-ignition, catching fire 100%
- Using life for ten years or more.
- The whole meticulous curl make the stove body more smooth.
- Patent trivet, convenient and applicable.
- Double burner has small inner and large outer burner rings.
- Patent design burner, efficiency combustion, strong flame, less gas.

## NAME OF PARTS

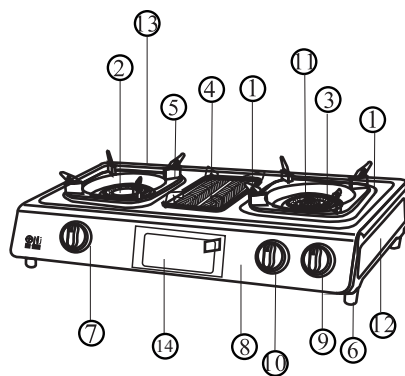

1

1. Top panel
2. Burner
3. Double burner
4. Grill
5. Trivet
6. Rubber legs
7. Gas control knob
8. Front panel
9. Gas control knob and burner selection
10. Gas control knob for the grill
11. Brass cap
12. Side panel
13. Back panel
14. Grill door

## CAUTION & WARNING

- Do not use a gas other than that which is specified on the label attached (Fig. 1).
- Gas category I 3B/P**
- Use for cooking only. Do not use dry towels, clothes, etc., over it (Fig. 2).
- To avoid damage, do not place charcoal on the burner.
- Avoid covering the flame with a big plate which covers the gas cooker.
- Do not use the gas cooker where the flame may be blown off by the wind.
- Make sure that there are no inflammables near the gas cooker (Fig. 3).
- Use only a rubber hose, do not use a vinyl plastic hose, as this can be dangerous (Fig. 4).
- While it is in use check from time to time, whether it burns normally.
- After use, turn the ignition knob back to OFF position and make sure the burner is put out (Fig. 5).
- When going to bed or leaving the house, be sure to turn off not only the ignition knob but also the main gas valve as well.
- The main gas valve not in use should be closed and covered by the cap.

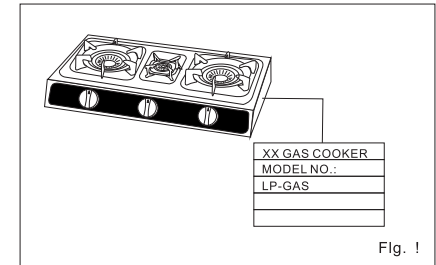

Fig. 1

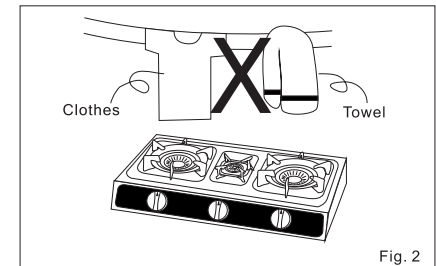

Fig. 2

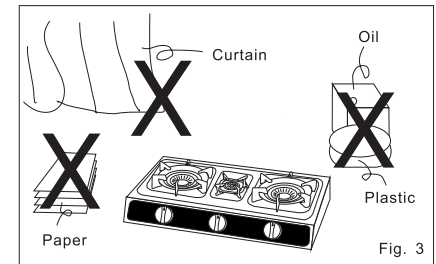

Fig. 3

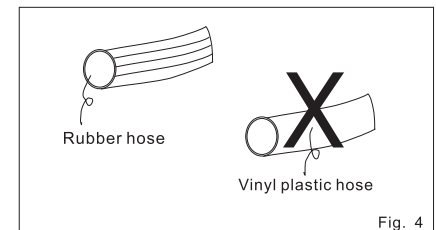

Fig. 4

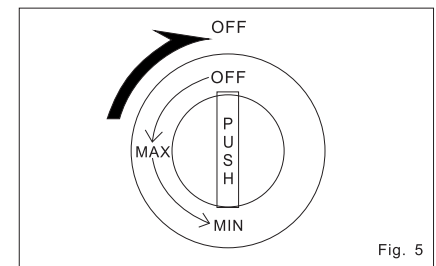

Fig. 5

2

- Be careful to avoid getting burned by touching the top panel of the gas cooker, as it gets very hot near the burners when in use.

- Make sure the room is well ventilated. Never use the gas cooker for long periods of time (over 10 minutes) in a small room or in a closed-off space without the ventilation, by the ventilation fan or opening the windows (Fig. 6).

- If a gas leak is found, close the main gas valve, open up all windows, and call your dealer. Do refrain from turning an electric switch on or off, lighting a match, or using a lighter (Fig. 7).

- The gas cylinder should stand away at least 0.5m from the cooker (Fig. 8).

- Knob is designed for anti-clockwise ignition, so that to prevent children act.

- In the event of a burn back (i.e. where the gas burns back on the jet), turn off the valve and light again. Should the problem persist take the unit back to your dealer for checking.

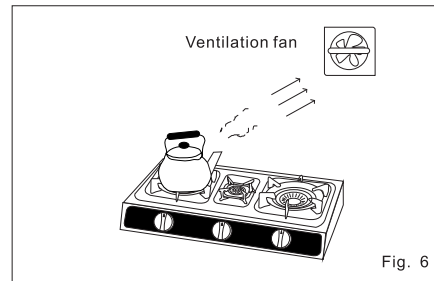

Fig. 6

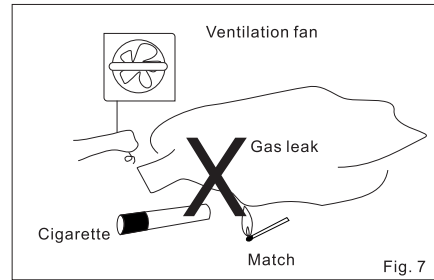

Fig. 7

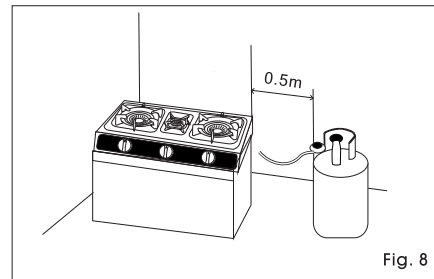

Fig. 8

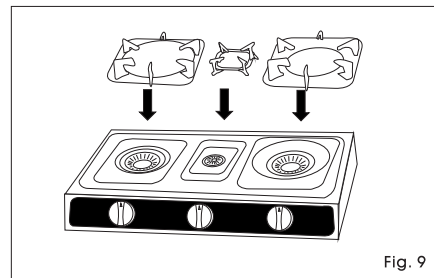

Fig. 9

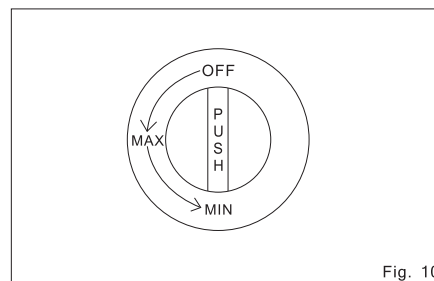

Fig. 10

## BEFORE USE

- Confirm that you have the right model for your type of gas supply.

- When unpacking, make sure that all of the parts of the gas cooker are included. Assemble the parts as shown in (Fig. 9).

- Place the gas control knob onto the gas cock axis and push it inwards firmly (Fig. 10,11).

- Attach the rubber legs to the cooker by turning the cooker upside down and screwing them into the openings on the cooker bottom (Fig. 12).

- Install the burners.

- Place the trivets on top of the burner.

The trivets can be adjusted by turning the screws and then the pan can be put on the trivets steadily.

- Push the rubber hose onto the hose joint as far as it will go. Do not use vinyl plastic hose, as this can be dangerous. Secure the hose (Fig. 13) see to it that the rubber hoses does not touch a part of the gas cooker nor lies underneath it.

- When choosing a place to put the gas cooker, be sure to pick a spot that is firm and level. The gas cooker need plenty of space and air. Allow at least 15cm of space on the sides and 100cm above the unit (Fig. 14). If the space is less than 15cm from the in-flammable walls, be sure to provide a heat insulation board. Also be sure to keep paper, oil and all other inflammable objects away from the gas cooker.

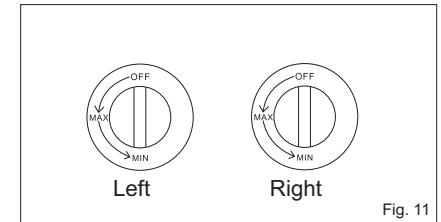

Fig. 11

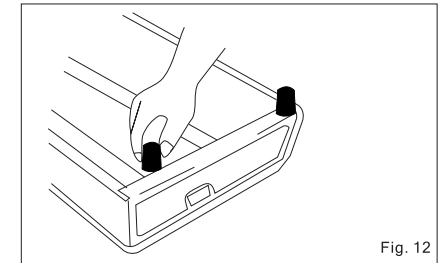

Fig. 12

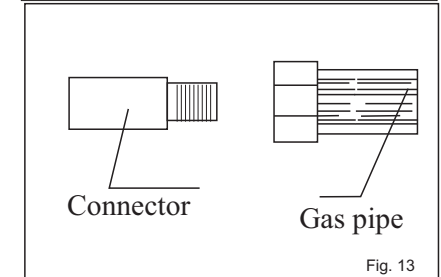

Fig. 13

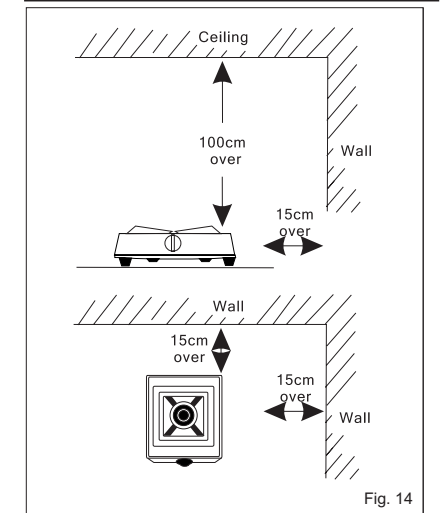

Fig. 14

## How to use

### 1. TO LIGHT THE BURNERS

A. Open the main gas valve. Push the gas control knob in and turn it towards the MAX position (counter-clockwise) until you hear the ignition click. Make sure that the burner has been lit (Fig. 15). In this position, double burner will light up both the small and large burners. To use only the small burner, release the gas control knob and turn it further to the MIN position (Fig. 16).

B. To adjust the flame size, set the gas control knob to a suitable position between MAX (full flame size) and MIN position (small flame size).

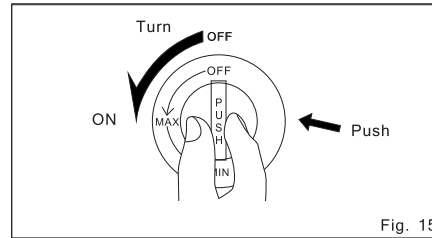

Fig. 15

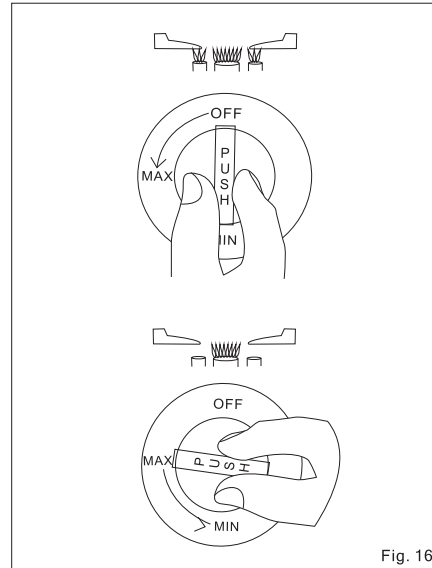

Fig. 16

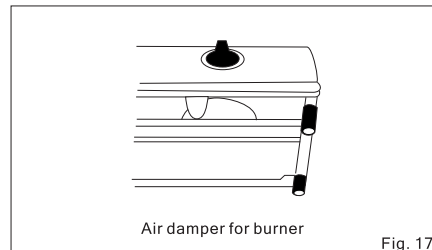

Fig. 17

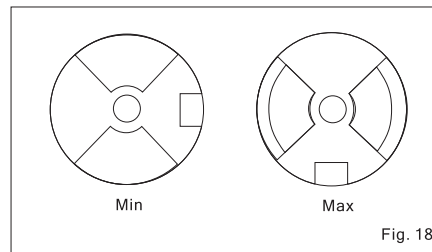

Fig. 18

### 2. Air flow adjustment:

The burners usually need no air flow adjustment.

If they should ever burn improperly, the air flow can be controlled by adjusting the air damper inside the gas cooker (under the control knob).

After the gas has been ignited, adjust the air damper until slightly rounded, vigorous blue flames appear (Fig. 17,18,19).

### 3. If the burner do not ignite at the same time:

This may be the result of air in the gas hose. Turn the gas control knob back to OFF and try again until the burner ignite.

### 4. To turn the burners off:

Turn the gas control knobs back to OFF position until you hear a click. Make sure the burner is put out and turn off the main gas valve as well.

**ATTENTION: Use only low pressure regulator valve.**

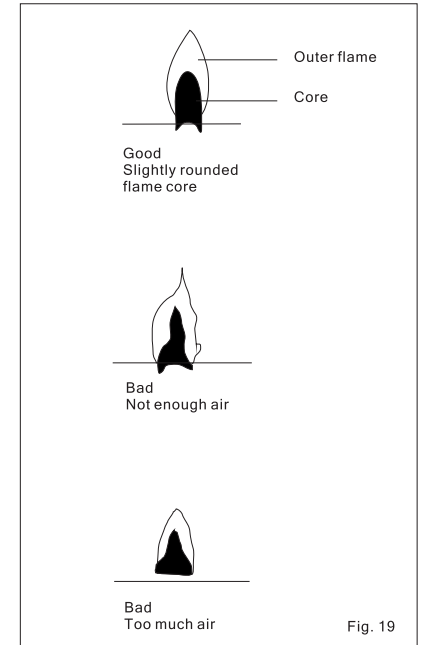
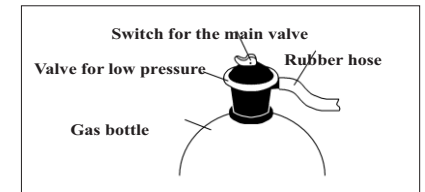

Fig. 19



## Providing fire safety

1. Do not move the gas cooker while it is in use.
2. After use stop the gas supply at the gas cylinder from the gas valve.
3. If there is a gas leak, or if there is a scent of gas, close immediately the gas valve. Do not use appliances which can cause a spark.

**WARNING:** Do not use the gas cooker without the trivets, directly on the burners. Do not change the gas cooker's construction.

## CARE AND MAINTANCE

Before you check and care for your gas cooker, make sure to turn off the main gas valve and wait for a period to check that the flame at the burners is down. Check the gas hose regularly for wear of leaks. It must be replaced occasionally.

Keep it away from heater sources and keep it clean. Wipe the stainless steel top and body with dry cloth. If it is difficult to clean use soapy water and dry thoroughly with a dry cloth.

Wash the trivet in water and dry thoroughly before replacing.

The electronic ignition will not unction if it is wet (Fig. 20).

For better service and longer service life, keep the gas cooker clean.

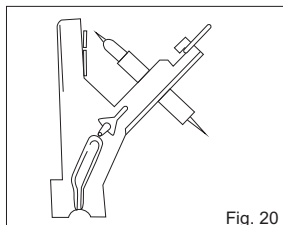

## TROUBLE-SHOOTING GUIDE

Trouble	Cause	Remedy
It does not ignite	<ul style="list-style-type: none"> <li>- Main gas valve remains closed</li> <li>- The rubber hose is bent</li> <li>- No gas supply</li> <li>- Electronic ignition is wet</li> </ul>	<ul style="list-style-type: none"> <li>- Open it</li> <li>- Put it right or replace it</li> <li>- Replace the gas cylinder</li> <li>- Clean and dry it</li> </ul>
If smell of gas	<ul style="list-style-type: none"> <li>- Gas leak from hose</li> <li>- Rubber hose is damaged</li> <li>- Burner is not lit</li> </ul>	<ul style="list-style-type: none"> <li>- Examine hose using soap water and replace it</li> <li>- Replace it</li> <li>- Re-ignite it</li> </ul>

Combustion is Abnormal	<ul style="list-style-type: none"> <li>- Lack of gas supply</li> <li>- Flame ports are clogged</li> <li>- Burner is not in its correct position</li> </ul>	<ul style="list-style-type: none"> <li>- Replace gas cylinder</li> <li>- Clean them</li> <li>- Place it to a right position on a firm none flammable surface</li> </ul>
Burning is with a yellow flame	<ul style="list-style-type: none"> <li>- Improper adjustment of the air valve</li> </ul>	<ul style="list-style-type: none"> <li>- Turn the air valve of the nozzle to the left or right until the flame became blue</li> </ul>

## SPECIFICATIONS

**Warning!** This appliance shall be installed in accordance with the regulations in force and used only outdoor. Read the instructions before installing or using this appliance.

Product	Gas stove with grill		
Model	G-87		
Gas type	LPG		
Gas category	I3+ (28-30/37)	I3B/P (30)	I3B/P (50)
Rated pressure	Butane : 28-30 mbar Propane: 37 mbar	Propane - Butane: 30 mbar	Propane-Butane: 50 mbar
Country	GR,GB	BG, RO	DE, AT
Heat input (kW)	R 4,1 / M 2,2 / L 3,4	R 4,1 / M 2,2 / L 3,4	R 4,1 / M 2,2 / L 3,4
Gas rated (g/h)	R 297 / M 52 / L 252	R 302 / M 180 / L 256	R 302 / M 180 / L 256
Safety device	No		
Hose	Ø 9,5 mm rubber hose, max. length 1,5 m		



### DISPOSAL

Please consider our environment

Separate the packaging materials for disposal as required by your local waste disposal regulations. Cardboard and paper belong in the waste paper collection, plastic in the recycling collection.

When you wish to dispose of the appliance, remove the cable and dispose it in an environmentally friendly way (e.g. recycling plant).

## AFTER SALE SERVICE

When you find something wrong with your gas cooker, make checkups by referring to the "Trouble-Shooting guide". If you can't find out the cause of the trouble from such, get into contact with your dealer.