

ASSEMBLY INSTRUCTION

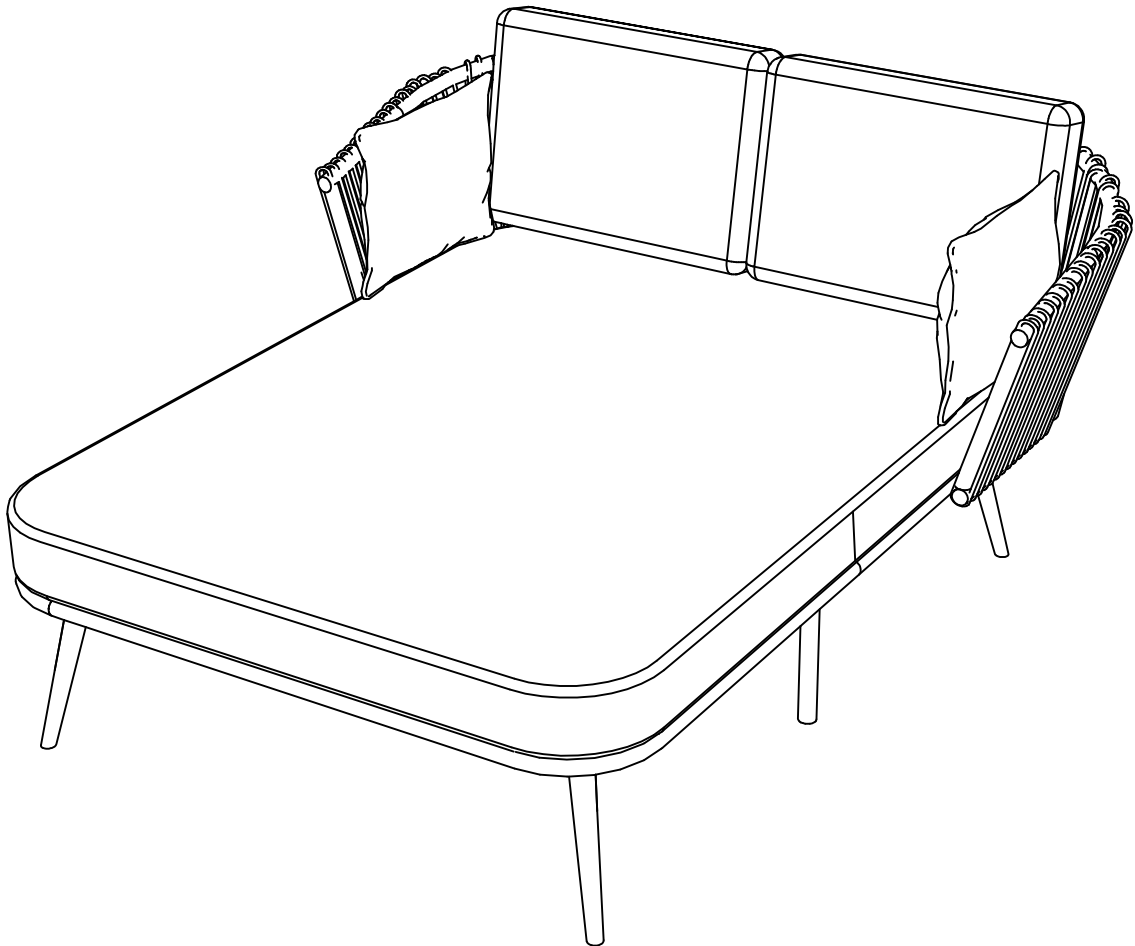

WF317141 WF317142

Notice:

1. 50% Tighten before fixing all screws, Allen wrench is recommended instead of an electric drill.
2. Place the item on a flat ground to adjust and make sure it remains stable
3. Tighten up all screws with tools gradually.
4. If the screws are not aligned with holes during assembly, please loosen all the other screws to 50% and continue the assembly process.
5. If the item is not stable, please loosen all the screws, adjust it on a flat ground and tighten up all screws again.
6. Note : If one or some screws are fully tightened during assembly, chances are the others will not be aligned with holes. In addition, all the holes are designed to be relatively larger to provide more space for the adjustment of the screws.

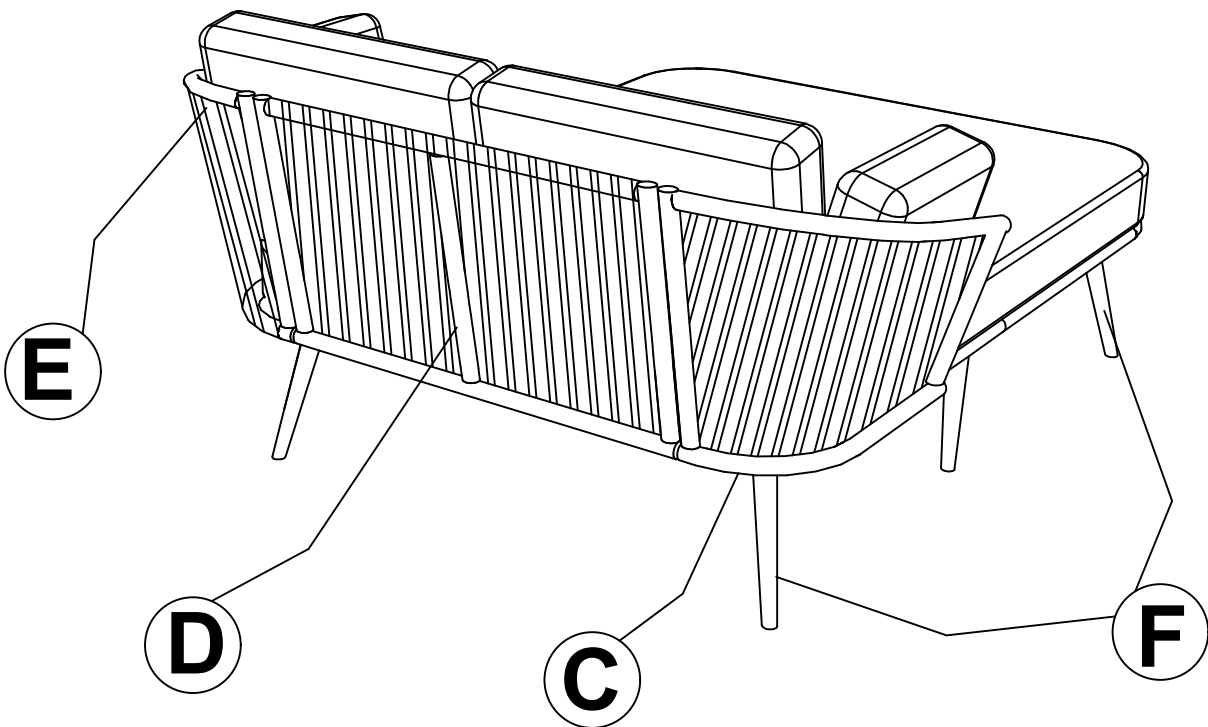
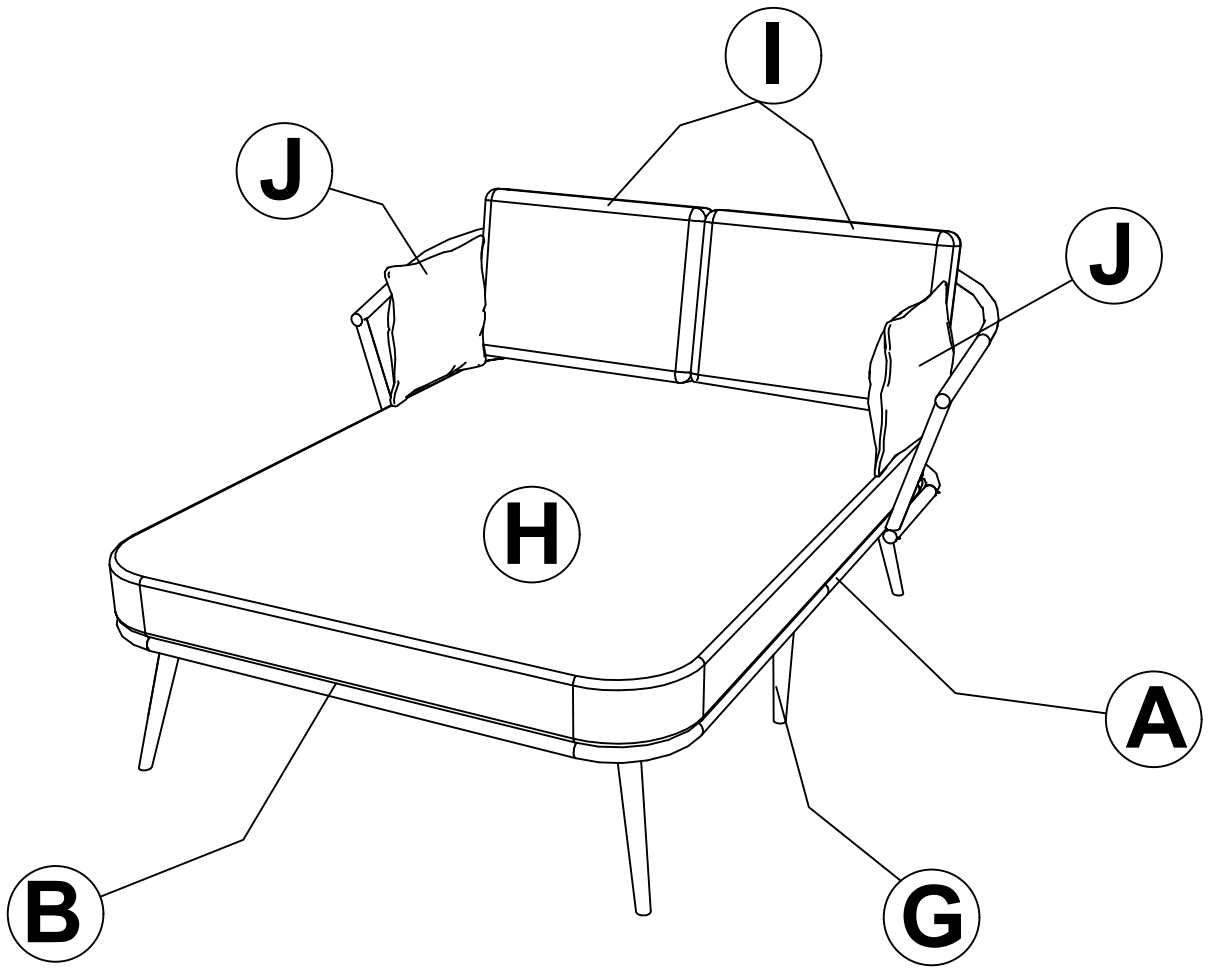

PART LIST

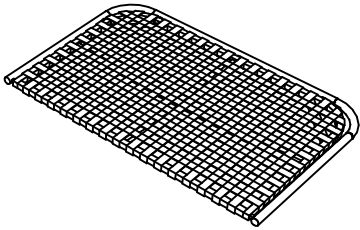

Ax1 Back bed frame

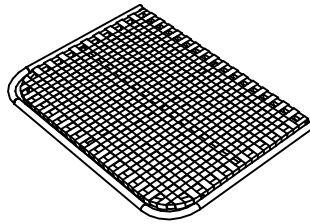

Bx1 Front bed frame

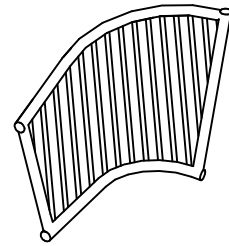

Cx1 Right frame

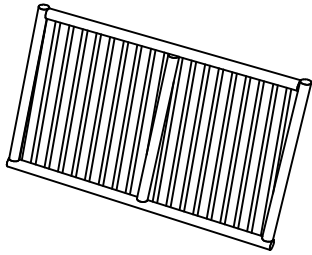

Dx1 Back frame

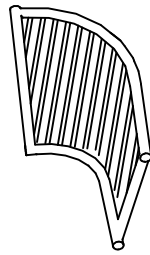

Ex1 Left frame

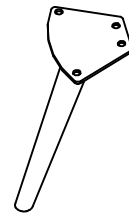

Fx4 Side leg

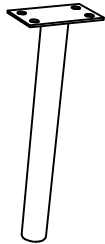

Gx3 Leg middle

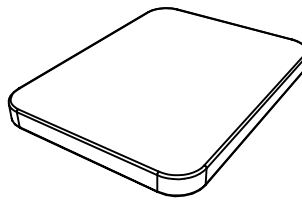

Hx1 Seat cushion

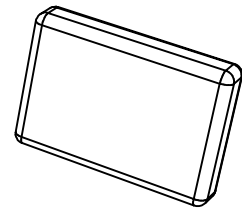

Ix2 Big pillow

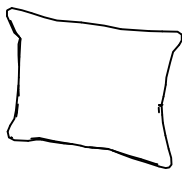

Jx2 Small pillow

HARDWARE LIST

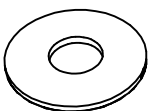

1- Washer: 43PCS
Extra : 2 pcs

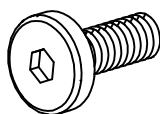

2- Bolt 6x15: 28PCS
Extra : 2 pcs

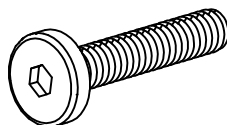

3- Bolt 6x40: 4PCS
Extra : 1 pcs

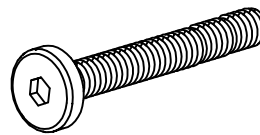

4- Bolt 6x50: 11PCS
Extra : 2 pcs

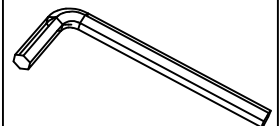

5- Allen key: 2PCS

CARTON CONTENT

WF317141

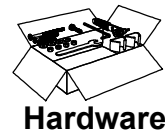
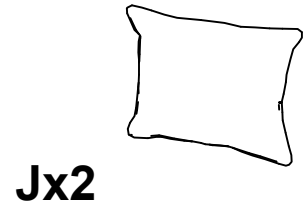
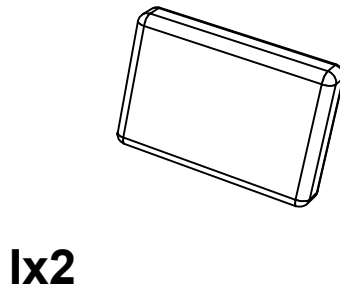
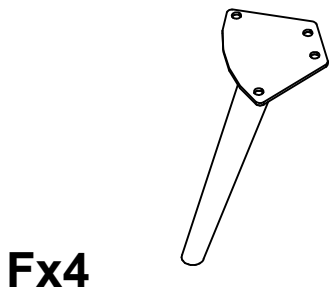
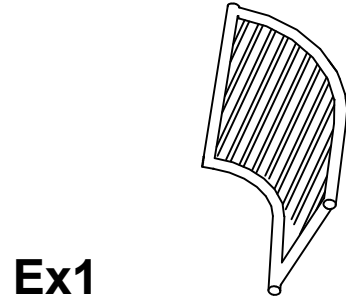
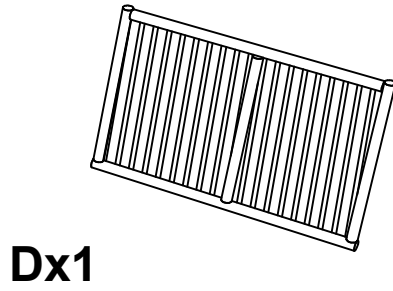
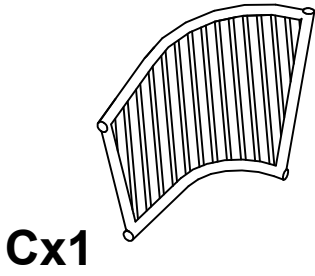

WF317142

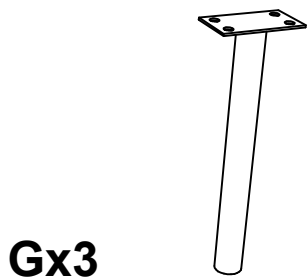
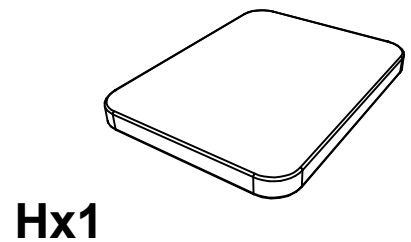
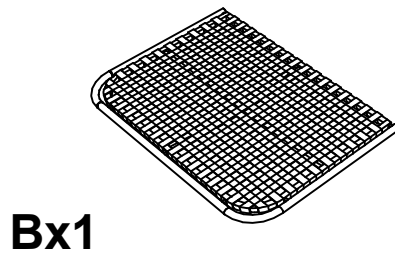
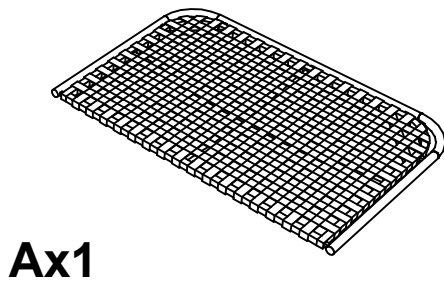

Step 1

Ax1 Bx1 ①x4 ③x4

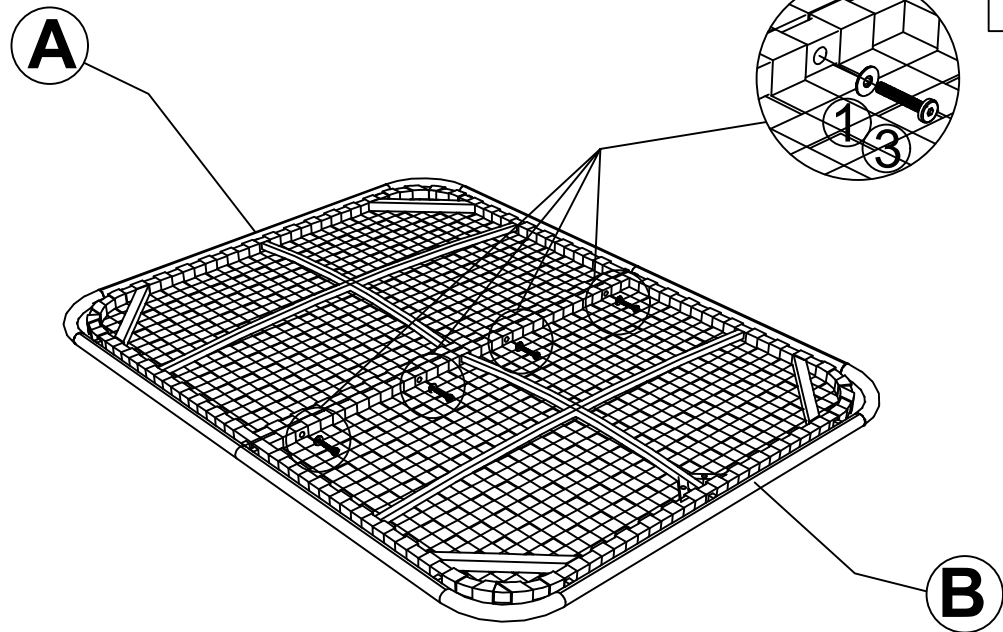

Connect The back bed frame (A) & front bed frame (B), tighten Bolt (3), Flat Washer (1) With Allen key (5)

Step 2

Fx4 ①x16 ②x16

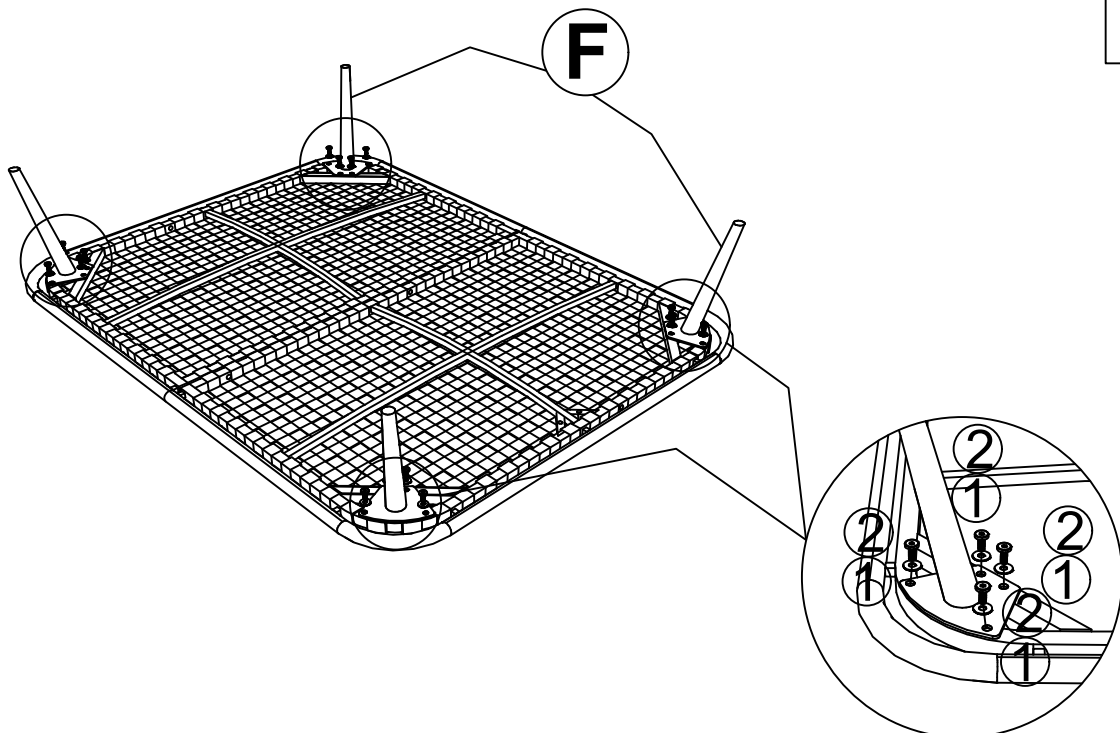

Connect The part from Step (1) & Side leg (F), tighten Bolt (2), Flat Washer (1) With Allen key (5)

Step 3 Gx3 ①x12 ②x12

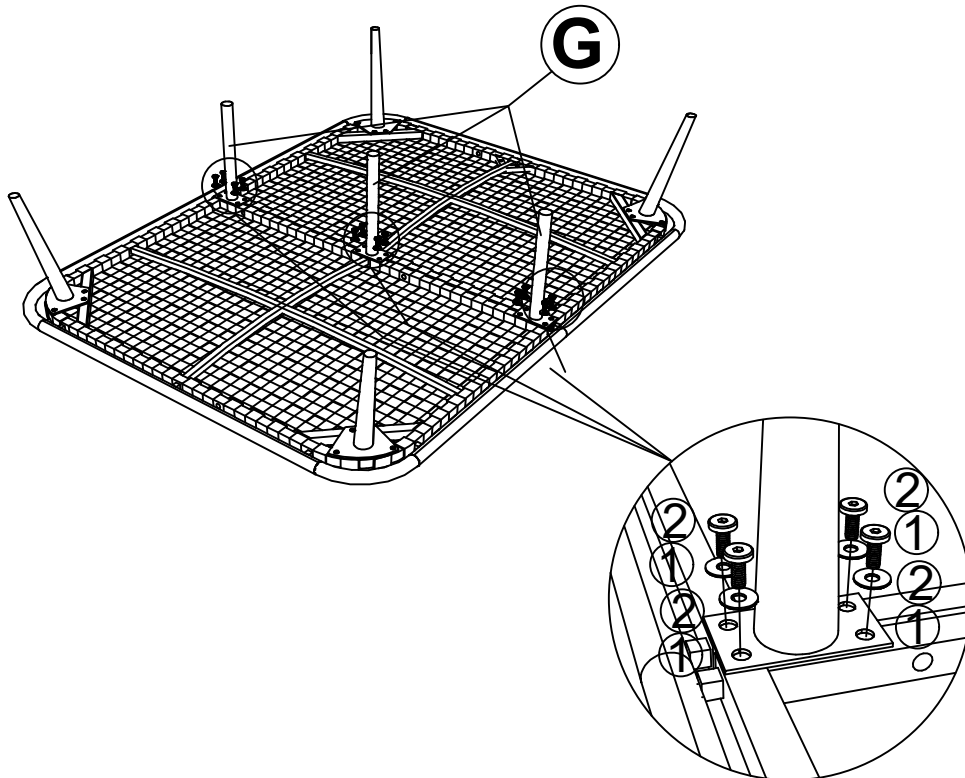

Connect The part from Step (2) & Middle leg (G), tighten Bolt (2), Flat Washer(1) With Allen key (5)

Step 4 Dx1 ①x3 ④x3

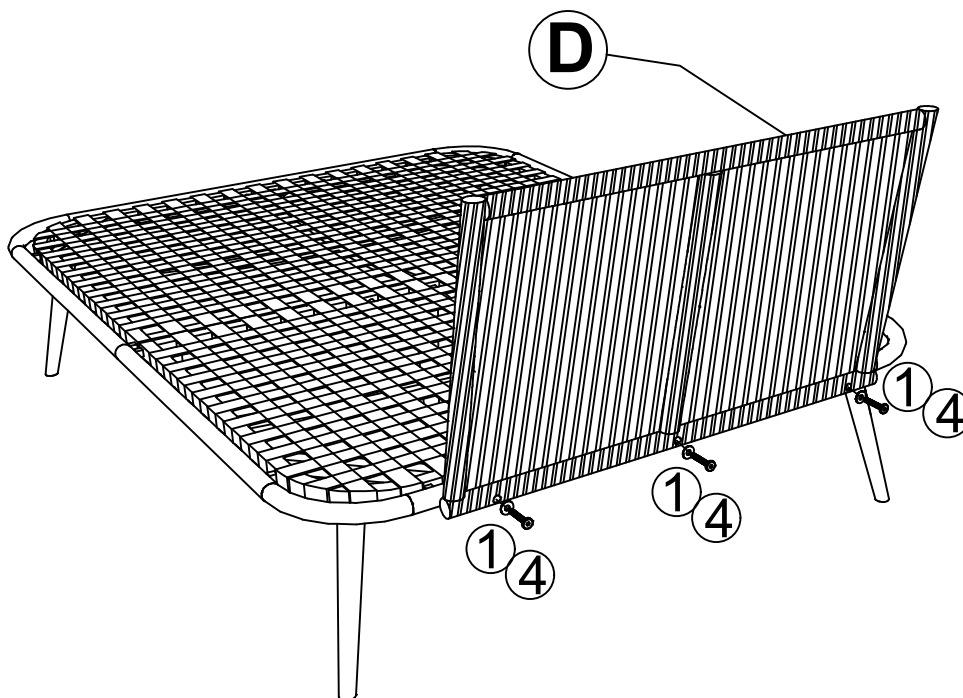

Connect The part from Step (3) & back frame (D), tighten Bolt (4), Flat Washer (1) With Allen key (5)

Step 5

Cx1 ①x4 ④x4

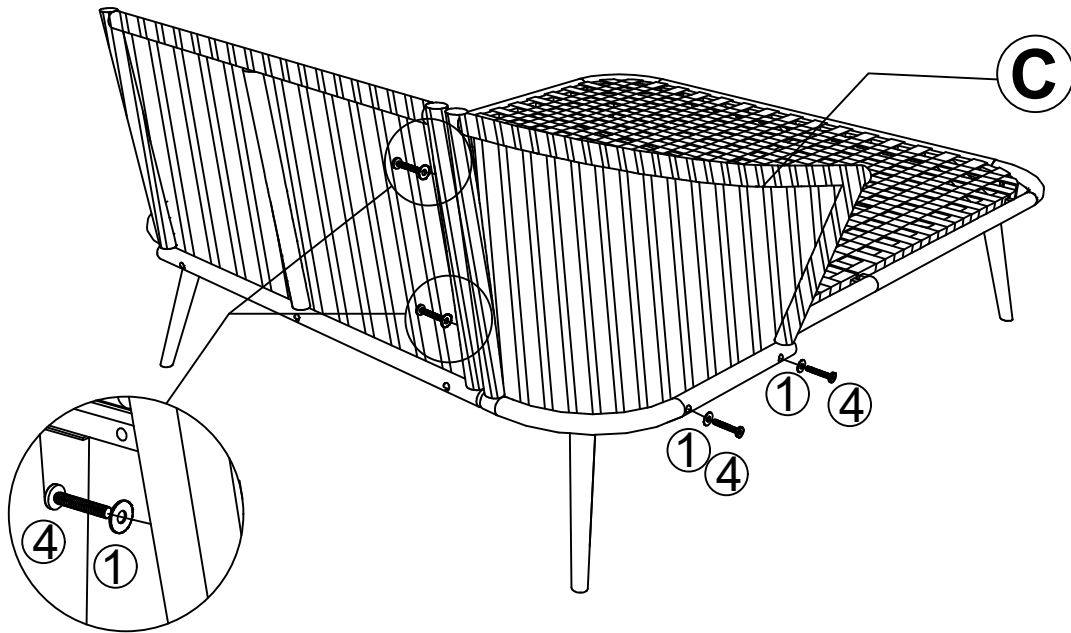

Connect The part from Step (4) & right frame (C), tighten Bolt (4), Flat Washer (1) With Allen key (5)

Step 6

Ex1 ①x4 ④x4

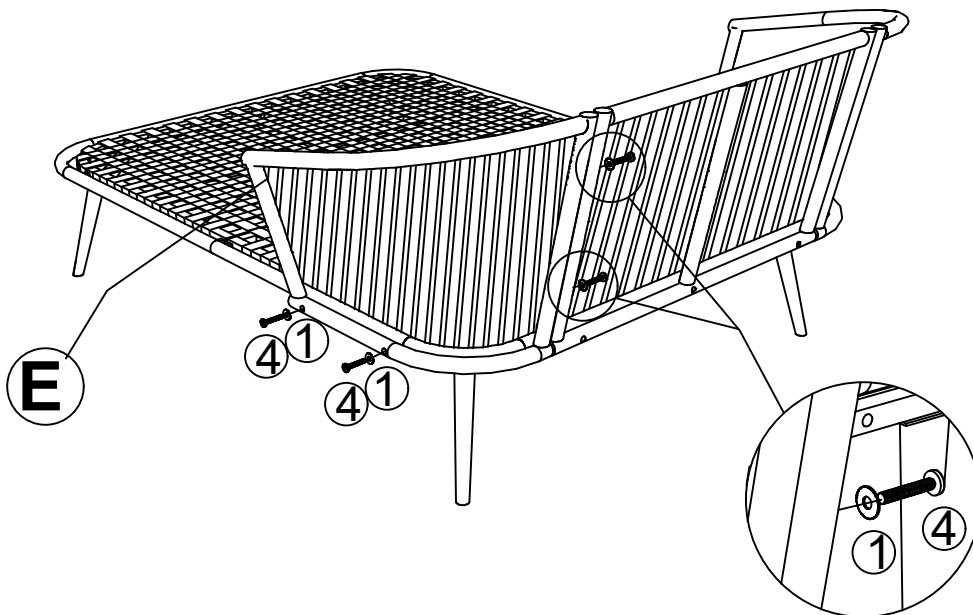

Connect The part from Step (5) & left frame (E), tighten Bolt (4), Flat Washer (1) With Allen key (5)

Step 7

Hx1 | Ix2 | Jx2

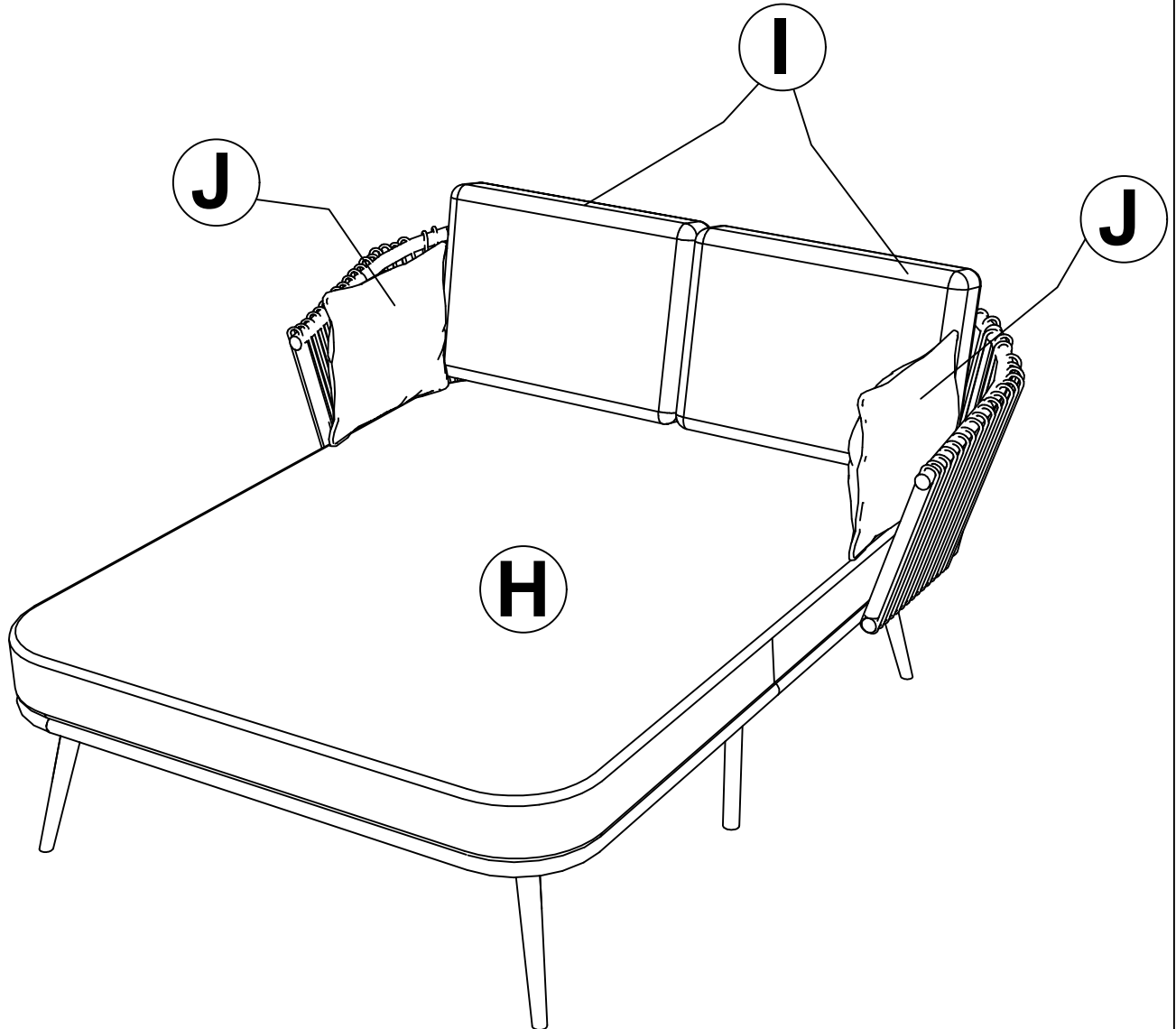

Put on Seat cushion (H), big pillow (I), Small pillow (J), to day bed to finish day bed

INSTALLATIONSANWEISUNG

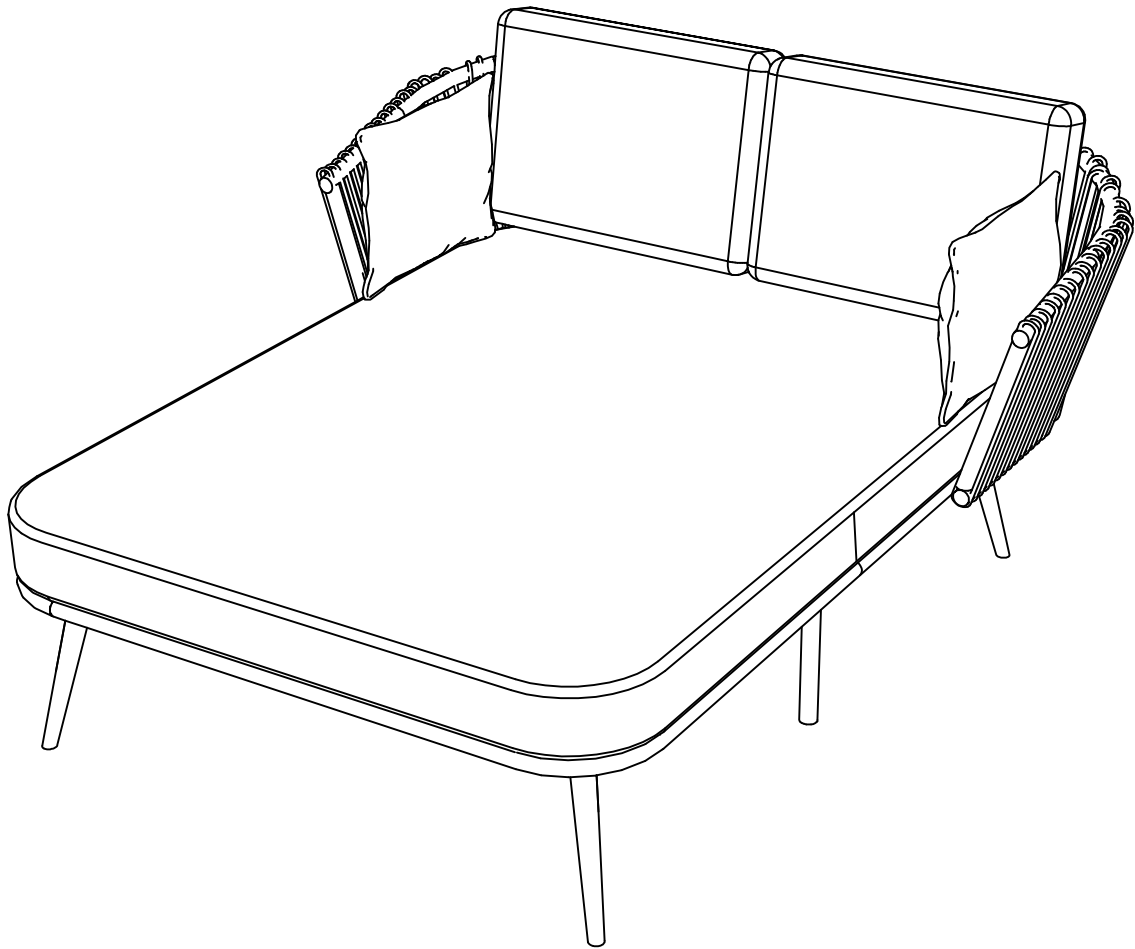

WF317141

WF317142

Beachten:

1. 50 % festziehen, bevor alle Schrauben befestigt werden. Anstelle einer elektrisch Bohrmaschine wird ein Inbusschlüssel empfohlen.
2. Stellen Sie den Gegenstand zum Ausrichten auf einen ebenen Untergrund und stellen sicher, dass er stabil bleibt.
3. Alle Schrauben mit Werkzeug nach und nach festziehe
4. Wenn die Schrauben bei der Montage nicht mit den Löchern übereinstimmen, lösen Sie bitte alle. Drehen Sie die anderen Schrauben auf 50 % und setzen Sie den Montagevorgang fort.
5. Sollte der Artikel nicht stabil stehen, lösen Sie bitte alle Schrauben, stellen Sie ihn auf einen ebenen Untergrund und ziehen Sie alle Schrauben wieder fest.
6. Hinweis: Wenn eine oder mehrere Schrauben während der Montage vollständig angezogen werden, besteht die Möglichkeit, dass die anderen nicht mit den Löchern ausgerichtet sind. Darüber hinaus sind alle Löcher relativ größer ausgelegt, um mehr Platz für die Justierung der Schrauben zu bieten.

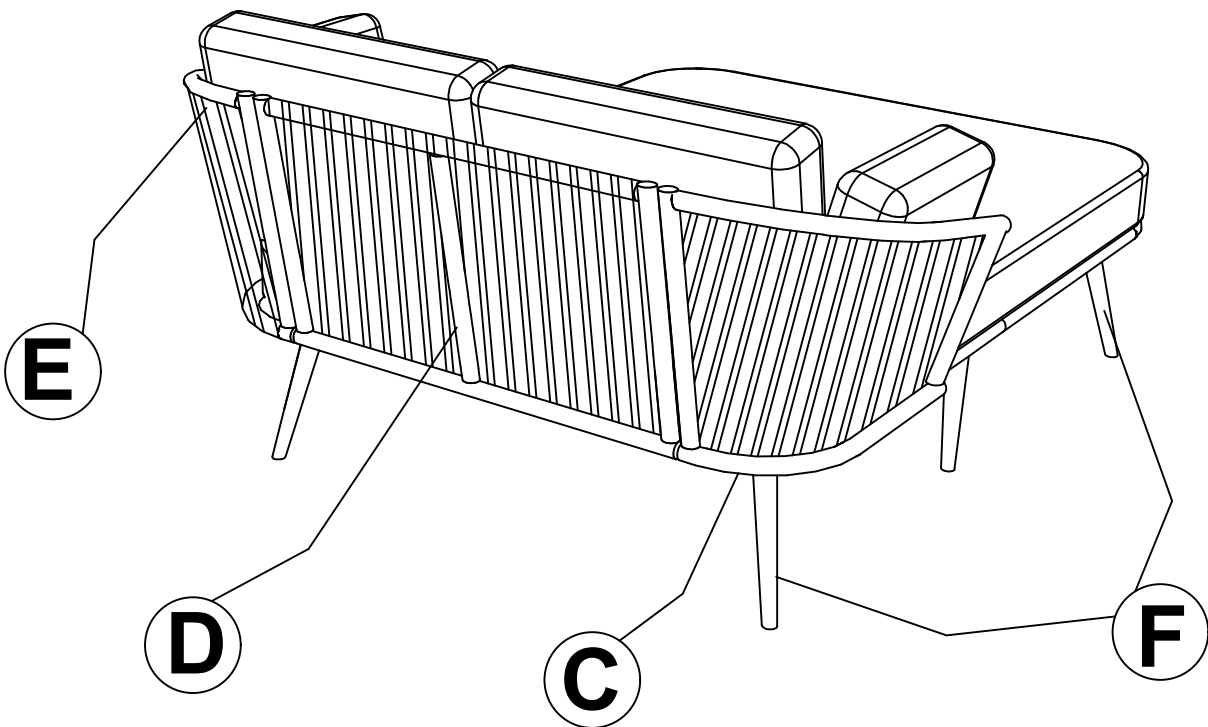
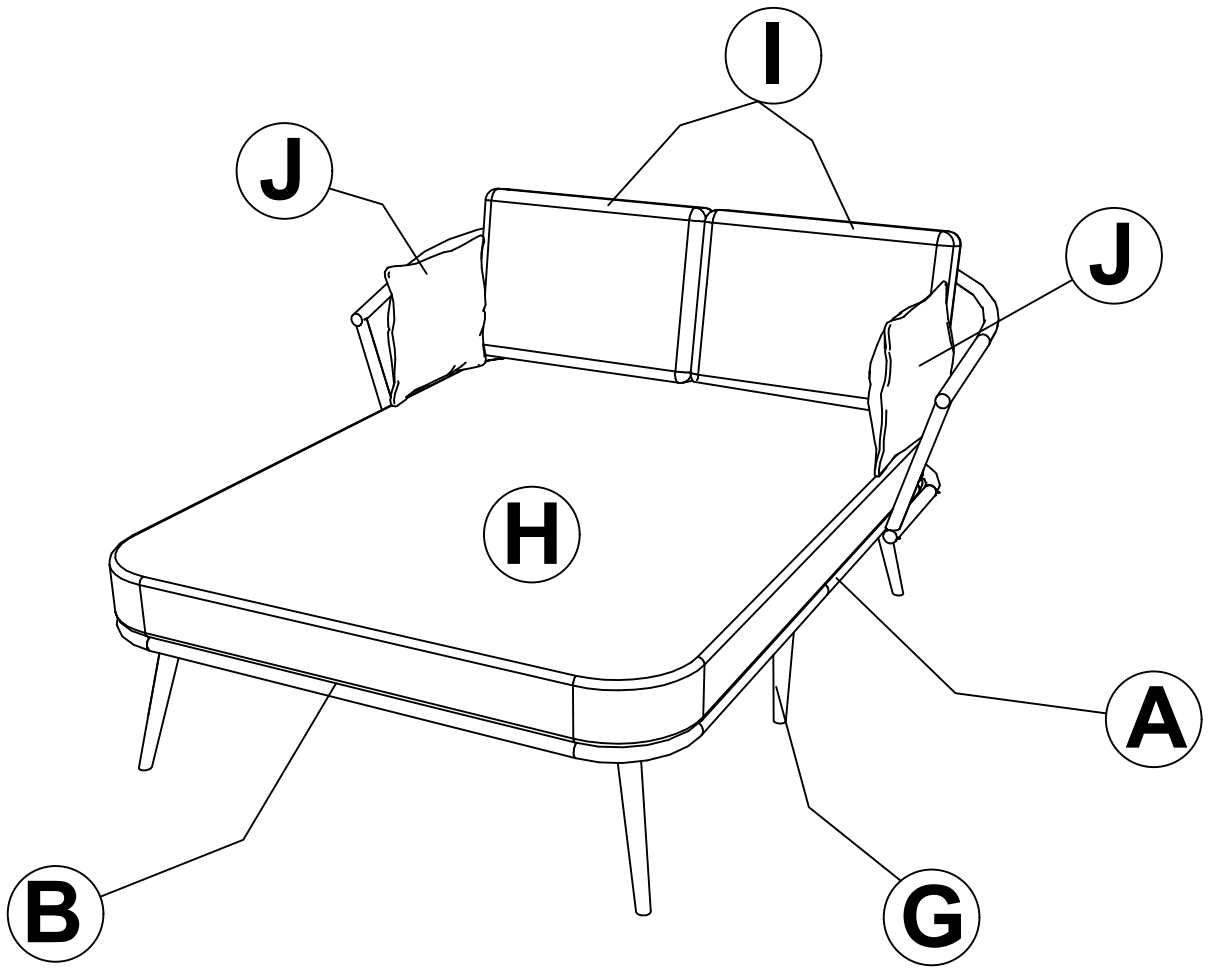

Teileliste

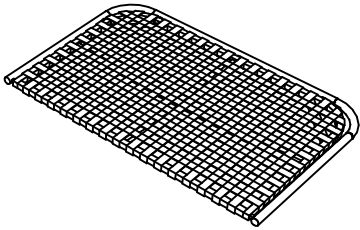

Ax1 Back bed frame

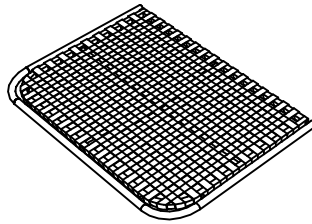

Bx1 Front bed frame

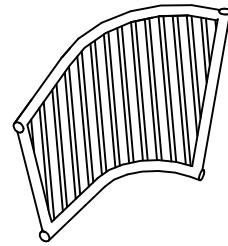

Cx1 Right frame

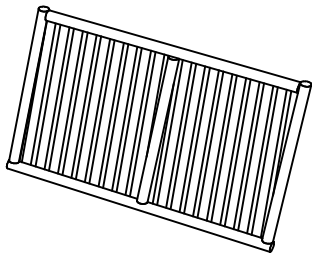

Dx1 Back frame

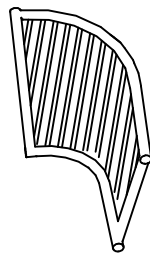

Ex1 Left frame

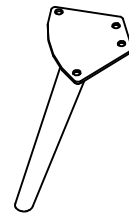

Fx4 Side leg

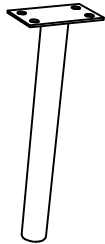

Gx3 Leg middle

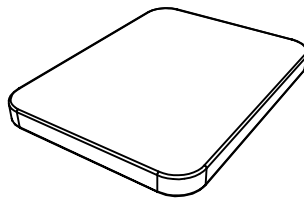

Hx1 Seat cushion

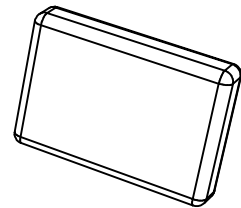

Ix2 Big pillow

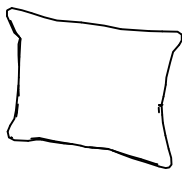

Jx2 Small pillow

Hardware Liste

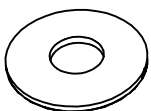

1- Washer: 43PCS
Extra : 2 pcs

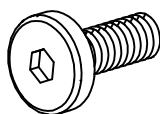

2- Bolt 6x15: 28PCS
Extra : 2 pcs

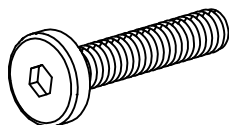

3- Bolt 6x40: 4PCS
Extra : 1 pcs

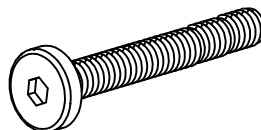

4- Bolt 6x50: 11PCS
Extra : 2 pcs

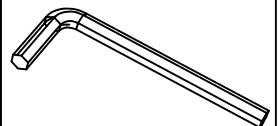

5- Allen key: 2PCS

INHALT DES KARTONS:

WF317141

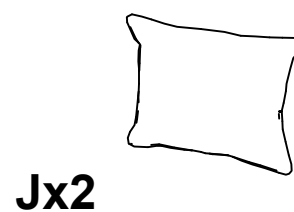
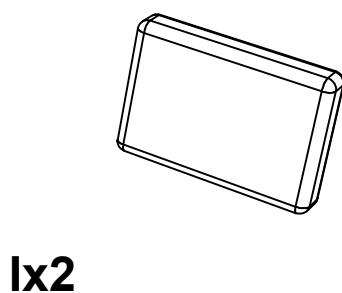
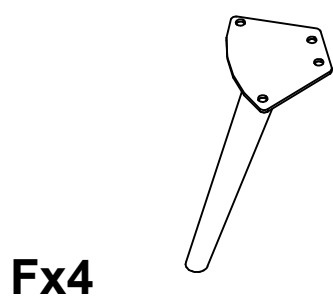
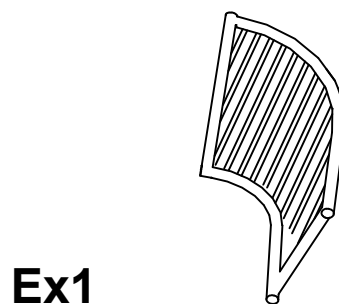
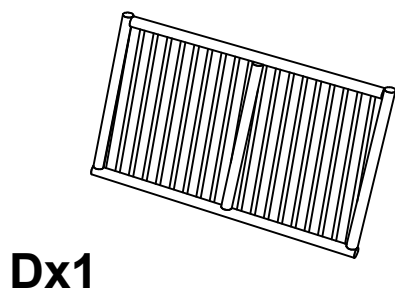
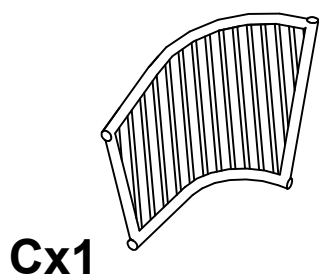

WF317142

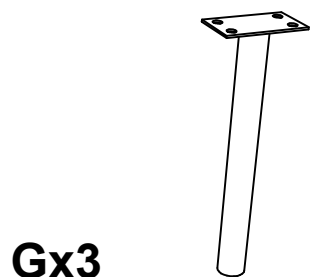
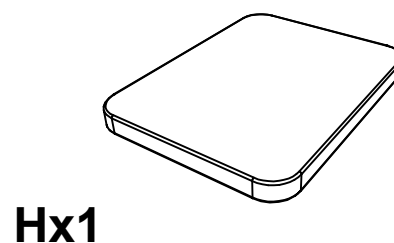
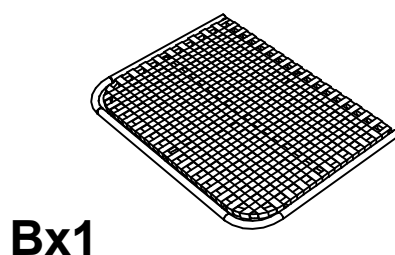
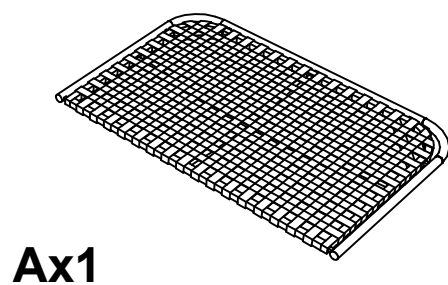

SCHRITT 1

Ax1 Bx1 ①x4 ③x4

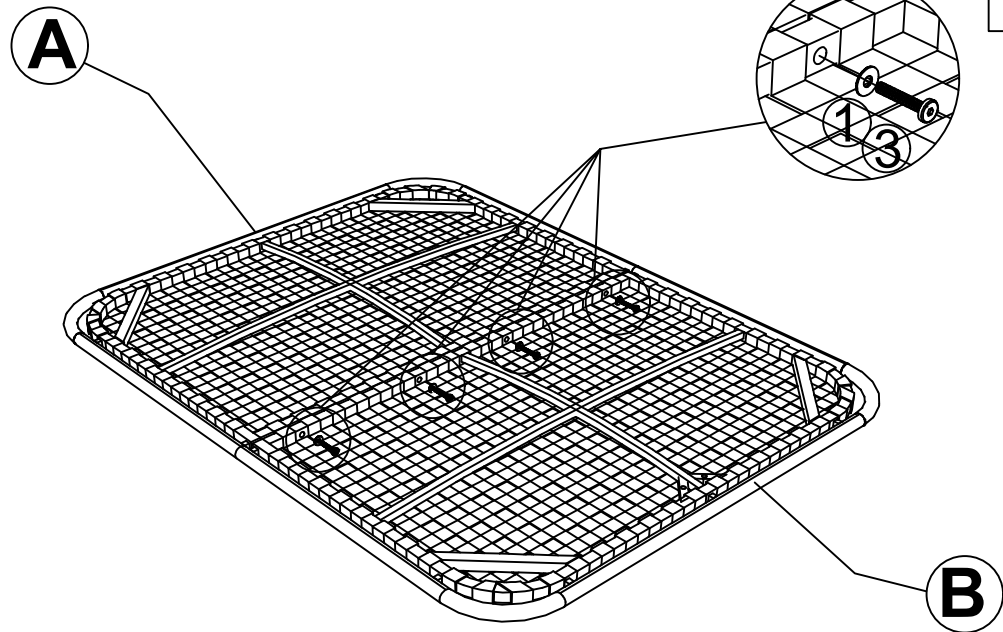

Verbinden Sie den hinteren Bettrahmen (A) und den vorderen Bettrahmen (B), ziehen Sie die Schraube (3) und die Unterlegscheibe (1) mit einem Inbusschlüssel (5) fest.

SCHRITT 2

Fx4 ①x16 ②x16

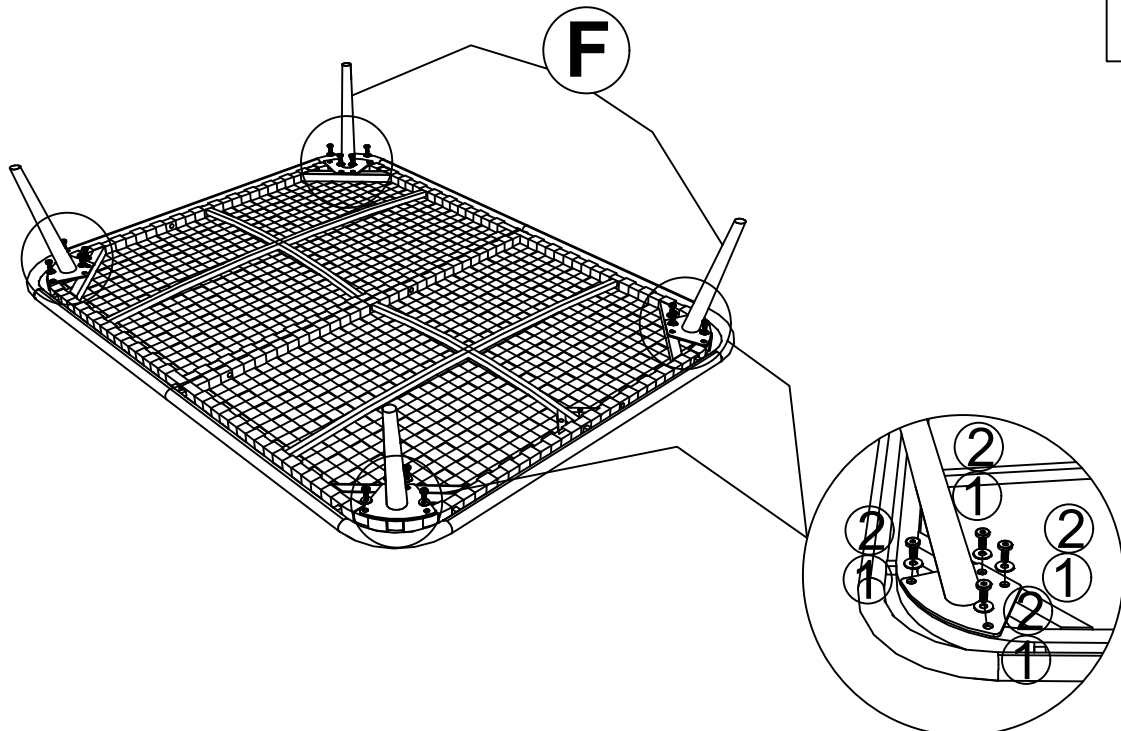

Verbinden Sie das Teil von Stufe (1) und Seitenbein (F), ziehen Sie Schraube (2), Unterlegscheibe (1) mit Inbusschlüssel (5) fest.

SCHRITT 3

Gx3 ①x12 ②x12

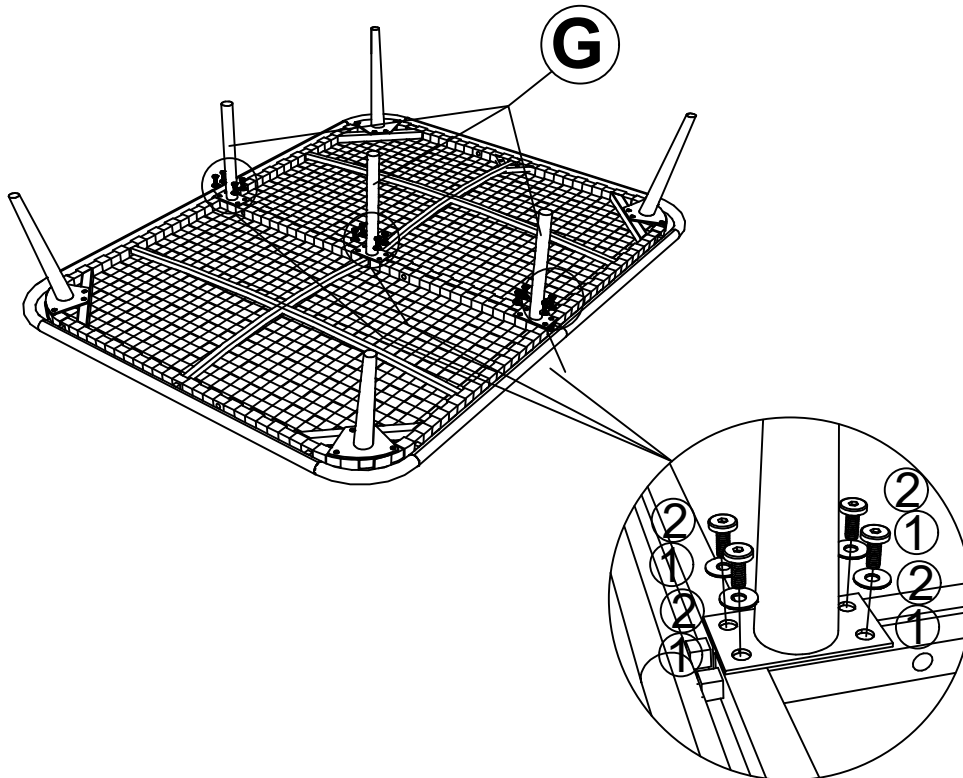

Verbinden Sie das Teil von Schritt (2) und mittlerem Bein (G), ziehen Sie Schraube (2), Unterlegscheibe (1) mit Inbusschlüssel (5) fest.

SCHRITT 4

Dx1 ①x3 ④x3

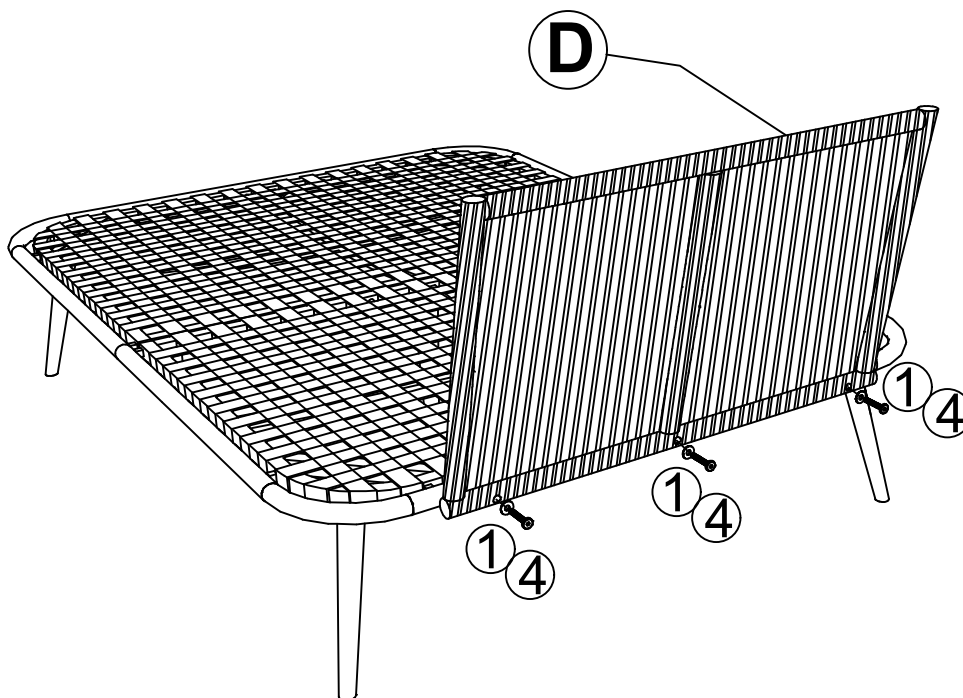

Verbinden Sie das Teil von Schritt (3) und dem hinteren Rahmen (D), ziehen Sie die Schraube (4) und die Unterlegscheibe (1) mit dem Inbusschlüssel (5) fest.

SCHRITT 5

Cx1 ①x4 ④x4

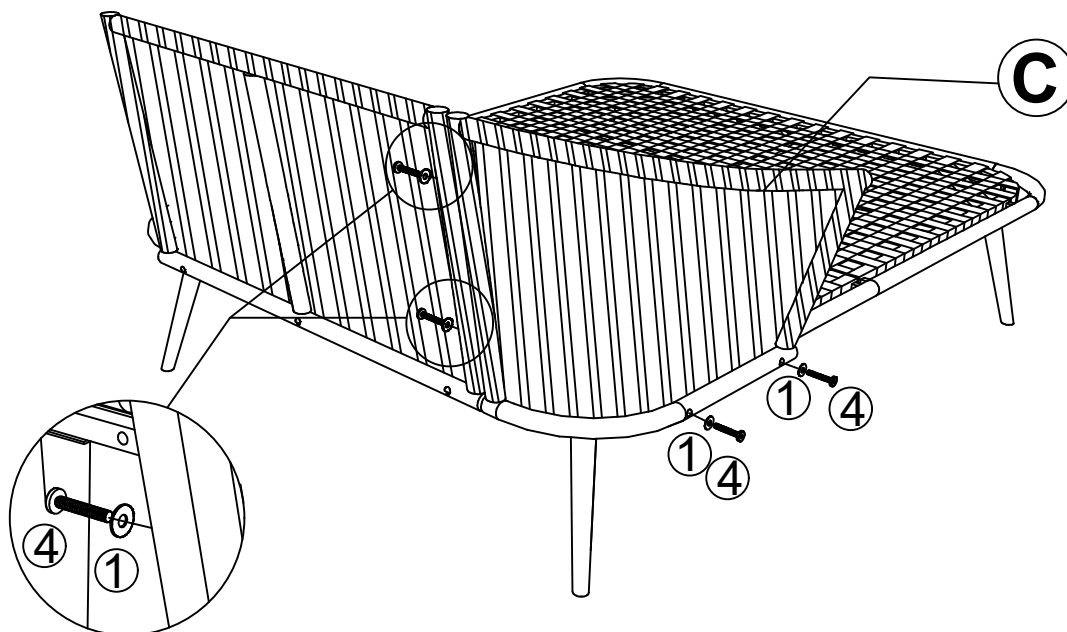
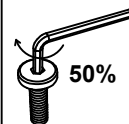

Verbinden Sie das Teil von Schritt (4) und dem rechten Rahmen (C), ziehen Sie die Schraube (4) und die Unterlegscheibe (1) mit dem Inbusschlüssel (5) fest.

SCHRITT 6

Ex1 ①x4 ④x4

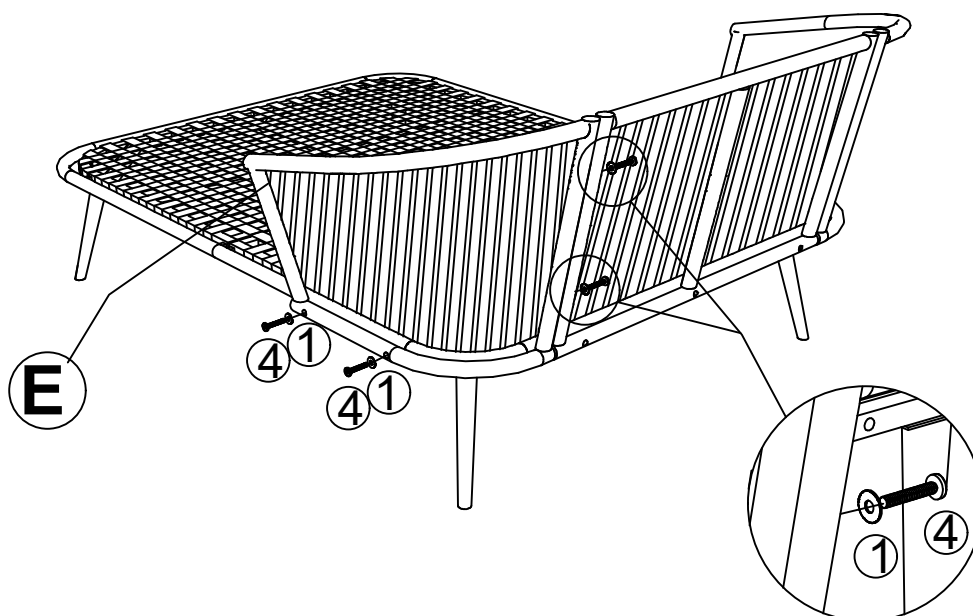
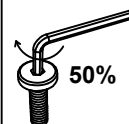

Verbinden Sie das Teil von Schritt (5) und dem linken Rahmen (E), ziehen Sie die Schraube (4) und die Unterlegscheibe (1) mit dem Inbusschlüssel (5) fest.

SCHRITT 7

Hx1 | Ix2 | Jx2

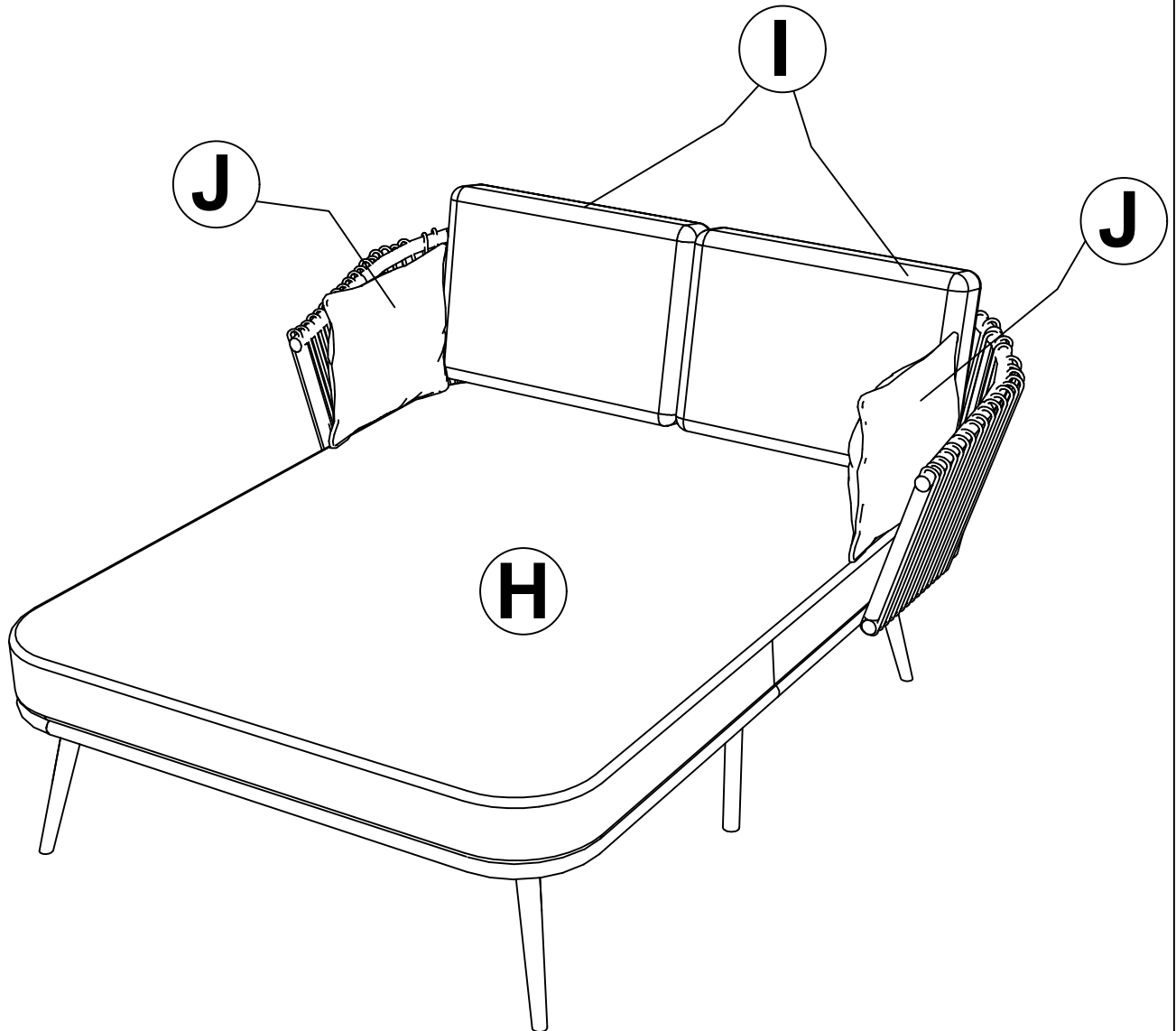

Legen Sie das Sitzkissen (H), das große Kissen (I) und das kleine Kissen (J) auf das Tagesbett, um das Tagesbett fertigzustellen